

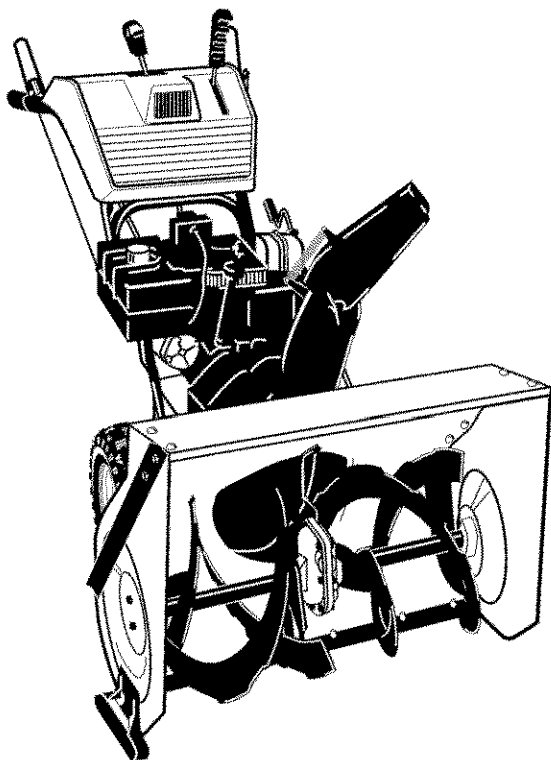

**12.5 Horsepower
33 Inch Dual Stage
120V. Electric Start
SNOW THROWER**

**MODEL NO.
536.881121**



Caution:

**Read and follow all Safety Rules
and Operating Instructions before
first use of this product.**

SEARS, ROEBUCK AND CO., Hoffman Estates, IL 60179 U.S.A.

F-001162J

SAFETY

ASSEMBLY

OPERATION

MAINTENANCE

PARTS LIST

ESPAÑOL

TABLE OF CONTENTS

| | | | |
|----------------------------|----|---------------------------|----|
| WARRANTY STATEMENT | 2 | STORAGE | 31 |
| SAFETY RULES | 2 | TROUBLE SHOOTING CHART .. | 32 |
| INTERNATIONAL SYMBOLS | 4 | REPAIR PARTS | 33 |
| ASSEMBLY | 7 | ENGINE REPAIR PARTS | 51 |
| OPERATION | 13 | SPANISH (ESPAÑOL) | 60 |
| MAINTENANCE | 20 | PARTS ORDERING/SERVICE .. | 96 |
| SERVICE AND ADJUSTMENT ... | 23 | | |

WARRANTY STATEMENT

LIMITED TWO-YEAR WARRANTY ON CRAFTSMAN SNOW THROWER

For two years from the date of purchase, when this Craftsman Snow thrower is maintained, lubricated, and tuned up according to the operating and maintenance instructions in the owner's manual, Sears will repair, free of charge, any defect in material or workmanship.

If this Craftsman Snow thrower is used for commercial or rental purposes, this warranty applies for only 90 days from the date of purchase.

This warranty does not cover the following:

- Items which become worn during normal use, such as spark plugs, drive belts and shear pins.
- Repair necessary because of operator abuse or negligence, including bent crankshafts and the failure to maintain the equipment according to the instructions contained in the owner's manual.

WARRANTY SERVICE IS AVAILABLE BY RETURNING THE CRAFTSMAN SNOW THROWER TO THE NEAREST Sears SERVICE CENTER/DEPARTMENT IN THE UNITED STATES. THIS WARRANTY APPLIES ONLY WHILE THIS PRODUCT IS IN USE IN THE UNITED STATES.

This warranty gives you specific legal rights, and you may also have other rights which may vary from state to state.

Sears, Roebuck and Co., D817WA, Hoffman Estates. IL 60179

SAFETY RULES



LOOK FOR THIS SYMBOL TO POINT OUT IMPORTANT SAFETY PRECAUTIONS. IT MEANS— ATTENTION!!! BECOME ALERT!!! YOUR SAFETY IS INVOLVED.



WARNING:



Engine Exhaust, some of its constituents, and certain vehicle components contain or emit chemicals known to the State of California to cause cancer and birth defects or other reproductive harm.

Battery posts, terminals and related accessories contain lead and lead compounds, chemicals known to the State of California to cause cancer and birth defects or other reproductive harm. **WASH HANDS AFTER HANDLING.**



WARNING: Always disconnect the spark plug wire and place it where it cannot make contact with spark plug to prevent accidental starting during: Preparation, Maintenance, or Storage of your snow thrower.

IMPORTANT: Safety standards require operator presence controls to minimize the risk of injury. Your snow thrower is equipped with such controls. Do not attempt to defeat the function of the operator presence control under any circumstances.

TRAINING

1. Read the operating and service instruction manual carefully. Be thoroughly familiar with the controls and the proper use of the equipment. Know how to stop the unit and disengage the controls quickly.
2. Never allow children to operate the equipment. Never allow adults to operate the equipment without proper instruction.
3. Keep the area of operation clear of all persons, particularly small children and pets.
4. Exercise caution to avoid slipping or falling especially when operating in reverse.

PREPARATION

1. Thoroughly inspect the area where the equipment is to be used and remove all doormats, sleds, boards, wires, and other foreign objects.
2. Disengage all clutches before starting the engine (motor).
3. Do not operate the equipment without wearing adequate winter outer garments. Wear footwear that will improve footing on slippery surfaces.
4. Handle fuel with care; it is highly flammable.
 - a. Use an approved fuel container.
 - b. Never remove fuel tank cap or add fuel to a running engine (motor) or hot engine (motor).
 - c. Fill fuel tank outdoors with extreme care. Never fill fuel tank indoors.
 - d. Replace fuel cap securely and wipe up spilled fuel.
 - e. Never store fuel or snow thrower with fuel in the tank inside of a building where fumes may reach an open flame or spark.
 - f. Check fuel supply before each use, allowing space for expansion as the heat of the engine (motor) and/or sun can cause fuel to expand.
5. For all units with electric starting motors use electric starting extension cords certified CSA/UL. Use only with a receptacle that has been installed in accordance with local inspection authorities.
6. Adjust the snow thrower height to clear gravel or crushed rock surface.
7. Never attempt to make any adjustments while the engine (motor) is running (except when specifically recommended by manufacturer).
8. Let engine (motor) and snow thrower adjust to outdoor temperatures before starting to clear snow.

9. Always wear safety glasses or eye shields during operation or while performing an adjustment or repair to protect eyes from foreign objects that may be thrown from the snow thrower.

OPERATION

1. Do not operate this machine if you are taking drugs or other medication which can cause drowsiness or affect your ability to operate this machine.
2. Do not use this machine if you are mentally or physically unable to operate this machine safely.
3. Do not put hands or feet near or under rotating parts. Keep clear of the discharge opening at all times.
4. Exercise extreme caution when operating on or crossing gravel drives, walks or roads. Stay alert for hidden hazards or traffic.
5. After striking a foreign object, stop the engine (motor), remove the wire from the spark plug, thoroughly inspect snow thrower for any damage, and repair the damage before restarting and operating the snow thrower.
6. If the unit should start to vibrate abnormally, stop the engine (motor) and check immediately for the cause. Vibration is generally a warning of trouble.
7. Stop the engine (motor) whenever you leave the operating position, before unclogging the auger/impeller housing or discharge chute and when making any repairs, adjustments, or inspections.
8. When cleaning, repairing, or inspecting, make certain the auger/impeller and all moving parts have stopped and all controls are disengaged. Disconnect the spark plug wire and keep the wire away from the spark plug to prevent accidental starting.
9. Take all possible precautions when leaving the snow thrower unattended. Disengage the auger/ impeller, stop engine (motor), and remove key.
10. Do not run the engine (motor) indoors, except when starting the engine (motor) and for transporting the snow thrower in or out of the building. Open the outside doors; exhaust fumes are dangerous (containing CARBON MONOXIDE, an ODORLESS and DEADLY GAS).
11. Do not clear snow across the face of slopes. Exercise extreme caution when changing direction on slopes. Do not attempt to clear steep slopes.
12. Never operate the snow thrower without proper guards, plates or other safety protective devices in place.

13. Never operate the snow thrower near enclosures, automobiles, window wells, drop-offs, and the like without proper adjustment of the snow discharge angle. Keep children and pets away.
14. Do not overload the machine capacity by attempting to clear snow at too fast a rate.
15. Never operate the machine at high transport speeds on slippery surfaces. Look behind and use care when backing up.
16. Never direct discharge at bystanders or allow anyone in front of the unit.
17. Disengage power to the collector/impeller when snow thrower is transported or not in use.
18. Use only attachments and accessories approved by the manufacturer of the snow thrower (such as tire chains, electric start kits, ect.).
19. Never operate the snow thrower without good visibility or light. Always be sure of your footing and keep a firm hold on the handles. Walk; never run.
20. Do not over-reach. Keep proper footing and balance at all times.
21. Do not attempt to use snow thrower on a roof.

MAINTENANCE AND STORAGE

1. Check shear bolts and other bolts at frequent intervals for proper tightness to be sure the equipment is in safe working condition.
2. Never store the snow thrower with fuel in the tank inside a building where ignition sources are present such as hot water and space heaters, clothes dryers, and the like. Allow the engine (motor) to cool before storing in any enclosure.
3. Always refer to operator's guide instructions for important details if the snow thrower is to be stored for an extended period.
4. Maintain or replace safety and instruction labels, as necessary.
5. Run the snow thrower a few minutes after throwing snow to prevent freeze-up of the auger/impeller.



WARNING: This snow thrower is for use on sidewalks, driveways and other ground level surfaces.

Caution should be exercised while using on steep sloping surfaces. **DO NOT USE SNOW THROWER ON SURFACES ABOVE GROUND LEVEL** such as roofs of residences, garages, porches or other such structures or buildings.

SYMBOLS

IMPORTANT: Many of the following symbols are located on your unit or on literature supplied with the product. Before you operate the unit, learn and understand the purpose for each symbol.

Control And Operating Symbols



Slow



Fast



Electric Start



Engine Start



Engine Run



Engine Off



Engine Stop



On



Choke Off



Choke On



Neutral



Throttle

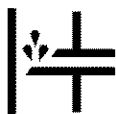

Primer Button

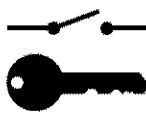

Ignition Key



Ignition Off



Ignition On



Drive Clutch



Forward



Reverse



Auger Clutch



Auger Collector



Engage

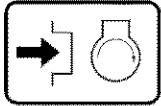

Push To Engage
Electric Starter



Fuel



Oil



Fuel Oil Mixture



Discharge DOWN



Discharge UP



Discharge LEFT



Discharge RIGHT



Weight Transfer
Lift Handle To
Engage



Weight Transfer
Depress Pedal
To Disengage



Transmission

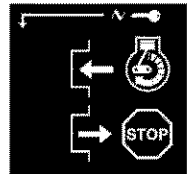

Ignition Key
Insert To Run,
Pull Out To Stop.

Safety Warning Symbols



DANGER
Thrown Objects.
Keep Bystanders Away.

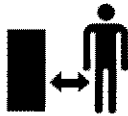

DANGER
Thrown Objects.
Keep Bystanders Away.



WARNING



IMPORTANT
Read Owner's Manual
Before Operating
This Machine.



DANGER
Avoid Injury From
Rotating Auger. Keep
Hands, Feet And
Clothing Away.



DANGER
Stop The Engine
Before Unclogging
Discharge Chute!



WARNING
Hot Surface



STOP

ASSEMBLY

Contents of Parts Bag (actual size)

- 1 – Owner's Manual (not shown)
- 1 – Packet of Fuel Stabilizer (not shown)
- 1 – Warranty Card (not shown)
- 2 – Parts bags (not shown)

*Non-Assembly Parts, found in toolbox located on belt cover

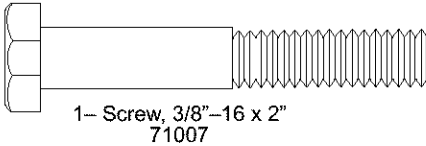

1– Screw, 3/8"–16 x 2"
71007

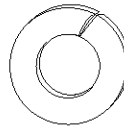

1–Split Lockwasher
71062

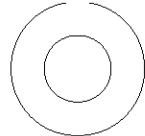

2–Flatwasher 3/8"
71072

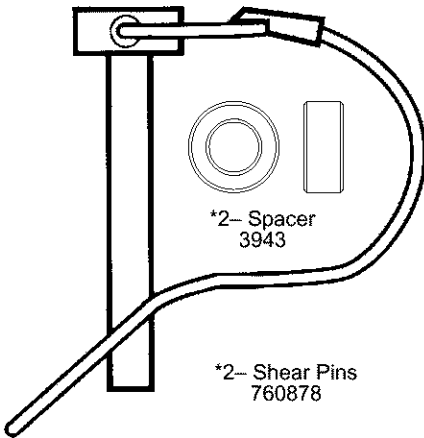

*2– Spacer
3943

*2– Shear Pins
760878

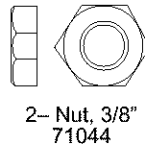

2– Nut, 3/8"
71044



1 – Remote Chute Knob
(not actual size)

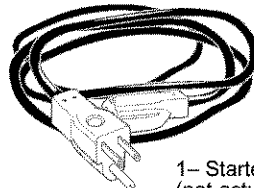

1– Starter Cord
(not actual size)



1 – Shift Lever Knob
(not actual size)

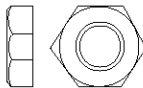

1 – Hex Jam Nut 1/4"
71034

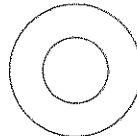

1 – Flatwasher 3/8"
71071



1 – Cotter Pin
71081

Parts packed separately in carton (not shown full size)



2– Ignition Keys
(Attached to engine in plastic bag)

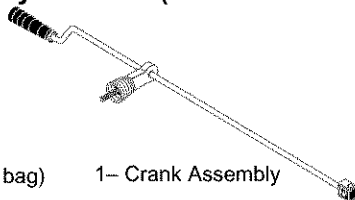

1– Crank Assembly

ASSEMBLY

Read and follow the assembly and adjustment instructions for your snow thrower. All fasteners are in the parts bag. Do not discard any parts or material until the unit is assembled.



WARNING: Before doing any assembly or maintenance to the snow thrower, remove the wire from the spark plug.



WARNING: Always wear safety glasses or eye shields while assembling snow thrower.

NOTE: In this instruction book, left and right describe the location of a part from the operator's position behind the unit.

Tools Required

- 1 Knife
- 1 Pliers
- 1 1/2 inch open end wrenches
- 1 9/16 inch open end wrenches
- 1 3/4 inch open end wrenches
- 1 3/8 inch open end wrenches
- 1 Measuring tape or ruler
- 1 Screwdriver

Figure 1 shows the snow thrower in the shipping position.

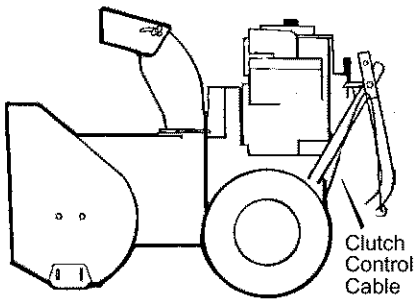

Figure 1

Figure 2 shows the snow thrower completely assembled.

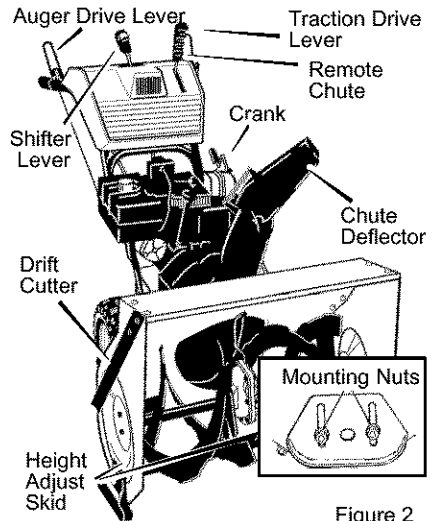

Figure 2

How To Remove The Snow Thrower From The Carton

1. Locate the two tear tabs at the bottom of the carton.
2. Pull the tear tape no more than twelve inches (30.48cm.) at a time. Re-grasp tape next to the carton

and pull again. Repeat until all the tape is torn off.

3. After the tape has been completely removed from the carton, remove the carton from the base. Cut all four corners and fold the sides toward the center for easy disposal.

ASSEMBLY

4. Remove the plastic bag that covers the unit.
5. Locate and remove the fuel stabilizer and the parts bag.

NOTE: Put fuel stabilizer in a safe place until needed for storage.

6. Cut and discard the plastic ties that secure the crank assembly rod and if equipped the speed select rod.
7. For shipping purposes, the **height adjust skids** are attached to the pallet. Remove the **screw** that secures each **height adjust skid** to the pallet. See Figure 3.

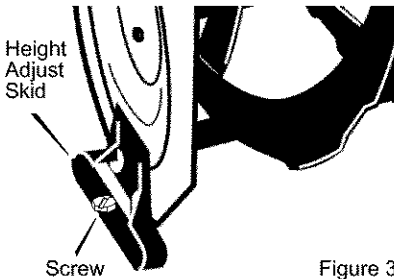

Figure 3

8. Roll the snow blower off the carton by pulling on the lower handle.

CAUTION: DO NOT back over cables.

9. Remove the packing material from the handle assembly.
10. Cut ties securing the clutch control cables to the lower handle.

NOTE: If the cables have become disconnected from the clutch levers, reinstall the cables as shown in Figure 4.

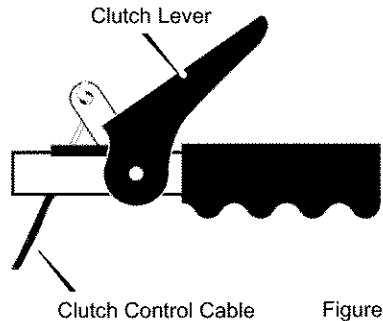

Figure 4

How To Assemble The Handle And Crank Assembly

1. Loosen, but do not remove, the **fasteners** in the upper holes of the lower handle. See Figure 5.

2. Install the **screw, flatwasher, lockwasher, and hex nut** into the bottom hole on the right side of the handles. **DO NOT** tighten until all fasteners are in place.

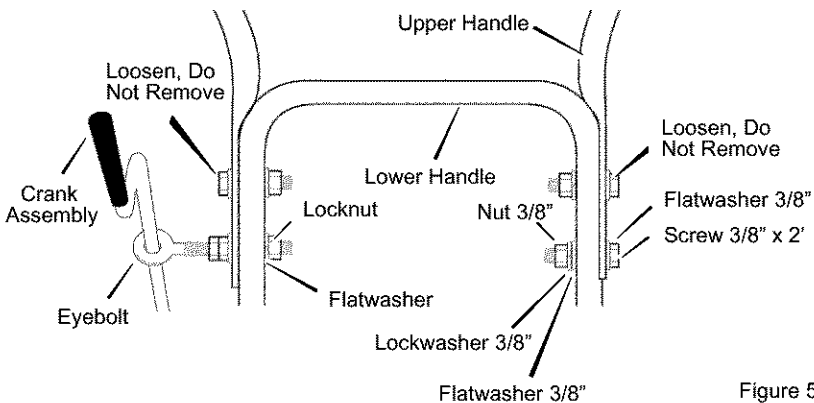

Figure 5

ASSEMBLY

3. Locate the **crank assembly** removed earlier. Remove the **locknut** and **flatwasher** from the **eye bolt assembly**.
4. Install the **eye bolt** through the lower hole on the left side of the handles.
5. Install the **flatwasher** and the **locknut** loosely on the **eye bolt**.
6. Carefully remove **cotter pin**, **clevis pin**, **universal joint pin**, and **universal joint** from the **crank rod assembly**. See Figure 6.
7. Mount the **universal joint** into the end of the **worm gear**. Make sure the large holes are aligned.
8. Insert **universal joint pin**. Make sure opening in **universal joint pin** is aligned with small opening in **universal joint**.
9. Mount the yoke end of **crank rod** around the **universal joint**. Fasten

with **clevis pin** and **cotter pin**. Spread ends of **cotter pin** to lock in place.

10. Tighten the locknut on the **eye bolt**. See Figure 5. Make sure **eye bolt** is properly aligned and the **crank** can freely rotate.
11. Tighten all handle fasteners.

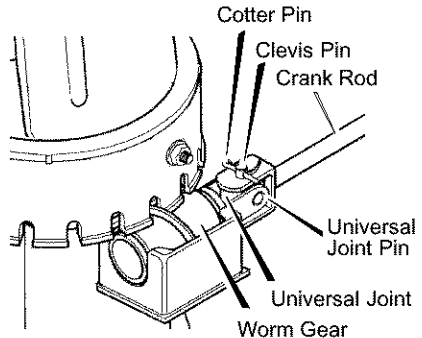

Figure 6

How To Install The Knobs

Remote Chute Knob

1. Install the **nut** onto the **lever**. See Figure 7.

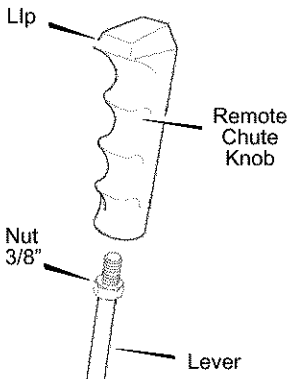

Figure 7

2. Assemble the **remote chute knob** onto the **lever** until snug against the **nut**.
3. Make sure **lip** on the **remote chute knob** is pointed toward the engine.

4. Tighten the **nut** against the bottom of the **remote chute knob**.

Speed Select Knob

1. Install the **nut** onto the **lever**. See Figure 8.
2. Assemble the **speed select knob** onto the **lever** until snug against the **nut**.
3. Tighten the **nut** against the bottom of the **speed select knob**.

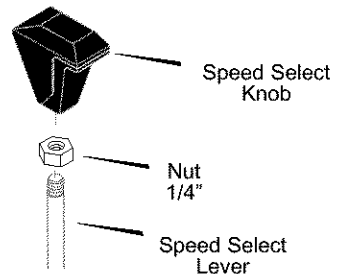

Figure 8

ASSEMBLY

How To Install The Speed Control Rod

1. Put the **speed select lever** into the sixth gear position.
2. Attach the **speed control rod** (end with 90° bend) to the **speed select bracket** with **washer** and **cotter pin**. See Figure 9.
3. Put the **speed select lever** into the first gear position.
4. Attach the **ball joint**, located on the bottom end of the **speed control rod**, to the **shift yoke assembly**. See Figure 10. The **fasteners** are attached to the **ball joint** at the factory.

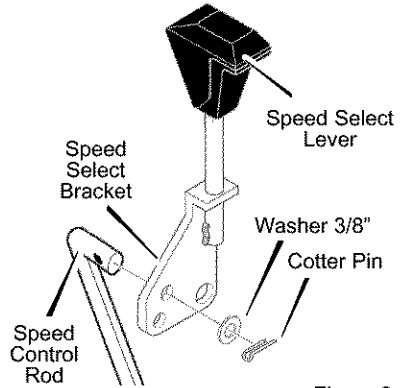

Figure 9

The length of the **ball joint** and **speed control rod** have been pre-adjusted at the factory. If an adjustment is required, loosen the **nut**. Remove the **fasteners** to disconnect the **ball joint** from the **shift yoke assembly**. To lengthen or shorten the **speed control rod**, turn the **adapter** to obtain the correct length.

5. Make sure the **speed select lever** functions correctly. Move the **speed select lever** through all speeds.

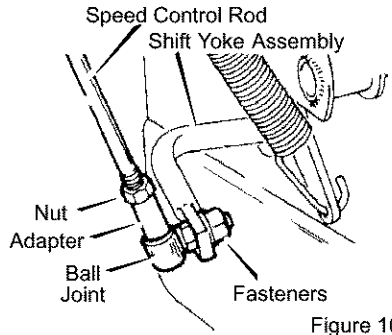

Figure 10

How To Assemble The Chute Deflector

1. Remove the **carriage bolt**. See Figure 11.
2. Raise the **chute deflector** into **operating position**.
3. Fasten **chute deflector** to **flange** with **carriage bolt**. Make sure to

install with head of **carriage bolt** on the inside of the **flange**.

4. Fasten with **washer** and **locknut**.
5. Tighten **locknut** securely.

NOTE: Make sure all carriage bolts in flange are tight. DO NOT OVERTIGHTEN.

6. Cut **tie strap** on **chute deflector**.

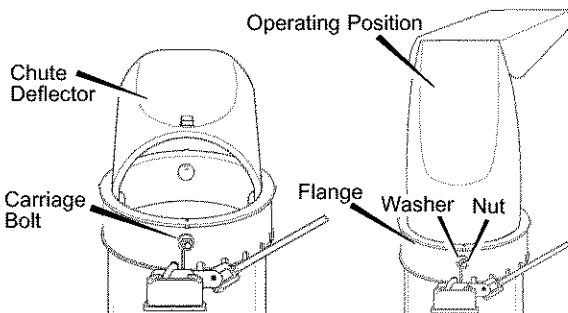
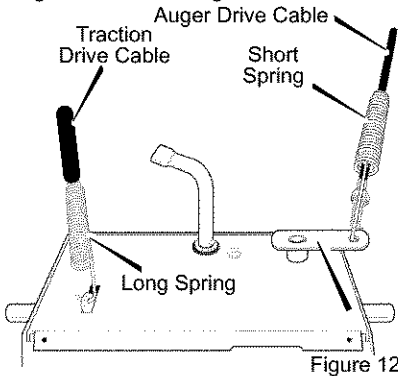

Figure 11

ASSEMBLY

Check The Cables

1. Check the **traction drive cable** and the **auger drive cable**. If the bottom of the cables have become disconnected, reinstall the cable springs. Make sure the **long spring** is attached to the traction drive and the **short spring** is attached to the auger drive. See Figure 12.



2. If the top of the **cables** have become disconnected from the **drive levers**, attach the **cables** to the **"Z" fitting**. See Figure 13.

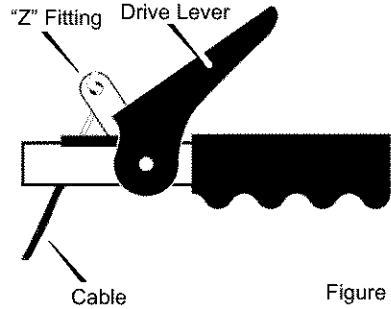

How To Set The Skid Height

The snow thrower is equipped with **height adjustable skids** mounted on the outside of the auger housing. See Figure 14. To adjust the height of the skids, see "How To Adjust The Height Of The Skids" in the Maintenance section.

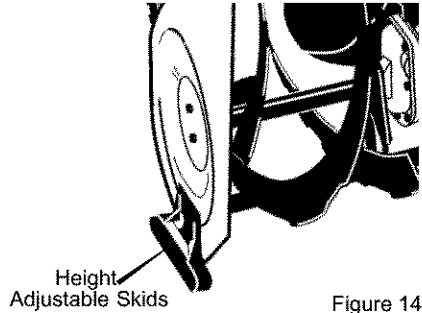

How To Set The Length Of The Cables

The cables were adjusted at the factory and no adjustments should be necessary. However, after the handles are put in the operating position, the cables can be too tight or too loose. If an adjustment is necessary, see "How To Check And Adjust The Cables" in the Service And Adjustment section.

ASSEMBLY

How To Set The Drift Cutters

Drift cutters are used to cut a path through snow deeper than the auger housing.

1. Loosen the **wingnuts** that secure the **drift cutters** to the auger housing. See Figure 15.
2. Raise the **drift cutters** to the desired height.
3. Tighten the **wingnuts**.

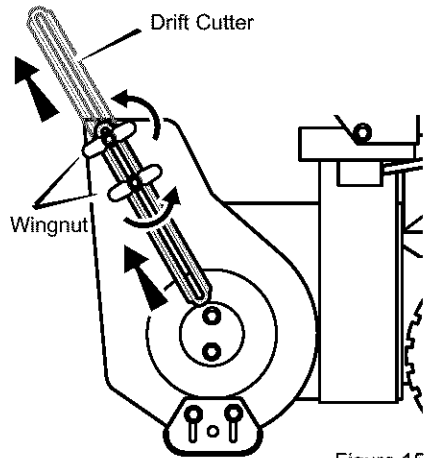

Figure 15

✓ CHECKLIST

Before you operate your new snow thrower, to ensure that you receive the best performance and satisfaction from this quality product, please review the following checklist:

- ✓ All assembly instructions have been completed.
- ✓ The discharge chute rotates freely.
- ✓ No remaining loose parts in carton.

While learning how to use your snow thrower, pay extra attention to the following important items:

- ✓ Engine oil is at proper level.
- ✓ Make sure gas tank is filled properly with clean, fresh, unleaded gasoline.
- ✓ Become familiar with all controls—their location and function. Operate controls before starting engine.

OPERATION

KNOW YOUR SNOW THROWER

READ THIS OWNER'S MANUAL AND SAFETY RULES BEFORE OPERATING YOUR SNOW THROWER. Compare the illustrations with your SNOW THROWER to familiarize yourself with the location of various controls and adjustments. Save this manual for future reference.

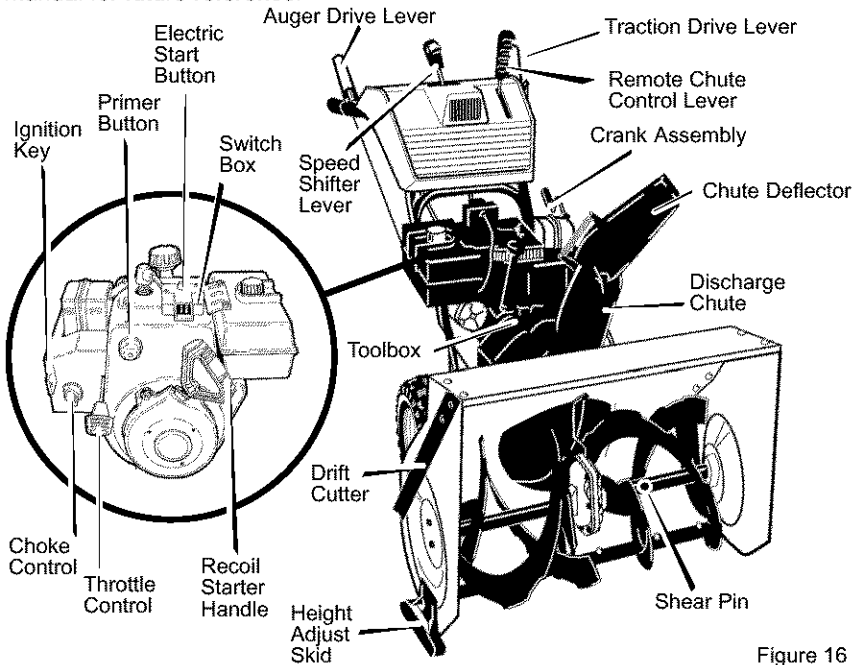

Figure 16

Auger Drive Lever – Starts and stops the auger and impeller (**snow gathering and throwing**)

Traction Drive Lever – Propels the snow thrower forward and in reverse.

Speed Shifter Lever – Selects the speed of the snow thrower (6 speeds forward and 2 speeds reverse).

Crank Assembly – Changes the direction of snow throwing through the discharge chute.

Chute Deflector – Changes the distance the snow is thrown.

Discharge Chute – Changes the height and direction the snow is thrown.

Height Adjust Skid – Adjusts the ground clearance of the auger housing.

Ignition Key – Must be inserted to start the engine.

Recoil Starter Handle – Starts the engine manually.

Choke Control – Used to start a cold engine.

Primer Button – Injects fuel directly into the carburetor manifold for fast starts in cold weather.

Remote Chute Control Lever – Push forward to discharge snow high and far. Pull remote lever back to discharge snow down.

Throttle Control – Controls the engine speed.

Electric Start Button – (if so equipped) Used to start the engine using the 120 V electric starter.

Shear Pin – Shear pins are designed to break (to protect the machine) if an object becomes lodged in the auger housing.

Toolbox – spare shear pins and spacers are located in toolbox.

Drift Cutter – Cuts a path through snow higher than the auger housing.

OPERATION

The operation of any snow thrower can result in foreign objects being thrown into the eyes, which can result in severe eye damage. Always wear safety glasses or eye shields while operating the snow thrower.

We recommend standard safety glasses or a wide vision safety mask for over your glasses.



WARNING: Read Owner's Manual before operating machine. Never direct discharge toward bystanders. Stop the engine before unclogging discharge chute or auger housing and before leaving the machine.

TO STOP YOUR SNOW THROWER

1. To stop throwing snow, release the **auger drive lever**. See Figure 17.
2. To stop the wheels, release the **traction drive lever**.
3. To stop the engine, push the **throttle control lever** to off and pull out the **ignition key**.

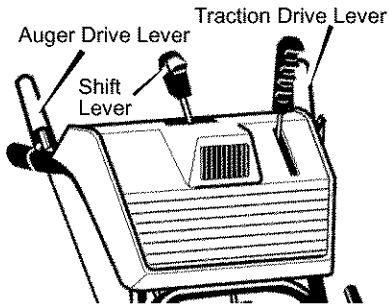
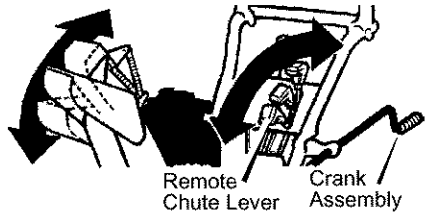

Figure 17

TO CONTROL SNOW DISCHARGE

1. Turn the **crank assembly** to set the direction of the snow throwing. See Figure 18.
2. Push the **remote chute lever** forward to discharge the snow high and far. Pull the **remote chute le-**

ver back to discharge the snow down.



Remote Chute Lever Crank Assembly

Figure 18

HOW TO MOVE FORWARD AND BACKWARD

1. To shift, release the traction drive lever (**left hand**) and move the speed shift lever to the speed you desire. See Figure 17. Ground speed is determined by snow conditions. Select the speed you desire by moving the speed shifter lever left into the appropriate notches on the shift lever plate:
Speeds 1,2 – Wet, Heavy
Speed 3 – Light
Speed 4 – Very Light
Speed 5,6 – Transport only
2. Engage the traction drive lever (**left hand**). As the snow thrower starts to move, maintain a firm hold on the handles, and guide the snow thrower along the clearing path. Do not attempt to push the snow thrower.
3. To move the snow thrower backward, move the speed shifter lever right into first or second reverse and engage the traction drive lever (**left hand**).

IMPORTANT: Do not move the speed shifter lever while the traction lever is down.

TO THROW SNOW

1. Push down the auger driver lever (**right hand**). See Figure 17.
2. Release to stop throwing snow.

OPERATION

HOW TO USE THE WHEEL LOCKOUT

The left wheel is secured to the axle with a lockout pin. See Figure 19. The unit was shipped with the lockout pin in the locked position. For ease of maneuverability in light snow conditions, disconnect the lockout pin as follows.

1. Pull the **knob** out to disengage the lockout pin.
2. To lock in the disengaged position, turn the **knob** 1/4 turn (90 degrees).

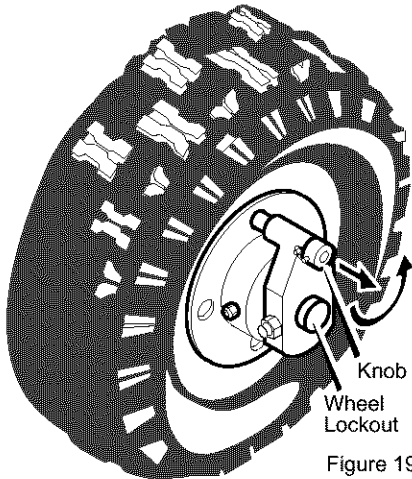

Figure 19

BEFORE STARTING THE ENGINE

1. Before you service or start the engine, familiarize yourself with the snow thrower. Be sure you understand the function and location of all controls.
2. Check the tension of clutch cable before starting the engine. See **To Adjust The Control Cable** paragraph in the **Service & Adjustments** section of this manual.
3. Be sure that all fasteners are tight.
4. Make sure the height adjust skids are properly adjusted. See **To Adjust Skid Height** paragraph in the **Service & Adjustments** section of this manual.

5. Check tire pressure (**14–17 pounds**). Do not exceed maximum amount of pressure.

CHECK THE OIL:

NOTE: The engine was shipped from the factory filled with oil. Check the level of the oil. Add oil as needed.

1. Make sure the unit is level.

NOTE: Do not check the level of the oil while the engine runs.

2. Remove the oil fill cap/dipstick. Check the oil.
3. If necessary, add oil until the oil reaches the FULL mark on the oil fill cap/dipstick (see Figure 20). Do not add too much oil.

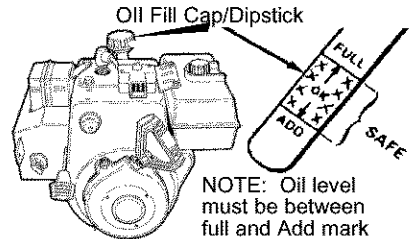

Figure 20

4. Tighten the fill cap/dipstick securely each time you check the oil level.

NOTE: For extreme cold operating conditions of 0°F and below, use a partial synthetic 0W30 motor oil for easier starting.

NOTE: S.A.E. 5W30 motor oil may be used to make starting easier in areas where temperature is consistently 20°F. or lower.

FILL GAS:

NOTICE: ENGINES WHICH ARE CERTIFIED TO COMPLY WITH CALIFORNIA AND US EPA EMISSION REGULATIONS FOR ULGE ENGINES: Are certified to operate on regular unleaded gasoline. Include the following emission control system(s): EM, TWC (**if so equipped**). Include any user adjustable features—therefore no other adjustments are needed.

OPERATION



WARNING: Experiences indicate that alcohol blended fuels (called gasohol or those using ethanol or methanol) can attract moisture which leads to separation and formation of acids during storage. Acidic gas can damage the fuel system of an engine while in storage.

NOTE: To avoid engine problems, the fuel system must be emptied before storage for 30 days or longer. Start the engine and let it run until the fuel lines and carburetor are empty. Use the carburetor bowl drain to empty residual gasoline from the float chamber. Use fresh fuel next season. See the Storage section in this manual for additional information.

Never use engine or carburetor cleaner products in the fuel tank or permanent damage may occur.

1. Fill the fuel tank only with a fresh, clean, unleaded regular, unleaded premium, or reformulated automotive gasoline. **DO NOT** use leaded gasoline. Make sure that the container you pour the gasoline from is clean and free from rust or other foreign particles. Never use gasoline that may be stale from long periods of storage in the container.



WARNING: Gasoline is flammable. Always use caution when handling or storing gasoline.

Do not fill fuel tank while snow thrower is running, when it is hot, or when snow thrower is in an enclosed area.

Keep away from open flame or an electrical spark and do not smoke while filling the fuel tank.

Never fill the tank completely. Fill the tank to within 1/4"–1/2" from the top to provide space for expansion of fuel.

Always fill fuel tank outdoors and use a funnel or spout to prevent spilling.

Make sure to wipe up any spilled fuel before starting the engine.

Store gasoline in a clean, approved container and keep the cap in place on the container.

TO STOP ENGINE

To stop engine, move the throttle control lever to "STOP" position and remove key. Keep the key in a safe place. The engine will not start without the key.

TO START ENGINE

(ELECTRIC STARTER, IF EQUIPPED)

Be sure that the engine has sufficient oil. The snow thrower engine is equipped with a 120 volt A.C. electric

OPERATION

starter and recoil starter. Before starting the engine, be certain that you have read the following information.



WARNING: The starter is equipped with a three-wire power cord and plug and is designed to operate on 120 volt AC household current. It must be properly grounded at all times to avoid the possibility of electrical shock which may be injurious to operator. Follow all instructions carefully as set forth in the "To Start Engine" section. Determine that your house wiring is a three-wire grounded system. Ask a licensed electrician if you are not sure. If your house wire system is not a three-wire system, do not use this electric starter under any conditions. If your system is grounded and a three-hole receptacle is not available at the point your starter will normally be used, one should be installed by a licensed electrician. When connecting 120 volt AC "Power Cord", always connect the cord to the Switch Box" on the engine first, then plug the other end into the three-hole grounded receptacle. When disconnecting "Power cord", always unplug the end in the three-hole grounded receptacle first.

COLD START

1. Be sure auger drive and traction drive levers are in the disengaged (RELEASED) position.
2. Move throttle control to "FAST" position.
3. Remove the keys from the plastic bag. Insert one key into ignition slot. Make sure it snaps into place. **Do not turn key.** Keep the second key in a safe place.
4. Rotate choke knob clockwise to the choke ON position.
5. Connect the power cord to the **switch box** on the engine.
6. Plug other end of power cord into a three-hole, grounded 120 VOLT, AC

F-001162J

receptacle. (See WARNING in this section).

7. Push the **primer button** while covering the vent hole as follows: Remove finger from primer button between primes.
Do not prime if temperature above 50° F (10° C).
Push two time if temperature is 50° F (10° C) to 15°F (-10° C).
Push four times if temperature is below 15° F (-10° C).
8. Push down on the **starter button** until the engine starts. Do not crank for more than 10 seconds at a time. This electric starter is thermally protected. If overheated it will stop automatically and can be restarted only when it has cooled to a safe temperature (a wait of about 5 to 10 minutes is required).
9. When the engine starts, release the **starter button** and move **choke lever** to "1/2 choke" position. When engine runs smoothly, move **choke lever** to "No Choke" Position.
10. Disconnect power cord from receptacle, first, and then from **switch box**.

NOTE: Allow the engine to warm up for several minutes before blowing snow in temperatures below 0°F.

11. Run engine at full throttle "FAST" when throwing snow.

WARM START

If restarting a warm engine after a short shutdown, leave choke at "OFF" and do not push the primer button. If the engine fails to start, follow the Cold Start instructions.

TO START ENGINE (RECOIL STARTER)

Be sure that the engine has sufficient oil. The snow thrower engine is equipped with a recoil starter. Before starting the engine, be certain that you have read the following information.

OPERATION

COLD START

1. Be sure auger drive and traction drive levers are in the disengaged (**RELEASED**) position.
2. Move throttle control to "**FAST**" position.
3. Remove the keys from the plastic bag. Insert one key into ignition slot. Make sure it snaps into place. **Do not turn key.** Keep the second key in a safe place.
4. Rotate choke knob clockwise to the choke ON position.
5. Push the **primer button** while covering the vent hole as follows: Remove finger from primer button between primes.

Do not prime if temperature above 50° F (10° C).

Push two times if temperature is 50° F (10° C) to 15°F (-10° C).

Push four times if temperature is below 15° F (-10° C).

6. Pull the **starter handle** rapidly. Do not allow the handle to snap back, but allow it to rewind slowly while keeping a firm hold on the **starter handle**.
7. As the engine warms up, move **choke lever** to "1/2 choke" position. When engine runs smoothly, move **choke lever** to "No Choke" Position.

NOTE: Allow the engine to warm up for several minutes before blowing snow in temperatures below 0°F.

8. Run engine at full throttle "**FAST**" when throwing snow.

WARM START

If restarting a warm engine after a short shutdown, leave choke at "**OFF**" and do not push the primer button. If the en-

gine fails to start, follow the Cold Start instructions.

FROZEN STARTER

If the starter is frozen and will not turn engine:

1. Pull as much rope out of the starter as possible.
2. Release the starter handle and let it snap back against the starter.

If the engine still fails to start, repeat the two previous steps until the engine starts. Then continue with the directions for cold start.

To help prevent possible freeze-up of recoil starter and engine controls, proceed as follows after each snow removal job.

1. With the engine running, pull the starter rope hard with a continuous full arm stroke three or four times. Pulling of starter rope will produce a loud clattering sound. This is not harmful to the engine or starter.
2. With the engine not running, wipe all snow and moisture from the carburetor cover in area of control levers. Also move throttle control, choke control, and starter handle several times.



WARNING: Never run engine indoors or in enclosed, poorly ventilated areas. Engine exhaust contains **CARBON MONOXIDE, AN ODORLESS AND DEADLY GAS.** Keep hands, feet, hair and loose clothing away from any moving parts on engine and snow thrower.

The temperature of muffler and nearby areas may exceed 150°F. Avoid these areas.

DO NOT allow children or young teenagers to operate or be near snow thrower while it is operating.

OPERATION



WARNING: Do not attempt to remove any item that may become lodged in auger without taking the following precautions:

- Release auger drive lever.
- Move throttle lever to stop position.
- Remove (do not turn) ignition key.
- Disconnect spark plug wire.
- Do not place your hands in the auger or discharge chute. Use a pry bar.

SNOW THROWING TIPS

1. For maximum snow thrower efficiency in removing snow, adjust ground speed, NEVER the throttle. Go slower in deep, freezing or wet snow. If the wheels slip, reduce forward speed. The engine is designed to deliver maximum performance at full throttle and should be run at this power setting at all times.
2. Most efficient snow throwing is accomplished when the snow is removed immediately after it falls.
3. For complete snow removal, slightly overlap each path previously taken.
4. The snow should be discharged down wind whenever possible.
5. For normal usage, set the skids so that the scraper bar is 1/8" above the skids. For extremely hard-packed snow surfaces, adjust the skids upward so that the scraper bar touches the ground.
6. On gravel or crushed rock surfaces, set the skids at 1-1/4" below the scraper bar. See **To Adjust Skid Height** paragraph in the **Service & Adjustments** section of this manual. Rocks and gravel must not be picked up and thrown by the machine.
7. After the snow throwing job has been completed, allow the engine to idle for a few minutes, which will melt snow and accumulated ice off the engine.
8. Clean the snow thrower thoroughly after each use.
9. Remove ice and snow accumulation and all debris from the entire snow thrower, and flush with water (if possible) to remove all salt or other chemicals. Wipe snow thrower dry.

MAINTENANCE

CUSTOMER RESPONSIBILITIES

| SERVICE RECORDS Fill in dates as you complete regular service. | Before Each Use | Often | Every 5 Hours | Every 10 Hours | Every 25 Hours | Each Season | Before Storage | SERVICE DATES |
|---|-----------------------|-------|---------------------|----------------------|----------------------|----------------|-------------------|------------------|
| Check Engine Oil Level | √ | | √ | | | √ | | |
| Change Engine Oil | | | | | √ | √ | | |
| Tighten All Screws and Nuts | √ | √ | | | | | | |
| Check Spark Plug | | | | | √ | √ | | |
| Lubricate All Pivot Points | | | | √ | | | √ | |
| Lubricate Disc Drive Plate Zerk (See Maintenance) | | | | | | | √ | |
| Check Fuel | √ | | | | | | | |
| Drain Fuel | | | | | | | √ | |
| Check Cable Adjustment (See Cable Adjustment) | | | | | | √ | | |
| Adjust Drive Belt | √ | | | | √ | √ | | |
| Lubricate Auger Shaft (See Shear Bolt Replacement) | | | | √ | | | √ | |

GENERAL RECOMMENDATIONS

The warranty on this snow thrower does not cover items that have been subjected to operator abuse or negligence. To receive full value from the warranty, the operator must maintain the snow thrower as instructed in this manual.

Some adjustments will need to be made periodically to properly maintain your snow thrower.

All adjustments in the **Service and Adjustments** section of this manual should be checked at least once each season.

AFTER EACH USE

- Check for any loose or damaged parts.
- Tighten any loose fasteners.
- Check and maintain the auger.
- Check controls to make sure they are functioning properly.

- If any parts are worn or damaged, replace immediately.

LUBRICATION CHART

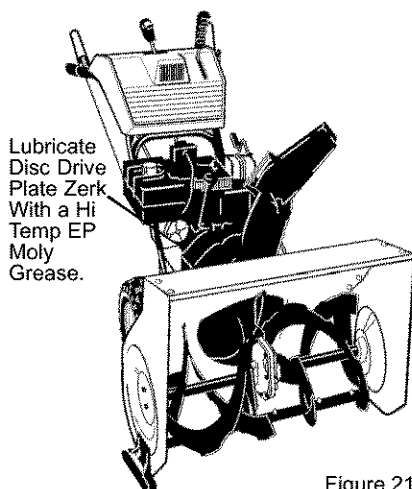

Figure 21

MAINTENANCE

PRODUCT SPECIFICATIONS

| | |
|-------------------------------|--|
| HORSEPOWER | 12.5 HP |
| DISPLACEMENT | 21.82 cu. in. |
| GASOLINE CAPACITY | 4 quarts (unleaded) |
| OIL CAPACITY (20 oz capacity) | 5W30 |
| SPARK PLUG: | Champion RJ19LM (Gap .030 in.) or equivalent |
| VALVE CLEARANCE: | Intake: .010 In. Exhaust: .010 In. |

SNOW THROWER

AS REQUIRED

The following adjustment should be performed more than once each season.

1. Auger drive belt should be adjusted after the first 2 to 4 hours of use, again about mid-season and twice each season thereafter (**See to Adjust Belts paragraph in the Service and Adjustment section**).

LUBRICATION – EVERY 10 HOURS

1. **Auger Shaft** – Using a hand grease gun, lubricate the auger shaft zerk fittings (**A**) every ten (**10**) operating hours. Each time a shear bolt is replaced, the auger shaft **MUST** be greased. See Figure 22. See **To Replace Auger Shear Bolt** in the **Service and Adjustment** section.

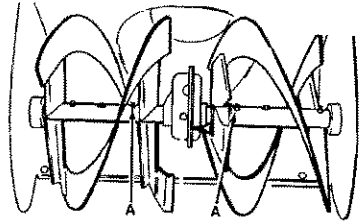

Figure 22

LUBRICATION—EVERY 25 HOURS

Lubricate Disc Drive Plate every twenty-five (**25**) hours and at the end of the season and/or before storage.

To Lubricate

1. Position speed selector lever in first gear.
2. Stand the snow thrower up on the auger housing end.
3. Remove the bottom panel.
4. Turn **disc drive plate** clockwise by hand until **grease zerk** is clearly visible at front center. See Figure 23.
5. Place a **coin** or (**a shim of equal thickness**) between the rubber **friction wheel** and **disc drive plate** to prevent rubber friction wheel contacting the **drive disc plate**.
6. To **grease zerk**, use a hand grease gun, lubricate with a Hi Temp EP Moly grease. Fill zerk only until grease becomes visible below bearing assembly located under grease zerk. **DO NOT** over fill.

CAUTION: DO NOT allow grease to come in contact with the **disc drive plate** or **friction wheel** or damage will result.

IMPORTANT: Remove **coin** and ensure that a gap exists between **friction wheel** and **disc drive plate**.

MAINTENANCE

NOTE: Clean all excess grease found on friction disc hub.

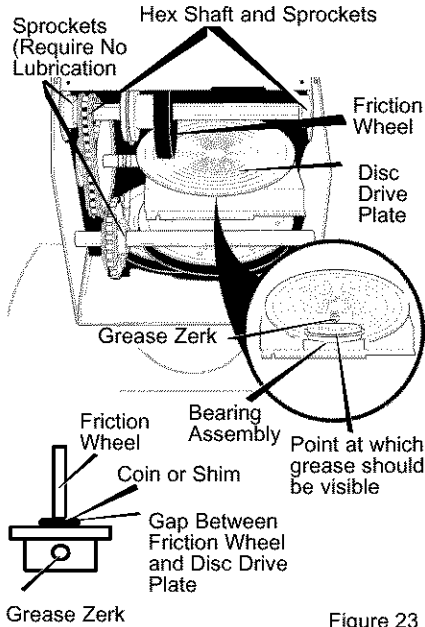

LUBRICATION—NOT REQUIRED

1. **Hex Shaft and Sprockets** – Hex shaft and sprockets require no lubrication. All bearings and bushings are lifetime lubricated and require no maintenance. See Figure 23.

NOTE: Any greasing or oiling of the above components can cause contamination of the friction wheel. If the disc drive plate or friction wheel come in contact with grease or oil, damage to the friction wheel will result.

Should grease or oil come in contact with the disc drive plate or friction wheel, be sure to clean the plate and wheel thoroughly.

NOTE: For storage, the hex shaft and sprockets should be wiped with 5W30 motor oil to prevent rusting.

2. **Auger Gear Box** – The auger gear box is lubricated at the factory and should not require additional lubrication. If for some reason the lubricant should leak out, have auger gear case checked by a competent repairman.

ENGINE

LUBRICATION

Check the crankcase oil level before starting the engine and after each five (5) hours of continuous use. See Figure 24. Add S.A.E. 5W30 motor oil as needed. Tighten fill cap/dipstick securely each time you check the oil level.

Oil Fill Cap/Dipstick

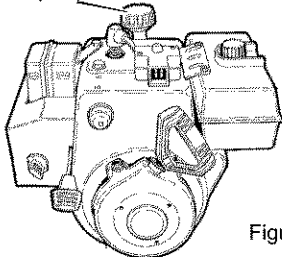

Change the oil every twenty–five (25) hours or at least once a year if the snow thrower is not used for twenty–five (25) hours.

TO CHANGE ENGINE OIL

1. Position the snow thrower so that the oil drain plug is at the lowest point on the engine.
2. Remove the oil drain plug and the **oil fill cap/dipstick**. Drain the oil into a suitable container.
NOTE: The oil will drain more freely when the engine is warm.
3. After draining all the oil, reinstall the oil drain plug securely.
4. Fill the engine crankcase with S.A.E. 5W30 motor oil, pouring slowly. **DO NOT OVERFILL.**

SERVICE AND ADJUSTMENT



WARNING: Always disconnect the spark plug wire and place it where it cannot make contact with spark plug to prevent accidental starting when making any adjustments or repairs.

TO ADJUST SKID HEIGHT

This snow thrower is equipped with two height adjustment skids, located on the outside of the auger housing. See Figure 25.

These skids elevate the front of the snow thrower.

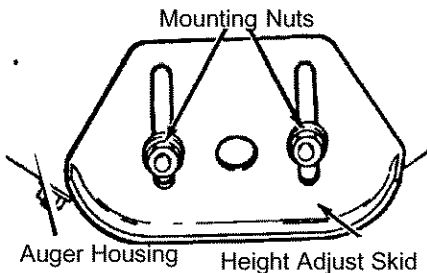

Figure 25

For normal hard surfaces, such as a paved driveway or walk, adjust the skids as follows.

1. Position the snow thrower on a level surface.
2. Make sure both tires are equally inflated. Proper tire pressure is 14 to 17 PSI. See side of tire for maximum inflation. Do not exceed sidewall maximum pressure on tire.
3. Place the extra shear bolts supplied (**found in parts bag**) under each end of the scraper bar next to the adjustable skids.
4. Loosen the mounting nuts that hold the adjustable skids. To bring the front of the snow thrower down,

raise the adjustable skids. Tighten the mounting nuts. See Figure 25.

NOTE: For rocky or uneven surfaces, raise the front of the snow thrower by moving the skids down.



WARNING: Be certain to maintain proper ground clearance for your particular area to be cleared. Objects such as gravel, rocks or other debris, if struck by the impeller, may be thrown with sufficient force to cause personal injury, property damage or damage to the snow thrower.

TO ADJUST SCRAPER BAR

After considerable use, the metal scraper bar will have a definite wear pattern. The scraper bar in conjunction with the skids should always be adjusted to allow 1/8" between the scraper bar and the sidewalk or area to be cleaned.

1. Position the snow thrower on a level surface.
2. Make sure both tires are equally inflated. Proper tire pressure is 14 to 17 PSI. See side of tire for maximum inflation. Do not exceed sidewall maximum pressure on tire.
3. Loosen the carriage bolts and nuts securing the scraper bar to the auger housing.
4. Adjust the scraper bar to the proper position.
5. Tighten the carriage bolts and nuts, making sure that the scraper bar is parallel with the working surface.
6. For extended operation, the scraper bar may be reversed. If the scraper bar must be replaced due to wear, remove the carriage bolts and nuts and install a new scraper bar.

SERVICE AND ADJUSTMENT

HOW TO CHECK AND ADJUST THE CABLES

The cables are adjusted at the factory and no adjustment should be necessary. If the cables have become stretched or are sagging adjustment will be necessary.

To check for correct adjustment, disconnect the **Z-fitting** at the **drive lever**, move the **drive lever** to the full forward position, just contacting the **plastic bumper**. The control cables are correctly adjusted when the center of the **"Z" fitting** is between the center and top of the hole in the **drive lever** and there is no droop in the cable.

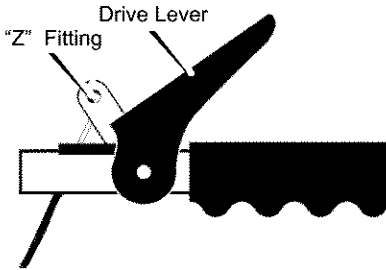

Figure 26

1. Remove gas from gas tank. Stand snow thrower on end.
2. Disconnect the **"Z" fitting** from **drive lever**.
3. Pull spring cover up to expose **spring**. Push the cable through the **spring** to expose the threaded portion of the cable. See Figure 27.
4. Hold the **square end** of the threaded portion with pliers and adjust the **locknut** in or out until the excess slack is removed.

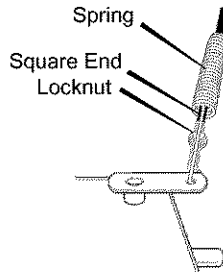

Figure 27

5. Pull the cable back through the **spring** and connect the cable. Do the same for the other drive lever cable, if needed.

NOTE: Whenever the traction drive or auger belts are adjusted or replaced, the cables will need to be adjusted.

TO ADJUST BELTS

Belts stretch during normal use. If you need to adjust the belts due to wear or stretch, proceed as follows:

How To Adjust The Auger Drive Belt

If your snow thrower will not discharge snow, check the control cable adjustment. If it is correct, then check the condition of the auger drive belt. It may be loose or damaged. If it is damaged, replace it. See **To Replace Belts** paragraph in this section. If the auger drive belt is loose, adjust as follows:

1. Disconnect the spark plug wire.
2. Remove the **belt cover**. See Figure 28.

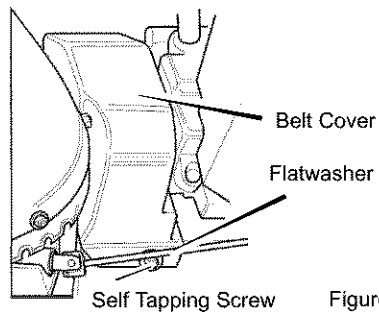

Figure 28

SERVICE AND ADJUSTMENT

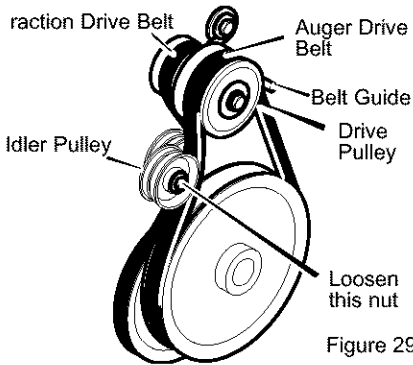

Figure 29

3. Loosen the **nut** on the **idler pulley** and move the pulley toward the belt about 1/8". See Figure 29.
4. Tighten the **nut**.
5. Press the auger drive lever. Check the tension on the belt (opposite **auger idler pulley**). The belt should deflect about 1/2" with moderate pressure (See Figure 30).

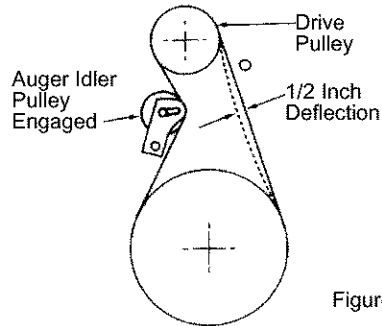

Figure 30

NOTE: If the adjustment is not correct, repeat the adjustment.

6. Replace the belt cover.
7. Check the clutch control cable adjustment.
8. Reconnect the spark plug wire.

Traction Drive Belt

The traction drive belt has constant spring pressure and does not require adjustment. Replace the traction drive belt if it is slipping. See **To Replace Belts** paragraph in this section.

TO REPLACE BELTS

The drive belts on this snow thrower are of special construction and should be replaced with original equipment belts available from your nearest Sears Store. A distributor's list is supplied in the parts manual.

You will need the assistance of a second person while replacing the belts.

How To Remove The Auger Drive Belt

If the auger drive belt is damaged, the snow thrower will not discharge snow. Replace the damaged belt as follows.

1. Remove the gas from the gas tank. Stand the snow thrower up on the front end of the auger housing.



WARNING: Drain the gasoline outdoors, away from fire or flame.

2. Disconnect the spark plug wire.
3. Remove the **screw** from the **belt cover**. Remove the **belt cover**. See Figure 28.
4. Remove the **bolts** on each side of the **motor mount frame**. See Figure 31.
5. Loosen the **bolts** on each side of the **motor mount frame**. The **auger housing** and the **motor mount**

SERVICE AND ADJUSTMENT

frame will separate, hinged by the bolts.

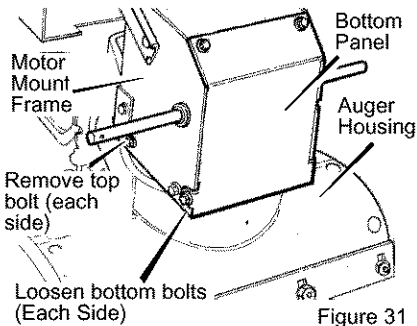

Figure 31

6. Loosen the **belt guide**. Pull the **belt guide** away from the **auger drive pulley**. See Figure 29.
 7. Loosen the **nut** on the **idler pulley**. Pull the **idler pulley** away from the **auger drive belt**.
 8. Remove the old **auger drive belt**. Replace the **auger drive belt** with an original factory replacement belt available from an authorized service center.
 9. Install the new **auger drive belt** onto the **auger drive pulley** and onto the **drive pulley**.
 10. Adjust the **auger drive belt**. See "How To Adjust The Auger Drive Belt" in the Service And Adjustment section.
 11. Adjust the **belt guide**. See "How To Adjust The Belt Guide" in the Service And Adjustment section.
 12. Install the **bolts** on each side of the **motor mount frame**. See Figure 31.
 13. Tighten the **bolts** on each side of the **motor mount frame**.
 14. Install the **belt cover**. Tighten the **screw**. See Figure 28.
 15. Check the adjustment of the cables. See "How To Check And Adjust The Cables" in the Service And Adjustment section.
16. Connect the spark plug wire.

F-001162J

How To Remove the Traction Drive Belt

If the snow thrower will not move forward, check the traction drive belt for wear or damage. If the traction drive belt is worn or damaged, replace the belt as follows.

1. Remove the gas from the gas tank. Stand the snow thrower up on the front end of the auger housing.



WARNING: Drain the gasoline outdoors, away from fire or flame.

2. Disconnect the spark plug wire.
3. Remove the auger drive belt. See "How To Remove The Auger Drive Belt" in the Maintenance section.
4. Pull the traction drive idler pulley away from the traction drive belt. See Figure 32.

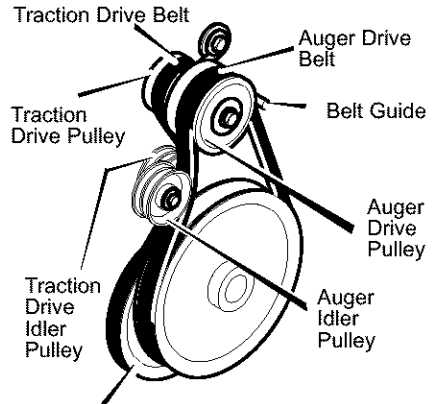

Figure 32

5. Remove the old traction drive belt from the traction drive pulley and from the engine pulley. Replace the traction drive belt with an original factory replacement belt available from an authorized service center.
6. Install the new traction drive belt onto the traction drive pulley and onto the engine pulley.
7. Make sure the traction drive idler pulley is properly aligned with the traction drive belt.
8. Install and adjust the auger drive belt. See "How To Remove The Au-

SERVICE AND ADJUSTMENT

ger Drive Belt" in the Service And Adjustment section.

- Adjust the belt guide. See "How To Adjust The Belt Guide" in the Service And Adjustment section.
- Install the bolts on each side of the motor mount frame. See Figure 31.
- Tighten the bolts on each side of the motor mount frame.
- Install the belt cover. Tighten screw. See Figure 28.
- Check the adjustment of the cables. See "How To Check And Adjust The Cables" in the Service And Adjustment section.
- Connect the spark plug wire.

HOW TO ADJUST THE BELT GUIDE

- Disconnect spark plug wire.
- Remove the **screw**. Remove the **belt cover**. See Figure 28.
- Engage the **auger drive lever**.

- Measure the distance between the **belt guide** and **auger drive belt**. The **correct distance** is 1/8 inch (3.175 mm). See Figure 33.

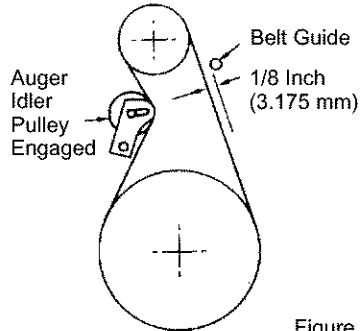

Figure 33

- If an adjustment is necessary, loosen the mounting bolt for the **belt guide**. Move the **belt guide** to the **correct position**. Tighten the mounting bolt for the **belt guide**.
- Install the **belt cover**. Tighten the **screw**. See Figure 28.
- Connect the spark plug wire.

HOW TO ADJUST OR REPLACE THE FRICTION WHEEL

How To Check The Friction Wheel

If the snow thrower will not move forward, check the traction drive belt, the traction drive cable or the friction wheel. If the friction wheel is worn or damaged, it must be replaced. See "How To Replace the Friction Wheel" in this section. If the friction wheel is not worn or damaged, check as follows.

- Remove the gas from the gas tank. Stand the snow thrower up on the front end of the auger housing.

 **WARNING:** Drain the gasoline outdoors, away from fire or flame.

- Disconnect the spark plug wire.

F-001162J

- Remove the **bolts** on each side of the **bottom panel**. See Figure 34.
- Loosen the **bolts** on each side of the **bottom panel**.
- Remove the **bottom panel**.

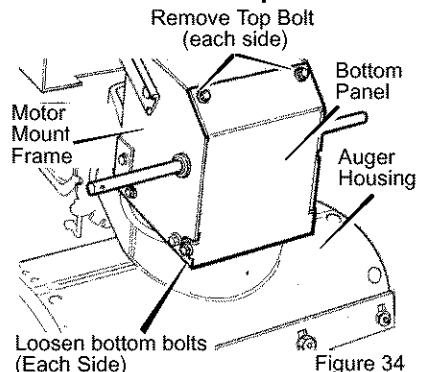

Figure 34

- Position the **shift speed lever** in the first forward gear.
- Note the position of the **friction wheel** on the **disc drive plate** (See

SERVICE AND ADJUSTMENT

Figure 35). In the correct position, the right outer side of the **disc drive plate** must be three inches (7.62cm.) from the center of the **friction wheel**. If the **friction wheel** is not in the correct position, adjust as follows.

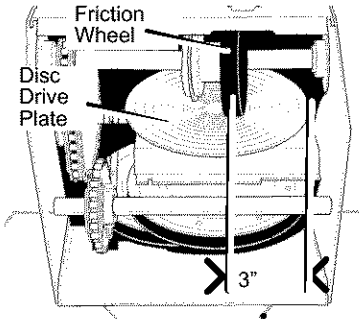

Figure 35

How To Adjust The Friction Wheel

1. Loosen the **nut** on the **speed control rod**. See Figure 36.
2. Remove the **fasteners** to disconnect the **ball joint** from the **shift yoke assembly**. To lengthen or shorten the **speed control rod**, turn the **adaptor** to obtain the correct friction wheel position.
3. Assemble the **ball joint** to the **shift yoke assembly** with the **fasteners**.
4. Tighten **nut** on the **speed control rod**.
5. Make sure the **speed select lever** functions correctly. Move the **speed select lever** through all speeds.
6. Install the **bottom panel**. See Figure 34.
7. Tighten the **bolts** on each side of the **bottom panel**.
8. Install the **bolts** on each side of the **bottom panel**.

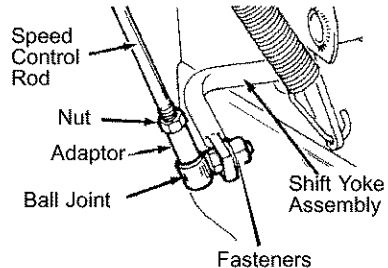

Figure 36

How To Replace The Friction Wheel

If the friction wheel is worn or damaged, the snow thrower will not move forward. The friction wheel must be replaced as follows.

1. Remove the gas from the gas tank. Stand the snow thrower up on the front end of the auger housing.



WARNING: Drain the gasoline outdoors, away from fire or flame.

2. Disconnect the spark plug wire.
3. Remove the **top bolts** on each side of the **bottom panel**. See Figure 34.
4. Loosen the **bottom bolts** on each side of the **bottom panel**.
5. Remove the **bottom panel**.
6. Remove the **speed control rod** from the **shift yoke assembly**. See Figure 36.
7. Remove the three **fasteners** that hold the **friction wheel** to the **hub**. See Figure 37.

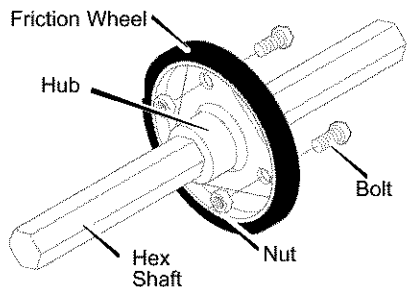

Figure 37

SERVICE AND ADJUSTMENT

- Remove the four bolts that hold the **bearing plates** on each side of the **hex shaft**. See Figure 38.

NOTE: Take special note of the position of the washers and retaining ring on the hex shaft and the sprocket assembly.

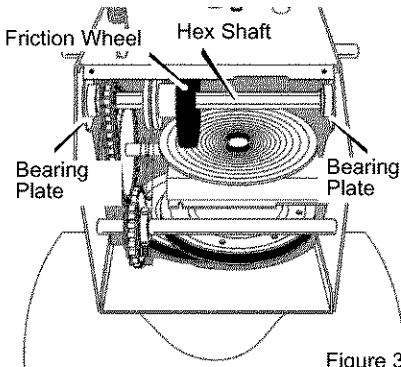

Figure 38

- Remove the **bearing plate** from the right side. Do not remove the **hex shaft**. Leave the **hex shaft** in position. Carefully raise **hex shaft** just enough to allow the **friction wheel** to be removed.
- Remove the **friction wheel** from the **hub**. Slip the **friction wheel** toward the right off the **hex shaft**. See Figure 37.
- Assemble the new **friction wheel** onto **hub** with the fasteners removed earlier.
- Install the **bearing plate** onto the right side. Make sure the **hex shaft** is engaged with both **bearing plates** and that the washers and retaining ring are installed in the original position. See Figure 38.
- Fasten the **bearing plates** using the four bolts removed earlier.
- Make sure the **hex shaft** turns freely.
- Attach the **speed control rod** to the **shift yoke assembly**. See Figure 36.
- Check the adjustment of the friction wheel. See "How To Adjust The Friction Wheel" in this section.
- Make sure the friction wheel and the disc drive plate are free from grease or oil.
- Install the **bottom panel**. See Figure 34.
- Tighten the **bottom bolts** on each side of the **bottom panel**.
- Install the **top bolts** on each side of the **bottom panel**.
- Connect the spark plug wire.

HOW TO REPLACE THE AUGER SHEAR BOLT

The augers are secured to the auger shaft with special shear bolts. These shear bolts are designed to break and protect the machine if an object becomes lodged in the auger housing. Do not use a harder bolt as the protection provided by the shear bolt will be lost.



WARNING: For safety and to protect the machine, use only original equipment shear bolts.

To replace a broken shear bolt, proceed as follows. Extra shear bolts were provided in the assembly parts bag.

- Move the throttle control to the stop position. Disengage all controls.
- Disconnect the spark plug wire. Make sure all moving parts have stopped.

SERVICE AND ADJUSTMENT

3. Align the hole in the auger with the hole in the auger shaft. Install the new **shear pin** and **spacer**. See Figure 39.
4. Connect the spark plug wire.

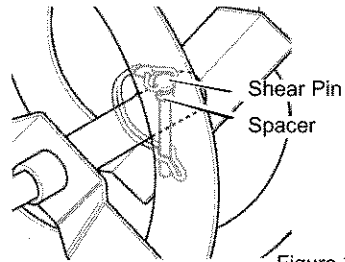

Figure 39

TO ADJUST THE CARBURETOR

If you think your carburetor needs adjusting, see your nearest Sears Store. Engine performance should not be affected at altitudes up to 7,000 feet. For operation at higher elevations, contact your nearest Sears Store.

IMPORTANT: Never tamper with the engine governor, which is factory set for proper engine speed. Over-speeding the engine above the factory high speed setting can be dangerous. If you think the engine-governed high speed needs adjusting, contact your nearest Sears Store, which has the proper equipment and experience to make any necessary adjustments.

TO ADJUST OR REPLACE THE SPARK PLUG

NOTE: This spark ignition system meets all requirements of the Canadian Interference-Causing Equipment Regulations.

If you have difficulty starting the snow thrower, adjust or replace the spark plug. Replace the spark plug if the electrodes are pitted or burned or if the porcelain is cracked. Follow the instructions below.

To adjust:

1. Clean **spark plug** by carefully scraping the electrodes (**Do not sand blast or use a wire brush**).
2. Be sure **spark plug** is clean and free of foreign material. Check electrodes gap with a wire **feeler gauge** and reset gap to 0.030" if necessary. See Figure 40.

To Replace:

1. If you need a new spark plug, use only the proper replacement spark plug.
2. Set the gap to 0.030 inches.
3. Before installing the spark plug, lightly coat the spark plug threads with oil or grease to insure easy removal.
4. Firmly tighten the spark plug in the engine.
5. If a torque wrench is available, torque the plug to 18 to 23 foot pounds.

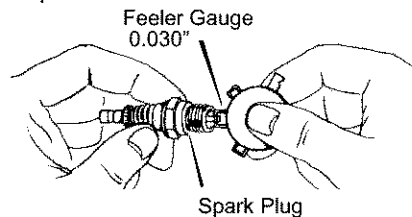

Figure 40

STORAGE



WARNING: Never store your snow thrower indoors or in an enclosed, poorly ventilated area. If gasoline remains in the tank, fumes may reach an open flame, spark or pilot light from a furnace, water heater, clothes dryer, cigarette, etc.

NOTE: To prevent engine damage (if snow thrower is not used for more than 30 days) follow the steps below.

SNOW THROWER

1. Thoroughly clean the snow thrower.
2. Lubricate all lubrication points. See the **Maintenance** section.
3. Be sure that all nuts, bolts and screws are securely fastened. Inspect all visible moving parts for damage, breakage and wear. Replace if necessary.
4. Touch up all rusted or chipped paint surfaces; sand lightly before painting.
5. Cover the bare metal parts of the blower housing auger and the impeller with rust preventative, such as a spray lubricant.

NOTE: A yearly checkup or tune-up by a Sears service center is a good way of ensuring that your snow thrower will provide maximum performance for the next season.

ENGINE



WARNING: Drain the gasoline outdoors, away from fire or flame.

Gasoline must be removed or treated to prevent gum deposits from forming in the fuel tank, filter, hose, and carburetor during storage. Also, during storage alcohol blended gasoline that uses ethanol or methanol (sometimes called gasohol) attracts water. It acts on the gasoline to form acids which damage the engine.

F-001162J

1. To remove gasoline, run the engine until the fuel tank is empty and the engine stops.
2. If you do not remove the gasoline, use fuel stabilizer supplied with unit or purchase Craftsman Fuel Stabilizer No. 3550. Add fuel stabilizer to any gasoline left in the tank to minimize gum deposits and acids. If the fuel tank is almost empty, mix stabilizer with fresh gasoline in a separate container and add some to the fuel tank.
3. Always follow the instruction on the stabilizer container. After the stabilizer is added to the fuel tank, run the engine at least ten minutes to allow the mixture to reach the carburetor.
4. Change the engine oil.
5. Lubricate the piston/cylinder area. First, remove the spark plug and squirt a few drops of clean engine oil into the spark plug hole. Next, cover the spark plug hole with a rag to absorb oil spray. Then, pull two or three times on the recoil starter rope to rotate the engine. Finally, install the spark plug and attach the spark plug wire.

OTHER

1. If possible, store your snow thrower indoors and cover it to give protection from dust and dirt.
2. If the machine must be stored outdoors, block up the snow thrower to be sure the entire machine is off the ground.
3. Cover the snow thrower with a suitable protective cover that does not retain moisture. Do not use plastic.

IMPORTANT: Never cover snow thrower while engine and exhaust areas are still warm.

TROUBLE SHOOTING

| TROUBLE | CAUSE | CORRECTION |
|---|--|--|
| Difficult starting | Defective spark plug. | Replace spark plug. |
| | Water or dirt in fuel system. | Use carburetor bowl drain to flush and refill with fresh fuel. |
| Engine runs erratic | Blocked fuel line, empty gas tank, or stale gasoline | Clean fuel line; check fuel supply; add fresh gasoline |
| Engine stalls | Unit running on CHOKE. | Set choke lever to RUN position. |
| Engine runs erratic; Loss of power | Water or dirt in fuel system. | Use carburetor bowl drain to flush and refill with fresh fuel. |
| Excessive vibration | Loose parts: damaged impeller | Stop engine immediately and disconnect spark plug wire. Tighten all bolts and make all necessary repairs. If vibration continues, have the unit serviced by a Sears service repairman. |
| Unit fails to propel itself | Drive belt loose or damaged. | Replace drive belt. |
| | Incorrect adjustment of traction drive cable | Adjust traction drive cable. |
| | Worn or damaged friction wheel. | Replace friction wheel. |
| Unit fails to discharge snow | Auger drive belt loose or damaged. | Adjust auger drive belt; replace if damaged. |
| | Auger control cable not adjusted correctly. | Adjust auger control cable. |
| | Shear bolt broken | Replace shear bolt |
| | Discharge chute clogged. | Stop engine immediately and disconnect spark plug wire. Clean discharge chute and inside of auger housing. |
| | Foreign object lodged in auger | Stop engine immediately and disconnect spark plug wire. Remove object from auger. |

CRAFTSMAN 33" 12.5HP SNOW THROWER 536.881121

FRAME ASSEMBLY

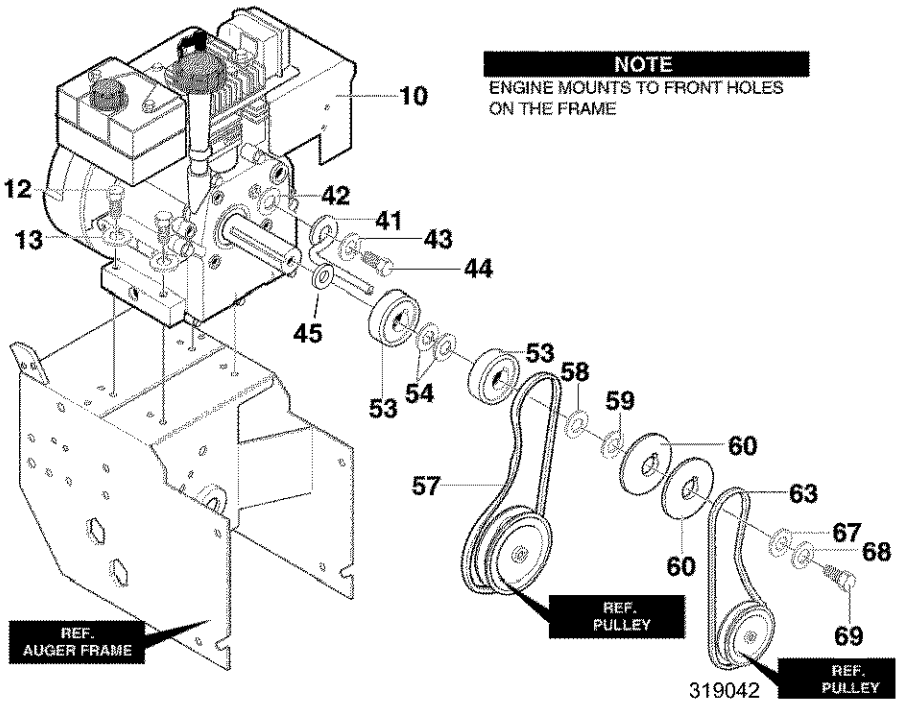

| Key No. | Description | Part No. |
|---------|----------------------|-----------|
| 10 | MODEL 143.011201 | ENGINE |
| 12 | SCREW, 5/16-18 | 710024 |
| 13 | WASHER | 71060 |
| 41 | GUIDE, ROD BELT | 3949 |
| 42 | PLASTIC WASHER | 6711 |
| 43 | WASHER | 71060 |
| 44 | SCREW, 5/16-24X 1.00 | 910828 |
| 45 | SPACER | 762291 |
| 53 | PULLEY, HALF | 579854 |
| 54 | WASHER, FLAT | 579861 |
| 57 | BELT, V | 302707 |
| 58 | FLATWASHER | 712120 |
| 59 | SPACER, SLEEVE | 586251 |
| 60 | PULLEY, ENGINE | 586253 |
| 63 | BELT, V | 761788 |
| 67 | WASHER, FLAT | 50677 |
| 68 | WASHER | 71063 |
| 69 | SCREW, 3/8-24X1.00 | 71015 |
| — | OWNER'S MANUAL | F-001162J |

CRAFTSMAN 33" 12.5HP SNOW THROWER 536.881121
ELECTRIC START ASSEMBLY

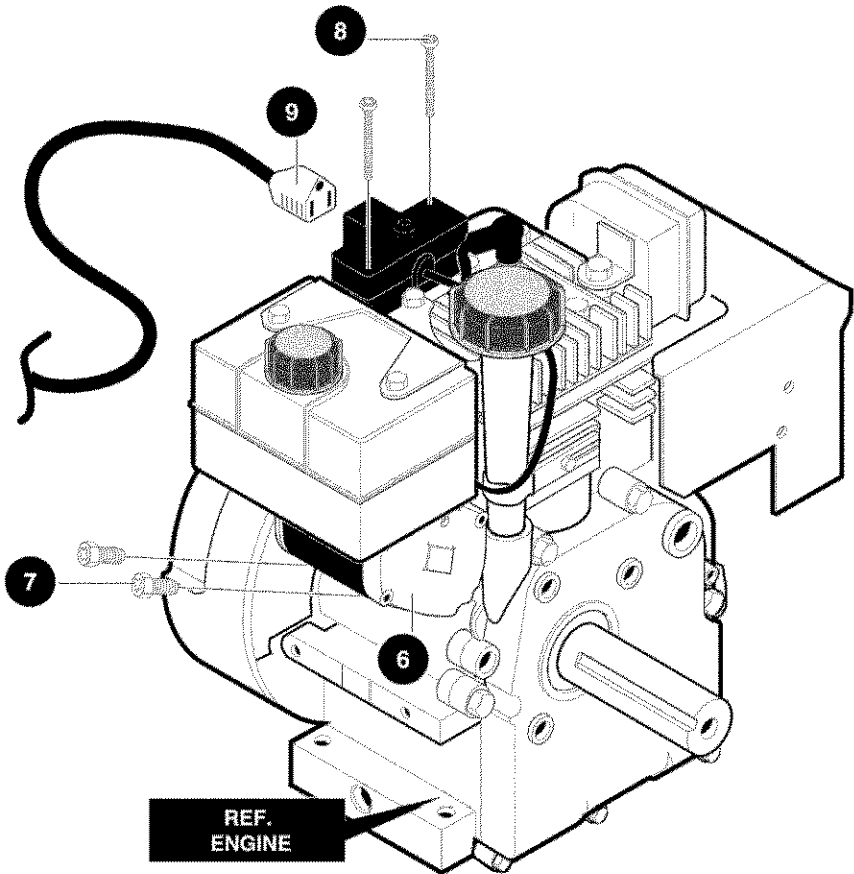

319051

| Key No. | Description | Part No. |
|---------|----------------|----------|
| 6 | MOTOR, STARTER | 762323 |
| 7 | SCREW | 6216 |
| 8 | SCREW | 6217 |
| 9 | CORD, STARTER | 6219 |

CRAFTSMAN 33" 12.5HP SNOW THROWER 536.881121

FRAME ASSEMBLY

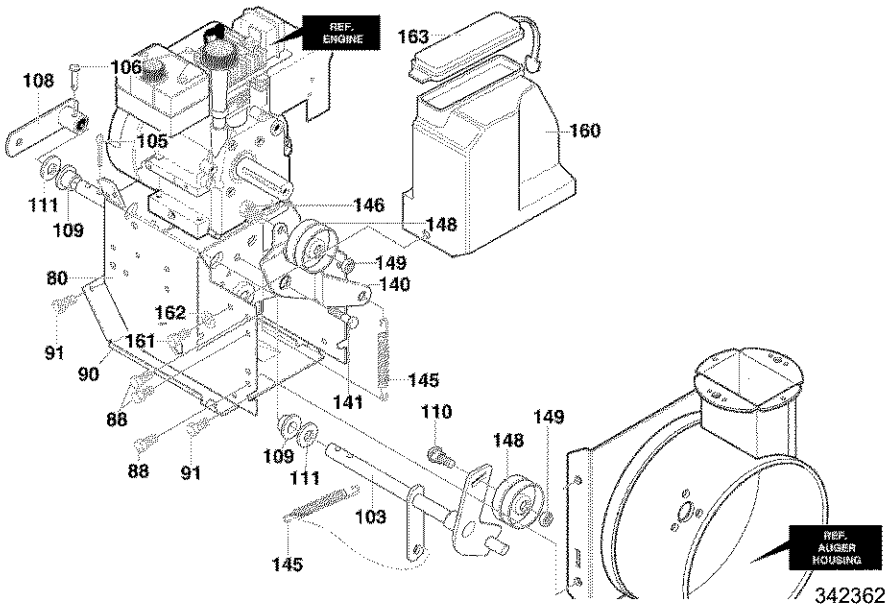

| Key No. | Description | Part No. |
|---------|-----------------------------|------------|
| 80 | FRAME ASSY | 761705-848 |
| 88 | SCREW, 5/16-18X .50 | 780055 |
| 90 | COVER, BOTTOM | 583031-853 |
| 91 | SCREW, 1/4-20X .63 | 310169 |
| 103 | IDLER ASSEMBLY | 762296 |
| 105 | PIN, HAIR .38DIA X 1.64LG | 711682 |
| 106 | PIN, KLIK 3/16" DIA | 761761 |
| 108 | ASSY., SPRING ATTACH | 761766 |
| 109 | BEARING, FL. | 53703 |
| 110 | BOLT, 3/8-16X 1.25 CARR. | 585781 |
| 111 | WASHER, FLAT | 711617 |
| 140 | LEVER, IDLER ARM TRACTION | 761701 |
| 141 | BOLT, .625X.135 HSH 5/16-18 | 329989 |
| 145 | IDLER SPRING TRACTION DRIVE | 53704 |
| 146 | SCREW, 3/8-16X 1.25 | 761760 |
| 148 | PULLEY, IDLER | 50793 |
| 149 | NUT, 3/8-16 | 590 |
| 160 | COVER, BELT | 760478 |
| 161 | SCREW, 1/4-20X .63 | 310169 |
| 162 | WASHER, FLAT | 71067 |
| 163 | LID, BELT COVER | 760539 |

CRAFTSMAN 33" 12.5HP SNOW THROWER 536.881121

DRIVE COMPONENTS

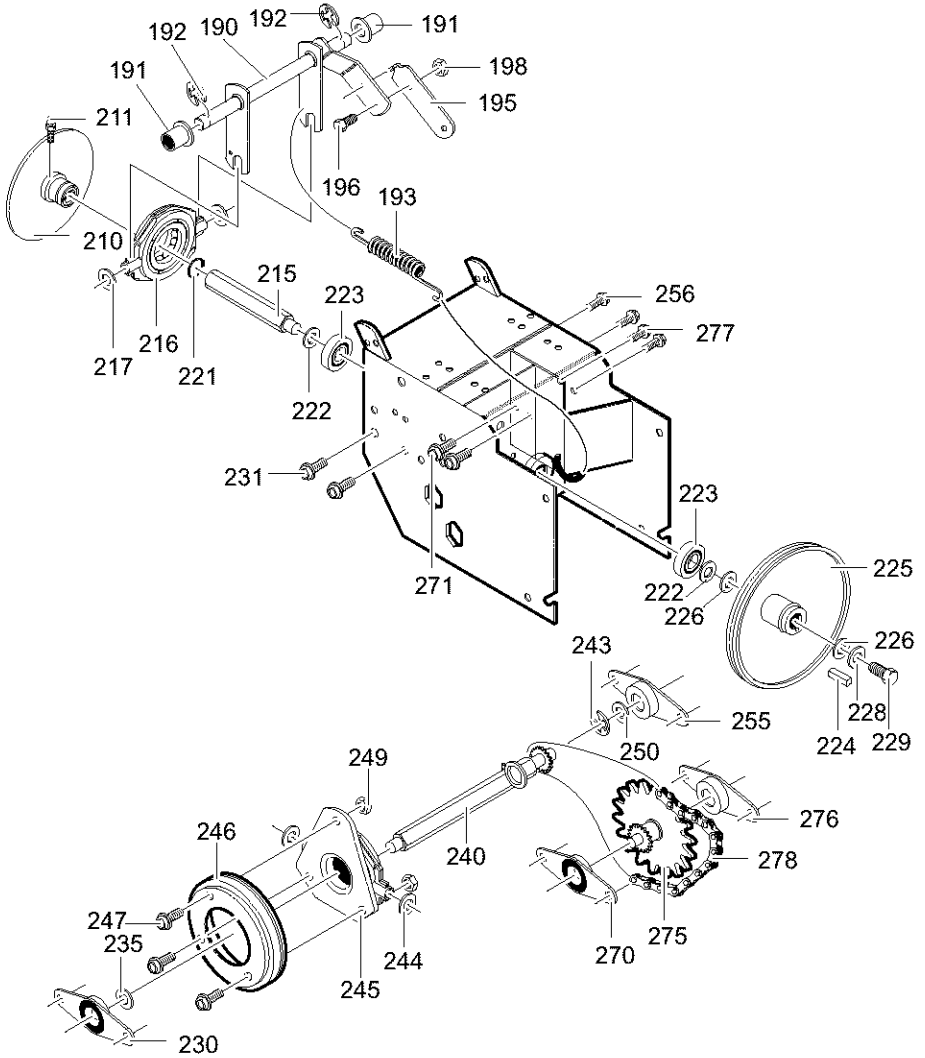

313995 REV P

**CRAFTSMAN 33" 12.5HP SNOW THROWER 536.881121
DRIVE COMPONENTS**

| Key No. | Description | Part No. |
|----------------|-----------------------------|-----------------|
| 190 | LEVER, ASSY TRACTION CLUTCH | 761820 |
| 191 | BEARING, FLANGE | 53703 |
| 192 | RING, RET E | 20864 |
| 193 | SPRING, RETURN | 53818 |
| 195 | LEVER, SPRING | 579937 |
| 196 | SCREW, 1/4-20X .63 | 11871 |
| 198 | NUT, 1/4-20 | 73826 |
| 210 | DISC, ASSY | 583163-853 |
| 211 | ZERK, GREASE | 583206 |
| 215 | SHAFT, HEX TRACTION | 583155 |
| 216 | BEARING, TRUNION | 85501 |
| 217 | FLATWASHER | 71074 |
| 221 | RING, RETEX | 73811 |
| 222 | FLATWASHER | 580969 |
| 223 | BEARING, BALL | 43846 |
| 224 | KEY, SQUARE | 2001022 |
| 225 | PULLEY | 580961 |
| 226 | WASHER, WAVE | 580965 |
| 227 | FLATWASHER | 712123 |
| 228 | WASHER, SPLIT | 71059 |
| 229 | SCREW, 1/4-20X .75 | 1X176 |
| 230 | BEARING & RETAINER | 334163 |
| 231 | SCREW, 5/16-18X .50 | 780055 |
| 235 | WASHER | 579858 |
| 240 | HEX, ASSY | 579897 |
| 243 | RING, RETEX | 783002 |
| 244 | FLATWASHER | 71074 |
| 245 | BEARING, TRUNION | 337029 |
| 246 | WHEEL, ASSY FRICTION | 53830 |
| 247 | SCREW, 1/4-20X .63 | 11871 |
| 249 | NUT, 1/4-20 | 303008 |
| 250 | WASHER | 579858 |
| 255 | BEARING & RETAINER | 334163 |
| 256 | SCREW, 5/16-18X .50 | 780055 |
| 270 | BEARING & RETAINER | 334163 |
| 271 | SCREW, 5/16-18X .50 | 780055 |
| 275 | JACK, ASSY | 761789 |
| 276 | BEARING & RETAINER | 334163 |
| 277 | SCREW | 780055 |
| 278 | CHAIN ROLLER | 579867 |
| — | LINK, CHAIN MASTER | 760504 |

CRAFTSMAN 33" 12.5HP SNOW THROWER 536.881121

AUGER HOUSING ASSEMBLY

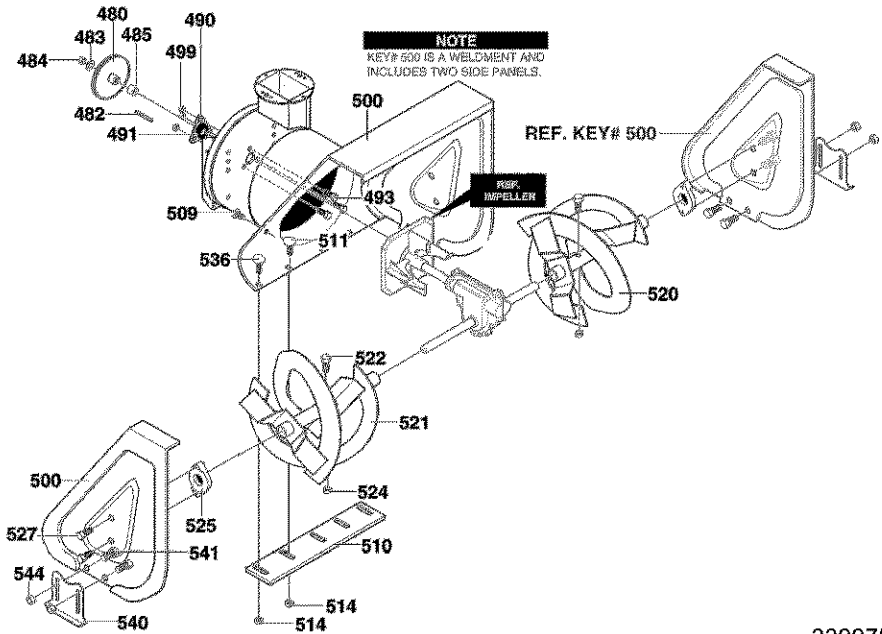

339975

| Key No. | Description | Part No. | Key No. | Description | Part No. |
|---------|----------------|------------|---------|---------------------|------------|
| 480 | PULLEY | 583146 | 511 | BOLT, 5/16-18 X .75 | 340720 |
| 482 | KEY, SQUARE | 2001022 | 514 | NUT, 5/16-18 | 710026 |
| 483 | WASHER, FLAT | 71074 | 520 | AUGER, ASSY, LH | 760317-853 |
| 484 | NUT, 1/2-20 | 712121 | 521 | AUGER, ASSY, RH | 760307-853 |
| 485 | SPACER, SLEEVE | 334514 | 522 | BOLT | 578647 |
| 490 | RETAINER, BRNG | 582960 | 524 | NUT, 5/16-18 | 71391 |
| 491 | BEARING, BALL | 43846 | 525 | BEARING | 53757 |
| 493 | SCREW | 313676 | 527 | SCREW | 70984 |
| 499 | NUT, 5/16-18 | 710026 | 536 | BOLT, 5/16-18X.75 | 340720 |
| 500 | HOUSING, ASSY | 761879-884 | 540 | SKID | 760192-853 |
| 509 | PLUG | 760040 | 541 | BOLT, CARRIAGE | 340720 |
| 510 | BLADE, SCRAPER | 760666-853 | 544 | NUT, 5/16-18 | 710026 |

CRAFTSMAN 33" 12.5HP SNOW THROWER 536.881121

GEAR CASE ASSEMBLY

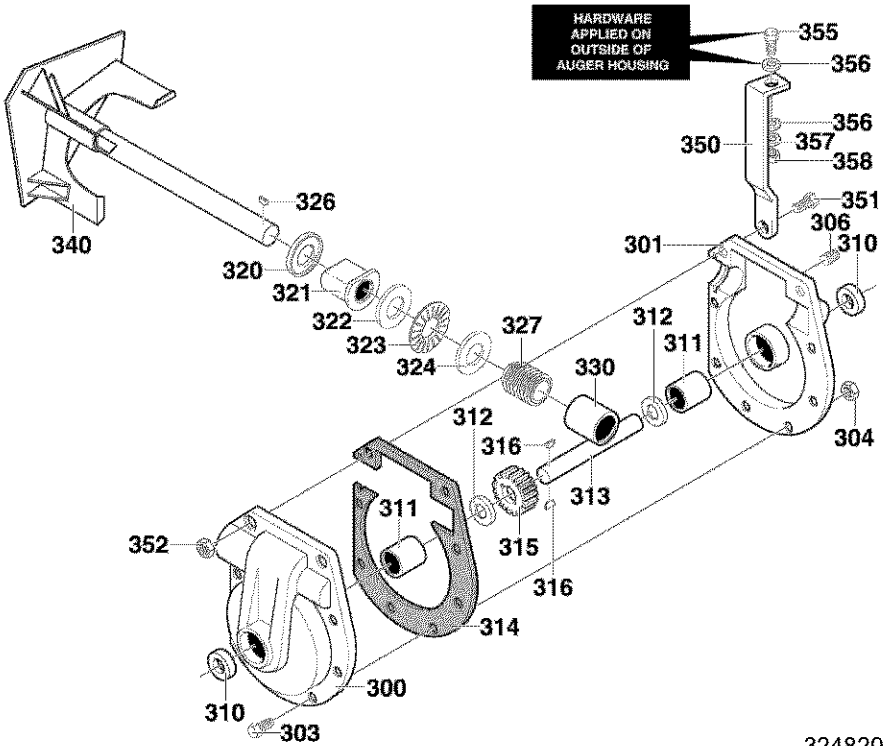

324820

| Key No. | Description | Part No. | Key No. | Description | Part No. |
|---------|-----------------|----------|---------|-----------------|------------|
| 300 | CASE, GEAR, RH | 896 | 323 | BEARING, ROLL | 50684 |
| 301 | CASE, GEAR, LH | 895 | 324 | WASHER, FLAT | 48275 |
| 303 | SCREW | 910828 | 326 | KEY | 50795 |
| 304 | NUT, 5/16-24 | 71100 | 327 | WORM GEAR | 53732 |
| 306 | PIPE PLUG | 53749 | 330 | BEARING, SLEEVE | 53731 |
| 310 | SEAL, OIL | 780151 | 340 | IMPELLER | 761609-853 |
| 311 | BEARING, SLEEVE | 53743 | 350 | BRACE | 5524 |
| 312 | WASHER, FLAT | 53748 | 351 | SCREW | 1441 |
| 313 | SHAFT, AUGER | 760411 | 352 | NUT, 5/16-24 | 71100 |
| 314 | GASKET | 897 | 355 | SCREW | 302636 |
| 315 | WORM GEAR | 53730 | 356 | WASHER, FLAT | 71071 |
| 316 | KEY, WOODRUFF | 73905 | 357 | WASHER | 71060 |
| 320 | RING, QUAD | 53737 | 358 | NUT | 71037 |
| 321 | BEARING, FL | 583126 | * | 10oz LUBRIPLATE | 333431 |
| 322 | WASHER, FLAT | 48275 | | | |

CRAFTSMAN 33" 12.5HP SNOW THROWER 536.881121
DISCHARGE CHUTE ASSEMBLY

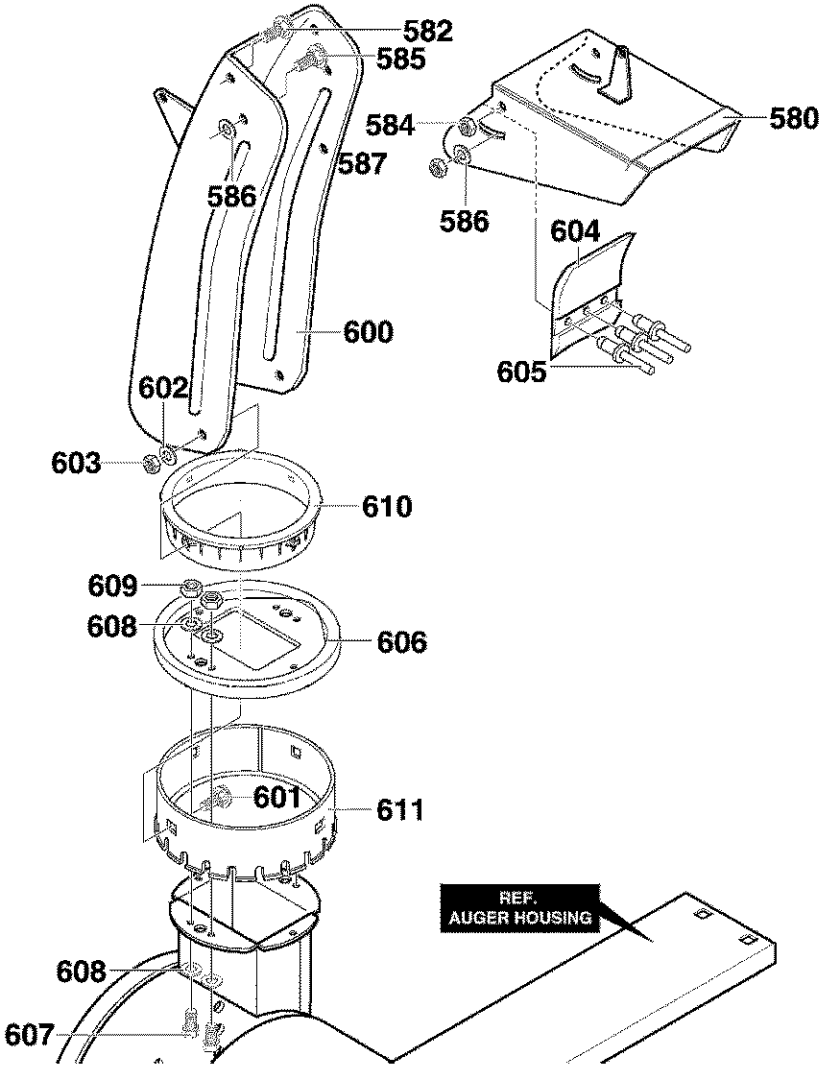

**CRAFTSMAN 33" 12.5HP SNOW THROWER 536.881121
DISCHARGE CHUTE ASSEMBLY**

| Key No. | Description | Part No. |
|----------------|------------------------|-----------------|
| 580 | ASSY., UPPER CHUTE | 761168-853 |
| 582 | SCREW, 5/16-18X.75 | 578088 |
| 584 | NUT, 5/16-18 HEX | 71038 |
| 585 | SCREW, 5/16-18X.75 | 578088 |
| 586 | WASHER | 6711 |
| 587 | NUT, 5/16-18 HEX NYL | 71038 |
| 600 | LOWER CHUTE ASSEMBLY | 761169-853 |
| 601 | BOLT, 5/16-18X1.00 | 586280 |
| 602 | FLATWASHER | 71071 |
| 603 | NUT, 5/16-18 | 71038 |
| 604 | FLAP | 762322 |
| 605 | RIVET | 760987 |
| 606 | COLLAR, CHUTE | 585214-853 |
| 607 | SCREW, 1/4-20X .75 | 302628 |
| 608 | FLATWASHER | 71067 |
| 609 | NUT, 1/4-20 HEX NYLOCK | 780029 |
| 610 | RETAINER, RING INNER | 337227 |
| 611 | RETAINER, RING OUTER | 585193 |

CRAFTSMAN 33" 12.5HP SNOW THROWER 536.881121

HANDLE ASSEMBLY

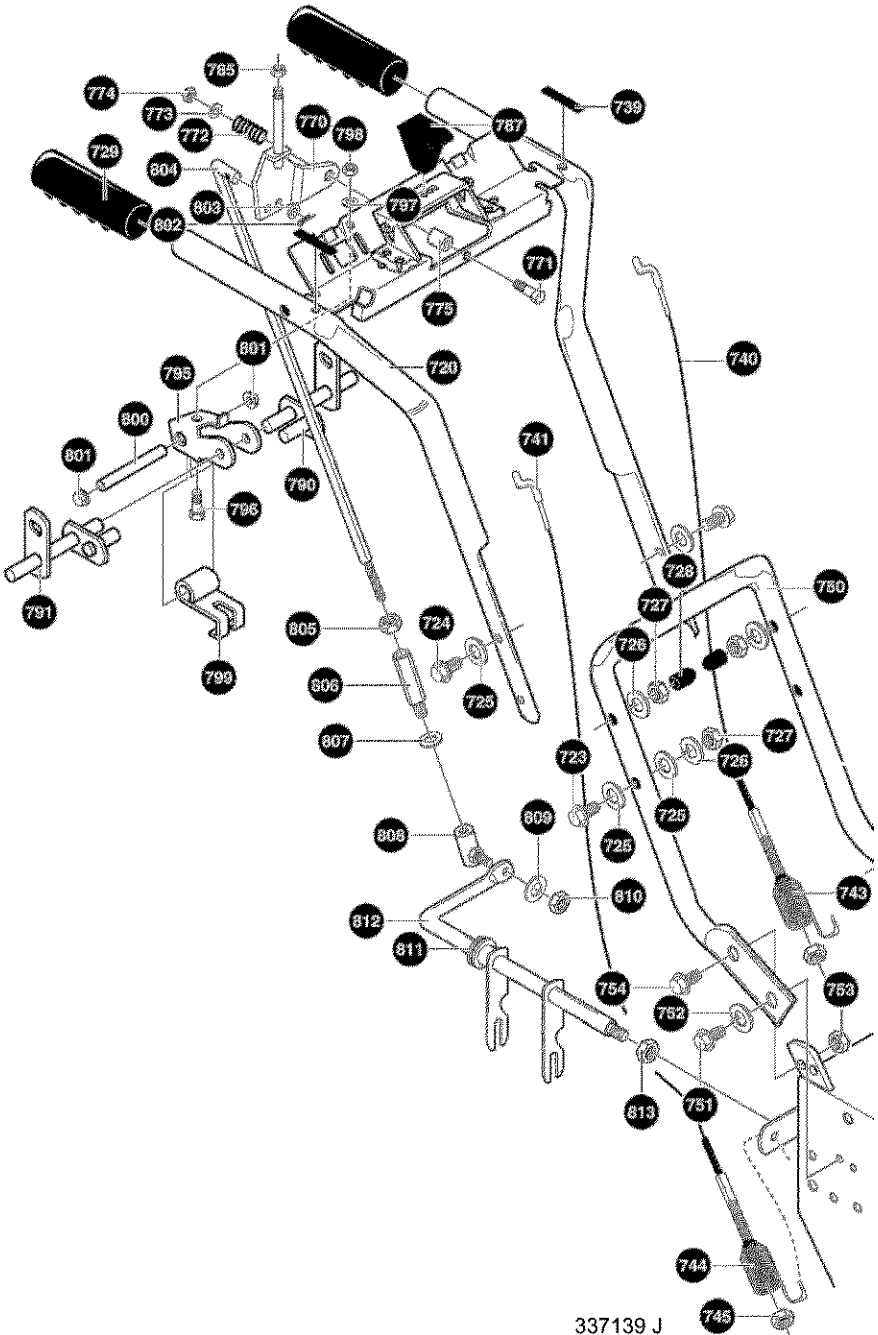

337139 J

CRAFTSMAN 33" 12.5HP SNOW THROWER 536.881121

HANDLE ASSEMBLY

| Key No. | Description | Part No. | Key No. | Description | Part No. |
|---------|----------------------|----------|---------|--------------------|----------|
| 720 | ASSEMBLY, HANDLE | 579264 | 775 | SPACER | 579183 |
| 723 | SCREW, 3/8-16X2.00 | 71007 | 785 | NUT, 1/4-20 HEX | 71034 |
| 724 | SCREW, 3/8-16X3.00 | 7288 | 787 | KNOB, SHIFT 1/420 | 585522 |
| 725 | WASHER, FLAT | 71072 | 790 | ROD, ASSY LH | 578926 |
| 726 | WASHER | 71062 | 791 | ROD, ASSY RH | 578924 |
| 727 | NUT, 3/8-16 REGHEX | 71044 | 795 | BRACKET, CAM | 579002 |
| 728 | STOP, PLASTIC | 7289 | 796 | SCREW, 5/16-18X.75 | 313676 |
| 729 | GRIP, HANDLE | 50792 | 797 | WASHER, SPTLK | 71060 |
| 739 | BUMPER | 4049 | 798 | NUT, 5/16-18 HEX | 71037 |
| 740 | CABLE, CLUTCH | 1580 | 799 | CAM LOCK | 8417 |
| 741 | CABLE, AUG CLUTCH | 761591 | 800 | PIN, SPRING PIVOT | 584673 |
| 743 | TENSION SPRING | 579869 | 801 | NUT, PUSH ON | 73664 |
| 744 | SPRING, CLUTCH | 1673 | 802 | PIN, COTTER | 71081 |
| 745 | NUT, 1/4-20 HEX | 780029 | 803 | FLATWASHER | 71071 |
| 750 | HANDLE, LOWER | 5543-853 | 804 | ROD, CONTROL | 581079 |
| 751 | SCREW, 5/16-18 X .75 | 70984 | 805 | NUT, 5/16-24 HEX | 71042 |
| 752 | WASHER, SPTLK | 71060 | 806 | ADAPTOR, SPEED | 6352 |
| 753 | NUT, 5/16-18 | 71391 | 807 | WASHER | 71060 |
| 754 | SCREW, 5/16-18 X .75 | 70984 | 808 | JOINT, STEEL BALL | 50782 |
| 770 | BRACKET, SHIFT | 581964 | 809 | WASHER | 71060 |
| 771 | SCREW, 3/8-16X3.00 | 7288 | 810 | NUT, 5/16-24 HEX | 71042 |
| 772 | SPRING | 50786 | 811 | BEARING, FL | 579944 |
| 773 | WASHER, FLAT | 71072 | 812 | ROD, YOKE | 337436 |
| 774 | NUT, 3/8-16 HEX | 71046 | 813 | NUT, 38-16 | 71111 |

CRAFTSMAN 33" 12.5HP SNOW THROWER 536.881121

WHEEL ASSEMBLY

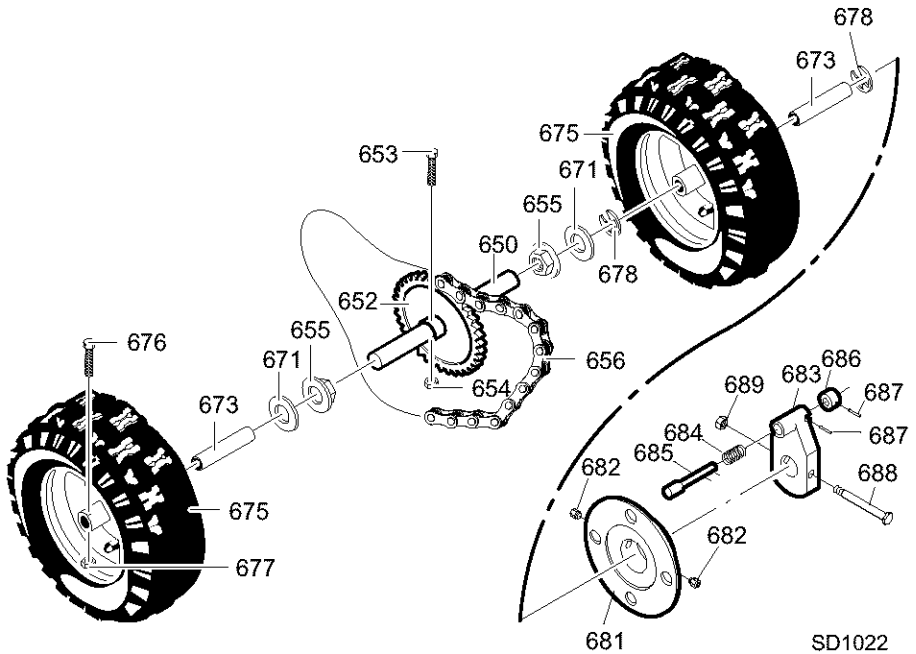

| Key No. | Description | Part No. |
|---------|------------------------|-------------|
| 650 | SHAFT, AXLE | 583017 |
| 652 | SPRKT & HUB | 583007 |
| 653 | SCREW, 1/4-20X2.25 | 73839 |
| 654 | NUT, 1/4-20 HEX NYLOCK | 780029 |
| 655 | BRNG, FL | 581730 |
| 656 | CHAIN, ROLLER | 583013 |
| 671 | FLATWASHER | 712120 |
| 673 | BUSHING, WHEEL | 585591 |
| 675 | TIRE & RIM | 584633 |
| 676 | SCREW, 1/4-20X1.75 | 577015 |
| 677 | NUT, 1/4-20 HEX NYLOCK | 780029 |
| 678 | RING, RET | 239 |
| 681 | DISC, WHEEL | 1501032-853 |
| 682 | SCREW | 2001066 |
| 683 | HUB, WHEEL LOCK | 1501031-853 |
| 684 | SPRING, COMPRESSION | 164X34 |
| 685 | PIN, LOCK | 1501033 |
| 686 | KNOB | 1501034 |
| 687 | PIN | 032X78 |
| 688 | SCREW | 73839 |
| 689 | NUT | 780029 |

**CRAFTSMAN 33" 12.5HP SNOW THROWER 536.881121
CONTROL PANEL ASSEMBLY**

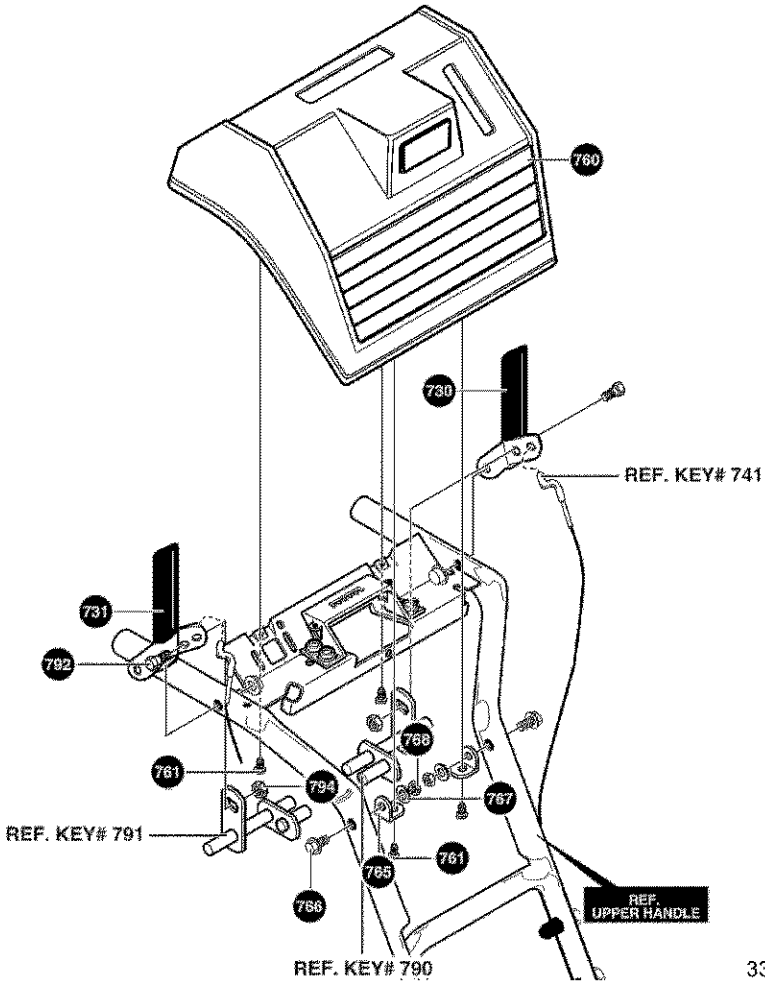

337139 J

| Key No. | Description | Part No. |
|---------|-----------------------|------------|
| 730 | CLUTCH HANDLE LH | 578992 |
| 731 | CLUTCH HANDLE RH | 578993 |
| 760 | PANEL, CONTROL | 579039 |
| 761 | SCREW, 10 X .62 | 316042 |
| 765 | BRACKET, PANEL | 578866-853 |
| 766 | SCREW, 5/16-18 X 1.75 | 302900 |
| 767 | WASHER, HVSP TLK | 71060 |
| 768 | NUT, 5/16-18 | 71037 |
| 792 | BOLT, 1/4-20 X .50 | 905531 |
| 794 | NUT, 1/4-20 | 908913 |

CRAFTSMAN 33" 12.5HP SNOW THROWER 536.881121

CHUTE CONTROL ROD ASSEMBLY

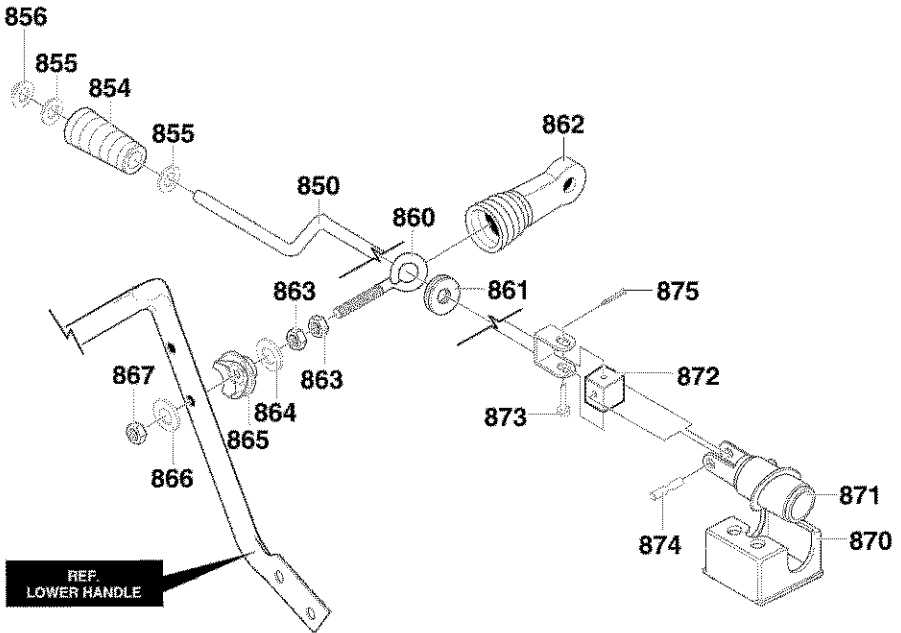

334215

| Key No. | Description | Part No. |
|---------|---------------------------|----------|
| 850 | CRANK, ASSY CHUTE | 585426 |
| 854 | HANDLE, CHUTE CRANK | 307399 |
| 855 | FLATWASHER | 309312 |
| 856 | E RING | 578159 |
| 860 | EYE BOLT 3/8-16X6.00 | 581618 |
| 861 | GROMMET, EYE BOLT | 148 |
| 862 | BOOT | 308145 |
| 863 | NUT, 3/8-16 HEXJAM | 71045 |
| 864 | FLATWASHER | 71072 |
| 865 | ADAPTER, BOOT TO HANDLE | 309344 |
| 866 | FLATWASHER | 71072 |
| 867 | NUT, 3/8-16 HEXNYL | 71046 |
| 870 | BRACKET, WORM MTG | 585195 |
| 871 | WORM, GEAR CHUTE ROTATION | 585196 |
| 872 | BLOCK, UNIVERSAL PIVOT | 578063 |
| 873 | CLEVIS PIN | 578309 |
| 874 | PIN, UNIVERSAL JOINT | 578060 |
| 875 | COTTER PIN | 579493 |

CRAFTSMAN 33" 12.5HP SNOW THROWER 536.881121 HEADLIGHT

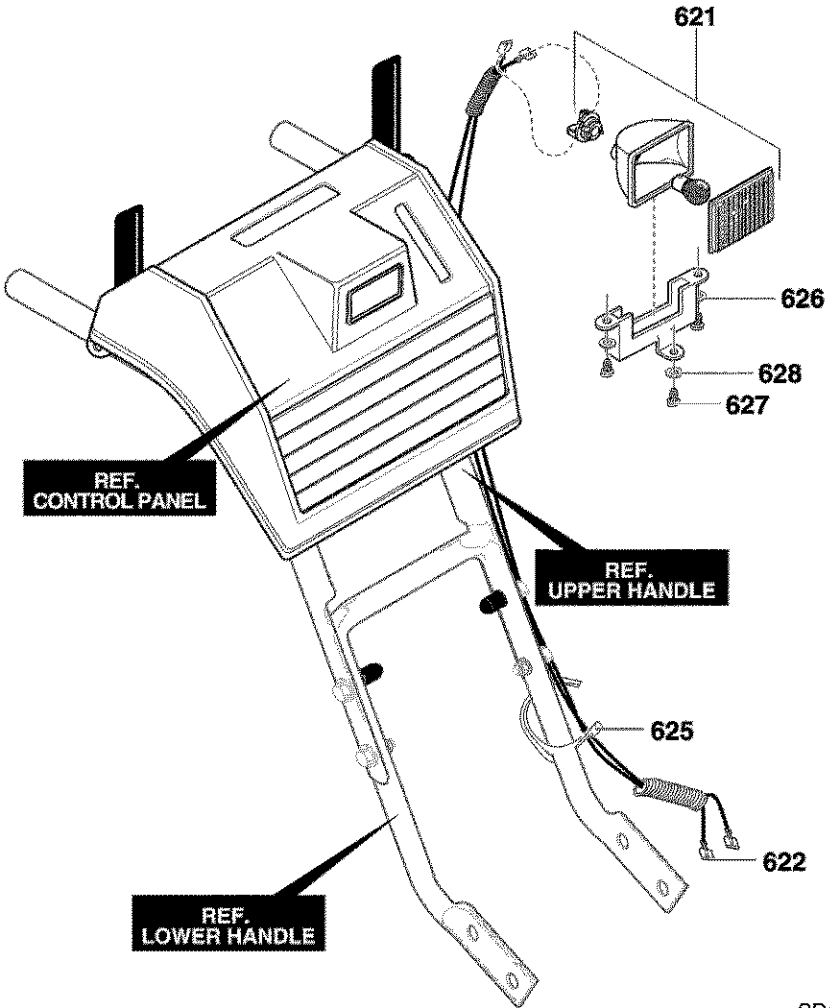

SD1029

| Key No. | Description | Part No. |
|---------|-------------------|----------|
| 621 | LIGHT, HALOGEN | 762343 |
| 622 | HARNES, HEADLIGHT | 1501036 |
| 625 | TIE, CABLE | 57444 |
| 626 | BRACKET | 578921 |
| 627 | SCREW #8 X .50 | 901696 |
| 628 | WASHER, FLAT | 901736 |

CRAFTSMAN 33" 12.5HP SNOW THROWER 536.881121

REMOTE CHUTE CONTROL ASSEMBLY

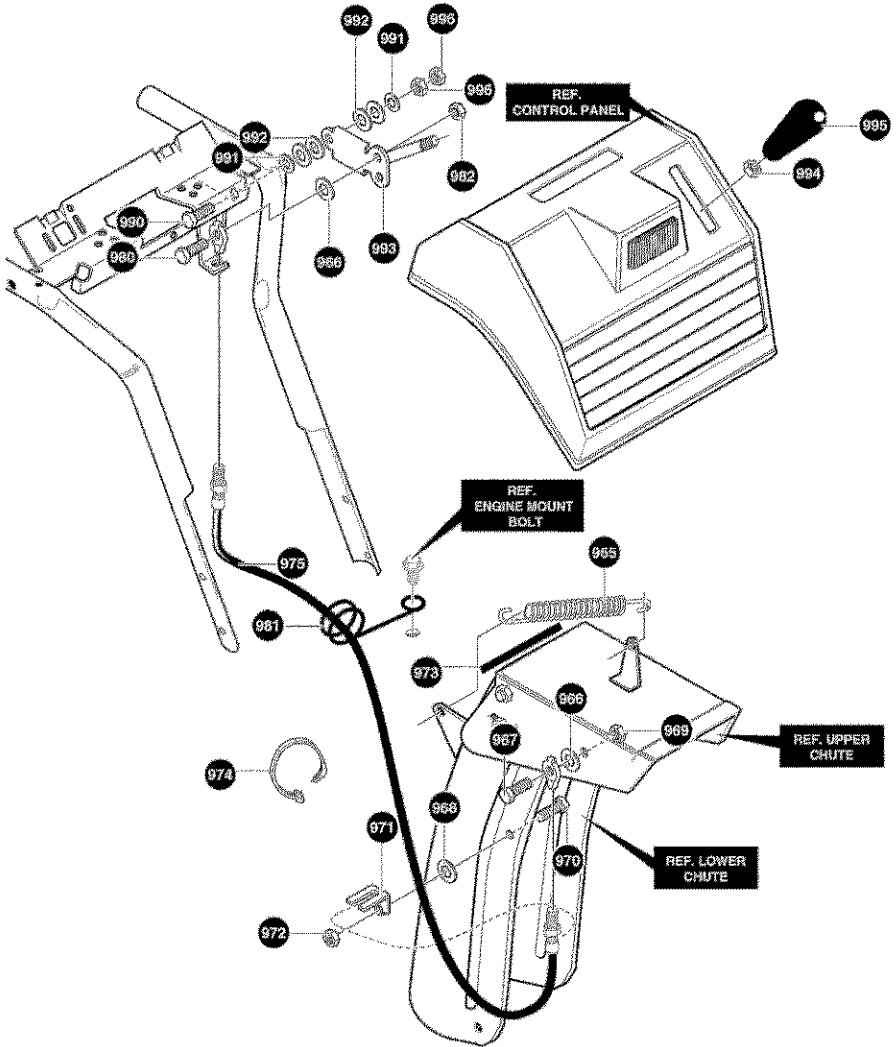

342858

CRAFTSMAN 33" 12.5HP SNOW THROWER 536.881121
REMOTE CHUTE CONTROL ASSEMBLY

| Key No. | Description | Part No. |
|----------------|----------------------------|-----------------|
| 965 | SPRING, TENSION RETURN | 318468 |
| 966 | WASHER, FLAT | 711666 |
| 967 | BOLT, 5/16-18 | 310088 |
| 968 | WASHER, FLAT | 73787 |
| 969 | NUT, 1/4-20 | 302635 |
| 970 | SCREW, 5/16-18 X .75 | 313676 |
| 971 | BRACKET, CABLE CHUTE | 780066 |
| 972 | NUT, 5/16-18 | 71391 |
| 973 | TRIM | 55021 |
| 974 | TIE, CABLE | 760113 |
| 975 | CABLE, CHUTE CONTROL | 761131 |
| 980 | BOLT, 5/16-18 | 310088 |
| 981 | WIRE FORM | 780220 |
| 982 | NUT, 1/4-10 | 302635 |
| 990 | SCREW, 3/8-16X1.75 | 4058 |
| 991 | WASHER, FLAT | 71072 |
| 992 | WASHER, SPRING | 4051 |
| 993 | HANDLE ASSY, SPEED CONTROL | 579040 |
| 994 | NUT, 3/8-16 REGHEX | 71044 |
| 995 | HANDLE, 3/8-16 MOLDED | 306689 |
| 996 | NUT, 3/8-16 HEX | 71046 |

**CRAFTSMAN 33" 12.5HP SNOW THROWER 536.881121
DRIFT CUTTER ASSEMBLY**

NOTE: THIS UNIT IS USED FOR REFERENCE
PURPOSE ONLY.

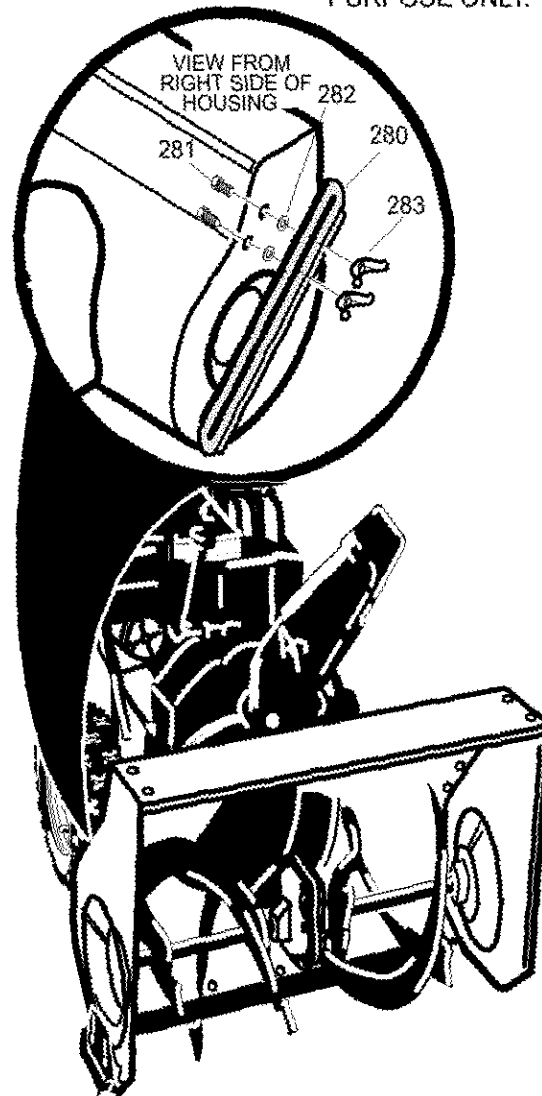

SD1027

| Key No. | Description | Part No. |
|---------|--------------------|------------|
| 280 | BAR, DRIFT CUTTER | 762348-853 |
| 281 | BOLT, 5/16-18X0.75 | 340720 |
| 282 | WASHER | 12021 |
| 283 | WINGNUT | 711604 |

CRAFTSMAN 4-CYCLE ENGINE MODEL NUMBER 143.011201

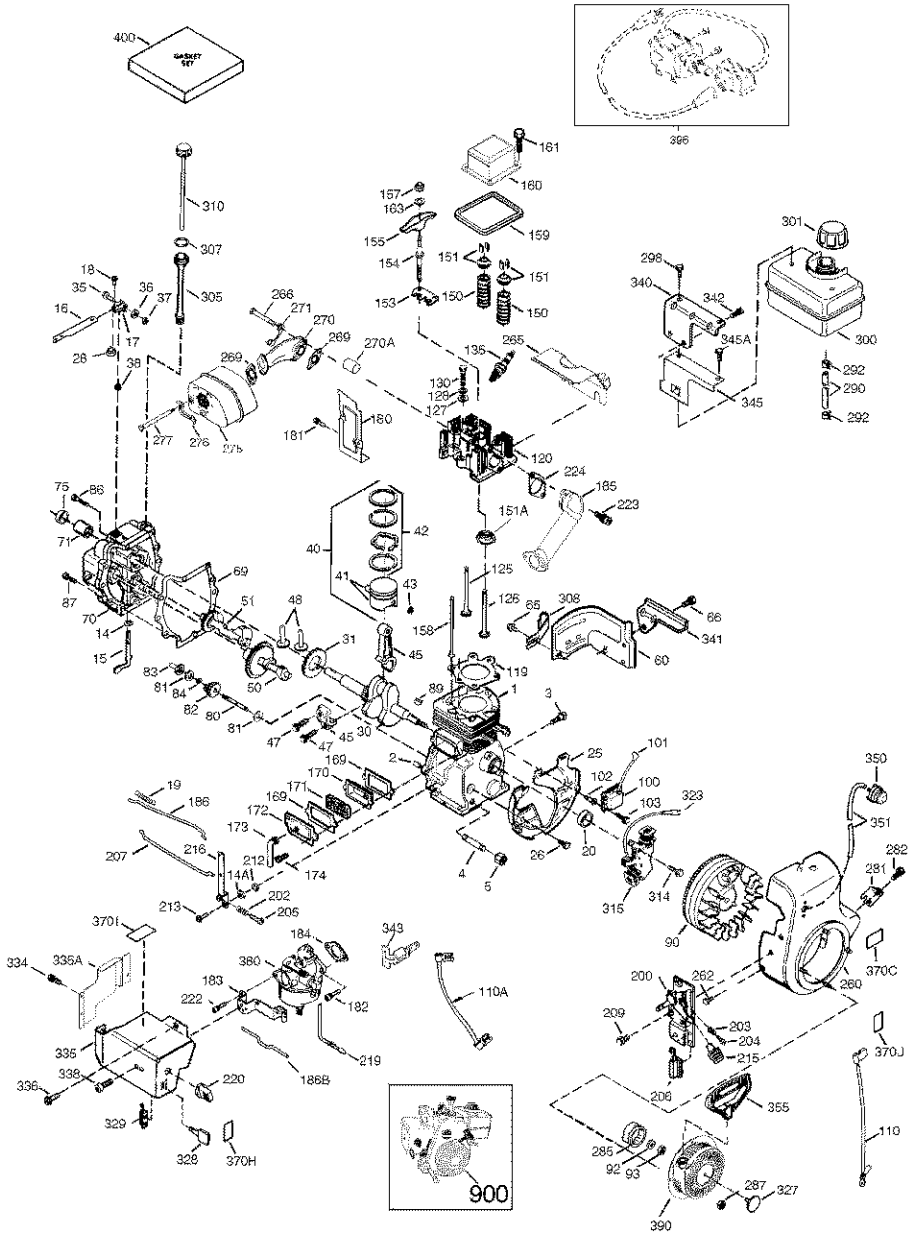

CRAFTSMAN 4-CYCLE ENGINE MODEL NUMBER 143.011201

| KEY NO. | PART NO. | DESCRIPTION | KEY NO. | PART NO. | DESCRIPTION |
|---------|----------|--|---------|----------|--|
| | 0 | RPM High 3550 to 3850 | 41 | 35775A | Piston & Pin Ass'y (.020" OS) (Incl. 43) |
| | 0 | RPM Low 1850 to 2150 | 42 | 35779 | Ring Set (Std.) |
| 1 | 37083 | Cylinder (Incl. 2, 20 & 80) | 42 | 35780 | Ring Set (.010" OS) |
| 2 | 27652 | Dowel Pin | 42 | 35781 | Ring Set (.020" OS) |
| 3 | 650820 | Screw, 1/4-20 x 1/2" | 43 | 35772 | Piston Pin Retaining Ring |
| 4 | 31857 | Oil Drain Extension | 45 | 36898 | Connecting Rod Ass'y (Incl. 47) |
| 5 | 30969 | Extension Ca | 47 | 651033 | Connecting Rod Bolt |
| 14 | 28277 | Washer | 48 | 35313 | Valve Lifter |
| 14A | 651057 | Washer | 50 | 35682A | Camshaft (MCR) |
| 15 | 35685 | Governor Rod (Incl. 14 & 38) | 51 | 35315A | Counterbalance Weight |
| 16 | 35686 | Governor Lever | 60 | 35316A | Blower Housing Extension |
| 17 | 29916 | Governor Lever Clam | 65 | 30200 | Screw, 10-24 x 9/16" |
| 18 | 651028 | Screw, Torx T-15 | 66 | 650990 | Screw, Torx T-30 |
| 19 | 35688 | Extension Spring | 69 | 35683 | Cylinder Cover Gasket |
| 20 | 35319 | Oil Seal | 70 | 35684A | Cylinder Cover (Incl. 14,15, 38, 71, 75) |
| 25 | 36460 | Blower Housing Baffle | 71 | 35377 | Crankshaft Bushing |
| 26 | 650561 | Screw, 1/4-20 x 5/8" | 75 | 35319 | Oil Seal |
| 28 | 30322 | Lock Nut, 10-32 | 80 | 35751 | Governor Shaft |
| 30 | 37240 | Crankshaft | 81 | 35479A | Washer |
| 31 | 35327 | Counterbalance Gear | 82 | 35321 | Governor Gear Ass'y |
| 35 | 29826 | Screw, 10-32 x 3/4" | 83 | 35322 | Governor Spool |
| 36 | 29918 | Lock Washer | 84 | 29193 | Retaining Ring |
| 37 | 29216 | Lock Nut, 10-32 | 86 | 650833 | Screw, 1/4-20 x 1-3/16" |
| 38 | 29642 | Retaining Ring | 87 | 650832 | Screw, 1/4-20 x 1-11/16" |
| 40 | 35776A | Piston, Pin & Ring Set (Std.) | 89 | 32589 | Flywheel Key |
| 40 | 35777A | Piston, Pin & Ring Set (.010" OS) | 90 | 611093 | Flywheel (W/Ring Gear) |
| 40 | 35778A | Piston, Pin & Ring Set (.020" OS) | 92 | 650880 | Lock Washer |
| 41 | 35773A | Piston & Pin Ass'y (Std.) (Incl. 43) | 93 | 650881 | Flywheel Nut |
| 41 | 35774A | Piston & Pin Ass'y (.010" OS) (Incl. 43) | 100 | 35135 | Solid State Ignition |
| | | | 101 | 610118 | Spark Plug Cover |

CRAFTSMAN 4-CYCLE ENGINE MODEL NUMBER 143.011201

| | | | | | |
|------|---------|----------------------------|------|--------|--|
| 102 | 651024 | Solid State Mounting Stud | 184 | 33263 | Carburetor To Intake Pipe Gasket |
| 103 | 651007 | Screw, Torx T-15 | | | |
| 110 | 35187 | Ground Wire | 185 | 37085 | Intake Pipe |
| 110A | 36874 | Ground Wire | 186 | 35691 | Governor Link |
| 119 | 36932 | Cylinder Head Gasket | 186B | 36653 | Choke Spring |
| 120 | 37491 | Cylinder Head (Incl. 151A) | 200 | 35702 | Control Bracket (Incl. 203, 204 & 206) |
| 125 | 36934 | Exhaust Valve (Std.) | 202 | 36482 | Compression Spring |
| 125 | 36936 | Exhaust Valve (1/32" OS) | 203 | 31342 | Compression Spring |
| 126 | 36935 | Intake Valve (Std.) | 204 | 651029 | Screw, Torx T-10 |
| 127 | 650691 | Washer | 205 | 651019 | Screw, Torx T-10 |
| 128 | 650690 | Belleville Washer | 206 | 610973 | Terminal |
| 130 | 650697A | Screw, 5/16-18 x 2-1/2" | 207 | 35692 | Throttle Link |
| 135 | 34645 | Spark Plug (RN4C) | 209 | 650821 | Screw, 10-32 x 1/2" |
| 150 | 33507 | Valve Spring | 212 | 30773A | Bushing |
| 151 | 33508 | Valve Spring Keeper | 213 | 650930 | Screw, 10-32 x 5/8" |
| 151A | 35862 | Intake Valve Seal | 215 | 35438 | Control Knob |
| 153 | 35949 | Push Rod Guide | 216 | 35679 | R.P.M. Adjusting Lever |
| 154 | 650945 | Rocker Arm Stud | 219 | 35689 | Choke Rod |
| 155 | 35950 | Rocker Arm | 220 | 35440 | Choke Knob |
| 157 | 650947 | Jam Nut | 222 | 28820 | Screw, 10-32 x 1/2" |
| 158 | 35466 | Push Rod | 223 | 650971 | Screw, Torx T-30 |
| 159 | 35952 | Rocker Arm Cover Gasket | 224 | 33515A | Intake Pipe Gasket |
| 160 | 35953A | Rocker Arm Housing | 260 | 35694 | Blower Housing |
| 161 | 30063 | Screw, Torx T-30 | 262 | 29747B | Screw, Torx T-40 |
| 163 | 650890 | Lock Washer | 265 | 37086 | Cylinder Head Cover |
| 169 | 27896A | Valve Cover Gasket | 266 | 650876 | Screw, 5/16-18 x 1-1/4" |
| 170 | 28423 | Breather Body | 269 | 35762 | Exhaust Gasket |
| 171 | 28424 | Breather Element | 270 | 35870 | Manifold |
| 172 | 28425 | Valve Cover | 270A | 35829A | Exhaust Port Liner |
| 173 | 35350 | Breather Tube | 271 | 35293 | Locking Plate (Manifold) |
| 174 | 650128 | Screw, 10-24 x 1/2" | 275 | 36542 | Muffler |
| 180 | 35954 | Blower Housing Extension | 276 | 35348 | Locking Plate |
| 181 | 30200 | Lock Nut, 10-32 | 277 | 650877 | Screw, 5/16-18 x 4-1/2" |
| 182 | 650517 | Screw, Torx T-30 | 281 | 33013 | Starter Bubble Cover |
| 183 | 34583A | Choke Bracket | | | |

CRAFTSMAN 4-CYCLE ENGINE MODEL NUMBER 143.011201

| | | | | | |
|------|--------|--|------|---------|--|
| 282 | 650760 | Screw, 8-32 x 3/8" | 342 | 792028 | Screw, 5/16-18 x 7/8" |
| 285 | 35985B | Starter Cu | 343 | 35079 | Key Switch Bracket |
| 287 | 29752 | Nut & Lock Washer | 345 | 35699 | Heat Baffle |
| 290 | 30962 | Fuel Line | 345A | 650876 | Screw, 5/16-18 x 1-9/32" |
| 292 | 26460 | Fuel Line Clamp | 350 | 570682A | Primer Ass'y |
| 298 | 650665 | Screw, 1/4-15 x 3/4" | 351 | 32180C | Primer Line |
| 300 | 34156A | Fuel Tank (Incl. 292 & 301) | 355 | 590574 | Starter Handle |
| 301 | 35355 | Fuel Ca | 370C | 36501 | Primer Decal |
| 305 | 35574 | Oil Fill Tube | 370H | 34589 | Choke Decal |
| 307 | 35499 | "O" Ring | 370I | 35878 | Warning Decal |
| 308 | 35539 | Fill Tube Cli | 370J | 35703 | Throttle Decal |
| 310 | 35700 | Dipstick | 380 | 640105 | Carburetor (Incl. 184) |
| 314 | 650873 | Screw, 1/4-20 x 3/4" | 390 | 590749 | Rewind Starter (Note: This engine could have been built with 590733 starter.) |
| 315 | 611111 | Alternator Coil (18 Watt) (Incl. 323) | 396 | 33329E | Electric Starter Motor (Optional) |
| 323 | 611118 | Terminal | 400 | 36947A | Gasket Set (Incl. Items Marked PK in Notes) Incl. part #'s 27896A (2), 33263 (1), 33515A (1), 35317 (1), 35683 (1), 35762 (2), 35952 (1), 36333 (1), 36352 (1), 36358 (1), 36832 (1), 36930 (1), 36932 (1), 36942 (1) |
| 327 | 35392 | Starter Plug | 900 | 0 | Replacement Engine None |
| 328 | 35593 | Ignition Keys | 900 | 0 | Replacement Short Block, 758215 orderfrom 71- 1 - 999 |
| 329 | 610973 | Terminal | | | |
| 334 | 650257 | Screw, 8-32 x 5/16" | | | |
| 335 | 37103 | Carburetor Cover (Front) | | | |
| 335A | 37087 | Carburetor Cover | | | |
| 336 | 650765 | Screw, 10-32 x 1/2" | | | |
| 338 | 650821 | Screw, 10-32 x 1/2" | | | |
| 340 | 35696 | Fuel Tank Bracket | | | |
| 341 | 35697 | Fuel Tank Bracket | | | |

CRAFTSMAN 4-CYCLE ENGINE MODEL NUMBER 143.011201

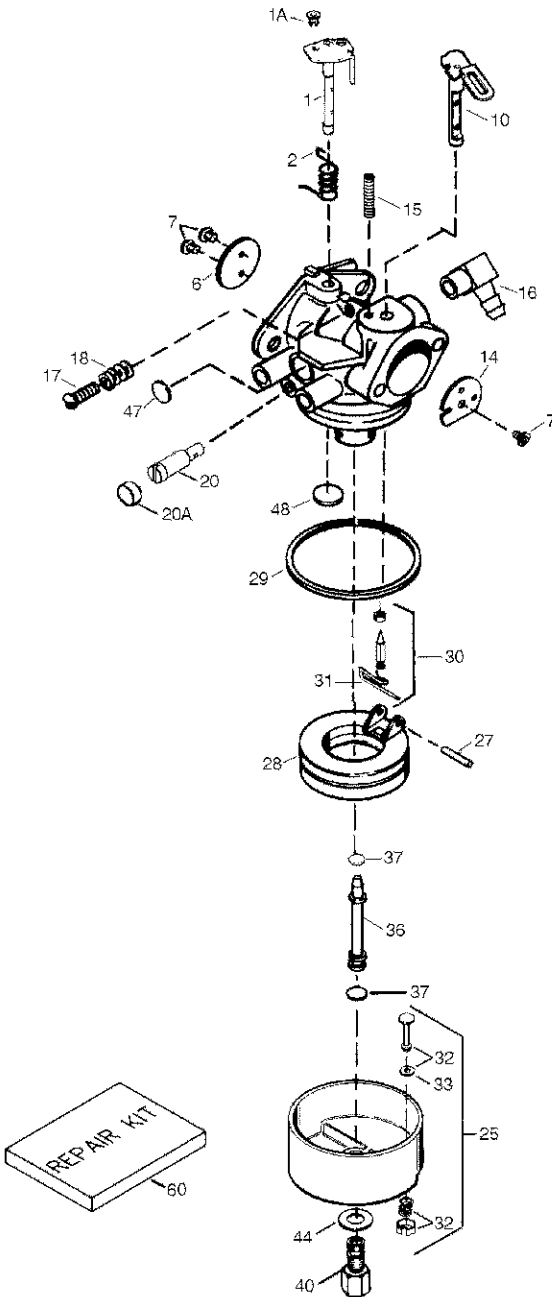

CRAFTSMAN 4-CYCLE ENGINE MODEL NUMBER 143.011201

| KEY NO. | PART NO. | DESCRIPTION |
|---------|----------|---|
| 0 | 640105 | Carburetor (Incl. 184 of Engine Parts List) |
| 1 | 632787 | Throttle Shaft & Lever Assembly |
| 1A | 36288 | Bushing |
| 2 | 631970 | Throttle Return Spring |
| 6 | 640107 | Throttle Shutter |
| 7 | 650506 | Shutter Screw |
| 10 | 632513 | Choke Shaft & Lever Assembly |
| 14 | 632429A | Choke Shutter |
| 15 | 630735 | Choke Positioning Spring |
| 16 | 632527 | Fuel Fitting |
| 17 | 651025 | Throttle Crack Screw/Idle Speed Screw |
| 18 | 630766 | Tension Spring |
| 20 | 640016 | Idle Restrictor Screw |
| 20A | 640053 | Idle Restrictor Screw Cap |
| 25 | 632594A | Float Bowl Assembly (Incl. 32 & 33) |
| 27 | 631024 | Float Shaft |
| 28 | 632019 | Float |
| 29 | 631028 | Float Bowl "O" Ring |
| 30 | 631021 | Inlet Needle, Seat, & Clip (Incl. 31) |
| 31 | 631022 | Spring Clip |
| 32 | 27136 | Bowl Drain Assembly |
| 33 | 27554 | Drain Plunger Gasket |
| 36 | 640005 | Main Nozzle Tube |
| 37 | 632547 | O Ring, Main Nozzle Tube |
| 40 | 640106 | High Speed Bowl Nut |
| 44 | 27110A | Bowl Nut Washer |
| 47 | 630748 | Welch Plug, Idle Mixture Well |
| 48 | 631027 | Welch Plug, Atmospheric Vent |
| 60 | 632760 | Repair kit (Incl. Items Marked PK in Notes) |

CRAFTSMAN 4-CYCLE ENGINE MODEL NUMBER 143.011201

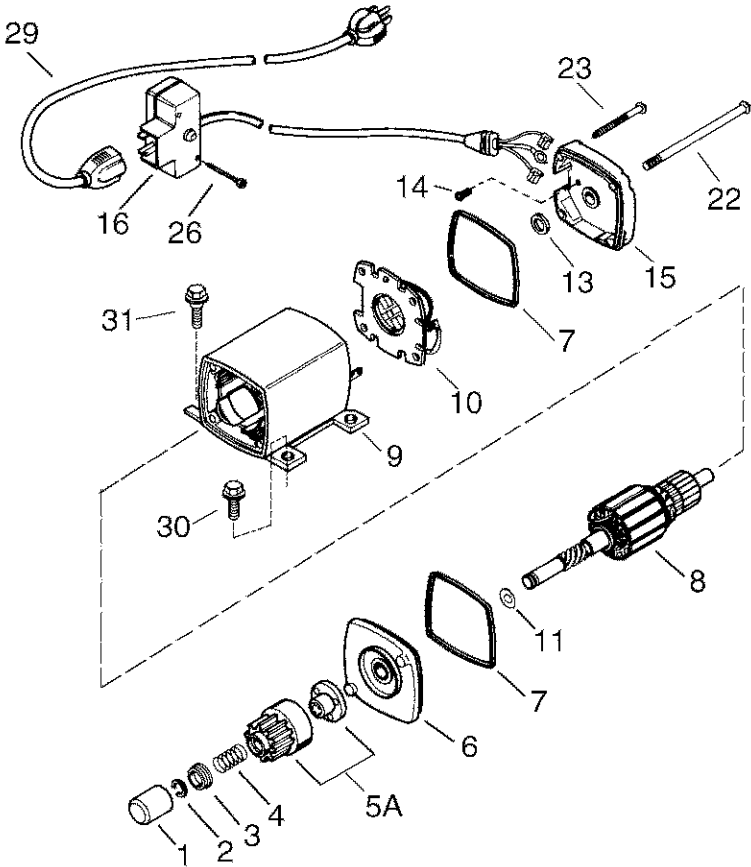

CRAFTSMAN 4-CYCLE ENGINE MODEL NUMBER 143.011201

| KEY NO. | PART NO. | DESCRIPTION |
|----------------|-----------------|-------------------------------------|
| 0 | 37105 | Electric Starter (110 Volt) |
| 1 | 33451 | Dust Cover |
| 2 | 33842 | Retainer Ring |
| 3 | 33430 | Spring Retainer |
| 4 | 33431 | Anti-drift Spring |
| 5A | 37050 | Gear & Nut (Incl. 2) |
| 6 | 35449 | Drive End Cap Ass'y. (Incl. 7) |
| 7 | 35450 | "O" Ring |
| 8 | 35915 | Armature |
| 9 | 35451B | Housing Ass'y. |
| 10 | 35452A | Brush Card Ass'y. |
| 11 | 35911 | Thrust Washer |
| 13 | 590500 | Thrust Washer |
| 14 | 33441 | Ground Screw |
| 15 | 35453 | Commutator End Cap Ass'y. (Incl. 7) |
| 16 | 35454 | Switch Box Ass'y. |
| 22 | 35455 | Case Bolt |
| 23 | 35456 | Ground Screw |
| 26 | 650819 | Screw, 6-32 X 2-1/2" |
| 26 | 651032 | Screw, 12-16 x 5/8" |
| 29 | 32450B | Extension Cord (10'6") |
| 30 | 30063 | Screw, Torx T-30, 1/4-20 X 1/2" |
| 31 | 650820 | Screw, 1/4-20 X 1/2" |

CRAFTSMAN 4-CYCLE ENGINE MODEL NUMBER 143.011201

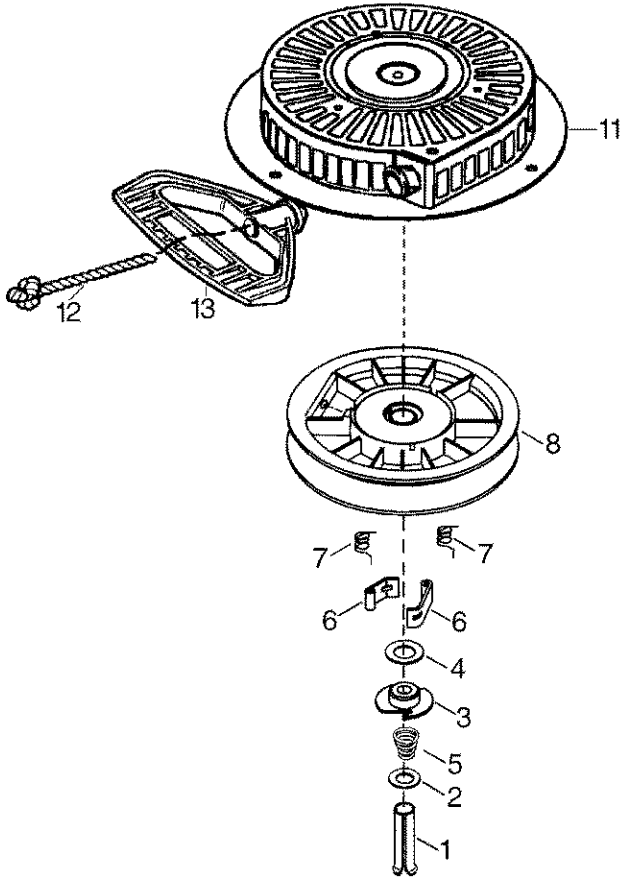

| KEY NO. | PART NO. | DESCRIPTION |
|---------|----------|--|
| 0 | 590749 | Rewind Starter |
| 1 | 590599A | Spring Pin |
| 2 | 590600 | Washer |
| 3 | 590679 | Retainer |
| 4 | 590601 | Washer |
| 5 | 590678 | Brake Spring |
| 6 | 590680 | Starter Dog |
| 7 | 590412 | Dog Spring |
| 8 | 590682 | Pulley & Rewind Spring Assy. |
| 11 | 590750 | Starter Housing Ass'y. |
| 12 | 590535 | Starter Rope (Length 98" x 9/64" dia.) |
| 13 | 590574 | Mitten Grip Handle (Not included with starter) |

For the repair or replacement parts you need delivered directly to your home
Call 7am–7pm, 7days a week

1-800-366-PART

(1-800-366-7278)

Para ordenar piezas con entrega a domicilio – 1-800-659-7084

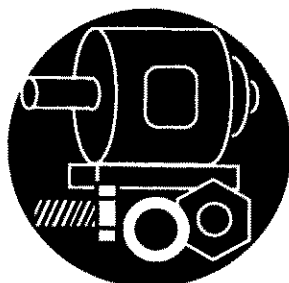

For in-house major brand repair service
Call 24 hours a day, 7days a week

1-800-4-REPAIR

(1-800-473-7247)

Para pedir servicio de reparación a domicilio– 1-800-676-5811



For the location of a Sears Parts and Repair Center in your area

Call 24 hours a day, 7days a week

1-800-488-1222



For information on purchasing a Sears Maintenance agreement or to inquire about an existing Agreement

Call 9am–5pm, Monday–Saturday

1-800-827-6655



When requesting service or ordering parts, always provide the following information:

- Product Type
- Part Number
- Model Number
- Part Description

SEARS
REPAIR SERVICES

America's Repair Specialists