

SEARS

operator's manual

MODEL NO. 143.026501

5.0 HORSEPOWER
6.5 CUBIC INCH(195 cc)
DISPLACEMENT

SOLID STATE IGNITION

CAUTION:

Read RULES for
Safe OPERATION
and INSTRUCTIONS
Carefully

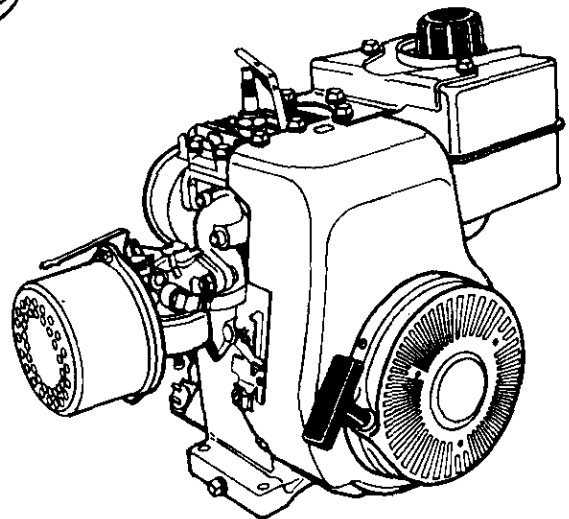
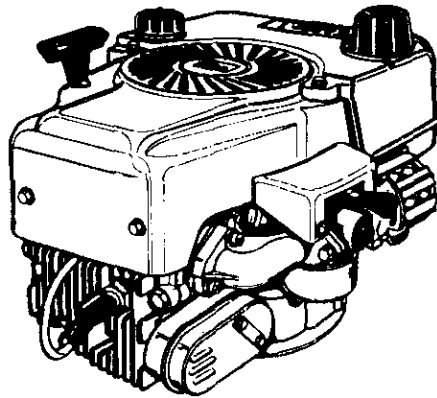

ENGINE

- Operating
- Maintenance
- Repair Parts



California Proposition 65

WARNING: The engine exhaust from this product contains chemicals known to the State of California to cause cancer, birth defects or other reproductive harm.

Sold by SEARS, ROEBUCK AND CO., CHICAGO, IL 60684 U.S.A.
and SEARS CANADA, INC., TORONTO, ONTARIO, CANADA

BEFORE STARTING (Continued)

- E. Remove OIL FILL PLUG and check oil level. If level is not up to "FULL" mark on DIPSTICK, add recommended oil, until it is. POUR SLOWLY.
Wipe DIPSTICK clean each time oil level is checked. DO NOT FILL ABOVE "FULL" MARK ON DIPSTICK.
- F. Replace OIL FILL PLUG and tighten securely.
See "MAINTENANCE" section for any future oil level and oil change instructions (see Page 2).



THE ALUMINUM COMPONENTS OF YOUR NEW ENGINE HAVE BEEN TREATED WITH A PRESERVATIVE INTENDED TO MAINTAIN THE APPEARANCE OF THE ENGINE. THE PRESERVATIVE WILL CURE DURING THE INITIAL USE OF THE ENGINE. A SMALL AMOUNT OF SMOKE MAY BE PRESENT DURING THE INITIAL USE OF THE PRODUCT AND SHOULD BE CONSIDERED NORMAL.

- ③ **FILL FUEL TANK** with gasoline as specified in the preceding "OIL & FUEL RECOMMENDATIONS" item 2.

NEVER MIX OIL WITH GASOLINE

Never use "stale" gasoline left over from last season or stored for long periods.



NEVER FILL FUEL TANK INDOORS. NEVER FILL FUEL TANK WHEN ENGINE IS RUNNING OR HOT. DO NOT SMOKE WHEN FILL FUEL TANK.



NEVER FILL FUEL TANK COMPLETELY. FILL TANK TO 1/2" BELOW BOTTOM OF FILLER NECK TO PROVIDE SPACE FOR FUEL EXPANSION. WIPE ANY FUEL SPILLAGE FROM ENGINE AND EQUIPMENT BEFORE STARTING ENGINE.



ANY LIQUEFIED PETROLEUM (LPG) OR NATURAL GAS FUEL SYSTEM MUST BE LEAKPROOF AND MEET ALL APPLICABLE CODES AND REGULATIONS.

- ④ **CHECK THE FOLLOWING:**

- A. **BE SURE EQUIPMENT IS IN NEUTRAL GEAR WITH CLUTCHES, BELTS, CHAINS AND SAFETY SWITCHES DISENGAGED. (FOLLOW EQUIPMENT MANUFACTURER'S INSTRUCTIONS.) THIS SHOULD PLACE ANY SAFETY SWITCHES IN SAFE STARTING POSITION.**

- B. Be sure SPARK PLUG WIRE is attached to SPARK PLUG (see Figure 1).

- C. Insert ignition key into ignition keyslot in carburetor cover (see Figures 2 and 3).

NOTE: If engine is used for anything except snow removal, the CARBURETOR COVER (see Figure 1) must be removed, and an approved air cleaner installed. See your nearby Sears Roebuck and co. (or Sears Canada, Inc.) Service Center.

STARTING



NEVER RUN ENGINE INDOORS OR IN ENCLOSED, POORLY VENTILATED AREAS. ENGINE EXHAUST CONTAINS CARBON MONOXIDE, AN ODORLESS AND DEADLY GAS (CARBON MONOXIDE IS ALSO PRESENT IN ENGINE EXHAUST FROM LIQUID PETROLEUM (LPG) AND NATURAL GAS FUEL SYSTEMS).



KEEP HANDS, FEET, HAIR AND LOOSE CLOTHING AWAY FROM ANY MOVING PARTS ON ENGINE AND EQUIPMENT. NEVER LEAVE EQUIPMENT UNATTENDED WHEN ENGINE IS OPERATING.



WARNING - TEMPERATURE OF MUFFLER AND NEARBY AREAS MAY EXCEED 150°F (65°C). AVOID THESE AREAS.

- ① **RECOIL STARTER** (see Figure 1):

- A. Move engine CONTROL LEVER (see Figure 2) to "FAST".
B. Move engine CHOKE (see Figure 2) to "FULL".

NOTE: IF RESTARTING A WARM ENGINE AFTER A SHORT SHUTDOWN:

1. MOVE CHOKE TO "OFF" INSTEAD OF "FULL".
2. DO NOT USE PRIMER.

- C. Push PRIMER three (3) times (see Figure 2). Always cover vent hole when pushing primer.

STARTING (Continued)

- D. Grasp STARTER HANDLE (see Figure 2), and pull rope out, slowly, until it pulls slightly harder. Let rope rewind slowly. Then pull rope with a rapid full arm stroke. Let rope rewind SLOWLY. Do not let STARTER HANDLE snap back against starter.

NOTE: If RECOIL STARTER is frozen and won't crank engine, proceed as follows:

1. Pull as much rope out of starter as possible.
2. Release STARTER HANDLE and let it snap back against starter.

NOTE: The preceding should be done only when necessary to free a frozen starter.

- E. If engine fails to start after 3 pulls, repeat preceding instructions C - E, until engine starts.

- F. When engine starts, move CHOKE gradually "OFF".

- G. If engine falters, move CHOKE immediately to "FULL" and then gradually to "OFF".

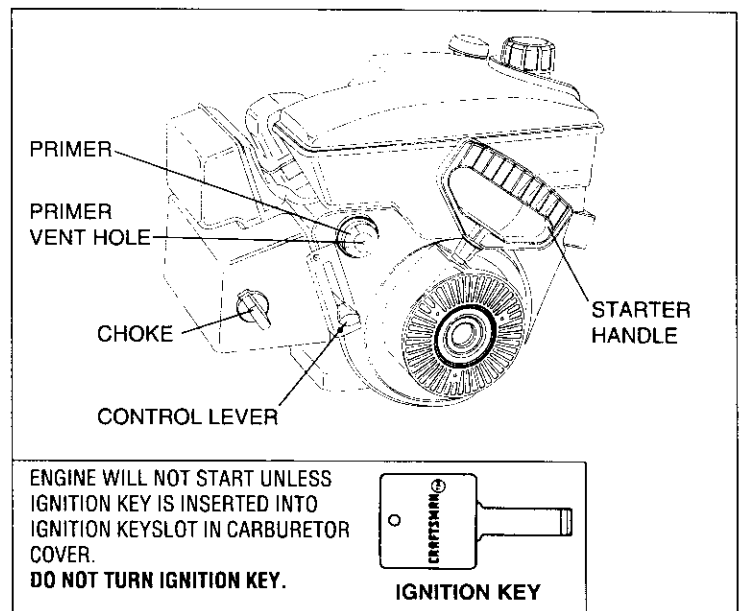

Figure 2

- ② **ELECTRIC STARTER - 120 VOLT A.C.** (see Figure 3):



WARNING - THIS STARTER IS EQUIPPED WITH A THREE-WIRE POWER CORD AND PLUG AND IS DESIGNED TO OPERATE ON 120 VOLT AC HOUSEHOLD CURRENT. IT MUST BE PROPERLY GROUNDED AT ALL TIMES TO AVOID THE POSSIBILITY OF ELECTRIC SHOCK WHICH MAY BE INJURIOUS TO THE OPERATOR. FOLLOW ALL INSTRUCTION CAREFULLY AS SET FORTH BELOW. DETERMINE THAT YOUR HOUSE WIRING IS A THREE-WIRE GROUNDED SYSTEM. ASK A LICENSED ELECTRICIAN IF YOU ARE NOT SURE. IF YOUR HOUSE WIRING SYSTEM IS NOT A THREE-WIRE GROUNDED SYSTEM, DO NOT USE THIS ELECTRIC STARTER UNDER ANY CONDITION. IF YOUR SYSTEM IS GROUNDED AND A THREE-HOLE RECEPTACLE IS NOT AVAILABLE AT THE POINT YOUR STARTER WILL NORMALLY BE USED, ONE SHOULD BE INSTALLED BY A LICENSED ELECTRICIAN.



WHEN CONNECTING 120 VOLT AC "POWER CORD", ALWAYS CONNECT CORD TO "SWITCH BOX" ON ENGINE FIRST, AND THEN PLUG THE OTHER END INTO THREE-HOLE GROUNDED RECEPTACLE.



WHEN DISCONNECTING "POWER CORD", ALWAYS UNPLUG THE END IN THE THREE-HOLE GROUNDED RECEPTACLE FIRST.

STARTING (Continued)

ELECTRIC STARTER (Continued - see Figure 3):

NOTE: THIS ELECTRIC STARTER IS THERMALLY PROTECTED. IF OVERHEATED IT WILL STOP AUTOMATICALLY, AND CAN BE RESTARTED ONLY WHEN IT HAS COOLED TO A SAFE TEMPERATURE. (AWAIT OF ABOUT 5 TO 10 MINUTES IS REQUIRED.)

NOTE: DO NOT USE PRIMER WHEN USING 120 VOLT ELECTRIC STARTER.

- Move engine CONTROL LEVER (see Figure 3) to "FAST".
- Move engine CHOKE (see Figure 3) to "OFF".
- Connect POWER CORD to SWITCHBOX (see Figure 3).
- Plug other end of POWER CORD into a three-hole, GROUNDED 120V, AC receptacle. (See "WARNING" at beginning of these instructions.)
- Push STARTER BUTTON (see Figure 3) to crank engine.
- Move engine CHOKE to "FULL" while cranking engine.
- When engine starts, release STARTER BUTTON and move CHOKE gradually to "OFF".
- If engine falters, move CHOKE immediately to "FULL", and then gradually to "OFF".
- Disconnect POWER CORD from receptacle first, and then from SWITCHBOX.

if, after following the preceding instructions, your engine fails to start, have it checked by your nearby Sears Roebuck and Co. (of Sears Canada, Inc.) Service Center.

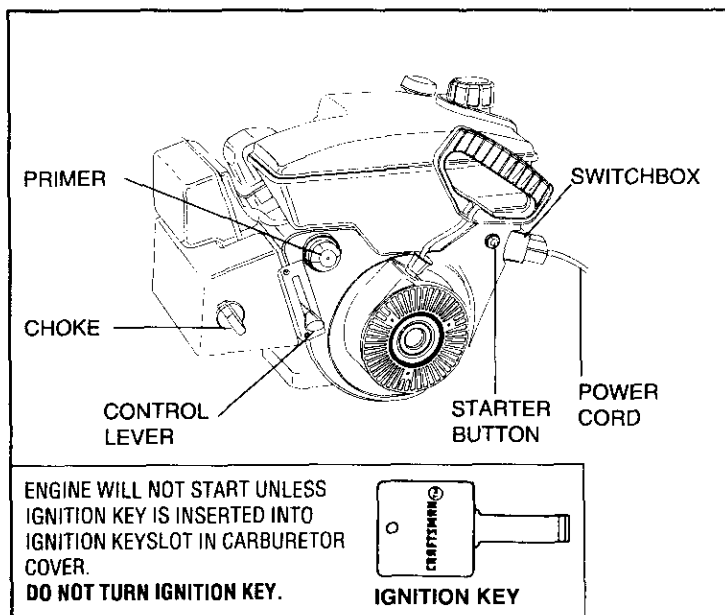

Figure 3

STOPPING

① BEFORE STOPPING (see Figure 3):

- Run engine for a few minutes to help dry off any moisture on engine.
- To help avoid possible freeze-up of starter, proceed as follows:

RECOIL STARTER:

With engine running, pull starter rope with a rapid continuous full arm stroke three (3) or four (4) times.

NOTE: The unusual sound made by pulling starter rope will not harm engine or starter.

STOPPING (Continued)

ELECTRIC STARTER:

- Connect power cord to switchbox, then to 120 Volt AC receptacle.
- With engine running, push starter button and spin starter for several seconds.

NOTE: The unusual sound made by spinning starter will not harm engine or starter.

- Disconnect power cord from receptacle first, and then from switchbox.

② STOP ENGINE (see Figure 3):

- Move control lever to "STOP" OR "OFF".
- Remove ignition key (see Figure 2 or 3) from carburetor cover.

DO NOT TURN IGNITION KEY.

③ AFTER ENGINE IS STOPPED (see Figure 3):

- To help avoid possible freeze-up of engine controls, proceed as follows:
 - Wipe all snow and moisture from engine in vicinity of control lever and choke.
 - Move equipment control (see equipment manufacturer's instructions) or engine control lever back and forth several times and leave in the "STOP" or "OFF" position.
 - Move engine choke back and forth several times and leave in the "FULL" position.

⚠ B. DISCONNECT SPARK PLUG WIRE FROM SPARK PLUG AND KEEP IT AWAY FROM SPARK PLUG.

⚠ C. REMOVE IGNITION KEY FROM CARBURETOR COVER. THIS WILL REDUCE THE POSSIBILITY OF UNAUTHORIZED STARTING OF ENGINE WHILE EQUIPMENT IS NOT IN USE.

⚠ NEVER STORE ENGINE WITH FUEL IN TANK INDOORS OR IN ENCLOSED, POORLY VENTILATED AREAS, WHERE FUEL FUMES MAY REACH AN OPEN FLAME, SPARK OR PILOT LIGHT AS ON A FURNACE, WATER HEATER, CLOTHES DRYER OR OTHER GAS APPLIANCE.

MAINTENANCE

⚠ WARNING - TEMPERATURE OF MUFFLER AND NEARBY AREAS MAY EXCEED 150°F (65°C). AVOID THESE AREAS.

① ENGINE OIL LEVEL:

Check oil level every five (5) operating hours or each time engine is used. See "2 CHECK OIL LEVEL" on Page 1.

② CHANGE OIL:

Change oil after first two (2) operating hours and every 25 operating hours thereafter, more often if operated in extremely dusty or dirty conditions. Change oil while engine is still warm from recent running.

- Clean area around oil drain plug.
- Position equipment so engine oil drain plug is lowest point on engine (see Figure 1).
- Remove oil drain plug and oil fill plug to drain oil.
- Replace oil drain plug and tighten securely.
- Fill oil sump with recommended oil. See "OIL & FUEL RECOMMENDATIONS" and "CHECK OIL LEVEL" on Page 1.
- Replace oil fill plug and tighten securely.
- Wipe up any spilled oil.

③ SPARK PLUG (see Figure 4):

This spark ignition system meets all requirements of the Canadian Interference-Causing Equipment Regulations. This engine complies with all current Australian and New Zealand limitations regarding electromagnetic interference. Check spark plug yearly or every 100 operating hours.

- Clean area around spark plug base.
- Remove and inspect spark plug.
- Replace spark plug if electrodes are pitted, burned or porcelain is cracked. For replacement use Champion RN4C or equivalent.
NOTE: A resistor spark plug must be used for replacement.
- Check electrodes gap with wire feeler gauge. Set gap at .030 if necessary.
- Install spark plug in engine and tighten securely.

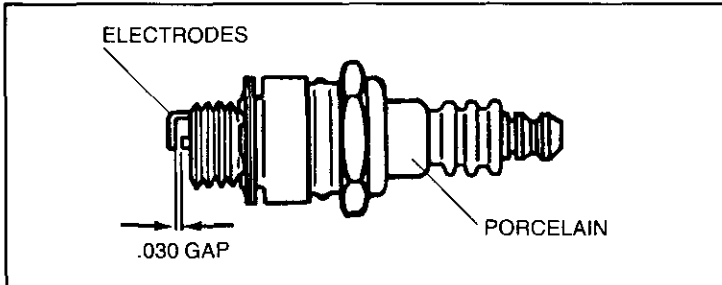

Figure 4

④ CHECK ENGINE AND EQUIPMENT OFTEN FOR LOOSE NUTS, BOLTS AND ATTACHMENTS AND KEEP THESE ITEMS TIGHTENED.

ADJUSTMENTS

DO NOT MAKE UNNECESSARY ADJUSTMENTS. FACTORY SETTINGS ARE SATISFACTORY FOR MOST APPLICATIONS AND CONDITIONS. IF ADJUSTMENTS ARE NEEDED, PROCEED AS FOLLOWS:

① CARBURETOR

If you think your carburetor needs adjusting, see your nearest SEARS, ROEBUCK AND CO. (OR SEARS CANADA, INC.) SERVICE CENTER. Engine performance should not be affected at altitudes up to 7,000 feet. For operation at higher elevations, contact your nearest SEARS, ROEBUCK AND CO. (OR SEARS CANADA, INC.) SERVICE CENTER.

② ENGINE SPEED

NEVER TAMPER WITH ENGINE GOVERNOR WHICH IS FACTORY SET FOR PROPER ENGINE SPEED. OVERSPEEDING ENGINE ABOVE FACTORY HIGH SPEED SETTING CAN BE DANGEROUS.
CHANGING OF ENGINE-GOVERNED SPEED WILL VOID ENGINE WARRANTY.

STORAGE

NEVER STORE ENGINE WITH FUEL IN TANK INDOORS OR IN ENCLOSED, POORLY VENTILATED AREAS, WHERE FUEL FUMES MAY REACH AN OPEN FLAME SPARK OR PILOT LIGHT AS ON A FURNACE, WATER HEATER, CLOTHES DRYER OR OTHER GAS APPLIANCE.

STORAGE (Continued)

IF ENGINE IS TO BE UNUSED FOR 30 DAYS OR MORE, PREPARE AS FOLLOWS:

① DRAIN FUEL SYSTEM:

Remove all gasoline from CARBURETOR and FUEL TANK to prevent gum deposits from forming on these parts and causing possible malfunction of engine.

! DRAIN FUEL INTO APPROVED CONTAINER OUTDOORS, AWAY FROM OPEN FLAME. BE SURE ENGINE IS COOL. DO NOT SMOKE.

Run engine until FUEL TANK is empty and engine stops due to lack of fuel.

NOTE: Fuel stabilizer (such as ULTRA-FRESH™) is an acceptable alternative in minimizing the formation of fuel gum deposits during storage. Add stabilizer to gasoline in fuel tank or storage container. Always follow mix ratio found on stabilizer container. Run engine at least 10 minutes after adding stabilizer to allow it to reach carburetor.

② DRAIN CARBURETOR:

Drain carburetor by pressing upward on bowl drain (see Figure 5), which is located below carburetor cover (see Figure 1).

! DRAIN FUEL INTO APPROVED CONTAINER OUTDOORS, AWAY FROM OPEN FLAME. BE SURE ENGINE IS COOL. DO NOT SMOKE.

NOTE: Do not drain carburetor if using fuel stabilizer.

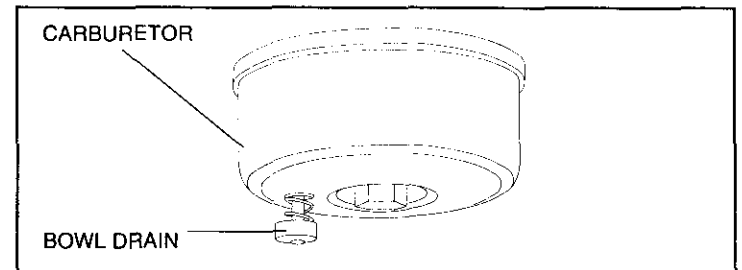

Figure 5

③ CHANGE OIL:

If oil has not been changed recently, this may be a good time to do it. See "CHANGE OIL" instructions in "MAINTENANCE" section.

④ OIL CYLINDER BORE:

- Remove spark plug. Squirt one (1) oz. (30 ml) of clean engine oil into spark plug hole.
- Cover spark plug hole with a rag.
- Crank engine over, slowly, several times.

! AVOID SPRAY FROM SPARK PLUG HOLE WHEN CRANKING ENGINE OVER SLOWLY.

- Install spark plug. Do not connect spark plug wire.

⑤ CLEAN ENGINE:

Remove any clippings, dirt, or chaff from exterior of engine.

GENERAL

Just as your automobile needs professional mechanical maintenance from time to time, so does your Craftsman engine. Replacement of the spark plug and ignition points is made necessary by NORMAL use. Professional Air-Cooled Engine Service is as close as your nearest Sears Roebuck and Co. (or Sears Canada, Inc.) Service Center.

A yearly check-up or tune-up by Sears is a good idea to avoid breakdowns or delay... do it at the end of the season, then you're ready for the next. We even prepare it for storage for you.

TROUBLESHOOTING

THE FOLLOWING MAY HELP AVOID A DELAY IN YOUR WORK OR
SAVE THE EXPENSE OF A SERVICE CALL.

ENGINE FAILS TO START OR STARTS WITH DIFFICULTY	
CAUSE	REMEDY
Controls not in start position.	Move ENGINE CONTROL or equipment control to "HI" or START position. See "STARTING" instructions in this manual.
Spark plug wire disconnected from spark plug.	Connect SPARK PLUG WIRE to SPARK PLUG.
Spark plug fouled.	Remove SPARK PLUG and clean it. See "SPARK PLUG" instructions in "MAINTENANCE" section in this manual.
Spark plug porcelain cracked.	Install new spark plug.
Insufficient fuel.	Fill FUEL TANK per "BEFORE STARTING" instructions.
Water or dirt in fuel.	Drain FUEL TANK and re-fill with clean, fresh gasoline. See "BEFORE STARTING" instructions in this manual.
Improper carburetor adjustment	Adjust carburetor (if applicable). See "ADJUSTMENTS" section in this manual.
ENGINE LACKS POWER	
CAUSE	REMEDY
Dirty air cleaner.	Replace or clean air cleaner per "AIR CLEANER" instructions in "MAINTENANCE" section in this manual.
Improper carburetor adjustment.	Adjust carburetor (if applicable). See "ADJUSTMENTS" section in this manual.
Lack of lubricaiton.	Fill oil sump to proper level. See "BEFORE STARTING" instructions section in this manual.
ENGINE MISSES UNDER LOAD	
CAUSE	REMEDY
Spark plug fouled.	Remove SPARK PLUG and clean it. See "SPARK PLUG" instructions in "MAINTENANCE" section in this manual.
Spark plug porcelain cracked.	Install new SPARK PLUG.
Improper spark plug gap.	Regap SPARK PLUG electrodes. See "SPARK PLUG" instructions in "MAINTENANCE" section in this manual.
Improper carburetor adjustment	Adjust carburetor (if applicable). See "ADJUSTMENTS" section in this manual.

SEARS, ROEBUCK AND CO.

Federal and California Emission Control Systems Limited Warranty Small Off-Road Engines

CALIFORNIA & US EPA EMISSION CONTROL WARRANTY STATEMENT

The U. S. Environmental Protection Agency ("EPA"), the California Air Resources Board ("CARB") and Sears, Roebuck and Co. are pleased to explain the Federal and California Emission Control Systems Warranty on your new small off-road engine. In California, new 1995 and later small off-road engines must be designed, built and equipped to meet the State's stringent anti-smog standards. In other states, new 1997 and later model year engines must be designed, built and equipped, at the time of sale, to meet the U.S. EPA regulations for small non-road engines. Sears, Roebuck and Co. will warrant the emission control system on your small off-road engine for the periods of time listed below, provided there has been no abuse, neglect, unapproved modification, or improper maintenance of your small off-road engine.

Your emission control system may include parts such as the carburetor, ignition system and exhaust system. Also included may be the compression release system and other emission-related assemblies.

Where a warrantable condition exists, Sears, Roebuck and Co. will repair your small off-road engine at no cost to you for diagnosis, parts and labor.

MANUFACTURER'S EMISSION CONTROL SYSTEM WARRANTY COVERAGE

Emission control systems on 1995 and later model year California small off-road engines are warranted for two years as hereinafter noted. In other states, 1997 and later model year engines are also warranted for two years. If, during such warranty period, any emission-related part on your engine is defective in materials or workmanship, the part will be repaired or replaced by Sears, Roebuck and Co.

OWNER'S WARRANTY RESPONSIBILITIES

As the small off-road engine owner, you are responsible for the performance of the required maintenance listed in your Owner's Manual, but Sears, Roebuck and Co. will not deny warranty solely due to the lack of receipts or for your failure to provide written evidence of the performance of all scheduled maintenance.

As the small off-road engine owner, you should, however, be aware that Sears, Roebuck and Co. may deny you warranty coverage if your small off-road engine or a part thereof has failed due to abuse, neglect, improper maintenance or unapproved modifications.

You are responsible for presenting your small off-road engine to a Sears, Roebuck and Co. Authorized Service Outlet as soon as a problem exists. The warranty repairs should be completed in a reasonable amount of time, not to exceed 30 days.

Warranty service can be arranged by contacting either a Sears, Roebuck and Co. Authorized Service Outlet, or by contacting Sears, Roebuck and Co. at 1-800-473-7247.

IMPORTANT NOTE

This warranty statement explains your rights and obligations under the Emission Control System Warranty ("ECS Warranty") which is provided to you by Sears, Roebuck and Co. pursuant to California law. See also the Sears, Roebuck and Co. Limited Warranties for Sears, Roebuck and Co. which is enclosed therewith on a separate sheet and also is provided to you by Sears, Roebuck and Co. The ECS Warranty applies only to the emission control system of your new engine. To the extent that there is any conflict in terms between the ECS Warranty and the Sears, Roebuck and Co. Warranty, the ECS Warranty shall apply except in any circumstances in which the Sears, Roebuck and Co. Warranty may provide a longer warranty period. Both the ECS Warranty and the Sears, Roebuck and Co. Warranty describe important rights and obligations with respect to your new engine.

Warranty service can only be performed by a Sears, Roebuck and Co. Authorized Service Outlet. At the time of requesting warranty service, evidence must be presented of the date of sale to the original purchaser. The purchaser shall pay any charges for making service calls and/or for transporting the products to and from the place where the inspection and/or warranty work is performed. The purchaser shall be responsible for any damage or loss incurred in connection with the transportation of any engine or any part(s) thereof submitted for inspection and/or warranty work.

If you have any questions regarding your warranty rights and responsibilities, you should contact Sears, Roebuck and Co. at 1-800-473-7247.

EMISSION CONTROL SYSTEM WARRANTY

Emission Control System Warranty ("ECS Warranty") for 1995 and later model year California small off-road engines (for other states, 1997 and later model year engines):

A. APPLICABILITY: This warranty shall apply to 1995 and later model year California small off-road engines (for other states, 1997 and later model year engines). The ECS Warranty Period shall begin on the date the new engine or equipment is delivered to its original, end-use purchaser, and shall continue for 24 consecutive months thereafter.

B. GENERAL EMISSIONS WARRANTY COVERAGE: Sears, Roebuck and Co. warrants to the original, end-use purchaser of the new engine or equipment and to each subsequent purchaser that each of its small off-road engines is:

1. Designed, built and equipped so as to conform with all applicable regulations adopted by the Air Resources Board pursuant to its authority in Chapters 1 and 2, Part 5, Division 26 of the Health and Safety Code, and
2. Free from defects in materials and workmanship which, at any time during the ECS Warranty Period, will cause a warranted emissions-related part to fail to be identical in all material respects to the part as described in the engine manufacturer's application for certification.

C. The ECS Warranty only pertains to emissions-related parts on your engine, as follows:

1. Any warranted, emissions-related parts which are not scheduled for replacement as required maintenance in the Owner's Manual shall be warranted for the ECS Warranty Period. If any such part fails during the ECS Warranty Period, it shall be repaired or replaced by Sears, Roebuck and Co. according to Subsection 4 below. Any such part repaired or replaced under the ECS Warranty shall be warranted for any remainder of the ECS Warranty Period.
2. Any warranted, emissions-related part which is scheduled only for regular inspection as specified in the Owner's Manual shall be warranted for the ECS Warranty Period. A statement in such written instructions to the effect of "repair or replace as necessary", shall not reduce the ECS Warranty Period. Any such part repaired or replaced under the ECS Warranty shall be warranted for the remainder of the ECS Warranty Period.
3. Any warranted, emissions-related part which is scheduled for replacement as required maintenance in the Owner's Manual, shall be warranted for the period of time prior to the first scheduled replacement point for that part. If the part fails prior to the first scheduled replacement, the part shall be repaired or replaced by Sears, Roebuck and Co. according to Subsection 4 below. Any such emissions-related part repaired or replaced under the ECS Warranty, shall be warranted for the remainder of the ECS Warranty Period prior to the first scheduled replacement point for such emissions-related part.
4. Repair or replacement of any warranted, emissions-related part under this ECS Warranty shall be performed at no charge to the owner at a Sears, Roebuck and Co. Authorized Service Outlet.
5. The owner shall not be charged for diagnostic labor which leads to the determination that a part covered by the ECS Warranty is in fact defective, provided that such diagnostic work is performed at a Sears, Roebuck and Co. Authorized Service Outlet.
6. Sears, Roebuck and Co. shall be liable for damages to other original engine components or approved modifications proximately caused by a failure under warranty of an emission-related part covered by the ECS Warranty.
7. Throughout the ECS Warranty Period, Sears, Roebuck and Co. shall maintain a supply of warranted emission-related parts sufficient to meet the expected demand for such emission-related parts.
8. Any Sears, Roebuck and Co. authorized and approved emission-related replacement part may be used in the performance of any ECS Warranty maintenance or repair and will be provided without charge to the owner. Such use shall not reduce Sears, Roebuck and Co. ECS Warranty obligations.
9. Unapproved add-on or modified parts may not be used to modify or repair a Sears, Roebuck and Co. engine. Such use voids this ECS Warranty and shall be sufficient grounds for disallowing an ECS Warranty claim. Sears, Roebuck and Co. shall not be liable hereunder for failures of any warranted parts of a Sears, Roebuck and Co. engine caused by the use of such an unapproved add-on or modified part.

EMISSION-RELATED PARTS INCLUDE THE FOLLOWING:

1. Carburetor Assembly and its Internal Components
 - a) Fuel filter
 - b) Carburetor gaskets
 - c) Intake pipe
2. Air Cleaner Assembly
 - a) Air filter element
3. Ignition System, including:
 - a) Spark plug
 - b) Ignition module
 - c) Flywheel assembly
4. Catalytic Muffler (if so equipped)
 - a) Muffler gasket (if so equipped)
 - b) Exhaust manifold (if so equipped)
5. Crankcase Breather Assembly and its Components
 - a) Breather connection tube

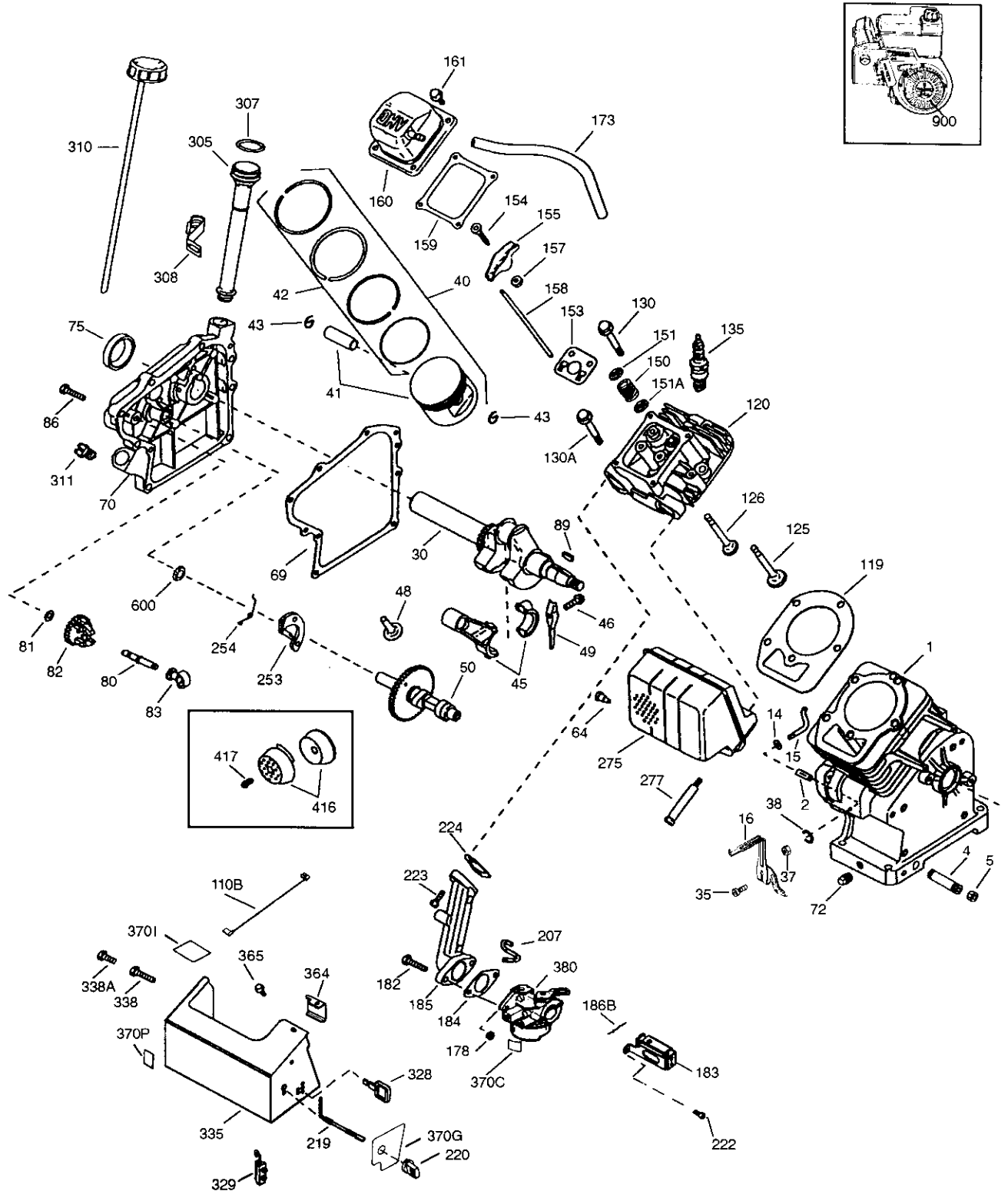

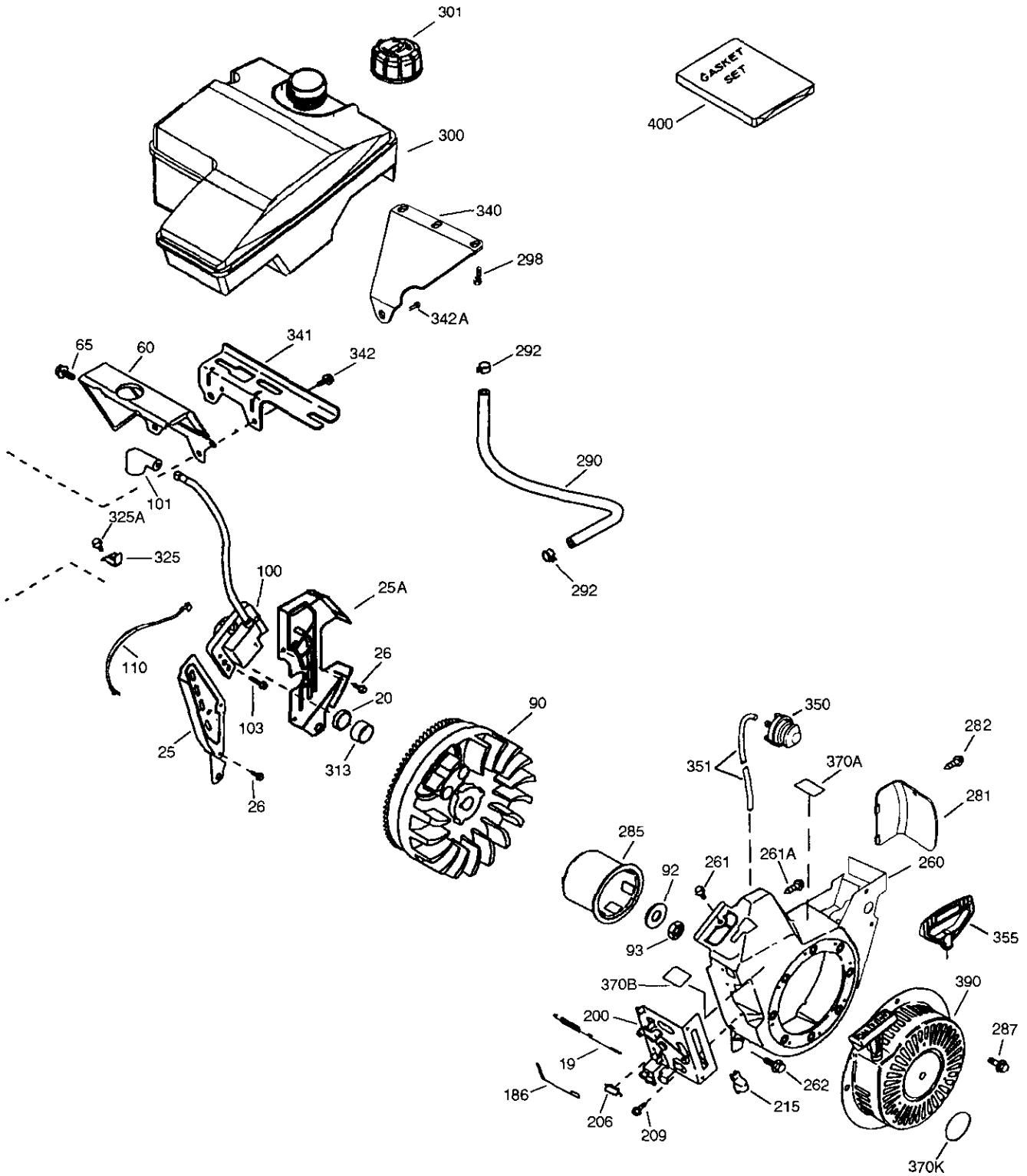

CRAFTSMAN 4-CYCLE ENGINE

MODEL: 143.026501

Ref. No.	Part No.	Part Name	Ref. No.	Part No.	Part Name
1	37120B	Cylinder (Incl. 2, 20 & 72)	185	36631	Intake Pipe
2	26727	Dowel Pin	186	36711	Governor Link
4	31857	Oil Drain Extension	186B	36652	Choke Spring
5	30969	Extension Cap	200	36824A	Control Bracket (Incl. 206)
14	651052	Washer	206	610973	Terminal
15	37108	Governor Rod	207	36632	Throttle Link
16	37110	Governor Lever	209	650821	Screw, 10-32 x 1/2"
19	37111	Extension Spring	215	32410	Control Knob
20	32600	Oil Seal	219	36868	Choke Rod
25	36621	Air Baffle (Left)	220	35438	Choke Knob
25A	36869	Air Baffle (Right)	222	28820	Screw, 10-32 x 1/2"
26	30200	Screw, 10-24 x 9/16"	223	650451	Screw, 1/4-20 x 1"
30	34740	Crankshaft	224	*36581	Intake Pipe Gasket
35	651053	Screw, 10-32 x 63/64"	253	36701	Compression Release Weight
37	29216	Lock Nut, 10-32	254	36702	Compression Release Spring
38	37109	Retaining Ring	260	36871A	Blower Housing
40	40004	Piston, Pin & Ring Set (Std.)	261	651008	Screw, 1/4-20 x 31/64"
40	40005	Piston, Pin & Ring Set (.010" OS)	261A	650821	Screw, 10-32 x 1/2"
41	36070	Piston & Pin Ass'y. (Std.) (Incl. 43)	262	651008	Screw, 1/4-20 x 31/64"
41	36071	Piston & Pin Ass'y. (.010" OS) (Incl. 43)	275	36722	Muffler
42	40006	Ring Set (Std.)	277	650988	Screw, 1/4-20 x 2-9/32"
42	40007	Ring Set (.010" OS)	281	36907	Starter Bubble Cover
43	20381	Piston Pin Retaining Ring	282	651035	Screw, 6-32 x 25/64"
45	32875A	Connecting Rod Ass'y. (Incl. 46 & 49)	285	35985B	Starter Cup
46	32610A	Connecting Rod Bolt	287	651008	Screw, 1/4-20 x 31/64"
48	35616	Valve Lifter	290	30705	Fuel Line
49	36611	Oil Dipper	292	26460	Fuel Line Clamp
50	37040	Camshaft (Incl. 253 & 254)	298	650665	Screw, 1/4-15 x 3/4"
60	36623A	Blower Housing Extension	300	36875	Fuel Tank (Incl. 292 & 301)
64	651027	Screw, 1/4-20 x 27/32"	301	35355	Fuel Cap
65	30200	Screw, 10-24 x 9/16"	305	36877	Oil Fill Tube
69	*36624	Cylinder Cover Gasket	307	35499	"O" Ring
70	36625	Cylinder Cover (Incl. 75 thru 83 & 311)	308	37079	Fill Tube Clip
72	27642	Oil Drain Plug	310	36878	Dipstick
75	27897	Oil Seal	311	27625	Oil Fill Plug
80	30574A	Governor Shaft	313	34080	Spacer
81	30590A	Washer	325	37471	Fuel Line Bracket
82	30591	Governor Gear Ass'y. (Incl. 81)	325A	30200	Screw, 10-24 x 9/16"
83	36057	Governor Spool	328	35593	Ignition Key
86	650488	Screw, 1/4-20 x 1-1/4"	329	610973	Terminal
89	610961	Flywheel Key	335	36873	Carburetor Cover
90	611216	Flywheel	338	650821	Screw, 10-32 x 1/2"
92	650815	Belleville Washer	338A	28942	Screw, 10-32 x 3/8"
93	650816	Flywheel Nut	340	37071	Fuel Tank Bracket (Upper)
100	34443B	Solid State Ignition	341	36644	Fuel Tank Bracket (Lower)
101	610118	Spark Plug Cover	342	651010	Screw, 1/4-20 x 7/8"
103	651007	Screw, T-15, 10-24 x 15/16"	342A	650738	Screw, 1/4-20 x 5/8"
110	36230	Ground Wire	350	570682A	Primer Assembly
110B	36874	Ground Wire	351	32180C	Primer Line
119	*36719	Cylinder Head Gasket	355	590574	Starter Handle (Mitten Grip)
120	37474	Cylinder Head	364	36872	Carburetor Cover Bracket
125	36471	Exhaust Valve (Std.) (Incl. 151)	365	650821	Screw, 10-32 x 1/2"
125	36472	Exhaust Valve (1/32" OS) (Incl. 151)	370A	36261	Lubrication Decal
126	29314C	Intake Valve (Std.) (Incl. 151)	370B	36899	Control Decal
130	650912	Screw, 5/16-18 x 1-1/2"	370C	36501	Primer Decal
130A	650999	Screw, 5/16-18 x 2-41/64"	370G	36906	Instruction Decal
135	34645	Resistor Spark Plug (RN4C)	370I	37119	Warning Decal
150	37039	Valve Spring	370K	36695	Starter Decal
151	31673	Valve Spring Cap	370P	35878	Heat Warning Decal
151A	40016A	Intake Valve Seal	380	640058	Carburetor (Incl. 184)
153	36649	Push Rod Guide	390	590749	Recoil Starter
154	650913	Rocker Arm Stud	400	36720	(NOTE: This engine could have been built with 590733 starter.)
155	35624A	Rocker Arm	416	36085	Gasket Set (Incl. Items Marked*)
157	650914	Nut, 1/4-28	417	650760	Spark Arrestor Kit (Incl. 417) (Optional)
158	36629	Push Rod	600	651013	Screw, 8-32 x 3/8"
159	*35626	Rocker Arm Cover Gasket	900	754300B	Washer
160	36630A	Rocker Arm Cover	900	754319A	Replacement Short Block order from 71-999
161	651008	Screw, 1/4-20 x 31/64"			Replacement Engine, order from 71-999
173	36675A	Breather Tube			
178	650852	Nut, 1/4-20			
182	650451	Screw, 1/4-20 x 1"			
183	36867	Choke Bracket			
184	*26756	Carburetor To Intake Pipe Gasket			

*Indicates Parts Included in Gasket Set, Ref. No. 400.
RPM High 3550 to 3850
RPM Low 1850 to 2150

CARBURETOR NO. 640058

Ref. No.	Part No.	Part Name
	640058	Carburetor (Incl. 184 of Engine Parts List)
1	631615	Throttle Shaft & Lever Assembly
2	631767	Throttle Return Spring
4	*631184	Dust Seal Washer
5	*631183	Dust Seal (Throttle)
6	631036	Throttle Shutter
7	*650506	Shutter Screw
10	632118	Choke Shaft & Lever Assembly
14	631890	Choke Shutter
15	630735	Choke Positioning Spring
16	632164	Fuel Fitting
17	650417	Throttle Crack Screw/Idle Speed Screw
18	630766	Tension Spring
20	640018	Idle Restrictor Screw
20A	640053	Idle Restrictor Screw Cap
25	631951	Float Bowl Ass'y (Incl. 32 & 33)
27	*631024	Float Shaft
28	632765	Float
29	*631028	Float Bowl "O" Ring
30	*631021	Inlet Needle, Seat & Clip (Incl. 31)
31	631022	Spring Clip
32	27136A	Bowl Drain Assembly
33	*27554	Drain Plunger Gasket
36	640019	Main Nozzle Tube
37	*632547	"O" Ring, Main Nozzle Tube
40	640059	High Speed Bowl Nut
44	27110A	Bowl Nut Washer
47	*630748	Welch Plug, Idle Mixture Well
48	*631027	Welch Plug, Atmospheric Vent
60	632760	Repair Kit (Incl. Items marked *)

REWIND STARTER NO. 590749

Ref. No.	Part No.	Part Name
	590749	Rewind Starter
1	590599A	Spring Pin (Incl. 4)
2	590600	Washer
3	590679	Retainer
4	590601	Washer
5	590678	Brake Spring
6	590680	Starter Dog
7	590412	Dog Spring
8	590682	Pulley & Rewind Spring Assembly
11	590750	Starter Housing Assembly
12	590535	Starter Rope (Length 98" x 9/64" dia.)
13	590574	Mitten Grip Handle (Not included with starter)

SEARS

operator's manual

MODEL NO. 143.026501

**5.0 HORSEPOWER
6.5 CUBIC INCH (195cc)
DISPLACEMENT**

SOLID STATE IGNITION

CAUTION:

Read **RULES** for
Safe **OPERATION**
and **INSTRUCTIONS**
Carefully

How to ORDER Repair Parts

The Model Number will be found stamped into the blower housing (See Figure 1). Always mention the Model Number when requesting service or repair parts for your Craftsman Engine.

All parts listed herein may be ordered from any SEARS, ROEBUCK AND CO. or SEARS CANADA, INC. retail or catalog store. If the parts you need are not stocked locally, your order will be electronically transmitted to a Sears Repair Parts Distribution Center for expedited handling.

WHEN ORDERING REPAIR PARTS, ALWAYS GIVE THE FOLLOWING INFORMATION AS SHOWN IN THIS LIST.

1. The PART NUMBER
2. The PART DESCRIPTION
3. The MODEL NUMBER
4. The NAME OF ITEM - ENGINE

"Your Sears merchandise has added value when you consider that Sears has service units nationwide staffed with Sears trained technicians... professional technicians specifically trained on Sears products, having the parts, tools and equipment to insure that we meet our pledge to you ... we service what we sell."

**Sold by SEARS, ROEBUCK AND CO., CHICAGO, IL 60684 U.S.A.
and SEARS CANADA, INC., TORONTO, ONTARIO, CANADA**