

Owner's Manual

CRAFTSMAN®

3/8 in. CORDLESS DRILL-DRIVER Variable Speed / Reversible

Model No.
973.111400

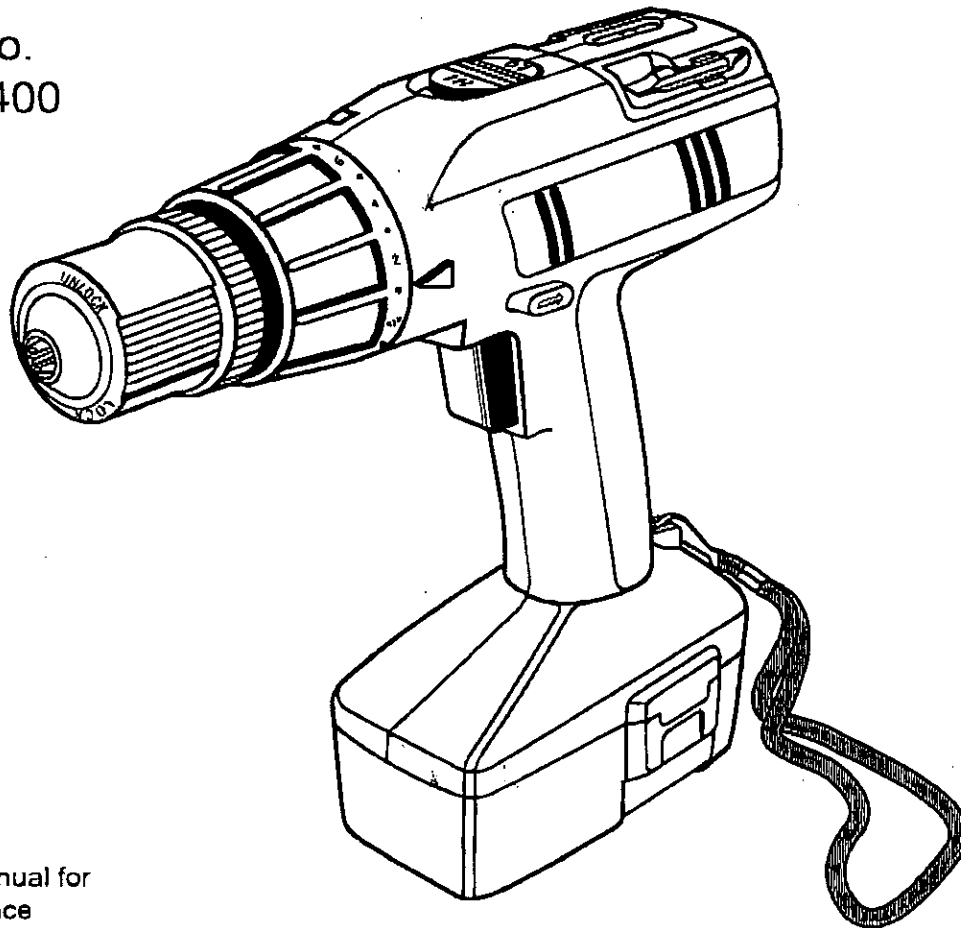

Save this manual for
future reference

▲ CAUTION: Read and follow all
Safety Rules and Operating Instructions
before first use of this product.

Customer Help Line: 1-800-932-3188

Sears, Roebuck and Co., Hoffman Estates, IL 60179 USA
Visit the Craftsman web page: www.sears.com/craftsman

972000-775
7-00

- Safety
- Features
- Operation
- Maintenance
- Parts List



TABLE OF CONTENTS

■ Warranty	2
■ Introduction and Product Specifications	2
■ Rules For Safe Operation	3-5
A. Important Safety Rules For Battery Tools	4
B. Important Safety Instructions For Charger	4
■ Accessories	6
■ Features	6
■ Operation	7-12
■ Maintenance	13
■ Battery Pack Removal and Preparation For Recycling	14
■ Exploded View and Repair Parts List	15
■ Parts Ordering / Service	16

WARRANTY

FULL ONE YEAR WARRANTY ON CRAFTSMAN 3/8 in. DRILL-DRIVER

If this **CRAFTSMAN** 3/8 in. Drill-Driver fails to give complete satisfaction within one year from the date of purchase, **RETURN IT TO THE NEAREST SEARS STORE OR SEARS SERVICE CENTER IN THE UNITED STATES**, and Sears will repair it, free of charge.

If this **CRAFTSMAN** 3/8 in. Drill-Driver is used for commercial or rental purposes, this warranty applies for only 90 days from the date of purchase.

This warranty gives you specific legal rights, and you may also have other rights which vary from state to state.

Sears, Roebuck and Co., Dept. 817WA, Hoffman Estates, IL 60179

INTRODUCTION

Your drill-driver has many features for making drilling operations more pleasant and enjoyable. Safety, performance and dependability have been given top priority in the design of this drill-driver making it easy to maintain and operate.

 **CAUTION:** Carefully read through this entire owner's manual before using your new drill-driver. Pay close attention to the Rules For Safe Operation, Warnings and Cautions. If you use your drill-driver properly and only for what it is intended, you will enjoy years of safe, reliable service.

SPECIFICATIONS:

Chuck Capacity	3/8 in.
Motor	16.8 Volts DC
Charger Rating	120 Volts, 60 Hz, AC Only
No Load Speed	0 - 350 / 0 - 1300 RPM
Switch	Variable Speed - Reversible
Charge Rate	1 Hour

RULES FOR SAFE OPERATION

The purpose of safety symbols is to attract your attention to possible dangers. The safety symbols, and the explanations with them, deserve your careful attention and understanding. The safety warnings do not by themselves eliminate any danger. The instructions or warnings they give are not substitutes for proper accident prevention measures.

SYMBOL MEANING



SAFETY ALERT SYMBOL:

Indicates warning or caution. May be used in conjunction with other symbols or pictographs.



WARNING: Failure to obey a safety warning can result in serious injury to yourself or to others. Always follow the safety precautions to reduce the risk of fire, electric shock and personal injury.



CAUTION: Failure to obey a safety warning may result in property damage or personal injury to yourself or to others. Always follow the safety precautions to reduce the risk of fire, electric shock and personal injury.

NOTE: Advises you of information or instructions vital to the operation or maintenance of the equipment.



WARNING: Do not attempt to operate this tool until you have read thoroughly and understand completely all instructions, safety rules, etc. contained in this manual. Failure to comply can result in accidents involving fire, electric shock, or serious personal injury. Save owner's manual and review frequently for continuing safe operation, and instructing others who may use this tool.

READ ALL INSTRUCTIONS

- **KNOW YOUR POWER TOOL.** Read owner's manual carefully. Learn its applications and limitations as well as the specific potential hazards related to this tool.
- **GUARD AGAINST ELECTRICAL SHOCK** by preventing body contact with grounded surfaces. For example: Pipes, radiators, ranges, refrigerator enclosures.
- **KEEP WORK AREA CLEAN.** Cluttered areas and benches invite accidents.
- **AVOID DANGEROUS ENVIRONMENT.** Don't use power tool in damp or wet locations or expose to rain. Keep work area well lit.
- **KEEP CHILDREN AND VISITORS AWAY.** All visitors should wear safety glasses and be kept a safe distance from work area. Do not let visitors contact tool or extension cord.
- **STORE IDLE TOOLS.** When not in use tools should be stored in a dry and high or locked-up place - out of the reach of children.
- **DON'T FORCE TOOL.** It will do the job better and safer at the rate for which it was designed.
- **USE RIGHT TOOL.** Don't force small tool or attachment to do the job of a heavy duty tool. Don't use tool for purpose not intended - for example - A circular saw should never be used for cutting tree limbs or logs.
- **WEAR PROPER APPAREL.** Do not wear loose clothing or jewelry that can get caught in tool's moving parts and cause personal injury. Rubber gloves and nonskid footwear are recommended when working outdoors. Wear protective hair covering to contain long hair and keep it from being drawn into nearby air vents.
- **ALWAYS WEAR SAFETY GLASSES.** Everyday eyeglasses have only impact-resistant lenses; they are **NOT** safety glasses.
- **PROTECT YOUR LUNGS.** Wear a face mask or dust mask if operation is dusty.
- **PROTECT YOUR HEARING.** Wear hearing protection during extended periods of operation.
- **SECURE WORK.** Use clamps or a vise to hold work. It's safer than using your hand and it frees both hands to operate tool.
- **DON'T OVERREACH.** Keep proper footing and balance at all times. Do not use on a ladder or unstable support.
- **MAINTAIN TOOLS WITH CARE.** Keep tools sharp at all times, and clean for best and safest performance. Follow instructions for lubricating and changing accessories.
- **REMOVE ADJUSTING KEYS AND WRENCHES.** Form habit of checking to see that keys and adjusting wrenches are removed from tool before turning it on.

RULES FOR SAFE OPERATION (Continued)

- **NEVER USE IN AN EXPLOSIVE ATMOSPHERE.** Normal sparking of the motor could ignite flammable liquids, gases, or fumes.
- **KEEP HANDLES DRY, CLEAN, AND FREE FROM OIL AND GREASE.** Always use a clean cloth when cleaning. Never use brake fluids, gasoline, petroleum-based products or any strong solvents to clean your tool.
- **STAY ALERT.** Watch what you are doing and use common sense. Do not operate tool when you are tired. Do not rush.
- **CHECK DAMAGED PARTS.** Before further use of the tool, a guard or other part that is damaged should be carefully checked to determine that it will operate properly and perform its intended function. Check for alignment of moving parts, binding of moving parts, breakage of parts, mounting, and any other conditions that may affect its operation. A guard or other part that is damaged should be properly repaired or replaced by an authorized service center unless indicated elsewhere in this instruction manual.
- **DO NOT USE TOOL IF SWITCH DOES NOT TURN IT ON AND OFF.** Have defective switches replaced by an authorized service center.
- **DRUGS, ALCOHOL, MEDICATION.** Do not operate tool while under the influence of drugs, alcohol, or any medication.
- **DRILLING OR DRIVING SCREWS INTO ELECTRICAL WIRING IN WALLS, CEILINGS, OR OTHER AREAS CAN CAUSE THE BIT OR CHUCK TO BECOME ELECTRICALLY LIVE.** Do not touch metal parts when drilling; grasp only the insulated handle(s) or plastic housing when using this tool. Make sure hidden electrical wiring, water pipes, and mechanical hazards are not in the path of the bit when drilling into a wall.
- **INSPECT FOR** and remove all nails from lumber before drilling.

IMPORTANT SAFETY RULES FOR BATTERY TOOLS

- Battery tools do not have to be plugged into an electrical outlet; therefore, they are always in operating condition. Be aware of possible hazards when not using your battery tool or when changing accessories.
- **USE ONLY THE CHARGER PROVIDED WITH YOUR BATTERY TOOL.** Do not substitute any other charger. Use of another charger could cause batteries to explode causing possible serious injury.

- **DO NOT PLACE BATTERY TOOLS OR THEIR BATTERIES NEAR FIRE OR HEAT.** They may explode.
- **DO NOT CHARGE BATTERY TOOL IN A DAMP OR WET LOCATION.**
- Your battery tool should be charged in a location where the temperature is more than 50°F but less than 100°F.
- Under extreme usage or temperature conditions, battery leakage may occur. If liquid comes in contact with your skin, wash immediately with soap and water, then neutralize with lemon juice or vinegar. If liquid gets in your eyes, flush them with clean water for at least 10 minutes, then seek immediate medical attention.
- If carrying your battery tool at your side, make sure it is not running and your finger is not on the switch. Avoid accidental starting.
- **SECURE WORK** before applying power. **NEVER** hold workpiece in your hand or across your legs.
- **WHEN SERVICING USE ONLY IDENTICAL CRAFTSMAN REPLACEMENT PARTS.**

IMPORTANT SAFETY INSTRUCTIONS FOR CHARGER

- **SAVE THESE INSTRUCTIONS.** This manual contains important safety and operating instructions for charger item number 9-11118 (982139-001).
- Before using battery charger, read all instructions and cautionary markings in this manual, on battery charger, and product using battery charger.
- ▲ **WARNING:** To reduce risk of injury, charge only nickel-cadmium type rechargeable batteries. Other types of batteries may burst causing personal injury and damage.
- Do not expose charger to rain or snow.
- Use of an attachment not recommended or sold by the battery charger manufacturer may result in a risk of fire, electric shock, or injury to persons.
- To reduce risk of damage to charger body and cord, pull by plug body rather than cord when disconnecting charger.
- Make sure cord is located so that it will not be stepped on, tripped over, or otherwise subjected to damage or stress.

RULES FOR SAFE OPERATION (Continued)

- An extension cord should not be used unless absolutely necessary. Use of improper extension cord could result in a risk of fire and electric shock. If extension cord must be used, make sure:
 - a. That pins on plug of extension cord are the same number, size and shape as those of plug on charger.
 - b. That extension cord is properly wired and in good electrical condition; and
 - c. That wire size is large enough for AC ampere rating of charger as specified below:
Cord Length (Feet) 25' 50' 100'
Cord Size (AWG) 16 16 16
Note: AWG = American Wire Gauge
- **DO NOT OPERATE CHARGER WITH A DAMAGED CORD OR PLUG.** If damaged, have replaced immediately by a qualified serviceman.
- Do not operate charger if it has received a sharp blow, been dropped, or otherwise damaged in any way; take it to a qualified serviceman.
- Do not disassemble charger; take it to a qualified serviceman when service or repair is required. Incorrect reassembly may result in a risk of electric shock or fire.
- To reduce risk of electric shock, unplug charger from outlet before attempting any maintenance or cleaning. Turning off controls will not reduce this risk.

- Do not use charger outdoors.
- Disconnect charger from power supply when not in use.
- **SAVE THESE INSTRUCTIONS.** Refer to them frequently and use them to instruct others who may use this tool. If you loan someone this tool, loan them these instructions also.

⚠ WARNING: Some dust created by power sanding, sawing, grinding, drilling, and other construction activities contains chemicals known to cause cancer, birth defects or other reproductive harm. Some examples of these chemicals are:

- lead from lead-based paints,
- crystallite silica from bricks and cement and other masonry products, and
- arsenic and chromium from chemically-treated lumber.

Your risk from these exposures varies, depending on how often you do this type of work. To reduce your exposure to these chemicals: work in a well ventilated area, and work with approved safety equipment, such as those dust masks that are specially designed to filter out microscopic particles.

⚠ Look for this symbol to point out important safety precautions. It means attention!!! Your safety is involved.

⚠ WARNING:



The operation of any power tool can result in foreign objects being thrown into your eyes, which can result in severe eye damage. Before beginning power tool operation, always wear safety goggles or safety glasses with side shields and a full face shield when needed. We recommend Wide Vision Safety Mask for use over eyeglasses or standard safety glasses with side shields, available at Sears Retail Stores.

ACCESSORIES

The following recommended accessories are currently available at Sears Retail Stores.

- 6-Pc. Extra Length Magnite Power Bit Set
- 30-Pc. Power Screwdriver/Nutdriver Set and Case
- 17-Pc. Power Screwdriver/Nutdriver Set and Case
- High Speed Bits (For Wood or Metal)..3/4 in. Max.
- Keyless Chuck (Item No. 9-20988)

⚠ WARNING: The use of attachments or accessories not listed might be hazardous.

FEATURES

KNOW YOUR DRILL-DRIVER

See Figure 1.

Before attempting to use any tool familiarize yourself with all operating features and safety requirements.

WRIST STRAP

See Figure 1.

A wrist strap is provided to reduce the chances of dropping your drill-driver. Place one hand through the wrist strap when carrying tool.

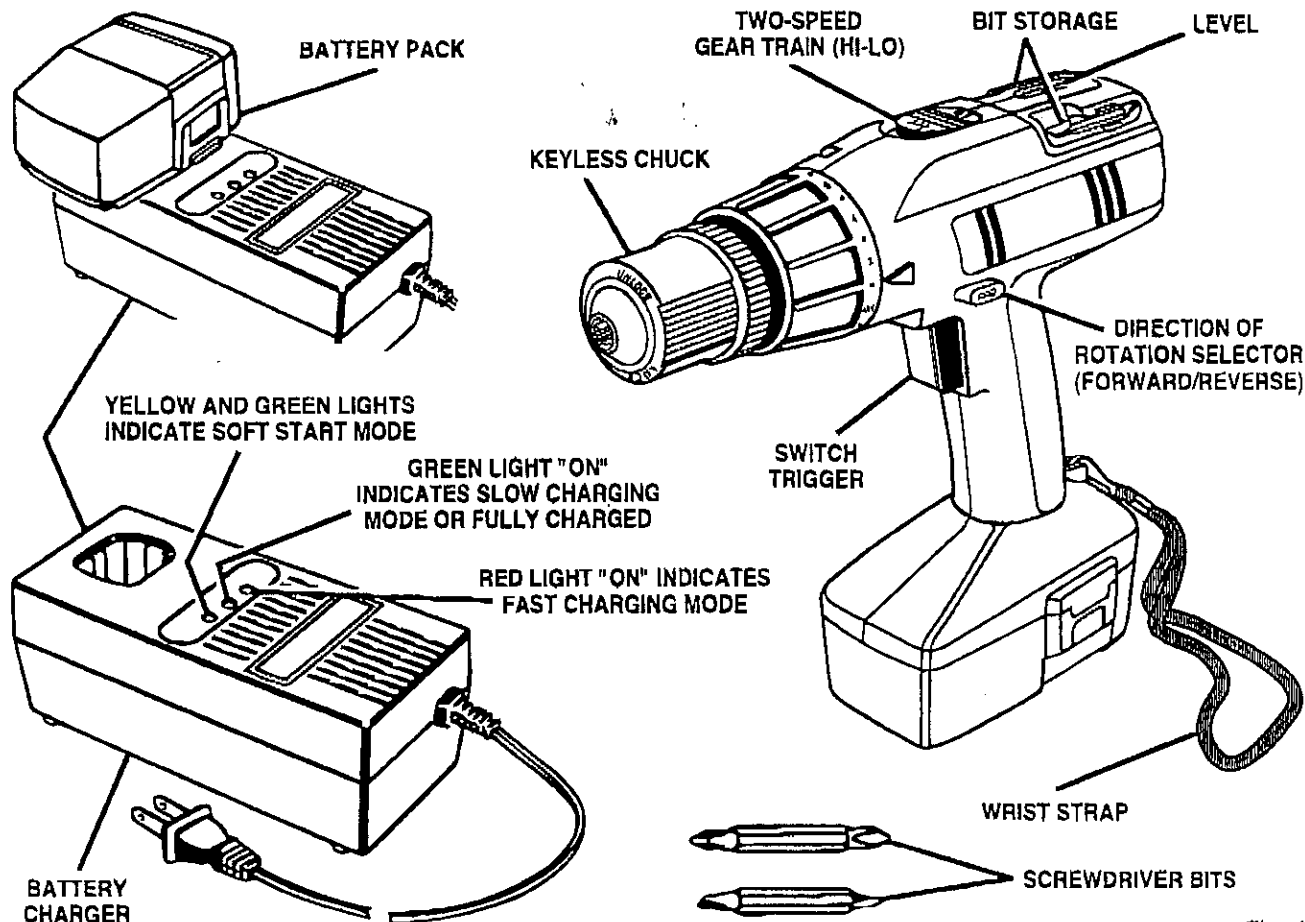

Fig. 1

⚠ WARNING: If any parts are missing, do not operate tool until the missing parts are replaced. Failure to do so could result in possible serious personal injury.

OPERATION

⚠ WARNING: Always wear safety goggles or safety glasses with side shields when operating tools. Failure to do so could result in objects being thrown into your eyes, resulting in possible serious injury.

⚠ WARNING: Do not allow familiarity with your drill-driver to make you careless. Remember that a careless fraction of a second is sufficient to inflict severe injury.

CHARGING BATTERY PACK

The battery pack for this tool has been shipped in a low charge condition to prevent possible problems. Therefore, you should charge it until light on front of charger changes from red to green.

Note: Batteries will not reach full charge the first time they are charged. Allow several cycles (drilling followed by recharging) for them to become fully charged.

TO CHARGE

- Charge battery pack only with the charger provided.
- Make sure power supply is normal household voltage, 120 volts, 60 Hz, AC only.
- Connect charger to power supply.
- Place battery pack in charger aligning raised rib in charger with groove in battery pack.
- Press down on battery pack to be sure contacts on battery pack engage properly with charger contacts.
- Normally, the yellow and green lights on charger will come on. This indicates charger is in soft start mode and should switch to fast charge mode within 5 minutes. When charger is in fast charge mode the red light will come on. If after a period of 15 minutes the yellow and green lights remain on, remove battery pack, wait 1 minute and reinsert battery pack in charger. If the yellow and green lights continue to remain on after an additional 15 minutes, the battery pack is damaged and will not accept a charge. Return battery pack to your nearest Sears Repair Center for checking or replacing.

- When your battery pack becomes fully charged, the red light will turn OFF and the green light will turn ON.
- After normal usage, 1 hour of charging time is required to be fully charged. A minimum charge time of 1-1/2 hours is required to recharge a completely discharged tool.
- The battery pack will become slightly warm to the touch while charging. This is normal and does not indicate a problem.
- Do not place charger in an area of extreme heat or cold. It will work best at normal room temperature.
- When batteries become fully charged, unplug charger from power supply and remove the battery pack.

IMPORTANT INFORMATION FOR RECHARGING HOT BATTERIES

When using your drill-driver continuously, the batteries in your battery pack will become hot. You should let a hot battery pack cool down for approximately 30 minutes before attempting to recharge. When the battery pack becomes discharged and is hot, this will cause the yellow and green lights on your battery charger to come on instead of the red light. The yellow and green lights indicate soft start mode and will switch to green only, indicating slow charge mode. The red light indicates fast charge mode, 1 hour charge time. The green light indicates slow charge mode, requiring overnight charging for batteries to reach full charge. If the green light comes on after letting battery pack cool down, remove it from charger for additional cooling. Once the battery pack cools down, you can recharge battery pack in fast charge mode as normal. Do not leave a hot battery pack in charger until it cools down. The green light will not go off when battery pack cools. If fast charge mode is desired, you must physically remove a hot battery pack from the charger, let it cool, then place it back in charger after it has cooled down.

Note: This situation only occurs when continuous use of your drill causes the batteries to become hot. It does not occur under normal circumstances. Refer to "CHARGING BATTERY PACK" for normal recharging of batteries. If the charger does not charge your battery pack under normal circumstances, return both the battery pack and charger to your nearest Sears repair center for electrical check.

OPERATION

SWITCH

See Figure 2.

To turn your drill **ON**, depress the switch trigger. To turn it **OFF**, release the switch trigger.

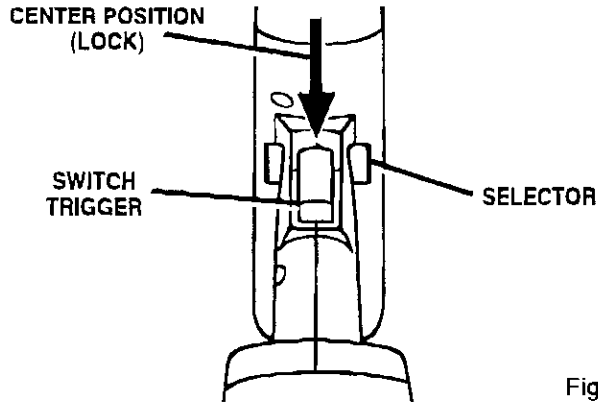

Fig. 2

VARIABLE SPEED

This tool has a variable speed switch that delivers higher speed and torque with increased trigger pressure. Speed is controlled by the amount of switch trigger depression.

Note: You might hear a whistling or ringing noise from the switch during use. Do not be concerned, this is a normal part of the switch function.

TWO-SPEED GEAR TRAIN

See Figure 3.

Your drill has a two-speed gear train designed for drilling or driving at **HI** or **LO** speeds. A slide switch is located on top of your drill to select either **HI** or **LO** speed. When using drill in the **HI** speed range, speed will increase and unit will have less power and torque. When using drill in the **LO** speed range, speed will decrease and unit will have more power and torque. Use **HI** speed for fast drilling or driving applications and **LO** speed for high power and torque applications.

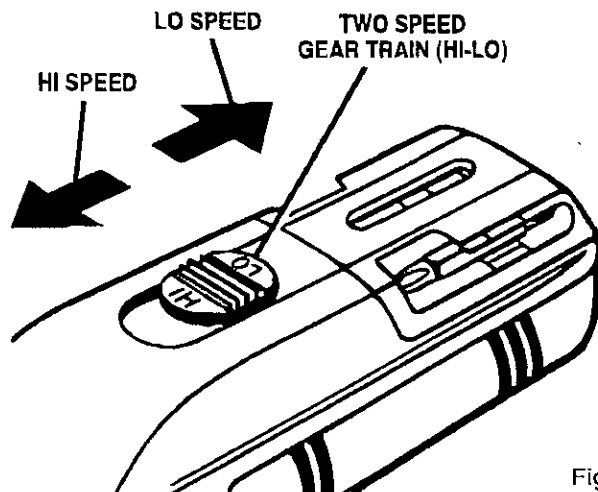

Fig. 3

TO INSTALL BATTERY PACK

- Lock switch trigger on your drill by placing the direction of rotation selector in center position. See Figure 5.
- Place battery pack in your drill. Align raised rib inside drill with groove on battery pack. See Figures 4.

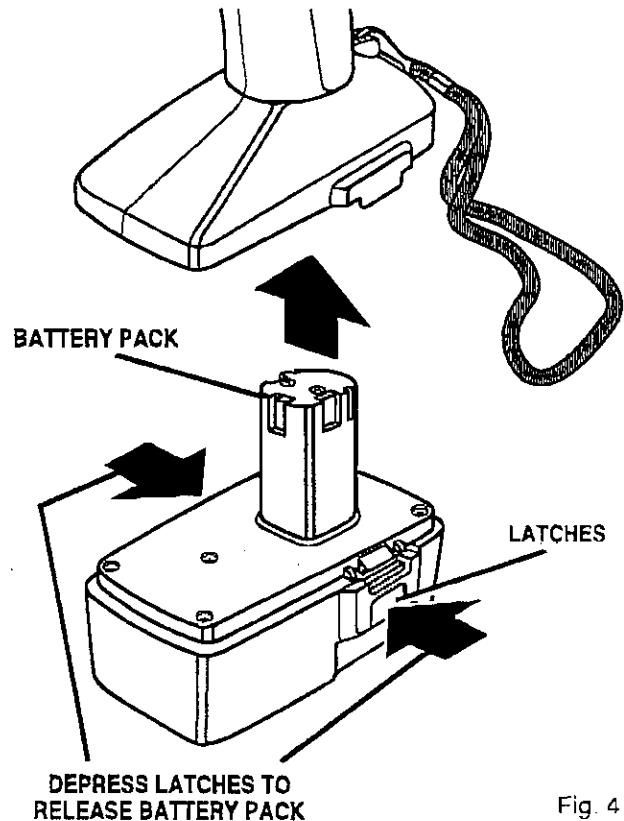

Fig. 4

- Make sure the latches on each side of your battery pack snap in place and battery pack is secured in drill before beginning operation.

CAUTION: When placing battery pack in your drill, be sure raised rib inside drill aligns with groove on battery pack and latches snap into place properly. Improper assembly of battery pack can cause damage to internal components.

TO REMOVE BATTERY PACK

- Lock switch trigger on your drill by placing the direction of rotation selector in center position. See Figure 5.
- Locate latches on end of battery pack and depress to release battery pack from your drill. See Figure 4.
- Remove battery pack from your drill.

OPERATION

SWITCH LOCK

See Figure 5.

The switch trigger can be locked in the OFF position. This feature can be used to prevent the possibility of accidental starting when not in use. To lock switch trigger, place the direction of rotation selector in center position.

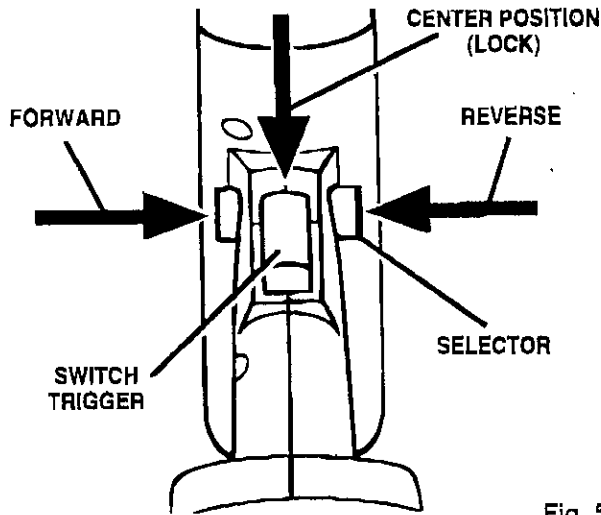

Fig. 5

WARNING: Battery tools are always in operating condition. Therefore, switch should always be locked when not in use or carrying at your side.

REVERSIBLE

See Figure 5.

This tool has the feature of being reversible. The direction of rotation is controlled by a selector located above the switch trigger. With the drill held in normal operating position, the direction of rotation selector should be positioned to the left of the switch for drilling. The drilling direction is reversed when the selector is to the right of the switch. When the selector is in center position, the switch trigger is locked.

CAUTION: To prevent gear damage, always allow chuck to come to a complete stop before changing the direction of rotation or the two-speed gear train (hi-lo).

To stop, release switch trigger and allow the chuck to come to a complete stop.

CHARGER

See Figure 6.

Your charger has a "key hole" hanging feature for convenient, space saving storage. Screws should be installed so that center distances are 1-7/16 inches apart.

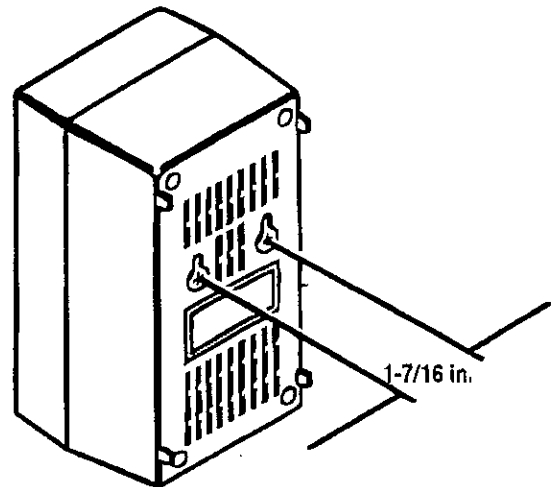

BACKSIDE OF CHARGER

Fig. 6

KEYLESS CHUCK

See Figure 7.

Your drill has a keyless chuck. As the name implies, you can hand tighten or release drill bits in the chuck jaws. Grasp and hold the collar of the chuck with one hand. Rotate the chuck body with your other hand. The arrows on the chuck indicate which direction to rotate the chuck body in order to LOCK (tighten) or UNLOCK (release) the drill bit.

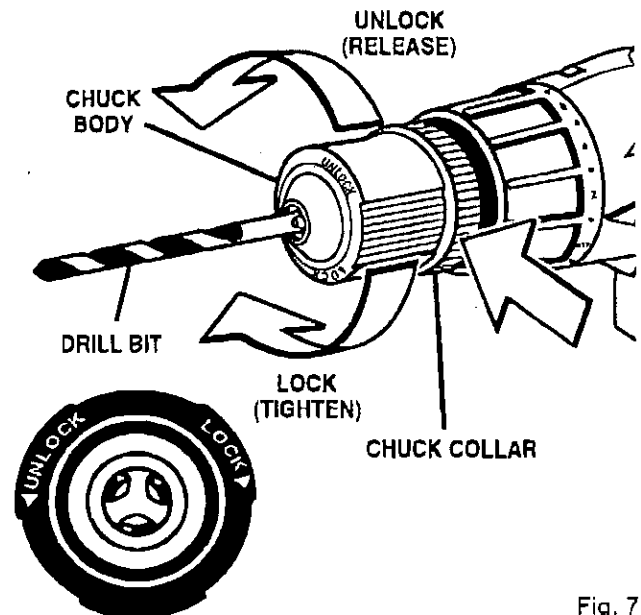

Fig. 7

WARNING: Do not hold chuck body with one hand and use power of the drill to tighten chuck jaws on drill bits. Chuck body could slip in your hand or your hand could slip and come in contact with rotating drill bit. This could cause an accident resulting in serious personal injury.

OPERATION

INSTALLING BITS

See Figure 8.

- Lock the switch trigger by placing the direction of rotation selector in center position. See Figure 5.
- Open or close chuck jaws to a point where the opening is slightly larger than the bit size you intend to use. Also, raise the front of your drill slightly to keep the bit from falling out of the chuck jaws.
- Insert drill bit straight into chuck the full length of the jaws as shown in Figure 8.
- Tighten the chuck jaws on drill bit.

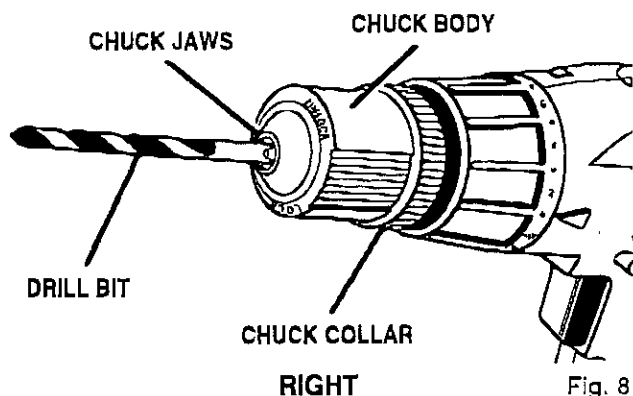

- To tighten the chuck jaws on drill bit; grasp and hold the collar of the chuck with one hand, while rotating the chuck body with your other hand.
Note: Rotate the chuck body in the direction of the arrow marked **LOCK** to tighten chuck jaws.
- **Do not** use a wrench to tighten or loosen the chuck jaws.

⚠ WARNING: Make sure to insert drill bit straight into chuck jaws. Do not insert drill bit into chuck jaws at an angle then tighten as shown in Figure 9. This could cause drill bit to be thrown from drill, resulting in possible serious personal injury or damage to the chuck.

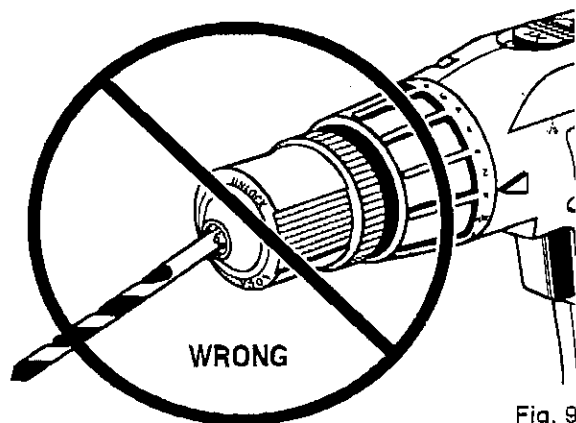

REMOVING BITS

See Figure 8.

- Lock the switch trigger by placing the direction of rotation selector in center position. See Figure 5.
- Loosen the chuck jaws from drill bit.
- To loosen; grasp and hold the collar of the chuck with one hand, while rotating chuck body with your other hand. **Note:** Rotate chuck body in the direction of the arrow marked **UNLOCK** to loosen chuck jaws.
- **Do not** use a wrench to tighten or loosen the chuck jaws.
- Remove drill bit from chuck jaws.

ADJUSTABLE TORQUE CLUTCH

Your drill is equipped with an adjustable torque clutch for driving different types of screws into different materials. The proper setting depends on the type of material and the size of screw you are using.

TO ADJUST TORQUE

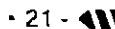
- Identify the twenty four torque indicator settings located on the front of your drill. See Figure 10.
- Rotate adjusting ring to the desired setting.
 - 1 - 4 For driving small screws.
 - 5 - 8 For driving screws into soft material.
 - 9 - 12 For driving screws into soft and hard materials.
 - 13 - 16 For driving screws in hard wood.
 - 17 - 20 For driving large screws.
 - 21 -  For heavy drilling.

TO DECREASE TORQUE

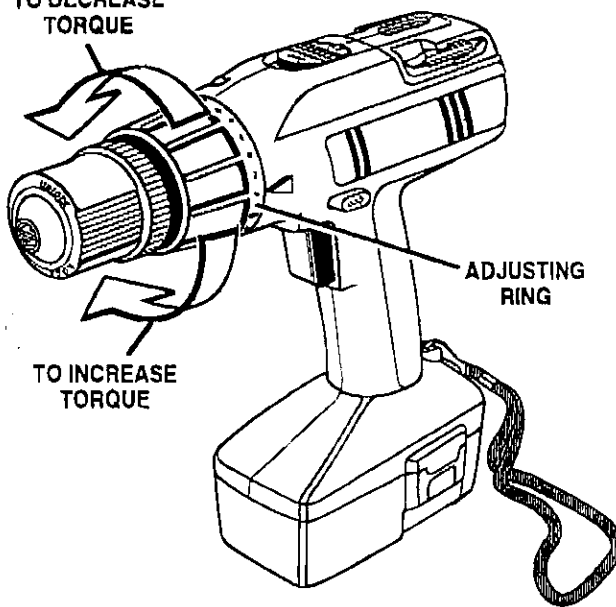

OPERATION

Note: Remember the two-speed feature (HI-LO) when setting torque. The amount of torque will vary depending on which speed setting you have your drill-driver. Switching to LO speed will increase torque. Switching to HI speed will decrease torque.

BIT STORAGE

See Figure 11.

When not in use, bits provided with your drill can be placed in the storage area located on the top of your drill as shown in Figure 11.

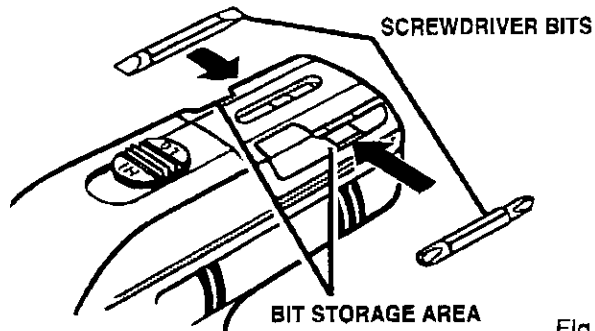

Fig. 11

WARNING: Always wear safety goggles or safety glasses with side shields when operating tools. Failure to do so could result in objects being thrown into your eyes, resulting in possible serious injury.

LEVEL DRILLING

See Figure 12.

A convenient new feature provided with your drill is a level. It is recessed in the motor housing on top of your drill. It can be used to keep drill bits level during drilling operations.

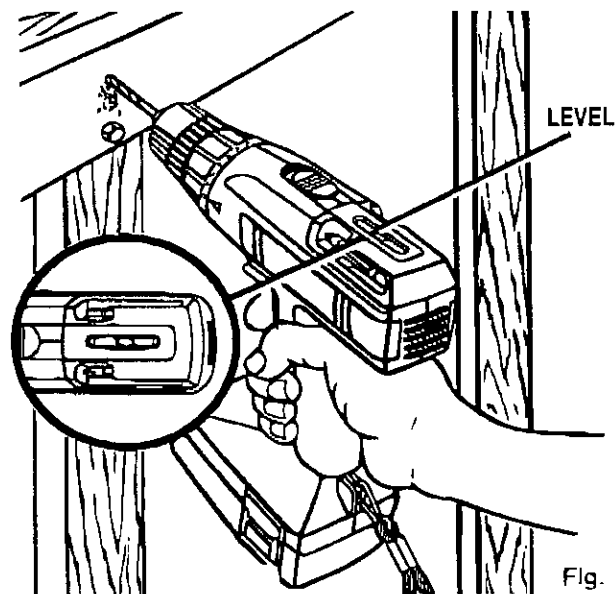

Fig. 12

DRILLING

See Figure 13.

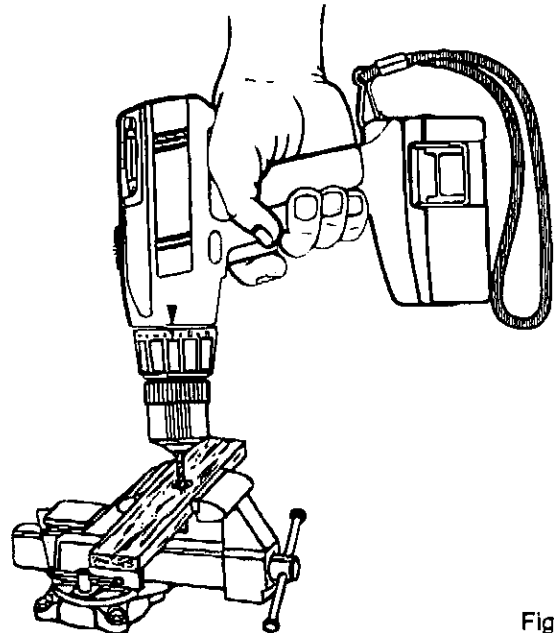

Fig. 13

When drilling hard smooth surfaces use a center punch to mark desired hole location. This will prevent the drill bit from slipping off center as the hole is started. However, the low speed feature allows starting holes without center punching if desired. To accomplish this, simply operate your drill at a low speed until the hole is started.

The material to be drilled should be secured in a vise or with clamps to keep it from turning as the drill bit rotates.

Hold tool firmly and place the bit at the point to be drilled. Depress the switch trigger to start tool.

Move the drill bit into the workpiece applying only enough pressure to keep the bit cutting. Do not force or apply side pressure to elongate a hole.

WARNING: Be prepared for binding or bit breakthrough. When these situations occur, drill has a tendency to grab and kick opposite to the direction of rotation and could cause loss of control when breaking through material. If not prepared, this loss of control can result in possible serious injury.

When drilling metals, use a light oil on the drill bit to keep it from overheating. The oil will prolong the life of the bit and increase the drilling action.

If the bit jams in workpiece or if the drill stalls, release switch trigger immediately. Remove the bit from the workpiece and determine the reason for jamming.

OPERATION

CHUCK REMOVAL

See Figures 14, 15, and 16.

The chuck must be removed in order to use some accessories. To remove:

- Lock the switch trigger by placing the direction of rotation selector in center position. See Figure 5.
- Insert a 5/16 inch or larger hex key wrench into the chuck of your drill and tighten the chuck jaws securely.
- Tap the hex key wrench sharply with a mallet in a clockwise direction. See Figure 14. This will loosen the screw in the chuck for easy removal.

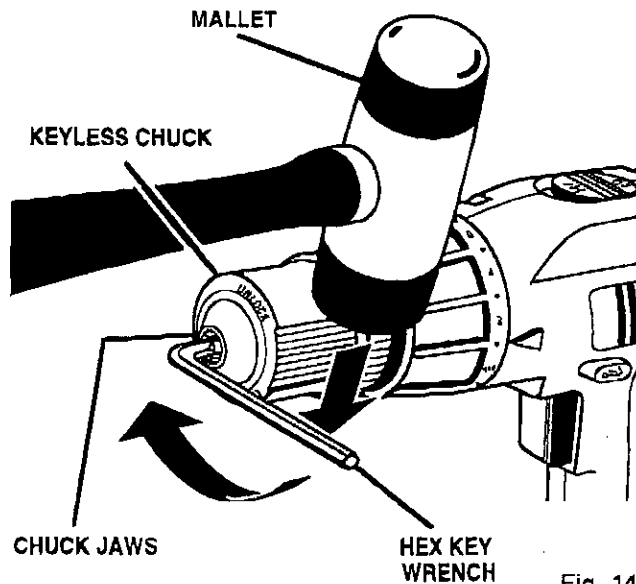

Fig. 14

- Open chuck jaws and remove wrench. Remove the chuck screw by turning it in a clockwise direction. See Figure 15.

Note: The screw has left hand threads.

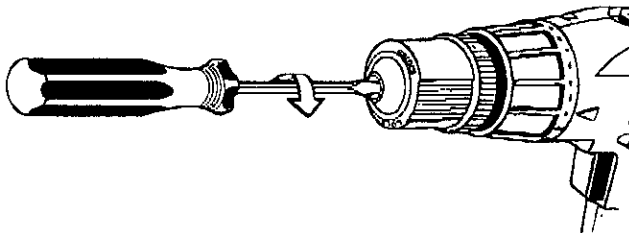

Fig. 15

- Insert hex key wrench in chuck and tighten chuck jaws securely. Tap sharply with a mallet in a counterclockwise direction. This will loosen chuck on the spindle. It can now be unscrewed by hand. See Figure 16.

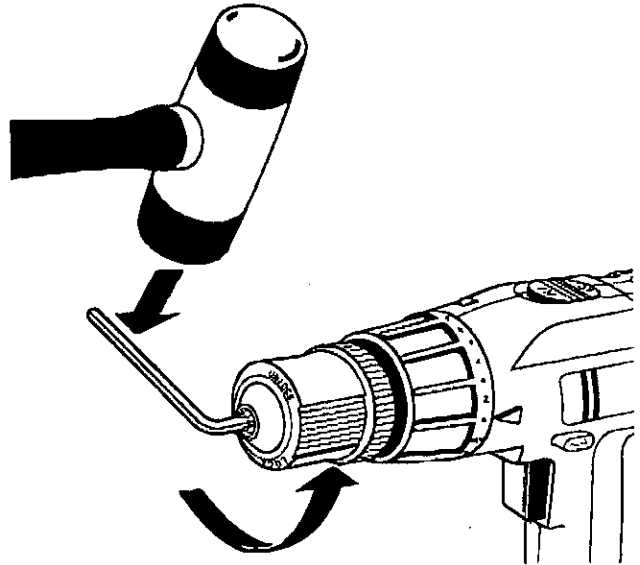

Fig. 16

TO RETIGHTEN A LOOSE CHUCK

The chuck may become loose on spindle and develop a wobble. Periodically check chuck screw for tightness. A loose screw may cause the chuck jaws to bind and prevent them from closing.

To tighten, follow these steps:

- Lock the switch trigger by placing the direction of rotation selector in center position. See Figure 5.
- Open the chuck jaws.
- Insert hex key wrench into chuck and tighten chuck jaws securely. Tap hex key wrench sharply with a mallet in a clockwise direction. This will tighten chuck on the spindle.
- Open the chuck jaws and remove hex key wrench.
- Tighten the chuck screw.

Note: The chuck screw has left hand threads.

MAINTENANCE

⚠ WARNING: When servicing, use only identical Craftsman replacement parts. Use of any other part may create a hazard or cause product damage.

Avoid using solvents when cleaning plastic parts. Most plastics are susceptible to damage from various types of commercial solvents and may be damaged by their use. Use clean cloths to remove dirt, dust, oil, grease, etc.

⚠ WARNING: Do not at any time let brake fluids, gasoline, petroleum-based products, penetrating oils, etc. come in contact with plastic parts. They contain chemicals that can damage, weaken or destroy plastic.

Do not abuse power tools. Abusive practices can damage tool as well as workpiece.

Only the parts shown on parts list, page 15, are intended to be repaired or replaced by the customer. All other parts should be replaced by a Sears Service Center.

⚠ WARNING: Do not attempt to modify this tool or create accessories not recommended for use with this tool. Any such alteration or modification is misuse and could result in a hazardous condition leading to possible serious personal injury.

BATTERIES

Your drill's battery pack is equipped with nickel-cadmium rechargeable batteries. Length of service from each charging will depend on the type of work you are doing.

The batteries in this tool have been designed to provide maximum trouble free life. However, like all batteries, they will eventually wear out. **Do not** disassemble battery pack and attempt to replace the batteries. Handling of these batteries, especially when wearing rings and jewelry, could result in a serious burn.

To obtain the longest possible battery life, we suggest the following:

- Store and charge your batteries in a cool area. Temperatures above normal room temperature will shorten battery life.
- Never store batteries in a discharged condition. Recharge them immediately after they are discharged.
- All batteries gradually lose their charge. The higher the temperature the quicker they lose their charge. If you store your tool for long periods of time without using it, recharge the batteries every month or two. This practice will prolong battery life.

OVERLOAD

Your drill has a built-in overload protector to protect the motor during overloading or prolonged use. The overload protector automatically activates to break the circuit. When this occurs, allow your drill to cool a few seconds before resuming operation.

CRAFTSMAN 3/8 in. CORDLESS DRILL-DRIVER - MODEL NO. 973.111400

The model number will be found on a plate attached to the motor housing. Always mention the model number in all correspondence regarding your 3/8 in. CORDLESS DRILL-DRIVER or when ordering repair parts.

SEE BACK PAGE FOR PARTS ORDERING INSTRUCTIONS

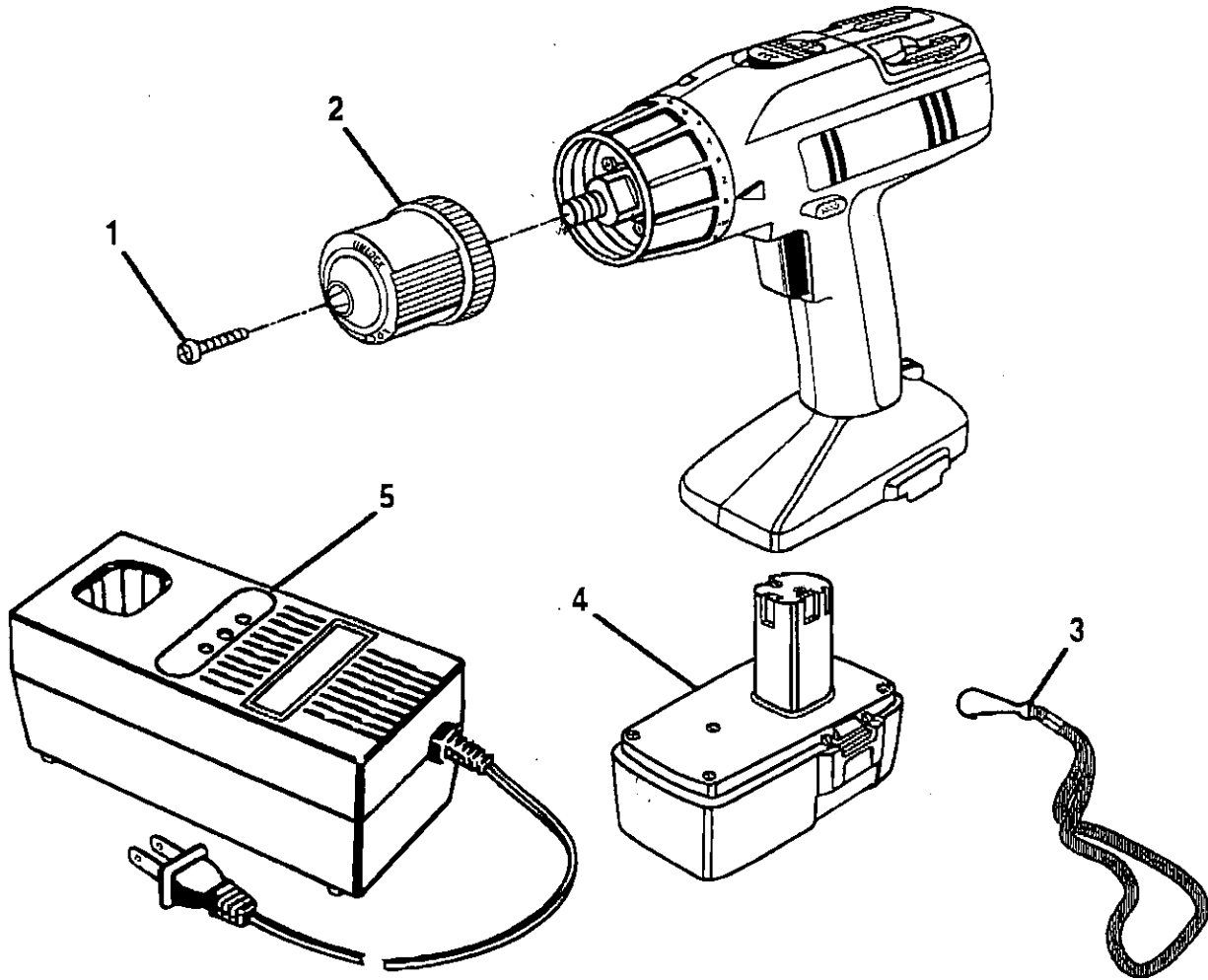

PARTS LIST

Key No.	Part Number	Description	Quan.
1	616478-003	Screw (Special)	1
2	973015-001	Chuck (Item No. 9-20988)	1
3	967216-004	Wrist Strap	1
4	* Item No. 9-11117	Battery Pack (982138-001)	1
5	* Item No. 9-11118	Charger (982139-001)	1
6	982143-001	Carrying Case - Not Shown	1
	972000-775	Owner's Manual	

* Can Be Purchased Thru RSOS (Retail Special Order System)