

Owner's Manual



**4.5 HORSEPOWER  
22" ECONOMY  
SIDE DISCHARGE  
ROTARY LAWN MOWER**

Model No.  
**917.388223**

- **Safety**
- **Assembly**
- **Operation**
- **Maintenance**
- **Español**
- **Repair Parts**



**CAUTION:**

Read and follow all  
Safety Rules and Instructions  
before operating this equipment

Sears, Roebuck and Co., Hoffman Estates, IL 60179  
Visit our Craftsman website: [www.sears.com/craftsman](http://www.sears.com/craftsman)

## TABLE OF CONTENTS

|                            |    |                               |            |
|----------------------------|----|-------------------------------|------------|
| Warranty .....             | 2  | Product Specifications .....  | 11         |
| Safety Rules .....         | 2  | Service and Adjustments ..... | 14         |
| Assembly .....             | 5  | Storage .....                 | 15         |
| Operation .....            | 6  | Troubleshooting .....         | 16         |
| Maintenance Schedule ..... | 10 | Repair Parts .....            | 35         |
| Maintenance .....          | 10 | Parts Ordering .....          | Back Cover |

## WARRANTY

### LIMITED TWO YEAR WARRANTY ON CRAFTSMAN POWER MOWER

For two years from date of purchase, when this Craftsman Lawn Mower is maintained, lubricated, and tuned up according to the operating and maintenance instructions in the owner's manual, Sears will repair free of charge any defect in material or workmanship.

If this Craftsman Lawn Mower is used for commercial or rental purposes, this warranty applies for only 90 days from the date of purchase.

This Warranty does not cover:

- Expendable items which become worn during normal use, such as rotary mower blades, blade adapters, belts, air cleaners and spark plug.
- Repairs necessary because of operator abuse or negligence, including bent crankshafts and the failure to maintain the equipment according to the instructions contained in the owner's manual.

Warranty service is available by returning the Craftsman power mower to the nearest Sears Service Center/Department in the United States. This warranty applies only while this product is in use in the United States.

This Warranty gives you specific legal rights, and you may also have other rights which vary from state to state.

SEARS, ROEBUCK AND CO., D/817 WA, HOFFMAN ESTATES, ILLINOIS 60179

## SAFETY RULES

**IMPORTANT:** This cutting machine is capable of amputating hands and feet and throwing objects. Failure to observe the following safety instructions could result in serious injury or death.

### I. GENERAL OPERATION

- Read, understand, and follow all instructions on the machine and in the manual(s) before starting. Be thoroughly familiar with the controls and the proper use of the machine before starting.
- Do not put hands or feet near or under rotating parts. Keep clear of the discharge opening at all times.
- Only allow responsible individuals, who are familiar with the instructions, to operate the machine.
- Clear the area of objects such as rocks, toys, wire, bones, sticks, etc., which could be picked up and thrown by the blade.
- Be sure the area is clear of other people before mowing. Stop machine if anyone enters the area.
- Do not operate the mower when barefoot or wearing open sandals. Always wear substantial foot wear.
- Do not pull mower backwards unless absolutely necessary. Always look down and behind before and while moving backwards.
- Do not operate the mower without proper guards, plates, grass catcher or other safety protective devices in place.
- See manufacturer's instructions for proper operation and installation of accessories. Only use accessories approved by the manufacturer.

- Stop the blade(s) when crossing gravel drives, walks, or roads.
- Stop the engine (motor) whenever you leave the equipment, before cleaning the mower or unclogging the chute.
- Shut the engine (motor) off and wait until the blade comes to complete stop before removing grass catcher.
- Mow only in daylight or good artificial light.
- Do not operate the machine while under the influence of alcohol or drugs.
- Never operate machine in wet grass. Always be sure of your footing: keep a firm hold on the handle and walk; never run.
- Disengage the self-propelled mechanism or drive clutch on mowers so equipped before starting the engine (motor).
- If the equipment should start to vibrate abnormally, stop the engine (motor) and check immediately for the cause. Vibration is generally a warning of trouble.
- Always wear safety goggles or safety glasses with side shields when operating mower.

## II. SLOPE OPERATION

Slopes are a major factor related to slip and fall accidents which can result in severe injury. All slopes require extra caution. If you feel uneasy on a slope, do not mow it.

### DO:

- Mow across the face of slopes: never up and down. Exercise extreme caution when changing direction on slopes.
- Remove obstacles such as rocks, tree limbs, etc.
- Watch for holes, ruts, or bumps. Tall grass can hide obstacles.

### DO NOT:

- Do not trim near drop-offs, ditches or embankments. The operator could lose footing or balance.
- Do not trim excessively steep slopes.
- Do not mow on wet grass. Reduced footing could cause slipping.

## III. CHILDREN

Tragic accidents can occur if the operator is not alert to the presence of children. Children are often attracted to the machine and the mowing activity. *Never* assume that children will remain where you last saw them.

- Keep children out of the trimming area and under the watchful care of another responsible adult.

- Be alert and turn machine off if children enter the area.
- Before and while walking backwards, look behind and *down* for small children.
- Never allow children to operate the machine.
- Use extra care when approaching blind corners, shrubs, trees, or other objects that may obscure vision.

## IV. SERVICE

- Use extra care in handling gasoline and other fuels. They are flammable and vapors are explosive.
  - Use only an approved container.
  - Never remove gas cap or add fuel with the engine running. Allow engine to cool before refueling. Do not smoke.
  - Never refuel the machine indoors.
  - Never store the machine or fuel container inside where there is an open flame, such as a water heater.
- Never run a machine inside a closed area.
- Never make adjustments or repairs with the engine (motor) running. Disconnect the spark plug wire, and keep the wire away from the plug to prevent accidental starting.
- Keep nuts and bolts, especially blade attachment bolts, tight and keep equipment in good condition.
- Never tamper with safety devices. Check their proper operation regularly.
- Keep machine free of grass, leaves, or other debris build-up. Clean oil or fuel spillage. Allow machine to cool before storing.
- Stop and inspect the equipment if you strike an object. Repair, if necessary, before restarting.
- Never attempt to make wheel height adjustments while the engine (motor) is running.
- Grass catcher components are subject to wear, damage, and deterioration, which could expose moving parts or allow objects to be thrown. Frequently check components and replace with manufacturer's recommended parts, when necessary.
- Mower blades are sharp and can cut. Wrap the blade(s) or wear gloves, and use extra caution when servicing them.
- Do not change the engine governor setting or overspeed the engine.

**⚠** Look for this symbol to point out important safety precautions. It means **CAUTION!!! BECOME ALERT!!! YOUR SAFETY IS INVOLVED.**

**⚠ WARNING:** In order to prevent accidental starting when setting up, transporting, adjusting or making repairs, always disconnect spark plug wire and place wire where it cannot contact spark plug.





**⚠ WARNING:** Engine exhaust, some of its constituents, and certain vehicle components contain or emit chemicals known to the State of California to cause cancer and birth defects or other reproductive harm.

**⚠ WARNING:** Battery posts, terminals and related accessories contain lead and lead compounds, chemicals known to the State of California to cause cancer and birth defects or other reproductive harm. **Wash hands after handling.**



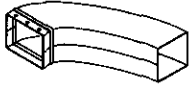

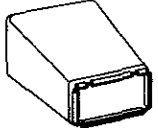

## ACCESSORIES

These accessories were available when this lawn mower was produced. **They are not shipped with your mower.** They are also available at most Sears retail outlets and service centers. Most Sears stores can also order repair parts for you, when you provide the model number of your lawn mower. Some of these accessories may not apply to your lawn mower.

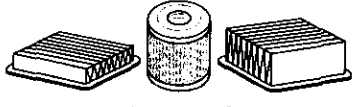
### LAWN MOWER PERFORMANCE

|  |  |  |
|--|--|--|
| <br><b>CLIPPING DEFLECTOR</b><br>FOR REAR DISCHARGE LAWN MOWERS | <br><b>MULCHER KITS</b>                                     | <br><b>STABILIZER</b> |
| <br><b>GRASS CATCHERS</b><br>FOR REAR DISCHARGE LAWN MOWERS      | <br><b>GRASS CATCHERS</b><br>FOR SIDE DISCHARGE LAWN MOWERS | <br><b>GAS CANS</b>   |

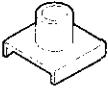
### LAWN MOWER MAINTENANCE

|   |  |  |  |   |
|---|--|--|--|---|
| <br><b>MUFFLERS</b> |  | <br><b>AIR FILTERS</b>    |  | <br><b>SPARK PLUGS</b> |
| <br><b>BELTS</b>    | <br><b>BLADES</b> | <br><b>BLADE ADAPTERS</b> | <br><b>WHEELS</b> | <br><b>ENGINE OIL</b>  |

## ASSEMBLY

Read these instructions and this manual in its entirety before you attempt to assemble or operate your new lawn mower.

**IMPORTANT:** This lawn mower is shipped WITHOUT OIL OR GASOLINE in the engine.

Your new lawn mower has been assembled at the factory with the exception of those parts left unassembled for shipping purposes. All parts such as nuts, washers, bolts, etc., necessary to complete the assembly have been placed in the parts bag. To ensure safe and proper operation of your lawn mower, all parts and hardware you assemble must be tightened securely. Use the correct tools as necessary to ensure proper tightness.

### TO REMOVE LAWN MOWER FROM CARTON

1. Remove loose parts included with mower.
2. Cut down two end corners of carton and lay end panel down flat.
3. Remove all packing materials except padding between upper and lower handle and padding holding operator presence control bar to upper handle.
4. Roll lawn mower out of carton and check carton thoroughly for additional loose parts.

### HOW TO SET UP YOUR LAWN MOWER

#### TO UNFOLD HANDLE

**IMPORTANT:** Unfold handle carefully so as not to pinch or damage control cables.

1. Raise handles until lower handle section locks into place in mowing position.
2. Remove protective padding, raise upper handle section into place on lower handle and tighten both handle knobs.
3. Remove handle padding holding operator presence control bar to upper handle.

Your lawn mower handle can be adjusted for your mowing comfort. Refer to "Adjust Handle" in the Service and Adjustments section of this manual.

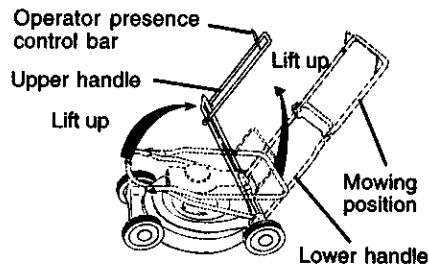

## OPERATION

### KNOW YOUR LAWN MOWER

READ THIS OWNER'S MANUAL AND SAFETY RULES BEFORE OPERATING YOUR LAWN MOWER. Compare the illustrations with your lawn mower to familiarize yourself with the location of various controls and adjustments. Save this manual for future reference.

These symbols may appear on your lawn mower or in literature supplied with the product. Learn and understand their meaning.

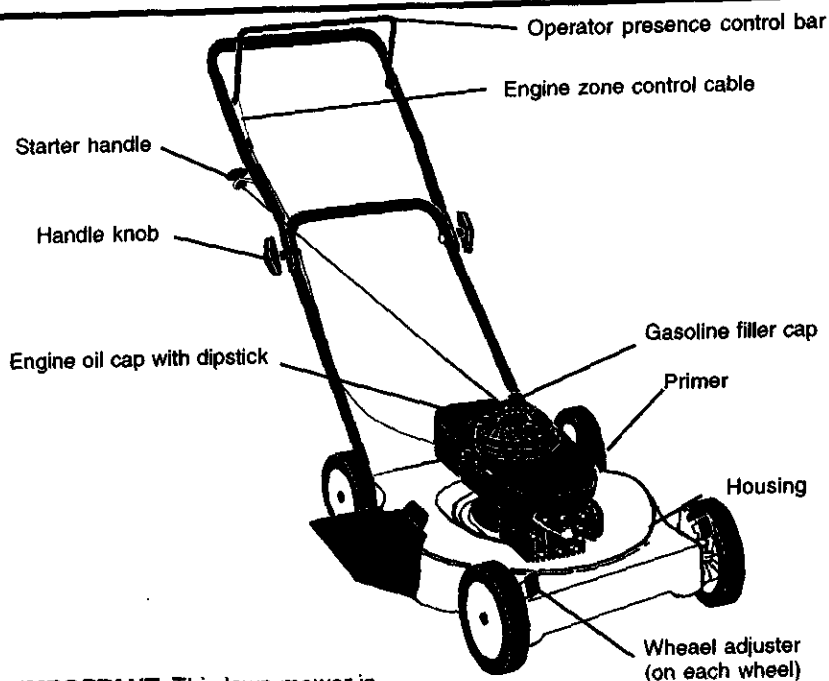
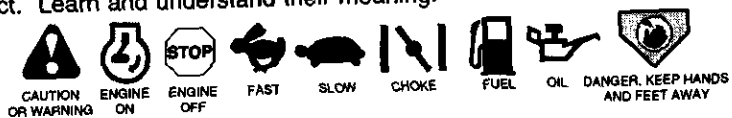

**IMPORTANT:** This lawn mower is shipped without oil or gasoline in the engine.

### MEETS CPSC SAFETY REQUIREMENTS

Sears rotary walk-behind power lawn mowers conform to the safety standards of the American National Standards Institute and the U.S. Consumer Product Safety Commission. The blade turns when the engine is running.

**Operator presence control bar** - must be held down to the handle to start the engine. Release to stop the engine.

**Primer** - pumps additional fuel from the carburetor to the cylinder for use when starting a cold engine.

**Starter handle** - used for starting the engine.



The operation of any lawn mower can result in foreign objects thrown into the eyes, which can result in severe eye damage.

Always wear safety glasses or eye shields while operating your lawn mower or performing any adjustments or repairs. We recommend a wide vision safety mask over spectacles or standard safety glasses.

### HOW TO USE YOUR LAWN MOWER ENGINE SPEED

The engine speed was set at the factory for optimum performance. Speed is not adjustable.

### ENGINE ZONE CONTROL

**CAUTION:** Federal regulations require an engine control to be installed on this lawn mower in order to minimize the risk of blade contact injury. Do not under any circumstances attempt to defeat the function of the operator control. The blade turns when the engine is running.

- Your lawn mower is equipped with an operator presence control bar which requires the operator to be positioned behind the lawn mower handle to start and operate the lawn mower.

### TO ADJUST CUTTING HEIGHT

Raise wheels for low cut and lower wheels for high cut, adjust cutting height to suit your requirements. Medium position is best for most lawns.

- To change cutting height, squeeze adjuster lever toward wheel. Move wheel up or down to suit your requirements. Be sure all wheels are in the same setting.

**NOTE:** Adjuster is properly positioned when plate tab inserts into hole in lever. Also, 9-position adjusters (if so equipped) allow lever to be positioned between the plate tabs.

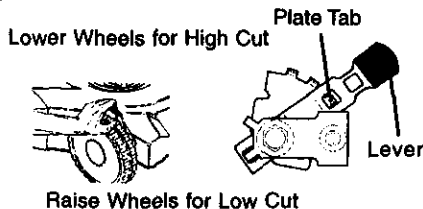

### TO CONVERT TO DISCHARGING MOWER

Your mower is shipped ready to be used as a mulcher. To convert to bagging or discharging:

- Lift discharge guard and remove mulcher plate.
- Mower can now be used for side discharge or optional grass catcher can be attached.
- To return to mulching operation, simply reinstall mulcher plate as shown.

**CAUTION:** Do not run your lawn mower without discharge guard, approved grass catcher or mulcher plate in place.

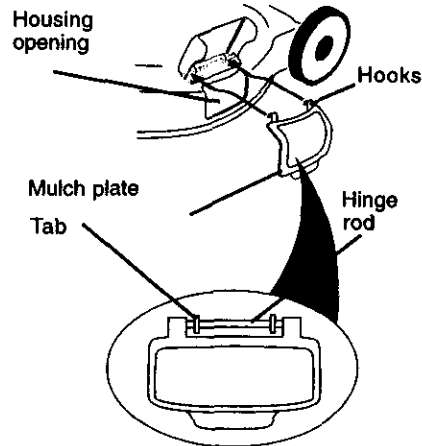

## BEFORE STARTING ENGINE

### ADD OIL

Your lawnmower is shipped without oil in the engine. Engine holds 20 oz. of oil. For type and grade of oil to use, see "ENGINE" in Maintenance section of this manual.

1. Be sure lawnmower is level and area around oil fill is clean.
2. Remove engine oil cap and fill to the full line on the dipstick. Pour oil slowly. Do not over fill.

**NOTE:** Allow oil to settle down into engine for accurate reading. To read proper level, tighten engine oil cap, then remove it to read the dipstick.

3. Reinstall engine oil cap and tighten.
- Check oil level before each use. Add oil if needed. Fill to full line on dipstick.
  - Change the oil after every 25 hours of operation or each season. You may need to change the oil more often under dusty, dirty conditions.

### ADD GASOLINE

- Fill fuel tank. Use fresh, clean, regular unleaded gasoline with a minimum of 87 octane. Do not mix oil with gasoline. Purchase fuel in quantities that can be used within 30 days to assure fuel freshness.

**⚠ WARNING:** Experience indicates that alcohol blended fuels (called gasohol or using ethanol or methanol) can attract moisture which leads to separation and formation of acids during storage. Acidic gas can damage the fuel system of an engine while in storage. To avoid engine problems, the fuel system should be emptied before storage of 30 days or longer. Drain the gas tank, start the engine and let it run until the fuel lines and carburetor are empty. Use fresh fuel next season. See Storage Instructions for additional information. Never use engine or carburetor cleaner products in the fuel tank or permanent damage may occur.

**⚠ CAUTION:** Fill to bottom of gas tank filler neck. Do not overfill. Wipe off any spilled oil or fuel. Do not store, spill or use gasoline near an open flame.

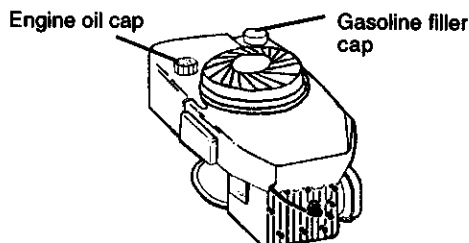

## TO START ENGINE

**NOTE:** Due to protective coatings on the engine, a small amount of smoke may be present during the initial use of the product and should be considered normal.

1. To start a cold engine, push primer three (3) times before trying to start. Use a firm push. This step is not usually necessary when starting an engine which has already run for a few minutes.
2. Hold operator presence control bar down to the handle and pull starter handle quickly. Do not allow starter rope to snap back.

## TO STOP ENGINE

- To stop engine, release operator presence control bar.

**NOTE:** In cooler weather it may be necessary to repeat priming steps. In warmer weather over priming may cause flooding and engine will not start. If you do flood engine, wait a few minutes before attempting to start and do not repeat priming steps.



## MOWING TIPS

- Under certain conditions, such as very tall grass, it may be necessary to raise the height of cut to reduce pushing effort and to keep from overloading the engine and leaving clumps of grass clippings. It may also be necessary to reduce ground speed and/or run the lawn mower over the area a second time.
- For extremely heavy cutting, reduce the width of cut by overlapping previously cut path and mow slowly.
- For better grass bagging and most cutting conditions, the engine speed should be set in the fast position.
- For side discharge lawn mowers, cutting in a counter-clockwise direction, starting at the outside of the area to be cut, spreads grass clippings more evenly and puts less load on the engine. To keep clippings off of walkways, flower beds, etc., make the first cuts in a clockwise direction.
- Pores in cloth grass catchers can become filled with dirt and dust with use and catchers will collect less grass. To prevent this, regularly hose catcher off with water and let dry before using.
- Keep top of engine around starter clear and clean of grass clippings and chaff. This will help engine air flow and extend engine life.

## MULCHING MOWING TIPS

**IMPORTANT:** For best performance, keep mower housing free of built-up grass and trash. See "Cleaning" in MAINTENANCE section of this manual.

- The special mulching blade will recut the grass clippings many times and reduce them in size so that as they fall onto the lawn they will disperse into the grass and not be noticed. Also, the mulched grass will biodegrade quickly to provide nutrients for the lawn. Always mulch with your highest engine (blade) speed as this will provide the best recutting action of the blades.
- Avoid cutting your lawn when it is wet. Wet grass tends to form clumps and interferes with the mulching action. The best time to mow your lawn is the early afternoon. At this time the grass has dried and the newly cut area will not be exposed to the direct sun.
- For best results, adjust the lawn mower cutting height so that the lawn mower cuts off only the top one-third of the grass blades. If the lawn is overgrown it will be necessary to raise the height of cut to reduce pushing effort and to keep from overloading the engine and leaving clumps of mulched grass. For extremely heavy mulching, reduce your width of cut by overlapping previously cut path and mow slowly.
- Certain types of grass and grass conditions may require that an area be mulched a second time to completely hide the clippings. When doing a second cut, mow across or perpendicular to the first cut path.
- Change your cutting pattern from week to week. Mow north to south one week then change to east to west the next week. This will help prevent matting and graining of the lawn.

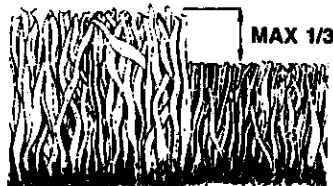

## MAINTENANCE

| <b>MAINTENANCE SCHEDULE</b>                   |   | <div style="display: flex; justify-content: space-around; font-size: small;"> <span>BEFORE EACH USE</span> <span>AFTER EACH USE</span> <span>EVERY 10 HOURS</span> <span>EVERY 25 HOURS OR EVERY SEASON</span> <span>BEFORE STORAGE</span> </div> |   |                |                  |  | SERVICE DATES |  |  |  |  |
|---|---|---|---|----------------|------------------|--|---------------|--|--|--|--|
| FILL IN DATES AS YOU COMPLETE REGULAR SERVICE |   |   |   |                |                  |  |               |  |  |  |  |
| M<br>O<br>W<br>E<br>R                         | Check for Loose Fasteners                         | ✓   |   |                |                  |  |               |  |  |  |  |
|   | Clean/inspect Grass Catcher (if Equipped)         | ✓   | ✓ |                |                  |  |               |  |  |  |  |
|   | Clean Lawn Mower                                  |   | ✓ |                |                  |  |               |  |  |  |  |
|   | Clean Under Drive Cover (Power-Propelled Mowers)  |   |   | ✓              |                  |  |               |  |  |  |  |
|   | Check drive belt/pulleys (Power-Propelled Mowers) |   |   |                | ✓                |  |               |  |  |  |  |
|   | Check/Sharpen/Replace Blade                       |   |   |                | ✓ <sup>3</sup>   |  |               |  |  |  |  |
|   | Lubrication Chart                                 |   |   |                | ✓                |  |               |  |  |  |  |
| E<br>N<br>G<br>I<br>N<br>E                    | Clean Battery/Recharge (Electric Start Mowers)    |   |   |                | ✓                |  |               |  |  |  |  |
|   | Check Engine Oil Level                            | ✓   |   |                |                  |  |               |  |  |  |  |
|   | Change Engine Oil                                 |   |   |                | ✓ <sup>1,2</sup> |  |               |  |  |  |  |
|   | Clean Air Filter                                  |   |   |                | ✓ <sup>2</sup>   |  |               |  |  |  |  |
|   | Inspect Muffler                                   |   |   |                | ✓                |  |               |  |  |  |  |
| Clean or Replace Spark Plug                   |   |   |   | ✓              |                  |  |               |  |  |  |  |
| Replace Air Filter Paper Cartridge            |   |   |   | ✓ <sup>2</sup> |                  |  |               |  |  |  |  |

- 1 - Change more often when operating under a heavy load or in high ambient temperatures.  
 2 - Service more often when operating in dirty or dusty conditions.  
 3 - Replace blades more often when mowing in sandy soil.  
 4 - Charge 48 hours at end of season.

### GENERAL RECOMMENDATIONS

The warranty on this lawn mower does not cover items that have been subjected to operator abuse or negligence. To receive full value from the warranty, operator must maintain mower as instructed in this manual.

Some adjustments will need to be made periodically to properly maintain your unit.

All adjustments in the Service and Adjustments section of this manual should be checked at least once each season.

- Once a year, replace the spark plug, clean or replace air filter element and check blade for wear. A new spark plug and clean/new air filter element assures proper air-fuel mixture and helps your engine run better and last longer.
- Follow the maintenance schedule in this manual.

### BEFORE EACH USE

1. Check engine oil level.
2. Check for loose fasteners.

### LUBRICATION

Keep unit well lubricated (See "LUBRICATION CHART").

### LUBRICATION CHART

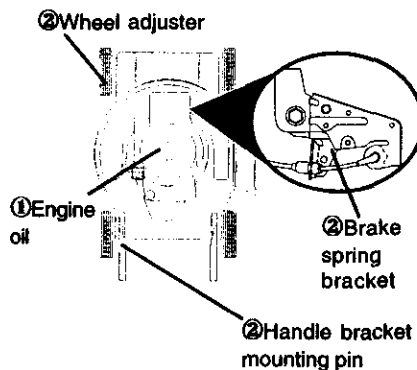

① Refer to maintenance "Engine" section.

② Spray lubricant

**IMPORTANT:** Do not oil or grease plastic wheel bearings. viscous lubricants will attract dust and dirt that will shorten the life of the self-lubricating bearings. if you feel they must be lubricated, use only a dry, powdered graphite type lubricant sparingly.

## PRODUCT SPECIFICATIONS

|   |   |
|---|---|
| SERIAL NUMBER   |   |
| DATE OF PURCHASE  |   |
| GASOLINE CAPACITY/ TYPE:  | 1.5 QUARTS<br>UNLEADED REGULAR                |
| OIL TYPE (API-SF - SJ):   | SAE 30 (ABOVE 32°F)<br>SAE 5W-30 (BELOW 32°F) |
| OIL CAPACITY:   | 20 OZS.                                       |
| SPARK PLUG(GAP: .030")  | CHAMPION RJ19LM OR J19LM                      |
| VALVE CLEARANCE:  | INTAKE: .004 - .008<br>EXHAUST: .004 - .008   |
| SOLID STATE IGNITION  |   |
| AIR GAP:  | .0125 IN.                                     |
| BLADE BOLT TORQUE:  | 35-40 FT. LBS.                                |
| <ul style="list-style-type: none"> <li>The model and serial numbers will be found on a decal attached to the rear of the lawn mower housing. Record both serial number and date of purchase in space provided above.</li> </ul> |   |

### LAWN MOWER

Always observe safety rules when performing any maintenance.

#### TIRES

- Keep tires free of gasoline, oil, or insect control chemicals which can harm rubber.
- Avoid stumps, stones, deep ruts, sharp objects and other hazards that may cause tire damage.

### BLADE CARE

For best results, mower blade must be kept sharp. Replace bent or damaged blades.

#### TO REMOVE BLADE

1. Disconnect spark plug wire from spark plug and place wire where it cannot come in contact with spark plug.
2. Turn lawn mower on its side. Make sure air filter and carburetor are up.
3. Use a wood block between blade and mower housing to prevent blade from turning when removing blade bolt.

**NOTE:** Protect your hands with gloves and/or wrap blade with heavy cloth.

4. Remove blade bolt by turning counter-clockwise.
5. Remove blade and attaching hardware (bolt, lock washer and hardened washer).

**NOTE:** Remove the blade adapter and check the key inside hub of blade adapter. The key must be in good condition to work properly. Replace adapter if damaged.

#### TO REPLACE BLADE

1. Position the blade adapter on the engine crankshaft. Be sure key in adapter and crankshaft keyway are aligned.
  2. Position blade on the blade adapter aligning the two (2) holes in the blade with the raised lugs on the adapter.
  3. Be sure the trailing edge of blade (opposite sharp edge) is up toward the engine.
  4. Install the blade bolt with the lock washer and hardened washer into blade adapter and crankshaft.
  5. Use block of wood between blade and lawn mower housing and tighten the blade bolt, turning clockwise.
- The recommended tightening torque is 35-40 ft. lbs.

**IMPORTANT:** Blade bolt is grade 8 heat treated.

#### TO SHARPEN BLADE

**NOTE:** We do not recommend sharpening blade - but if you do, be sure the blade is balanced.

Care should be taken to keep the blade balanced. An unbalanced blade will cause eventual damage to lawn mower or engine.

- The blade can be sharpened with a file or on a grinding wheel. Do not attempt to sharpen while on the mower.

- To check blade balance, drive a nail into a beam or wall. Leave about one inch of the straight nail exposed. Place center hole of blade over the head of the nail. If blade is balanced, it should remain in a horizontal position. If either end of the blade moves downward, sharpen the heavy end until the blade is balanced.

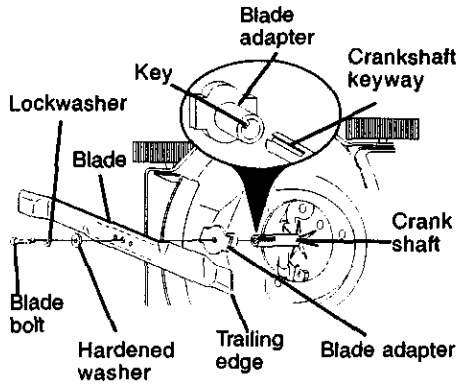

### GRASS CATCHER

- The grass catcher may be hosed with water, but must be dry when used.
- Check your grass catcher often for damage or deterioration. Through normal use it will wear. If catcher needs replacing, replace only with a manufacturer approved replacement catcher. Give the lawn mower model number when ordering.

## ENGINE

### LUBRICATION

Use only high quality detergent oil rated with API service classification SF-SJ. Select the oil's SAE viscosity grade according to your expected operating temperature.

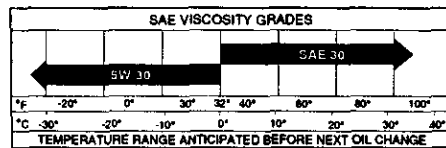

**NOTE:** Although multi-viscosity oils (5W30, 10W30 etc.) improve starting in cold weather, these multi-viscosity oils will result in increased oil consumption when used above 32°F. Check your engine oil level more frequently to avoid possible engine damage from running low on oil.

Change the oil after every 25 hours of operation or at least once a year if the lawn mower is not used for 25 hours in one year.

Check the crankcase oil level before starting the engine and after each five (5) hours of continuous use. Tighten oil plug securely each time you check the oil level.

### TO CHANGE ENGINE OIL

**NOTE:** Before tipping lawn mower to drain oil, drain fuel tank by running engine until fuel tank is empty.

1. Disconnect spark plug wire from spark plug and place wire where it cannot come in contact with spark plug.
2. Remove engine oil cap; lay aside on a clean surface.
3. Tip lawn mower on its side as shown and drain oil into a suitable container. Rock lawn mower back and forth to remove any oil trapped inside of engine.
4. Wipe off any spilled oil on lawn mower and on side of engine.
5. Fill engine with oil. (See "Add Oil" in the Operation section of this manual.)
6. Reconnect spark plug wire to spark plug.

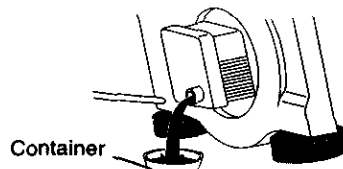

## AIR FILTER

Your engine will not run properly and may be damaged by using a dirty air filter. Replace the air filter every year, more often if you mow in very dusty, dirty conditions. Do not wash air filter.

### TO CHANGE AIR FILTER

1. Remove the air filter by turning counterclockwise to the stop and pull away from collar.
2. Remove filter from inside of cover.
3. Clean the inside of the cover and the collar to remove any dirt accumulation.
4. Insert new filter into cover.
5. Put air filter cover and filter into collar aligning the tab with the slot.
6. Push in on cover and turn clockwise to tighten.

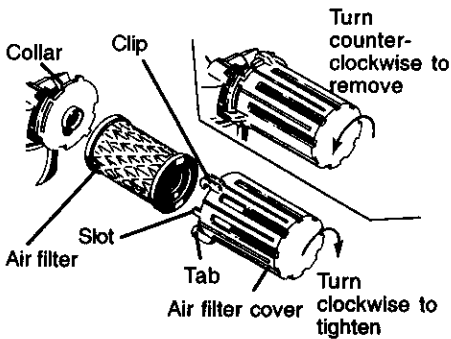

## MUFFLER

Inspect and replace corroded muffler as it could create a fire hazard and/or damage.

## SPARK PLUG

Change your spark plug each year to make your engine start easier and run better. Set spark plug gap at .030 inch.

## CLEANING

**IMPORTANT:** For best performance, keep mower housing free of built-up grass and trash. Clean the underside of your mower after each use.

**CAUTION:** Disconnect spark plug wire from spark plug and place wire where it cannot come in contact with the spark plug.

- Clean the underside of your lawn mower by scraping to remove build-up of grass and trash.
- Clean engine often to keep trash from accumulating. A clogged engine runs hotter and shortens engine life.
- Keep finished surfaces and wheels free of all gasoline, oil, etc.
- We do not recommend using a garden hose to clean lawn mower unless the electrical system, muffler, air filter and carburetor are covered to keep water out. Water in engine can result in shortened engine life.

## SERVICE AND ADJUSTMENTS

**CAUTION:** Before performing any service or adjustments:

1. Release control bar and stop engine.
2. Make sure the blade and all moving parts have completely stopped.
3. Disconnect spark plug wire from spark plug and place where it cannot come in contact with plug.

### LAWN MOWER

#### TO ADJUST CUTTING HEIGHT

See "TO ADJUST CUTTING HEIGHT" in the Operation section of this manual.

#### REAR DEFLECTOR

The rear deflector, attached between the rear wheels of your mower, is provided to minimize the possibility that objects will be thrown out of the rear of the mower into the operator's mowing position. If the deflector becomes damaged, it should be replaced.

#### DISCHARGE GUARD

The discharge guard, attached to the discharge opening of your lawn mower, is provided to prevent the possibility of injury resulting from objects being thrown out of the discharge opening into the operator mowing position. If the discharge guard becomes damaged, it should be replaced.

#### TO ADJUST HANDLE

The handle can be mounted in a high or low position. The mounting holes in the bottom of lower handle are off center for raising or lowering the handle.

1. Remove upper handle and all parts attached to lower handle.
2. Remove hairpin cotters from lower handle bracket mounting pin.
3. Squeeze lower handle in to remove it from mounting pins.
4. Turn lower handle over to raise or lower handle.
5. Squeeze lower handle in and position holes onto mounting pins on handle bracket.
6. Reassemble upper handle and all parts removed from lower handle.

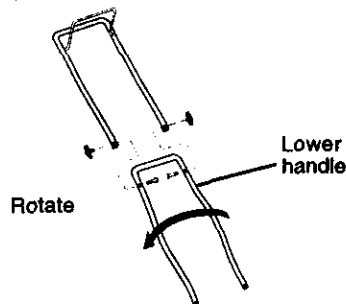

### ENGINE

#### ENGINE SPEED

Your engine speed has been factory set. Do not attempt to increase engine speed or it may result in personal injury. If you believe that the engine is running too fast or too slow, take your lawn mower to an authorized service center for repair and adjustment.

#### CARBURETOR

Your carburetor has a non-adjustable fixed main jet for mixture control. If your engine does not operate properly due to suspected carburetor problems, take your lawn mower to an authorized service center for repair and/or adjustment.

**IMPORTANT:** Never tamper with the engine governor, which is factory set for proper engine speed. Overspeeding the engine above the factory high speed setting can be dangerous. If you think the engine-governed high speed needs adjusting, contact your nearest authorized service center, which has proper equipment and experience to make any necessary adjustments.

## STORAGE

Immediately prepare your lawn mower for storage at the end of the season or if the unit will not be used for 30 days or more.

### LAWN MOWER

When lawn mower is to be stored for a period of time, clean it thoroughly, remove all dirt, grease, leaves, etc. Store in a clean, dry area.

1. Clean entire lawn mower (See "CLEANING" in the Maintenance section of this manual).
2. Lubricate as shown in the Maintenance section of this manual.
3. Be sure that all nuts, bolts, screws, and pins are securely fastened. Inspect moving parts for damage, breakage and wear. Replace if necessary.
4. Touch up all rusted or chipped paint surfaces; sand lightly before painting.

### HANDLE

You can fold your lawn mower handle for storage.

1. Squeeze the bottom ends of the lower handle toward each other until the lower handle clears the handle bracket, then move handle forward.
2. Loosen upper handle mounting bolts enough to allow upper handle to be folded back.

**IMPORTANT:** When folding the handle for storage or transportation, be sure to fold the handle as shown or you may damage the control cables.

- When setting up your handle from the storage position, the lower handle will automatically lock into the mowing position.

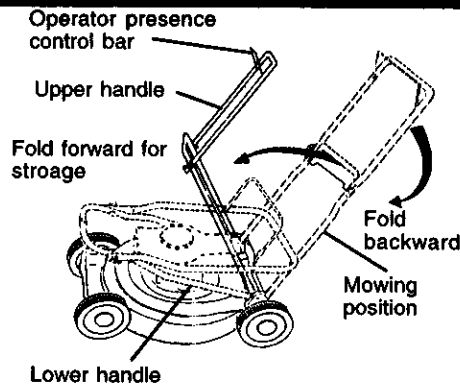
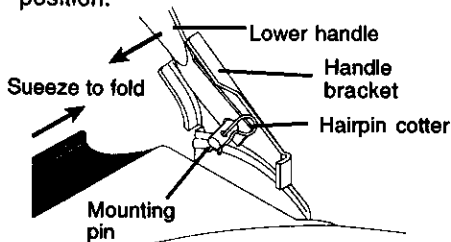

### ENGINE

#### FUEL SYSTEM

**IMPORTANT:** It is important to prevent gum deposits from forming in essential fuel system parts such as carburetor, fuel filter, fuel hose, or tank during storage. Also, experience indicates that alcohol blended fuels (called gasohol or using ethanol or methanol) can attract moisture which leads to separation and formation of acids during storage. Acidic gas can damage the fuel system of an engine while in storage.

1. Drain the fuel tank.
  2. Start the engine and let it run until the fuel lines and carburetor are empty.
- Never use engine or carburetor cleaner products in the fuel tank or permanent damage may occur.
  - Use fresh fuel next season.

**NOTE:** Fuel stabilizer is an acceptable alternative in minimizing the formation of fuel gum deposits during storage. Add stabilizer to gasoline in fuel tank or storage container. Always follow the mix ratio found on stabilizer container. Run engine at least 10 minutes after adding stabilizer to allow the stabilizer to reach the carburetor. Do not drain the gas tank and carburetor if using fuel stabilizer.

#### ENGINE OIL

Drain oil (with engine warm) and replace with clean engine oil. (See "ENGINE" in the Maintenance section of this manual).

#### CYLINDER

1. Remove spark plug.
2. Pour one ounce (29 ml) of oil through spark plug hole into cylinder.
3. Pull starter handle slowly a few times to distribute oil.
4. Replace with new spark plug.

**OTHER**

- Do not store gasoline from one season to another.
- Replace your gasoline can if your can starts to rust. Rust and/or dirt in your gasoline will cause problems.
- If possible, store your unit indoors and cover it to give protection from dust and dirt.

- Cover your unit with a suitable protective cover that does not retain moisture. Do not use plastic. Plastic cannot breathe which allows condensation to form and will cause your unit to rust.
- IMPORTANT:** Never cover mower while engine and exhaust areas are still warm.
- CAUTION:** Never store the lawn mower with gasoline in the tank inside a building where fumes may reach an open flame or spark. Allow the engine to cool before storing in any enclosure.

**TROUBLESHOOTING CHART**

| PROBLEM                    | CAUSE   | CORRECTION   |
|----------------------------|---|--|
| <b>Does not start</b>      | <ol style="list-style-type: none"> <li>1. Dirty air filter.</li> <li>2. Out of fuel.</li> <li>3. Stale fuel.</li> <li>4. Water in fuel.</li> <li>5. Spark plug wire is disconnected.</li> <li>6. Bad spark plug.</li> <li>7. Loose blade or broken blade adapter.</li> <li>8. Control bar in released position.</li> <li>9. Control bar defective.</li> </ol> | <ol style="list-style-type: none"> <li>1. Clean/replace air filter.</li> <li>2. Fill fuel tank.</li> <li>3. Drain tank and refill with fresh clean fuel.</li> <li>4. Drain fuel tank and carburetor and refill tank with fresh gasoline.</li> <li>5. Connect wire to plug.</li> <li>6. Replace spark plug.</li> <li>7. Tighten blade bolt or replace blade adapter.</li> <li>8. Depress control bar to handle.</li> <li>9. Replace control bar.</li> </ol> |
| <b>Loss of power</b>       | <ol style="list-style-type: none"> <li>1. Rear of lawn mower housing or cutting blade dragging in heavy grass.</li> <li>2. Cutting too much grass.</li> <li>3. Dirty air filter.</li> <li>4. Buildup of grass, leaves, and trash under mower.</li> <li>5. Too much oil in engine.</li> <li>6. Walking speed too fast.</li> </ol>                              | <ol style="list-style-type: none"> <li>1. Set to "Higher Cut" position.</li> <li>2. Set to "Higher Cut" position.</li> <li>3. Clean/replace air filter.</li> <li>4. Clean underside of mower housing.</li> <li>5. Check oil level.</li> <li>6. Cut at slower walking speed.</li> </ol>   |
| <b>Poor cut – uneven</b>   | <ol style="list-style-type: none"> <li>1. Worn, bent or loose blade.</li> <li>2. Wheel heights uneven.</li> <li>3. Buildup of grass, leaves and trash under mower.</li> </ol>   | <ol style="list-style-type: none"> <li>1. Replace blade. Tighten blade bolt.</li> <li>2. Set all wheels at same height</li> <li>3. Clean underside of mower housing.</li> </ol>  |
| <b>Excessive vibration</b> | <ol style="list-style-type: none"> <li>1. Worn, bent or loose blade.</li> <li>2. Bent engine crankshaft.</li> </ol>   | <ol style="list-style-type: none"> <li>1. Replace blade. Tighten blade bolt.</li> <li>2. Contact a Sears or other qualified service center.</li> </ol>   |



**TROUBLESHOOTING CHART**

| <b>PROBLEM</b>                                    | <b>CAUSE</b>   | <b>CORRECTION</b>   |
|---|--|---|
| <b>Starter rope hard to pull</b>                  | <ol style="list-style-type: none"><li>1. Engine flywheel brake is on when control bar is released.</li><li>2. Bent engine crankshaft.</li><li>3. Blade adapter broken.</li><li>4. Blade dragging in grass.</li></ol>                                       | <ol style="list-style-type: none"><li>1. Depress control bar to upper handle before pulling starter rope.</li><li>2. Contact a Sears or other qualified service center.</li><li>3. Replace blade adapter.</li><li>4. Move lawn mower to cut grass or to hard surface.</li></ol> |
| <b>Grass catcher not filling (if so equipped)</b> | <ol style="list-style-type: none"><li>1. Cutting height too low.</li><li>2. Lift on blade worn off.</li><li>3. Catcher not venting air.</li></ol>  | <ol style="list-style-type: none"><li>1. Raise cutting height.</li><li>2. Replace blade.</li><li>3. Clean grass catcher.</li></ol>  |
| <b>Hard to push</b>                               | <ol style="list-style-type: none"><li>1. Grass is too high or wheel height is too low.</li><li>2. Rear of lawn mower housing or blade dragging in grass.</li><li>3. Grass catcher too full.</li><li>4. Handle height position not right for you.</li></ol> | <ol style="list-style-type: none"><li>1. Raise cutting height.</li><li>2. Raise rear of lawn mower housing one (1) setting higher.</li><li>3. Empty grass catcher.</li><li>4. Adjust handle height to suit.</li></ol>   |

ROTARY LAWN MOWER - MODEL NO. 917.388223

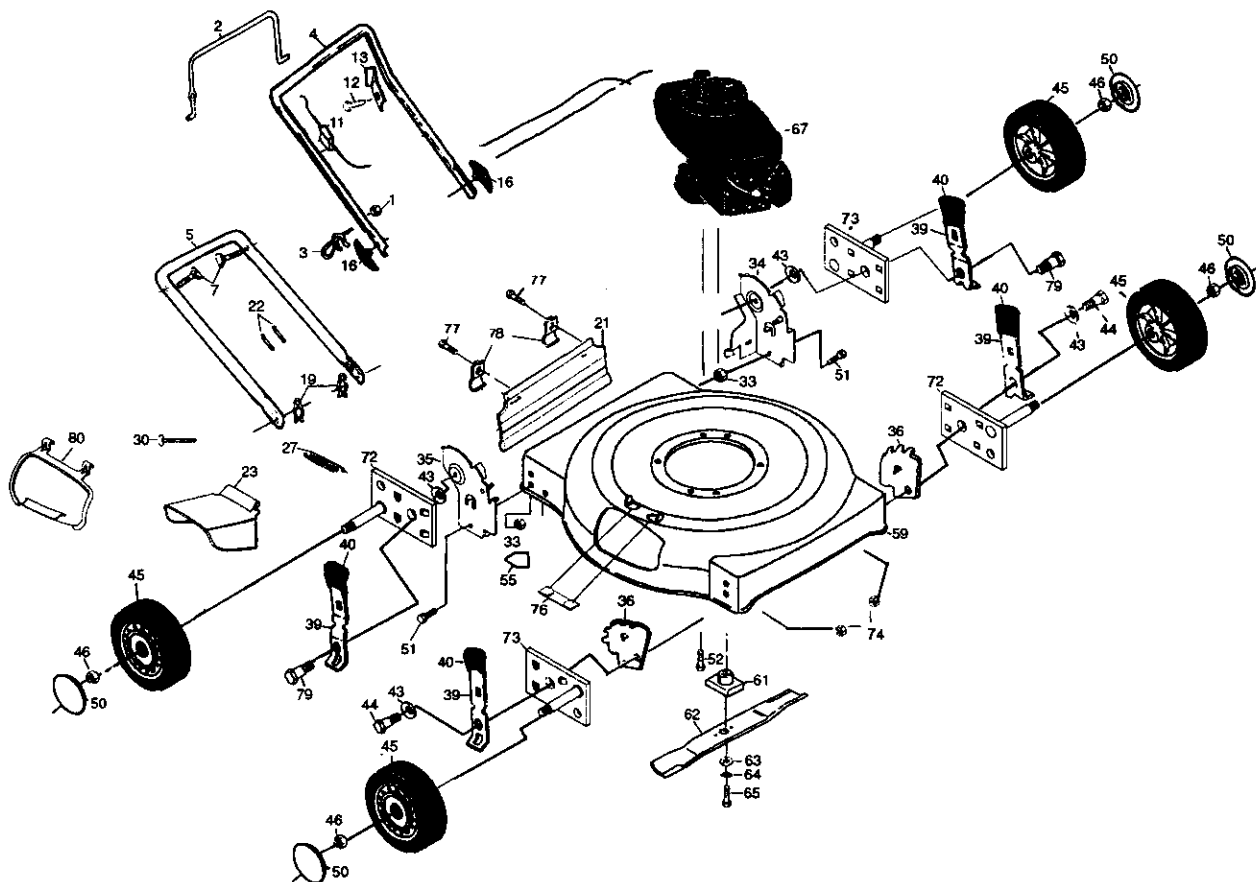

REPAIR PARTS

## ROTARY LAWN MOWER - MODEL NO. 917.388223

| KEY NO. | PART NO    | DESCRIPTION                          | KEY NO. | PART NO    | DESCRIPTION  |
|---------|------------|--------------------------------------|---------|------------|--|
| 1       | 63601      | Locknut 1/4-20                       | 50      | 77400      | Hubcap   |
| 2       | 86902      | Control Bar                          | 51      | 17600406   | Screw Hex serrated 1/4 x 20 tt                           |
| 3       | 132001     | Rope Guide                           | 52      | 150406     | Hex Head Thread Rolling Screw 3/8-16 x 1                 |
| 4       | 169709X479 | Upper Handle                         | 55      | 85463      | Danger Decal   |
| 5       | 169708X479 | Lower Handle                         | 59      | 161345     | Lawn Mower Housing ( Incl. Key No. 55)                   |
| 7       | 131959     | Handle Bolt 5/16-18                  | 61      | 851514     | Blade Adapter  |
| 11      | 168552     | Engine Zone Control Cable            | 62      | 141114     | 22" Blade  |
| 12      | 750097     | Hex Thread Rolling Screw #10-24 x1/2 | 63      | 851074     | Hardened Washer  |
| 13      | 850733X004 | Up-Stop Bracket                      | 64      | 850263     | Helical Lockwasher 3/8                                   |
| 16      | 136376     | Handle Knob                          | 65      | 851084     | Hex Head Screw 3/8-24 x 1/4 Grd. 8                       |
| 19      | 51793      | Hairpin Cotter                       | 67      | -----      | Engine - ( See Breakdown) Craftsman Model No. 143.004502 |
| 21      | 165858     | Rear Deflector                       | 72      | 167132X004 | Axle Arm Asm. (RR/LF)                                    |
| 22      | 66426      | Wire Tie                             | 73      | 167133X004 | Axle Arm Asm (RF/LR)                                     |
| 23      | 160831     | Discharge Guard                      | 74      | 751153     | Nut  |
| 27      | 160832     | Torsion Spring                       | 76      | 161622     | Clip, Closeout   |
| 30      | 160833     | Hinge Rod                            | 77      | 750097     | Screw  |
| 33      | 751153     | Nut Hex Flange Lock 5/16-18          | 78      | 87584X004  | Hinge Bracket  |
| 34      | 168164X479 | Wheel Bracket Support (Left)         | 79      | 160828     | Shouldr Bolt 5/16-18 x .51                               |
| 35      | 168165X479 | Wheel Bracket Support (Right)        | 80      | 160830     | Mulcher Plate  |
| 36      | 160835x007 | Wheel Bracket Adjuster               | --      | 175411     | Owner's Manual (English/Spanish)                         |
| 39      | 168360X004 | Selector Spring                      | --      | 161058     | Warning Decal (Not Shown)                                |
| 40      | 87877      | Selector Knob                        |         |            |  |
| 43      | 19112222   | Washer                               |         |            |  |
| 44      | 160828     | Shoulder Bolt                        |         |            |  |
| 45      | 146248     | Wheel Assembly                       |         |            |  |
| 46      | 83923      | Locknut 1/16-18                      |         |            |  |
|         |            |                                      |         |            | Available accessories not included with lawn mower:      |
|         |            |                                      | 71      | 33000      | SAE 30W Oil (20 oz.)                                     |

**CRAFTSMAN 4-CYCLE ENGINE**

**MODEL NUMBER 143.004502**

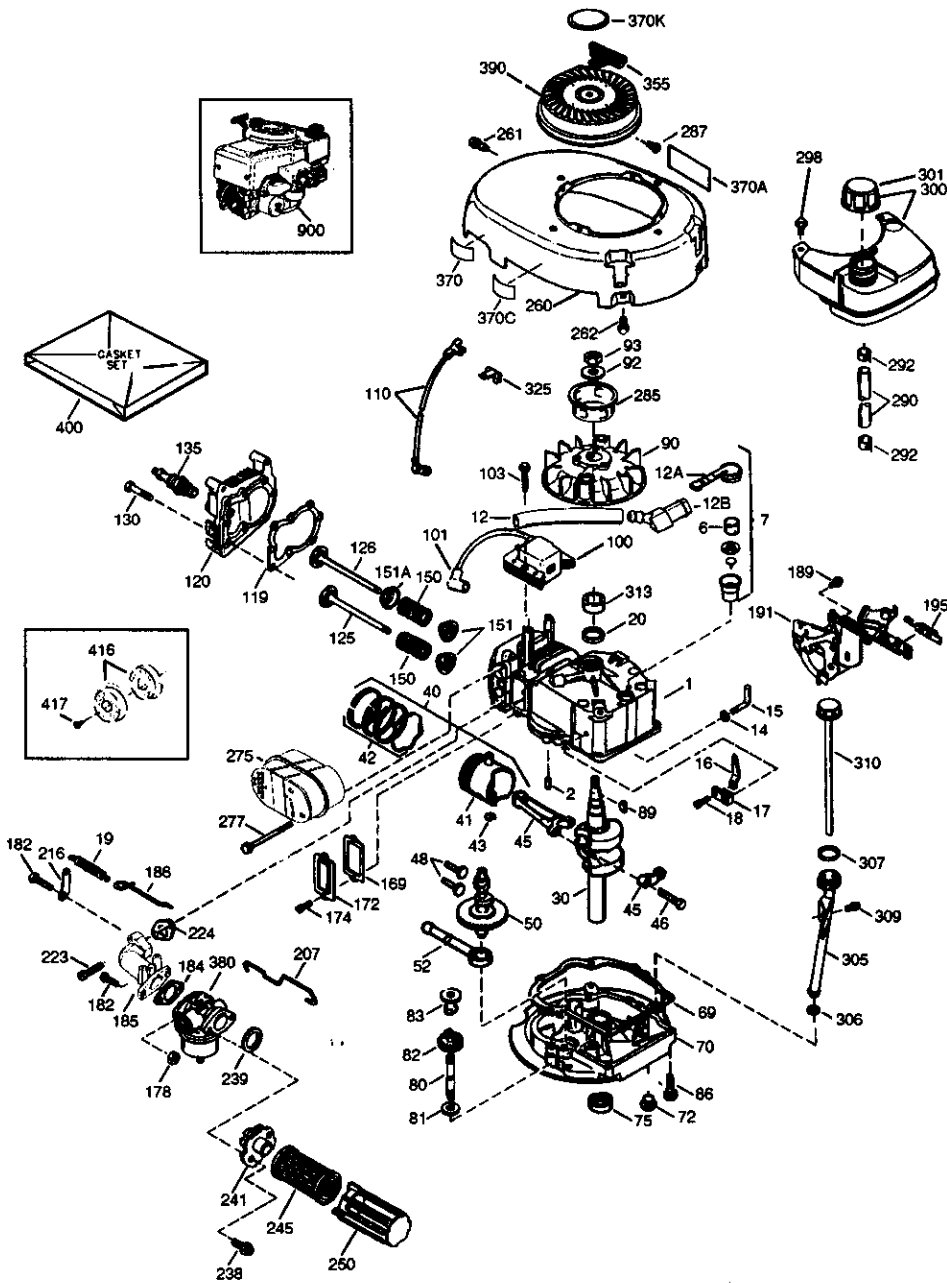

**CRAFTSMAN 4-CYCLE ENGINE**

**MODEL NUMBER 143.004502**

| KEY PART NO. | PART NO. | DESCRIPTION                               | KEY PART NO. | PART NO. | DESCRIPTION   |
|--------------|----------|---|--------------|----------|---|
| 1            | 37280    | Cylinder (Incl. 2,20 & 150)               | 172          | 36784    | Valve Cover   |
| 2            | 26727    | Dowel Pin                                 | 174          | 30200    | Screw, 10-24 x 9/16"  |
| 6            | 33734    | Breather Element                          | 178          | 29752    | Nut & Lock Washer, 1/4-28   |
| 7            | 36557    | Breather Ass'y. (Incl. 6 & 12A)           | 182          | 6201     | Screw, 1/4-28 x 7/8"  |
| 12           | 36775    | Breather Tube                             | 184          | 26756    | Carburetor To Intake Pipe Gasket  |
| 12A          | 36558    | Breather Cover & Tube (Incl. 12B)         | 185          | 36785    | Intake Pipe   |
| 12B          | 36694    | Breather Tube Elbow                       | 186          | 32653    | Governor Link   |
| 14           | 28277    | Washer                                    | 189          | 650839   | Screw, 1/4-20 x 3/8"  |
| 15           | 30589    | Governor Rod (Incl. 14)                   | 191          | 36559A   | S.E. Brake Bracket (Incl. 195)  |
| 16           | 34839A   | Governor Lever                            | 195          | 610973   | Terminal  |
| 17           | 31335    | Governor Lever Clamp                      | 207          | 34336    | Throttle Link   |
| 18           | 651018   | Screw, Torx T-15, 8-32 x 19/64"           | 216          | 33086    | R.P.M. Adjusting Lever  |
| 19           | 36281    | Extension Spring                          | 223          | 650451   | Screw, 1/4-20 x 1"  |
| 20           | 32600    | Oil Seal                                  | 224          | 36786    | Intake Pipe Gasket  |
| 30           | 36776    | Crankshaft                                | 238          | 650932   | Screw, 10-32 x 49/64"   |
| 40           | 35544A   | Piston, Pin & Ring Set (Std.)             | 239          | 34338    | Air Cleaner Gasket  |
|              | 35545A   | Piston, Pin & Ring Set (.010" OS)         | 241          | 35797    | Air Cleaner Collar  |
|              | 35546    | Piston, Pin & Ring Set (.020" OS)         | 245          | 35066    | Air Cleaner Filter  |
| 41           | 35541    | Piston & Pin Ass'y. (Std.) (Incl. 43)     | 250          | 35065    | Air Cleaner Cover   |
|              | 35542    | Piston & Pin Ass'y. (.010" OS) (Incl. 43) | 260          | 36980    | Blower Housing  |
|              | 35543    | Piston & Pin Ass'y. (.020" OS) (Incl. 43) | 261          | 30200    | Screw, 10-24 x 9/16"  |
| 42           | 35547A   | Ring Set (Std.)                           | 262          | 650831   | Screw, 1/4-20 x 1/2"  |
|              | 35548A   | Ring Set (.010" OS)                       | 275          | 36790A   | Muffler   |
|              | 35549    | Ring Set (.020" OS)                       | 277          | 650988   | Screw, 1/4-20 x 2-5/16"   |
| 43           | 20381    | Piston Pin Retaining Ring                 | 285          | 35000A   | Starter Cup   |
| 45           | 36777    | Connecting Rod Ass'y. (Incl. 46)          | 287          | 650926   | Screw, 8-32 x 21/64"  |
| 46           | 32610A   | Connecting Rod Bolt                       | 290          | 29774    | Fuel Line   |
| 48           | 27241    | Valve Lifter                              | 292          | 26460    | Fuel Line Clamp   |
| 50           | 37032    | Camshaft (NCR)                            | 298          | 28763    | Screw, 10-32 x 35/64"   |
| 52           | 29914    | Oil Pump Ass'y.                           | 300          | 36916    | Fuel Tank (Incl. 292 & 301)   |
| 69           | 35261    | Mounting Flange Gasket                    | 301          | 36246    | Fuel Cap  |
| 70           | 34311E   | Mounting Flange (Incl. 72 thru 83,306)    | 305          | 35647    | Oil Fill Tube   |
| 72           | 36083    | Oil Drain Plug                            | 306          | 36996    | "O"-Ring  |
| 75           | 27897    | Oil Seal                                  | 307          | 35499    | "O"-Ring  |
| 80           | 30574A   | Governor Shaft                            | 309          | 650562   | Screw, 10-32 x 1/2"   |
| 81           | 30590A   | Washer                                    | 310          | 35648    | Dipstick  |
| 82           | 30591    | Governor Gear Ass'y. (Incl. 81)           | 313          | 34080    | Spacer  |
| 83           | 30588A   | Governor Spool                            | 325          | 37152    | Spring Clip   |
| 86           | 650488   | Screw, 1/4-20 x 1-1/4"                    | 355          | 590701   | Starter Handle  |
| 89           | 611004   | Flywheel Key                              | 370A         | 36261    | Lubrication Decal (Replaces 64-831)   |
| 90           | 611112   | Flywheel                                  | 370C         | 37318    | Primer Decal (3 X)  |
| 92           | 650815   | Belleville Washer                         | 370K         | 36695    | Starter Decal   |
| 93           | 650816   | Flywheel Nut                              | 370R         | 37317    | Hot Surface Decal   |
| 100          | 34443B   | Solid State Ignition                      | 380          | 640262   | Carburetor (Incl. 184)  |
| 101          | 610118   | Spark Plug Cover                          | 390          | 590737   | Rewind Starter  |
| 103          | 651007   | Screw, Torx T-15, 10-24 x 15/16"          | 400          | 37029A   | Gasket Set (Incl. Items Marked*)  |
| 110          | 37047    | Ground Wire                               | 416          | 36085    | Spark Arrestor Kit (Incl. 417)(Optional)                                    |
| 119          | 37028    | Cylinder Head Gasket                      | 417          | 650821   | Screw, 10-32 x 1/2" (Optional)  |
| 120          | 36825    | Cylinder Head                             | 900          | ---      | Replacement Engine 750830, (Not Available in California), order from 71-999 |
| 125          | 37288    | Exhaust Valve (Std.) (Incl. 151)          | 900          | ---      | Replacement Short Block 750806B, order from 71-999                          |
| 126          | 37289    | Intake Valve (Std.) (Incl. 151)           | ---          | ---      | RPM High 2900 to 3200   |
| 130          | 6021A    | Screw, 5/16-18 x 1-1/2"                   |              |          |   |
| 135          | 35395    | Resistor Spark Plug (RJ19LM)              |              |          |   |
| 150          | 31672    | Valve Spring                              |              |          |   |
| 151          | 31673    | Valve Spring Cap                          |              |          |   |
| 151A         | 40017    | Intake Valve Seal                         |              |          |   |
| 169          | 36783    | Valve Cover Gasket                        |              |          |   |

**NOTE:** This engine could have been built with 590694 starter).  
**NOTE:** All component dimensions given in U.S. inches 1 inch = 25.4 mm

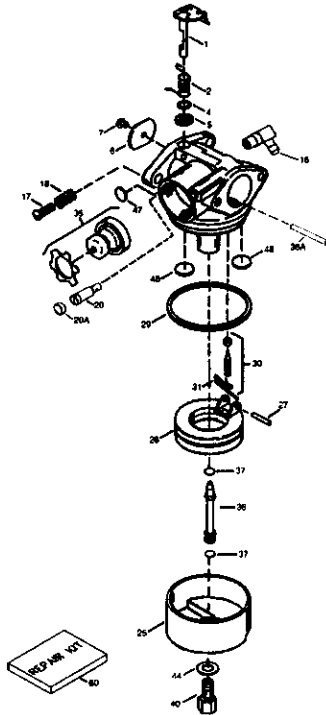

| KEY PART NO. | NO.      | DESCRIPTION                                 |
|--------------|----------|---|
| —            | 640262   | Carburetor (Incl. 184 of Engine Parts List) |
| 1            | 631615   | Throttle Shaft & Lever Assembly             |
| 2            | 631767   | Throttle Return Spring                      |
| 4            | 631184 * | Dust Seal Washer                            |
| 5            | 631183 * | Dust Seal (Throttle)                        |
| 6            | 640070   | Throttle Shutter                            |
| 7            | 650506 * | Shutter Screw                               |
| 16           | 631807   | Fuel Fitting                                |
| 17           | 651025   | Throttle Crack Screw/Idle Speed Screw       |
| 18           | 630766   | Tension Spring                              |
| 20           | 640018   | Idle Restrictor Screw                       |
| 20A          | 640200   | Idle Restrictor Screw Cap (Black)           |
| 25           | 631867   | Float Bowl                                  |
| 27           | 631024 * | Float Shaft                                 |
| 28           | 632019   | Float                                       |
| 29           | 631028 * | Float Bowl "O" Ring                         |
| 30           | 631021 * | Inlet Needle, Seat, & Clip (Incl. 31)       |
| 31           | 631022   | Spring Clip                                 |
| 35           | 640259   | Primer Bulb/Retainer Ring                   |
| 36           | 640080   | Main Nozzle Tube                            |
| 36A          | 632766   | Carburetor Tube                             |
| 37           | 632547 * | "O" Ring, Main Nozzle Tube                  |
| 40           | 640175   | High Speed Bowl Nut                         |
| 44           | 27110A * | Bowl Nut Washer                             |
| 47           | 630748 * | Welch Plug, Idle Mixture Well               |
| 48           | 631027 * | Welch Plug, Atmospheric Vent                |
| 60           | 632760B  | Repair kit (Incl. Items Marked *)           |

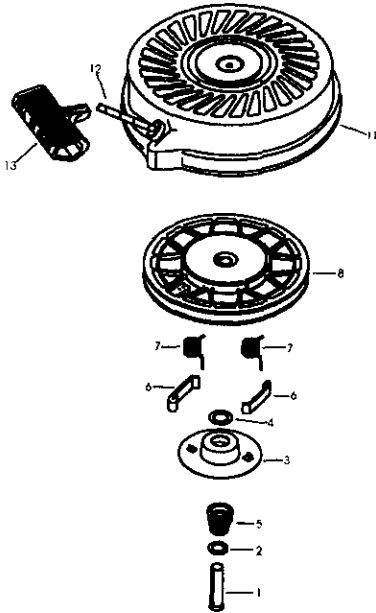

| KEY PART NO. | PART NO. | DESCRIPTION                                |
|--------------|----------|--|
| —            | 590694   | Recoil Starter                             |
| 1            | 590599A  | Spring Pin (Incl. 4)                       |
| 2            | 590600   | Washer                                     |
| 3            | 590696   | Retainer                                   |
| 4            | 590601   | Washer                                     |
| 5            | 590697   | Brake Spring                               |
| 6            | 590698   | Starter Dog                                |
| 7            | 590699   | Dog Spring                                 |
| 8            | 590700   | Pulley & Rewind Spring Ass'y.              |
| 11           | 590695   | Starter Housing Ass'y. (40 degree grommet) |
| 12           | 590535   | Starter Rope ( 98" X 9/64" dia.)           |
| 13           | 590701   | Starter Handle                             |

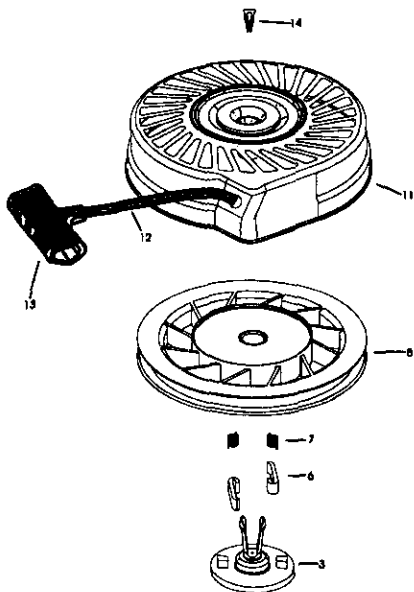

| KEY PART NO. | PART NO. | DESCRIPTION                               |
|--------------|----------|---|
| —            | 590737   | Rewind Starter                            |
| 3            | 590740   | Retainer                                  |
| 6            | 590616   | Starter Dog                               |
| 7            | 590617   | Dog Spring                                |
| 8            | 590618A  | Pulley & Rewind Spring Ass'y              |
| 11           | 590687A  | Starter Housing Ass'y (40 degree grommet) |
| 12           | 590535   | Starter Rope (Length 98" x 9/64" dia.)    |
| 13           | 590701   | Starter Handle                            |
| 14           | 590760   | Spring Clip                               |

# Get it fixed, at your home or ours!

For repair of major brand appliances **in your own home...**  
no matter who made it, no matter who sold it!

**1-800-4-MY-HOME**<sup>SM</sup> Anytime, day or night  
(1-800-469-4663)

[www.sears.com](http://www.sears.com)

To bring in products such as vacuums,  
lawn equipment and electronics for repair, call for  
the location of your nearest **Sears Parts & Repair Center.**

**1-800-488-1222** Anytime, day or night

[www.sears.com](http://www.sears.com)

For the replacement parts, accessories and owner's manuals  
that you need to do-it-yourself, call **Sears PartsDirect**<sup>SM</sup>!

**1-800-366-PART** 6 a.m. – 11 p.m. CST,  
(1-800-366-7278) 7 days a week

[www.sears.com/partsdirect](http://www.sears.com/partsdirect)

To purchase or inquire about a Sears Service Agreement:

**1-800-827-6655**

7 a.m. – 5 p.m. CST, Mon. – Sat.

Para pedir servicio de reparación a domicilio,  
y para ordenar piezas con entrega a domicilio:

**1-888-SU-HOGAR**<sup>SM</sup>  
(1-888-784-6427)

Au Canada pour service en français:

**1-877-LE-FOYER**<sup>SM</sup>  
(1-877-533-6937)



© Sears, Roebuck and Co.

® Registered Trademark / ™ Trademark of Sears, Roebuck and Co.  
® Marca Registrada / ™ Marca de Fábrica de Sears, Roebuck and Co.