

Owner's Manual

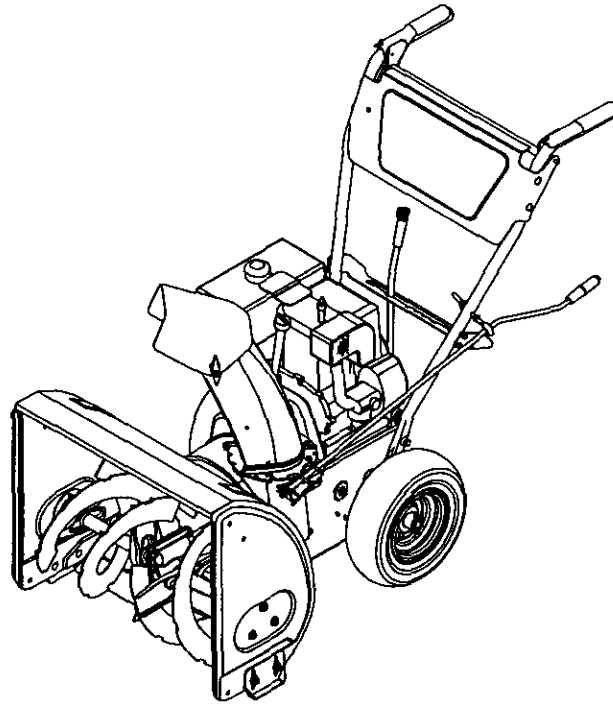

5.0 Horse Power 24" Two-Stage Wheel Drive Snow Thrower

Model No.
247.886640



CAUTION: Before using this product, read this manual and follow all safety rules and operating instructions.

- Safety
- Assembly
- Operation
- Service
- Maintenance
- Español

Sears, Roebuck And Co., Hoffman Estates, IL 60179, U.S.A.

Visit our website: www.sears.com/craftsman

PRINTED IN U.S.A.

FORM NO.770-10433
(8/2000)

TABLE OF CONTENTS

Content	Page	Content	Page
Warranty Information	2	Service & Adjustment.....	15
Safe Operation Practices	3	Off-Season Storage	19
Hardware Pack	5	Trouble-Shooting	20
Assembly	6	Parts List.....	21
Operation	10	Espanol.....	34
Maintenance	13		

WARRANTY INFORMATION

Two -Year Warranty on Craftsman Snow Thrower

For two years from the date of purchase, when this Craftsman Snow Thrower is maintained, lubricated and tuned up according to the instructions in the owner's manual, Sears will repair, free of charge, any defect in material and workmanship.

If this Craftsman snow thrower is used for commercial or rental purposes, this warranty applies for only 30 days from the date of purchase.

This warranty does not cover:

Expendable items which become worn during normal use, such as skid shoes, shave plate and spark plugs.

Repairs necessary because of operator abuse or negligence, including bent crankshafts and the failure to maintain the equipment according to the instructions contained in the owner's manual.

WARRANTY SERVICE IS AVAILABLE BY RETURNING THE CRAFTSMAN SNOW THROWER TO THE NEAREST SEARS SERVICE CENTER/DEPARTMENT IN THE UNITED STATES.

This warranty applies only while this product is in use in the United States.

This warranty gives you specific legal rights and you may also have other rights which may vary from state to state.

SEARS, ROEBUCK AND CO., D/817WA, HOFFMAN ESTATES, IL 60179

PRODUCT SPECIFICATIONS

Horsepower:	5.0
Engine Oil	SAE 5W30 oil
Spark Plug:	RJ-19LM
Engine:.....	143.015007

MODEL NUMBER

Model Number	247.886640
Serial Number.....
Date of Purchase
Record both serial number and date of purchase and keep in a safe place for future reference.	

IMPORTANT SAFE OPERATION PRACTICES



This symbol points out important safety instructions which, if not followed, could endanger the personal safety and/or property of yourself and others. Read and follow all instructions in this manual before attempting to operate this machine. Failure to comply with these instructions may result in personal injury. When you see this symbol—**heed its warning.**



WARNING: Engine Exhaust, some of its constituents, and certain vehicle components contain or emit chemicals known to State of California to cause cancer and birth defects or other reproductive harm.



DANGER: This machine was built to be operated according to the rules for safe operation in this manual. As with any type of power equipment, carelessness or error on the part of the operator can result in serious injury. This machine is capable of amputating hands and feet and throwing objects. Failure to observe the following safety instructions could result in serious injury or death.

Training

1. Read, understand, and follow all instructions on the machine and in the manual(s) before attempting to assemble and operate. Keep this manual in a safe place for future and regular reference and for ordering replacement parts.
2. Be familiar with all controls and their proper operation. Know how to stop the machine and disengage them quickly.
3. Never allow children under 14 years old to operate this machine. Children 14 years old and over should read and understand the operation instructions and safety rules in this manual and should be trained and supervised by a parent.
4. Never allow adults to operate this machine without proper instruction.
5. Thrown objects can cause serious personal injury. Plan your snow throwing pattern to avoid discharge of material toward roads, bystanders and the like.
6. Keep bystanders, helpers, pets and children at least 75 feet from the machine while it is in operation. Stop machine if anyone enters the area.
7. Exercise caution to avoid slipping or falling, especially when operating in reverse.
8. Let engine and machine adjust to outdoor temperature before starting to clear snow.
9. To avoid personal injury or property damage use extreme care in handling gasoline. Gasoline is extremely flammable and the vapors are explosive. Serious personal injury can occur when gasoline is spilled on yourself or your clothes which can ignite. Wash your skin and change clothes immediately.
 - a. Use only an approved gasoline container.
 - b. Extinguish all cigarettes, cigars, pipes and other sources of ignition.
 - c. Never fuel machine indoors.
 - d. Never remove gas cap or add fuel while the engine is hot or running.
 - e. Allow engine to cool at least two minutes before refueling and at least 5 minutes before storing.
 - f. Never over fill fuel tank. Fill tank to no more than ½ inch below bottom of filler neck to provide space for fuel expansion.
 - g. Replace gasoline cap and tighten securely.
 - h. If gasoline is spilled, wipe it off the engine and equipment. Move machine to another area. Wait 5 minutes before starting the engine.
 - i. Never store the machine or fuel container inside where there is an open flame, spark or pilot light (e.g. furnace, water heater, space heater, clothes dryer etc).

Preparation

1. Thoroughly inspect the area where the equipment is to be used. Remove all door mats, newspapers, sleds, boards, wires and other foreign objects which could be tripped over or thrown by the auger/impeller.
2. Always wear safety glasses or eye shields during operation and while performing an adjustment or repair to protect your eyes. Thrown objects which ricochet can cause serious injury to the eyes.
3. Do not operate without wearing adequate winter outer garments. Do not wear jewelry, long scarves or other loose clothing which could become entangled in moving parts. Wear footwear which will improve footing on slippery surfaces.
4. Use a grounded three wire extension cord and receptacle for all units with electric start engines.
5. Adjust collector housing height to clear gravel or crushed rock surfaces.
6. Disengage all clutch levers before starting the engine.
7. Never attempt to make any adjustments while engine is

Operation

1. Do not put hands or feet near rotating parts, in the auger/impeller housing or discharge chute. Contact with the rotating parts can amputate hands and feet.
2. The auger/impeller clutch lever is a safety device. Never bypass its operation. Doing so, makes the machine unsafe and may cause personal injury.
3. The clutch levers must operate easily in both directions and automatically return to the disengaged position when released.
4. Never operate with a missing or damaged discharge chute. Keep all safety devices in place and working.
5. Never run an engine indoors or in a poorly ventilated area. Engine exhaust contains carbon monoxide, an odorless and deadly gas.

6. Do not operate machine while under the influence of alcohol or drugs.
7. Muffler and engine become hot and can cause a burn. Do not touch.
8. Exercise extreme caution when operating on or crossing gravel surfaces. Stay alert for hidden hazards or traffic.
9. Exercise caution when changing direction and while operating on slopes.
10. Plan your snow throwing pattern to avoid discharge towards windows, walls, cars etc. To avoid property damage or personal injury caused by a ricochet.
11. Never direct discharge at children, bystanders and pets or allow anyone in front of the machine.
12. Do not overload machine capacity by attempting to clear snow at too fast of a rate.
13. Never operate this machine without good visibility or light. Always be sure of your footing and keep a firm hold on the handles. Walk, never run.
14. Disengage power to the auger/impeller when transporting or not in use.
15. Never operate machine at high transport speeds on slippery surfaces. Look down and behind and use care when in reverse.
16. If the machine should start to vibrate abnormally, stop the engine, disconnect the spark plug and ground it against the engine. Inspect thoroughly for damage. Repair any damage before starting and operating.
17. Disengage all clutch levers and stop engine before you leave the operating position (behind the handles). Wait until the auger/impeller comes to a complete stop before unclogging the discharge chute, making any adjustments, or inspections.
18. Never put your hand in the discharge or collector openings. Always use a clearing tool to unclog the discharge opening.
19. Use only attachments and accessories approved by the manufacturer (e.g. wheel weights, tire chains, cabs etc.).
20. If situations occur which are not covered in this manual, use care and good judgment. Contact your nearest Sears service center for assistance.

Maintenance and Storage

1. Never tamper with safety devices. Check their proper operation regularly.
2. Disengage all clutch levers and stop engine. Wait until the auger/impeller come to a complete stop. Disconnect the spark plug wire and ground against the engine to prevent unintended starting before cleaning, repairing, or inspecting.
3. Check bolts, and screws for proper tightness at frequent intervals to keep the machine in safe working condition. Also, visually inspect machine for any damage.
4. Do not change the engine governor setting or over-speed the engine. The governor controls the maximum safe operating speed of the engine.
5. Snow thrower shave plates and skid shoes are subject to wear and damage. For your safety protection, frequently check all components and replace with original equipment manufacturer's (O.E.M.) parts only. "Use of parts which do not meet the original equipment specifications may lead to improper performance and compromise safety!"
6. Check clutch controls periodically to verify they engage and disengage properly and adjust, if necessary. Refer to the adjustment section in this operator's manual for instructions.
7. Maintain or replace safety and instruction labels, as necessary.
8. Observe proper disposal laws and regulations for gas, oil, etc. to protect the environment.
9. Prior to storing, run machine a few minutes to clear snow from machine and prevent freeze up of auger/impeller.
10. Never store the machine or fuel container inside where there is an open flame, spark or pilot light such as a water heater, furnace, clothes dryer etc.
11. Always refer to the operator's manual for proper instructions on off-season storage.

Your Responsibility:

Restrict the use of this power machine to persons who read, understand and follow the warnings and instructions in this manual and on the machine. The most important safety labels are reproduced below. For a detailed labels map, see Parts List section.

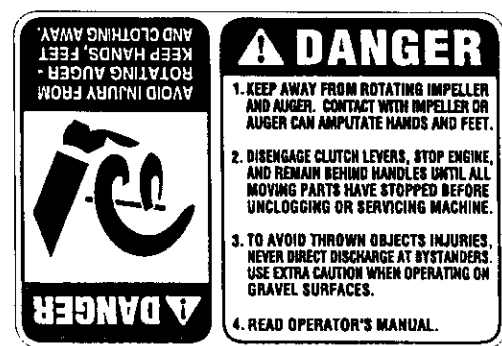
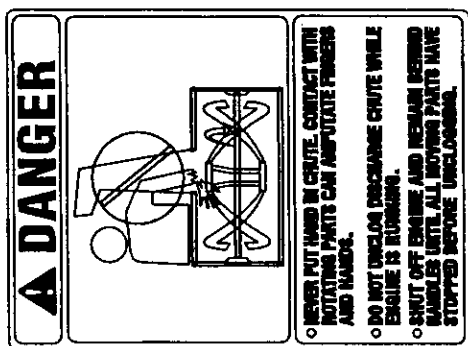

HARDWARE PACK

Lay out the hardware according to the illustration below for identification purposes. Part numbers are shown in parentheses. (Hardware pack may contain extra items which are not used on your unit.)

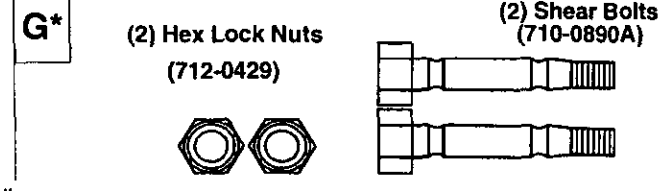
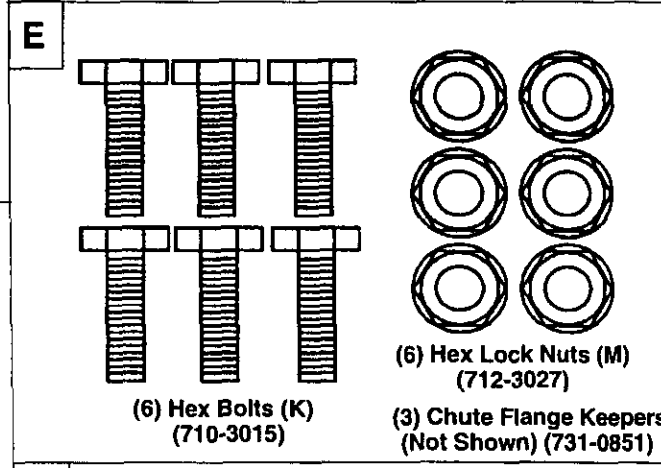
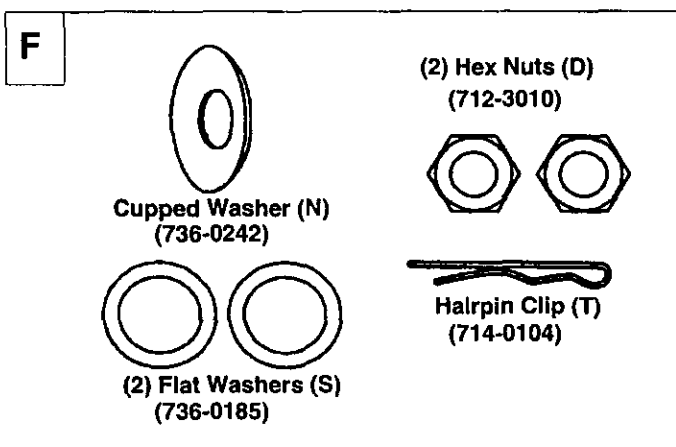
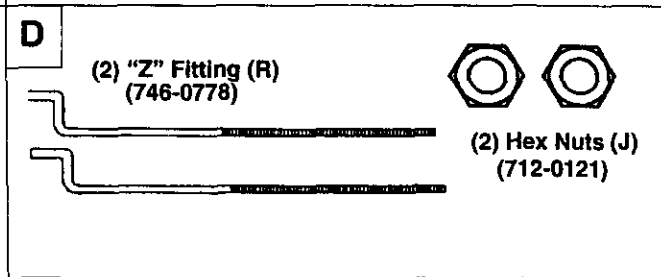
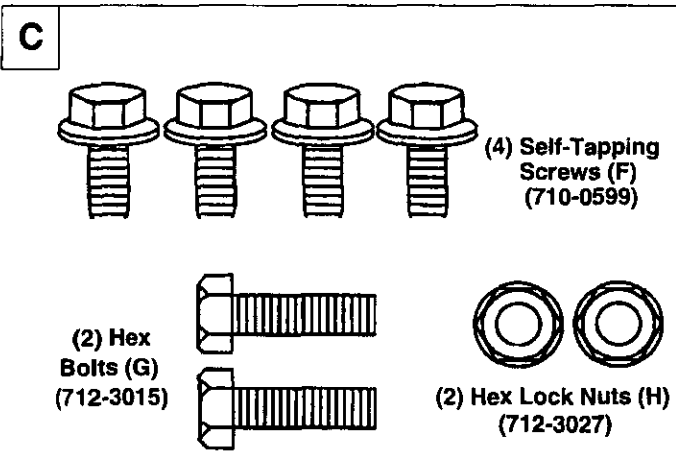
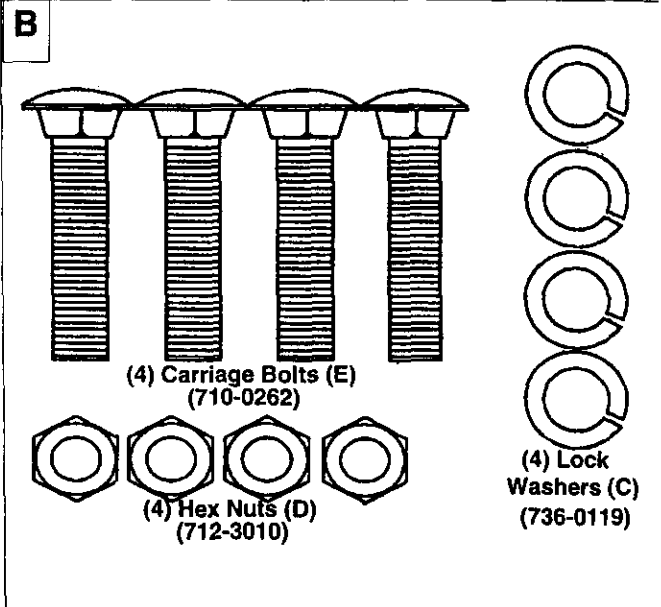
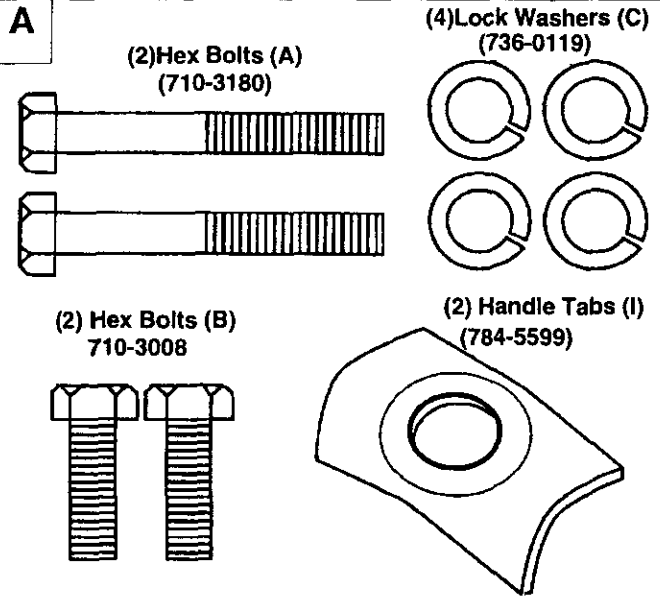

* Replacement hardware only; not required in initial assembly of the snow thrower.

ASSEMBLY

NOTE: References to right or left side of the snow thrower are determined from behind the unit in the operating position.

Unpacking

- Remove staples from top flaps of the carton. Remove any loose parts included with unit (i.e., operator's manual, etc.).
- Cut corners of the carton and lay ends down flat. Remove packing material.
- Roll unit out of carton. Check carton thoroughly for loose parts before discarding.

Loose Parts In Carton

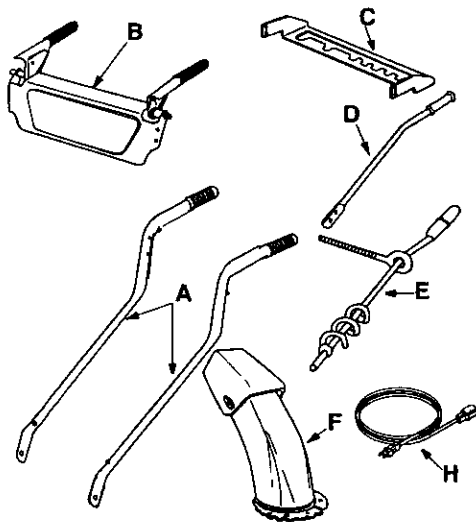

Figure 1

- Compare Figure 1 with the list below to identify loose parts in the carton.

Ref.	Description	Qty.
A	Handles (Right and Left)	2
B	Handle Panel	1
C	Speed Selector Plate	1
D	Shift Lever	1
E	Chute Directional Control Assembly	1
F	Chute Assembly	1
G	Hardware Pack*	1
H	Extension Cord	1

* Shown on Page 5

Before Assembly



WARNING: Disconnect the spark plug wire and ground it against the engine to prevent unintended starting.

NOTE: All hardware pieces identified by a letter code here correspond to the letter code used in the description of the hardware pack on page 5.

- Take the two "Z" fittings from Group D of the Hardware Pack and insert the Z end of these through the two holes on the two clutch grips on the handle panel. The handle panel was shipped as loose part with your snow thrower.

Assembly Tips:

- For easier assembly purposes, remove the chute from the carton and lay it on top of the engine. Do not unwrap the chute till you have installed the handle panel and the clutch cables.
- Look for stampings of L and R respectively on the bottom of the left and the right handles to identify.

Tools Required

- Two 7/16" wrenches or a set of adjustable wrenches.

Attaching Handles

(Use hardware group B.)

- Raise both clutch grips.
- Lower left and right handles down through handle panel between the pivot rod and the clutch grips and attach using two each of carriage bolts (E), lock washers (C) and hex nuts (D). See Figure 2.

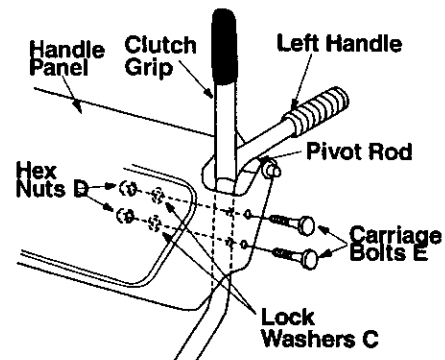

Figure 2

- Do not tighten at this time.
- Lay handle panel assembly behind snow thrower as shown in Figure 3.

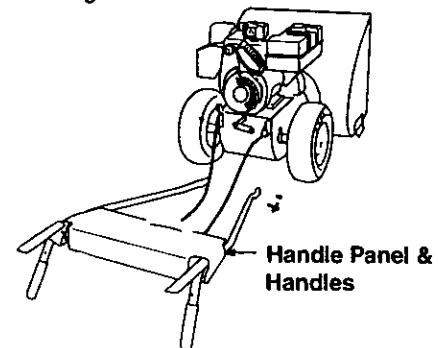

Figure 3

(Use hardware group A.)

- Insert one each of hex bolt (B) and lock washer (C), from Group A of the hardware pack, through the bottom hole in left handle and corresponding hole in snow thrower housing. See Figure 4. Do not tighten. Repeat on the other side.
- Raise both handles up until the upper hole in each handle align with the upper hole on each side of the snow thrower housing. Secure with hex bolt (A), lock washer (C) and handle tab (I) on each side. See Figure 4.

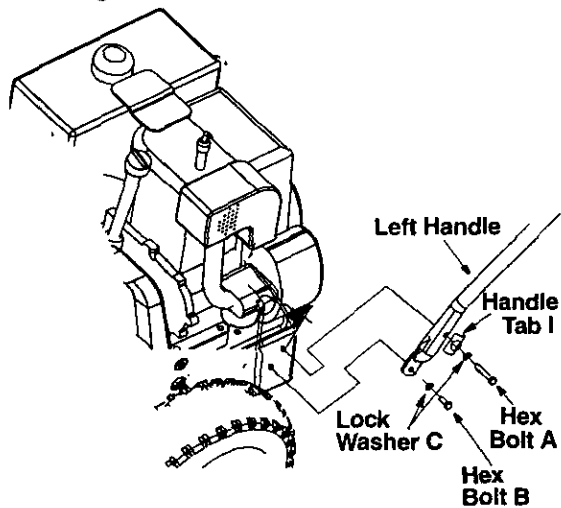

Figure 4

Attaching Speed Selector Plate

(Use hardware group C.)

- Assemble the speed selector plate to the **outside** of the handles as shown in Figure 5. Secure using two self-tapping screws (F) from hardware group C. Repeat on the other side.

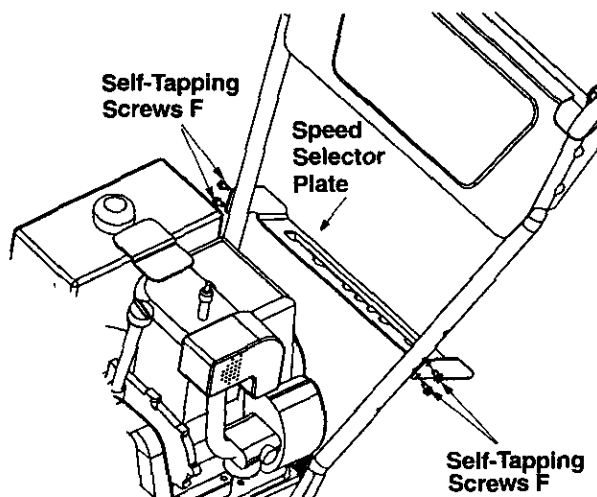

Figure 5

Attaching Shift Lever

(Use hardware group C.)

- Insert the shift lever through slot in the speed selector plate. See Figure 6. The bend in the lever should be towards the operator.

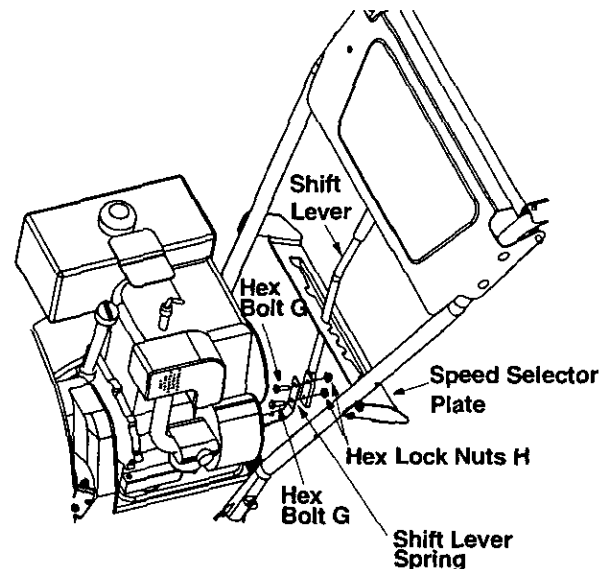

Figure 6

- Secure shift lever to the shift lever spring using two hex bolts (G) and hex lock nuts (H). See Figure 6. Tighten both bolts finger tight. At this point the shift lever and shift lever spring are not against each other. As you tighten the bolts and nuts with two wrenches, these will pull together.
- Tighten all hardware assembled to this point. Make sure that clutch grips are moving freely.

Attaching Control Cables

(Use hardware group D.)

- Since the Z fitting is already inserted into the hole on the clutch grip at this point, thread a hex nut (J) from hardware pack D on to each Z fitting. See Figure 7.
- Route the left cable between engine and speed selector plate and then between handle panel and clutch lever pivot rod. Thread cable onto the left "Z" fitting.
- Assemble the right cable in the same manner.
- Both cables should have minimal slack, but not tight. Tighten or loosen hex nuts on the "Z" fitting to adjust.

IMPORTANT: If the right hand lock-out cable is not adjusted correctly, the wheels will tend to turn. If the left hand lock-out cable is not adjusted correctly, the augers will keep on rotating.

NOTE: The drive clutch cable is routed over the axle.



WARNING: Do not over-tighten the clutch cables. Tension on either cable in the disengaged (up) position may override the safety features of the machine.

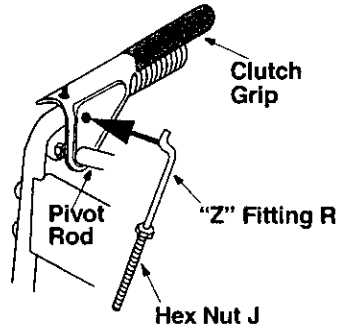

Figure 7

Attaching Chute Assembly

(Use hardware group E.)

- Place chute assembly over chute opening, with the opening in the chute assembly facing the front of the unit.
- Place chute flange keepers beneath lip of chute assembly, with the flat side of chute flange keeper facing downward. See Figure 8.

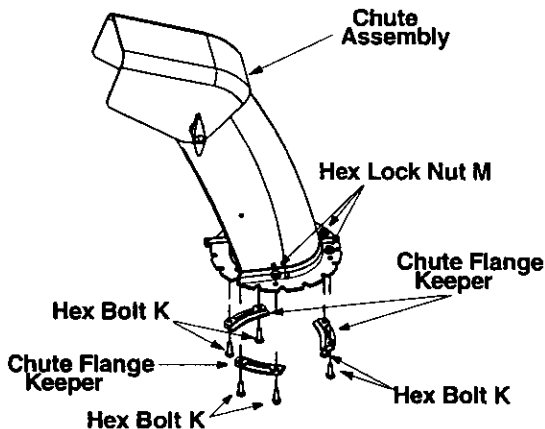

Figure 8

- Insert two hex bolts (K) up through each chute flange keeper and chute assembly as shown in Figure 8. Secure with hex lock nuts (M). After assembling all three chute flange keepers, tighten all nuts and bolts securely. Do not over-tighten.

NOTE: Lock nuts cannot be threaded by hand; use two 7/16" sized or adjustable wrenches instead.

Attaching Chute Directional Control

(Use hardware group F.)

- Loosen the two hex nuts which secure the lower chute directional control support bracket (see Figure 9 inset) to the snow thrower housing.

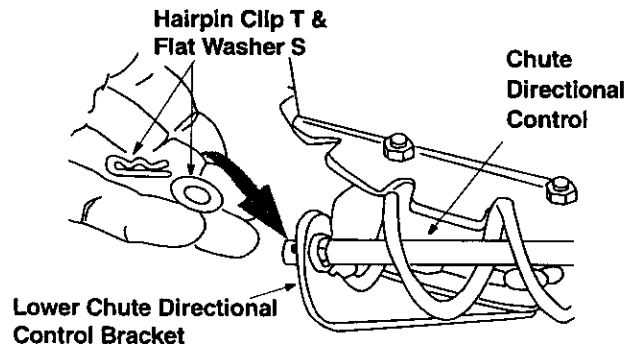
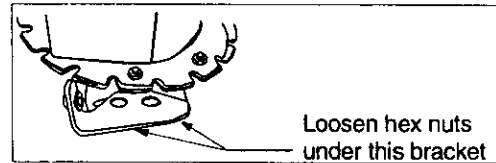

Figure 9

- Place one flat washer (S), from group F, over the end of the chute directional control, then insert the end of the chute directional control into the hole in the plastic bushing on the chute bracket. See Figure 9. Place the remaining flat washer (S) on chute directional control, and secure with hairpin clip (T).
- Thread one hex nut (D), from group F, onto the eyebolt on the chute directional control assembly until there is at least two inches of threads showing between the nut and the eyebolt head. See Figure 10 inset.
- Place the eyebolt into the hole located half way up the left handle. See Figure 10. Secure with cupped washer (N) and hex nut (D), from group F, making sure that the cupped side of the washer is against the handle.

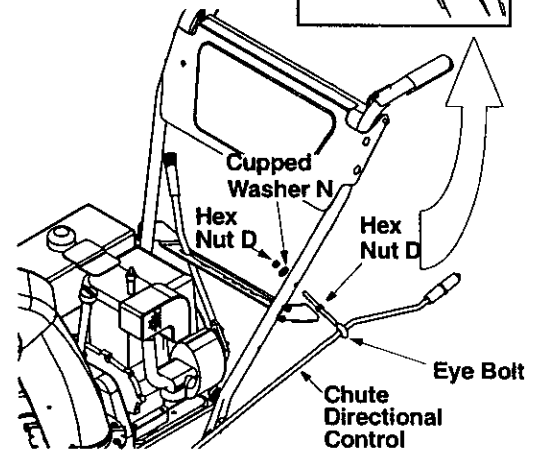
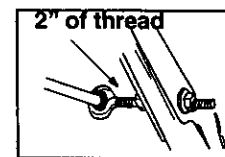

Figure 10

- Adjust the chute directional control bracket so that the spiral on the chute directional control fully engages the teeth on the chute assembly. See Figure 11. Tighten all hardware.

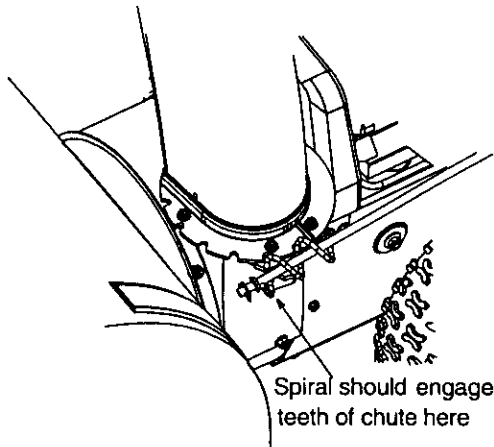

Figure 11

- Check to make sure all nuts and bolts on the control panel and all four bolts which secure the handles to the frame are very tight.

Final Assembly & Adjustments

Auger Control

- To check the adjustment of the auger control, push forward on the left hand clutch grip (depress the rubber bumper). There should be slack in the cable. Release the clutch grip. The cable should be straight. Make certain you can depress the auger control grip against the left handle completely.
- If necessary, loosen the hex lock nut and thread the cable in (for less slack) or out (for more slack) as necessary. Refer to Figure 7.
- Tighten the lock nut against the cable when correct adjustment is reached.

Traction Control & Shift Lever

- To check the adjustment of the traction control and shift lever, move the shift lever all the way to the right to fifth (5) position. With the traction control released, push the snow thrower forward. The unit should move forward freely. Then engage the traction control grip. The wheels should stop turning.
- Now release the traction control grip, and push the unit again. Move the shift lever back to the fast reverse position, then all the way forward again. There should be no resistance in the shift lever, and the wheels should keep turning.
- If you feel resistance when moving the shift lever or the wheels stop when they should not, loosen the jam nut on the traction control cable and unthread the cable one turn.

- If the wheels do not stop when you engage the traction control grip, loosen the jam nut on the traction control cable and thread the cable in one turn.
- Recheck the adjustment and repeat as necessary. Tighten the jam nut to secure the cable when correct adjustment is reached.

NOTE: If you are not sure that you have adjusted correctly, refer to the Adjustment section on page 15.

Skid Shoes

The space between the shave plate and the ground can be adjusted.

- For close snow removal on a smooth surface, raise skid shoes higher on the auger housing. See Figure 12.
- Use a middle or lower position when the area to be cleared is uneven. See Figure 12.

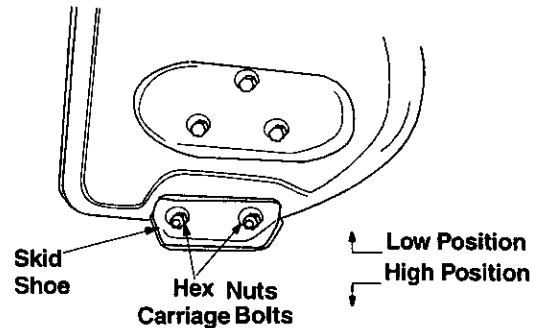

Figure 12

- Adjust skid shoes by loosening the four hex nuts and carriage bolts as shown in Figure 12. Move skid shoes to desired position.
- Make certain the entire bottom surface of skid shoe is against the ground to avoid uneven wear on the skid shoes. Retighten nuts and bolts securely.

Tire Pressure (Pneumatic Tires)

The tires are overinflated for shipping purposes.

- Check tire pressure. Maintain pressure between 15 to 20 psi. Refer to tire sidewalls for recommended tire pressure.

NOTE: If the tire pressure is not equal in both tires, the unit may pull to one side or the other.



WARNING: Maximum tire pressure under any circumstance is 30 psi. Equal tire pressure should be maintained at all times. Excessive pressure (over 30 psi) when seating beads may cause tire/rim assembly to burst with force sufficient to cause serious injury.

IMPORTANT: After assembly, service engine with gasoline, and check oil level as instructed in the separate engine manual packed with your unit.

OPERATION

Knowing your Snow Thrower



WARNING: Be familiar with all the controls and their proper operation. Know how to stop the machine and disengage them quickly.

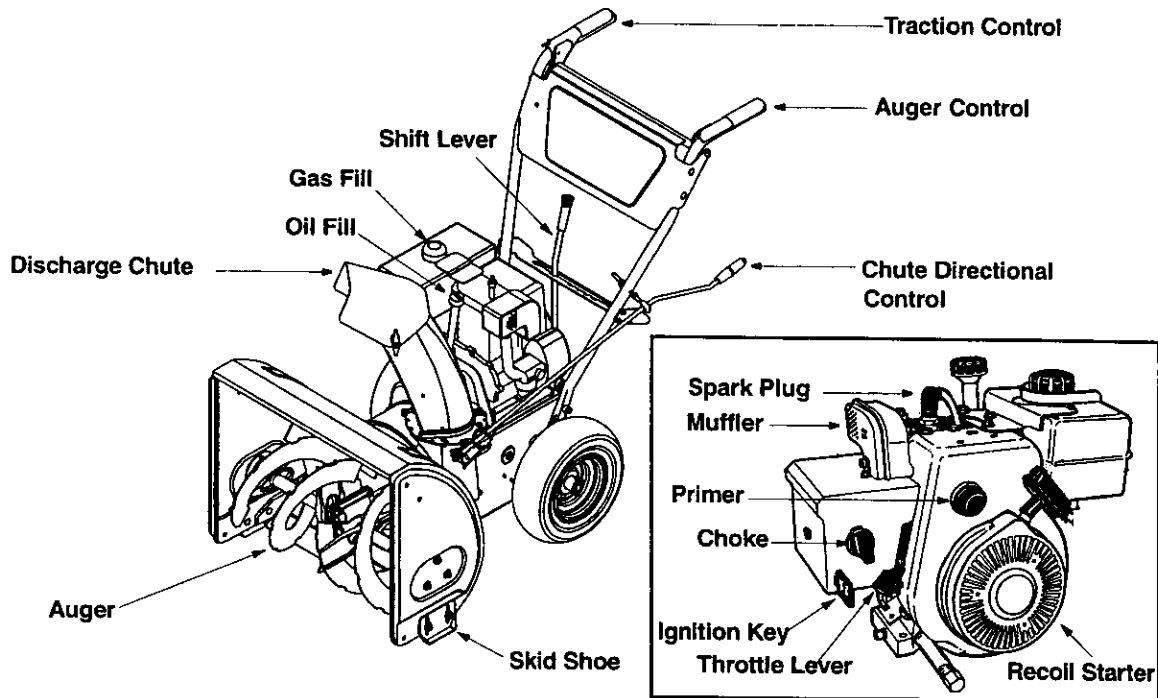

Figure 13

Operating Controls

Shift Lever

The shift lever is located below the handle panel. See Figure 13. The shift lever may be moved into one of seven positions. Run engine with throttle in the fast position. Use the shift lever to determine ground speed. There are five forward and two reverse speeds on this snow thrower. Among the forward speeds, position one (1) is the slowest and position five (5) is the fastest. Among reverse speeds, R2 is the faster.

Auger Control

The auger control is located on the left handle. Squeeze the auger control grip to engage the augers. Release to stop the augers. See Figure 13.

Traction Control

The traction control is located on the right handle. Squeeze the traction control grip to engage the wheel drive. Release to stop. See Figure 13.

Throttle Control

The throttle control is located on the engine. It regulates the speed of the engine. See Figure 13.

Chute Directional Control

The chute directional control is located on left side of the snow thrower. See Figure 13. To change the direction in which snow is thrown, turn chute directional control as follows:

- Crank clockwise to discharge to the left.
- Crank counterclockwise to discharge to the right.

Ignition Key

The ignition key must be inserted in the switch before the unit will start. See Figure 13 inset. Remove the ignition key when snow thrower is not in use. Do not turn ignition key.

Stopping the engine

- To stop engine, move throttle control to "stop" or "off" position. Remove the ignition key. Do not turn key.
- Disconnect the spark plug wire from the spark plug to prevent accidental starting while equipment is unattended.

Before Starting



WARNING: Read, understand, and follow all instructions and warnings on the machine and in this manual before operating.

- The engine was shipped with oil. Check the oil level before operating. After the initial use, you will have to fill up as necessary. Be careful not to overfill.
- **Before filling up gas** in the engine for the first time, open the gas tank cap, and locate a white plastic cap underneath. Remove this cap and discard it.
- The spark plug wire was disconnected for safety. Attach spark plug wire to spark plug before starting.

Before Starting Engine

Fill Gas



WARNING: Gasoline is flammable and caution must be used when handling or storing it.

Do not fill fuel tank while the snow thrower is running, when it is hot or when it is in an enclosed area.

Keep your snow thrower away from any open flame or an electrical spark and do not smoke while filling the fuel tank.

Never fill the fuel tank completely. Fill the tank to within 1/4"-1/2" from the top to provide space for expansion of fuel.

Always fill the fuel tank outdoors and use a funnel or spout to prevent spilling.

Make sure to wipe off any spilled fuel before starting the engine.

- Store gasoline in a clean, approved container and keep the cap in place on the container.
- Make sure that the container from which you pour the gasoline is clean and free from rust or other foreign particles.
- Fill fuel tank with clean, fresh, unleaded grade automotive gasoline.
- At the end of the job, empty the fuel tank if the snow thrower is not going to be used for 30 days or longer. See storage instructions on page 19 of this manual.

CAUTION: Experience indicates that alcohol blended fuels (called gasohol) or those using ethanol or methanol can attract moisture which leads to separation and formation of acids during storage.

Acidic gas can damage the fuel system of an engine while in storage.

To avoid engine problems, the fuel system should be emptied before storage for 30 days or longer. Drain the gas tank, start the engine and let it run until the fuel lines

and carburetor are empty. Use fresh fuel next season. See storage instructions for additional information.

Never use engine or carburetor cleaner products in the fuel tank or permanent damage may occur.

To Start Engine

- Attach spark plug wire to spark plug. Make certain the metal loop on the end of the spark plug wire (inside the boot) is fastened securely over the metal tip on the spark plug. See Figure 14.

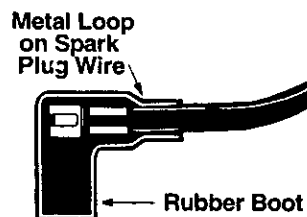

Figure 14

- Make certain the auger and drive clutch levers are in the disengaged (released) position.
- Move throttle control up to FAST position. Insert ignition key into slot. Make sure it snaps into place.
Do not turn key.

NOTE: Engine will not start unless ignition key is inserted into ignition slot in carburetor cover.

Electric Starter



WARNING: The electric starter is equipped with a grounded three-wire power cord and plug, and is designed to operate on 120 volt AC household current. It must be used with a properly grounded three-prong receptacle at all times to avoid the possibility of electric shock. Follow all instructions carefully prior to operating the electric starter.

- Determine that your house wiring is a three-wire grounded system. Ask a licensed electrician if you are not certain.
- **If your house wiring system is not a three-wire grounded system**, do not use this electric starter under any conditions.
- **If your home electrical system is grounded**, but a three-hole receptacle is not available, one should be installed by a licensed electrician before using the electric starter.
- **If you have a grounded three-prong receptacle**, proceed as follows.
- Rotate choke knob to OFF position.
- Connect power cord to switch box on engine. Plug the other end of power cord into a three-prong 120-volt, grounded, AC receptacle.
- Push starter button to crank engine. As you crank the engine, move choke knob to FULL choke position.

- When engine starts, release starter button, and move choke gradually to OFF. If engine falters, move choke immediately to FULL and then gradually to OFF.
- When disconnecting the power cord, always unplug from the three-prong receptacle first, and then from the snow thrower.

Recoil Starter

- Rotate choke knob to FULL choke position (cold engine start).
- If engine is warm, place choke in OFF position instead of FULL.
- Push primer button two or three times for cold engine start.
- If engine is warm, push primer button only once.

NOTE: Always cover vent hole in primer button when pushing. Additional priming may be necessary for first start if temperature is below 15 degrees Fahrenheit.

- Grasp starter handle and pull rope out slowly, until it pulls slightly harder. Let rope rewind slowly.
- Pull starter handle rapidly. Do not allow handle to snap back. Allow it to rewind slowly while keeping a firm hold on the starter handle.
- As engine warms up and begins to operate evenly, rotate choke knob slowly to OFF position. If engine falters, return to FULL choke, then slowly move to OFF position.

To Stop Engine

- Run engine for a few minutes before stopping to help dry off any moisture on the engine.
- To help prevent possible freeze-up of starter, proceed as follows.

Electric Starter

- Connect power cord to switch box on engine, then to 120 volt AC receptacle. With the engine running,

push starter button and spin the starter for several seconds. The unusual sound made by spinning the starter will not harm engine or starter. Disconnect the power cord from receptacle first, and then from switch box.

Recoil Starter

- With engine running, pull starter rope with a rapid, continuous full arm stroke three or four times. Pulling the starter rope will produce a loud clattering sound, which is not harmful to engine or starter.
- To stop engine, move throttle control to "stop" or "off" position.
- Remove the ignition key. Do not turn key.
- Disconnect the spark plug wire from the spark plug to prevent accidental starting while equipment is unattended.

NOTE: Do not lose ignition key. Keep it in a safe place. Engine will not start without the ignition key.

- Wipe all snow and moisture from the carburetor cover in the area of the control levers. Also, move control levers back and forth several times.

To Engage Drive

- With the engine running near top speed, move shift lever into one of the five FORWARD positions or two REVERSE positions. Select a speed appropriate for the snow conditions that exist. Use the slower speeds until you are familiar with the operation of the snow thrower.
- Squeeze the auger control grip and the augers will turn. Release it and the augers will stop.
- Squeeze traction control grip and the snow thrower will move. Release it and drive motion will stop.
- NEVER move shift lever without releasing drive clutch.



Starting Instructions At A Glance

Snow Thrower	Spark Plug wire	Drive Levers	Throttle control	Ignition Key	Choke	Power Cord	Primer	Starter	After starting
Electric Starter	Connect	Release	Move to FAST	Push to snap in	Move to FULL	Connect to source	—	Push button	1. Release button 2. Move Choke to Off 3. Disconnect cord
Recoil Starter	Connect	Release	Move to FAST	Push to snap in	Move to FULL	—	Prime	Pull handle	1. Release handle 2. Move Choke to Off.

To Engage Augers

- To engage the augers and start throwing snow, squeeze the auger control grip against the left handle. Release to stop the augers.

Operating Tips

- Allow the engine to warm up for a few minutes as the engine will not develop full power until it reaches operating temperature.



WARNING: Muffler, engine and surrounding areas become hot and can cause a burn. Do not touch.

- For most efficient snow removal, remove snow immediately after it falls.
- Discharge snow downwind whenever possible. Slightly overlap each previous swath.
- Set the skid shoes 1/4" below the scraper bar for normal usage. The skid shoes may be adjusted upward for hard-packed snow. Adjust downward when using on gravel or crushed rock.
- Be certain to follow the precautions listed under "To Stop Engine" to prevent possible freeze-up.
- Clean the snow thrower thoroughly after each use.

Tire Chains (If equipped)

- Tire chains, if your snow thrower is so equipped, should be used whenever extra traction is needed.

MAINTENANCE

General Recommendations

- Always observe safety rules when performing any maintenance.
- The warranty on this snow thrower does not cover items that have been subjected to operator abuse or negligence. To receive full value from the warranty, operator must maintain the snow thrower as instructed in this manual.
- Some adjustments will have to be made periodically to maintain your unit properly.
- All adjustments in the Service and Adjustments section of this manual should be checked at least once each season.
- Follow the maintenance schedule given below.
- Periodically check all fasteners and make sure these are tight.

Customer Responsibilities

MAINTENANCE SCHEDULE		Before each use	After each use	First two hours	Every 25 hours	Every 100 hours	Before storage	SERVICE DATES*							
PRODUCT	Lubricate pivot points			✓		✓									
	Clean snow thrower		✓				✓								
	Clean shave plate				✓										
	Clean skid shoes				✓										
	Check V-belts					✓									
	Check friction wheel rubber					✓									
ENGINE	Check engine oil	✓													
	Change engine oil			✓	✓										
	Check spark plug					✓	✓								
	Check muffler					✓									
	Empty fuel system						✓								

* Fill in dates as you complete regular service
 ✓ Check; service if needed

Lubrication



WARNING: Before lubricating, repairing, or inspecting, disengage all clutch levers and stop engine. Wait until all moving parts have come to a complete stop. Disconnect spark plug wire and ground it against the engine to prevent unintended starting.

IMPORTANT: When lubricating engine or draining oil, avoid dripping oil onto transmission parts.

Wheels

- Oil or spray lubricant into bearings at wheels at least once a season. Pull klick pin, remove wheels, clean and coat axles with a multipurpose automotive grease. See Figure 15

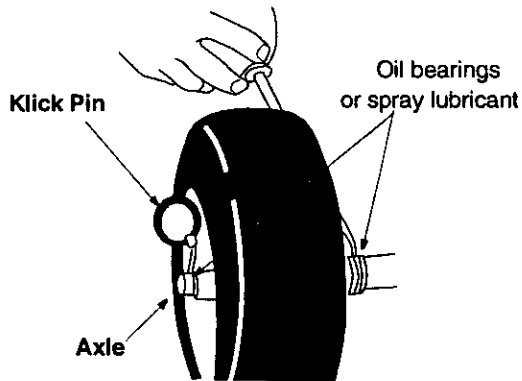

Figure 15

Chute Directional Control

- The worm gear on the chute control should be lubricated with multipurpose automotive grease.

Auger Shaft

- At least once a season, remove shear bolts on auger shaft. Oil or spray lubricant inside shaft and lubricate the auger bearings. See Figure 16.

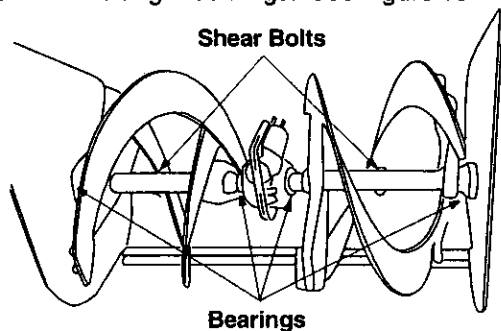

Figure 16

Gear Shaft

- Lubricate the gear shaft with a good all-weather multi-purpose light grease at least once a season or after every 25 hours of operation. Keep all grease and oil off the friction wheel and drive plate.

Drive and Shifting Mechanism

- Remove rear cover. Oil any chains, sprockets, gears, bearings, shafts, and shifting mechanism at least once a season. See Figure 17. Use engine oil or a spray lubricant. Avoid getting oil on rubber friction wheel and aluminum drive plate.

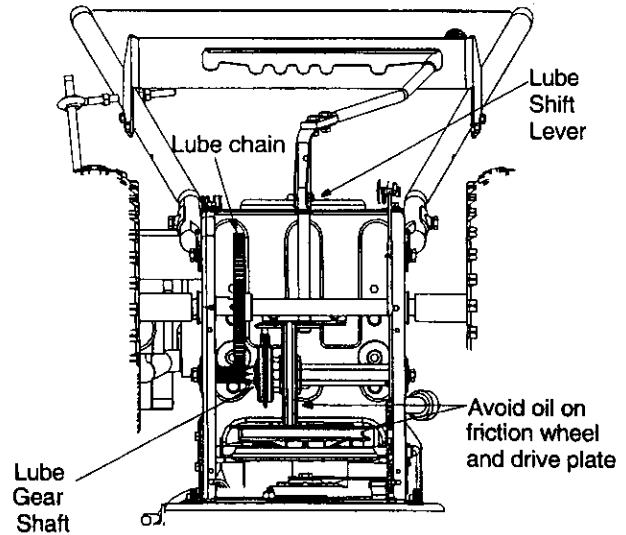

Figure 17

Gear Case

- The worm gear case has been filled with grease at the factory. If disassembled for any reason, lubricate with 2 ounces of shell grease.

IMPORTANT: Do not overfill the gear case. Damage to the seals could result. Be sure the vent plug is free of grease in order to relieve pressure.

Friction Wheel

- The rubber on the friction wheel is subject to wear and should be checked after 25 hours of operation, and periodically thereafter. Replace the friction wheel rubber if any signs of wear or cracking are found following instructions on page 18.

Engine Maintenance

Engine Oil

Only use high quality detergent oil rated with API service classification SF, SG or SH. Select the oil's SAE viscosity grade according to the expected operating temperature.

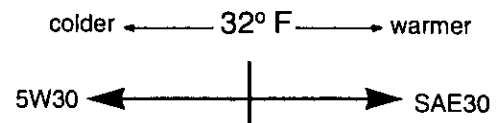

Viscosity Chart

NOTE: Although multi-viscosity oils (5W30, 10W30 etc.) improve starting in cold weather, these multi-viscosity oils will result in increased oil consumption when used above 32°F. Check your snow thrower's engine oil level more frequently to avoid possible engine damage from running low on oil.

- Refer to the viscosity chart for proper selection of engine oil. Do not use SAE 10W40 oil.

Checking Oil Level

- Before operating the snow thrower, check the oil level. With engine on level ground, the oil must be to FULL mark on dipstick.
- Stop engine and wait several minutes before checking oil level. Remove oil fill cap and dipstick.
- Wipe dipstick clean, insert it into oil fill hole and tighten securely.
- Remove dipstick and check. If oil is not up to the FULL mark on dipstick, add oil.

Changing Oil

Change engine oil after first two hours of operation and every 25 hours thereafter.

In order to change the oil, you will have to first drain the spent engine oil from the engine and then refill with fresh oil.

- Drain oil while engine is warm. Remove oil drain cap located at the bottom of the recoil starter of the engine. Catch oil in a suitable container.
- When engine is drained of all oil, replace drain plug securely.
- Remove the dipstick from the oil fill. Pour fresh oil slowly through the plug. Replace dipstick.

- Check and make sure that the level of oil is up to the FULL mark on the dipstick. The oil sump capacity is 21 ounces or 0.62 liters.



WARNING: Temperature of muffler and nearby areas may exceed 150° F (65°C). Avoid these areas.

Spark Plug

- Clean area around the spark plug base.
- Remove and inspect the spark plug.
- Replace the spark plug if electrodes are pitted, burned, or the porcelain is cracked. See Figure 18.
- Clean the spark plug and reset the gap to 0.030" at least once a season or every 100 hours of operation. See Figure 18. Replace if necessary.
- For replacement, use Champion J-8C, Autolite 356 or equivalent spark plug.

NOTE: Do not sandblast spark plug. Spark plug should be cleaned by scraping or wire brushing and washing with a commercial solvent.

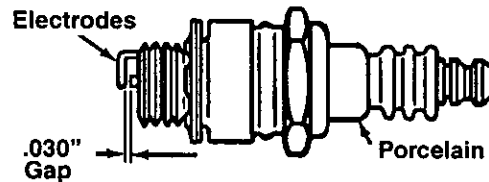

Figure 18

Tire Pressure

- Follow instructions on page 9.

SERVICE & ADJUSTMENTS

Making Adjustments



WARNING: Never attempt to make any adjustments while the engine is running, except where specified in operator's manual.

Chute Assembly

- The distance snow is thrown can be controlled by adjusting the angle of the top section of the chute assembly.

Skid Shoe

- The space between the shave plate and the ground can be adjusted. Refer to the Final Assembly and Adjustments section on page 9.

Traction Control

- Drain gasoline and engine oil from the snow thrower. Place plastic film under the gas cap if the snow thrower has already been operated. Tip the

snow thrower so that it rests on the auger housing. See Figure 19.

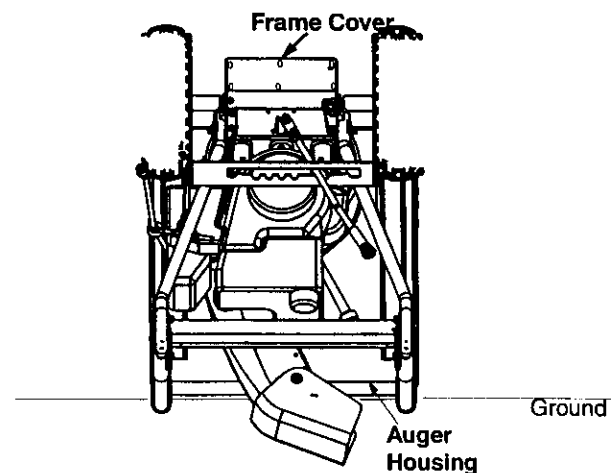

Figure 19

- Remove the frame cover underneath the snow thrower by removing six self-tapping screws. For location of the frame cover, see Figure 19.
- When the traction control is released, there must be clearance between the friction wheel and the drive plate in all positions of the shift lever. When the traction control is engaged, the friction wheel must contact the drive plate. See Figure 20.

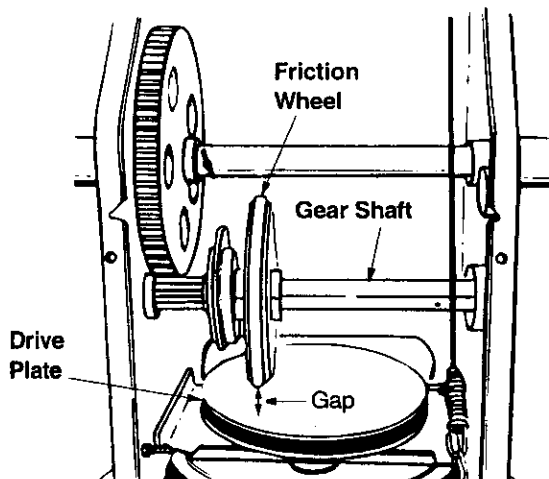

Figure 20

- If any one of these are not occurring, adjustment is necessary. Follow the steps below to adjust the traction control.
- Loosen the lock nut on the traction control cable and thread the cable in or out as necessary. Tighten the lock nut to secure the cable when correct adjustment is reached. Reassemble the frame cover.

NOTE: If you placed plastic under the gas cap earlier, remove it now.

Auger Control

- To adjust the auger clutch, refer to Final Assembly and Adjustments on page 9.

Carburetor



WARNING: If any adjustments need to be made to the engine while the engine is running (e.g. carburetor), keep clear of all moving parts. Be careful of muffler, engine and other surrounding heated surfaces.

- Minor carburetor adjustment may be required to compensate for differences in fuel, temperature, altitude and load.

Drive Wheels

- The wheels may be adjusted for two different methods of operation. Follow the steps below for adjustment. See Figure 21.

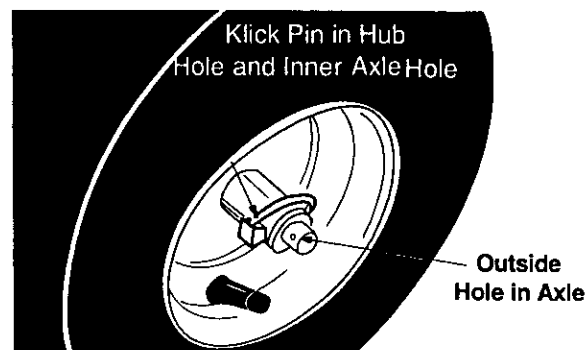

Figure 21

One Wheel Driving

- On the right side of the unit, place klick pin in the outside axle hole only. Do not place pin through wheel hub. This position gives power drive to the left wheel only, making the unit easier to maneuver.

Both Wheels Driving

- Rotate wheel assembly to align hole in the hub with the inner hole on the axle shaft. Insert klick pin in the hole. Outer axle shaft hole should be visible. See Figure 21.



WARNING: Before servicing, repairing, or inspecting, disengage all clutch levers and stop engine. Wait until all moving parts have come to a complete stop. Disconnect spark plug wire and ground it against the engine to prevent unintended starting.

Servicing Augers

- The augers are secured to the spiral shaft with two shear bolts and hex lock nuts. See Figure 16. If you hit a hard foreign object or ice jam, the snow thrower is designed so that the bolts may shear.
- If the augers will not turn, check to see if the bolts have sheared. Replacement shear bolts and hex lock nuts have been provided with the snow thrower. When replacing bolts, spray an oil lubricant into shaft before inserting new bolts.

Shave Plate and Skid Shoes

- The shave plate and skid shoes on the bottom of the snow thrower are subject to wear. They should be checked periodically and replaced when necessary.
- To remove skid shoes, remove the four carriage bolts, cupped washers and hex nuts which attach them to the snow thrower. Reassemble new skid shoes with the four carriage bolts, cupped washers (cupped side goes against skid shoes) and hex nuts. See Figure 22.

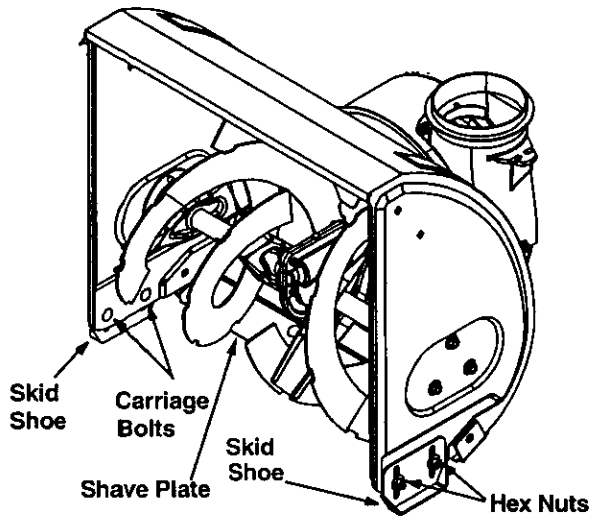

Figure 22

- To remove shave plate, remove the carriage bolts, cupped washers and hex nuts which attach it to the snow thrower housing. See Figure 22. Reassemble new shave plate, making sure heads of carriage bolts are to the inside of housing. Tighten securely.

Replacing Belts



WARNING: Disconnect spark plug wire and ground it against the engine to prevent unintended starting. Drain fuel into an approved container or place a piece of plastic film underneath the gas cap to prevent gasoline from leaking.

Auger Belt

- Remove plastic belt cover from front of the engine by removing the two self-tapping screws. See Figure 23.

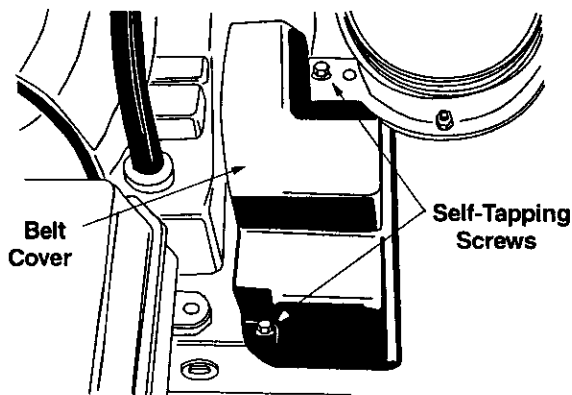

Figure 23

- Drain gasoline from the snow thrower, or place a piece of plastic under the gas cap. Tip the unit up and forward so that it rests on auger housing.
- Remove six self-tapping screws from the frame cover underneath the snow thrower.
- Roll auger belt off engine pulley. See Figure 24.

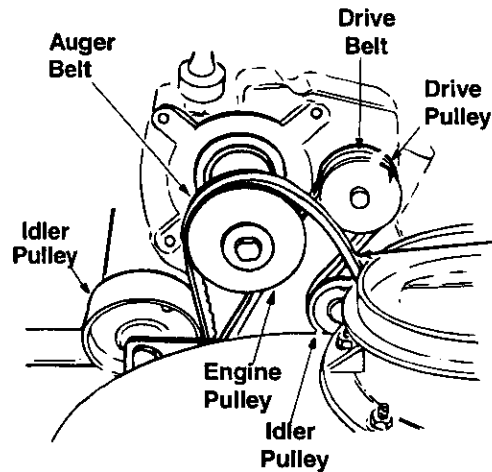

Figure 24

- Unhook the idler spring from the hex bolt on the auger housing. See Figure 25.
- Unhook the support bracket spring from the frame.

NOTE: It may be necessary to loosen the six nuts that connect the frame to the auger housing to aid in belt removal.

- Lift the auger belt from the auger pulley, and slip belt between the support bracket and the auger pulley. See Figure 24.
- Reassemble with new auger drive belt.

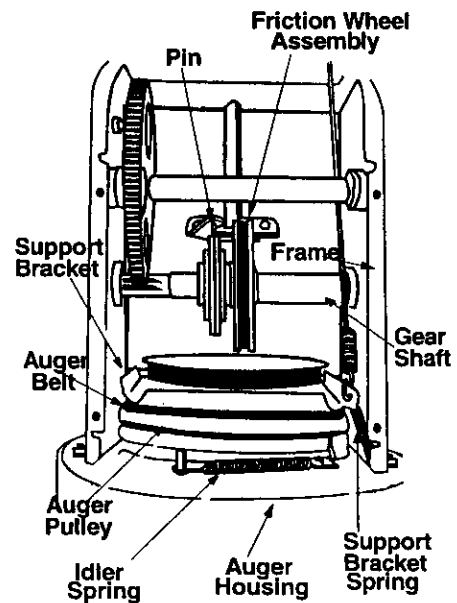

Figure 25

Drive Belt

- Follow first four steps of previous instructions.
- Pull idler pulley up, and lift belt off engine pulley and friction wheel disc. See Figure 24.
- Using a wrench, loosen the nut on the stop bolt until the support bracket rests on the auger pulley. See Figure 26.

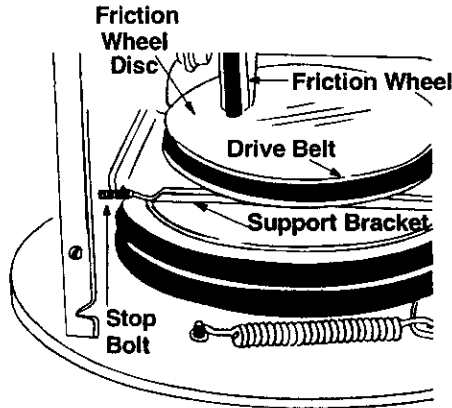

Figure 26

- Slip belt between friction wheel and friction wheel disc. See Figure 26. Remove and replace belt. Reassemble in reverse order.

NOTE: The support bracket must rest on the stop bolt after the new belt has been assembled. See Figure 26.

Replacing Friction Wheel Rubber

Replace the friction wheel rubber if any signs of wear or cracking are found.



WARNING: Disconnect spark plug wire and ground it against the engine to prevent unintended starting. Drain fuel into an approved container or place a piece of plastic film underneath the gas cap to prevent gasoline from leaking.

- Tip the snow thrower up and forward, so that it rests on the housing. See Figure 19. Remove the six self-

tapping screws from the frame cover underneath the snow thrower.

- Remove the click pins which secure the wheels, and remove the wheels from the axle.

Using a wrench to hold the shaft, loosen, but do not completely remove, the hex nut and bell washer on the left end of gear shaft. See Figure 27.

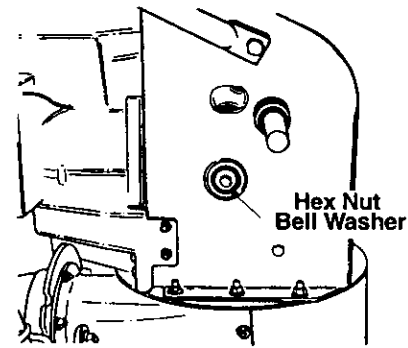

Figure 27

- Lightly tap the hex nut to dislodge the ball bearing from the right side of the frame. Remove the hex nut and bell washer from the left end of the shaft.
- Slide the gear shaft to the right, then slide the friction wheel assembly from the shaft.
- Remove the six screws from the friction wheel assembly (three from each side). See Figure 28.
- Remove the friction wheel rubber from between the friction wheel plate.
- Reassemble new friction wheel rubber to the friction wheel assembly, tightening the six screws in rotation and with equal force. See Figure 28.
- Slide friction wheel assembly back onto the gear shaft. Be sure to align the pin on the shift rod with hole in the friction wheel assembly. See Figure 25.
- Reassemble gear shaft and the wheels. Reattach the frame cover. Flip snow thrower back to its operating position and remove any plastic from under the machine or around the gas cap if you had put it earlier.

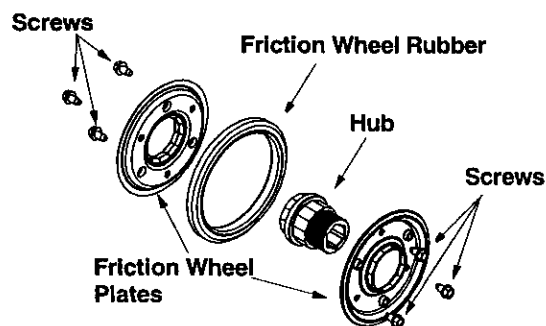

Figure 28

OFF-SEASON STORAGE

If the snow thrower will not be used for 30 days or longer, or at the end of the snow season when the last possibility of snow is gone, the equipment needs to be stored properly. Follow storage instructions below to ensure top performance from the snow thrower for many more years.

Preparing Engine



WARNING: Never store snow thrower with fuel in tank indoors or in poorly ventilated areas, where fuel fumes may reach an open flame, spark or pilot light as on a furnace, water heater, clothes dryer or gas appliance.

It is important to prevent gum deposits from forming in essential fuel system parts of the engine such as the carburetor, fuel filter, fuel hose or tank during storage.

Also experience indicates that alcohol blended fuels (called gasohol or using ethanol or methanol) can attract moisture which leads to separation and formation of acids during storage. Acidic gas can damage the fuel system of an engine while in storage.

To avoid engine problems, the fuel system *should be emptied* before storage for 30 days or longer. Follow these instructions to prepare your snow thrower for storage:

- Remove all gasoline from the carburetor and the fuel tank to prevent gum deposits from forming on these parts and harming the engine.

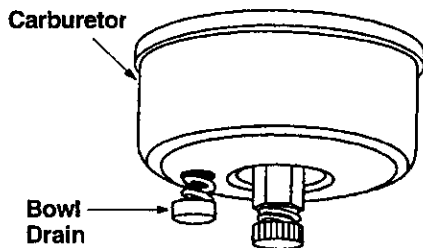

Figure 29



WARNING: Drain fuel into approved container outdoors, away from any open flame. Be certain engine is cool. Do not smoke.

Fuel left in engine during warm weather deteriorates and will cause serious starting problems.

- Run the engine until the fuel tank is empty and it stops due to lack of fuel.
- Drain carburetor by pressing upward on bowl drain, located below the carburetor cover. See Figure 29.



WARNING: Do not drain carburetor if using fuel stabilizer. Never use engine or carburetor cleaning products in the fuel tank or permanent damage may occur.

NOTE: Fuel stabilizer (such as STA-BIL) is an acceptable alternative in minimizing the formation of fuel gum deposits during storage. Add stabilizer to gasoline in fuel tank or storage container. Always follow mix ratio found on stabilizer container. Run engine at least 10 minutes after adding stabilizer to allow it to reach the carburetor. Do not drain carburetor if using fuel stabilizer.

- Remove the spark plug and pour one (1) ounce of engine oil through the spark plug hole into the cylinder. Cover spark plug hole with a rag and crank the engine several times to distribute the oil. Replace spark plug.

Preparing Snow Thrower

- When storing the snow thrower in an unventilated or metal storage shed, care should be taken to rustproof the equipment. Using a light oil or silicone, coat the equipment, especially any chains, springs, bearings and cables.
- Remove all dirt from exterior of engine and equipment.
- Follow lubrication recommendations on page 14.
- Store in a clean, dry area.

TROUBLE SHOOTING GUIDE

Trouble	Possible Cause(s)	Corrective Action
Engine fails to start	Fuel tank empty, or stale fuel. Blocked fuel line. Choke not in ON position Faulty spark plug. Key not in switch on engine. Spark plug wire disconnected. Primer button not depressed.	Fill tank with clean, fresh gasoline. Fuel will not last over thirty days unless a fuel stabilizer is used. Clean fuel line. Move switch to ON position Clean, adjust gap or replace. Insert key. Connect spark plug wire. Prime engine 5 times. See instructions for starting engine .
Engine runs erratic	Unit running on CHOKE. Blocked fuel line or stale fuel. Water or dirt in fuel system.	Move choke lever to OFF position. Clean fuel line; fill tank with clean fresh gasoline. Fuel will not last over thirty days unless a fuel stabilizer is used. Drain fuel tank. Refill with fresh fuel.
Loss of power	Spark plug wire loose. Gas cap vent hole plugged. Exhaust port plugged.	Connect and tighten spark plug wire. Remove ice and snow from cap. Be certain vent hole is clear. Clean engine.
Engine overheats	Carburetor not adjusted properly. Incorrect fuel mixture.	Contact Sears service center. Drain fuel tank. Refill with proper fuel mixture.
Excessive vibration	Loose parts or damaged auger.	Stop engine immediately and disconnect spark plug wire. Tighten all bolts and nuts. Make all necessary repairs. If vibration continues, have unit serviced by an authorized service dealer.
Unit fails to propel itself	Incorrect adjustment of drive cable. Drive belt loose or damaged.	Adjust drive cable. Refer to page 9 of this manual. Replace drive belt. Refer to page 17 of this manual.
Unit fails to discharge snow	Discharge chute clogged. Foreign object lodged in auger. Incorrect adjustment of drive cable. Drive belt loose or damaged. Shear bolts have sheared.	Stop engine immediately and disconnect spark plug wire. Clean discharge chute and inside of auger housing. Stop engine immediately and disconnect spark plug wire. Remove object from auger. Adjust drive cable. Refer to page 9 of this manual. Replace drive belt. Refer to page 17 of this manual. Replace with new shear bolts.

NOTE: For repairs beyond the minor adjustments listed above, please contact your nearest Sears service center.

PARTS LIST

SEARS CRAFTSMAN 5.0 H.P. SNOW THROWER MODEL 247.886640

Safety & Decorative Labels Map

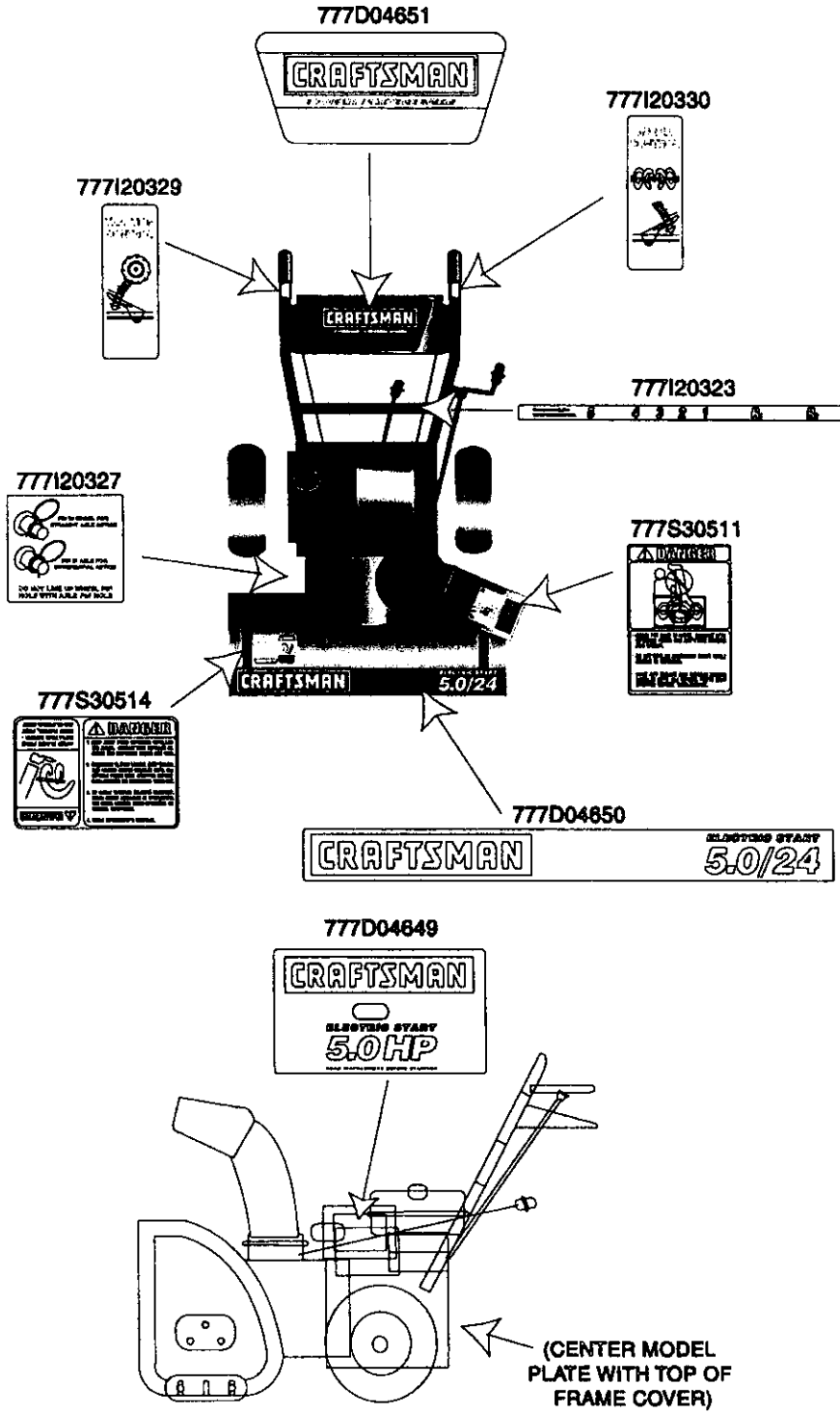

SEARS CRAFTSMAN 5.0 H.P. SNOW THROWER MODEL 247.886640

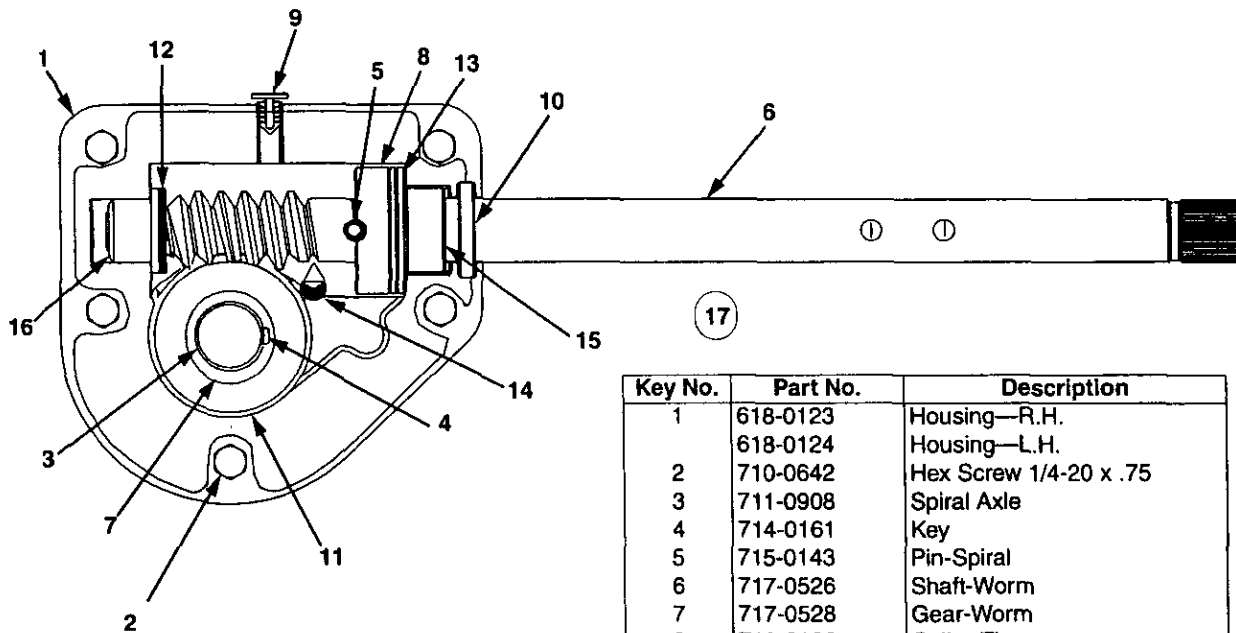

Key No.	Part No.	Description
1	618-0123	Housing—R.H.
	618-0124	Housing—L.H.
2	710-0642	Hex Screw 1/4-20 x .75
3	711-0908	Spiral Axle
4	714-0161	Key
5	715-0143	Pin-Spiral
6	717-0526	Shaft-Worm
7	717-0528	Gear-Worm
8	718-0186	Collar-Thrust
9	721-0325	Plug
10	721-0327	Seal-Oil
11	736-0351	Washer-Flat
12	736-0369	Washer-Flat
13	736-0445	Washer-Flat
14	737-0168	Grease
15	741-0662	Bearing-Flange
16	741-0663	Bearing-Flange
17	618-0120A	Assembly, Complete 24"

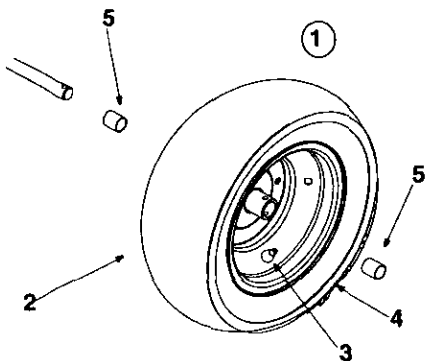

Key No.	Part No.	Description
1.	634-0114	Wheel Assembly, Complete
2.	734-1732	Tire
3.	734-0255	Air Valve
4.	734-1713	Rim
5.	741-0401	Sleeve Bearing

NOTE: For painted parts, please refer to the list of color codes below. Please add the applicable color code, wherever needed, to the part number to order a replacement part. For instance, if a part, numbered 700-xxxx, is painted polo green, the part number to order would be 700-xxxx-0689.

Polo Green: 0689
 Powder Black: 0637
 Oyster Gray: 0662

SEARS CRAFTSMAN 5.0 H.P. SNOW THROWER MODEL 247.886640

IMPORTANT: For a proper working machine, use Factory Approved Parts. **V-BELTS** are specially designed to engage and disengage safely. A substitute (non OEM) V-Belt can be dangerous by not disengaging completely.

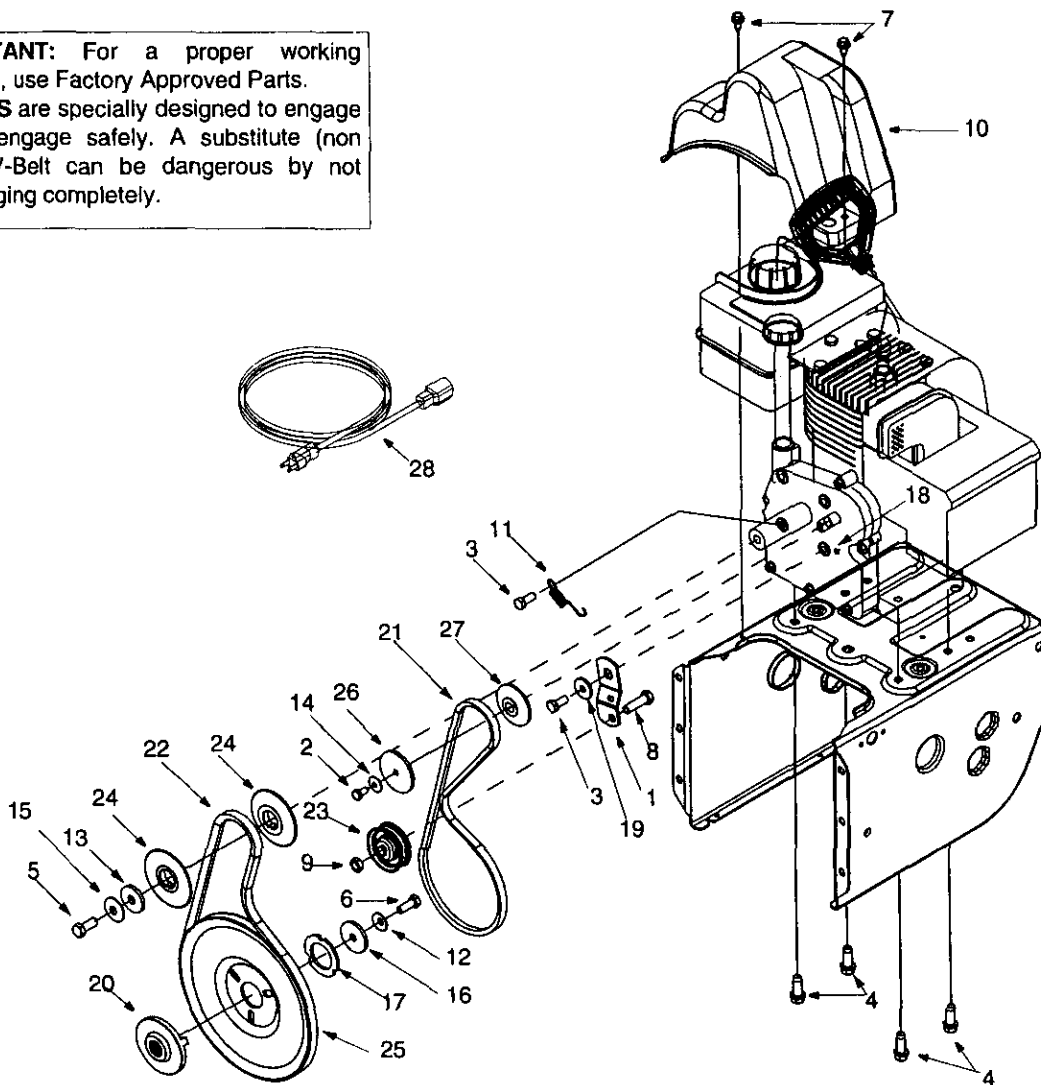

Key No.	Part No.	Description	Qty.	Key No.	Part No.	Description	Qty.
1.	05896A	Idler Bracket	1	17.	736-0507	Special Washer	1
2.	710-0230	Hex Bolt 1/4-28 x 0.50"	1	18.	737-3007	Grease	—
3.	710-0627	Hex Bolt: Lock 5/16-24 x .750"	2	19.	748-0234	Shoulder Spacer	1
4.	710-0654A	Self-Tapping Sems Screw	4	20.	748-0360	Pulley: Adapter	1
5.	710-0696	Hex Bolt 3/8-24 x .875"	1	21.	754-0343	V-Belt	1
6.	710-1245	Hex Bolt : Lock 5/16-24 x .875"	1	22.	754-0430A	Belt	1
7.	710-1652	Self-Tapping Screw	2	23.	756-0313	Idler: Flat	1
8.	710-3005	Hex Screw 3/8-16 x 1.25"	1	24.	756-0569	Pulley: Half	2
9.	712-0181	Jam Nut	1	25.	756-0967	Auger Pulley	1
10.	731-1324	Belt Cover	1	26.	756-0984	Pulley Half	1
11.	732-0339	Extension Spring	1	27.	756-0985	Pulley Half	1
12.	736-0242	Beleville Washer	1	28.	629-0071	Extension Cord	1
13.	736-0247	Flat Washer	1	29.	—	Engine, Craftsman model 143.015007	1
14.	736-0270	Bell Washer	1	30.	770-10433	Operator's Manual (not shown)	1
15.	736-0331	Bell Washer	1				
16.	736-0505	Flat Washer	1				

SEARS CRAFTSMAN 5.0 H.P. SNOW THROWER MODEL 247.886640

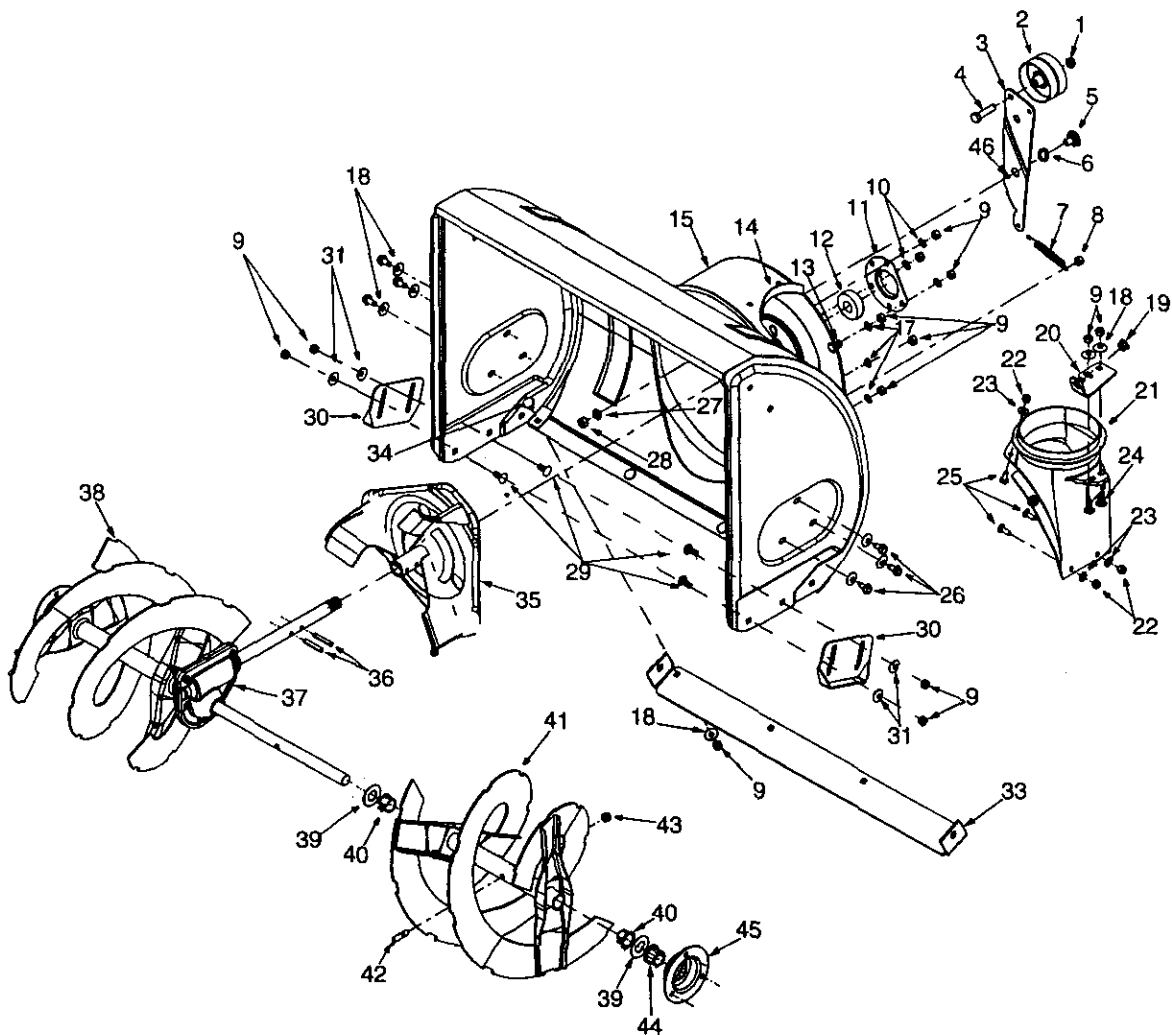

NOTE: For painted parts, please refer to the list of color codes below. Please add the applicable color code, wherever needed, to the part number to order a replacement part. For instance, if a part, numbered 700-xxxx, is painted polo green, the part number to order would be 700-xxxx-0689.

Polo Green:	0689
Powder Black:	0637
Oyster Gray:	0662

SEARS CRAFTSMAN 5.0 H.P. SNOW THROWER MODEL 247.886640

Key No.	Part No.	Description	Qty.	Key No.	Part No.	Description	Qty.
1	712-0116	Lock Jam Nut 3/8-24	1	24	710-0451	Carriage Bolt	6
2	756-0178	Flat Idler	1	25	710-0703	Carriage Screw 1/4-20 x .75	1
3	784-5632A	Auger Idler Arm	1	26	710-0604	Hex Washer Screw 5/16-18	1
4	710-0459A	Hex Cap Screw 3/8-24 x 1.50	1	27	736-0169	Lock Washer 3/8	4
5	738-0281	Shoulder Screw	1	28	712-0798	Hex Nut 3/8-16	2
6	736-0167	Flat Washer	1	29	710-0451	Carriage Bolt 5/16-18 x .75	4
7	732-0611	Extension Spring	1	30	784-5580	Skid Shoe	2
8	712-3068	Hex Nut 5/16-18	1	31	736-0242	Bell Washer	4
9	712-3010	Hex Nut 5/16-18	13	33	784-5581A	Shave Plate	1
10	736-0119	Lock Washer 5/16	9	34	710-0260	Carriage Bolt 5/16-18 x .62	2
11	05931	Bearing Housing	1	35	684-0065	Impeller Assembly	1
12	741-0309	Ball Bearing	1	36	715-0114	Roll Pin	2
13	710-0451	Carriage Bolt 5/16-18	4	37*	618-0120A	Gear Assembly	1
14	705-5226	Reinforcement Chute	1	38	605-5188A	Spiral RH	1
15	684-0039C	Housing Assembly	1	39	736-0188	Flat Washer	4
17	736-0119	Lock Washer 5/16	13	40	741-0493A	Flange Bushing	4
18	736-0242	Bell Washer	10	41	605-5189A	Spiral LH	1
19	741-0475	Bushing	1	42	710-0890A	Shear Bolt 5/16-18 x 1.5	2
20	784-5647	Chute Crank Bracket	1	43	712-0429	Lock Nut 5/16-18	2
21	731-1379B	Chute Adapter	5	44	741-0245	Hex Flange Bearing	2
22	712-0324	Hex Lock Nut 1/4-20	5	45	784-5618	Bearing Housing	1
23	736-0463	Flat Washer	5	46		Grease	—

* See page 22 for breakdown of this assembly.

SEARS CRAFTSMAN 5.0 H.P. SNOW THROWER MODEL 247.886640

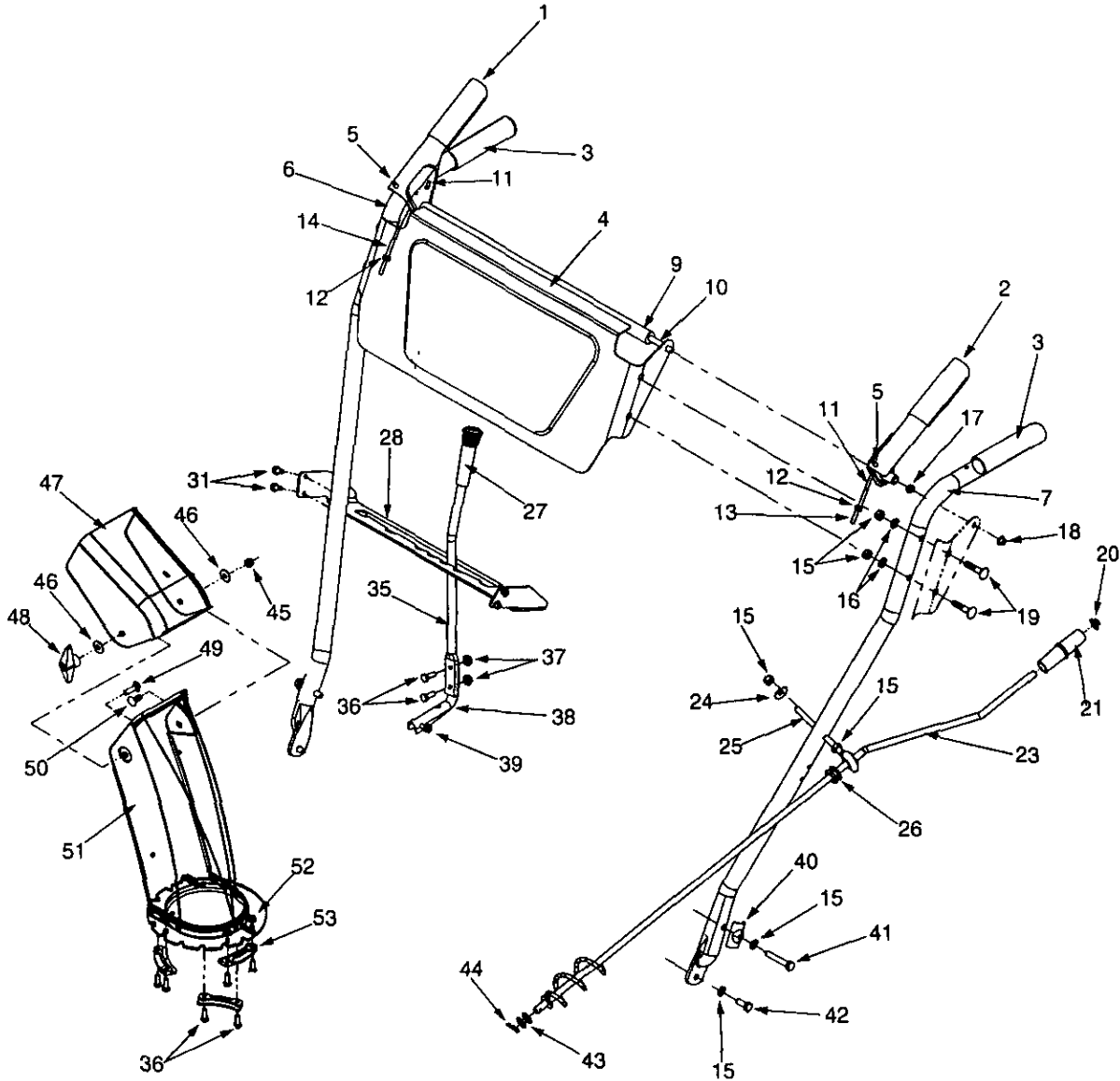

NOTE: For **paint**ed parts, please refer to the list of color codes below. Please add the applicable color code, wherever needed, to the part number to order a replacement part. For instance, if a part, numbered 700-xxxx, is painted polo green, the part number to order would be 700-xxxx-0689.

Polo Green:	0689
Powder Black:	0637
Oyster Gray:	0662

SEARS CRAFTSMAN 5.0 H.P. SNOW THROWER MODEL 247.886640

Key No.	Part No.	Description	Qty.	Key No.	Part No.	Description	Qty.
1	705-5234	Clutch Lever Assembly - RH	1	26	735-0234	Rubber Grommet	1
2	705-5233	Clutch Lever Assembly - LH	1	27	720-0223	Grip	1
3	720-0274	Grip	2	28	705-5231	Speed Selector Plate	1
4	784-5717	Handle Panel Assembly	1	31	710-0599	Hex Wash. Screw 1/4-20 x .50	4
5	735-0199A	Bumper	2	35	747-0904	Shift Lever	1
6	749-0910B	Handle RH	1	36	710-3015	Hex Cap Screw 1/4-20 x .75	8
7	749-0911B	Handle LH	1	37	712-3027	Hex Lock Nut 1/4-20	8
9	731-1500	Pivot Rod Cover	1	38	732-0733	Shift Lever Support	1
10	747-0984	Pivot Rod	1	39	710-0788	Hex Washer	1
11	746-0778	"Z" Fitting	2	40	784-5599	Handle Tab	2
12	712-0121	Hex Nut	2	41	710-3180	Hex Cap Screw 5/16-18 x 1.75	2
13	746-0897	Auger Clutch Cable	1	42	710-3008	Hex Cap Screw 5/16-18 x .75	2
14	746-0898	Drive Clutch Cable	1	43	736-0185	Flat Washer 3/8 ID x .738 OD	2
15	712-3010	Hex Nut 5/16-18	8	44	714-0104	Cotter Pin	1
16	736-0119	Lock Washer 5/16	8	45	712-0429	Hex Lock Nut 5/16-18	3
17	750-1032	Spacer	2	46	736-0159	Washer 5/16	2
18	726-0135	Push Cap	2	47	731-0921	Upper Chute	1
19	710-0262	Carriage Bolt 5/16-18 x 1.5	4	48	720-0284	Wing Knob 5/16-18	1
20	726-0100	Push Cap	1	49	710-0276	Carriage Screw 5/16-18 x 1.0	1
21	720-0201A	Chute Crank Knob	1	50	710-0451	Carriage Bolt 5/16-18 x .75	3
23	705-5204A	Chute Crank Assembly	1	51	731-1300A	Lower Chute	1
24	736-0242	Bell Washer .340 ID x .873 OD	3	52	712-3027	Hex Lock Nut 1/4-20	6
25	747-0697	Eyebolt	1	53	731-0851A	Chute Flange Keeper	3

SEARS CRAFTSMAN 5.0 H.P. SNOW THROWER MODEL 247.886640

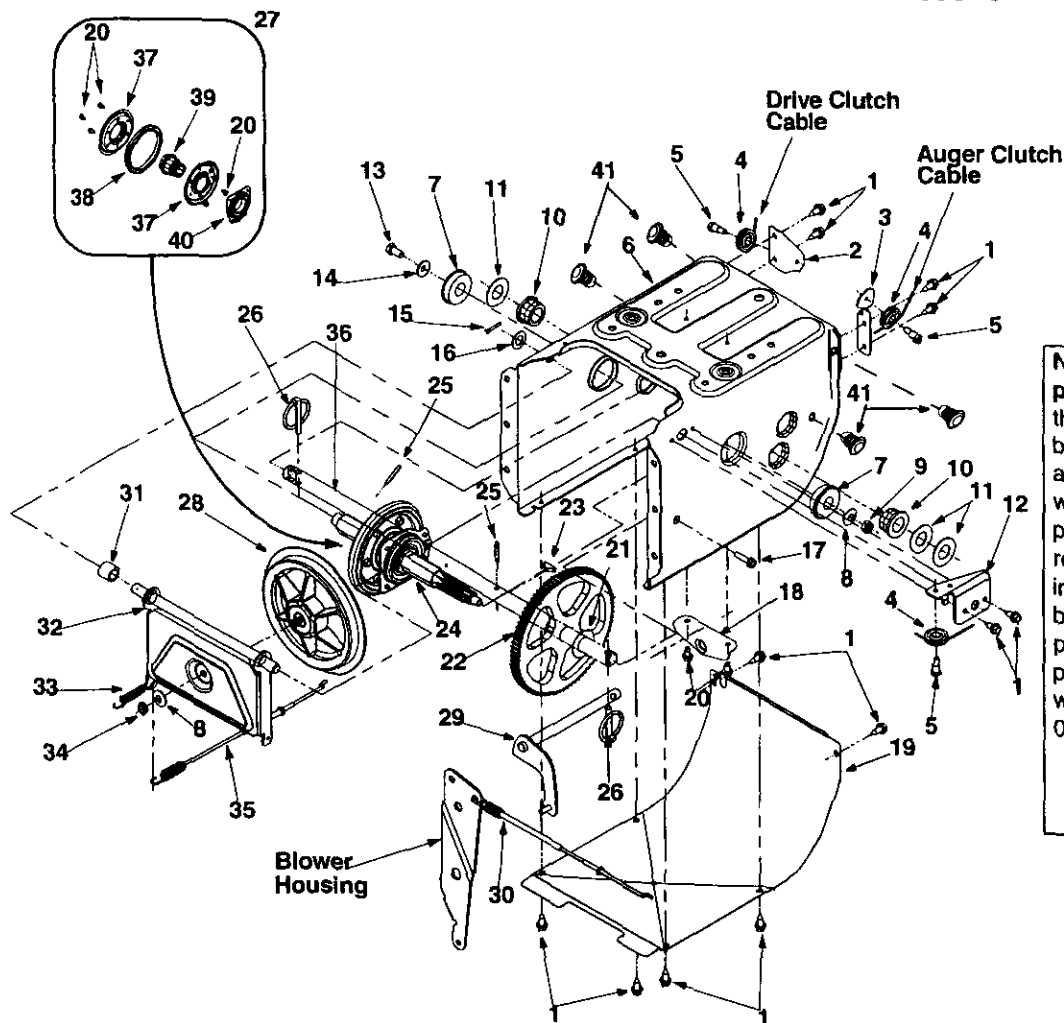

NOTE: For painted parts, please refer to the list of color codes below. Please add the applicable color code, wherever needed, to the part number to order a replacement part. For instance, if a part, numbered 700-xxxx, is painted polo green, the part number to order would be 700-xxxx-0689.

Polo Green: 0689
 Powder Black: 0637
 Oyster Gray: 0662

Key No.	Part No.	Part Description	Qty.	Key No.	Part No.	Part Description	Qty.
1	710-1652	Hex Screw	8	22	717-1445	Gear	1
2	784-5688	Drive Cable Guide Bracket	1	23	714-0126	Key	1
3	784-5687A	Auger Clutch Cable Bracket	1	24	717-1444	7-Tooth Shaft	1
4	756-0625	Roller Cable	3	25	715-0249	Roll Pin	2
5	738-0924	Hex Screw 1/4-28	3	26	714-0143	Klik Pin	2
6	684-0030	Frame Assembly	1	27	684-0042C	Friction Wheel Assembly	1
7	741-0563	Ball Bearing	2	28	656-0012A	Friction Disc Wheel	1
8	736-0105	Bell Washer	2	29	684-0013B	Wheel Shift Rod Assembly	1
9	712-0116	Lock Jam Nut	1	30	746-0897	Auger Cable	1
10	741-0598	Hex Flange Bearing	2	31	748-0190	Spacer	1
11	736-0188	Flat Washer	3	32	684-0021	Friction Wheel Bracket Assy.	1
12	784-5689A	Front Support Guide Bracket	1	33	732-0264	Extension Spring	1
13	710-0538	Lock Hex Screw	1	34	712-0711	Jam Nut 3/8-24	1
14	736-0242	Bell Washer .340 ID x .872 OD	1	35	746-0898	Drive Cable	1
15	714-0474	Cotter Pin	1	36	738-0869	Axle 13" Wheels	1
16	736-0160	Flat Washer .536 ID x .930 OD	1	37	784-5617A	Friction Plate	1
17	710-0788	Hex Washer Screw 1/4-20	1	38	735-0243	Friction Wheel Rubber	1
18	784-5590	Frame Shift Bracket	1	39	718-0301A	Friction Wheel Hub	1
19	784-5638	Frame Cover	1	40	618-0063	Friction Wheel Bearing	1
20	710-0599	Hex Washer Screw 1/4-20	6	41	712-0703	Nut Insert	4
21	736-0351	Flat Washer .760 ID x .50 OD	1				

CRAFTSMAN ENGINE 143.015007 FOR SNOW THROWER MODEL 247.886640

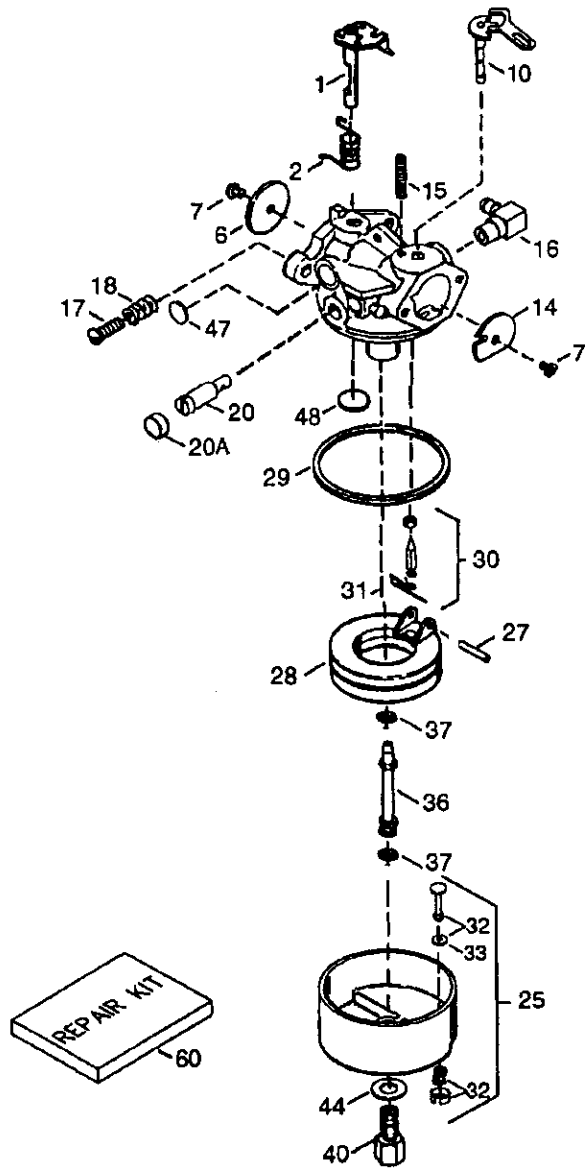

Key No.	Part No.	Description	Qty.
0	640084A	Carburetor (Incl. 184 on page 33)	1
1	631615	Throttle Shaft & Lever Assembly	1
2	631767	Throttle Return Spring	1
6	640070	Throttle Shutter	1
7	650506	Shutter Screw	2
10	632108	Choke Shaft & Lever Assembly	1
14	631890	Choke Shutter	1
15	630735	Choke Positioning Spring	1
16	631807	Fuel Fitting	1
17	651025	Throttle Crack Screw/Idle Speed Screw	1
18	630766	Tension Spring	1
20	640027	Idle Restrictor Screw	1
20A	640053	Idle Restrictor Screw Cap	1
25	631951	Float Bowl Ass'y (Incl. 32 & 33)	1
27	631024	Float Shaft	1
28	632019	Float	1
29	631028	Float Bowl "O" Ring	1
30	631021	Inlet Needle, Seat & Clip (Incl. 31)	1
31	631022	Spring Clip	1
32	27136A	Bowl Drain Assembly	1
33	27554	Drain Plunger Gasket	1
36	632745	Main Nozzle Tube	1
37	632547	"O" Ring, Main Nozzle Tube	2
40	640183	High Speed Bowl Nut	1
44	27110A	Bowl Nut Washer	1
47	630748	Welch Plug, Idle Mixture Well	1
48	631027	Welch Plug, Atmospheric Vent	1
60	632760	Repair kit	1

CRAFTSMAN ENGINE 143.015007 FOR SNOW THROWER MODEL 247.886640

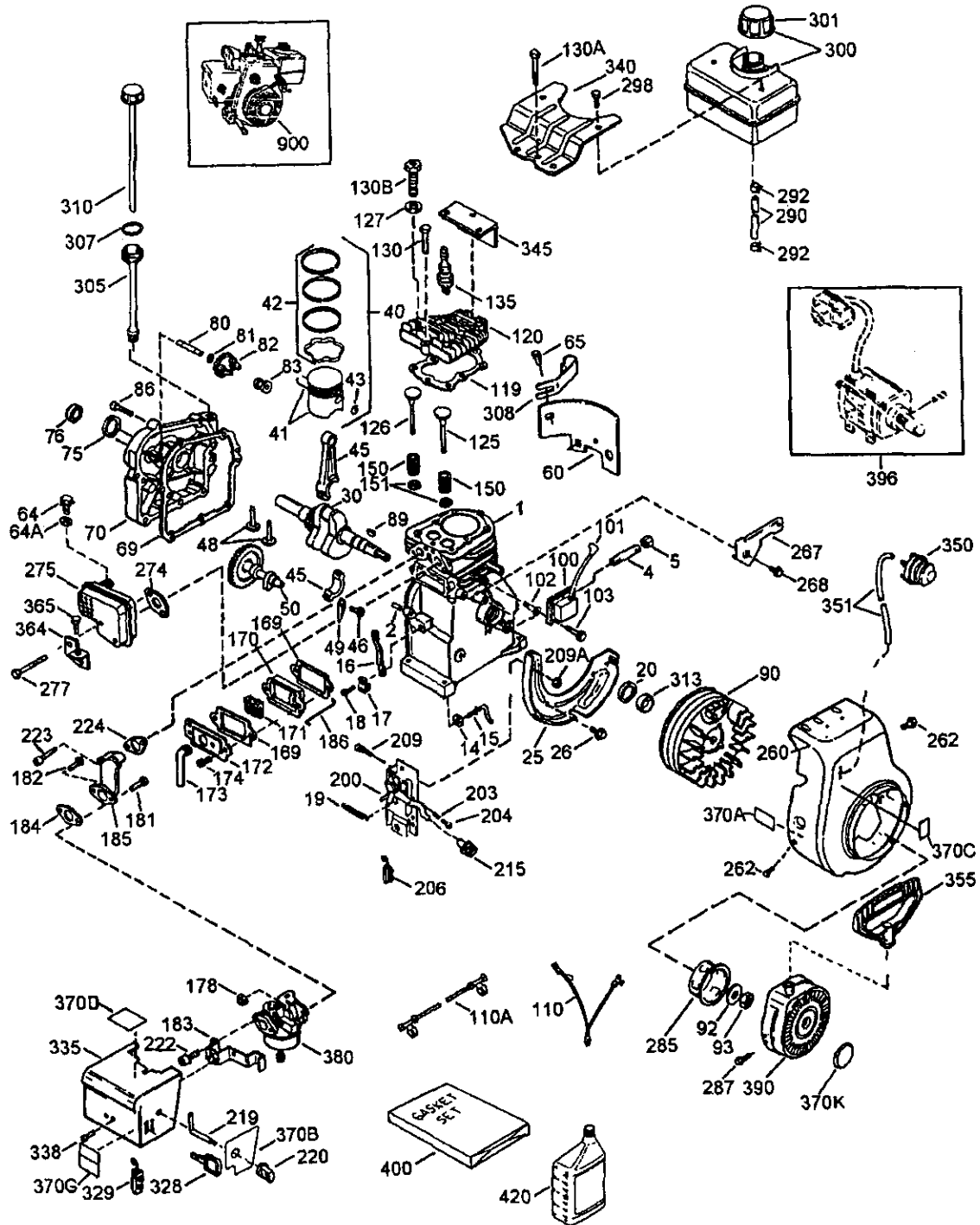

CRAFTSMAN ENGINE 143.015007 FOR SNOW THROWER MODEL 247.886640

Key No.	Part No.	Description	Qty.	Key No.	Part No.	Description	Qty.
0		RPM High 3450 to 3750	0	110	35182	Ground Wire	1
0		RPM Low 1850 to 2150	0	110A	36874	Ground Wire	1
1	36469A	Cylinder (Incl. 2,20,72 & 125)	1	119	36443	Cylinder Head Gasket	1
2	26727	Dowel Pin	2	120	36441	Cylinder Head (Incl. 131)	1
4	0	Oil Drain Extn. (Purchase Local)	1	125	36471	Exhaust Valve (Std.) (Incl. 151)	1
5	30969	Extension Cap	1	125	36472	Exhaust Val. (1/32" OS) (Incl. 151)	1
14	28277	Washer	1	126	32644A	Intake Valve (Std.) (Incl. 151)	1
15	31334	Governor Rod	1	126	32645A	Intake Valve (1/32" OS) (Incl. 151)	1
16	31510	Governor Lever	1	127	650691	Washer	1
17	31335	Governor Lever Clamp	1	130	6021A	Screw, 5/16-18 x 1-1/2"	2
18	651018	Screw, Torx T-15, 8-32 x 19/64"	1	130A	650694A	Screw, 5/16-18 x 2"	5
19	31426	Extension Spring	1	130B	650818	Screw, 5/16-18 x 1-1/2"	1
20	32600	Oil Seal	1	135	35395	Resistor Spark Plug (RJ19LM)	1
25	36552	Blower Housing Baffle (Incl. 262)	1	150	31672	Valve Spring	2
26	650802	Screw, 1/4-20 x 5/8"	2	151	31673	Valve Spring Cap	2
30	35975	Crankshaft	1	169	27234A	Valve Cover Gasket	2
40	36073	Piston, Pin & Ring Set (Std.)	1	170	27666	Breather Body	1
40	36074	Piston, Pin & Ring Set (.010" OS)	1	171	31410	Breather Element	1
40	36075	Piston, Pin & Ring Set (.020" OS)	1	172	34146	Valve Cover	1
41	36070	Piston & Pin Ass'y. (Std.) (Incl. 43)	1	173	35350	Breather Tube	1
41	36071	Piston & Pin Ass'y. (.010" OS) (Incl. 43)	1	174	650783	Screw, 10-24 x 3/4"	2
41	36072	Piston & Pin Ass'y. (.020" OS) (Incl. 43)	1	178	29752	Nut & Lock Washer, 1/4-28"	2
42	36076	Ring Set (Std.)	1	181	650870	Screw, 1/4-28 x 1-11/16"	1
42	36077	Ring Set (.010" OS)	1	182	6201	Screw, 1/4-28 x 7/8"	1
42	36078	Ring Set (.020" OS)	1	183	34583A	Choke Bracket	1
43	20381	Piston Pin Retaining Ring	2	184	26756	Carburetor To Intake Pipe Gasket	1
45	32875A	Connect. Rod Ass'y. (Incl. 46, 49)	1	185	33691	Intake Pipe	1
46	32610A	Connecting Rod Bolt	2	186	32698	Governor Link	1
48	27241	Valve Lifter	2	200	36677	Control Bracket (Incl. 203-209A)	1
49	32654	Oil Dipper	1	203	31342	Compression Spring	1
50	36650	Camshaft (BCR)	1	204	651029	Screw, Torx T-15, 5-40 x 7/16"	1
60	29745	Blower Housing Extension	1	206	610973	Terminal	1
64	30063	Screw, Torx T-30, 1/4-20 x 1/2"	1	209	650139	Screw, 8-32 x 3/4"	2
64A	8345	Washer	1	209A	30322	Lock Nut, 8-32	2
65	650128	Screw, 10-24 x 1/2"	1	215	35440	Control Knob	1
69	27677A	Cylinder Cover Gasket	1	219	34582	Choke Rod	1
70	34678A	Cylinder Cover (Incl. 75 thru 83)	1	220	35438	Choke Knob	1
75	27897	Oil Seal	1	222	28820	Screw, 10-32 x 1/2"	2
76	30318	Camshaft Seal	1	223	650664	Screw, 1/4-20 x 1-19/32"	2
80	30574A	Governor Shaft	1	224	33673A	Intake Pipe Gasket	1
81	30590A	Washer	1	260	35656A	Blower Housing	1
82	30591	Governor Gear Ass'y. (Incl. 81)	1	262	650737	Screw, 1/4-20 x 1/2"	2
83	30588A	Governor Spool	1	267	34212	Hold Down Bracket	1
86	650488	Screw, 1/4-20 x 1-1/4"	7	268	30200	Screw, 10-24 x 9/16"	1
89	610961	Flywheel Key	1	274	33670A	Exhaust Gasket	1
90	611199	Flywheel (W/Ring Gear)	1	275	35771	Muffler (Incl. 274)	1
92	650815	Belleville Washer	1	277	650327	Screw, 1/4-20 x 2-27/64"	2
93	650816	Flywheel Nut	1	285	36467A	Starter Cup	1
100	34443B	Solid State Ignition	1	287	650926	Screw, 8-32 x 21/64"	2
101	610118	Spark Plug Cover	1	290	30705	Fuel Line	1
102	651024	Solid State Mounting Stud	2	292	26460	Fuel Line Clamp	4
103	651007	Screw, Torx T-15, 10-24 x 15/16"	2	298	650665	Screw, 1/4-15 x 3/4"	2
				300	35584	Fuel Tank (Incl. 292 & 301)	1
				301	35355	Fuel Cap	1

Table continued on next page

CRAFTSMAN ENGINE 143.015007 FOR SNOW THROWER MODEL 247.886640

Table continued from previous page:

Key No.	Part No.	Description	Qty.
305	35554	Oil Fill Tube	1
307	35499	Oil Fill Tube "O" Ring	1
308	35539	Oil Fill Tube Clip	1
310	35556	Dipstick Ass'y.	1
313	34080	Spacer	1
328	35062	Ignition Key	2
329	610973	Terminal	1
335	35072	Carburetor Cover	1
338	650257	Screw, 8-32 x 5/16"	2
340	36247	Fuel Tank Bracket	1
345	33344	Heat Baffle	1
350	570682A	Primer Ass'y.	1
351	32180C	Primer Line	1
355	590574	Starter Handle (Mitten Grip)	1
364	33333	Carburetor Cover Bracket	1
365	650735	Screw, 10-24 x 3/8"	1
370A	36261	Lubrication Decal	1
370B	35282	Instruction Decal	1
370C	36501	Primer Decal	1
370D	35878	Warning Decal	1
370G	36534	Instruction Decal	1
370K	36695	Starter Decal	1
380	640084A	Carburetor (Incl. 184)	1
390	590742	Rewind Starter	1
396	33290E	Electric Starter	1
400	36444	Gasket Set (Incl. Items Marked PK in Notes)	1
420	730226	SAE 5W30 4-Cycle Engine Oil (Quart)	1
900	754303	Replacement Short Block, Order From 71-999	1

CRAFTSMAN ENGINE 143.015007 FOR SNOW THROWER MODEL 247.886640

Recoil Starter

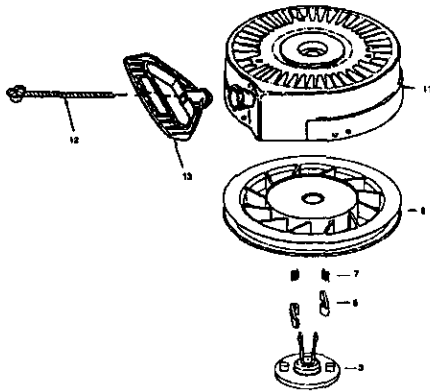

Key No.	Part No.	Description	Qty.
0	590742	Rewind Starter	1
3	590740	Retainer	1
6	590616	Starter Dog	2
7	590617	Dog Spring	2
8	590645A	Pulley & Rewind Spring Ass'y	1
11	590647	Starter Housing Ass'y	1
12	590535	Starter Rope (Length 98" x 9/64" dia.)	1
13	590574	Mitten Grip Handle (Not included w/starter)	1
14	590760	Spring Clip	1

Electric Starter

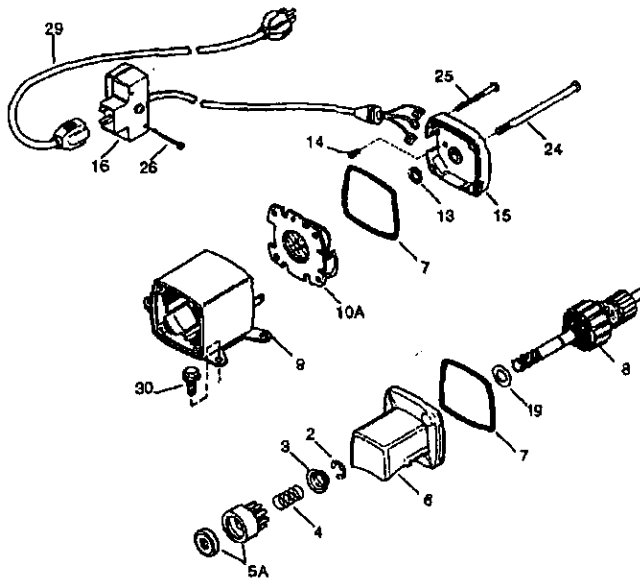

Key No.	Part No.	Description	Qty.
0	33290E	Electric Starter (110 Volt)	1
2	31749	Retainer Ring	1
3	33522	Spring Retainer	1
4	33769	Anti-drift Spring	1
5A	37332	Nut & Gear (Incl. 2)	1
6	35461	Drive End Cap Ass'y. (Incl. 7)	1
7	35450	"O" Ring	2
8	35912	Armature	1
9	0	Housing Ass'y. (Must Purchase Complete Motor)	1
10A	35452A	Brush & Spring Card Ass'y.	1
13	590500	Thrust Washer	1
14	33441	Ground Screw	1
15	35453	Commutator End Cap Ass'y. (Incl. 7)	1
16	35454	Switch Box Ass'y.	1
19	35911	Thrust Washer	0
24	35462	Case Bolt	2
25	35456	Grounding Screw	1
26	650819	Screw, 6-32 x 2-1/2"	2
26	651032	Screw, 12-16 x 5/8"	2
29	32450B	Extension Cord (10'6")	1
30	650759	Screw, Torx T-30, 1/4-20 x 23/32"	3