

Panasonic®

DVD Home Theater Sound System

Operating Instructions

Model No.

SC-HT80

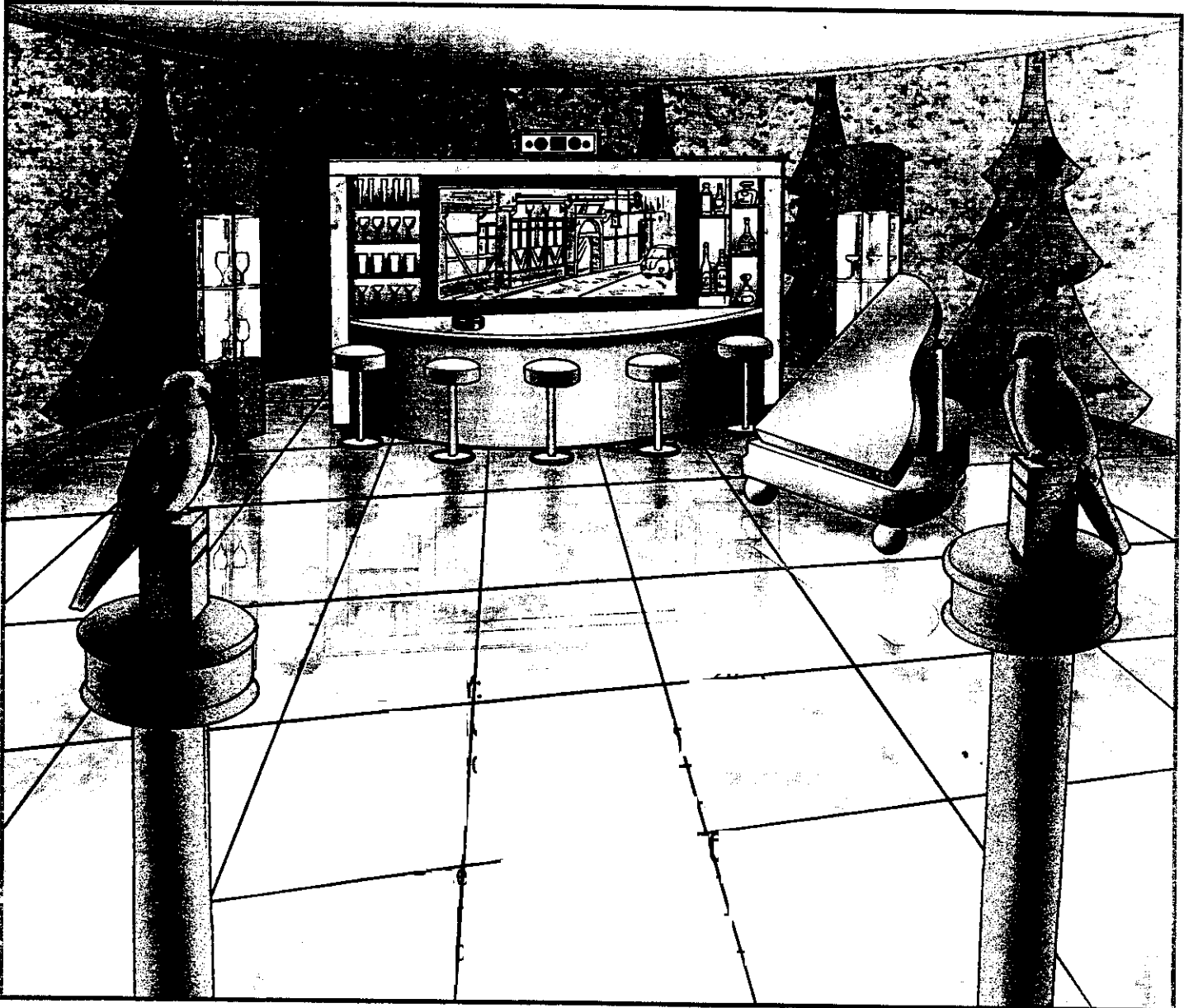
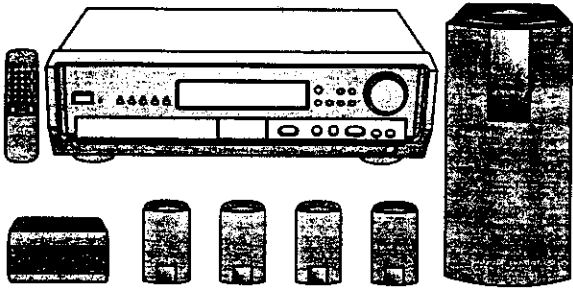

DVD
VIDEO

COMPACT
disc
DIGITAL VIDEO

COMPACT
disc
DIGITAL AUDIO

Before connecting, operating or adjusting this product, please read these instructions completely.
Please keep this manual for future reference.

P PC

RQT5235-1P

Dear Customer

Thanks you for purchasing this product.
For optimum performance and safety, please read these instructions carefully.

System	SC-HT80
Main unit	SA-HT80
Front and surround speakers	SB-AFC80
Center speaker	SB-AFC285
Subwoofer	SB-W80

CAUTION!

**THIS PRODUCT UTILIZES A LASER.
USE OF CONTROLS OR ADJUSTMENTS OR
PERFORMANCE OF PROCEDURES OTHER THAN THOSE
SPECIFIED HEREIN MAY RESULT IN HAZARDOUS
RADIATION EXPOSURE.
DO NOT OPEN COVERS AND DO NOT REPAIR YOURSELF.
REFER SERVICING TO QUALIFIED PERSONNEL.**

WARNING:

**TO REDUCE THE RISK OF FIRE, ELECTRIC
SHOCK OR PRODUCT DAMAGE, DO NOT
EXPOSE THIS APPLIANCE TO RAIN,
SPLASHING, DRIPPING OR MOISTURE.**

CAUTION:

**TO PREVENT ELECTRIC SHOCK MATCH WIDE
BLADE OF PLUG TO WIDE SLOT, FULLY
INSERT.**

User memo:

DATE OF PURCHASE _____
DEALER NAME _____
DEALER ADDRESS _____
TELEPHONE NUMBER _____

The model number and serial number of this product can be found on either the back or the bottom of the unit. Please note them in the space provided below and keep for future reference.

MODEL NUMBER SC-HT80
SERIAL NUMBER _____

DANGER	LASER RADIATION WHEN OPEN AVOID DIRECT EXPOSURE TO BEAM.
DANGER	RADIATION LASER LORSQUE OUVERT. EVITER TOUTE EXPOSITION AU FAISCEAU.
ADVARSEL	LASERSTRÅLING VED ÅPNING. UNNGÅ UDSÆTTELSE FOR STRÅLING.
VARO!	AVATTIÄSSÄ JA SUOJALUKUTUS OHITETTAESSA OLET ALLTIMNA LASERSÄTELYLLE. ÄLÄ KATSO SÄTEESEEN.
VARNING	LASERSTRÅLNING NÄR DENNA DEL ÄR ÖPPNAD OCH SPÄRREN ÄR URKOPPLAD. BETRÄKTA EJ STRÅLEN.
ADVARSEL	LASERSTRÅLING NÄR DENSEL ÅPNES OG SIKKERHEDSÅS BRYTES. UNNGÅ EKSPONERING FOR STRÅLEN.
VORSICHT	LASERSTRÄHLUNG, WENN ABDECKUNG GEÖFFNET NICHT DEM STRAHL AUSSETZEN.

(inside of product)
(Intérieur de l'appareil)
(Innersiden at apparatet)
(Tuotteen sisällä)
(Apparatens insida)
(Produktets insida)
(Im Inneren des Gerätes)

Region numbers



Region numbers are allocated to DVD players and software according to where they are sold.

- The region number for this unit is "1".
- This unit can play DVD with or including the region number [1] and [All].

Type of discs

This system can play back discs bearing any of the marks:



This system does not have a DTS decoder so it cannot play audio encoded with DTS.

This system can not play the following discs

- DVD with a region number other than [1] or [All]
- DVD audio
- PAL system discs
- DVD-ROM
- DVD-R
- DVD-RAM
- DVD+RW
- DIVX Video Disc
- CD-ROM
- VSD
- CDV
- CD-G
- CD-RW
- CVD
- SACD
- SVCD
- CD-R
- Photo CD etc.

Disc symbols used in these operating instructions

The functions you can use depend on the type of disc you play. These marks are used to indicate which type of disc is explained.



Feature can be used with DVD



Feature can be used with video CD



Feature can be used with audio CD

Some features cannot be used even if these symbols are indicated.

Before use

Precautions	4
Supplied accessories	5
Concerning the remote control	6
DVD symbols	7
Karaoke discs	7
Speaker set-up	8
Connections	10
Front panel controls	12

Preparations

Television settings	14
---------------------------	----

Disc operations

Playing discs	15
Other methods of play	17
Using the resume function to restart play	17
Pause (Still picture)	17
Search function	17
Skip function	18
Frame-by-frame viewing	18
Slow-motion play	18
Repeat function	19
Marking a position	20
Title menu	21
DVD menu	21
Changing soundtracks	22
Changing subtitle language	22
Switching angles	23
Starting play from a specific track	23
Random play	24
Using the Disc Manager	24
Program play	25
Using GUI screens	26
GUI icon descriptions	28

Radio operations

The radio: manual tuning	30
The radio: preset tuning	31
Automatic presetting	31
Selecting channels	31

Sound quality/sound field operations

Sound field	32
Sound field effects you can enjoy with this unit	32
Enjoying sound with Dolby Digital	34
Enjoying sound with Dolby Pro Logic	34
Enjoying sound with stereophonics (SUPER SRND)	36
Enjoying sound with simulated stereo (SIMULATED ST)	36
To down mix to 2 channels	36
Using the virtual rear surround effect (VIRTUAL REAR SRND)	37
Using the multi rear surround effect (MULTI REAR SRND)	37
Using the center focus effect (CENTER FOCUS)	37
Using the seat position function (SEAT POSITION)	38
Sound Field Control effects	38

Other functions

Timer function	39
Setting the timer	39
Convenient functions	40
To mute the volume	40
To turn off the unit's display	40
To listen through headphones	40
Adjusting the bass	40
Using other equipment	41
Listening to an external source	41
Recording to other equipment	41
Using the remote control with other equipment	42
Operating a television	42
Operating a video deck	42
Changing the remote control code	43

Reference

Initial settings	44
Concerning discs	49
When moving the unit	49
Glossary	50
Maintenance	51
Listening caution	51
Troubleshooting	52
Specifications	54
Product Service	55

	CAUTION RISK OF ELECTRIC SHOCK DO NOT OPEN	
CAUTION: TO REDUCE THE RISK OF ELECTRIC SHOCK, DO NOT REMOVE SCREWS. NO USER-SERVICEABLE PARTS INSIDE. REFER SERVICING TO QUALIFIED SERVICE PERSONNEL.		

 The lightning flash with arrowhead symbol, within an equilateral triangle, is intended to alert the user to the presence of uninsulated "dangerous voltage" within the product's enclosure that may be of sufficient magnitude to constitute a risk of electric shock to persons.

 The exclamation point within an equilateral triangle is intended to alert the user to the presence of important operating and maintenance (servicing) instructions in the literature accompanying the appliance.

Before use

Before using this unit please read these operating instructions carefully. Take special care to follow the warnings indicated on the unit itself as well as the safety suggestions listed below. Afterwards keep them handy for future reference.

Safety

- 1. Power Source** — The unit should be connected to power supply only of the type described in the operating instructions or as marked on the unit.
- 2. Polarization** — If the unit is equipped with a polarized AC power plug (a plug having one blade wider than the other), that plug will fit into the AC outlet only one way. This is a safety feature. If you are unable to insert the plug fully into the outlet, try reversing the plug. If the plug should still fail to fit, contact your electrician to replace your obsolete outlet. Do not defeat the safety purpose of the polarized plug.
- 3. Power Cord Protection** — AC power supply cords should be routed so that they are not likely to be walked on or pinched by items placed upon or against them. Never take hold of the plug or cord if your hand is wet, and always grasp the plug body when connecting or disconnecting it.
- 4. Nonuse Periods** — When the unit is not used, turn the power off. When left unused for a long period of time, the unit should be unplugged from the household AC outlet.

Installation

Environment

- 1. Outdoor Antenna Grounding** — If an outside antenna is connected to the receiver, be sure the antenna system is grounded so as to provide some protection against voltage surges and built-up static charges. Section 810 of the National Electrical Code, ANSI/NFPA No. 70-1990, provides information with respect to proper grounding of the mast and supporting structure, grounding of the lead-in wire to an antenna discharge unit, size of grounding conductors, location of antenna-discharge unit, connection to grounding electrodes, and requirements for the grounding electrode. See figure below.

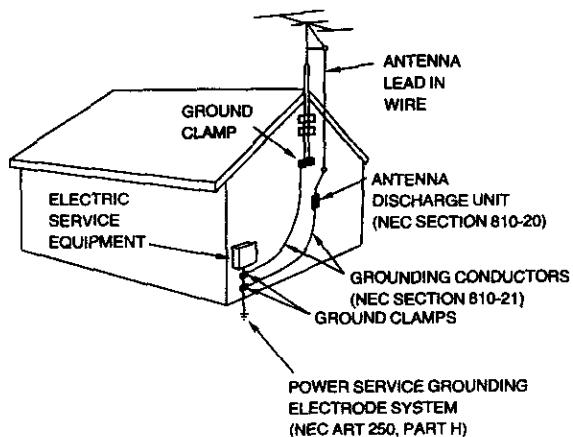

NEC—NATIONAL ELECTRICAL CODE

- 2. Water and Moisture** —Do not use this unit near water—for example, near a bathtub, washbowl, swimming pool, or the like. Damp basements should also be avoided.

- 3. Heat** —The unit should be situated away from heat sources such as radiators and the like. It also should not be placed in temperatures less than 5°C (41°F) or greater than 35°C (95°F).
- 4. Condensation** —Moisture may form on the lens in the following conditions...
 - immediately after a heater has been turned on.
 - in a steamy or very humid room.
 - when the unit is suddenly moved from a cold environment to a warm one.
 If moisture forms inside this unit, it may not operate properly. To correct this problem, turn on the power and wait about one hour for the moisture to evaporate.

Placement

- 1. Ventilation** —The unit should be situated so that its location or position does not interfere with its proper ventilation. Allow 10 cm (4") clearance from the rear of the unit.
- 2. Foreign Material** —Care should be taken so that objects do not fall into and liquids are not spilled into the unit. Do not subject this unit to excessive smoke, dust, mechanical vibration, or shock.
- 3. Magnetism** —The unit should be situated away from equipment or devices that generate strong magnetic fields.
- 4. Stacking** —Do not place heavy objects, other than system components, on top of the unit.
- 5. Surface** —Place the unit on a flat, level surface.
- 6. Carts and Stands** —The unit should be used only with a cart or stand that is recommended by the manufacturer. The unit and cart combination should be moved with care. Quick stops, excessive force, and uneven surfaces may cause the unit and cart combination to overturn.
- 7. Wall or Ceiling Mounting** —The unit should not be mounted to a wall or ceiling, unless specified in this operating instructions.





Maintenance

(See page 51 for details.)

Clean the cabinet, panel and controls with a soft cloth lightly moistened with mild detergent solution. Do not use any type of abrasive pad, scouring powder or solvent such as alcohol or benzene.

Service

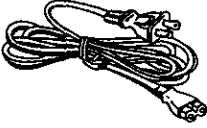
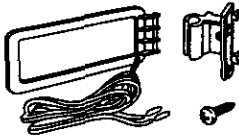
- 1. Damage Requiring Service** — The unit should be serviced by qualified service personnel when:
 - (a) The AC power supply cord or the plug has been damaged; or
 - (b) Objects have fallen or liquid has been spilled into the unit; or
 - (c) The unit has been exposed to rain; or
 - (d) The unit does not appear to operate normally or exhibits a marked change in performance; or
 - (e) The unit has been dropped, or the enclosure damaged.
- 2. Servicing** — The user should not attempt to service the unit beyond that described in the operating instructions. All other servicing should be referred to an authorized service personnel.
For the address of an authorized servicer:
In the U.S.A. 1-800-211-7262 or web site
(http://www.panasonic.com)
In Canada 905-624-5505 or web site
(www.panasonic.ca)

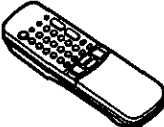
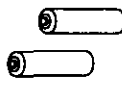
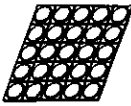
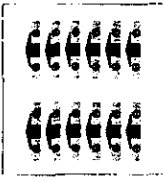
A <input type="checkbox"/> 
B <input type="checkbox"/> 
C <input type="checkbox"/> 
D <input type="checkbox"/> 
E <input type="checkbox"/> 
F <input type="checkbox"/> 
G <input type="checkbox"/> 
H <input type="checkbox"/> 

Supplied accessories

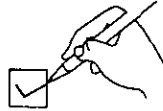

Please check and identify the supplied accessories.

- A** AC power supply cord 1
(RJA0065-A)
- B** AM loop antenna set 1
(RSA0012)
- C** FM indoor antenna 1
(RSA0006-J)
- D** Video connection cable 1
(RJL1P016B15A)
- E** Remote control transmitter 1
(EUR51964)
- F** Batteries 2
- G** Speaker feet 1 sheet (25 feet)
(RFA0631A-K)
* Replacements sold in 1-sheet lots (4 feet per sheet).
- H** Speaker stickers 1 sheet (2 sets)
* One set is extra. These sheets cannot be purchased separately.

Use numbers indicated in parentheses when asking for replacement parts.

(Only for U.S.A.)

To order accessories contact 1-800-332-5368 or web site (<http://www.panasonic.com>).

Before use

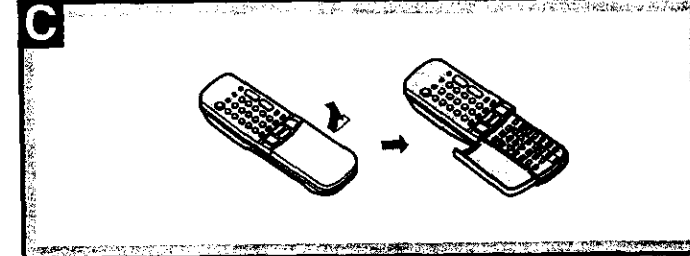
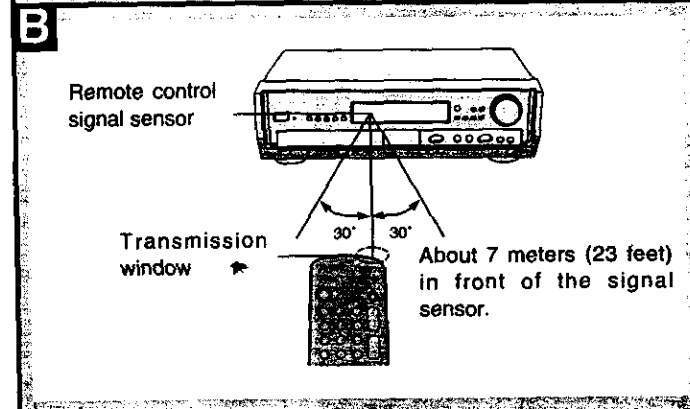
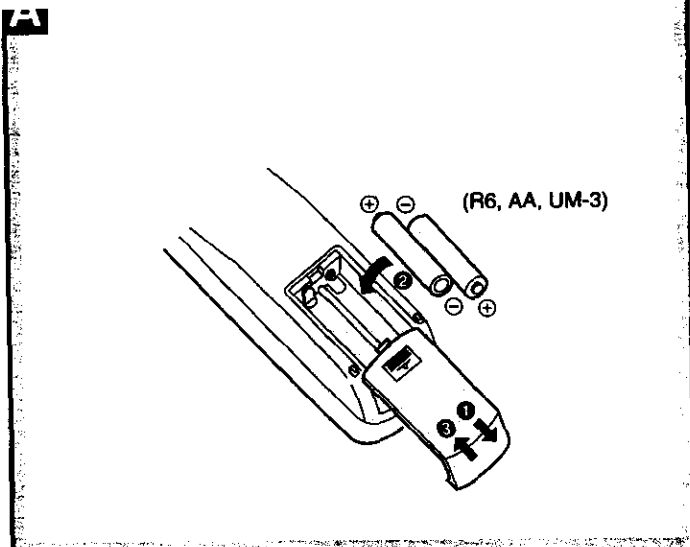

A Battery installation

Use of batteries

- Align the poles (+ and -) properly when inserting the batteries. Press in and down towards the minus end.
- Do not mix old and new batteries, or batteries of different types.
- Do not recharge ordinary dry cell batteries.
- Do not heat or disassemble the batteries. Do not allow them to contact flame or water.
- Remove the batteries if the unit is not to be used for a long time.
- Do not keep together with metallic objects such as necklaces.
- Do not use batteries if the covering has been peeled off.
- Do not use rechargeable type batteries.

Mishandling of batteries can cause electrolyte leakage which can damage items the fluid contacts and may cause a fire. If electrolyte leaks from the batteries, consult your dealer. Wash thoroughly with water if electrolyte comes in contact with any part of your body.

B Correct method of use

Operation notes

- Do not place obstacles between the remote control signal sensor and remote control unit.
- Do not expose the remote control signal sensor to direct sunlight or to the bright light of a fluorescent light.
- Take care to keep the remote control signal sensor and end of the remote control unit free from dust.
- If this system is installed in a rack with glass doors, the glass doors' thickness or color might make it necessary to use the remote control a shorter distance from the system.





To prevent damage

- Never place heavy items on top of the unit.
- Do not disassemble or reconstruct the unit.
- Do not spill water or other liquids into the unit.

C How to open the remote control

Symbols shown on DVD jackets

These are examples of the symbols shown on the back of DVD jackets.

<p>Region number</p> 	<p>The region number is a method of protecting the rights of the producer of the material. A DVD cannot be played if its region number doesn't match the region number of the player. This unit can play DVD with or including the region number "1" and "All".</p>
<p>Audio recording method</p> 	<p>The left side tells you which method was used for recording. This example is of a disc that was recorded using Dolby Digital 5.1 channel surround. This unit cannot play audio recorded using dts.</p>
<p>Multi-angle</p> 	<p>This indicates the software was filmed from multiple angles at the same time. The number tells you the number of angles.</p>
<p>Screen size</p> 	<p>These symbols tell you which screen format was used to film the software.</p>

Karaoke discs

Some discs are structured differently.

5 channel DVD	
	Audio stream number 1
1 ch	Left side stereo accompaniment
2 ch	Right side stereo accompaniment
3 ch	Guide melody (the melody of the vocal section)
4 ch	Vocals 1
5 ch	Vocals 2

Video CD, etc.	
1 ch	Monastral accompaniment
2 ch	Monastral accompaniment and vocals

2 channel DVD		
	Audio stream number 1	Audio stream number 2
1 ch	Left side stereo accompaniment	Left side stereo accompaniment and Vocals
2 ch	Right side stereo accompaniment	Right side stereo accompaniment and Vocals

Before use

* Refer also to "Speaker set-up", a separate guide included with these operating instructions.

1 Attach the stickers to the speaker cords

The 4 small speakers are the same.

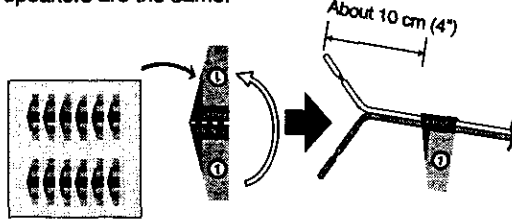

Attach the stickers to the speaker cords.

- ① - ④ : Attach stickers 1 to 4 to the cords of the 4 small speakers (2 x front and 2 x surround: SB-AFC80).
- ⑤ : Attach sticker 5 to the cord of the medium-sized speaker (center speaker: SB-AFC285).
- ⑥ : Attach sticker 6 to the cord of the large speaker (subwoofer: SB-W80).

2 Attach the rubber feet to the speaker

The four small speakers and the medium speaker can be set-up either standing or lying down. Attach these rubber feet to prevent vibration causing the speakers to move or fall over.

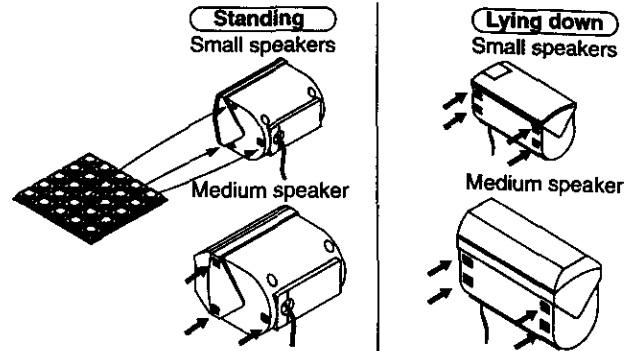

3 Position the speakers

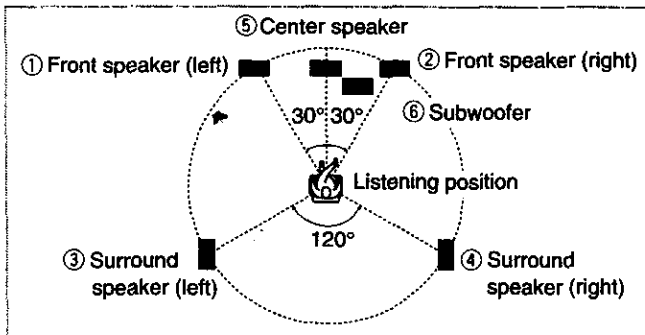

- ① - ⑥ : Position the speakers as indicated in the diagram using the stickers as a guide.

* The front, center, and surround speakers should be placed at approximately the same distance from the listening position. The angles in the diagram are approximate.

- Place the front left and right speakers (①, ②) either side of the television.
- Place the center speaker (⑤) directly above the television.
- Place the surround speakers (③, ④) either side of the listening position, or slightly to the rear, about 1 meter (3 feet) higher than ear level.
- The subwoofer (⑥) can be placed anywhere as long as it is not too far from the television.

Note

If you are unable to position the surround speakers as recommended, you can put them near the front speakers and still achieve a surround-like effect (⇒ "Virtual rear surround", page 33).

4 Connect the speakers to the unit

Speakers cords

- Connect the cords so the numbers on the stickers match the numbers under the terminals.
- Connect the gray cords with the blue stripe ⊖ to the blue terminals.
- Connect the gray cords without stripes ⊕ to the gray terminals.
- Connect the subwoofer's red cord to the red terminal ⊕ and the black cord to the black terminal ⊖.
- Ensure the wires of the cords are fully inserted so they do not touch each other and short circuit.

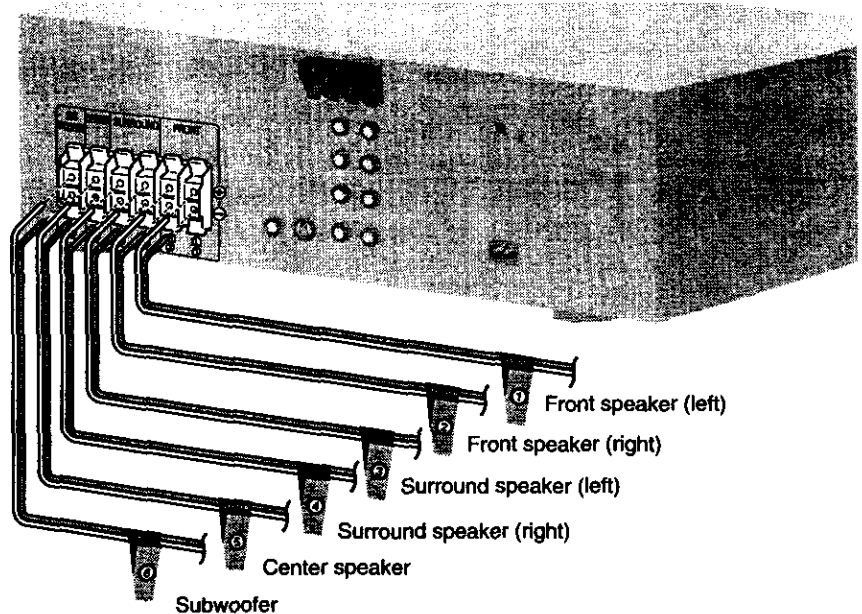
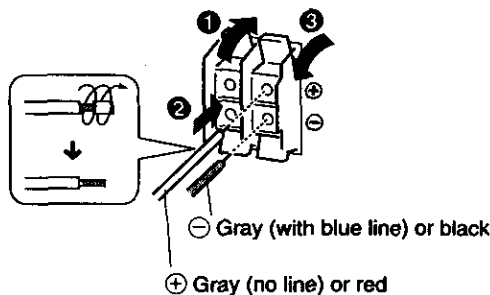

Note

After you have completed set-up and connection, wind the excess cord and keep together with string.

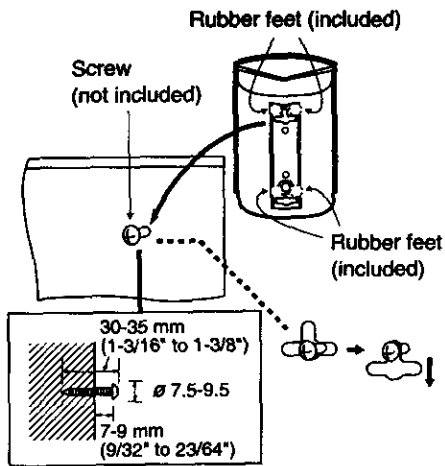
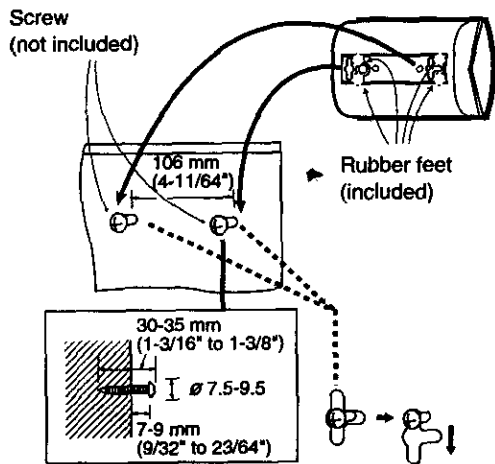
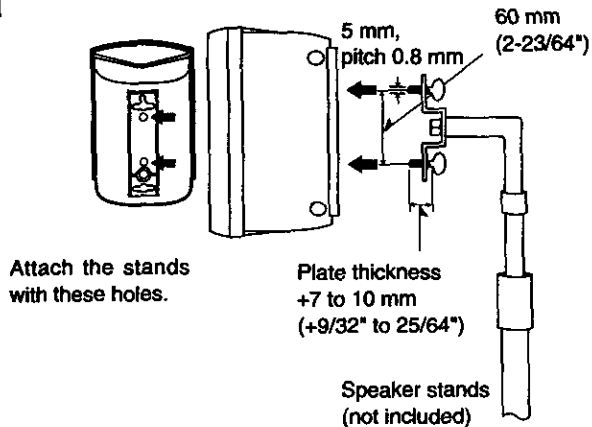
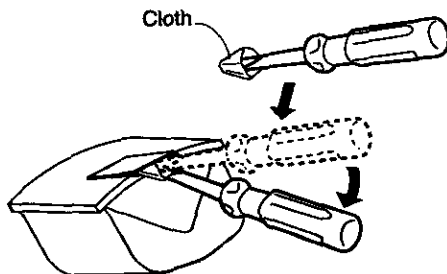
A**B****C****D****Speaker set-up****Attaching to a wall**

- A** To attach vertically
- B** To attach horizontally

* Attach four rubber feet to each speaker, ensuring they do not cover the holes.

Note

The surface you attach the speakers to must be able to support over 10 kg (22 lb.).

C Attaching to speaker stands**Note**

Ensure the following conditions are met when you purchase your speaker stands.

- Observe the diameter and length of the screws and the distance between screws as shown in the diagram.
- The stands must be able to support over 10 kg (22 lb.).
- The stands must be stable even if the speakers are in a high position.

D Moving the brand plate

You can rotate the brand plate if you choose to set up the small speakers horizontally.

(Prevent damage to the plate by wrapping the end of the screwdriver with cloth.)

Insert the screwdriver under the plate and lift it. Rotate the plate to the required position.

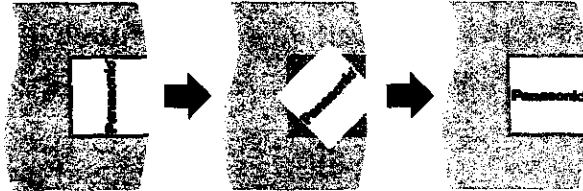
**If irregular coloring occurs on your television**

These speakers are designed to be used close to a television, but the picture may be affected with some televisions and set-up combinations.

If this occur, turn the television off for about 30 minutes.

The television's demagnetizing function should correct the problem.

If it persists, move the speakers further away from the television.

Note

- Set the speakers up on an even surface to prevent them from falling. Take proper precautions to prevent the speakers from falling if you cannot set them up on an even surface.
- The speaker nets cannot be removed.
- Keep your speakers at least 10 mm (13/32") away from the system for proper ventilation.

**Caution**

- Use the speakers only with the recommended system. Failure to do so may lead to damage to the amplifier and/or the speakers, and may result in the risk of fire. Consult a qualified service person if damage has occurred or if you experience a sudden change in performance.
- Do not attempt to attach these speakers to walls using methods other than those described in this manual.

Before use

Connecting the indoor antennas, television, and power

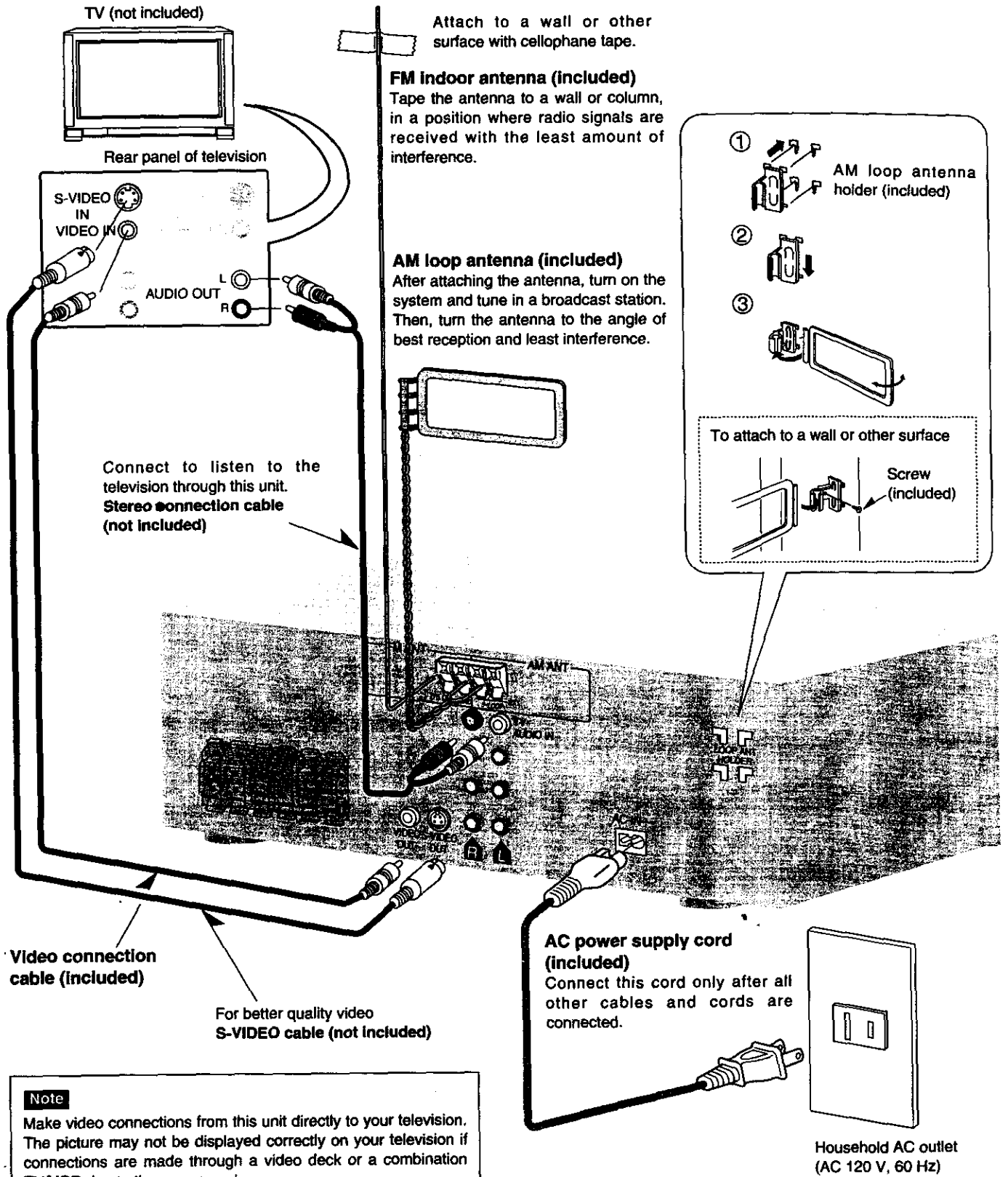

Note
Make video connections from this unit directly to your television. The picture may not be displayed correctly on your television if connections are made through a video deck or a combination TV/VCR due to the copy guard.

Note
The included AC power supply cord is for use with this unit only. Do not use it with other equipment.

Connecting other equipment

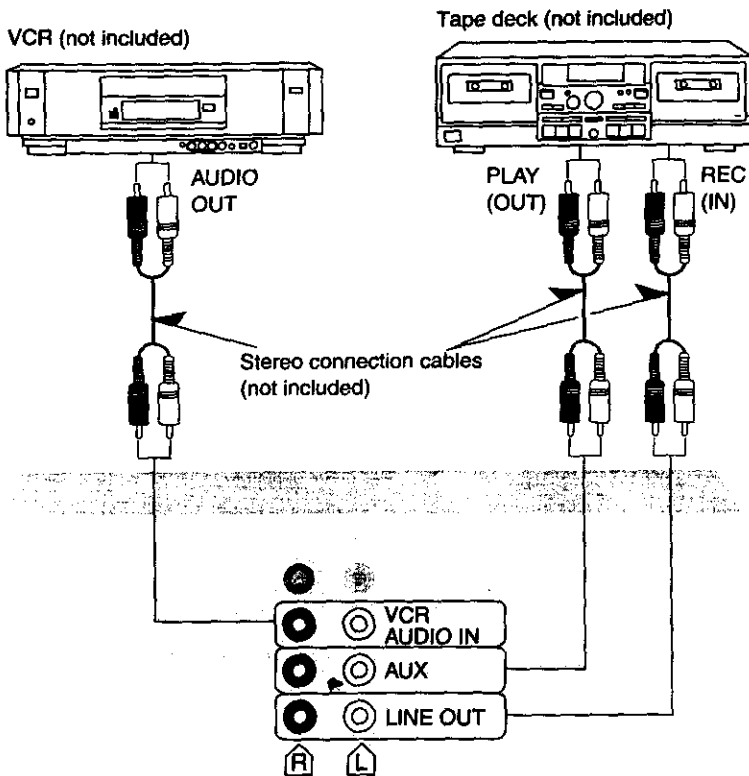

These are examples of connection. You can connect other recording equipment instead of a cassette deck. A record player, laser disc player, etc. can be connected to the AUX terminals.

To connect a record player

Connect the record player to a phono equalizer to amplify the signal, then connect the phono equalizer to the AUX terminals.

Note

Audio output through LINE OUT is only from sources played in this unit (radio and discs), not from other sources connected to TV AUDIO IN, VCR AUDIO IN, and AUX.

Outdoor antenna connections

Use outdoor antennas if radio reception is poor.

FM outdoor antenna (Using a television antenna)

Disconnect the FM indoor antenna.

An outdoor antenna should be installed by a qualified technician only.

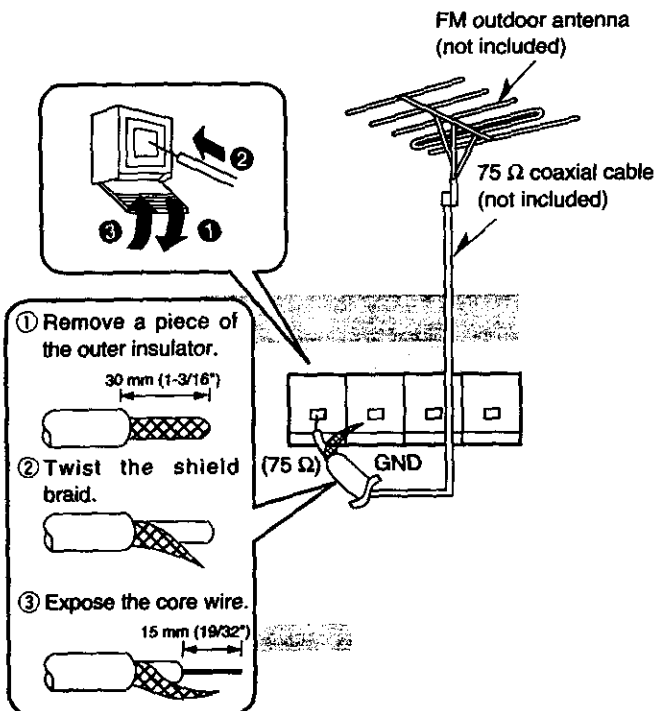

AM outdoor antenna (Using a vinyl wire)

Run a piece of vinyl wire horizontally across a window or other convenient location.

Leave the loop antenna connected.

When the unit is not in use, disconnect the outdoor antenna to prevent possible damage that may be caused by lightning. Never use an outdoor antenna during an electrical storm.

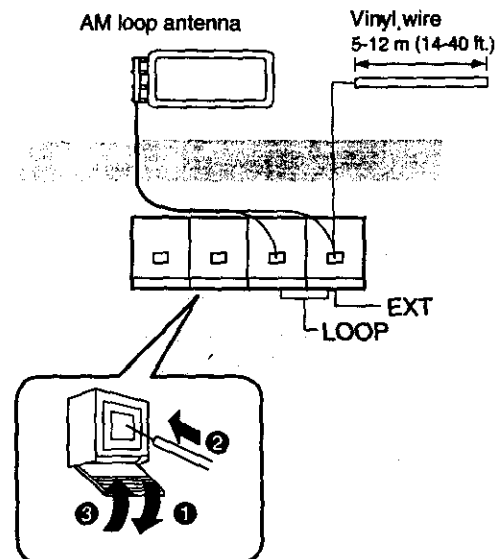

Before use

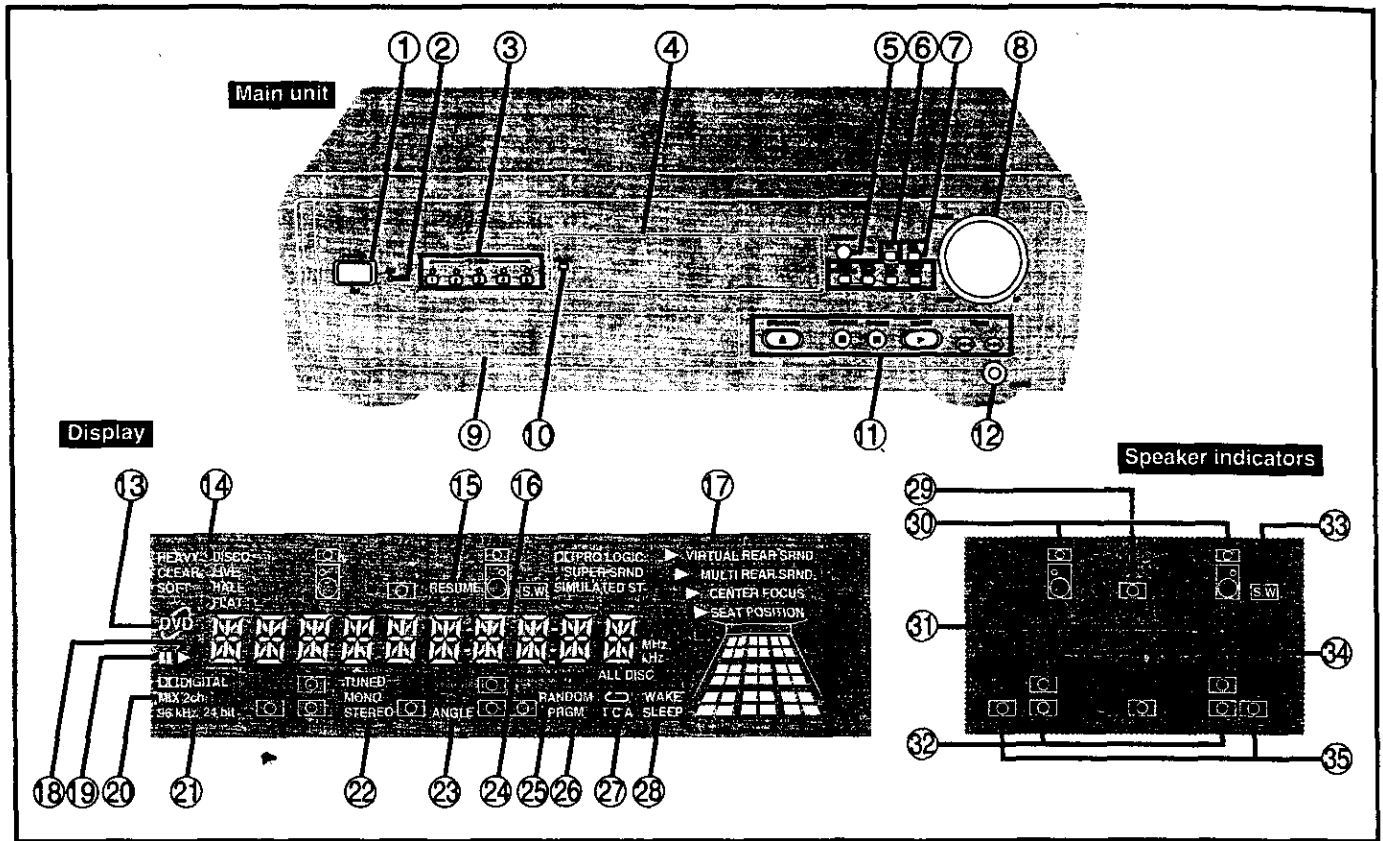

No.	Name	Ref.page
-----	------	----------

Main unit

- ① **Power “ ⏻ / ⏻ ” switch (POWER, ⏻ / ⏻).....14**
Press to switch the unit from on to standby mode or vice versa. In standby mode, the unit is still consuming a small amount of power.
- ② **Standby/on indicator (⏻ / ⏻)**
The indicator lights green when the unit is turned on. When the AC power supply is used, it functions as an AC connection indicator. (The indicator color changes to red when the unit is turned off.)
- ③ **Disc select buttons (5 DISC).....15**
- ④ **Display**
- ⑤ **Input select button (SELECTOR)15**
- ⑥ **Sound field effect buttons.....34, 37, 38**
- ⑦ **Subwoofer level button (SUBWOOFER LEVEL)40**
- ⑧ **Volume control (VOLUME)16**
- ⑨ **Disc tray**
- ⑩ **Wake timer indicator (WAKE)39**
- ⑪ **Basic operation buttons**
- ⑫ **Headphones jack (PHONES).....40**

Display

- ⑬ **DVD disc indicator16**
Lights when DVD is loaded.
- ⑭ **SFC mode indicator38**
- ⑮ **Resume indicator.....17**
- ⑯ **General display**
- ⑰ **Surround effect indicator34-38**

No.	Name	Ref.page
-----	------	----------

- ⑱ **Play indicator16**
- ⑲ **Pause (Still picture) indicator17**
- ⑳ **MIX 2ch indicator36**
- ㉑ **DVD disc signal indicator16**
- ㉒ **Radio indicator30**
- ㉓ **Angle indicator23**
- ㉔ **All disc indicator24**
- ㉕ **Random indicator24**
- ㉖ **Program indicator25**
- ㉗ **Repeat indicator19**
- ㉘ **Timer indicator39**

Speaker indicators

- ㉙ **Center speaker (Blue)**
- ㉚ **Surround speakers (Blue)**
Lights when VIRTUAL REAR SURROUND is on.37
- ㉛ **Front speaker (Blue)**
- ㉜ **Surround speakers (Blue)**
- ㉝ **Subwoofer (Blue)40**
- ㉞ **Surround speakers (Orange)**
Lights when MULTI REAR SURROUND is on.37
- ㉟ **Surround speakers (Orange)**
Lights when VIRTUAL REAR SURROUND is on.37

Blue indicator: Sound is actually coming from the speaker.
Flashing blue indicator: A test signal is being output for the speaker.
Orange indicator: Virtual speaker. Sound seems to come from the position indicated.

Remote control

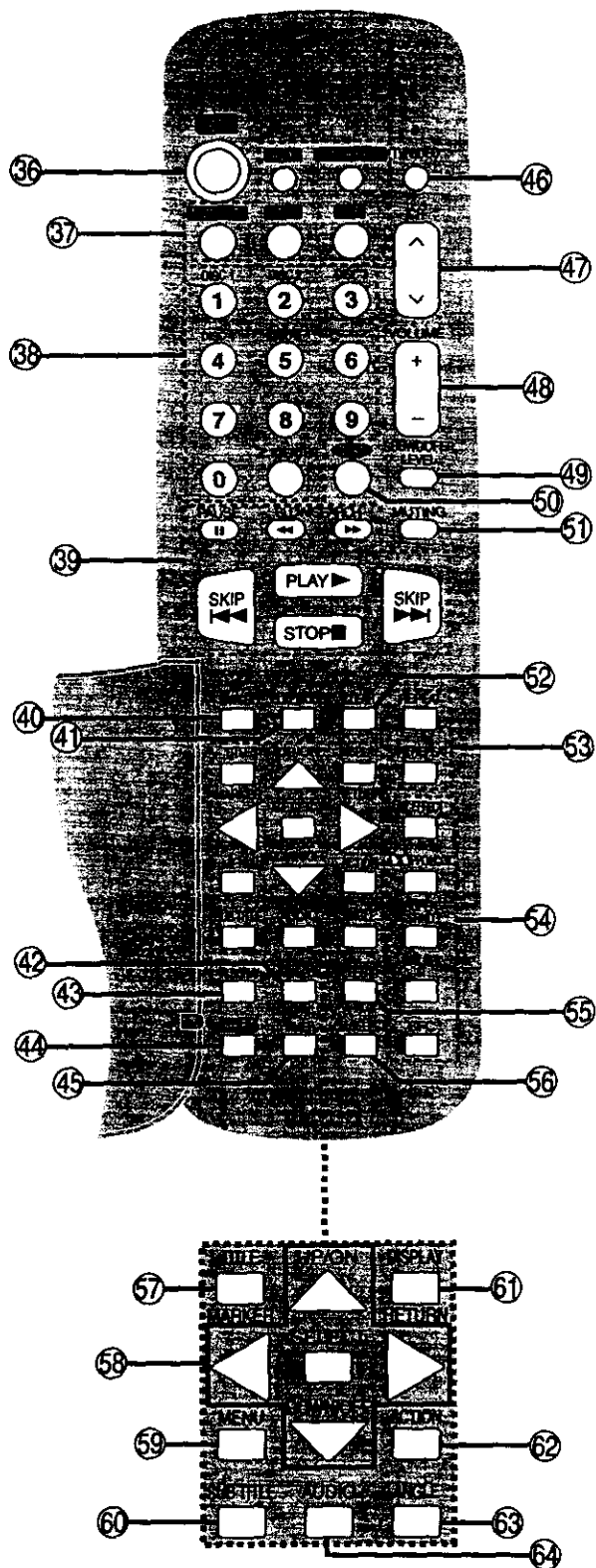

No.	Name	Ref. page
36	Power button (⏻)	
37	Input select buttons (AUX, TUNER/BAND, DVD/CD, TV, VCR) TUNER/BAND button is also used to switch radio bands.	
38	Numbered buttons and ≥10/enter button (1-9, 0, ≥10/ENTER)	14-16
39	Basic operation buttons	
40	Disc manager button (DISC MANAGER)	24
41	Play mode button (PLAY MODE)	24
42	MIX 2ch down mix button (MIX 2ch).....	36
43	FL display button (FL DISPLAY).....	40
44	Shift button (SHIFT)	20
45	Timer button (TIMER).....	39
46	TV/video select button (TV/VIDEO).....	42
47	Channel up/down button (CH ^, v)	31
48	Volume button (VOLUME +, -)	16
49	Subwoofer level button (SUBWOOFER LEVEL)	40
50	Disc button (DISC)	23
51	Muting button (MUTING)	40
52	Clear button (CLEAR)	20
53	Repeat buttons (REPEAT, A-B REPEAT).....	19
54	Sound field effect buttons.....	34-38
55	Test button (TEST).....	35
56	Speaker channel select button (CH SELECT)	35
57	Title, marker button (TITLE, MARKER)	20, 21
58	Cursor and select buttons	
59	Menu button (MENU)	21
60	Subtitle language select button (SUB TITLE)	22
61	Display, return button (DISPLAY, RETURN)	26, 46
62	Initial settings button (ACTION)	14
63	Angle button (ANGLE).....	23
64	Soundtrack language display button (AUDIO)	22

Before use

television settings

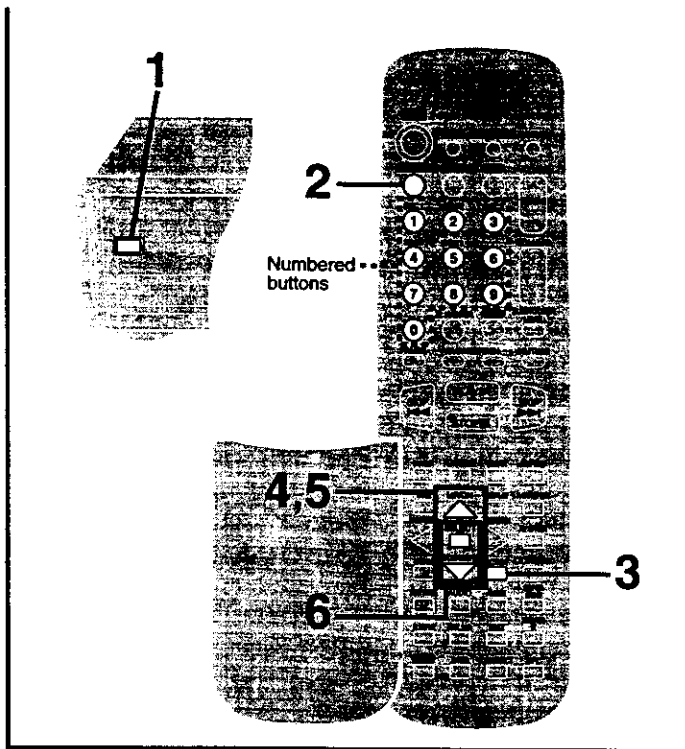

The menu language has been factory preset to English. You can change the language by going to "3 Menu Language".
(→ page 44)

Set the screen size to suit your television. The initial setting is for a regular television with an aspect ratio of 4:3. You do not have to change the setting if you have this kind of television.

Preparation

- Turn the television on.
- Switch the video input mode on the television to suit the type of connection you have made (e.g., VIDEO 1).

1 Press [POWER, $\phi/1$] to turn the unit on.

2 Press [DVD/CD] to select "DVD/CD" as the source.

3 Press [ACTION] to display the initial settings screen on the television.

4 Press [UP/ON \triangle] or [DOWN/OFF ∇] to highlight "5 TV Aspect", and press [SELECT].

5 Press [UP/ON \triangle] or [DOWN/OFF ∇] to highlight the required size, and press [SELECT].

4:3: regular television

16:9: widescreen television

The initial settings screen is shown after you make your selection.

6 While the initial settings screen is on the television Press [DOWN/OFF ∇] to highlight "0 Exit", and press [SELECT].

Steps 4 to 6 can also be done with the numbered buttons.

Press the number next to the required item.

For example, in step 4, press button number 5.

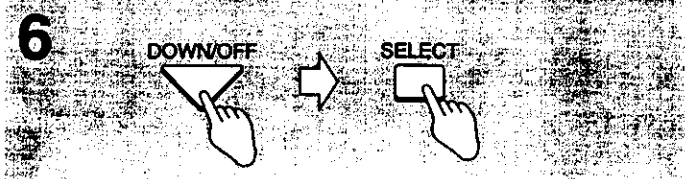
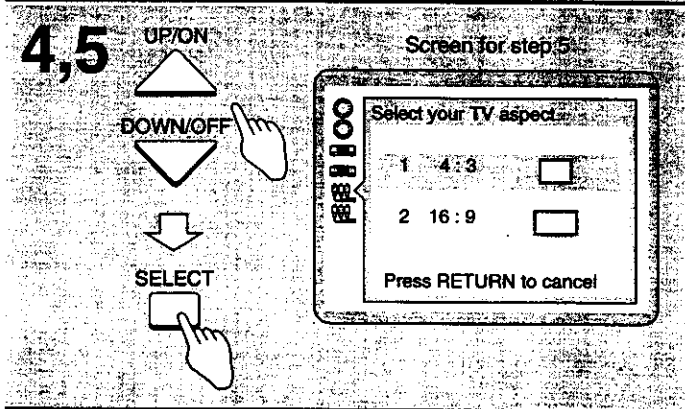
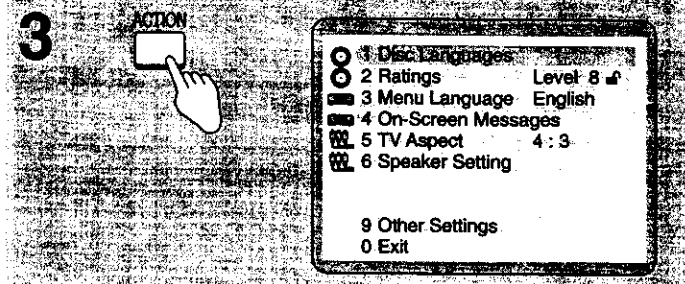
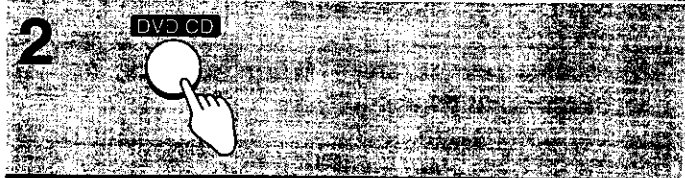
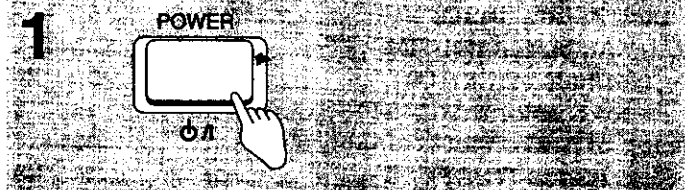

Playing discs

DVD **CD**

Preparation

- Turn the television on.
- Switch the video input mode on the television to suit the type of connection you have made (e.g., VIDEO 1).

1 Press [SELECTOR] to select "DVD/CD" as the source.

The source changes each time you press the button on the main unit.

DVD/CD → FM → AM → TV → VCR → AUX

Remote control: Press [DVD/CD].
The unit comes on automatically.

2 Press [DISC 1] to [DISC 5] to select a tray.

The indicator lights.

Play starts if a disc is in the tray. (One-touch play)
"NO DISC" is displayed if there is no disc in the tray.

Remote control:

Press [DISC] and then the numbered button corresponding to the required tray.

3 Press [▲ OPEN/CLOSE] to open the tray and insert a disc.

Press again to close and start play. Use this button to open the tray when removing discs.

(Continued on next page)

Preparations, Disc operations

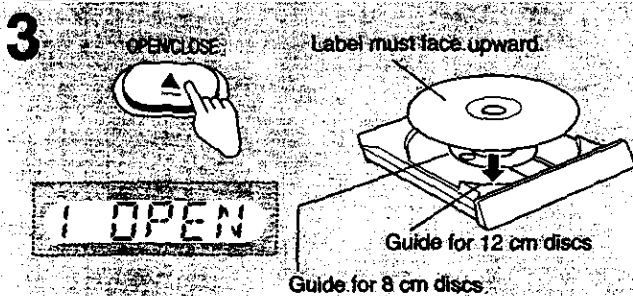
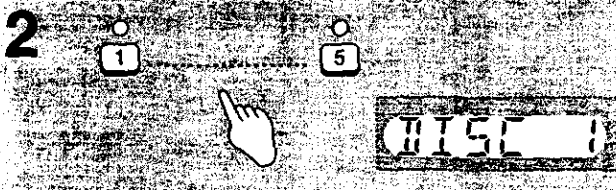
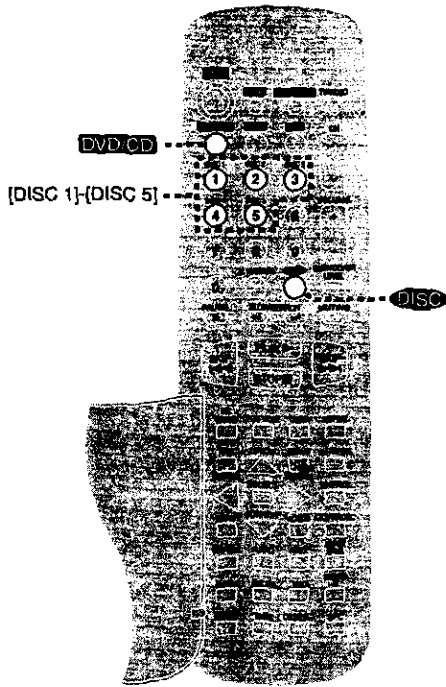
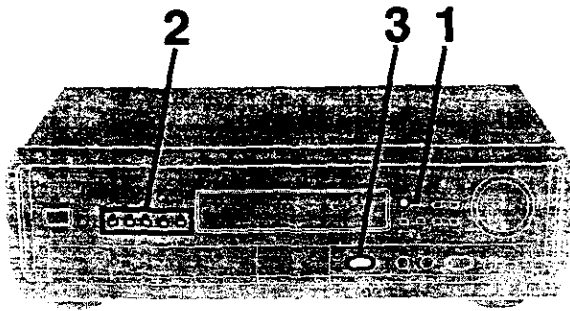

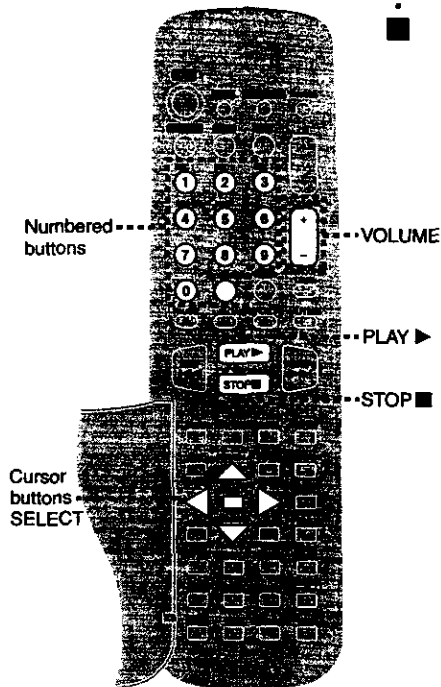
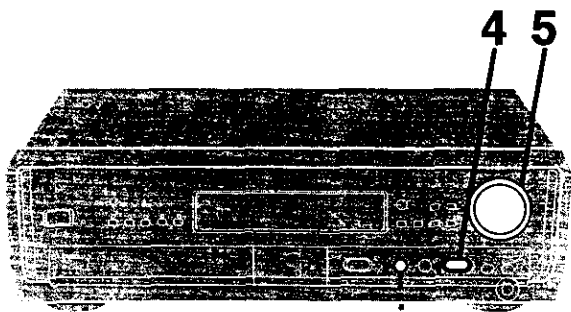

4

If play doesn't start after step 3.

Press [▶] to start play.

Remote control: Press [PLAY ▶].

If a title menu appears on the television.

- Use the cursor buttons to highlight a title and press [SELECT] on the remote control.
- Use the numbered buttons to select a title.
For channels 10 or over
To select channel 10: [≥10/ENTER] → [1] → [0]
To select channel 11: [≥10/ENTER] → [1] → [1]

Note

Menu items on video CD with playback control (PBC) can only be selected with the numbered buttons.

5

Adjust the volume.

Remote control: Press [VOLUME (+ or -)].

To stop the discs

Press [■].

Remote control: Press [STOP ■].

Resume function (⇒ page 17)

“⊘” appears on the TV when you press a button

This means the operation is not allowed at that time.

4

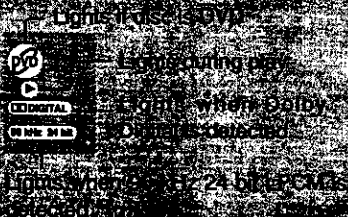

5

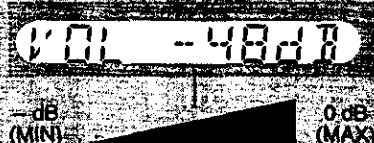
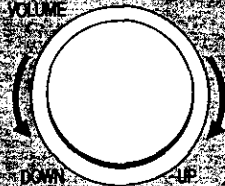

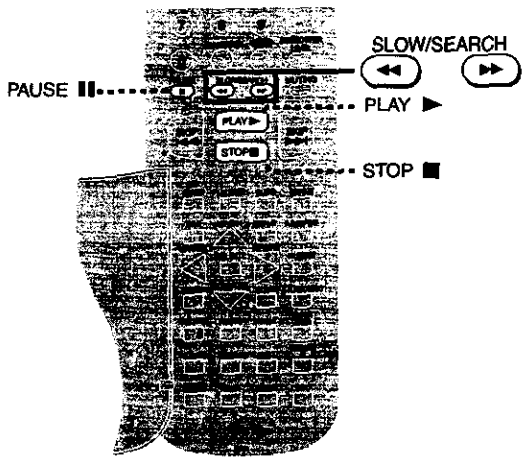
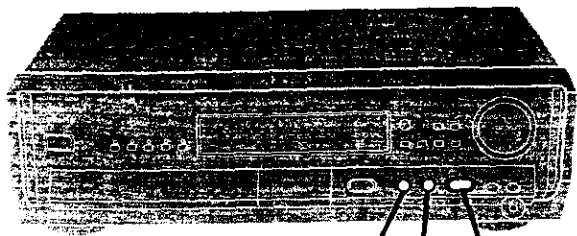

A

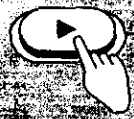

B



C



D

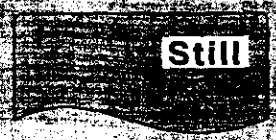

E



Other methods of play

DVD CD

Using the resume function to restart play

If you press [■] or [STOP ■] during play, the unit remembers the position.

A To restart play from that point
 Press [▶] while "RESUME" is lit.
 Remote control: Press [PLAY ▶]

B To review the chapters up to the point where you stopped play (DVD only)
 The message shown in the illustration appears for a few seconds before the resume function is activated after pressing [▶].

Press [▶] while this message is on the screen and the beginning portions of each chapter up to the current one are played.

Remote control: Press [PLAY ▶]
 Full play resumes from the point where you stopped play.

C To cancel the resume function
 Press [■] while "RESUME" is lit.
 Remote control: Press [STOP ■]

Note

- Resume is cancelled if the disc tray is opened or if you change discs.
- Resume does not work if the disc's play time is not displayed.
- The position is saved even if the unit is turned off.
- Chapter preview is not possible with some DVDs.
- Chapter preview may not be activated if you were watching chapter 1.

D Pause (Still picture)

Press [⏸] during play.
 Remote control: Press [PAUSE ⏸]

To resume play
 Press [▶] or [PLAY ▶].

E Search function Remote control only

Press [SLOW/SEARCH (◀◀ or ▶▶)] during play.

- ◀◀ : backwards
 - ▶▶ : forwards
- Each press increases the speed of the search. There are five speeds.

To resume play
 Press [▶] or [PLAY ▶].

For your reference

- Sound will be heard at speed one when searching forwards during DVD player.
 You can turn this sound off if required.
 (⇒ "Audio during Search", page 44)
- Sound will be heard at all speeds when playing audio CD.
- If pressed while playing a video CD with PBC, you may return to a menu screen.

Disc operations

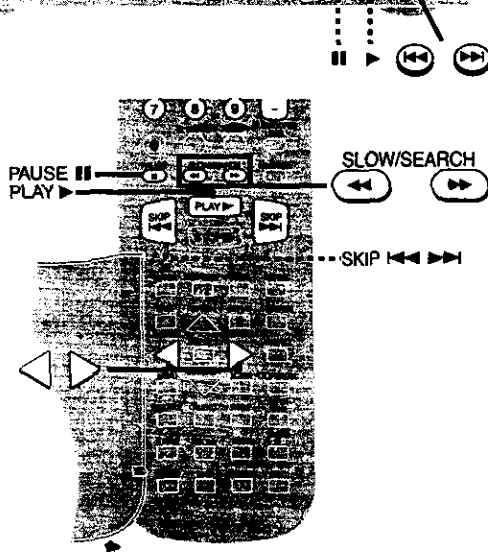
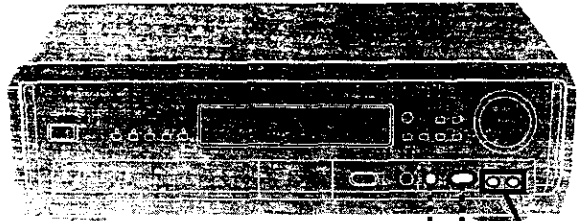

A Skip function

DVD **CD**

Press [**⏮**] or [**⏭**] to skip tracks on CD and Video CD, and chapters on DVD video.

Remote control: Press [SKIP **⏮**] or [SKIP **⏭**].

- ⏮** : backwards
- ⏭** : forwards

- Each press increases the number of skips.
- The first skip backwards takes you to the beginning of the current track (⇒ page 50) or chapter (⇒ page 50).

Note

If pressed while a video CD menu is on the screen, you may return to the previous menu.

B Frame-by-frame viewing

Remote control only

DVD

While paused

Press the cursor buttons [**◀**] or [**▶**].

- ◀** : Backward
- ▶** : Forward

- The frame changes each time you press a button.
- The frames change in succession if you press and hold the button.
- The frames also advance if you press [**⏸**] on the main unit or [PAUSE **⏸**] on the remote control.

To resume play

Press [**▶**] or [PLAY **▶**].

Note

You cannot move backwards with video CD.

C Slow-motion play Remote control only

DVD

While paused

Press [SLOW/SEARCH **⏮** or **⏭**].

- ⏮** : Backward
- ⏭** : Forward

Each press increases the speed of the slow motion. There are five speeds.

To resume play

Press [**▶**] or [PLAY **▶**].

Note

You cannot move backwards with video CD.

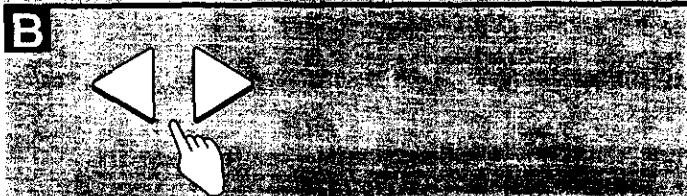
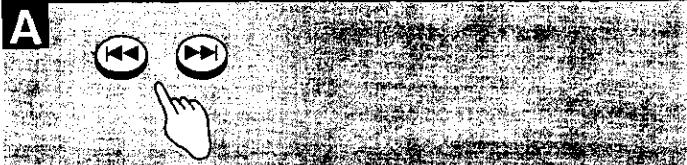

Repeat function Remote control only

DVD CD

A Repeating chapters, titles, and tracks

Press [REPEAT] during play.

Each time you press the button.

• DVD

- Ⓐ CHAPTER REPEAT: Chapter repeated.
- Ⓑ TITLE REPEAT: Titles repeated.
- Ⓒ REPEAT OFF: Repeat mode canceled.

• Video CD/Audio CD

- Ⓓ TRACK REPEAT: Tracks repeated.
- Ⓔ ALL REPEAT: Repeat of entire disc contents.
- Ⓕ REPEAT OFF: Repeat mode canceled.

To cancel repeat play

Press [REPEAT] until "OFF" appears on the TV or "OFF" disappears from the unit's display.

Note

Repeat play does not work with some DVDs. It also doesn't work with interactive DVDs and video CDs with playback control.

B Repeating a specific section (A-B REPEAT)

1 Press [A-B REPEAT] during play at the starting point (A).

2 Press [A-B REPEAT] at the finishing point (B).

To cancel A-B repeat play

Press [A-B REPEAT] until "A-B" is displayed.

Note

- This feature cannot be used if the play time for the DVD is not displayed.
- The player automatically determines the end of a title or track as Point B.
- Subtitles may not appear between A and B.

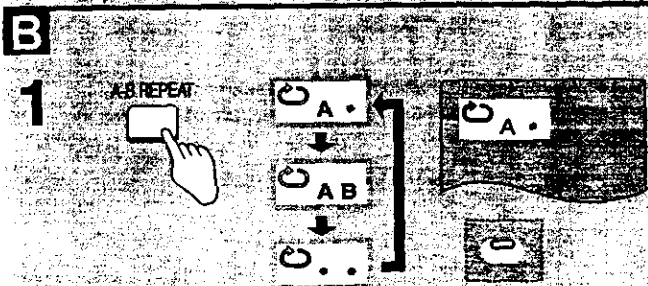
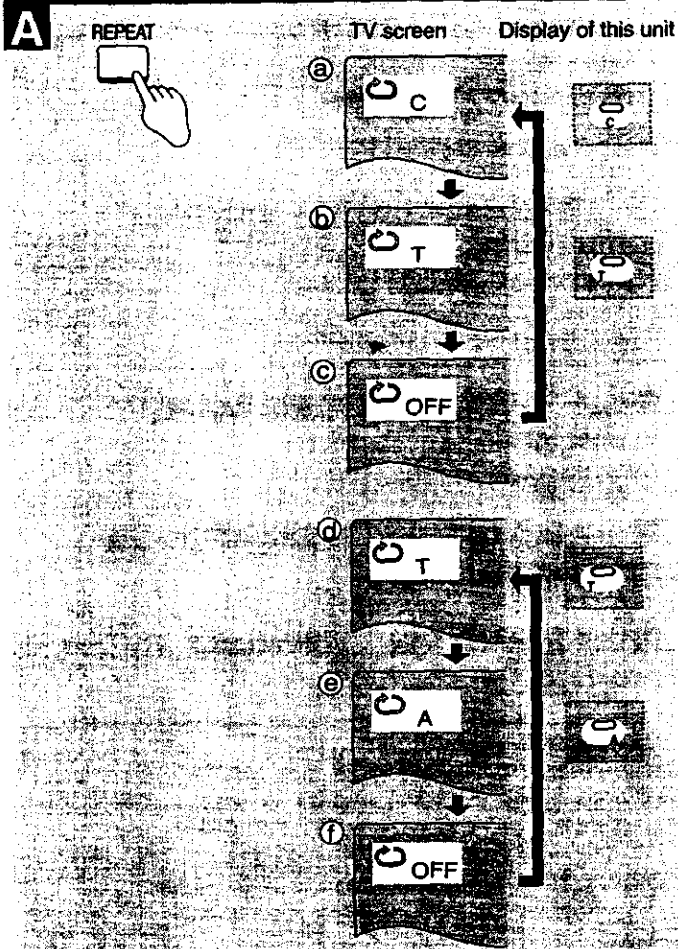
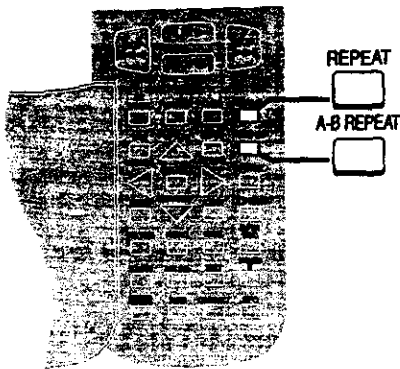

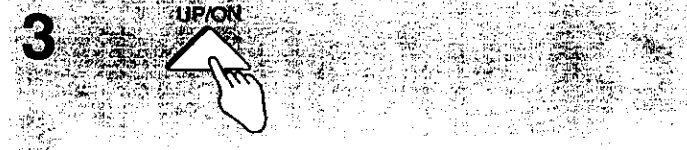
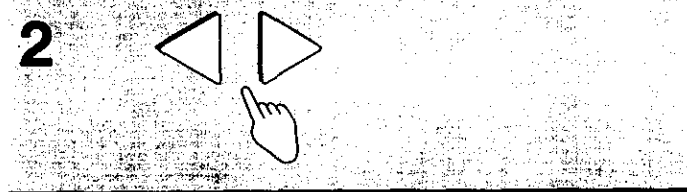
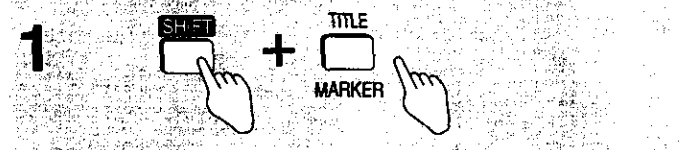
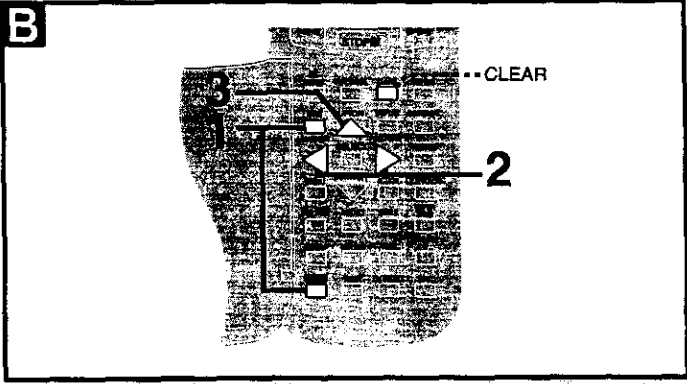
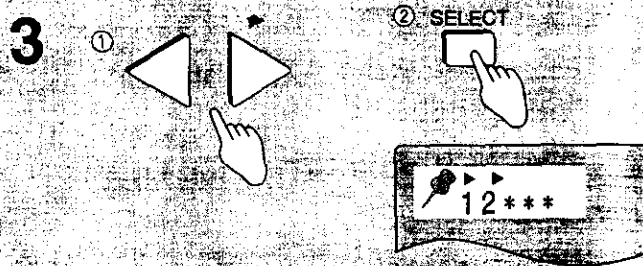
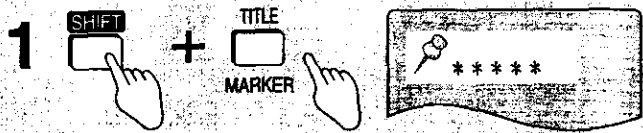
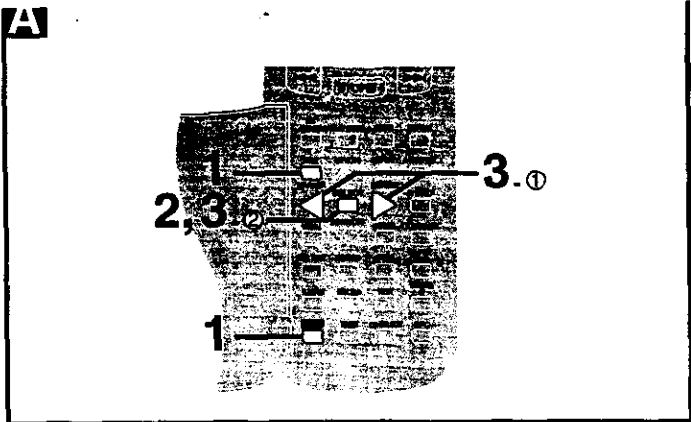

A Marking a position Remote control only



This feature allows you to mark a specific point on a disc so you can return to it easily at a later time. There are five markers available. It only works if the elapsed playing time of the disc you are playing is shown on the unit's display.

- 1 Press [SHIFT]+[TITLE, MARKER] during play.**
The marker display appears.
- 2 Press [SELECT] at the point you want to mark.**
Up to five markers can be stored.

To mark another position

- 3**
 - ① Press [◀] or [▶] to change markers.
 - ② Press [SELECT].

B Recalling a marked position

- 1 Press [SHIFT]+[TITLE, MARKER] during play.**
The marker display appears.
- 2 Press [◀] or [▶] to highlight the required marker.**
- 3 Press [UP/ON ▲] to recall the position.**

To clear a marker

- ① Press [SHIFT]+[TITLE, MARKER].
- ② Press [◀] or [▶] to highlight the marker you want to clear and press [CLEAR].

Press [SHIFT]+[TITLE, MARKER] to clear the marker display.

Note

- This feature can not be used with some DVDs or with video CDs with PBC. (→ page 50)
- Some subtitles may fail to appear around the marker (DVD).
- Markers are cleared when the unit is turned off or the disc is removed or changed.

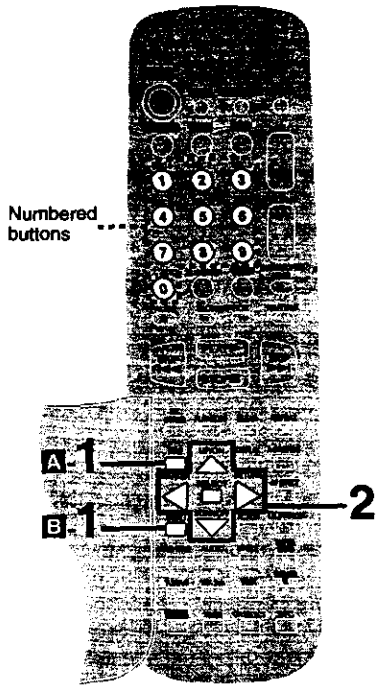

A Title menu Remote control only

DVD

The title menu is used if there are different titles included on the one DVD.

- 1 While stopped or playing
Press [TITLE, MARKER] to display the title menu.
- 2 Use the cursor buttons to highlight a title, and press [SELECT].

For your reference

You can select items with the numbered buttons with some discs.

B DVD menu Remote control only

DVD

Many DVDs have a variety of material recorded on them, apart from the main feature. Other DVDs require you to use menus to enjoy them. The actual operation of the menus depends on the disc, so here we will explain only the basic steps.

- 1 While stopped or playing
Press [MENU] to display the menu.
- 2 Press the cursor buttons to highlight an item, and press [SELECT].

For your reference

You can select items with the numbered buttons with some discs.

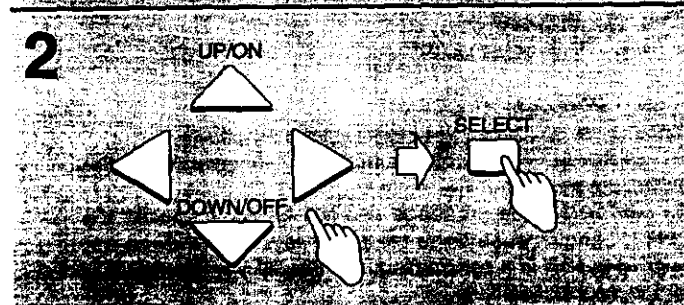
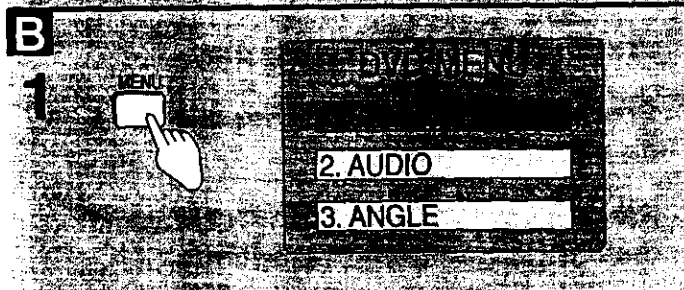
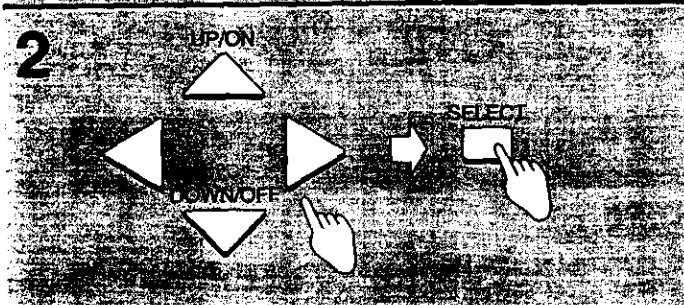
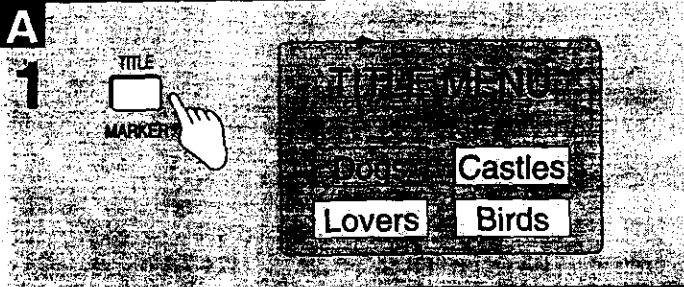

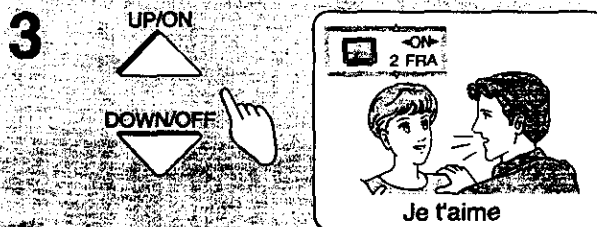
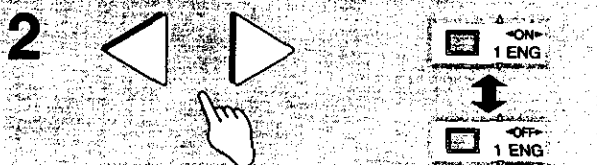
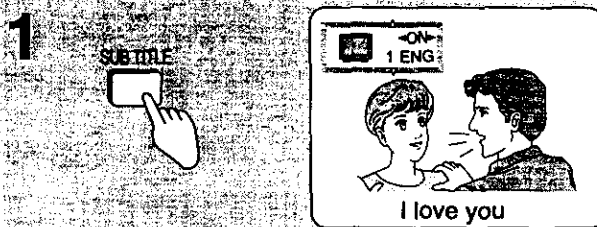
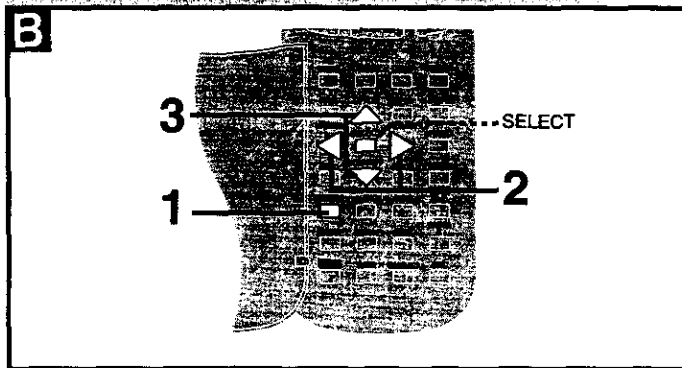
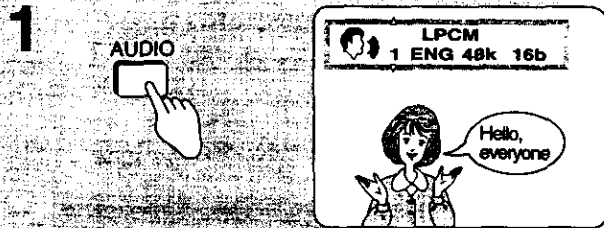
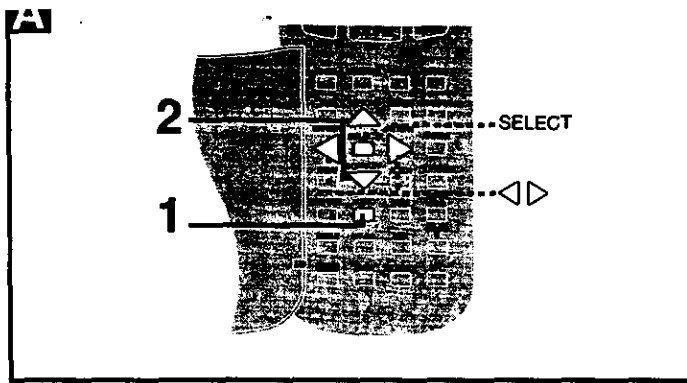

Other methods of play

A Changing soundtracks

Remote control only

DVD

Some DVDs have more than one soundtrack recorded on them, such as multiple languages or PCM, and you can change soundtracks during play.

- 1 Press [AUDIO] during play.
- 2 Press [UP/ON \triangle] or [DOWN/OFF ∇] to change the soundtrack.

To clear the display

Press [AUDIO] or [SELECT].

Note

- You can only select languages or sound formats if they have been recorded on the disc you are playing.
- You can also make permanent language settings before play with the Audio Language settings (⇒ page 44). (Some discs are designed to start in a certain language despite any changes you make to the initial settings.)

Using this feature with karaoke discs

You can do the following with karaoke discs.

While playing a karaoke disc

Press [\triangleleft] or [\triangleright] to change the vocals.

DVD karaoke disc (Solo)	DVD karaoke disc (Duet)
[--]: Vocal OFF	[--]: Vocal OFF
[ON]: Vocal ON	[1+2]: Vocal 1, 2 ON
	[V1]: Vocal 1 only ON
	[V2]: Vocal 2 only ON

Press [UP/ON \triangle] or [DOWN/OFF ∇] to change the vocals.

Multi-audio disc (Video CD)

[LR]: Left and right channel sound from each speaker
[L]: Only left channel sound
[R]: Only right channel sound

B Changing subtitle language

Remote control only

DVD

Some DVDs have more than one subtitle language recorded on them, and you can change language during play.

- 1 Press [SUB TITLE] during play.
- 2 Press [\triangleleft] or [\triangleright] to turn the subtitles on and off.
- 3 Press [UP/ON \triangle] or [DOWN/OFF ∇] to change the subtitle language.

To clear the display

Press [SUB TITLE] or [SELECT].

For your reference

- There may be a slight delay before subtitles are shown.
- You can only select languages if they have been recorded on the disc you are playing.
- You can also make language settings before play with the Subtitle Language settings (⇒ page 44). (Some discs are designed to start in a certain language despite any changes you make to the initial settings.)

Other methods of play

A Switching angles Remote control only

DVD

Some DVDs allow you to view the same scene from different angles.

- 1 Press [ANGLE] during play.
- 2 Press [UP/ON \triangle] or [DOWN/OFF ∇] to change the angle.

To clear the display
Press [ANGLE] or [SELECT].

Note

- "ANGLE" lights up on the unit's display during scenes with multiple angles recorded to indicate this feature is available.
- Some discs allow you to set angles before multi-angle scenes are played. Read the instructions that come with the DVD.

B Starting play from a specific track

Remote control only

CD

- 1 Press [DISC].
- 2 Press [1]–[5] to select a disc.
- 3 Wait for the disc to change and play to start, Press the numbered buttons to select the track.

For tracks numbered 10 or over, press [≥ 10 /ENTER] then the two digits.

- Track no. 10: [≥ 10 /ENTER] → [1] → [0]
- Track no. 25: [≥ 10 /ENTER] → [2] → [5]

Note

- When playing video CDs with PBC, stop the disc then press [STOP \blacksquare] again to cancel playback control, then select the track number. To restore playback control, stop the disc and press [MENU].
- There are some video CDs with PBC where this will not work.

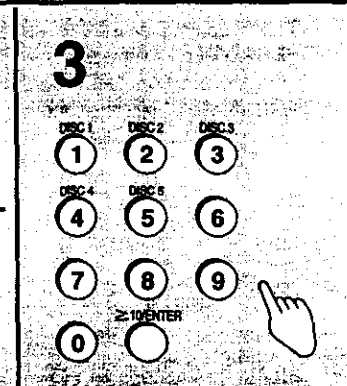
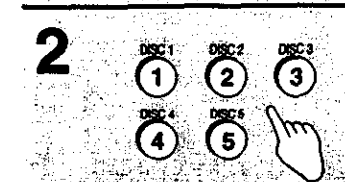
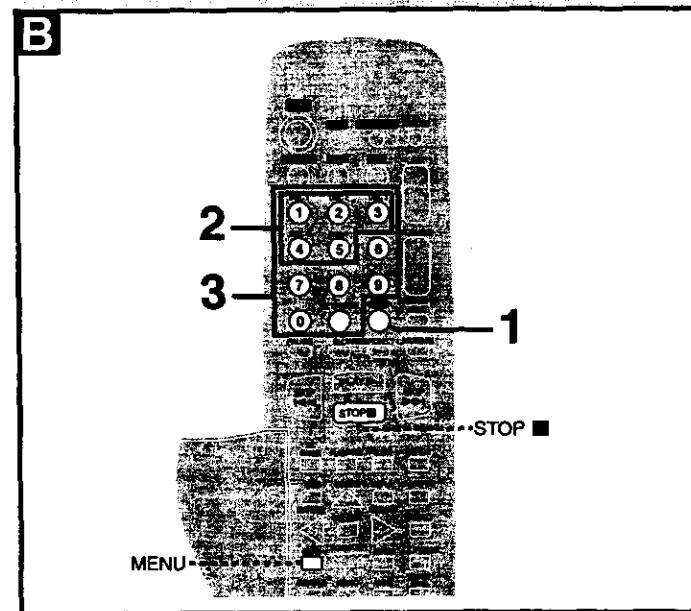
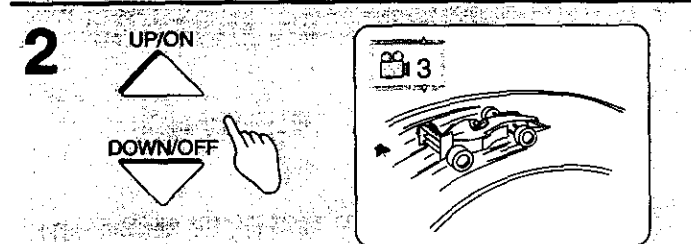
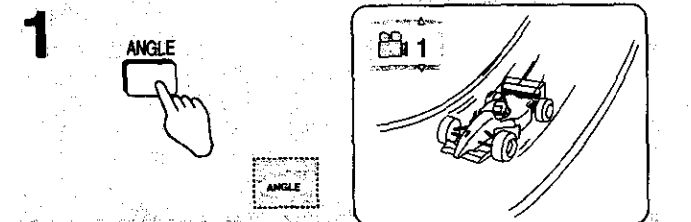
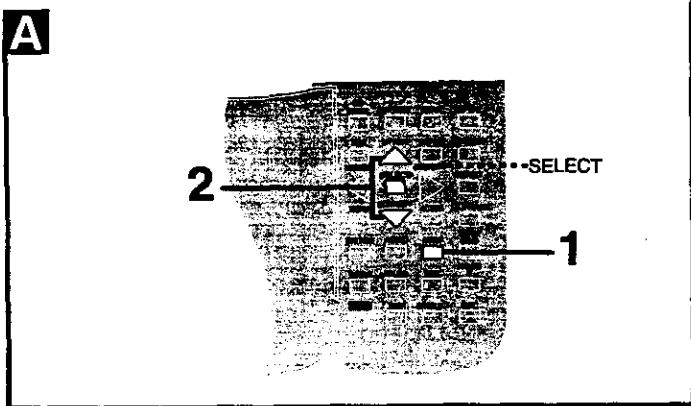

Disc operations

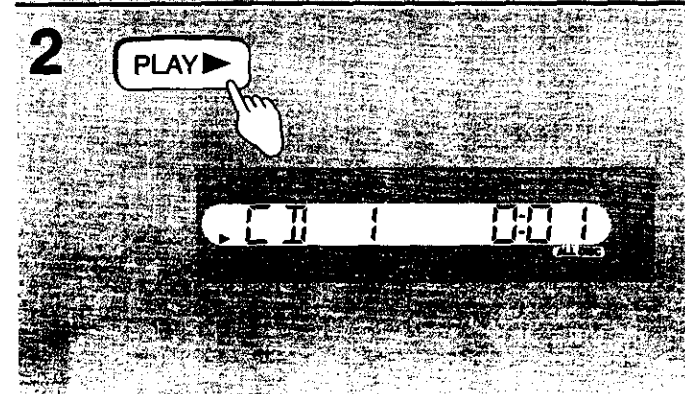
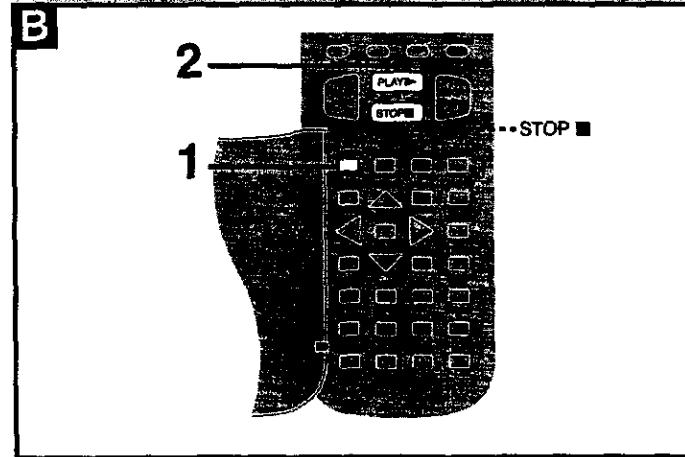
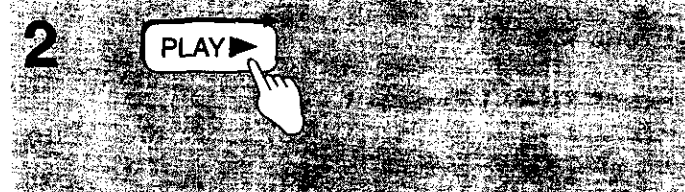
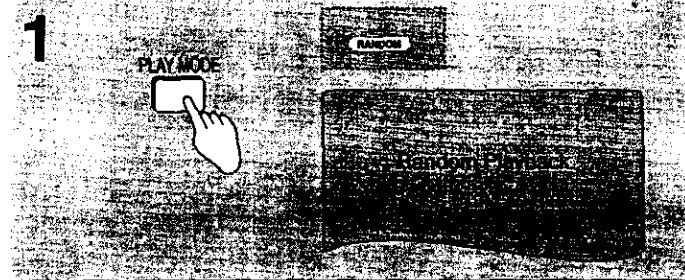
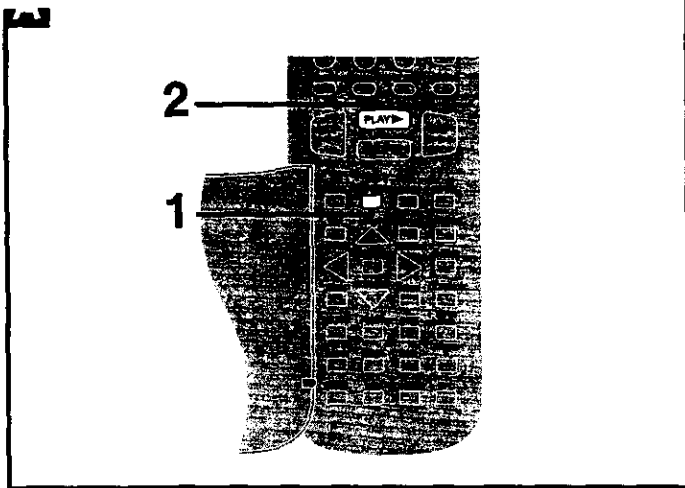

A Random play Remote control only



This mode plays the tracks once each in random order.

1 While stopped
Press [PLAY MODE] to select "RANDOM".

Each time the button is pressed,
PRGM → RANDOM
←(off)←

2 Press [PLAY ▶].

To cancel random play

After stopping play
Press [PLAY MODE] to select "off".

B Using the Disc Manager Remote control only



You can play up to five discs in succession or repeatedly.

1 While stopped
Press [DISC MANAGER] to select the desired method.

Every time you press the button;

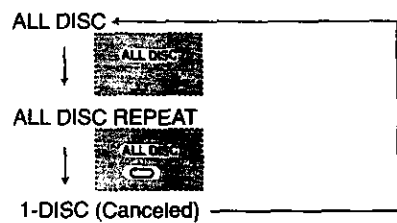

- ALL DISC: Up to five discs are played in succession.
- ALL DISC REPEAT: Up to five discs are played repeatedly.
- 1-DISC: The disc in the play position is played.

2 Press [PLAY ▶].

The disc manager is also canceled if [STOP ■] is pressed while stopped.

Note

- The disc manager mode cannot be changed while "RESUME" is on.
- The disc manager can only be used with audio CDs. The function is canceled if play is started with a DVD or video CD in the play position. DVDs and video CDs are skipped if they are encountered while the function is active.

Program play Remote control only



You can select up to 18 tracks to play in the order you choose.

1 While stopped
Press [PLAY MODE] to select "PRGM".

Each time the button is pressed,
PRGM → RANDOM
 ↑
 (off)

2 Use the cursor buttons to highlight the track, and press [SELECT].

You can also use the numbered buttons to select tracks.
For tracks numbered 10 or over, press [≥10/ENTER] then the two digits.

Track no. 10: [≥10/ENTER] → [1] → [0]
Track no. 25: [≥10/ENTER] → [2] → [5]

Repeat step 2 to program the tracks in the required order.

3 Press [PLAY ▶].

To cancel program play

After stopping play
Press [PLAY MODE] to cancel the mode.

• **To clear the last track**

Use the cursor buttons to highlight "Clear last" and press [SELECT]. You can also press [CLEAR].

• **To clear the whole program**

Use the cursor buttons to highlight "Clear all" and press [SELECT].

Numbered buttons

3

1

2

---CLEAR

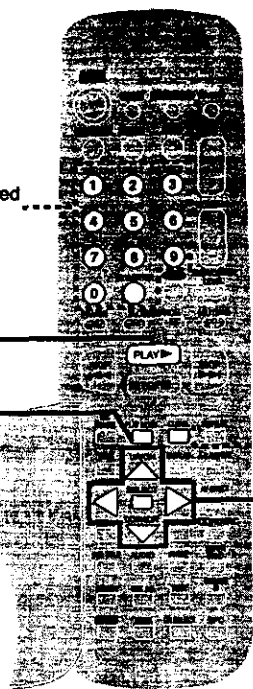

1

PLAY MODE

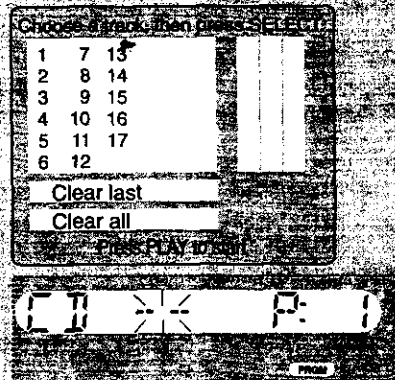

2

UP/ON

DOWN/OFF

SELECT

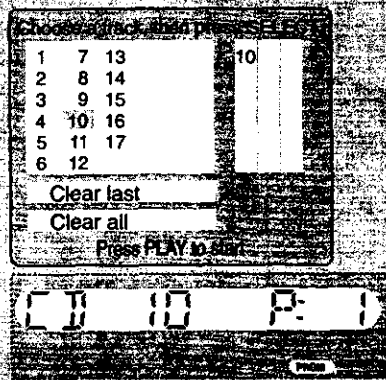
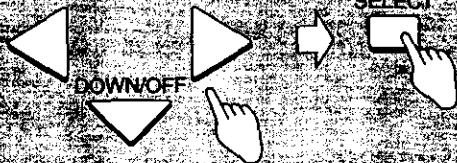

3

PLAY ▶



Remote control only

DVD  CD 

GUI (Graphical user interface) are icons that appear on the screen that allow you to interact with the player. The long thin GUI that show information about the unit and discs are called GUI screens. You can perform various operations by changing the information shown in these screens.

1 Press [DISPLAY, RETURN].

The GUI screen appears.

The screen changes each time you press the button.

2 Press [◀] or [▶] to select an item.

3 Press [UP/ON ▲] or [DOWN/OFF ▼].

To clear the GUI screen

Press [DISPLAY, RETURN] until the original screen is restored, or press [CLEAR].

For your reference

- Some items require different operations to change the contents, so refer to the GUI icon descriptions (⇒ page 28, 29) for details.
- The GUI screens clear after performing some operations, such as changing the title, track or chapter.
- If the GUI screen is partially cut off or fails to appear, go to the initial settings menu to change the position of on-screen messages (⇒ page 44).

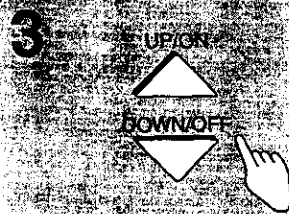
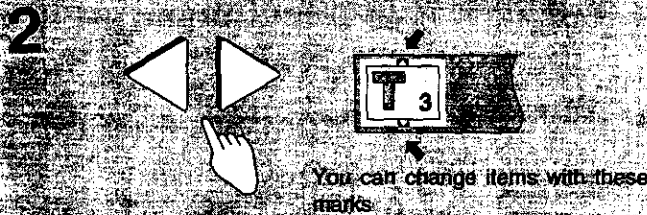
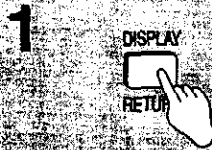
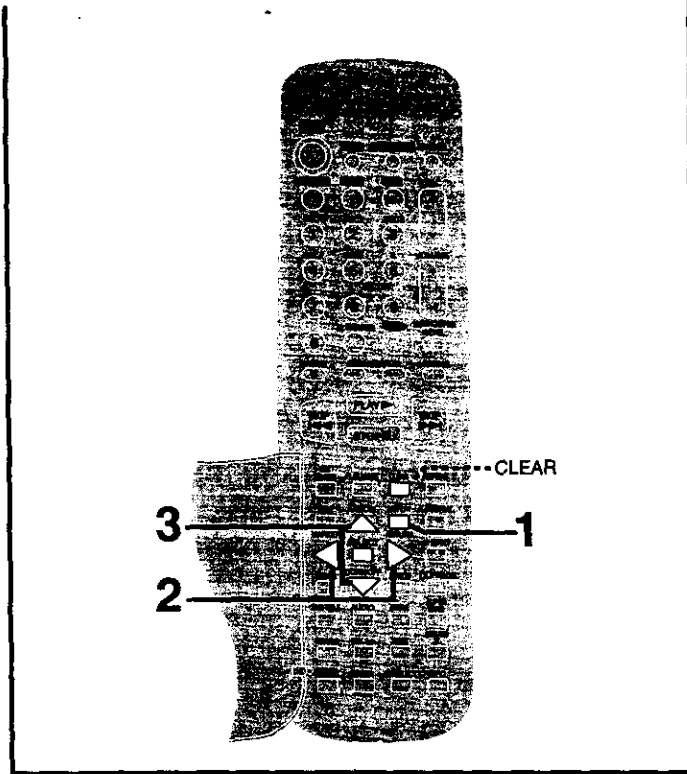

GUI screens

There are three different GUI screens and the contents of each screen depend on the kind of disc being played.

Disc GUI screen: You can change the title, track, or chapter, and switch the time display, soundtrack, subtitles, and angles.

Unit GUI screen: You can start repeat play or mark parts you want to play again.

Shuttle GUI screen: You can fast forward, rewind, or start slow motion play.

DVD

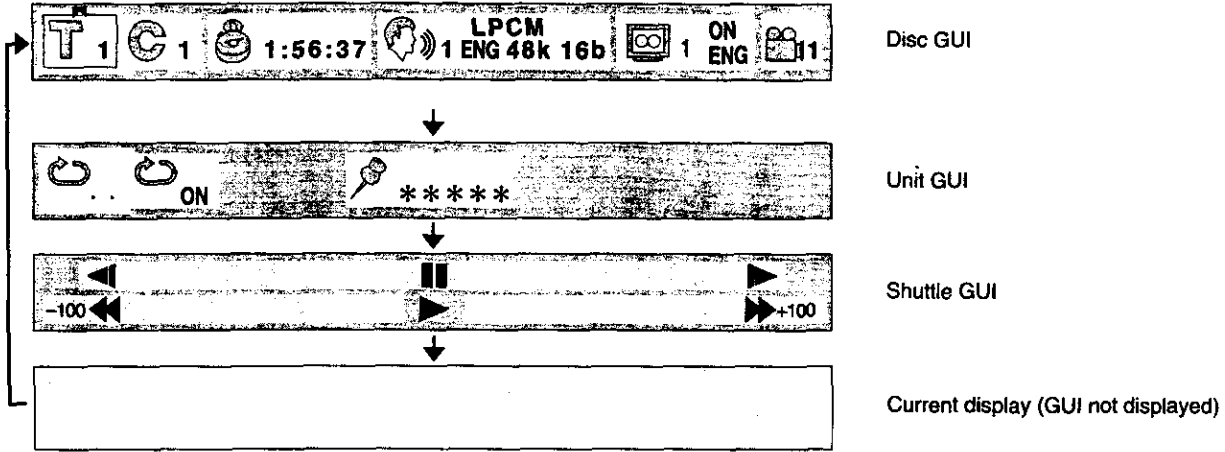



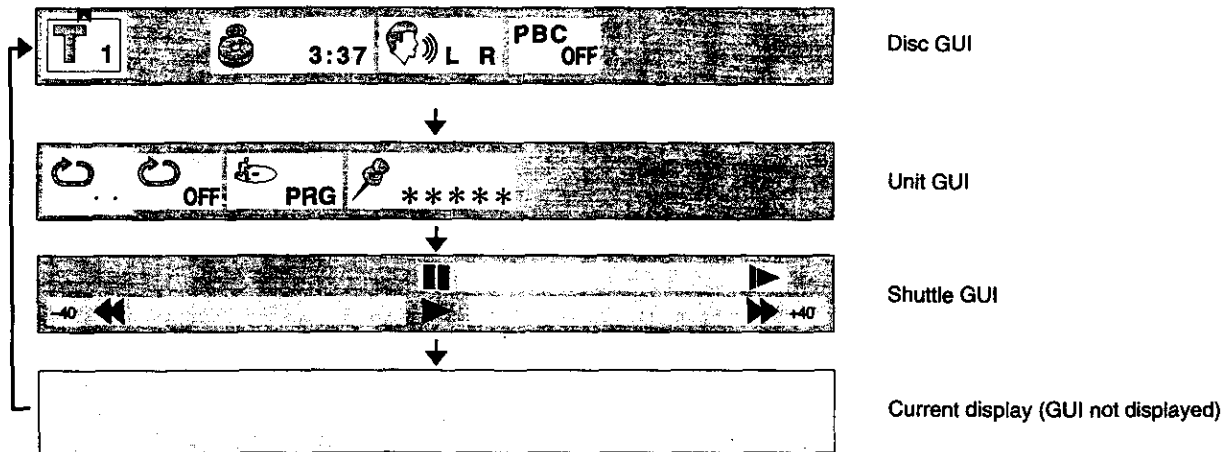



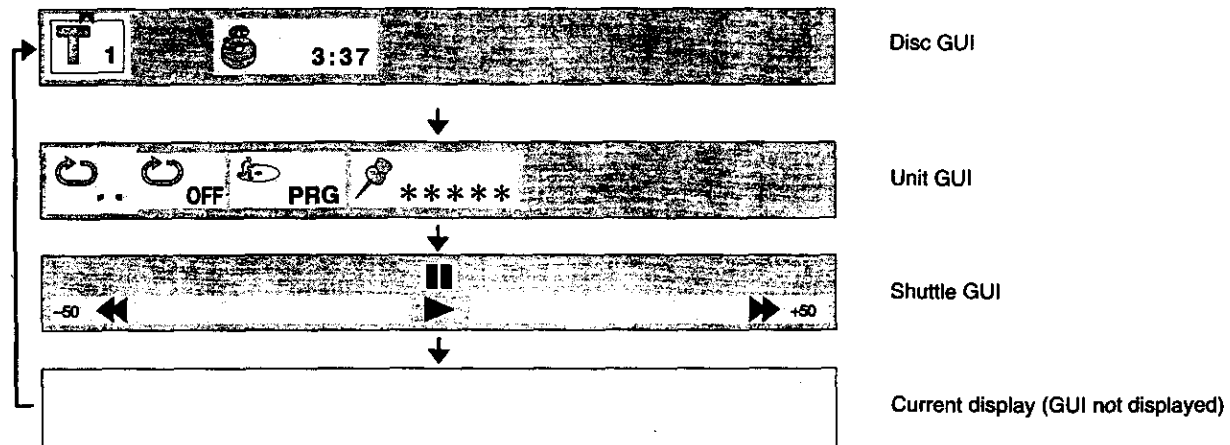

Video CD

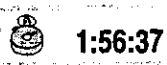
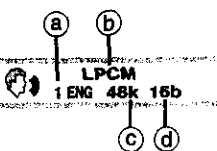

Audio CD

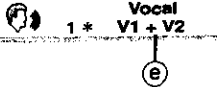

GUI icon descriptions

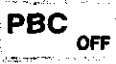
Disc GUI		
Icon	Content	Operation
	Title number (DVD) or track number (video CD, CD)	Press [△] or [▽] or the numbered buttons to change the number and press [SELECT]
	Chapter number (DVD)	DVD only Press [△] or [▽] or the numbered buttons to change the number and press [SELECT]
	Time (select a position to start play by specifying a time)	DVD only Press the numbered buttons and press [SELECT]
	Press to change the time information displayed Elapsed time of current track ↔ Remaining time of current track ↔ Remaining time on disc	Video CD/Audio CD Press [△] or [▽]
	a) Soundtrack number See the bottom of page 29 for a key to language abbreviations.	DVD only Press [△] or [▽] or the numbered buttons to change the number and press [SELECT]
	b) Type of audio signal • LPCM (linear PCM),  (Dolby Digital) or DTS c) Sampling rate or number of channels • LPCM: 48 kHz or 96 kHz •  Dolby Digital: 1 to 5.1 channels • DTS: 1 to 5.1 channels d) Number of bits • LPCM: 16 or 24 bits	DVD only —
	e) Vocals on or off Solo karaoke disc: --- or ON Duet karaoke disc: ---, V1 + V2, V1, or V2	DVD karaoke only Press [△] or [▽]
	f) Subtitle number See the bottom of page 29 for a key to language abbreviations.	DVD only Press [△] or [▽] or the numbered buttons to change the number
	g) Subtitles on or off	DVD only Press [△] or [▽]
	Angle number	DVD only Press [△] or [▽] or the numbered buttons to change the number
	Audio mode L: Left channel sound R: Right channel sound LR: Left and right channels signals	VCD only Press [△] or [▽]
	Indicates whether menu play (PBC) is on or off	VCD only —

* Some discs will not allow some of these operations.

Unit GUI screen

Icon	Content	Operation
	Start and finish points for A-B repeat.	Press [SELECT] at the start point and again at the finish point.
	Select a repeat play mode DVD: C (chapter) T (title) Video CD/Audio CD: T (track) A (disc)	Press [△] or [▽]
	Shows the current play mode ---: normal PRG: Program RND: Random	Video CD/Audio CD only —
	Mark a position	Press [SELECT]
	Recall a mark	Press [◀] or [▶] to select the mark and press [△] to recall the position
	Erase a mark	Press [◀] or [▶] to select the mark and press [CLEAR]

Shuttle GUI

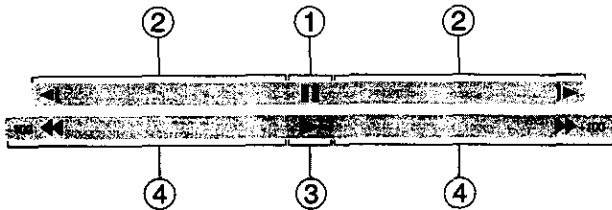

Five levels of speed can be selected in either direction.

Content	Operation
① Pause	Press [△]
② Slow-motion play ◀: reverse (DVD only) ▶: forward (DVD, Video CD only)	Press [△] to pause and press [◀] or [▶]
③ Play	—
④ Fast forward and rewind ◀◀: rewind ▶▶: fast forward The numbers indicating speed depend on the type of disc DVD: +100 to -100 Video CD: +40 to -40 Audio CD: +50 to -50	Press [▽] then press [◀] or [▶]

Language abbreviations

ENG	English	POR	Portuguese	FRA	French	RUS	Russian	DEU	German	JPN	Japanese
ITA	Italian	CHI	Chinese	ESP	Spanish	KOR	Korean	NLD	Dutch	MAL	Malay
SVE	Swedish	VIE	Vietnamese	NOR	Norwegian	THA	Thai	DAN	Danish	*	Others

Disc operations

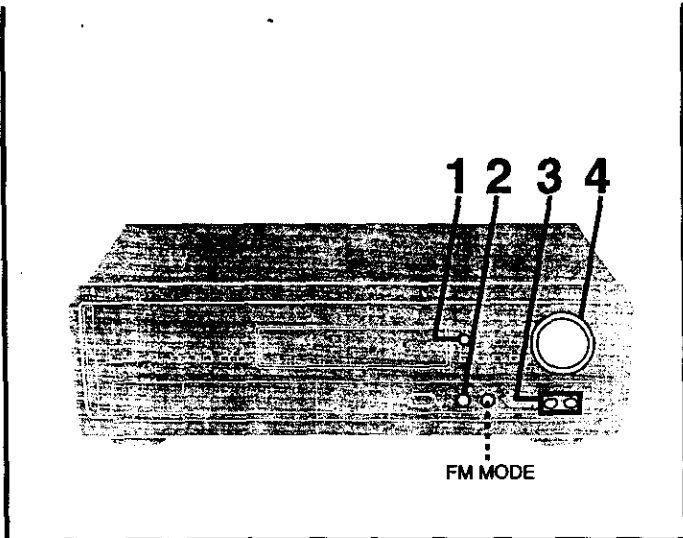

1 Press [SELECTOR] to select "FM" or "AM".

Each time the button is pressed,
 DVD/CD → FM → AM → TV → VCR → AUX

2 Press [TUNE MODE] to select "MANUAL".

Each time the button is pressed; "MANUAL" ↔ "PRESET".

3 Press [TUNING (∨ or ^)] to select the frequency of the required station.

"TUNED" is displayed when a radio station is tuned.
 "STEREO" is displayed when a stereo FM broadcast is being received.

4 Adjust the volume.

Auto tuning

Press and hold [TUNING (∨ or ^)] for a moment until the frequency starts changing rapidly. The unit begins auto tuning, stopping when it finds a station.

Note

Tuning may stop before a station is found if interference is encountered.

If noise is excessive in FM

Press [FM MODE] to display "MONO".

- This mode improves sound quality if reception is weak for some reason, but broadcasts are heard in monaural.
- Turn "MONO" off for normal listening.

FM frequency step

The step is set to 0.2 MHz at the factory. It can be changed to enable the tuner to receive stations broadcast in 0.1 MHz steps.

Any FM frequencies that have been preset will be changed by this procedure. Be sure to carry out presetting again.

Press [SELECTOR] to select "FM". Now press and hold [SELECTOR]. After 5 seconds the display changes to show the current lowest FM frequency. Continue to hold down the button. After about ten seconds, the minimum frequency changes and the step is changed at the same time.

Repeat this procedure to change the step back.

Note

AM reception is monaural.

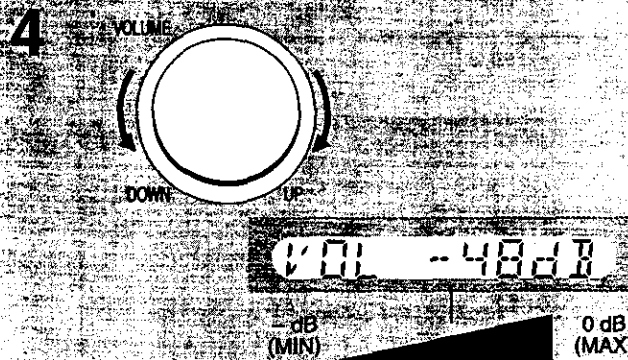
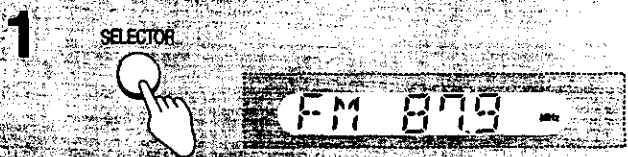

The radio preset tuning

- Tuning is simpler if you preset stations.
 - You can preset 12 FM and 12 AM stations.
- Choose either automatic tuning, which presets all the stations the tuner can receive, or manual presetting, which allows you to select the stations to preset and the order they are to be preset in.

A Automatic presetting

Do the following once each for FM and AM.
Preparation: Tune to the frequency where presetting is to begin (→ page 30).

Hold down [MEMORY].

Release the button when the frequency begins to change.
 The stations are preset into the channels in ascending order.
 The last station to be preset is played when presetting is complete.

Manual presetting

Preset the stations one at a time.

- ① Press [MEMORY].
- ② Tune to the required frequency.
- ③ Press [MEMORY].
- ④ Press [TUNING (∨ or ∧)] to select a channel.
- ⑤ Press [MEMORY].

The station occupying a channel is erased if another station is preset in that channel.

B Selecting channels

- 1 Press [SELECTOR] to select "FM" or "AM".

- 2 Press [TUNE MODE] to select "PRESET".
 Each time the button is pressed; "MANUAL" ↔ "PRESET".

- 3 Press [TUNING (∨ or ∧)] to select preset channel.

• On the remote control

- ① Press [TUNER/BAND] to select "FM" or "AM".
- ② Press the numbered buttons to select the channel.
 For channels 10, 11, and 12, press [≧10/ENTER] then the two digits.
 10 ch: [≧10/ENTER] → [1] → [0]
 11 ch: [≧10/ENTER] → [1] → [1]
 Or
 Press [CH (∨ or ∧)] to select a channel.

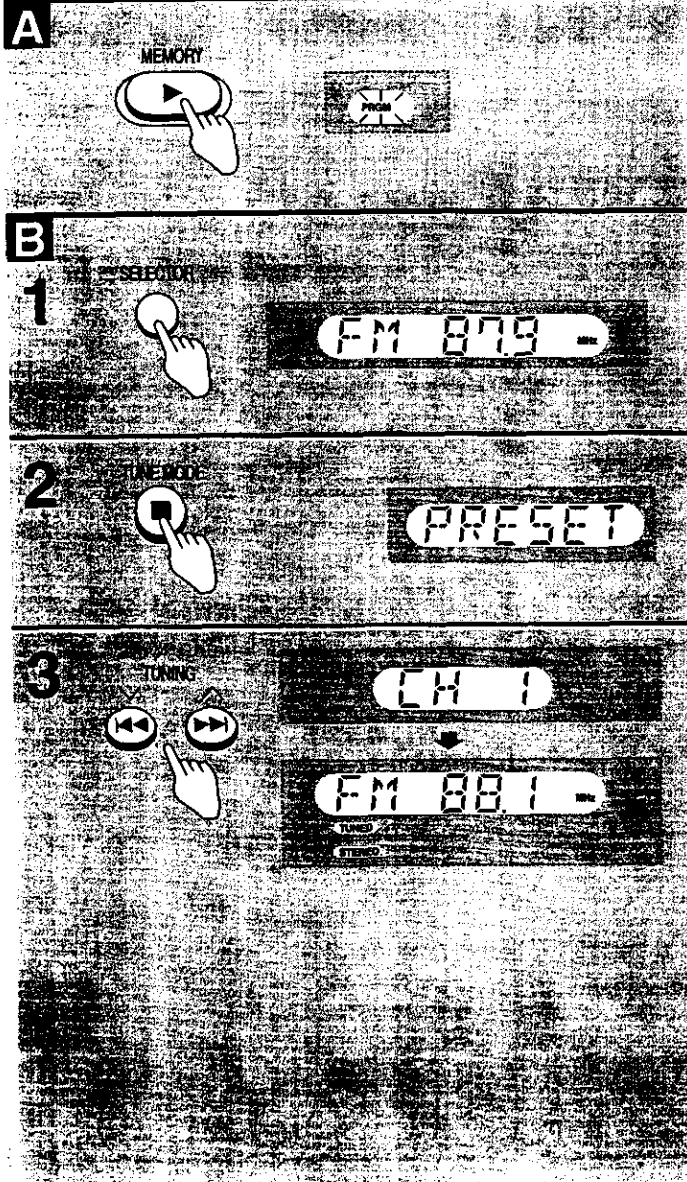
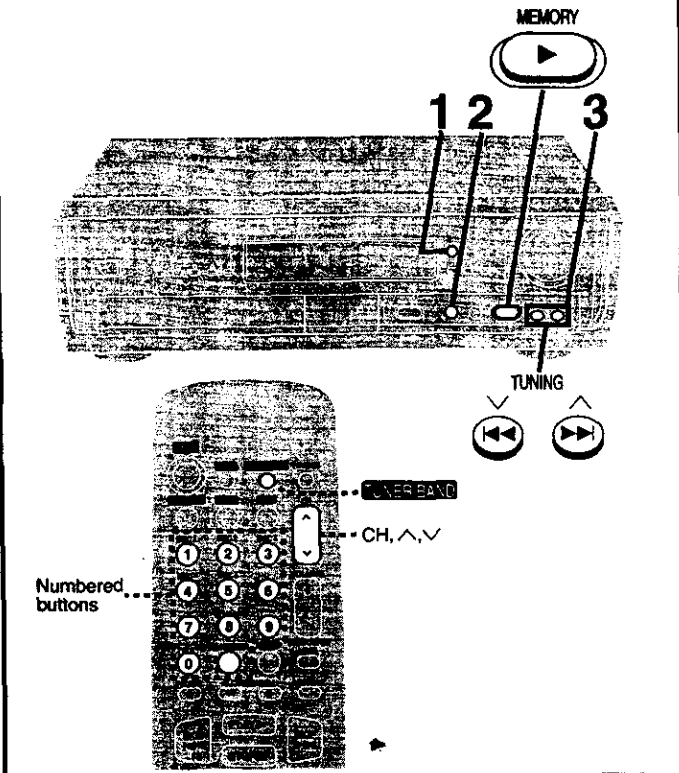

Sound field effects you can enjoy with this unit

Sound field system

Features

Software

Dolby Digital

Dolby Digital is a discrete 5.1 channel surround system developed for cinema use.

This unit automatically recognizes DVDs that have been recorded with Dolby Digital.

Not all Dolby Digital sources are recorded with 6 channels. Some sources marked Dolby Digital may be recorded in Dolby Surround, a 2 channel system.



Software encoded with Dolby Digital can be identified with this mark.

- DVD

Dolby Pro Logic

Dolby Pro Logic is a decoding system that was developed to get a better sense of presence from sources encoded with Dolby Surround. The feeling of position has been improved by the addition of a separate center speaker channel.



Software encoded with Dolby Surround can be identified with this mark.

- DVD
- Video tape
- CD
- Video CD

SUPER SURROUND

MOVIE

MUSIC

This mode adds surround effects to movie software that hasn't been recorded with the above systems.

This mode adds surround effects to stereo sources.

Any stereo sound source except for the radio.

SIMULATED STEREO

This mode adds stereo-like effects to monaural sources.

Any monaural sound source except for the radio.

SFC

Use SFC effects to change the sound quality and add reverberation.

Any source.

Other effects

- Ⓐ Virtual rear surround
- Ⓑ Multi rear surround
- Ⓒ Seat position
- Ⓓ Center focus

- Ⓐ Virtual rear surround
- Ⓑ Multi rear surround
- Ⓒ Seat position
- Ⓓ Center focus

- Ⓐ Virtual rear surround
- Ⓑ Multi rear surround
- Ⓒ Seat position

—

—

—

Ⓐ Virtual rear surround (→ page 37)

- This mode is useful if you have to place your surround speakers near the front speakers due to the layout of your room.
- This mode makes it seem like the sound from the surround speakers is coming from behind you.

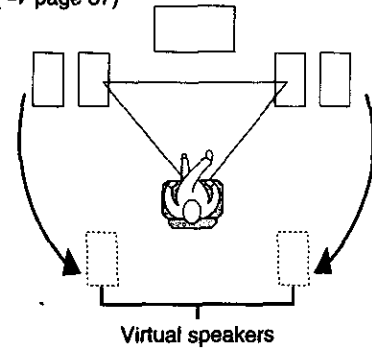

Ⓑ Multi rear surround (→ page 37)

- This mode makes it seem like there are multiple surround speakers in your room, increasing the cinema-like atmosphere.

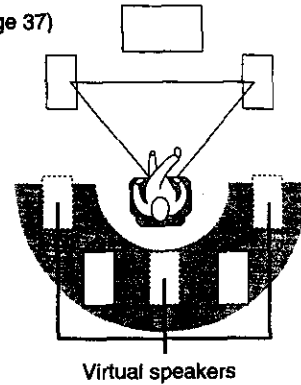

Ⓒ Seat position (→ page 38)

- This mode helps maintain the sound position even if the listening position itself is changed.

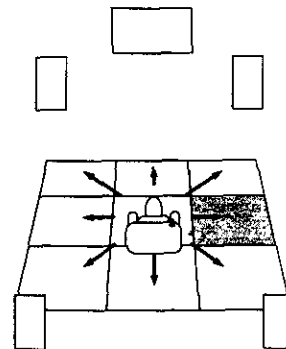

Ⓓ Center focus (→ page 37)

- This mode makes it seem like the sound from the center speaker is coming from within the television.
- The center speaker should be placed on top of the television.

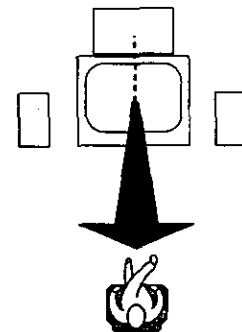

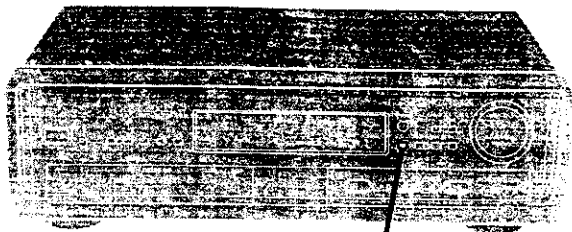

DOLBY PRO LOGIC

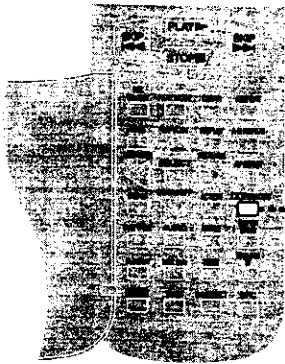

PRO LOGIC

A Enjoying sound with Dolby Digital

DVD

Playback the source (DVD).

"DIGITAL" lights when Dolby Digital signals are detected.

B Enjoying sound with Dolby Pro Logic

Press [DOLBY PRO LOGIC] during play.

Remote control: Press [PRO LOGIC] during play.

To turn off Dolby Pro Logic

Press [DOLBY PRO LOGIC].

Remote control: Press [PRO LOGIC].

Note

Dolby Digital only works in the DVD mode. Dolby Pro Logic cannot be used if the source is radio or if headphones are connected.

A



B

DOLBY PRO LOGIC



PRO LOGIC

VIRTUAL REAR SRND
MULTI REAR SRND
CENTER FOCUS
SEAT POSITION

Remote control only

Adjusting Dolby Digital and Dolby Pro Logic

If the level of the speakers appears to be different while listening to a source, sit where you would normally and perform the following to adjust the level of all the speakers to the same apparent level.

The speaker levels can be adjusted within the following ranges:

- L, R: -16 dB to 0 dB
- C, RS, LS, S: -10 dB to +6 dB
- SW (Subwoofer): -10 dB to +10 dB

Preparations:

To adjust Dolby Digital

Press [DVD/CD].

To adjust Dolby Pro Logic

Press [PRO LOGIC].

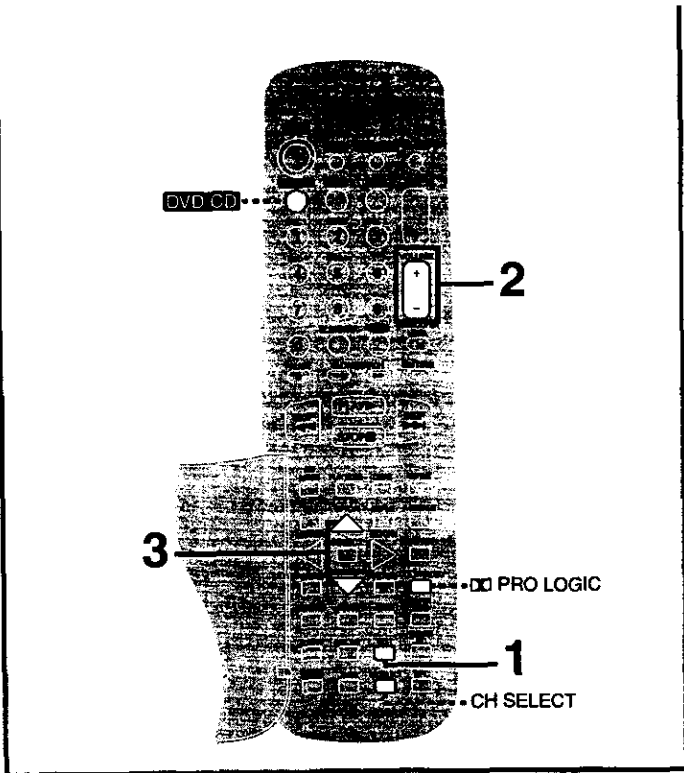

1 Press [TEST] to output a test signal.

The test signal is output in the following order.

DOLBY DIGITAL

- L: Front speaker (left)
- C: Center speaker
- R: Front speaker (right)
- RS: Surround speaker (right)
- LS: Surround speaker (left)
- * No signal is output for the subwoofer.

Dolby Pro Logic

- L: Front speaker (left)
- C: Center speaker
- R: Front speaker (right)
- S: Surround speaker
- * No signal is output for the subwoofer.

2 Press [VOLUME (+ or -)] to set the volume level normally used for enjoying the source.

3 Press [UP/ON △] or [DOWN/OFF ▽] to adjust the level of each speaker to the same apparent level.

In Dolby Pro Logic, only the center (C) and surround (S) channels can be adjusted.

To stop the test signal

Press [TEST].

To adjust speaker level during play

1. Press [CH SELECT] to select the speaker channel.

In Dolby Digital

L → C → R → RS → LS → SW (Subwoofer)

The subwoofer (SW) cannot be selected if it is off.
 (⇒ page 40)

In Dolby Pro Logic

C → S

2. Press [UP/ON △] or [DOWN/OFF ▽].

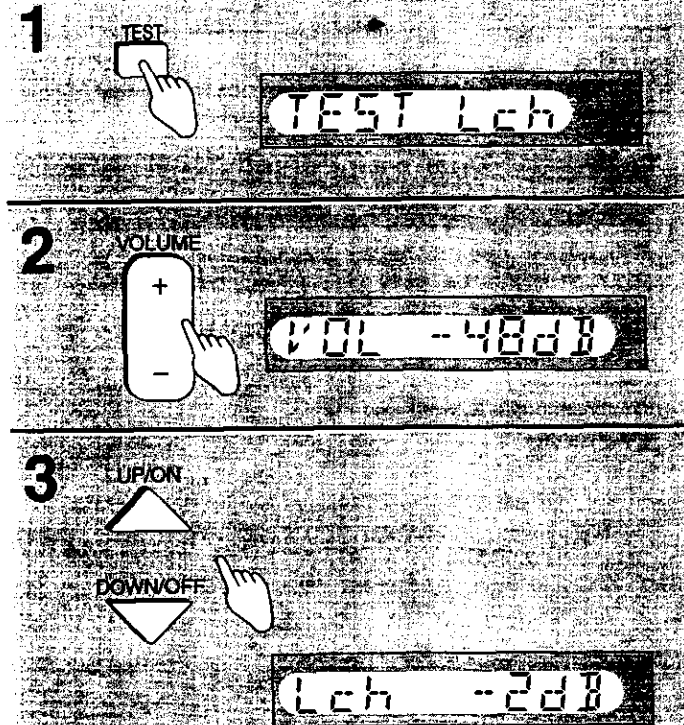

Sound quality/sound field operations

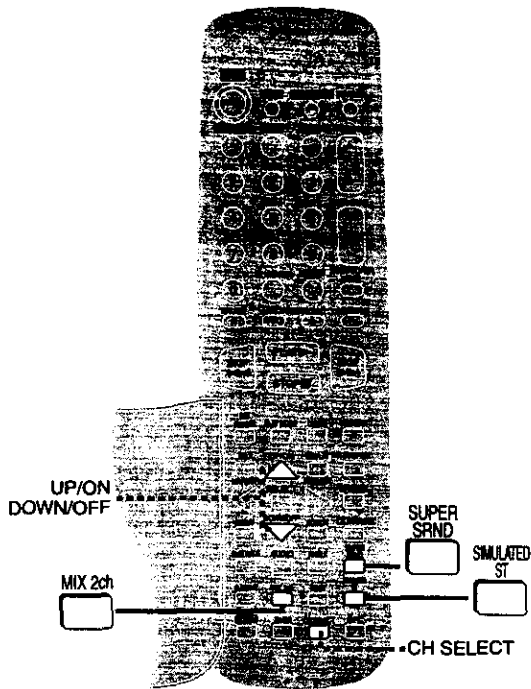

A Enjoying sound with stereophonics (SUPER SRND) Remote control only

Press [SUPER SRND].
 Each time you press the button
 MUSIC → MOVIE → STEREO (off)

To cancel super surround
 Press [SUPER SRND] and select "STEREO".

To adjust the level of the surround speakers
 1. Press [CH SELECT] to select the speaker channel.
 2. Press [UP/ON △] or [DOWN/OFF ▽] to adjust the output level.
 The level can be adjusted between -10 dB and +6 dB.

B Enjoying sound with simulated stereo (SIMULATED ST) Remote control only

Press [SIMULATED ST].
 "SIMULATED ST" will light up on the display.

To cancel simulated stereo
 Press [SIMULATED ST].

Note
 Super surround and simulated stereo cannot be used if the source is radio or if headphones are connected.

C To down mix to 2 channels Remote control only

This function down mixes 5.1 channel audio signal, like Dolby Digital, to two channels to be output through the front speakers.

Press [MIX 2ch].

To cancel down mix to 2 channels
 Press [MIX 2ch].

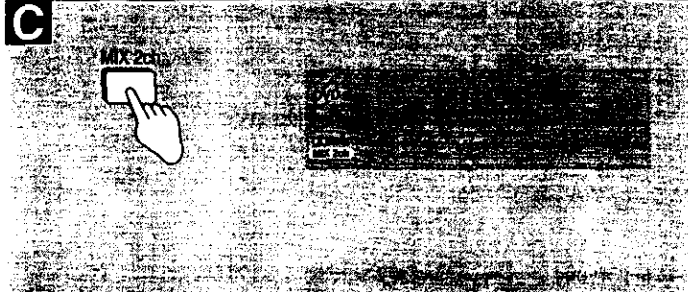
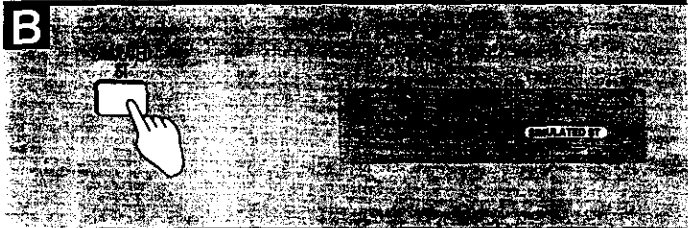
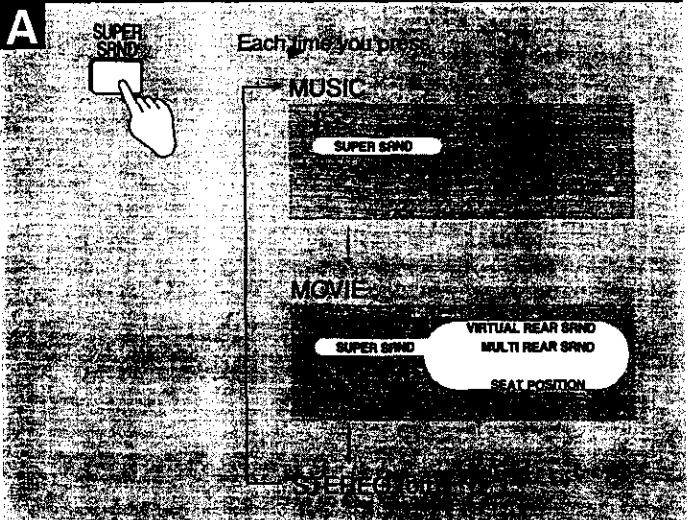

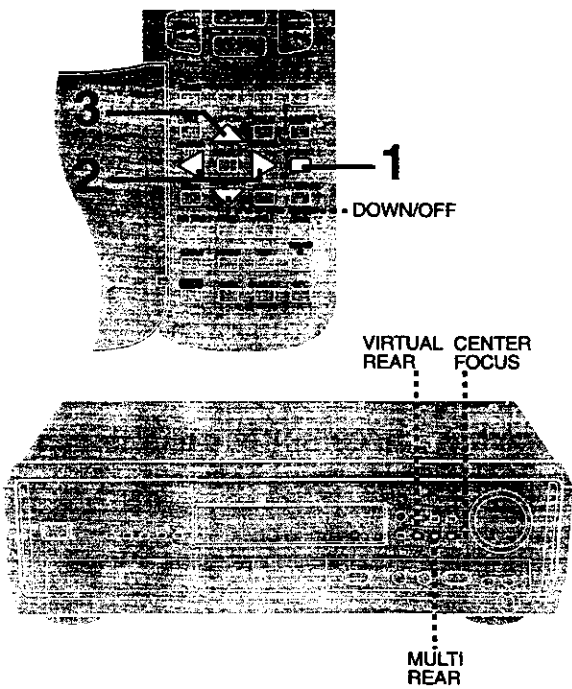

A Using the virtual rear surround effect (VIRTUAL REAR SRND) Remote control

- 1 Press [AV EFFECT].
- 2 Press [◀] or [▶] to select "VIRTUAL REAR SRND".
- 3 While "VIRTUAL REAR SRND" is flashing. Press [UP/ON ▲].

To cancel
After steps 1 and 2, press [DOWN/OFF ▼] (off).

From the main unit
Press [VIRTUAL REAR] to turn on/off.

B Using the multi rear surround effect (MULTI REAR SRND) Remote control

- 1 Press [AV EFFECT].
- 2 Press [◀] or [▶] to select "MULTI REAR SRND".
- 3 While "MULTI REAR SRND" is flashing. Press [UP/ON ▲].

To cancel
After steps 1 and 2, press [DOWN/OFF ▼] (off).

From the main unit
Press [MULTI REAR] to turn on/off.

C Using the center focus effect (CENTER FOCUS) Remote control

- 1 Press [AV EFFECT].
- 2 Press [◀] or [▶] to select "CENTER FOCUS".
- 3 While "CENTER FOCUS" is flashing. Press [UP/ON ▲].

To cancel
After steps 1 and 2, press [DOWN/OFF ▼] (off).

From the main unit
Press [CENTER FOCUS] to turn on/off.

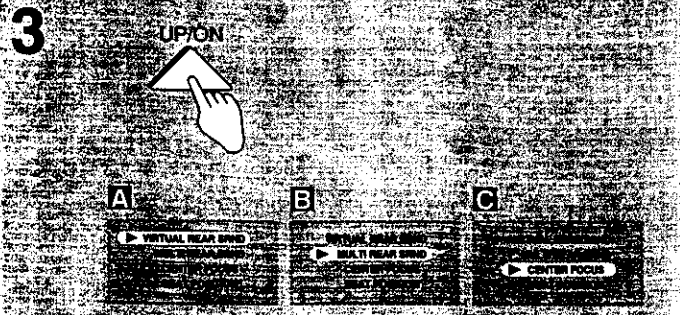
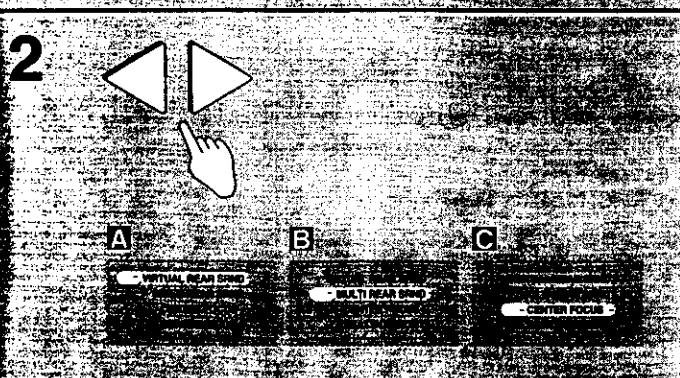
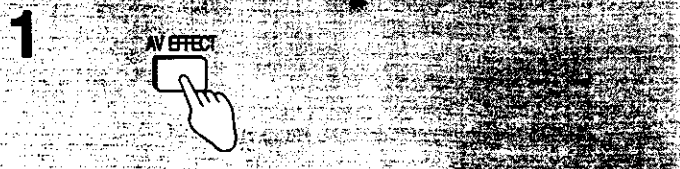

Sound quality/sound field operations



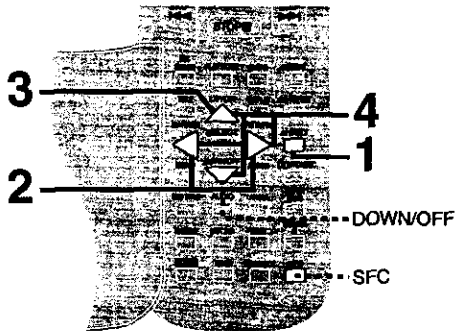
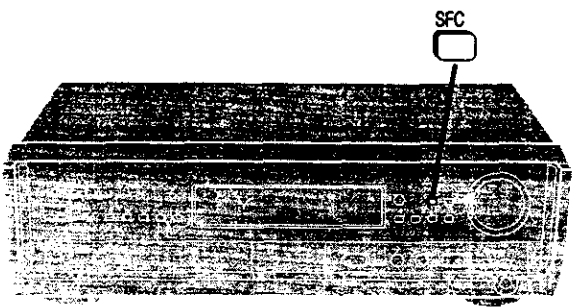

A Using the seat position function (SEAT POSITION) Remote control only

- 1 Press [AV EFFECT].
- 2 Press [◀] or [▶] to select "SEAT POSITION".
- 3 While "SEAT POSITION" is flashing Press [UP/ON ▲].
- 4 While "▶" is flashing Press the cursor buttons to select a position.

While virtual rear surround is on
The seat position is changed in three horizontal steps.

To cancel seat position
After steps 1 and 2, press [DOWN/OFF ▼] (off).

B Sound Field Control effects

SFC can be used with any source.
There are seven SFC modes.
HEAVY: Adds punch to rock.
CLEAR: Clarifies higher sounds.
SOFT: Use this setting for background music.
DISCO: Produces lengthy reverberations like a disco.
LIVE: Adds gloss to vocals.
HALL: Expands the sound to make you feel like you were in a hall.
FLAT: No effect is added.
The factory setting is HEAVY.

Press [SFC].
Remote control: Press [SFC].

To cancel SFC
Press [SFC] to select "FLAT".

A

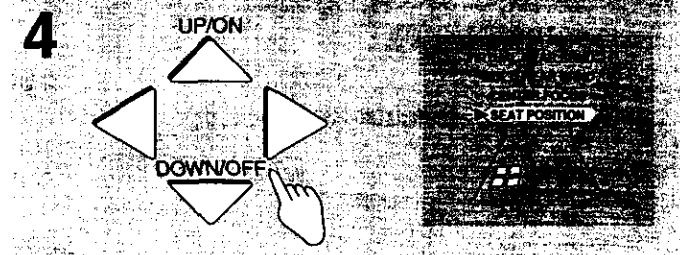
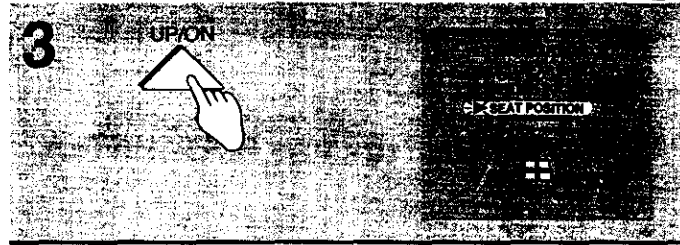
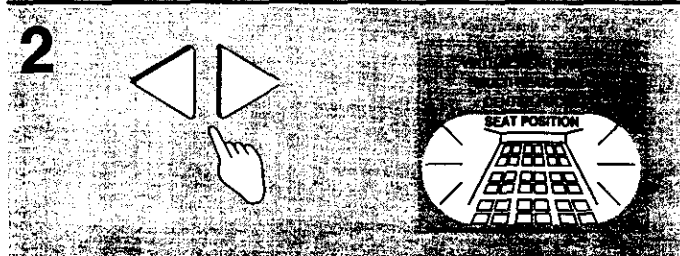

B

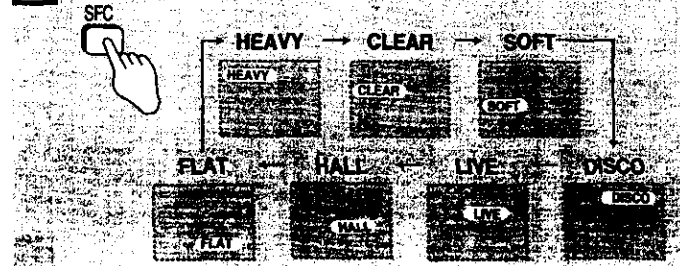

Timer function

Remote control only

There are two timer functions: the sleep timer and the wake timer. They cannot be used together.

- **Sleep timer:**

The unit can be set to turn off after 30, 60, or 90 minutes. The timer is cancelled if the unit is turned off.

- **Wake timer:**

The unit can be set to turn on 5, 7, or 9 hours after it is turned off.

The timer is cancelled if the unit is turned on again.

Setting the timer

1 Press [TIMER] to select the desired timer mode.

The timer mode changes as follows:

SLEEP → WAKE → OFF

2 Press and hold [TIMER] to select the required time.

The display changes as follows:

- **In sleep timer mode:**

30 → 60 → 90 (minutes)

- **In wake timer mode:**

5H → 7H → 9H (hours)

3 **Wake timer mode only**

Press [⏻] to turn off the unit.

Main unit: Press [POWER, ⏻]

The "WAKE" indicator lights up.

Checking the remaining time on the sleep timer and the time set for the wake timer.

Press [TIMER].

To cancel the timer

Press [TIMER] until "OFF" is displayed.

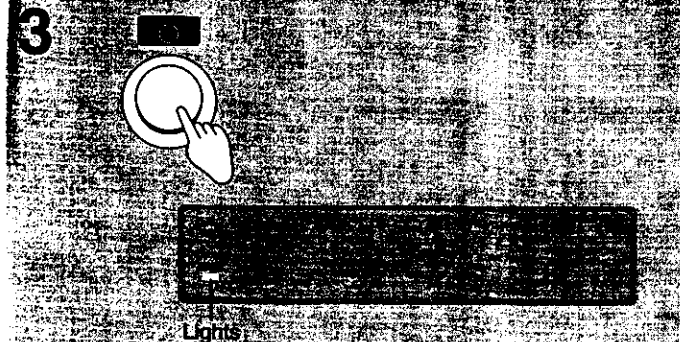
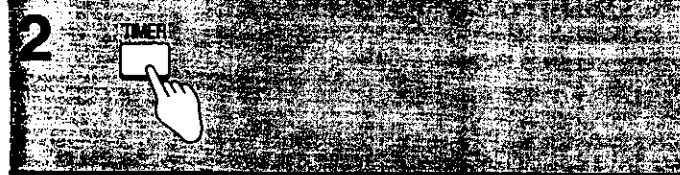
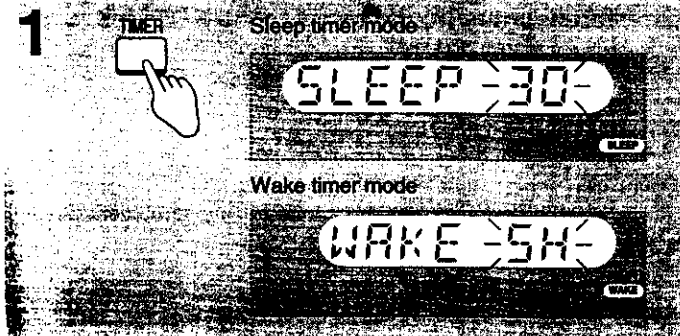
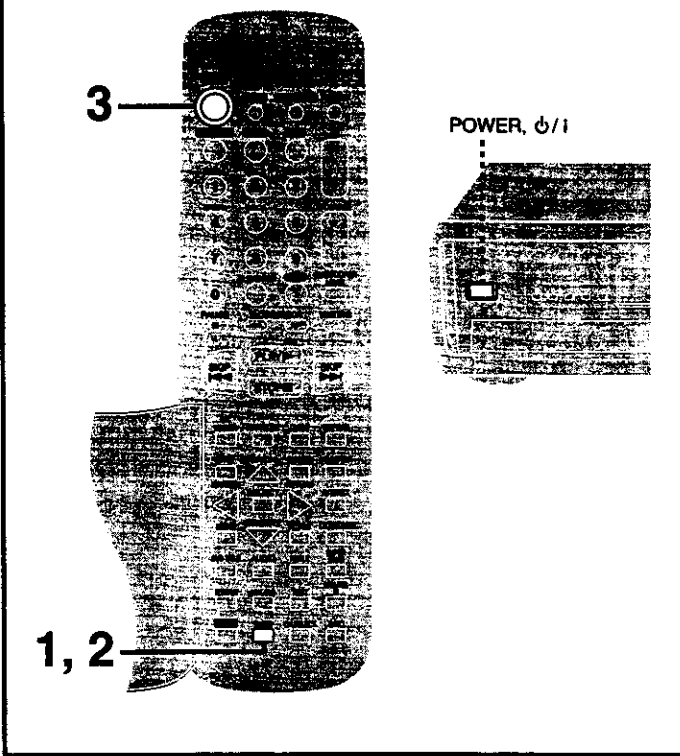

Sound quality/sound field operations, Other functions

Convenient functions

A To mute the volume Remote control only

Press [MUTING].

"MUTING" flashes on the display.

To cancel muting

Press [MUTING] or reduce the volume to minimum and raise it again.

Note

When the system is turned off, the muting operation will be automatically canceled.

B To turn off the unit's display Remote control only

Turning off the display can improve video viewing in a dark or dimly lit room.

Press [FL DISPLAY].

To turn on again

Press [FL DISPLAY].

C To listen through headphones

- ① Reduce the volume.
- ② Connect the headphones to the PHONES jack and adjust the volume.

Audio is automatically switched to stereo.

Headphones

Plug type: 6.3 mm (1/4") stereo

Note

Avoid listening for prolonged periods of time to prevent hearing damage.

D Adjusting the bass

Press [SUBWOOFER LEVEL].

Remote control: Press [SUBWOOFER LEVEL].

Each time you press the button

OFF → 1 → 2 → 3 → 4

The factory setting is "4".

Sound is not heard from the subwoofer if you select "OFF".

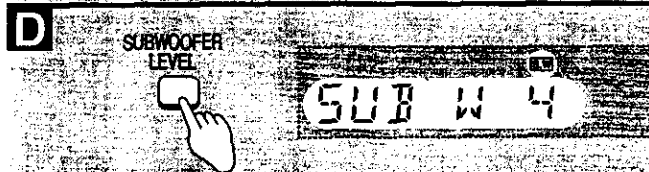
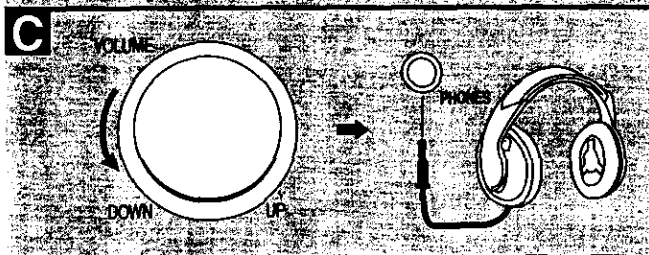
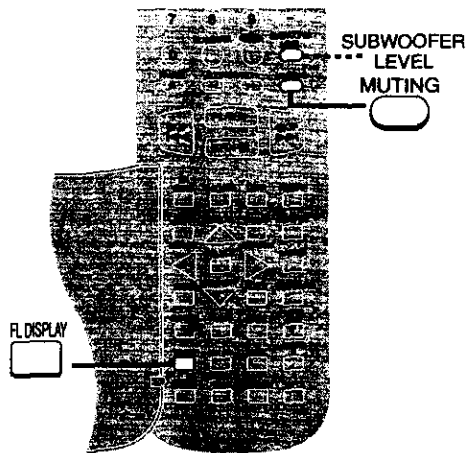
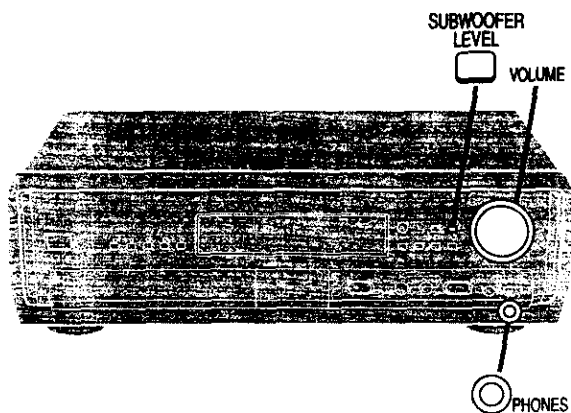

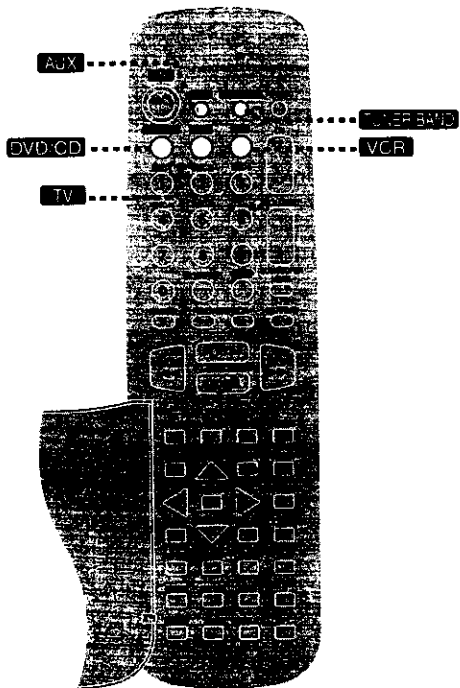
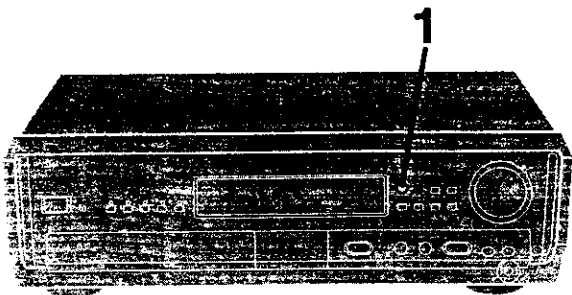

A Listening to an external source

1 Press [SELECTOR] to select "TV", "VCR" or "AUX".

Remote control: Press [TV], [VCR] or [AUX].

2 Start the source.

B Recording to other equipment

Preparation

Connect and prepare the recording equipment (→ page 11).

1 Press [SELECTOR] to select "DVD/CD", "FM" or "AM".

Remote control: Press [DVD/CD] or [TUNER/BAND].

2 Begin recording and start the source.

Note

You cannot record to other equipment if you select "TV", "VCR", or "AUX" as the source.

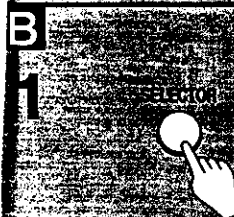
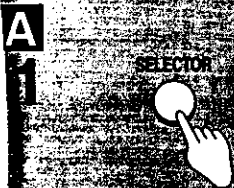

A

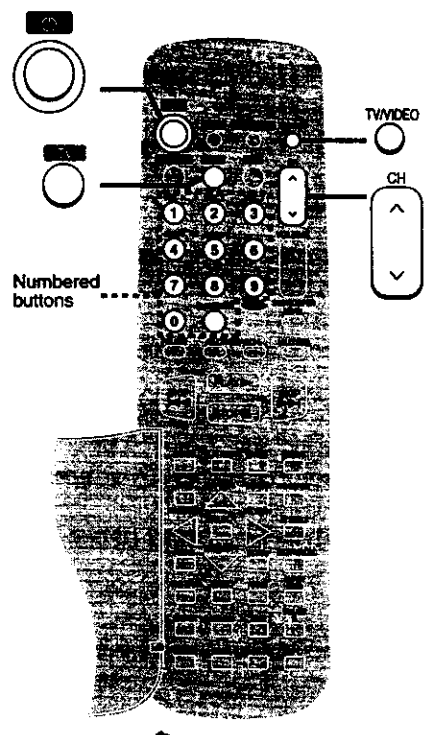

A Operating a television

Switching to TV operation mode

Press [TV].
The main unit also switches to TV.

Turning the TV on

Press [⏻].

Changing channels

Press [CH (^ or v)].
Use the numbered buttons to select the channel.
For channels 10, 11, and 12, press [≥10/ENTER] then the two digits.
10 ch: [≥10/ENTER] → [1] → [0]
11 ch: [≥10/ENTER] → [1] → [1]

Switching the television's video input mode

Press [TV/VIDEO].

B

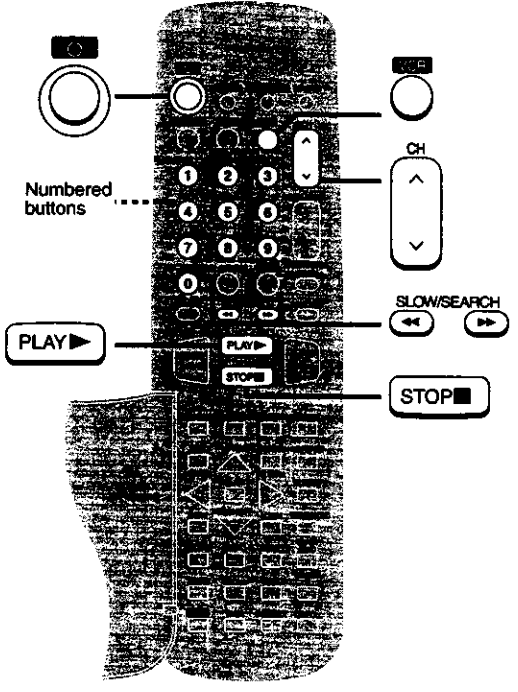

B Operating a video deck

Switching to VCR operation mode

Press [VCR].
The main unit also switches to VCR.

Turning the video deck on

Press [⏻].

Changing channels

Press [CH (^ or v)].
Channels 1 to 10 can also be selected with the numbered buttons.
[0] selects channel 10.

Starting play

Press [PLAY ▶].

Fast-forwarding and rewinding

Press [SLOW/SEARCH (◀◀ or ▶▶)].

To stop play

Press [STOP ■].

Changing the remote control code

Change the remote control code in either of the following circumstances:

- If the Panasonic TV or VCR does not operate as a result of a difference in the remote control code.
- If you wish to operate some other make of TV or VCR.

Note

Even after changing the code there may be cases where certain operations cannot be done or operation is not possible at all.

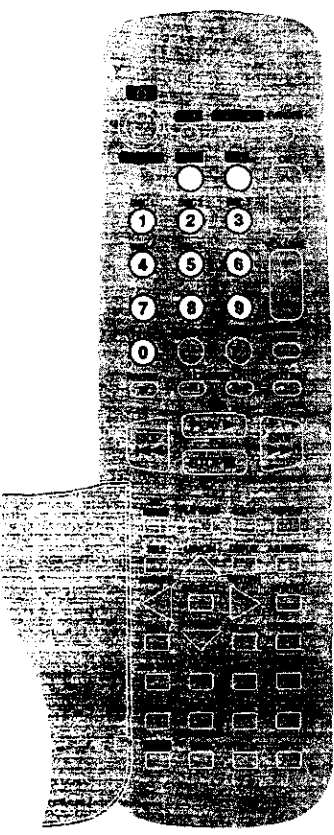

How to change the remote control code

TV



VCR



↓

①

②

③

④

⑤

⑥

⑦

⑧

⑨

⑩

↓

①

②

③

④

⑤

⑥

⑦

⑧

⑨

⑩

Hold down the button corresponding to the component you wish to operate.

Continue to hold the button down and...

Aim the remote control at the component you wish to operate and carefully and slowly press the numbered buttons to enter the appropriate two-digit code number.
(Refer to the table below for the code number.)

When the two-digit code number is entered, the remote control will automatically output the on/off signal.

If the remote control has been correctly changed to the code for the component to be operated, the component will be switched ON or OFF.

Note

If there is more than one code number indicated in the code table, repeat the above procedure until you find a code number for which the power of the component is switched ON or OFF.

TV				VCR			
Manufacturer	Code No.	Manufacturer	Code No.	Manufacturer	Code No.	Manufacturer	Code No.
Panasonic	01, 02	RCA	03, 07, 13	Panasonic	01, 02	RCA	03, 04, 08, 09,
Sony	04	Sanyo	14	Sony	05, 06, 07		10, 11, 12, 23,
G-E	03, 09, 13	Sharp	06, 08, 21	Fisher	13, 14, 15, 18		24, 26
Gold Star	06, 07, 15, 20,	Sylvania	07, 11, 15	Funai	30	Sanyo	18
	22	Symphonic	17, 23	G-E	08, 11	Sharp	16, 17
Hitachi	05, 06, 07	Toshiba	10	Gold Star	27	Shintom	32
JVC	12	Zenith	18	Hitachi	10, 11	Symphonic	30
LXI	07, 11, 13, 14,			JVC	19	Toshiba	23, 24
	15			LXI	10, 13, 15, 18,	Zenith	20
Magnavox	06, 07, 11, 15				27		
Mitsubishi	07, 15, 16			Magnavox	08, 09, 12		
NEC	07, 15			Mitsubishi	21, 22, 28, 29		
Philco	06, 07, 11			NEC	19, 25, 31		
Philips	11			Philco	08, 09		
Pioneer	19			Philips	08, 09, 12		
Quasar	01, 02, 09			Quasar	01, 02, 08, 09		

Note

- This remote control can operate televisions and videos only.
- Some models cannot be operated by this remote control.
- To prevent accidental operation, press [DVD/CD] after operation so the unit is ready to operate this unit.







Summary of initial settings

This chart shows the initial settings for this unit.

The only setting you may have to change is number 5 to suit the kind of television you have connected.

The menu and on-screen message language has been factory preset to English. You can change the language by going to "3 Menu language" and selecting the preferred language.

See page 46 for details on menu operation.

Item	Initial setting		Options	
1. Disc Languages	1. Audio	1. English	1 English 2 French 3 Spanish	4 Original 5 Other * * * *
	2. Subtitle	1. Automatic	1 Automatic 2 English 3 French	4 Spanish 5 Other * * * *
	3. Menus	1. English	1 English 2 French 3 Spanish	4 Other * * * *
2. Ratings	Level 8: All DVDs can be played ▶		Level 8 (All DVDs can be played) to Level 0 (Play of all DVDs is prohibited) You must also set a password if you change the rating to any level other than "8".	
3. Menu Language	1. English		1 English 2 Français	3 Español
4. On-Screen Messages	1. On-Screen Messages	1. On	1. On 2. Off	
	2. Color and Position	1. Blue 	1. Blue  2. Violet  3. Green 	4. Blue  5. Violet  6. Green 
5. TV Aspect	1. 4:3		1. 4:3 2. 16:9	
6. Speaker Settings	Center speaker delay time	0 ms	0 ms 1.3 ms 2.6 ms	3.9 ms 5.3 ms
	Surround speakers delay time	0 ms	0 ms 5.3 ms	10.6 ms 15.9 ms
9. Other Settings	1. Still Mode	1. Automatic	1. Automatic 2. Field 3. Frame	
	2. Audio during Search	1. On	1. On 2. Off	
	3. TV Mode (4:3)	1. Pan & Scan	1. Pan & Scan 2. Letterbox	
	4. D Range Compression	1. Off	1. Off 2. On	
	5. Still Picture Display	1. Off	1. Off 2. On	
	6. Black Level Control	1. Lighter	1. Lighter 2. Darker	

There is no item 7 or 8.

Changes to the initial settings remain intact after the unit is turned off.
Do the setting procedures again to restore to the original settings.

Setting details

Select the soundtrack language. Some discs are designed to start in a certain language despite any changes you make here.

Select the subtitle language. Some discs are designed to start in a certain language despite any changes you make here.

Select the language for the title menu and other menus shown by the disc.

Set a ratings level for playing DVD. The DVDs must have ratings levels recorded on them for this feature to be effective. Discs with this feature will be marked.

Level 8: All DVD can be played.

Level 7 to level 1: Prohibits play of DVD with ratings recorded on them.

Level 0: Prohibits play of all DVD.

Select the language used for menus and messages the unit displays on the television (including these menus).

Choose whether to show the on-screen messages that appear on the television when you perform operations.

Select the color and position of on-screen messages and GUI.

Select the aspect ratio (4:3 or 16:9) to suit your television.

Set the delay time for your center and surround speakers. (⇒ page 47)

Select a picture type for when the picture is paused.

Field: Field stills are shown which are less blurred.

Frame: Frame stills are shown which are sharper.

Select whether to have sound on or off during the first level of fast forward.

Select how software made for a widescreen television is displayed on a regular television. (⇒ page 48)

Select whether to have dynamic range compression on or off during play of Dolby Digital software. Dynamic range is the difference between the loudest sound and the softest sound. By compressing this range, you can listen at low volume but still enjoy clear dialog.

Select whether the picture type (I/P/B) is shown when a DVD is paused.

Lighter or darker DVD picture.

Changing the initial settings

Remote control only

- 1 Press [ACTION] while stopped to display the initial settings menu.
- 2 Press [UP/ON \triangle] or [DOWN/OFF ∇] to highlight the item, and press [SELECT].
- 3 Press the cursor buttons to select the item, and press [SELECT].
Repeat step 3 as the menus require to make the changes.

Note

- You can also make changes with the numbered buttons if there is a number next to the item.
- If you have set "2 Ratings" to "0 Lock All", none of the initial settings can be changed while a DVD is loaded. Remove the DVD to change the settings.

To return to the previous screen

Press [SHIFT] + [DISPLAY, RETURN].

If "0 Exit" is an item in the menu

Press the cursor buttons to select "0 Exit", and press [SELECT].

To enter a 4-digit password after changing the ratings setting

Enter the password with the numbered buttons.

To exit the initial settings menu

Press the cursor buttons to select "0 Exit", and press [SELECT].

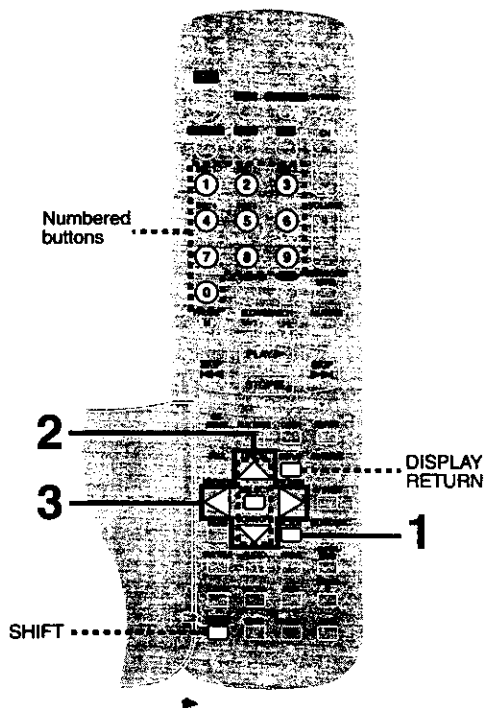

1

ACTION

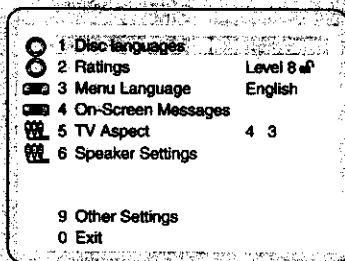

2

UP/ON



DOWN/OFF

SELECT



3

UP/ON

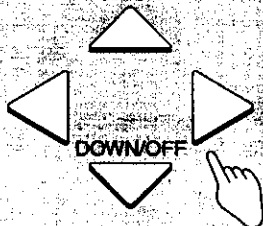

DOWN/OFF

SELECT



Language code list

6565: Afar	7079: Faroese	7678: Lingala	8375: Slovak
6566: Abkhazian	7082: French	7679: Laotian	8376: Slovenian
6570: Afrikaans	7089: Frisian	7684: Lithuanian	8377: Samoan
6577: Ameharic	7165: Irish	7686: Latvian, Lettish	8378: Shona
6582: Arabic	7168: Scots Gaelic	7771: Malagasy	8379: Somali
6583: Assamese	7176: Galician	7773: Maori	8381: Albanian
6588: Aymara	7178: Guarani	7775: Macedonian	8382: Serbian
6590: Azerbaijani	7185: Gujarati	7776: Malayalam	8385: Sundanese
6665: Bashkir	7265: Hausa	7778: Mongolian	8386: Swedish
6669: Byelorussian	7273: Hindi	7779: Moldavian	8387: Swahili
6671: Bulgarian	7282: Croatian	7782: Marathi	8465: Tamil
6672: Bihari	7285: Hungarian	7783: Malay	8469: Telugu
6678: Bengali; Bangla	7289: Armenian	7784: Maltese	8471: Tajik
6679: Tibetan	7365: Interlingua	7789: Burmese	8472: Thai
6682: Breton	7378: Indonesian	7865: Nauru	8473: Tigrinya
6765: Catalan	7383: Icelandic	7869: Nepali	8475: Turkmen
6779: Corsican	7384: Italian	7876: Dutch	8476: Tagalog
6783: Czech	7387: Hebrew	7879: Norwegian	8479: Tonga
6789: Welsh	7465: Japanese	7982: Oriya	8482: Turkish
6865: Danish	7473: Yiddish	8065: Panjabi	8484: Tatar
6869: German	7487: Javanese	8076: Polish	8487: Twi
6890: Bhutani	7565: Georgian	8083: Pashto, Pushto	8575: Ukrainian
6976: Greek	7575: Kazakh	8084: Portuguese	8582: Urdu
6978: English	7576: Greenlandic	8185: Quechua	8590: Uzbek
6979: Esperanto	7577: Cambodian	8277: Rhaeto-Romance	8673: Vietnamese
6983: Spanish	7578: Kannada	8279: Romanian	8679: Volapük
6984: Estonian	7579: Korean	8285: Russian	8779: Wolof
6985: Basque	7583: Kashmiri	8365: Sanskrit	8872: Xhosa
7065: Persian	7585: Kurdish	8368: Sindhi	8979: Yoruba
7073: Finnish	7589: Kirghiz	8372: Serbo-Croatian	9072: Chinese
7074: Fiji	7665: Latin	8373: Singhalese	9085: Zulu

Calculating delay time

The sound from speakers can reach the listening position at different times depending on placement. You can allow for this difference by changing the delay time of the center and surround speakers.

Center speaker delay time

If $D_1 \leq D_3$, then set delay time to 0 ms

If $D_1 > D_3$, then set delay time as follows

Difference between D_1 and D_3	Delay time
50 cm	1.3 ms
100 cm	2.6 ms
150 cm	3.9 ms
200 cm	5.3 ms

Surround speaker delay time

If $D_1 \leq D_2$, then set delay time to 0 ms

If $D_1 > D_2$, then set delay time as follows

Difference between D_1 and D_2	Delay time
200 cm	5.3 ms
400 cm	10.6 ms
650 cm	15.9 ms

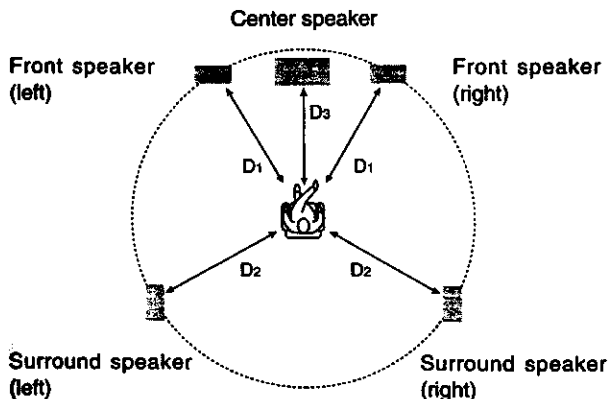

D_1 : The distance from the front speaker
 D_2 : The distance from the surround speaker
 D_3 : The distance from the center speaker

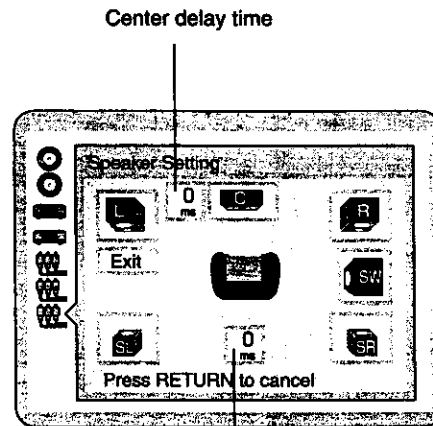

Center delay time

Surround delay time

How different kinds of software appear on your television

DVD software is recorded in a variety of picture formats, and how they appear on your TV depends on the software, the kind of TV you have, and the picture mode your TV is set to.

- Letterbox refers to pictures where black bands appear at the top and bottom.
- Pan & scan refers to pictures where part of the picture is cut off so it fills the whole screen.

Television and picture mode Software format	4:3	16:9 full mode	16:9 zoom mode	16:9 auto mode
Wide screen, pan and scan 	Edges cut off 	Full screen 	Top and bottom cut off 	Full screen 
Wide screen, non-pan and scan 	Letterbox 			
Regular (4:3) 	Full screen 	Screen stretched horizontally 	Top and bottom cut off 	Full screen with black bands on the left and right 
Regular (4:3) letterbox 	Letterbox 	Letterbox with screen stretched horizontally 	Full screen 	Letterbox with extremities of picture stretched 

The names given to the television picture modes depend on the maker of your television. There may also be slight differences in how the pictures appear on the screen. Refer to your television's operating instructions for details.

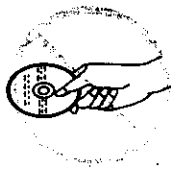
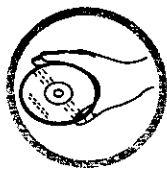
A

Play surface (shiny side)

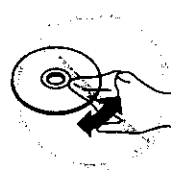
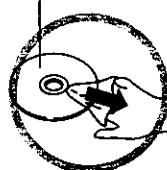

Wipe from inside outward

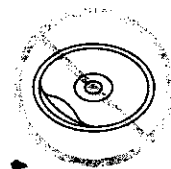
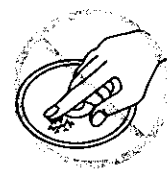
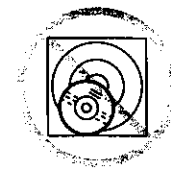
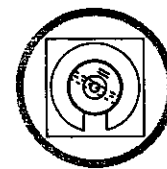
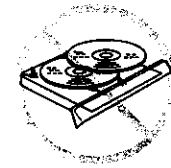
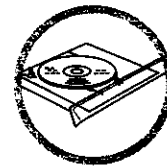
**B**

8 cm

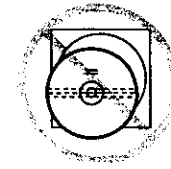
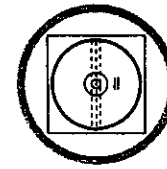

12 cm

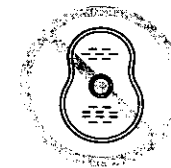
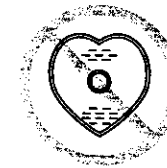
**Concerning discs**

With this system, you can only play discs having these marks. However, do not use irregular shaped discs. Discs of this sort can damage the unit.

**A Handling precautions**

- If you are taking the disc from a cold to a warm environment, moisture may form on the disc. Wipe with a soft, dry lintfree cloth before using the disc.
- Do not write on the label side with a ball-point or other writing instrument.
- Do not use record cleaning sprays, benzene, thinner, static electricity prevention liquids or any other solvent.
- Do not attach labels or stickers to discs. (Do not use discs with exposed adhesive from tape or left over peeled off stickers.)
- Do not use scratch-proof protectors or cover than those specified for use with this system.
- Do not use discs printed with label printers available on the market.

Storage precautions

Be sure to store discs in their cases to protect them from dust, scratches, and warping.

Do not place or store discs in the following places

- Locations exposed to direct sunlight
- Humid or dusty locations
- Locations directly exposed to a heat vent or heating appliance
- In the glove compartment or on the rear deck of an automobile

B To prevent damage

Always observe the following points.

- Load only 1 disc per tray.
- Load discs as shown in figure.
- The adaptor is not needed with 8 cm discs (singles).
- Set the system on a flat, level surface. Do not set it on top of magazines, inclined surfaces, etc.
- Do not move the system while trays are opening/closing, or when loaded.
- Do not put anything except discs in trays.
- Do not use cleaning discs or discs which are badly warped or cracked.
- Do not use discs with poorly attached labels or stickers. Adhesive protruding from underneath stickers or left over from peeled off stickers can cause your stereo to malfunction.
- Do not use irregular shaped discs.

When moving the unit

- 1 Remove all discs.
- 2 Press [POWER] to turn the unit off.
- 3 Disconnect the AC power cord.

Reference

Video

Frame

Frames are the still pictures that go together to make a moving picture. There are about thirty frames shown each second.



Field

One frame is made up of two fields. A regular television shows these fields one after the other to create frames.



One field

Frame still and field still

A still is shown when you pause a moving picture. A frame still is made up of two alternating fields, so the picture may appear blurred, but overall quality is high. A field still is not blurred, but it has only half the information of a frame still so picture quality is lower.

I/P/B

MPEG 2, the video compression standard adapted for use with DVD, codes frames using these three picture types.

I: Intra coded picture (I-picture)

This is the standard picture and is a complete picture in itself. This means it has the best picture quality and is the best to use when adjusting the picture.

P: Predictive coded picture (P-picture)

This picture is calculated based on past I and P-pictures.

B: Bidirectionally-predictive coded picture (B-picture)

This picture is calculated by comparing past and future I and P-pictures so it has the lowest volume of information.

Digital audio

Decoder

A decoder restores the coded audio signals on DVDs to normal. This is called decoding.

Dolby Digital

This method of coding digital signals was developed by Dolby Laboratories. The signals are highly compressed, enabling a large amount of information to be recorded on one disc.

DTS (Digital Theater Systems)

This method of coding digital signals was developed by Digital Theater Systems. The signals are compressed at a low ratio to maintain sound quality.

Sampling rate

This is the number of samples of sound taken per second during conversion to a digital signal. Sampling frequency is expressed in kilohertz (kHz). A high sampling frequency results in a sound close to the original when played back.

Linear PCM (pulse code modulation)

PCM is the usual digital method used for music CDs. DVDs have a greater volume so they use linear PCM, which has a higher sampling rate.

Bitstream

This is the digital form of multiple channel audio data (e.g., 5.1 channel) before it is decoded into its various channels.

Other

Track

This is the smallest division on CD and video CD, and usually equates to a single song.

Chapter

This is the smallest division on DVD and is roughly equivalent to a track.

Title

This is the largest division on DVD.

Playback control (PBC)

This method of controlling disc play is included on version 2.0 video CDs. You are able to interact with the disc through menus.

Maintenance

If the surfaces are dirty

To clean this unit, wipe with a soft, dry cloth.

If the surfaces are extremely dirty, use a soft cloth dipped in a soap-and-water solution or a weak detergent solution.

- Never use alcohol, paint thinner or benzine to clean this unit.
- Before using chemically treated cloth, read the instructions that came with the cloth carefully.

Listening Caution



Selecting fine audio equipment such as the unit you've just purchased is only the start of your musical enjoyment. Now it's time to consider how you can maximize the fun and excitement your equipment offers. This manufacturer and the Electronic Industries Association's Consumer Electronics Group want you to get the most out of your equipment by playing it at a safe level. One that lets the sound come through loud and clear without annoying blaring or distortion-and, most importantly, without affecting your sensitive hearing.

We recommend you to avoid prolonged exposure to excessive noise.

Sound can be deceiving. Over time your hearing "comfort level" adapts to higher volumes of sound. So what sounds "normal" can actually be loud and harmful to your hearing.

Guard against this by setting your equipment at a safe level BEFORE your hearing adapts.

To establish a safe level:

- Start your volume control at a low setting.
- Slowly increase the sound until you can hear it comfortably and clearly, and without distortion.

Once you have established a comfortable sound level:

- Set the dial and leave it there.

Taking a minute to do this now will help to prevent hearing damage or loss in the future. After all, we want you listening for a lifetime.

Apparatus Claims of U.S. Patent Nos. 4,631,603, 4,577,216, and 4,819,098, licensed for limited viewing uses only.

This product incorporates copyright protection technology that is protected by method claims of certain U.S. patents and other intellectual property rights owned by Macrovision Corporation and other rights owners. Use of this copyright protection technology must be authorized by Macrovision Corporation, and is intended for home and other limited viewing uses only unless otherwise authorized by Macrovision Corporation. Reverse engineering or disassembly is prohibited.

Reference

Before requesting service for this unit, check the chart below for a possible cause of the problem you are experiencing. Some simple checks or a minor adjustment on your part may eliminate the problem and restore proper operation. If you are in doubt about some of the check points, or if the remedies indicated in the chart do not solve the problem, refer to the directory of Authorized Service Centers (enclosed with this unit) to locate a convenient service center, or consult your dealer for instructions.

Common problems		Reference pages
<p>No power.</p>	<ul style="list-style-type: none"> • Ensure the power cord is connected. 	<p>10</p>
<p>No sound.</p>	<ul style="list-style-type: none"> • Turn the volume up. • Turn muting off. • Check speaker connections. 	<p>16 40 8</p>
<p>Sounds are unfixed or left and right are reversed.</p>	<ul style="list-style-type: none"> • Check speaker connections. 	<p>8</p>
<p>Humming heard during play</p>	<ul style="list-style-type: none"> • A power cord or fluorescent light is near the cables. Keep other appliances and cords away from this unit's cables. 	<p>—</p>
<p>Sound stops suddenly during play</p>	<ul style="list-style-type: none"> • The speaker cords may have shorted. Turn the unit off and reconnect the cords. 	<p>8</p>
<p>The unit's display is off.</p>	<ul style="list-style-type: none"> • Press [FL DISPLAY] on the remote control to turn the display on. 	<p>40</p>
<p>"ERROR" is displayed.</p>	<ul style="list-style-type: none"> • Incorrect operation performed. Read the instructions and try again. 	<p>—</p>
<p>"F6" is displayed.</p>	<ul style="list-style-type: none"> • The speaker cords may have shorted. Turn the unit off and reconnect the cords. If this does not fix the problem, consult your dealer. 	<p>8</p>
<p>No sound from the subwoofer.</p>	<ul style="list-style-type: none"> • Check that the subwoofer has not been set to "OFF". 	<p>40</p>

Radio		Reference pages
<p>The radio cannot be tuned in or there is a lot of noise and interference.</p>	<ul style="list-style-type: none"> • Adjust the position of the FM or AM antenna. • Turn off nearby televisions, video decks, and satellite receivers. • Separate the antenna from other cables and leads. • You may need an outdoor antenna. 	<p>10 — 11</p>

For detailed instructions, contact an authorized servicer in the U.S.A. and Panasonic Canada Inc. Customer Care Centre in Canada.
 In the U.S.A. 1-800-211-7262 or web site (<http://www.panasonic.com>)
 In Canada 905-624-5505 or web site (www.panasonic.ca)

Disc		Reference pages
<p>The display is wrong or play won't start.</p>	<ul style="list-style-type: none"> • The disc may be upside down. • Replace the disc if it is scratched, warped, or nonstandard. • Condensation may have formed in the player due to a sudden change in temperature. Wait about an hour for it to clear and try again. 	<p>15 49 49 —</p>
<p>Certain sections cannot be played.</p>	<ul style="list-style-type: none"> • Wipe the disc with a soft cloth if it is dirty. 	<p>49</p>
<p>Noise is output when a CD is played.</p>	<ul style="list-style-type: none"> • Check the disc. If it is a DTS CD, it cannot be played. 	<p>—</p>
<p>"DTS NO AUDIO" appears on the display.</p>	<ul style="list-style-type: none"> • This unit is unable to decode DTS signals. 	<p>—</p>
<p>"DVD UB" appears on the display.</p>	<ul style="list-style-type: none"> • The disc is dirty. Wipe it with a soft cloth. 	<p>49</p>
<p>"DVD H" appears on the display.</p>	<ul style="list-style-type: none"> • A problem has occurred. Turn the unit off and unplug the AC cord. Wait a moment and then plug the cord in and turn on the unit again. If the unit is still not working correctly, consult your dealer. 	<p>—</p>
<p>"DISC/TAKE OUT" appears on the display.</p>	<ul style="list-style-type: none"> • A problem has occurred with the tray mechanism. The tray will open automatically. Take out the disc and close the tray. The unit will make the disc changing noises for a few moments and then should operate normally. 	<p>—</p>
<p>You have forgotten your ratings password.</p>	<ul style="list-style-type: none"> • Reset the unit to its original factory settings. Do the following to restore the unit to the condition it was in at the time of shipment. This clears the ratings settings. Press [■] on the main unit and [≥10/ENTER] on the remote control at the same time for about 3 seconds until the message "Initialized" disappears from the television screen. 	<p>—</p>
<p>Languages you selected in the initial settings menu are not used for the sound track and subtitles.</p>	<ul style="list-style-type: none"> • The selected languages are not recorded on the DVD or the DVD has been designed to automatically play a certain language. 	<p>44, 45</p>

The remote control		Reference pages
<p>The remote control doesn't work.</p>	<ul style="list-style-type: none"> • Check the batteries are inserted correctly. • Aim the remote control at the main unit and remove obstacles between them. • Replace the batteries if they are worn. • If the remote control doesn't operate the television, try changing the code. This remote control cannot operate some televisions. It may be in the TV or VCR operation mode. Press [DVD/CD] to operate this unit. 	<p>6 6 — 42, 43</p>

Reference

■ **AMPLIFIER SECTION**

FTC TTL POWER OUTPUT	240 W
120 Hz–20 kHz, 1.0 % total harmonic distortion	
FRONT	30 W per ch (6 Ω)
CENTER	30 W (6 Ω)
SURROUND	30 W per ch (6 Ω)
45–120 Hz, 1.0 % total harmonic distortion	
SUBWOOFER	90 W (6 Ω)
Input sensitivity/input impedance	
AUX	250 mV, 10 kΩ

■ **FM TUNER SECTION**

Frequency range	87.9–107.9 MHz (200 kHz steps)
	87.5–108.0 MHz (100 kHz steps)
Sensitivity	16.3 dBf (1.8 μV, IHF)
Antenna terminals	75 Ω unbalanced

■ **AM TUNER SECTION**

Frequency range	520–1710 kHz (10 kHz steps)
Sensitivity	
S/N 20 dB at 1000 kHz	500 μV

■ **DISC SECTION**

Disc	
DVD	8 cm/12 cm single-sided, single-layer 8 cm/12 cm single-sided, double-layer 8 cm/12 cm double-sided, double-layer (one layer per side) 8 cm/12 cm
CD/V-CD	8 cm/12 cm
Video	
Signal system	NTSC
Output level	Composite video 1 Vp-p (75 Ω)
S-video Y	1 Vp-p (75 Ω)
S-video C	0.286 Vp-p (75 Ω/NTSC)
Audio	
Sampling frequency	
CD	44.1 kHz
DVD	48 kHz/96 kHz
Decoding	16/20/24 bit linear
Wow and flutter	Less than possible measurement data
Digital filter	8 fs
D/A converter	Delta-sigma DAC
Pick up	
Beam Source	Semiconductor Laser
Wavelength	665 nm

■ **SPEAKER SECTION**

Front and surround speakers (SB-AFC80)

Type	1 way 1 speaker Bass-ref.
Speaker unit	
Fullrange	8 cm cone type
Impedance	6 Ω
Input power	
MUSIC	60 W
DIN	30 W
Sound pressure level	79 dB/W (1.0 m)
Frequency response	80 Hz–22 kHz (–16 dB) 110 Hz–20 kHz (–10 dB)
Dimensions (W x H x D)	88 x 158 x 105 mm (3-15/32" x 6-7/32" x 4-1/8")
Weight	Approx. 0.8 kg (1.8 lb.)

Center speaker (SB-AFC285)

Type	2 way 2 speaker Bass-ref.
Speaker unit	
Woofer	10 cm cone type
Tweeter	6 cm cone type
Impedance	6 Ω
Input power	
MUSIC	60 W
DIN	30 W
Sound pressure level	83 dB/W (1.0 m)
Crossover frequency	4 kHz
Frequency response	67 Hz–22 kHz (–16 dB) 92 Hz–20 kHz (–10 dB)
Dimensions (W x H x D)	208 x 120 x 163 mm (8-3/16" x 4-3/4" x 6-7/16")
Weight	Approx. 1.9 kg (4.2 lb.)

Subwoofer (SB-W80)

Type	1 way 1 speaker Bass-ref.
Speaker unit	
Woofer	17 cm cone type
Impedance	6 Ω
Input power	
MUSIC	180 W
DIN	90 W
Sound pressure level	80 dB/W (1.0 m)
Frequency response	41 Hz–1.8 kHz (–16 dB) 45 Hz–1.6 kHz (–10 dB)
Dimensions (W x H x D)	200 x 450 x 300 mm (7-7/8" x 17-23/32" x 11-13/16")
Weight	Approx. 5.9 kg (13.0 lb.)

■ **GENERAL**

Power supply	AC 120 V, 60 Hz
Power consumption	190 W
Standby	0.25 W
Dimensions (W x H x D)	430 x 136 x 400 mm (16-15/16" x 5-11/32" x 15-3/4")
Weight	Approx. 8.7 kg (19.31 lb.)

Note:

- Specifications are subject to change without notice. Weight and dimensions are approximate.
- Total harmonic distortion is measured by the digital spectrum analyzer.

Do not attempt to remove the cover (s) or repair the unit yourself. Refer servicing to qualified personnel only. The servicer will require all components to service your system. Therefore, should service ever be necessary, be sure to bring the entire system.

Product Information

For product service, product information or assistance with product operation, refer to the servicer directory.

THE FOLLOWING APPLIES ONLY IN THE U.S.A.

CAUTION:

This equipment has been tested and found to comply with the limits for a Class B digital device, pursuant to Part 15 of the FCC Rules.

These limits are designed to provide reasonable protection against harmful interference in a residential installation. This equipment generates, uses and can radiate radio frequency energy and, if not installed and used in accordance with the instructions, may cause harmful interference to radio communications. However, there is no guarantee that interference will not occur in a particular installation. If this equipment does cause harmful interference to radio or television reception, which can be determined by turning the equipment off and on, the user is encouraged to try to correct the interference by one of the following measures:

- Reorient or relocate the receiving antenna.
- Increase the separation between the equipment and receiver.
- Connect the equipment into an outlet on a circuit different from that to which the receiver is connected.
- Consult the dealer or an experienced radio/TV technician for help.

Any unauthorized changes or modifications to this equipment would void the user's authority to operate this device.

This device complies with Part 15 of the FCC Rules. Operation is subject to the following two conditions: (1) This device may not cause harmful interference, and (2) this device must accept any interference received, including interference that may cause undesired operation.

Reference

ONLY FOR U.S.A.

Panasonic

Technics

Quasar

*For Product Information, Operating Assistance, Literature Request, Dealer Locations, and all Customer Service inquiries please contact:
1-800-211-PANA (7262), Monday-Friday 9 am-9 pm; Saturday-Sunday 9 am-7 pm, EST.*

*Web Site: <http://www.panasonic.com>
You can purchase parts, accessories or locate your nearest servicer by visiting our Web Site.*

Accessory Purchases:

1-800-332-5368 (Customer Orders Only)
Panasonic Services Company 20421 84th Avenue South, Kent, WA 98032 (6 am to 5 pm Monday-Friday; 6 am to 10:30 am Saturday; PST)
(Visa, MasterCard, Discover Card, American Express, Check)

Factory Servicers Locations			
<p>CALIFORNIA 6550 Katella Avenue Cypress, CA 90630</p> <p>800 Dubuque Avenue S. San Francisco CA 94080</p> <p>20201 Sherman Way Suite 102 Canoga Park, CA 91306</p> <p>3878 Ruffin Road Suite A San Diego, CA 92123</p> <p>COLORADO 1640 South Abilene Street Suite D Aurora, CO 80012</p> <p>FLORIDA 3700 North 29th Avenue Suite 102 Hollywood, FL 33020</p>	<p>GEORGIA 8655 Roswell Road Suite 100 Atlanta, GA 30350</p> <p>ILLINOIS 9060 Golf Road Niles, IL 60714</p> <p>1703 North Randall Road Elgin, IL 60123 (Pick-up/Drop-off only)</p> <p>MARYLAND 62 Mountain Road Glen Burnie, MD 21061</p> <p>MASSACHUSETTS 60 Glacier Drive Suite G Westwood, MA 02090</p>	<p>MICHIGAN 37048 Van Dyke Avenue Sterling Heights, MI 48312</p> <p>MINNESOTA 7850-12th Avenue South Airport Business Center Bloomington, MN 55425</p> <p>OHIO 2236 Waycross Road Civic Center Plaza Forest Park, OH 45240</p> <p>PENNSYLVANIA 2221 Cabot Blvd. West Suite B Langhorne, PA 19047</p> <p>Chartiers Valley Shopping Center 1025 Washington Pike Bridgeville, PA 15017</p>	<p>TENNESSEE 3800 Ezell Road Suite 806 Nashville, TN 37211</p> <p>TEXAS 7482 Harwin Drive Houston, TX 77036</p> <p>13615 Welch Road Suite 101 Farmers Branch TX 75244</p> <p>WASHINGTON 20425-84th Avenue South Kent, WA 98032</p> <p>HAWAII 99-859 Iwaiwa Street Aiea, Hawaii 96701 Phone (808) 488-1996 Fax (808) 486-4369</p>

Service in Puerto Rico
Matsushita Electric of Puerto Rico, Inc. Panasonic Sales Company/Factory Servicer:
Ave. 65 de Infantería, Km. 9.5, San Gabriel Industrial Park, Carolina, Puerto Rico 00985
Phone (787) 750-4300 Fax (787) 768-2910

Panasonic Consumer Electronics Company, Division of Matsushita Electric Corporation of America
One Panasonic Way Secaucus, New Jersey 07094
<http://www.panasonic.com>

Panasonic Sales Company, Division of Matsushita Electric of Puerto Rico, Inc. ("PSC")
Ave. 65 de Infantería, Km. 9.5 San Gabriel Industrial Park, Carolina, Puerto Rico 00985

Panasonic Canada Inc.
5770 Ambler Drive
Mississauga, Ontario
L4W 2T3
www.panasonic.ca

