

Panasonic®

CD Stereo System

Operating Instructions

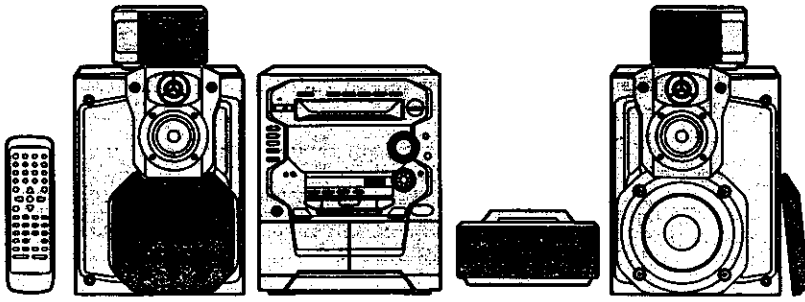

Model No. **SC-AK78**

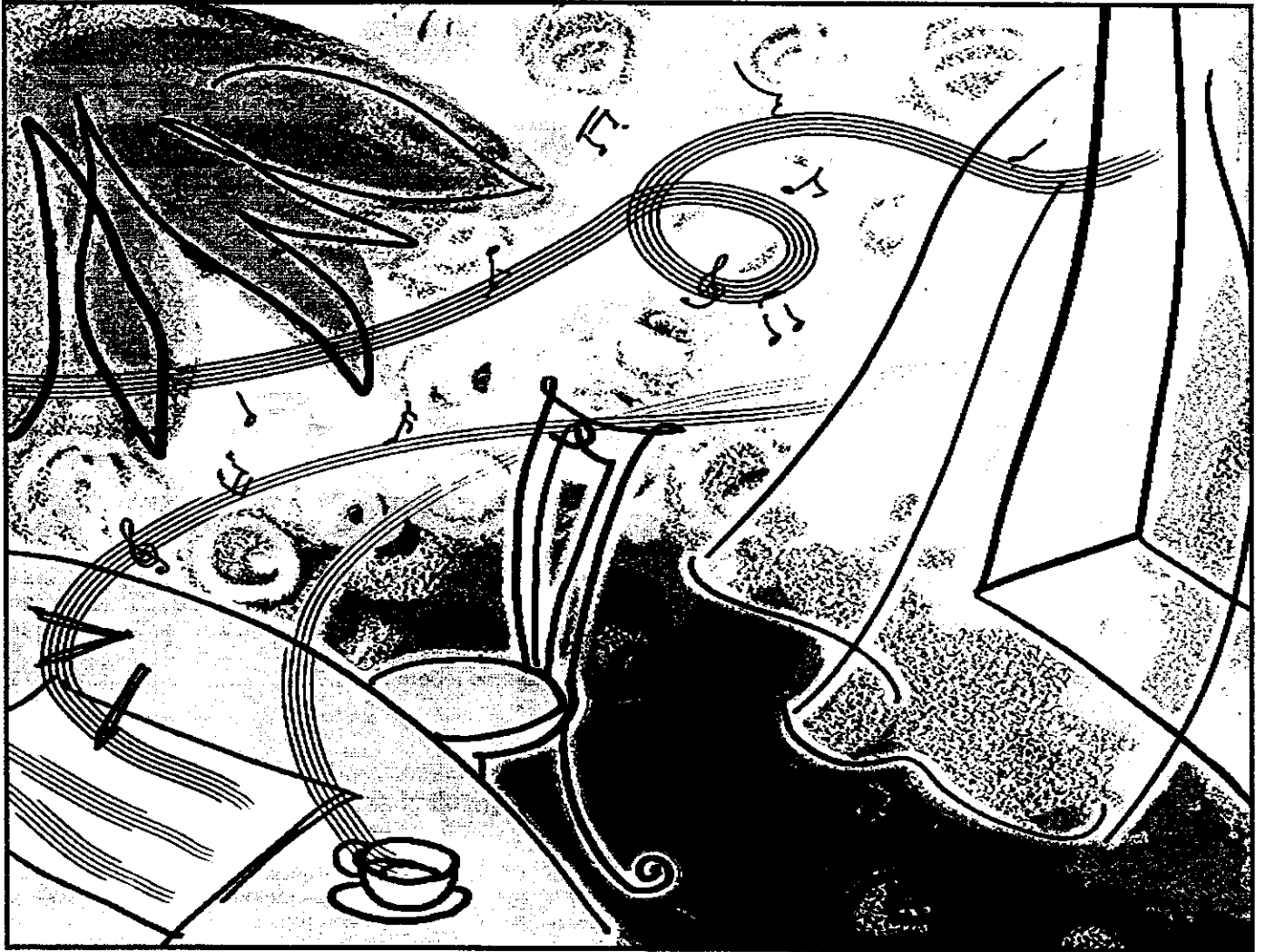

COMPACT
disc
DIGITAL AUDIO

Before connecting, operating or adjusting this product, please read these instructions completely.
Please keep this manual for future reference.

P PC

RQT5289-1P

Dear customer

Thank you for purchasing this product.
For optimum performance and safety, please read these instructions carefully.

These operating instructions are applicable to the following system.

System		SC- AK78
Main unit		SA- AK78
Speakers	Front	SB- AK78
	Surround	SB- PS70
	Center	SB- PC70

The model number and serial number of this product can be found on either the back or the bottom of the unit. Please note them in the space provided below and keep for future reference.

MODEL NUMBER _____

SERIAL NUMBER _____

User memo:

DATE OF PURCHASE _____

DEALER NAME _____

DEALER ADDRESS _____

TELEPHONE NUMBER _____

CAUTION!

THIS PRODUCT UTILIZES A LASER. USE OF CONTROLS OR ADJUSTMENTS OR PERFORMANCE OF PROCEDURES OTHER THAN THOSE SPECIFIED HEREIN MAY RESULT IN HAZARDOUS RADIATION EXPOSURE. DO NOT OPEN COVERS AND DO NOT REPAIR YOURSELF. REFER SERVICING TO QUALIFIED PERSONNEL.

CAUTION:

TO PREVENT ELECTRIC SHOCK MATCH WIDE BLADE OF PLUG TO WIDE SLOT, FULLY INSERT.

Before use

Supplied accessories 2
 Precautions 4
 Concerning the remote control 5
 Placement of speakers 6
 Connections 7
 Front panel controls 10

Preparations

Turning the demo function off 12
 Economy mode 12
 Setting the time 13
 Auto power-off 13
 Presetting radio broadcasts 14

Radio operation

Listening to radio broadcasts 15

CD operation

Listening to compact discs 16
 Loading and checking CDs 16
 Sequential play 17
 Random play 18
 Repeat play 18
 Direct access play 18
 Program play 19
 To listen to special CDs and tracks 20

Tape deck operation

Listening to tapes 21

Recording operation

Before recording 22
 Recording from radio broadcasts 23
 Recording from compact discs 24
 Sequential recording 24
 To record special CDs and tracks 25
 Tape-to-tape recording 26

Supplied accessories

Please check and identify the supplied accessories. Use numbers indicated in parentheses when asking for replacement parts.

(Only for U.S.A.)

To order accessories contact 1-800-332-5368 or web site (<http://www.panasonic.com>).



- AC power supply cord (RJA0065-A) 1 pc.



Note

The included AC power supply cord is for use with this unit only. Do not use it with other equipment.

- FM indoor antenna (RSA0006-J) 1 pc.



Before use

Sound quality / sound field operations

Boosting the super woofer	27
Using the built-in sound quality/sound field settings	27
Varying the sound quality with the manual equalizer	28
Varying the sound quality with the acoustic image equalizer	29
Tri-amp control	29
Surround systems	30
6CH DISCRETE INPUT mode	32
Enjoying sound with DOLBY PRO LOGIC	33
To playback a DOLBY PRO LOGIC source	33
Enjoying sound with stereophonics	34
Enjoying sound with simulated stereo	34
Using the virtual rear surround effect	35
Using the multi rear surround effect	35
Using the center focus effect	35
Using the 3D ENHANCED effect	36
Using the seat position function	36

Timer and others

Using the timer	37
Using the play timer	37
Using the record timer	38
Using the play/record timer	39
Using the sleep timer	39
Using an external unit	40
Convenient functions	40

Reference

Concerning compact discs	41
Concerning cassette tapes	41
Troubleshooting guide	42
Maintenance	43
Specifications	backcover
Product service	backcover

AM loop antenna (RSA0029) 1 pc.



Remote control transmitter (RAK-SA958WK) 1 pc.

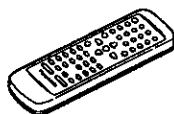

Remote control batteries 2 pcs.

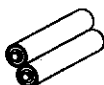

THE FOLLOWING APPLIES ONLY IN THE U.S.A.:

CAUTION:

This equipment has been tested and found to comply with the limits for a Class B digital device, pursuant to Part 15 of the FCC Rules.

These limits are designed to provide reasonable protection against harmful interference in a residential installation. This equipment generates, uses and can radiate radio frequency energy and, if not installed and used in accordance with the instructions, may cause harmful interference to radio communications. However, there is no guarantee that interference will not occur in a particular installation. If this equipment does cause harmful interference to radio or television reception, which can be determined by turning the equipment off and on, the user is encouraged to try to correct the interference by one of the following measures:

- Reorient or relocate the receiving antenna.
- Increase the separation between the equipment and receiver.
- Connect the equipment into an outlet on a circuit different from that to which the receiver is connected.
- Consult the dealer or an experienced radio/TV technician for help.

Any unauthorized changes or modifications to this equipment would void the user's authority to operate this device.

This device complies with Part 15 of the FCC Rules. Operation is subject to the following two conditions: (1) This device may not cause harmful interference, and (2) this device must accept any interference received, including interference that may cause undesired operation.

WARNING:

TO REDUCE THE RISK OF FIRE, ELECTRIC SHOCK OR PRODUCT DAMAGE, DO NOT EXPOSE THIS APPLIANCE TO RAIN, SPLASHING, DRIPPING OR MOISTURE.



CAUTION

RISK OF ELECTRIC SHOCK
DO NOT OPEN



CAUTION: TO REDUCE THE RISK OF ELECTRIC SHOCK, DO NOT REMOVE SCREWS. NO USER-SERVICEABLE PARTS INSIDE. REFER SERVICING TO QUALIFIED SERVICE PERSONNEL.



The lightning flash with arrowhead symbol, within an equilateral triangle, is intended to alert the user to the presence of uninsulated "dangerous voltage" within the product's enclosure that may be of sufficient magnitude to constitute a risk of electric shock to persons.



The exclamation point within an equilateral triangle is intended to alert the user to the presence of important operating and maintenance (servicing) instructions in the literature accompanying the appliance.

Before using this unit please read these operating instructions carefully. Take special care to follow the warnings indicated on the unit itself as well as the safety suggestions listed below. Afterwards keep them handy for future reference.

Before use

Safety

- 1. Power Source**—The unit should be connected to power supply only of the type described in the operating instructions or as marked on the unit.
- 2. Polarization**—If the unit is equipped with a polarized AC power plug (a plug having one blade wider than the other), that plug will fit into the AC outlet only one way. This is a safety feature. If you are unable to insert the plug fully into the outlet, try reversing the plug. If the plug should still fail to fit, contact your electrician to replace your obsolete outlet. Do not defeat the safety purpose of the polarized plug.
- 3. Power Cord Protection**—AC power supply cords should be routed so that they are not likely to be walked on or pinched by items placed upon or against them. Never take hold of the plug or cord if your hand is wet, and always grasp the plug body when connecting or disconnecting it.
- 4. Nonuse Periods**—When the unit is not used, turn the power off. When left unused for a long period of time, the unit should be unplugged from the household AC outlet.

Installation

Environment

- 1. Outdoor Antenna Grounding**—If an outside antenna is connected to the receiver, be sure the antenna system is grounded so as to provide some protection against voltage surges and built-up static charges. Section 810 of the National Electrical Code, ANSI/NFPA No. 70-1990, provides information with respect to proper grounding of the mast and supporting structure, grounding of the lead-in wire to an antenna discharge unit, size of grounding conductors, location of antenna-discharge unit, connection to grounding electrodes, and requirements for the grounding electrode. See figure below.

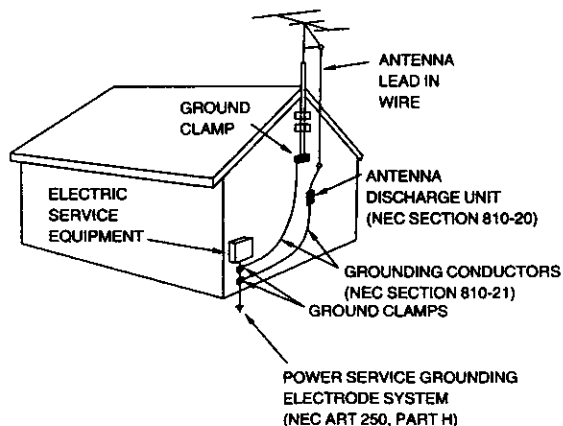

NEC—NATIONAL ELECTRICAL CODE

- 2. Water and Moisture**—Do not use this unit near water—for example, near a bathtub, washbowl, swimming pool, or the like. Damp basements should also be avoided.

- 3. Heat**—The unit should be situated away from heat sources such as radiators and the like. It also should not be placed in temperatures less than 5°C (41°F) or greater than 35°C (95°F).
- 4. Condensation**—Moisture may form on the lens in the following conditions...
 - immediately after a heater has been turned on.
 - in a steamy or very humid room.
 - when the unit is suddenly moved from a cold environment to a warm one.
 If moisture forms inside this unit, it may not operate properly. To correct this problem, turn on the power and wait about one hour for the moisture to evaporate.

Placement

- 1. Ventilation**—The unit should be situated so that its location or position does not interfere with its proper ventilation. Allow 10 cm (4") clearance from the rear of the unit.
- 2. Foreign Material**—Care should be taken so that objects do not fall into and liquids are not spilled into the unit. Do not subject this unit to excessive smoke, dust, mechanical vibration, or shock.
- 3. Magnetism**—The unit should be situated away from equipment or devices that generate strong magnetic fields.
- 4. Stacking**—Do not place heavy objects, other than system components, on top of the unit.
- 5. Surface**—Place the unit on a flat, level surface.
- 6. Carts and Stands**—The unit should be used only with a cart or stand that is recommended by the manufacturer. The unit and cart combination should be moved with care. Quick stops, excessive force, and uneven surfaces may cause the unit and cart combination to overturn.
- 7. Wall or Ceiling Mounting**—The unit should not be mounted to a wall or ceiling, unless specified in this operating instructions.



Maintenance

(See page 43 for details.)

Clean the cabinet, panel and controls with a soft cloth lightly moistened with mild detergent solution. Do not use any type of abrasive pad, scouring powder or solvent such as alcohol or benzene.

Service

- 1. Damage Requiring Service**—The unit should be serviced by qualified service personnel when:
 - (a) The AC power supply cord or the plug has been damaged; or
 - (b) Objects have fallen or liquid has been spilled into the unit; or
 - (c) The unit has been exposed to rain; or
 - (d) The unit does not appear to operate normally or exhibits a marked change in performance; or
 - (e) The unit has been dropped, or the enclosure damaged.
- 2. Servicing**—The user should not attempt to service the unit beyond that described in the operating instructions. All other servicing should be referred to an authorized service personnel.
For the address of an authorized servicenter:
In the U.S.A. 1-800-211-7262 or web site
(<http://www.panasonic.com>)
In Canada 905-624-5505 or web site
(www.panasonic.ca)

Listening caution



Selecting fine audio equipment such as the unit you've just purchased is only the start of your musical enjoyment. Now it's time to consider how you can maximize the fun and excitement your equipment offers. This manufacturer and the Electronic Industries Association's Consumer Electronics Group want you to get the most out of your equipment by playing it at a safe level. One that lets the sound come through loud and clear without annoying blaring or distortion—and, most importantly, without affecting your sensitive hearing.

We recommend you to avoid prolonged exposure to excessive noise.

Sound can be deceiving. Over time your hearing "comfort level" adapts to higher volumes of sound. So what sounds "normal" can actually be loud and harmful to your hearing.

Guard against this by setting your equipment at a safe level **BEFORE** your hearing adapts.

To establish a safe level:

- Start your volume control at a low setting.
- Slowly increase the sound until you can hear it comfortably and clearly, and without distortion.

Once you have established a comfortable sound level:

- Set the dial and leave it there.

Taking a minute to do this now will help to prevent hearing damage or loss in the future. After all, we want you listening for a lifetime.

Battery installation

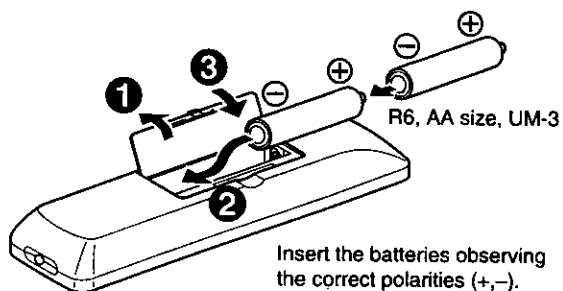

Insert the batteries observing the correct polarities (+,-).

Use of batteries

- Do not mix old and new batteries, or batteries of different types (manganese and alkaline, etc.).
- Never subject batteries to excessive heat or flame; do not attempt to disassemble them; and be sure they are not short-circuited.
- If the remote control is not to be used for a long period of time, remove the batteries and store them in a cool, dark place.
- Do not attempt to recharge alkaline or manganese batteries.
- Do not use rechargeable type batteries.

Battery life

The battery life is about one year.

The batteries should be replaced if commands from the remote control transmitter do not operate the unit even when the transmitter is held close to the front panel.

Correct method of use

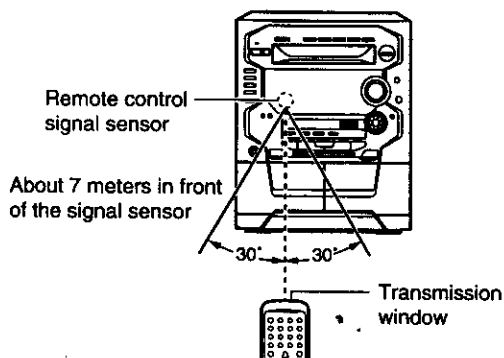

Operation notes

- Do not place obstacles between the remote control signal sensor and remote control unit.
- Do not expose the remote control signal sensor to direct sunlight or to the bright light of an inverter fluorescent light.
- Take care to keep the remote control signal sensor and end of the remote control unit free from dust.
- If this system is installed in a rack with glass doors, the glass doors' thickness or color might make it necessary to use the remote control a shorter distance from the system.

To prevent damage

- Never place heavy items on top of the unit.
- Do not disassemble or reconstruct the unit.
- Do not spill water or other liquids into the unit.

Placement of speakers

A Placement of front speakers

Place the speakers so that the superwoofer is on the outside.

Note

- Keep your speakers at least 10 mm ($13/32$ ") away from the system for proper ventilation.
- To avoid damage to the speakers, do not touch the speaker cones if you have taken the nets off.

B Placement of center/surround speakers

Center speaker

Place the center speaker above your TV, as close to it as possible.

Note

Do not place the center speaker on this unit as sound quality will be affected.

Surround speakers

As well as enjoying normal stereo reproduction with the left and right front speakers, surround speakers can also be connected to the system in order to enjoy a feeling of depth and movement of sound.

Place the speakers with the Panasonic logo facing toward the listening position.

We recommend that surround speakers be placed on the side of, or slightly behind, the listener at ear level.

However, the position should be adjusted to your personal preference, because the effect varies to some degree depending upon the type of music and the music source.

C Attaching to a wall

Set speaker onto screws and slide through bracket to lock into position.

Note

The wall or pillar on which the speaker systems are to be attached should be capable of supporting a weight of 5 kg.

Caution

- Use the speakers only with the recommended system. Failure to do so may lead to damage to the amplifier and/or the speakers, and may result in the risk of fire. Consult a qualified service person if damage has occurred or if you experience a sudden change in performance.
- Do not attempt to attach these speakers to walls using methods other than those described in this manual.



If irregular coloring occurs on your television

The front and center speakers are designed to be used close to a television, but the picture may be affected with some televisions and set-up combinations.

If this occurs, turn the television off for about 30 minutes.

The television's demagnetizing function should correct the problem. If it persists, move the speakers further away from the television.

Note

Surround speakers do not have magnetic shielding. Do not place them near televisions, personal computers or other devices easily influenced by magnetism.

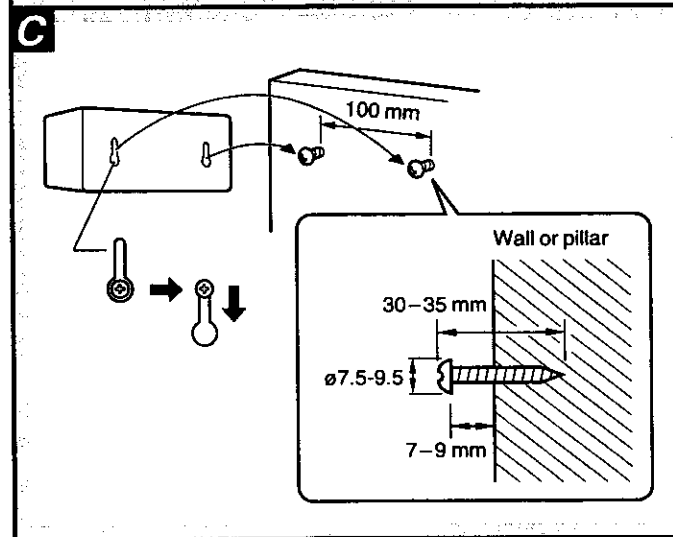
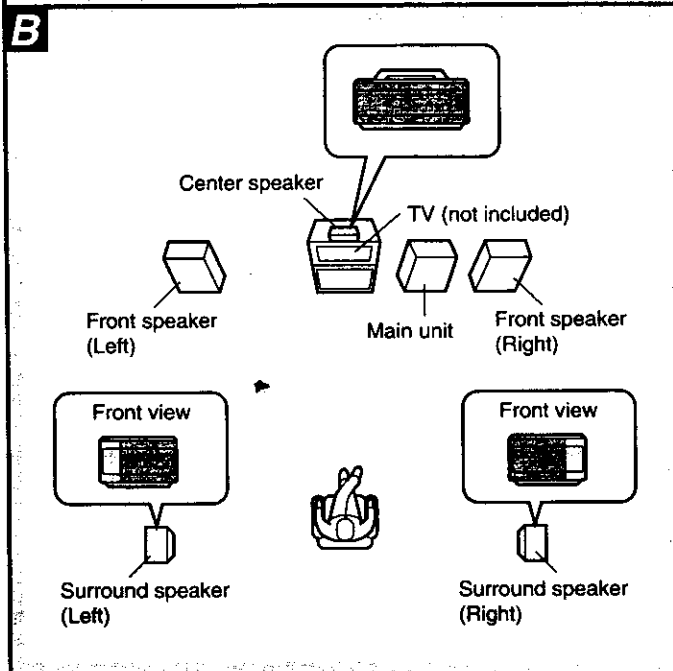
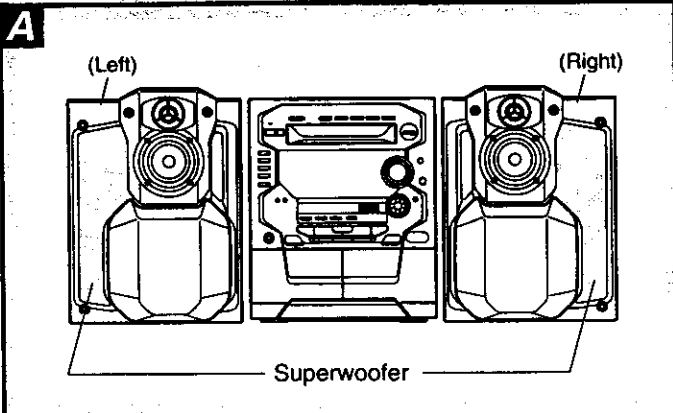

**Basic connections
(for supplied accessories)**

- Plug the AC power cord into a household AC outlet only after all other connections have been made.
- To prepare the antenna wires and speaker cords, twist the vinyl cover tip and pull off.

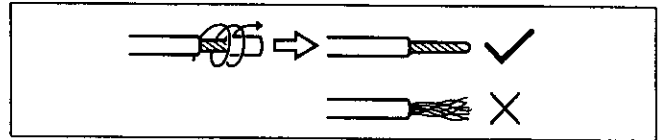

Before use

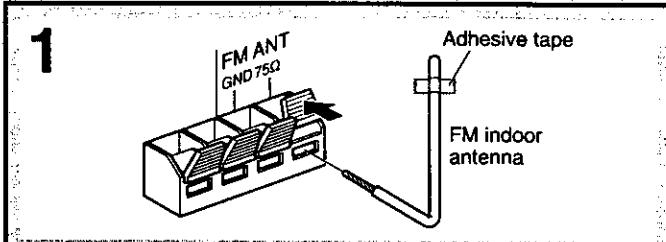
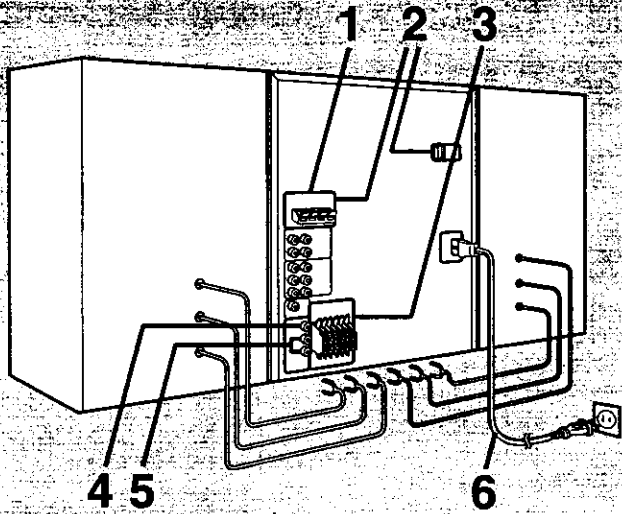

1. Connect the FM indoor antenna.

Tape the antenna to a wall or column, in a position where radio signals are received with the least amount of interference.

Note

For best reception:
An FM outdoor antenna is recommended. (→ page 8.)

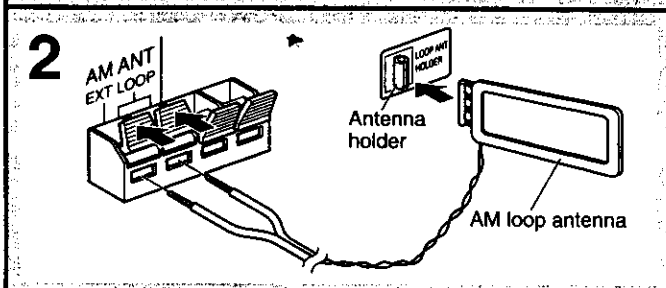

2. Connect the AM loop antenna.

After attaching the antenna, turn on the system and tune in a broadcast station. Then, turn the antenna to the angle of best reception and least interference.

3. Connect the front speakers.

Connect each end of the speaker cables to the terminal levers of the same color.

Use only the supplied front speakers.

The combination of the main unit and front speakers provide the best sound. Using other front speakers can damage the unit and sound quality will be negatively affected.

Caution

To prevent damage to circuitry, never short-circuit positive (+) and negative (-) speaker wires.

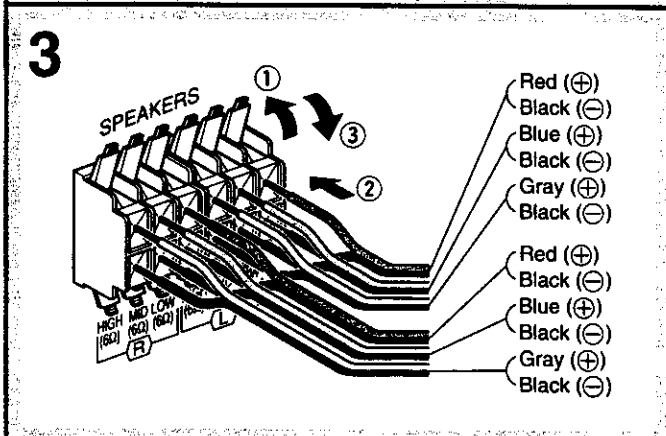

4. Connect the center speaker.

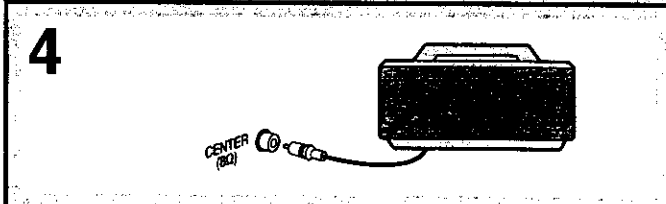

5. Connect the surround speakers.

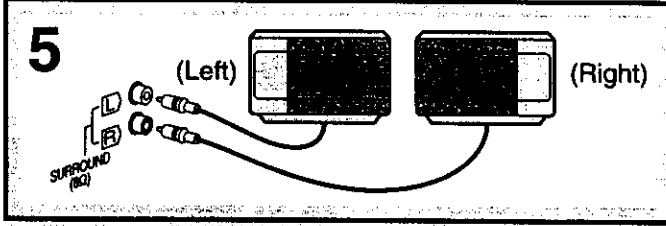

6. Connect the AC power cord.

Before use

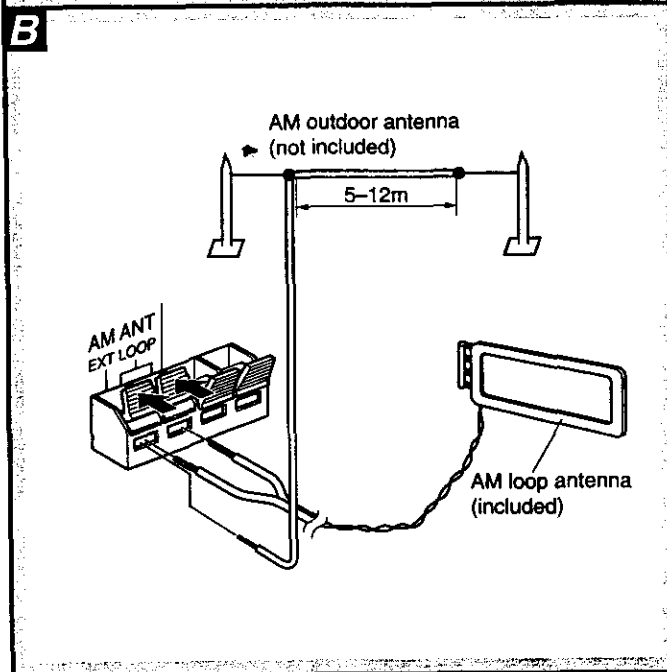
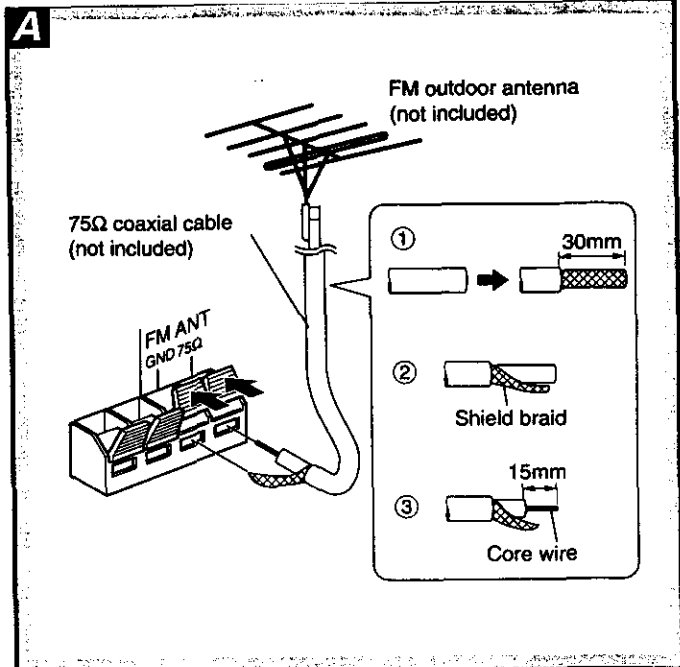

Optional antenna connections

You may need an outdoor antenna if you use this system in a mountainous region or inside a reinforced-concrete building, etc.

A FM outdoor antenna

Disconnect the FM indoor antenna if an FM outdoor antenna is installed.

- ① Remove a piece of the outer vinyl insulator.
- ② Twist the shield braid.
- ③ Expose the core wire.

Note

An outdoor antenna should be installed by a qualified technician only.

B AM outdoor antenna

Connect the outdoor antenna without removing the AM loop antenna. Run 5 to 12 m of vinyl-covered wire horizontally along a window or other convenient location.

Note

When the unit is not in use, disconnect the outdoor antenna to prevent possible damage that may be caused by lightning. Never use an outdoor antenna during an electrical storm.

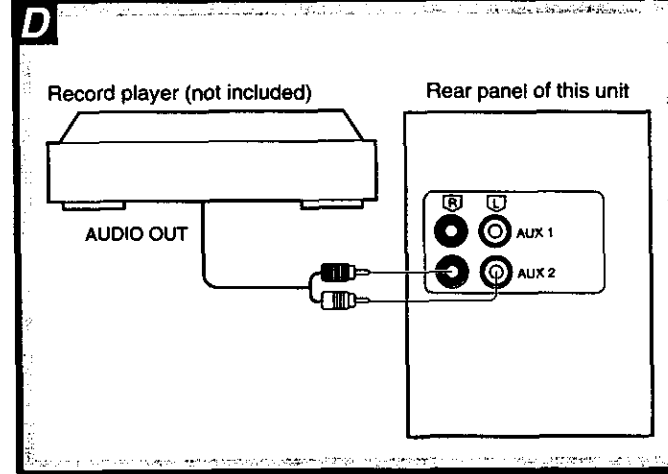
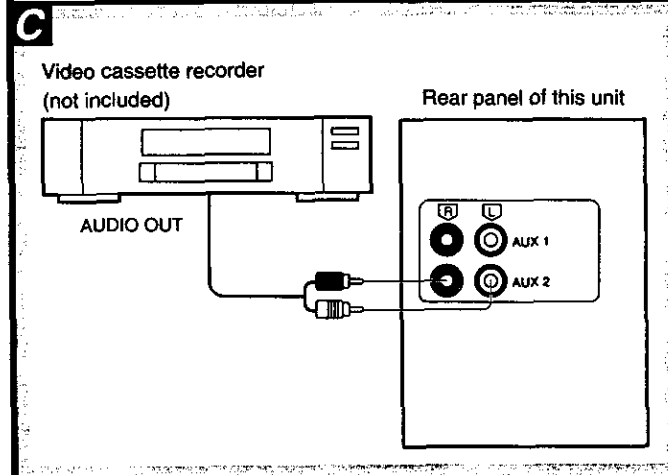
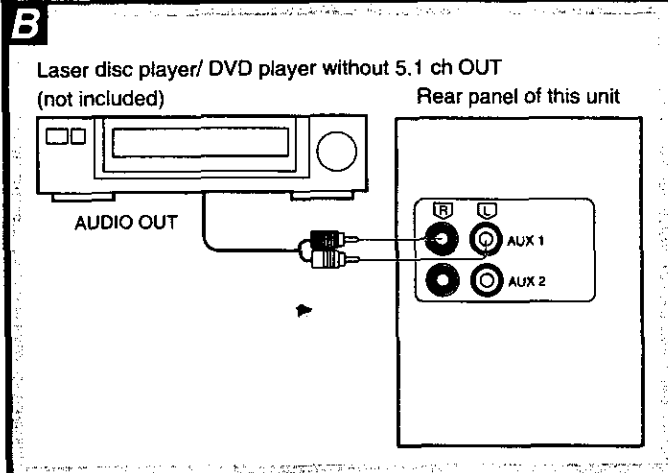
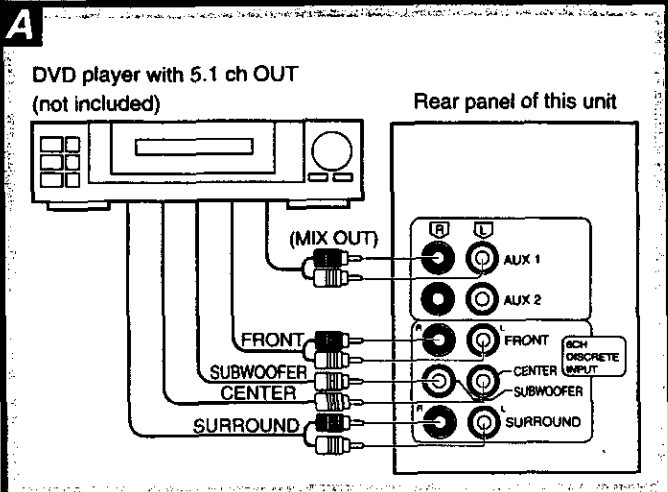

External unit connection

- For details, refer to the manual of the units which are to be connected.
- When units other than those described below are to be connected, please consult with your dealer.

A DVD player with 5.1 ch OUT

Sound cannot be produced unless an DOLBY DIGITAL decoder is connected.
A DVD player with a built-in DOLBY DIGITAL decoder is recommended.
This will allow you to enjoy the brilliant images and powerful sounds available on DVD software.

B Laser disc player/DVD player (without 5.1 ch OUT)

This unit has Dolby Pro Logic circuitry. If the audio output of video equipment is connected to the AUX1 or 2 terminal of this unit, the sound will be reproduced with the same powerful stereophonic effects found in movie theaters.

C Video cassette recorder

You can enjoy only sound of the video cassette recorder.

D Record player

Sound cannot be produced unless an phono equalizer (not included) is connected.
A record player with a built-in phono equalizer is recommended.

To improve the sound effect

The front speakers have built-in subwoofers, but it is possible to connect another subwoofer (not included) to the SUBWOOFER OUT terminal on the rear panel of this unit.

Before use

Before use

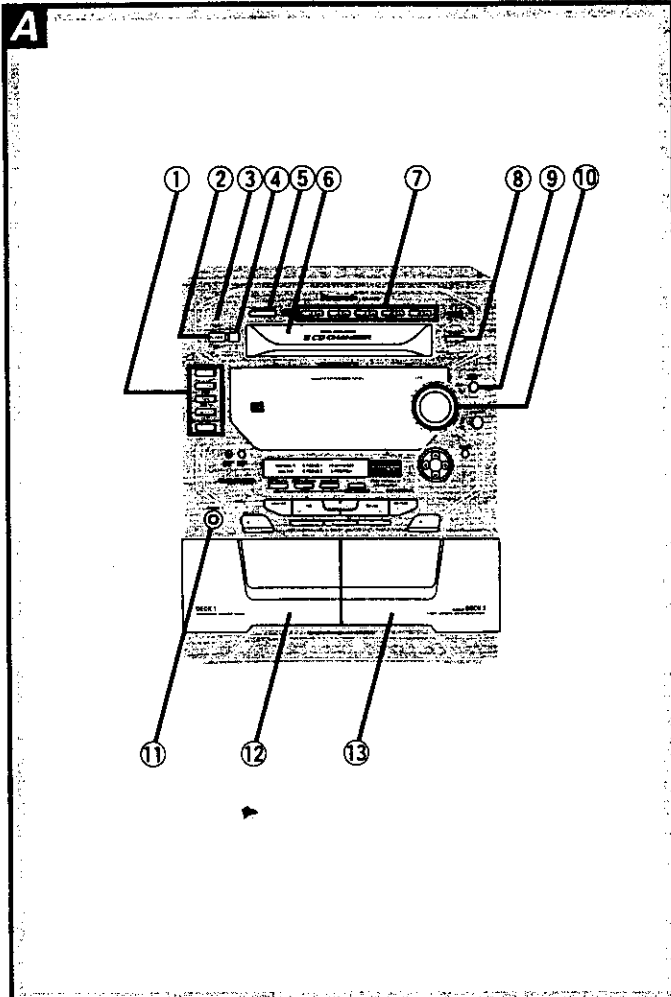

A Main unit

No.	Name	Ref. page
①	Input select buttons and indicators (CD, TUNER BAND, TAPE DECK 1/2, AUX 1/2, 6CH DISCRETE INPUT)	14, 17, 21, 40
②	Standby/on switch (⏻/⏻, POWER)	12
Press to switch the unit from on to standby mode or vice versa. In standby mode, the unit is still consuming a small amount of power.		
③	AC supply indicator (AC IN)	12
This indicator lights when the unit is connected to the AC mains supply.		
④	Eco mode button (MODE)	12
⑤	CD manager button (CD MANAGER)	20
⑥	Disc tray	16
⑦	Disc select, disc tray open/close buttons (CD1-CD5 CD DIRECT PLAY, ▲ OPEN)	16,17
⑧	Random play button (RANDOM)	18
⑨	Display select/demonstration button (-DISPLAY/-DEMO)	12, 40
⑩	Volume control (VOLUME)	15
⑪	Headphones jack (PHONES)	40
⑫	Deck 1 cassette holder	21
⑬	Deck 2 cassette holder	21

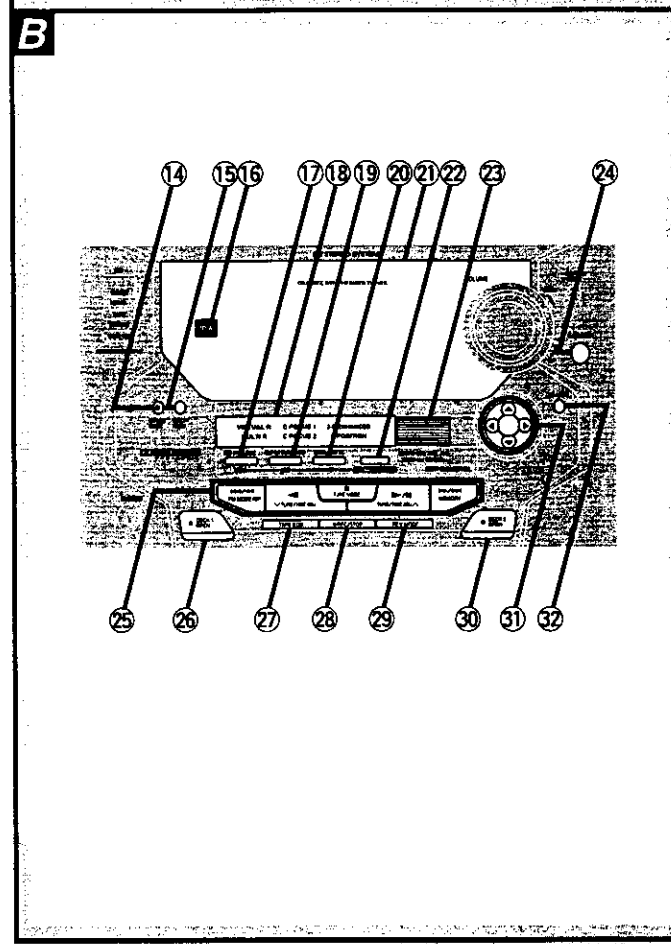

B Center console

⑭	Play timer/record timer button and indicator (⏻ PLAY/⏻ REC)	37, 38
⑮	Clock/timer button (CLOCK/TIMER)	13, 37, 38
⑯	3D AI lamp (3D AI)	
⑰	DOLBY PRO LOGIC on/off, Tri-amp control [LOW] button and indicator (⏻ PRO LOGIC, LOW)	33
⑱	AV effect indicators (VIRTUAL R, MULTI R, C.FOCUS 1, C.FOCUS 2, 3-D ENHANCED, S.POSITION)	35, 36
⑲	Super surround on/off, Tri-amp control [MID] button and indicator (SUPER SURROUND, MID)	34
⑳	Simulated stereo on/off, Tri-amp control [HIGH] button and indicator (SIMULATED ST, HIGH)	34
㉑	Display	
㉒	Tri-amp control on/off button and indicator (TRI-AMP CONTROL)	29
㉓	Jog control (SOUND CONTROL JOG, PUSH (AV EFFECT))	27
㉔	Super woofer on/off button and indicator (S.WOOFER)	27
㉕	Basic operating buttons	
Functions change according to the source.		
㉖	Deck1 open button (▲ DECK1 OPEN)	21
㉗	Tape edit button (TAPE EDIT)	26
㉘	Recording start/stop button (● REC/STOP)	23
㉙	Reverse mode select button (REV MODE)	21
㉚	Deck2 open button (▲ DECK2 OPEN)	21
㉛	Joy stick (◀, ▶, ▼, ▲)	28
㉜	3D AI EQ button (3D AI EQ)	29

Front panel controls

Remote control

Buttons such as ② function is exactly the same way as the buttons on the main unit.

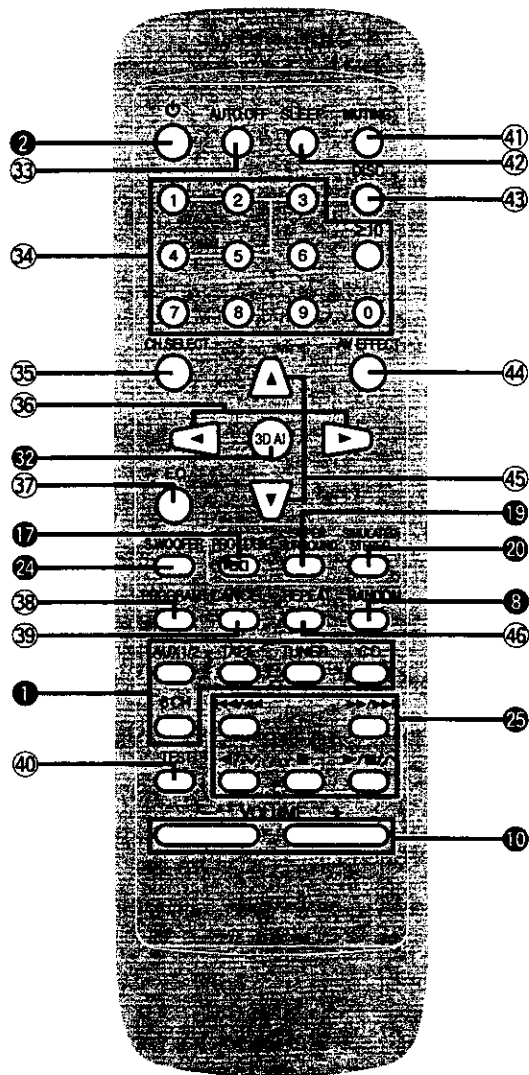

No.	Name	Ref. page
②	Standby/on button (⏻)	12
③③	Auto power-off (AUTO OFF)	13
③④	Numeric buttons (≥10, 1- 0)	18
③⑤	Channel select button (CH SELECT)	32
③⑥	Select buttons (◀ , ▶)	35
③②	3D AI select button (3D AI)	29
③⑦	EQ select button (EQ)	27
①⑦	DOLBY PRO LOGIC on/off button (□ □ PRO LOGIC)	33
②②	Super woofer on/off button (S.WOOFER)	27
③⑧	Program button (PROGRAM)	19
③⑨	Cancel button (CANCEL)	19
①	Input select buttons (CD, TUNER, TAPE, AUX1/2, 6CH)	14, 17, 21, 32, 40
④①	Test signal output button (TEST)	33
④①	Muting button (MUTING)	40
④②	Sleep button (SLEEP)	39
④③	Disc button (DISC)	18
④④	AV effect button (AV EFFECT)	35, 36
④⑤	Select button (▼ , ▲)	32
①⑨	Super surround on/off button (SUPER SURROUND)	34
②①	Simulated stereo on/off button (SIMULATED STEREO)	34
③	Random button (RANDOM)	18
④⑥	Repeat button (REPEAT)	18
②⑤	Reverse side playback button (◀ / √)	21
②⑤	Skip/search buttons (◀ ◀ / ▶▶ , ▶▶ / ▶▶)	17, 22
②⑤	Play/pause button (▶ / II / ^)	17, 21
②⑤	Stop button (■)	17, 21
①⑩	Volume buttons (- VOLUME +)	15

Before use

A

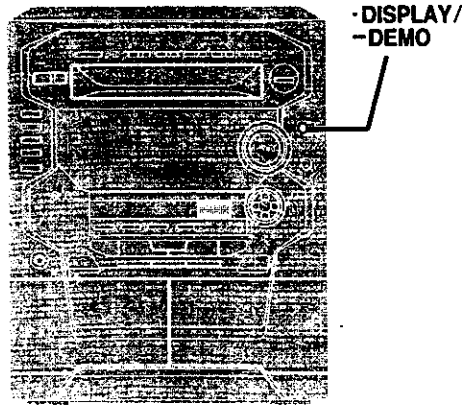

A Turning the demo function on (DEMO)

If the clock has not been set, a demonstration of the display is shown when the unit is off.
This function is set to on at the time of purchase.

To get the most from the economy mode (see below), turn the demo function off.

Press and hold [-DISPLAY/-DEMO] until "NO DEMO" is displayed.

Every time you press and hold the button;

NO DEMO (off) ↔ DEMO (on)



B

Economy mode (MODE)

When this mode is used the power consumed when the unit is switched to standby mode reduces from a maximum of 13.5 W to 0.25 W.
This mode is set to on at the time of purchase.

	NORMAL	ECO(on)
Display	Clock display, etc.	Blank
Power consumption in standby mode	13.5 W	0.25 W

B

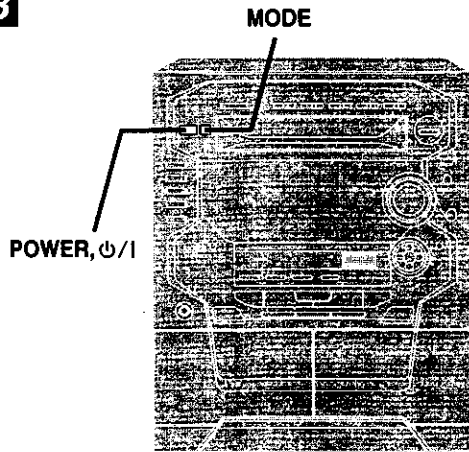

The demonstration is shown if DEMO is on, regardless of the condition of the ECO mode. Turn DEMO off if ECO is used.

Turning ECO on and off:

**Press [POWER] to turn the unit on.
Press [MODE].**

The display changes each time the button is pressed:
NORMAL (off) ↔ ECO (on)

When ECO is on:

When the unit is turned off, the display panel remains blank but the AC IN indicator stays to show the unit is still connected to the AC power output.

Conserving power

The unit consumes 0.25 W even when it is turned off with [⏻/⏻ , POWER] or Auto-off function and ECO mode is turned on. To save power when the unit is not to be used for a long time, unplug it from the household AC outlet. Remember to reset the radio stations and any other memory items before using the unit again.

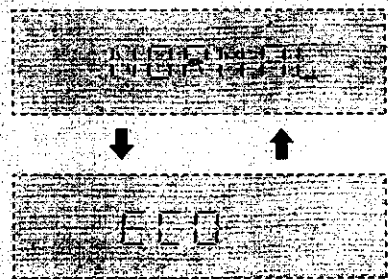
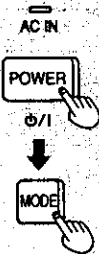

Note

When the unit is off, the mode can be switched from NORMAL to ECO, but not the other way.

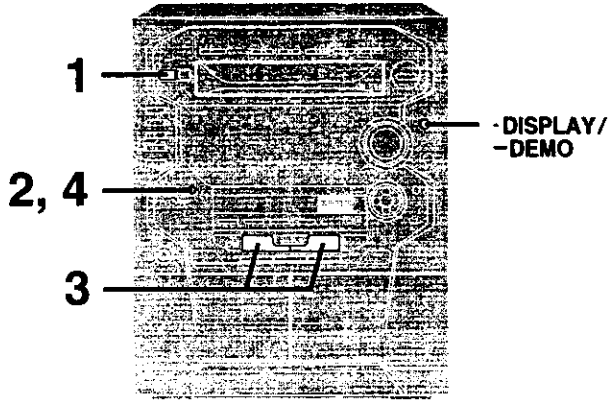
A**A** **Setting the time**

The example in the figure shows how to set the time for 4:25 p.m.

1. Press [POWER] to turn the unit on.
2. Press [CLOCK/TIMER] to select "CLOCK".
Every time you press the button;
CLOCK → @PLAY → @REC → Previous display
3. (Within 5 seconds or so)
Press [TUNE/TIME ADJ (∨ or ∧)] to set the present time.
4. Press [CLOCK/TIMER] to finish setting the time.

The display will return to whatever was displayed before you set the time.

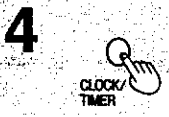
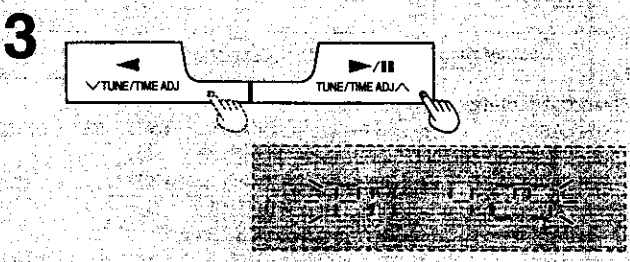
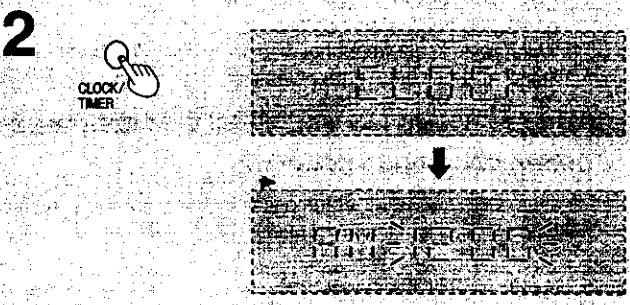
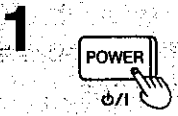
Preparations
**Displaying the clock****When the unit is off.**

When ECO mode is off;
The clock is displayed constantly.
When ECO mode is on;
Press [-DISPLAY/-DEMO].
The clock is displayed for about 5 seconds and then the display goes blank again.

When the unit is on

Press [CLOCK/TIMER] so "CLOCK" is shown.
The clock is shown for about 5 seconds then the previous display is restored.

B **Auto power-off****by remote control only**

When CD or tape is selected as the source.
To save power, the unit turns off if it is left unused for four minutes.

This function does not work if the source is tuner, AUX 1, AUX 2 or 6CH DISCRETE INPUT.

Press [AUTO OFF].

"AUTO OFF" is displayed.

To cancel
Press [AUTO OFF] again.

For your reference

The setting is maintained even if the unit is turned off. When the unit is turned on again, the unit functions as described above.
If you select tuner, AUX 1, AUX 2 or 6CH DISCRETE INPUT as the source, "AUTO OFF" goes out. It comes on again when you select CD or tape.

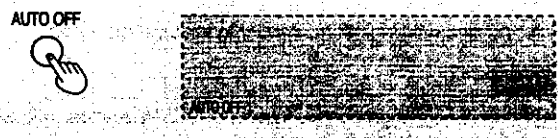
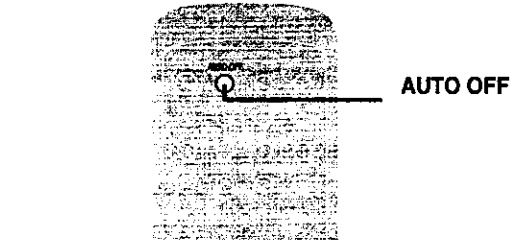
B

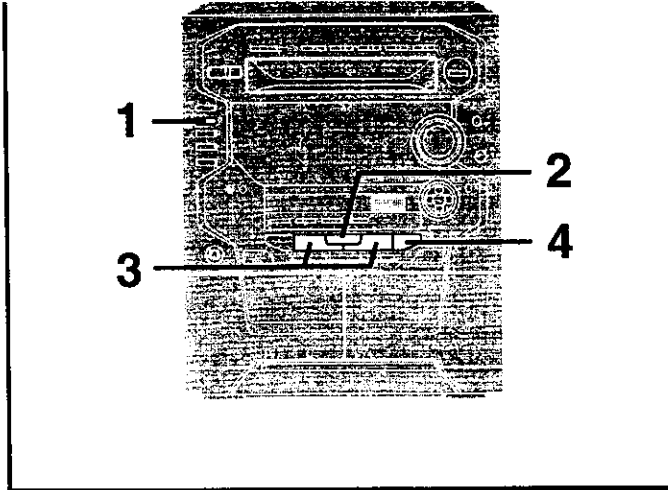

1

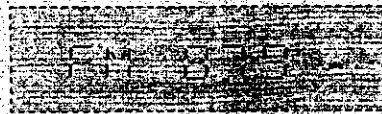

2



3



4

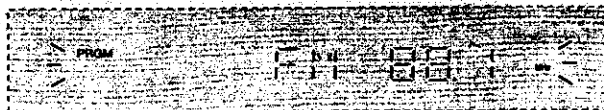

Preset channel

- Up to 12 stations can be set in each band with automatic or manual memory presetting.
- If broadcast frequencies are preset in the memory, you can easily tune in any of these frequencies from the system or remote control unit.
- You can preset just those stations you like. (See "Presetting only your favorite stations" below.)

1. Press [TUNER/BAND] to select band.

The power will come on automatically.
Every time you press the button; "FM" → "AM".

2. Press [■, TUNE MODE] to select "MANUAL".

Every time you press the button; "MANUAL" → "PRESET".

3. Press [TUNE/TIME ADJ (∨ or ∧)] until the display shows the frequency from which you want to begin automatic memory presetting.

Tips on tuning in radio stations

- ① Hold down either [TUNE/TIME ADJ (∨ or ∧)] until the frequency numbers start scrolling.
- ② When near to the frequency you are looking for, press [TUNE/TIME ADJ (∨ or ∧)] repeatedly until the station is tuned in.

4. Press and hold [▶▶/▶▶, MEMORY] until the frequency begins to change.

This will start presetting automatically. When finished, the radio will tune in the last station memorized.

If auto presetting is not possible because radio signals are weak or for some other reason, do the following.

Presetting only your favorite stations

Preset the stations one at a time.

1. Perform step 1 above. Then, press [▶▶/▶▶, MEMORY] ("PRGM" flashes) and select a station with [TUNE/TIME ADJ (∨ or ∧)].
2. While "PRGM" is flashing press [▶▶/▶▶, MEMORY] again and select a preset channel with [TUNE/TIME ADJ (∨ or ∧)].
3. Press [▶▶/▶▶, MEMORY] to preset the station.

Memory retention

The preset stations are retained in memory for about 2 weeks even if the system is unplugged.

FM allocation settings:

This system comes equipped with an electronic digital tuner that divides the broadcast band into many small steps. These steps match the assignable broadcast frequencies and intervals in between.

Each country allocates broadcast bands according to their particular needs.

By adjusting the allocation, you can enable the tuner to receive FM broadcasts allocated in 0.1 MHz steps. Press and hold [TUNER/BAND]. After a few seconds the display will change to a flashing display of the current minimum frequency. If you continue to hold [TUNER/BAND] down, the minimum frequency will change. Release the button at this time.

To return to the original frequency indication, repeat above.

Note

After changing the allocation setting, the frequencies you previously preset in the memory will be cleared.

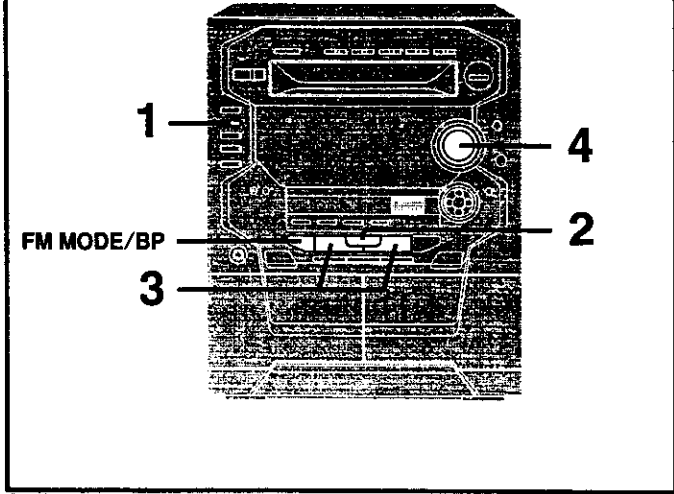

1. Press [TUNER/BAND] to select band.

The unit comes on and the radio begins to play.
Every time you press the button; "FM" ↔ "AM".

2. Press [■, TUNE MODE] to select "PRESET" or "MANUAL".

Every time you press the button; "MANUAL" ↔ "PRESET".
PRESET: For preset stations
MANUAL: For non-preset stations

3. Press [TUNE/TIME ADJ (∨ or ∧)] to select the desired broadcast.

"ST" lights when an FM stereo broadcast is being received.
"TUNED" lights when you precisely tune in a broadcast station.

4. Turn [VOLUME] to adjust the volume level.

Auto tuning

Auto tuning is an easy way to tune in non-preset stations in the manual mode.

Hold down [TUNE/TIME ADJ (∨ or ∧)], and release the button when the frequency starts scrolling.

The radio will stop automatically on the first station it picks up.

- When there is outside interference, the radio sometimes stops on a certain frequency where no station is broadcasting.

To stop auto tuning

Press [TUNE/TIME ADJ (∨ or ∧)] again.

A If noise is excessive in the FM stereo mode

Press [⏪/⏩, FM MODE/BP]. ("MONO" will light up.)

Sound will be produced in monaural, but this also reduces noise.

Press the button again to cancel. "MONO" will go out.

Normally, you'll want to listen in stereo, so leave "MONO" off. This way, you can listen to stereo broadcasts in stereo, and monaural broadcasts in mono.

You can preset an FM station in monaural by following the steps under "Presetting only your favorite stations" on page 14. After selecting the station in step 1, select "MONO" with [⏪/⏩, FM MODE/BP], then continue with steps 2 and 3.

Note

- If you preset stations in memory they can be easily selected from the remote control with [◀/√], [▶/■/∧] or the numeric buttons.

1. Press [TUNER] to select band on the remote control.
2. Press [◀/√] or [▶/■/∧] to select the channel, or select the required channel directly with the numeric buttons.

To select a two-digit channel:

Press [≥10] and then the two numbers you want within 10 seconds or so.

- Sound is momentarily interrupted if you load/unload tapes while listening to an AM broadcast.

Radio operation

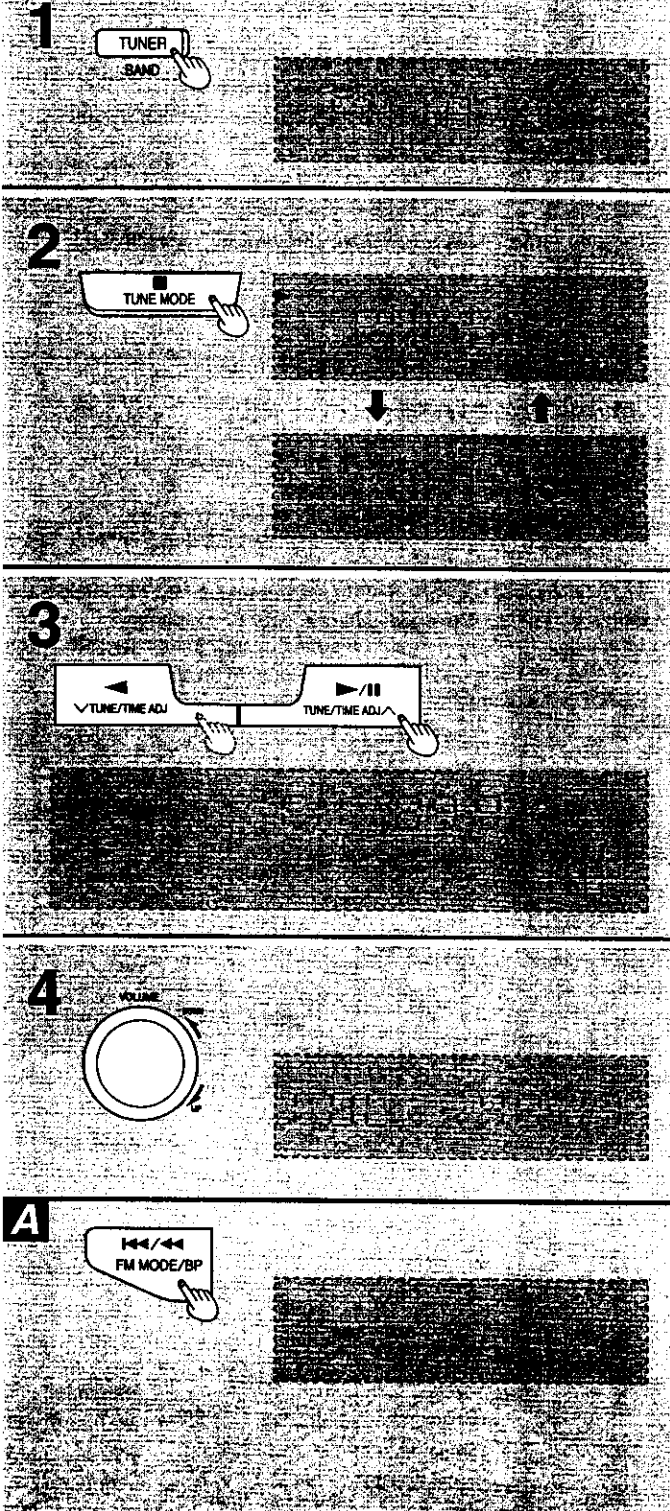

1, 3

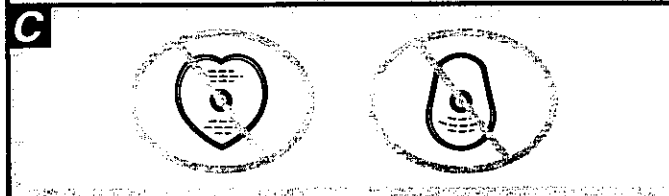
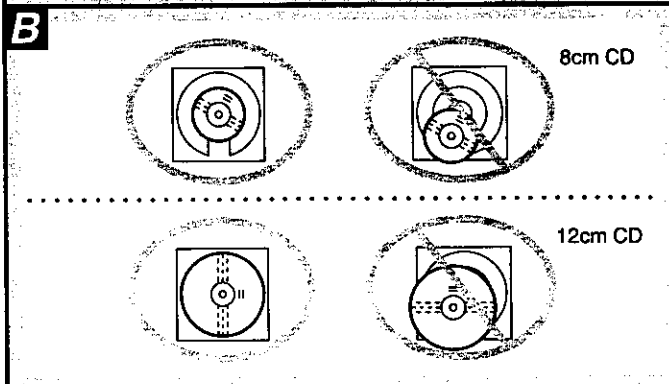
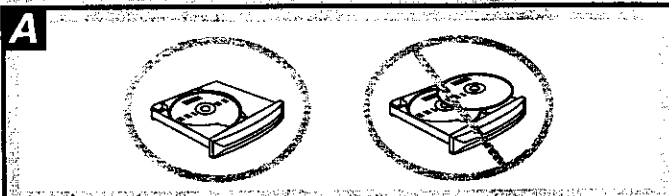
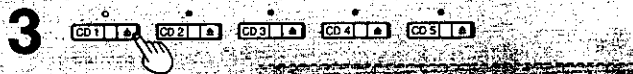
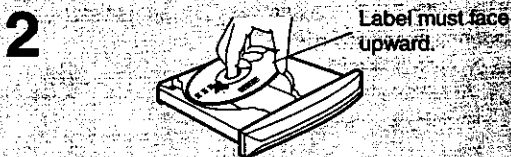
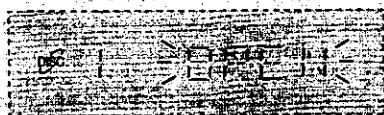
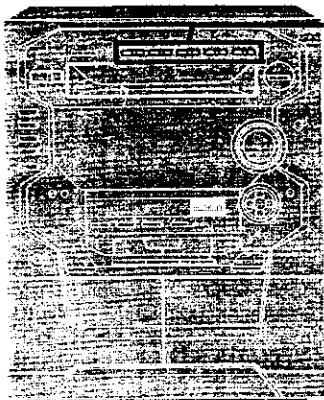

Loading and checking CDs

Always stop the changer before loading or changing CDs. You cannot change CDs while a disc is playing.

How to load CDs

1. Press the [▲] button.

The selected tray will open.

2. Set CD in the tray.

3. Press the same [▲] button.

The tray will close and the disc No., number of tracks and total playing time will be shown on the display.

To continue loading CDs in the other trays

Press another [▲] button to open the required tray.

The current tray closes and the selected tray automatically opens.

Disc Indicators (CD1 – CD 5)

The disc indicators light whenever the tray is in the playing position, whether it is loaded or not.

To prevent damage

Always observe the following points.

- **A** Load only 1 CD per tray.
- **B** Load CDs as shown in figure.
- An adapter is not needed with 8 cm CDs (singles).
- Set the system on a flat, level surface.
- Do not set it on top of magazines, inclined surfaces, etc.
- Do not move the system while trays are opening/closing, or when loaded.
- Do not put anything except CDs in trays.
- Do not use cleaning CDs or CDs which are badly warped or cracked.
- Do not use CDs with poorly attached labels or stickers. Adhesive protruding from underneath stickers or left over from peeled off stickers can cause your stereo to malfunction.
- **C** Do not use irregular shape CDs.

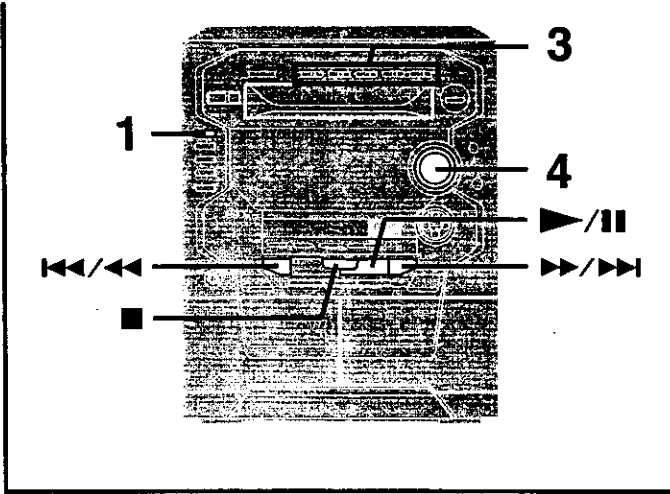

Sequential play

1. Press [CD].
The power will come on automatically.
If the unit was off and a CD was loaded, play will start automatically (One touch play function).
2. Insert CDs in the trays.
(⇒ page 16.)
3. Press [CD 1] – [CD 5] to select the disc you want.
(If the desired CD is indicated on the display panel the same operation can be accomplished by pressing [▶/⏸].)
Play will start from the first track on the selected disc, and will continue until the last track of the final disc is played (see below).
4. Turn [VOLUME] to adjust the volume level.

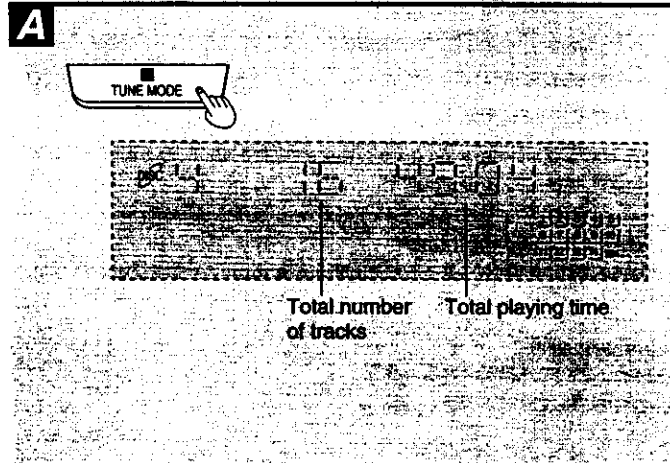
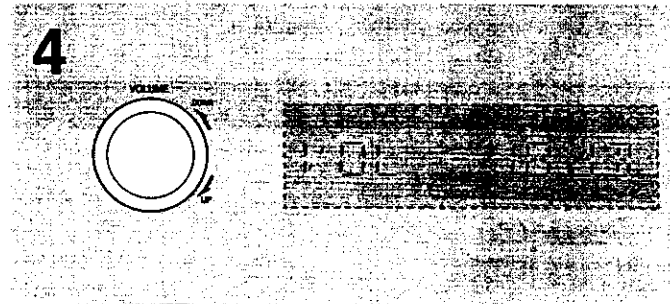
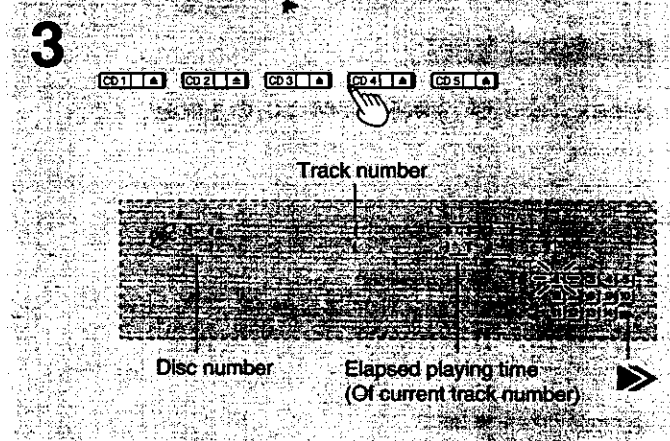
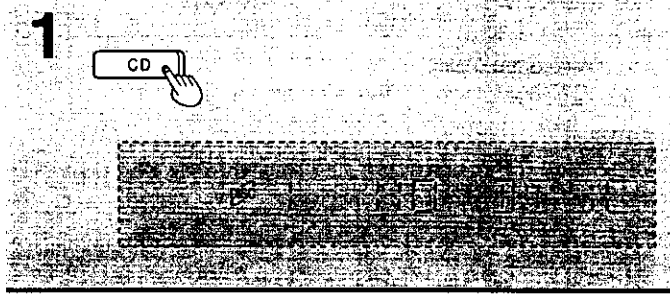

A To stop the disc
Press [■].

When "▶" appears on the display
It indicates there are 15 or more tracks on the disc in the playing position.

What is meant by "final disc"?
For example, if play starts from CD 4, CD 3 will be the "final disc".
Order of progression:
CD 4 → 5 → 1 → 2 → 3

To pause	Press [▶/⏸] during playback. To resume playback, press [▶/⏸].
To search forward/backward (Search)	Hold down [◀/◀◀] (backward) or [▶/▶▶] (forward) during playback or pause mode.
To skip forward/backward	Press [◀/◀◀] (backward) or [▶/▶▶] (forward) during playback or pause mode. Each press increases the number of skips. Current position 2 press 1 press 1 press 2 press track track track

- Note**
- During random play (⇒ page 18), you cannot skip to tracks which have already been played.
 - During program play (⇒ page 19) or random play, you can search forward or backward only within the current track.
 - During program play, skipping is always in the programmed order, whether forward or backward.

Reference:
• Use the CD manager function if you want to listen to one CD only. (⇒ page 20)

CD operation

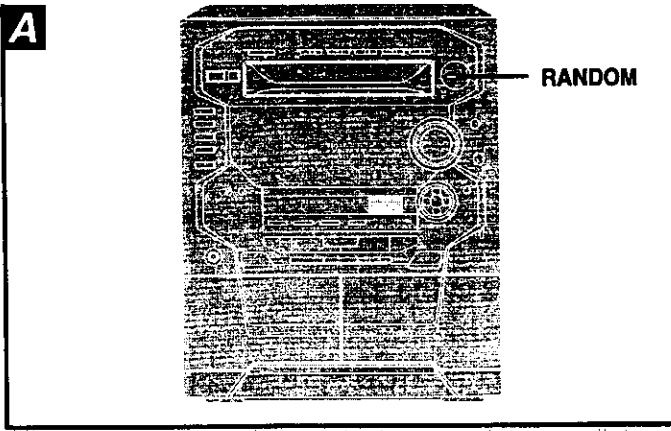

A Random play

Press [RANDOM].

Every time you press the button:

- 1- DISC → ALL DISC → Previous display

To random play just one disc

Select the CD you want to random play with [CD1]-[CD5] and press [RANDOM] to select "1-DISC".

To random play all the loaded CDs

Press [RANDOM] to select "ALL-DISC".

All tracks on the CD(s) will be played in random order. Playback will stop automatically when all tracks have been played.

To cancel random play

Press [RANDOM] to clear "RANDOM" display.

Note

You can use random play with your program. Only the programmed tracks will be played, but in random order.

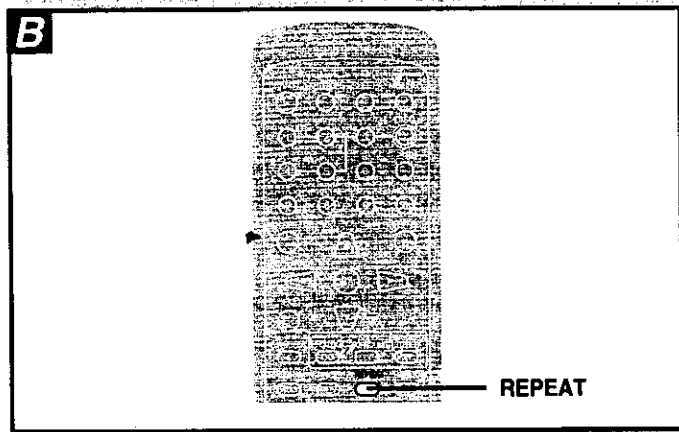
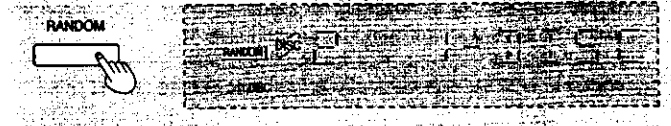

B Repeat play

by remote control only

Press [REPEAT] before or during play.

All tracks on the loaded CDs are repeated.

To cancel repeat play

Press [REPEAT] once again.

To repeat your favorite tracks

1. Program the tracks you want (⇒ page 19).
2. Press [REPEAT] and make sure "C" is displayed.
3. Press [▶/⏪/⏩]. Playback will start.

To repeat just one track

Set the 1-TRACK mode (⇒ page 20), press [REPEAT] before or during playback, and make sure "C" is displayed.

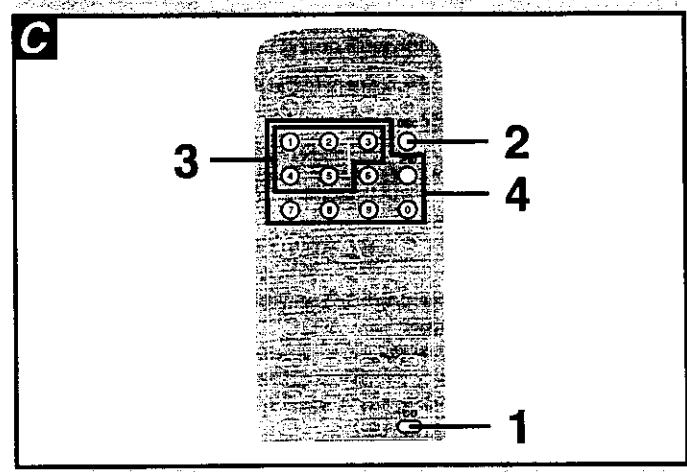

C Direct access play

by remote control only

1. Press [CD].

2. Press [DISC].

3. (Within 10 seconds or so)

Press [1] - [5] to select the disc you want.

4. Press the numeric button to select the desired track number.

The CD will be played from the selected track to the last track of the final disc. (⇒ page 17)

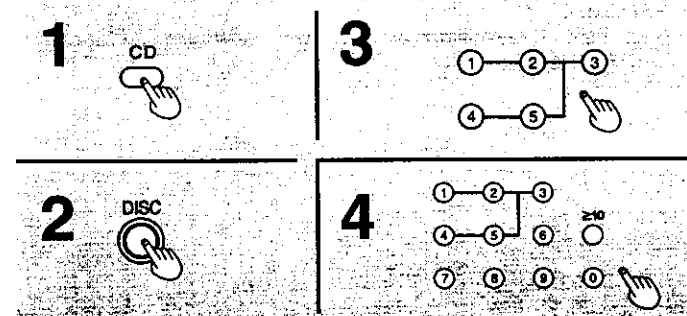

To select a two-digit track

Press [≥10] and then the two numbers you want within 10 seconds or so.

For example

- Track no. 20: [≥10] → [2] → [0]
- Track no. 35: [≥10] → [3] → [5]

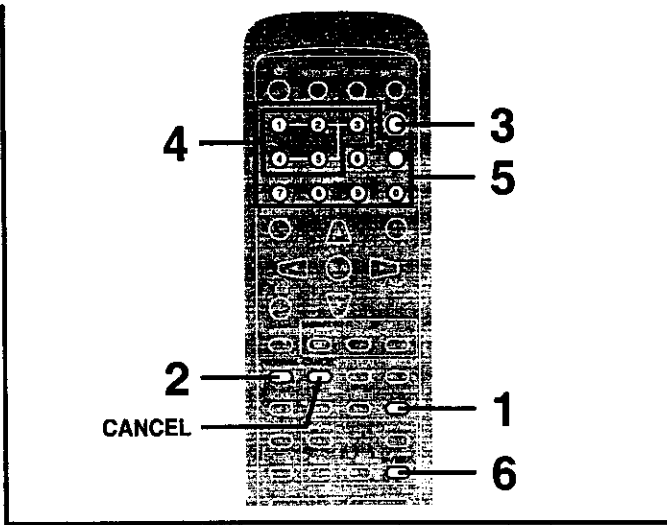

Program play

by remote control only

You can program up to 24 tracks.

1. Press [CD].
Ensure CD is stopped.
2. Press [PROGRAM].
3. Press [DISC].
4. (Within 10 seconds or so)
Press [1] – [5] to select the disc you want.
5. Press the numeric button to select the desired track.
Repeat steps 3 – 5 until you have programmed the desired track(s).
6. Press [▶/||/∧].
Play will start in the programmed sequence.

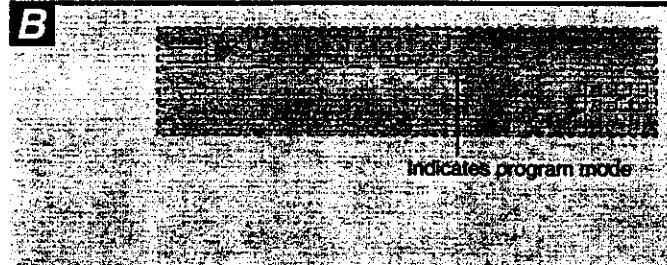
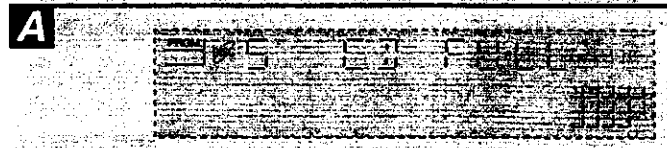
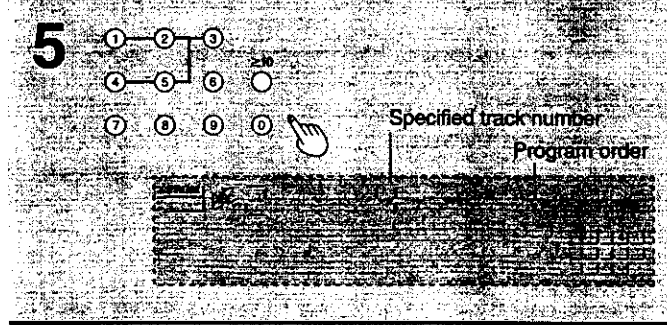
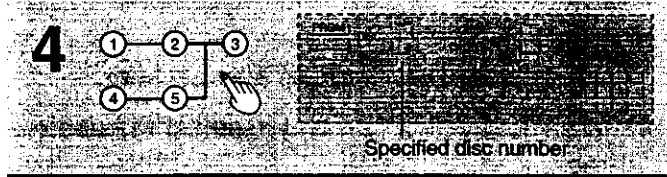
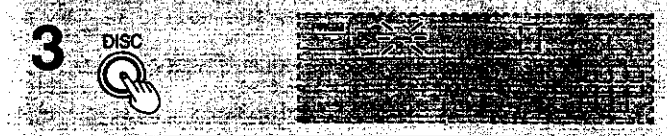
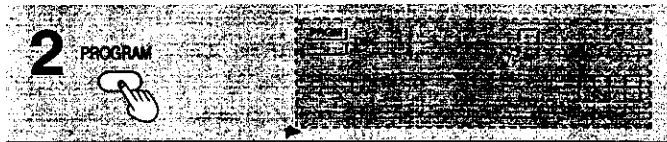

To cancel program play mode
Press [PROGRAM] in the stop mode.
Programmed contents will be saved in memory.
Pressing [■] will cancel program play, but it will also erase the entire program.

To select a two-digit track
Press [≥10] and then the two numbers you want.

A When "CD FULL" appears
The number of programmed tracks is limited to 24. No further tracks can be programmed.

- B** You can do the following during program mode
- Check program contents.
Press [◀◀/▶▶] or [▶▶/▶▶].
Every time you press one of the buttons, the track and program No. are shown on the display.
 - Add to the program.
Repeat steps 3 through 5.
 - Cancel entries.

From the last programmed track	Press [CANCEL].
A specified track only	Select the track with [◀◀/▶▶] or [▶▶/▶▶], and press [CANCEL] within 3 seconds.
All tracks	Press [■].

Memory retention
Your program is retained in memory for about 2 weeks while the system is unplugged.

To replay your program
If you turned off your program with [PROGRAM], you can play it again as explained below.
1. Press [PROGRAM].
2. Press [▶/||/∧].

If you program a track number not on your CDs
The track is initially programmed, but during program play, the player will skip that track and will continue playing from the next programmed item.

CD operation

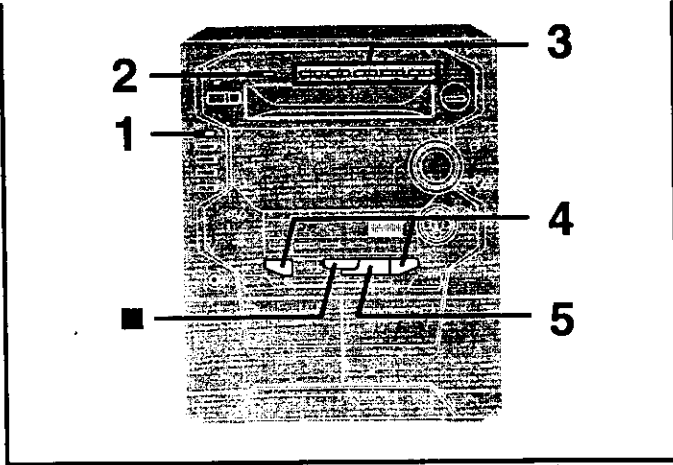

CD operation

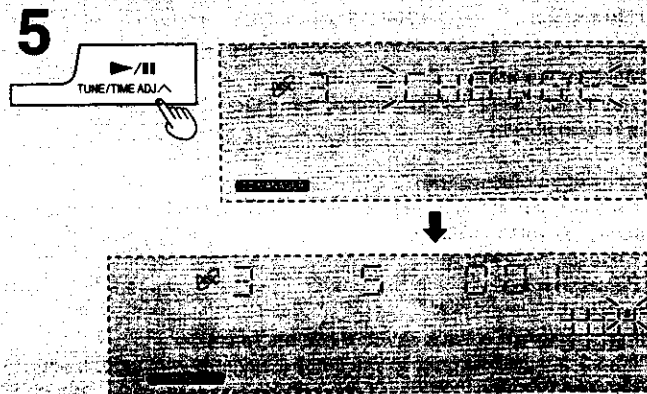
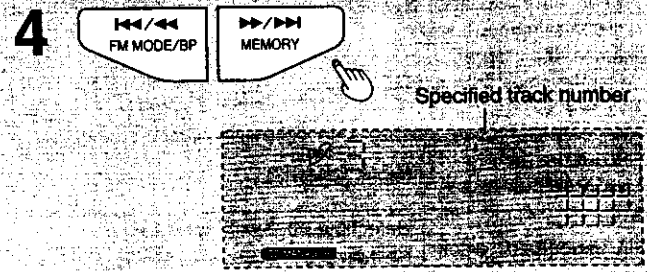
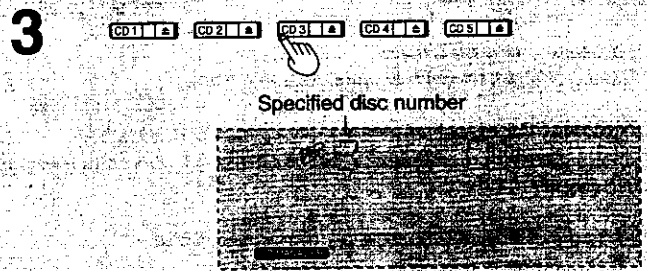
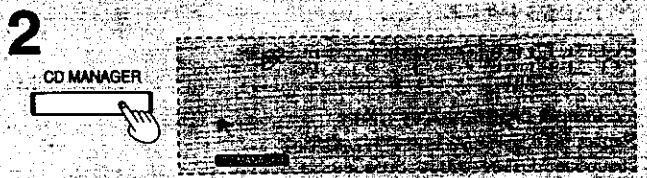
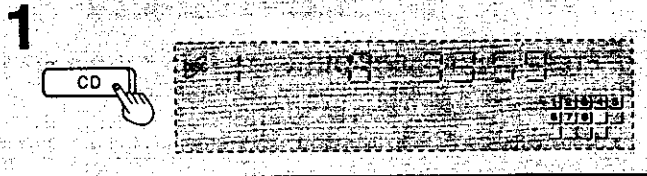

To listen to special CDs and tracks (CD Manager function)

This function makes it easier for you to select specific CDs and tracks from amongst those loaded in the player.

You can use this function to make recordings as well.

- There are 3 CD/track selection modes.
- For playing back 1 track only from all loaded CDs
1-Track mode (1-TRACK)
 - For playing back 1 CD only from all loaded CDs
1-Disc mode (1-DISC)
 - For playing back 1 track on all loaded CDs
1-Track All-Disc mode (1-ALL)

1. Press [CD].

Ensure CD is stopped.

2. Press [CD MANAGER] to select the desired mode.

Every time you press the button;

1-TRACK → 1-DISC → 1-ALL → NORMAL (OFF)

- 1-TRACK: Only one particular track is played.
 - 1-DISC: The tracks on only one particular disc are played.
 - 1-ALL: The same track numbers on each of the CDs are played in succession.
- (NORMAL: The original display is restored in about 3 seconds.)

3. Press [CD 1] – [CD 5] to select the disc you want.

Note

This step is not required if 1-ALL was selected in step 2.

4. Press [<<</>>>] or [>>>/<<<] to select the desired track.

Note

This step is not required if 1-DISC was selected in step 2.

5. Press [>>/||].

The selected track will start.

To stop play

Press [■].

When playback ends

"NORMAL" will appear on the display for about 3 seconds, then the CD MANAGER function will turn off automatically.

During play in the 1-ALL mode:

- It is not possible to skip back to a CD whose track has already been played.
- If a CD does not have the designated track number, it is skipped and play continues.

Notes

- You can use the CD Manager function together with repeat play.
- CD Manager function will be cancelled when you press the [RANDOM] button.

Listening to tapes

Types of tapes which can be played correctly:
The unit automatically identifies the type of tape.

NORMAL POSITION / TYPE I	✓
HIGH POSITION / TYPE II	✓
METAL POSITION / TYPE IV	✓

You can use either deck 1 or deck 2 for tape playback.

1. Press [TAPE DECK 1/2].

The power will come on automatically.

If the unit was off and a cassette was loaded, play will start automatically (One touch play function).

2. Press [▲ DECK1 OPEN] or [▲ DECK2 OPEN] and insert the tape.

Insert the tape with the exposed tape facing down.
Close the holder by hand.

3. Press [REV MODE] to select the reverse mode.

Every time you press the button;



- ⇄ : One side is played, then playback stops automatically.
- ⇄⇄ : Both sides (front side → reverse side) are played one time each, then playback stops automatically.
- ⇄⇄⇄ : Both sides are played 8 times each, then playback stops automatically.

4. Press [◀] or [▶/II] to start playback.

- [▶/II]: The forward side (front side) will play.
- [◀]: The reverse side will play.

5. Turn [VOLUME] to adjust the volume level.

To stop tape playback

Press [■].

A To change the deck to be used

Press [TAPE DECK 1/2] to select the deck you want to use when you load cassettes into both decks.

To listen to 2 tapes consecutively

Load a tape into each deck and select (⇄⇄). Both tapes will be played 8 times each.

Note

Playback is interrupted while playing back tapes if you open the other deck.

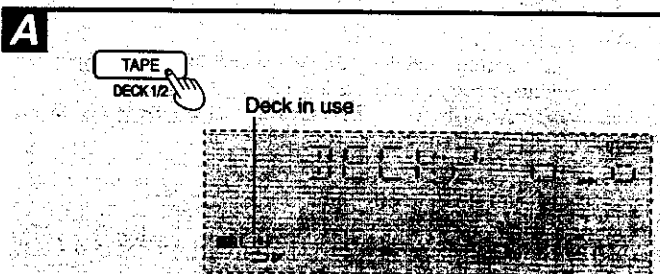
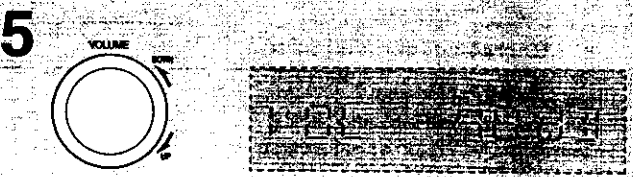
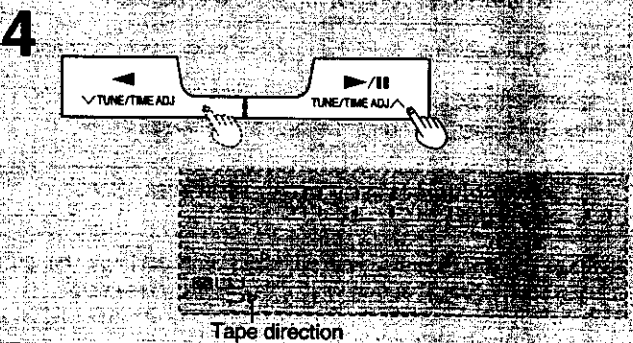
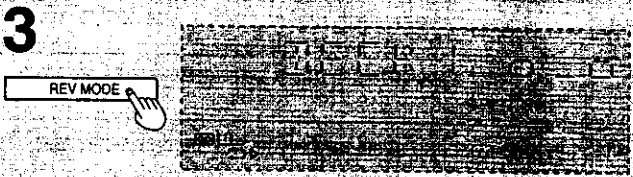
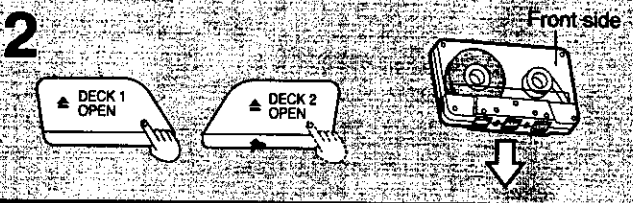
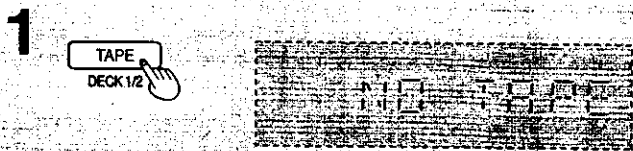
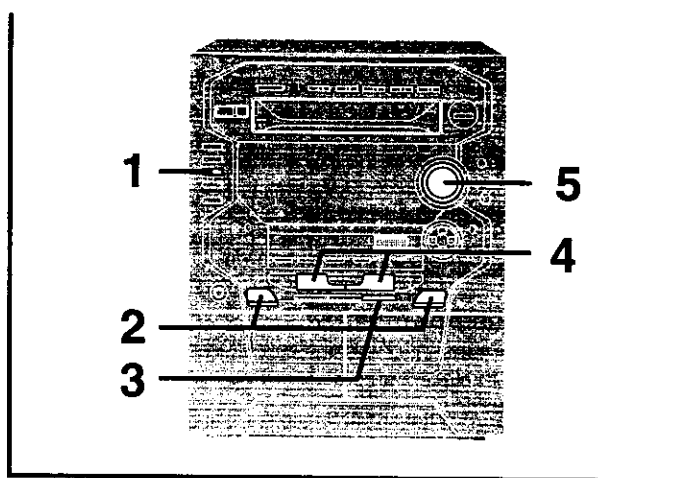

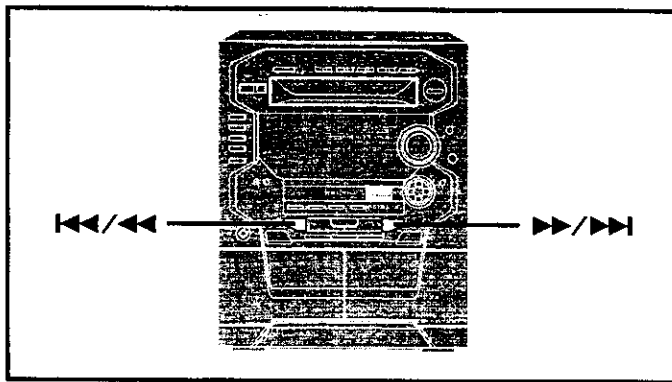

To fast-forward or rewind the tape

Press [<<</>>>] or [>>>/<<<] in the stop mode.

Tape direction	To rewind	To fast-forward
" ▶ "	[<<</>>>]	[>>>/<<<]
" ◀ "	[>>>/<<<]	[<<</>>>]

To find the beginning of a program (TPS: Tape Program Sensor)

TPS finds the beginning of a track and resumes play from there. Each press increases the number of tracks skipped, up to a maximum of 9.

Press [<<</>>>] or [>>>/<<<] during play.

Tape direction	To play the current tune from the beginning	To play the next tune from the beginning
" ▶ "	[<<</>>>]	[>>>/<<<]
" ◀ "	[>>>/<<<]	[<<</>>>]

Note

The TPS function searches for silent parts of about 4 seconds in length which are normally found between tunes. As a result, it may not function properly in the following cases:

- With short silent parts
- When noise occurs between tunes
- With silent parts found within tunes

Types of tapes which can record correctly

The unit automatically identifies the type of tape.

NORMAL POSITION / TYPE I	✓
HIGH POSITION / TYPE II	✓
METAL POSITION / TYPE IV	✗

This system cannot make a recording, or erase correctly, if metal position tapes are used.

To record from the beginning of the tape

You cannot record on the leader part of the tape. Before recording, wind the tape past the leader to a point where recording can start immediately.

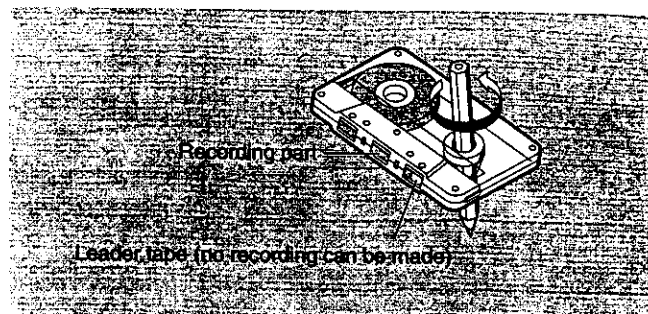

To start recording from a particular position on the tape

Wind the tape on to the position you want recording to start from.

To start recording from the reverse side

Insert the cassette into deck 2 and follow these steps to change the side.

1. Press [TAPE DECK 1/2] so the deck 2 indicator lights.
2. Press [◀] then [■]. Tape direction will be shown as "◀".

How volume, sound quality/surround effect recording

The tape you are recording is not affected whatsoever by changes in volume, sound quality, surround effect and surround system. In recording, sound quality, surround effect and surround system are set automatically to "FLAT".

To erase a recorded sound

1. Press [TAPE DECK 1/2].
2. Insert the recorded tape into deck 2.
3. Press [REV MODE] to select reverse mode.
4. Press [● REC/STOP].

Note

- You cannot record when [6CH DISCRETE INPUT] is selected.
- You cannot open deck 1 while recording.
- You cannot fast-forward or rewind one deck while recording with the other.

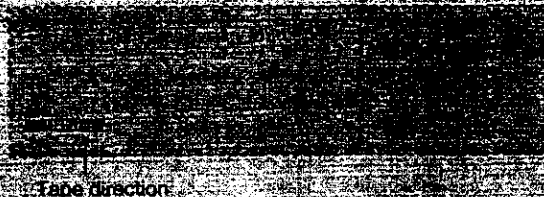
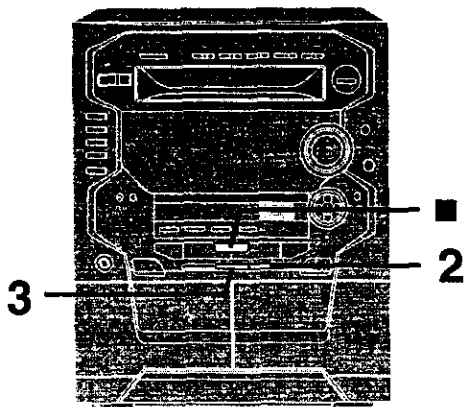

A

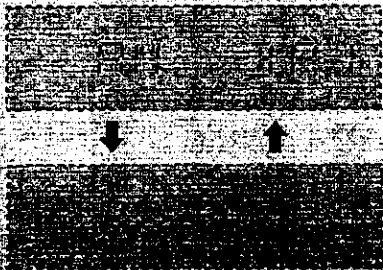
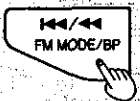
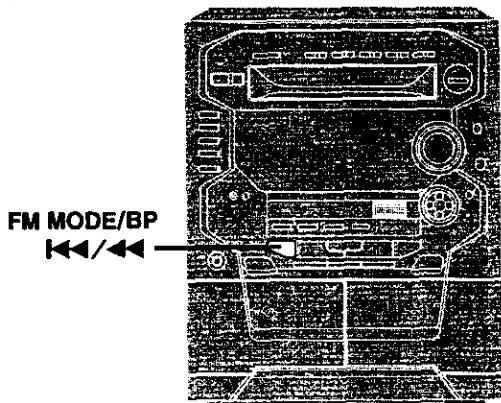

Preparation:

Insert the tape to be recorded on into deck 2.

Tape direction is automatically set to "▶".

Change the tape direction if you want to start recording from the reverse side. (⇒ page 22)

1. Select a radio station.

(⇒ page 15, steps 1 – 3)

2. Press [REV MODE] to select the reverse mode.

Every time you press the button;

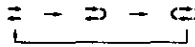

▶ : One side is recorded, then recording stops automatically.

◀, ▶ : Both sides (front side → reverse side) are recorded, then recording stops automatically.

3. Press [● REC/STOP] to start recording.

If you selected ◀ in step 2, the direction will automatically change to ▶ when recording starts.

To stop recording

Press [● REC/STOP] again.

Recording can also be stopped by pressing [■].

To cut an unnecessary part while recording

1. Press [● REC/STOP] during the unnecessary part. The cassette deck will stop.

2. Press [● REC/STOP] to resume recording again. Recording will continue in the same direction as before.

Note

When recording an AM broadcast, volume is momentarily interrupted when you start and stop the recording.

A

To reduce noise while AM recording (Beat proof function)

Press [◀/▶, FM MODE/BP] while recording.

Each time you press the button, BP 1 and BP 2 will be displayed alternately.

Select the position where there is less noise.

Sequential recording

Preparation:

1. Insert the tape to be recorded on into deck 2.
Tape direction is automatically set to "▶".
Change the tape direction if you want to start recording from the reverse side. (➡ page 22)
2. Insert the CD.

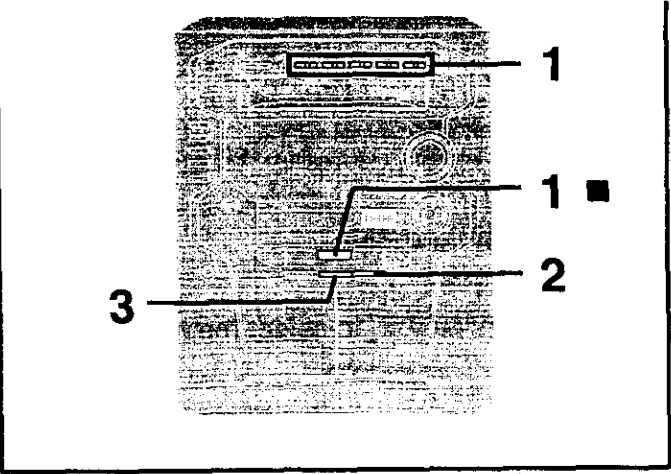

1. ① Press [CD 1] – [CD 5] to select the disc.
② Press [■] to stop the CD.
2. Press [REV MODE] to select the reverse mode.

Every time you press the button;

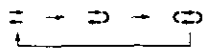

- ▶ : One side is recorded, then recording stops automatically.
- ↔ : Both sides (front side → reverse side) are recorded, then recording stops automatically.

3. Press [● REC/STOP] to start recording.
 - If you selected ↔ in step 2, the direction will automatically change to ▶ when recording starts.
 - The recording will proceed from the first track on the selected CD and will continue on through the last track of the final disc.
 - The tape deck stops automatically when the CD is finished.

To stop recording

- To add a 4 second silent interval before stopping Press [■]. The CD will stop automatically too.
- To stop recording without a silent interval Press [● REC/STOP]. The CD will stop automatically too.

To record programmed tracks

1. After step 2, program the track you want (performs steps 2 – 5 on page 19).
2. Press [● REC/STOP] to start recording.

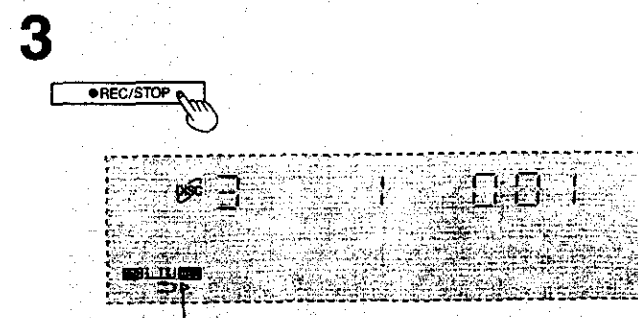
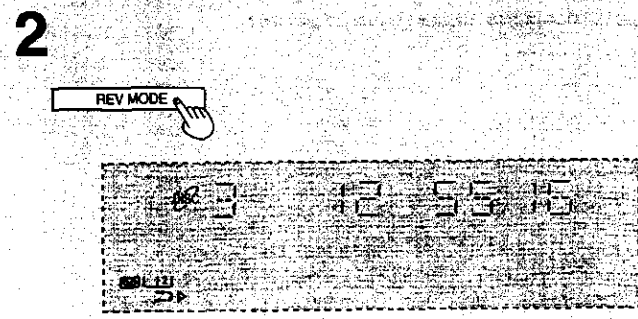
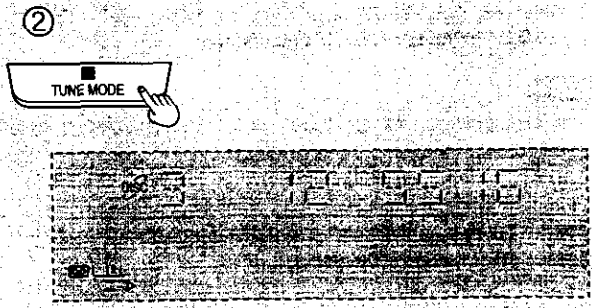
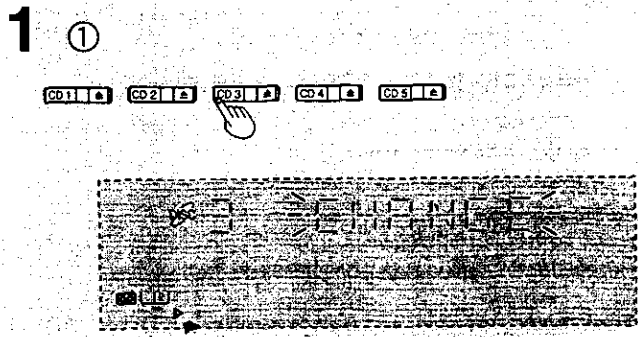

Tape direction

Recording operation

To record special CDs and tracks (CD Manager function)

This function makes it easier for you to select special CDs and tracks from amongst those loaded in the player.

- While recording, if a track is cut off in the middle at the end of the front side, it is re-recorded from the beginning on the reverse side.



The interrupted track is re-recorded in its entirety on the reverse side.

- At the end of the reverse side recording stops and the current track will be interrupted.

Preparation:

1. Insert the tape to be recorded on into deck 2.
Tape direction is automatically set to "▶".
Change the tape direction if you want to start recording from the reverse side. (⇒ page 22)
2. Insert the CD.

1. Press [CD].
2. Press [CD MANAGER] to select the desired mode.

Every time you press the button;

1-TRACK → 1-DISC → 1-ALL → NORMAL (OFF)

- 1-TRACK: Only one particular track is recorded.
 - 1-DISC: The tracks on only one particular disc are recorded.
 - 1-ALL: The same track numbers on each of the CDs are recorded in succession.
- (NORMAL: The original display is restored in about 3 seconds.)

3. Press [CD 1] – [CD 5] to select the disc.

Note

This step is not required if 1-ALL was selected in step 2.

4. Press [◀◀] or [▶▶] to select the desired track.

Note

This step is not required if 1-DISC was selected in step 2.

5. Press [● REC/STOP] to start recording.

To stop recording

- To add a 4 second silent interval before stopping
Press [■]. The CD will automatically stop too.
- To stop recording without a silent interval
Press [● REC/STOP]. The CD will stop automatically too.

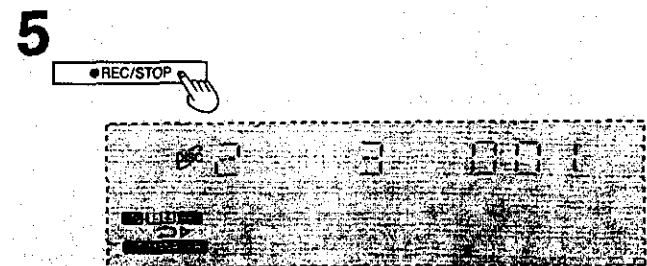
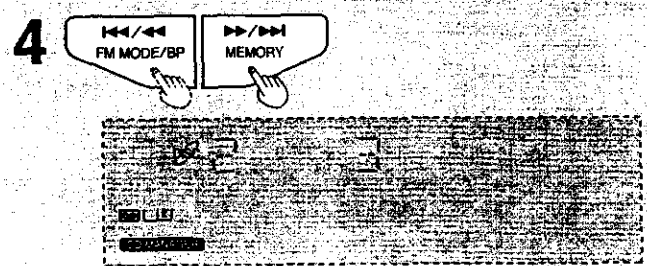
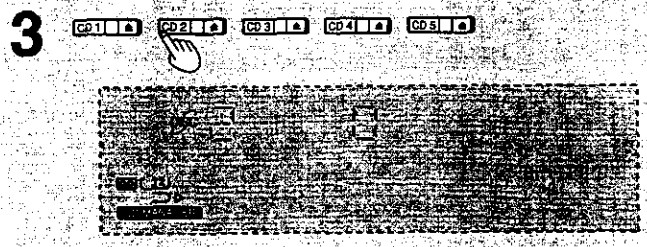
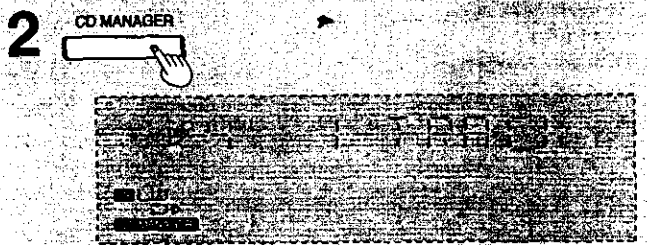
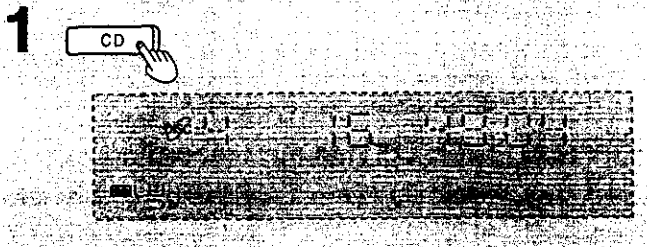
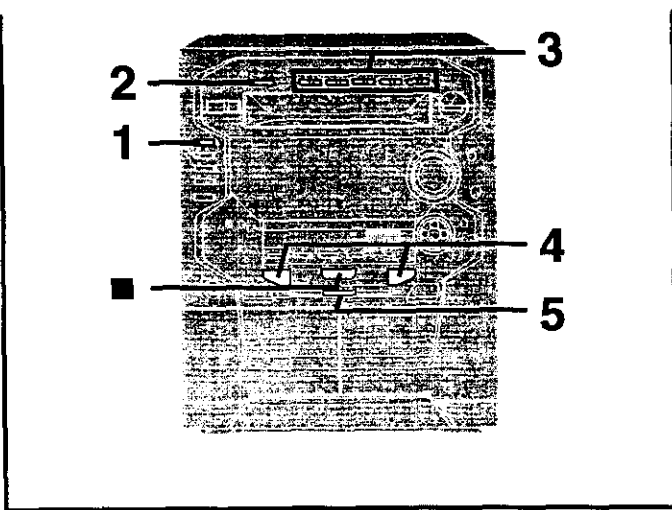

Tape-to-tape recording

The recording level will be recorded as they are on the tape being played back.

Preparation:

Insert the cassettes.

For playback: into deck 1

For recording: into deck 2

Tape direction is automatically set to "▶".

Change the tape direction if you want to start recording from the reverse side. (⇒ page 22)

1. Press [TAPE DECK 1/2].

2. Press [REV MODE] to select the reverse mode.

Every time you press the button;

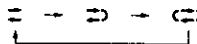

⇄ : One side is recorded, then recording stops automatically.

⇄, ⇄ : Both sides (front side → reverse side) are recorded, then recording stops automatically.

3. Press [TAPE EDIT] to start recording.

- If you selected ⇄ in step 2, the direction will automatically change to ⇄ when recording starts.

To stop recording:

Press [■].

Both decks will stop.

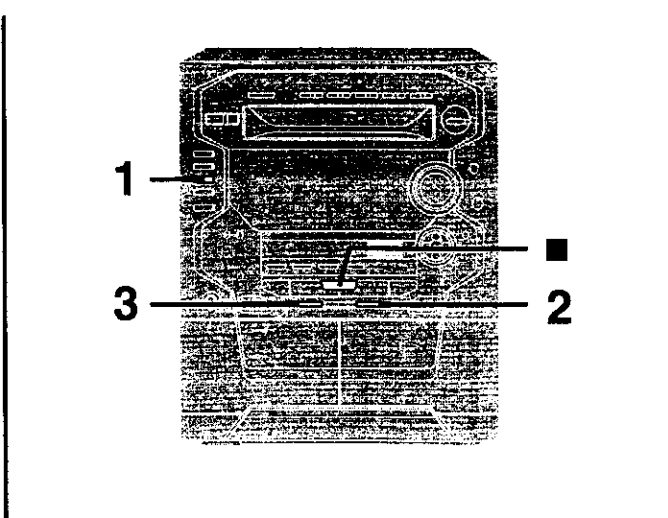

1

TAPE
DECK 1/2



2

REV MODE



3

TAPE EDIT

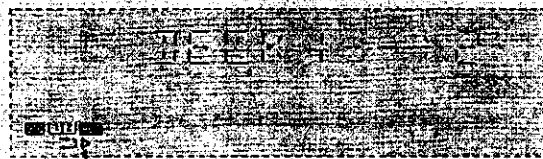

Tape direction of the tape you are recording onto

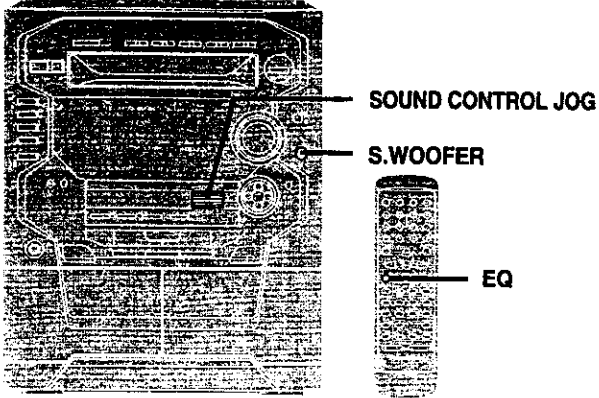

Press [S.WOOFER].

- When listening to the sound through the speakers
MID (medium) → MAX (high) → Light off (OFF)
- When listening to the sound through the headphones
Light on (ON) = Light off (OFF)

Note

All recordings are performed at the flat setting even if an alternative sound quality/sound field setting has been selected and the super woofer effect is set to ON.

B Using the built-in sound quality/sound field settings

Dial [SOUND CONTROL JOG] to select the sound quality or sound field.

When it is dialed down, the settings are selected in the following sequence.

- HEAVY (sound quality)**
Select this when playing rock or other kinds of music that sound better with an added punch.
- CLEAR (sound quality)**
Select this for jazz or other kinds of music for which clarity in the treble range is desired.
- SOFT (sound quality)**
Select this when listening to background music.
- DISCO (sound field)**
Select this to produce sound with the same kind of lengthy reverberations heard at a disco.
- LIVE (sound field)**
Select this to make vocals more alive.
- HALL (sound field)**
Select this to add an expansiveness to the sound to produce the atmosphere of a great concert hall.
- MANUAL (see page 28)**
- AI EQ (see page 29)**
- FLAT**
The original display is restored on the display panel in about 5 seconds.

To release the equalizer

Dial [SOUND CONTROL JOG] to select "FLAT".

When using the remote control to perform the operations described above

Press [EQ].

Each time this button is pressed, the setting is changed in the sequence described above.

A S.WOOFER

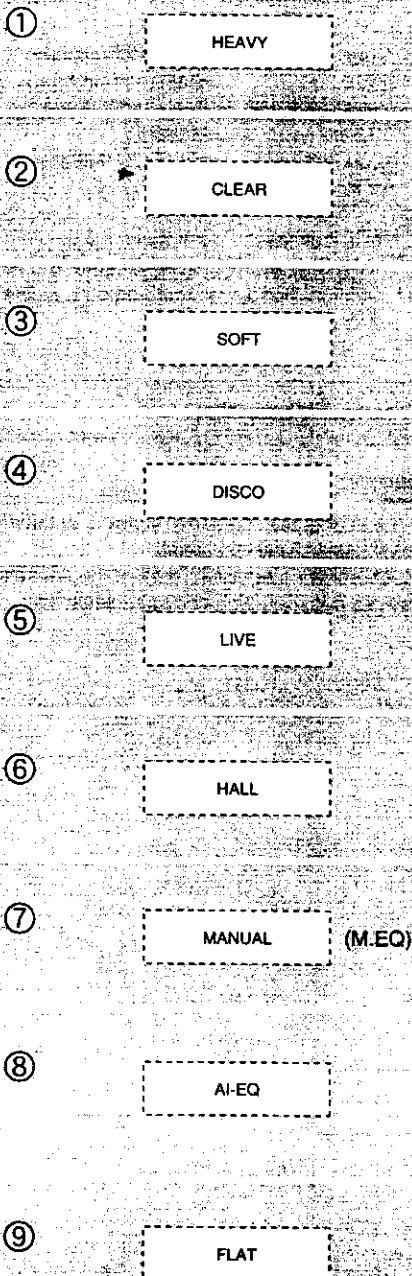
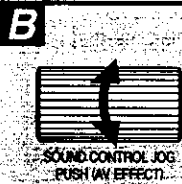

manual equalizer (Manual EQ)

1. Dial [SOUND CONTROL JOG] to select "MANUAL".

When it is dialed down, the settings are selected in the following sequence.

- HEAVY
- CLEAR
- SOFT
- DISCO
- LIVE
- HALL
- **MANUAL(M.EQ)**
- AI EQ
- FLAT

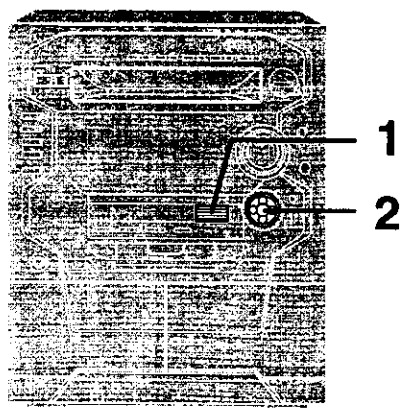

1

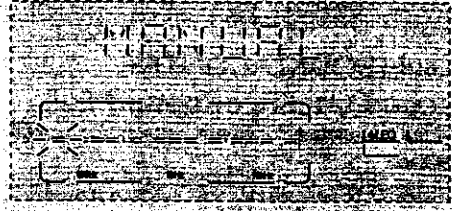

2. Adjust the sound quality.

① ← → direction: For selecting the range of the sound to be adjusted

Characteristics of each sound range

- 100 Hz: Super woofer range
- Around 330 Hz: Bass to midrange
- 1 kHz: Midrange
- Around 3.3 kHz: Midrange to treble
- 10 kHz: Treble

② ↓ ↑ direction: For adjusting the level
Repeat steps ① and ② to set the desired sound quality. The original display is restored on the display panel in about 5 seconds.

2

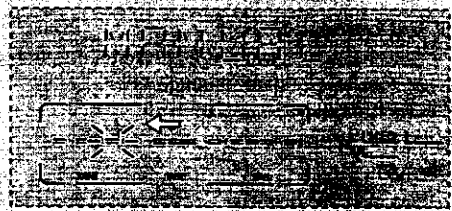
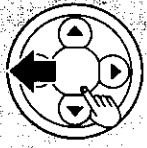
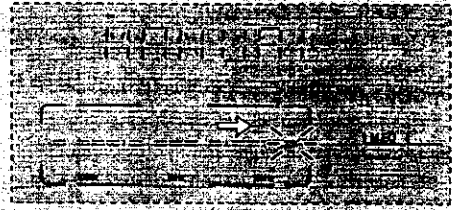
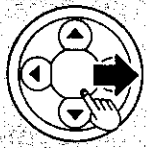

2

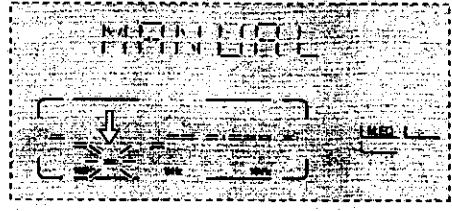
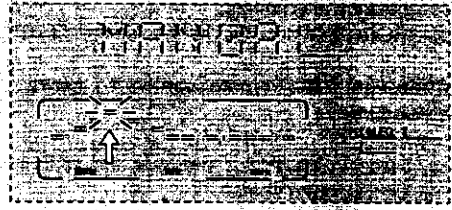

Sound quality / sound field operations

To release the equalizer

Dial [SOUND CONTROL JOG] to select "FLAT".

Note

- The sound quality setting is stored automatically. It is recalled when "MANUAL" is next selected.
- All recordings are performed at the flat setting even if an alternative sound quality setting has been selected.

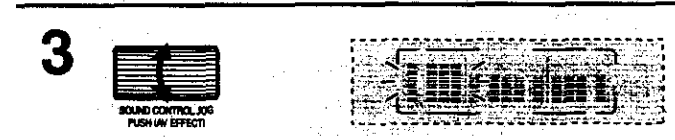
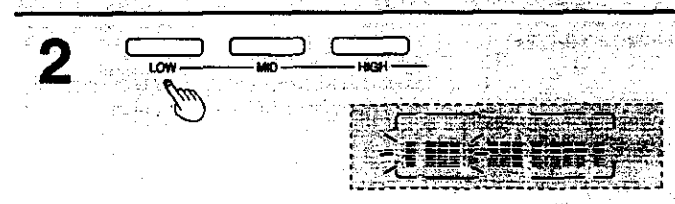
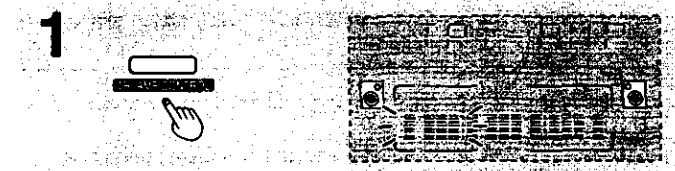
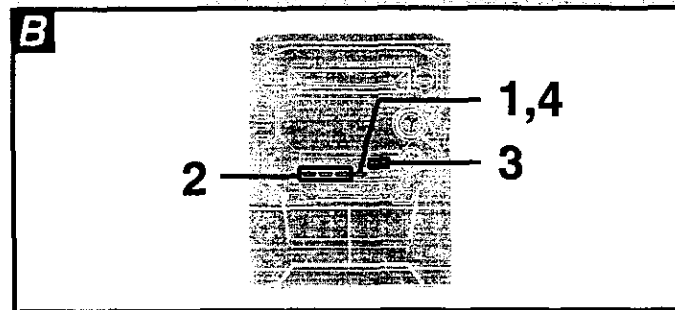
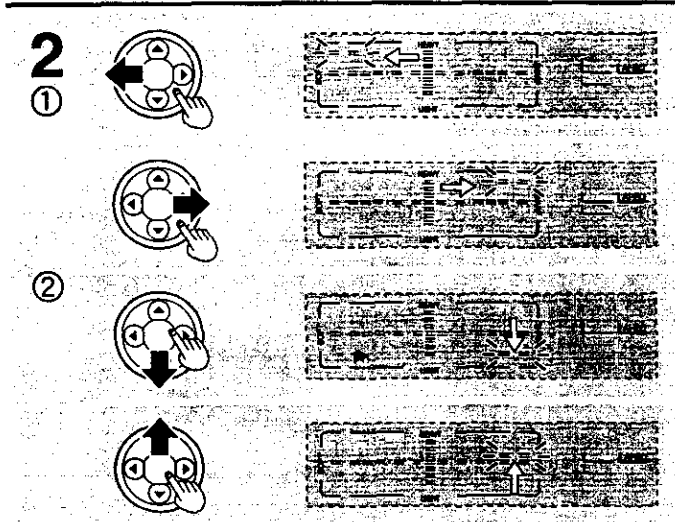
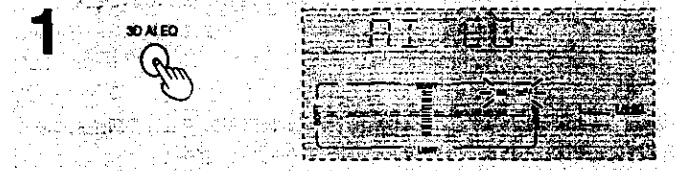
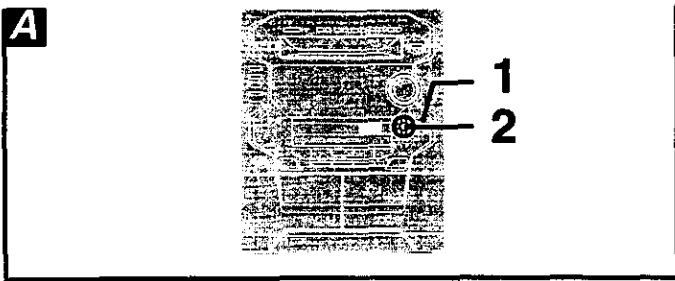

A acoustic image (AI) equalizer (3D AI EQ)

It is possible to use the acoustic image equalizer (AI EQ) together with the surround effect to create your own sound effect. The AI EQ equalizer uses the SOFT, SHARP, HEAVY and LIGHT sound quality coordinates to achieve subtle sound quality settings with ease.

1. Press [3D AI EQ] to adjust the surround level.

Every time you press the button;
AI EQ → 3D AI 1 → 3D AI 2

2. Adjust the sound quality.

- ① ← → direction: SOFT-SHARP setting
 - ② ↑ ↓ direction: LIGHT-HEAVY setting
- Repeat steps ① and ② to set the desired sound quality. The original display is restored on the display panel in about 5 seconds.

With the remote control

Press [◀], [▶], [▼], or [▲] to adjust the sound quality.

To release the equalizer

Dial [SOUND CONTROL JOG] to select "FLAT".

Note

- The sound quality setting is stored automatically. It is recalled when "AI EQ" is next selected.
- All recordings are performed at the flat setting even if an alternative sound quality setting has been selected.
- "3D AI 1" and "3D AI 2" cannot be selected while a surround system is on.

B Tri-amp control

The tri-amp control controls sound quality by allowing you to adjust the level of the amplifiers for the low, mid, and high regions. It is a type of manual equalizer and cannot be used with the other types of equalizers or when 6 CH DISCRETE INPUT is on.

1. Press [TRI-AMP CONTROL].

[LOW] button starts flashing.

2. (Within 5 seconds)

Press [LOW], [MID], or [HIGH] to select the setting.

The selected block starts flashing.



3. Dial [SOUND CONTROL JOG] to adjust the level.

- Select the surround mode appropriate to the source you are using. Read the following explanations to aid your selection.
- You may experience a reduction in sound quality when these surround systems and effects are used with some sources. If this occurs, either turn the surround system or effect off or reduce the level of the effect.

Note

- All the features are only effective if speakers are used. No discernible effect will be heard through headphones.

Sound quality / sound field operations

Surround system	Features	Recognizing the sound sources and software that can be used					
<p>6CH DISCRETE INPUT (Dolby Digital / DTS)</p>	<ul style="list-style-type: none"> • You will need a DVD player that has a built in decoder to enjoy DVDs with this unit. • Dolby Digital and DTS are discrete 6 (5.1) channel surround systems developed for cinema use. Not all Dolby Digital sources are recorded with 6 channels. Some sources marked Dolby Digital may be recorded in Dolby Surround, a 2 channel system. • Connect a subwoofer (not included) to the line out terminal on the rear panel of this system to increase the effect. 	<p>Software encoded with Dolby Digital can be identified with this mark.</p> <ul style="list-style-type: none"> • DVD  <p>Software encoded with DTS can be identified with this mark.</p> <ul style="list-style-type: none"> • DVD • Laser discs • CDs 					
<p>DOLBY PRO LOGIC</p>	<ul style="list-style-type: none"> • This system was developed to get a better sense of presence from sources encoded with Dolby Surround. • The feeling of position has been improved by the addition of a separate center speaker channel. • This unit has built-in Dolby Pro Logic circuit so you can enjoy Dolby Surround by connecting the speakers. 	<p>Software with the following mark is recorded in Dolby Pro Logic:</p> <ul style="list-style-type: none"> • Laser Disc • DVD • Video tape (VCR) • CD  <p>This mode cannot be used with the radio and 6CH DISCRETE INPUT mode.</p>					
<table border="1"> <tr> <td data-bbox="235 1430 428 1787" rowspan="2"> <p>SUPER SURROUND</p> </td> <td data-bbox="428 1430 613 1608"> <p>MOVIE mode</p> </td> </tr> <tr> <td data-bbox="428 1608 613 1787"> <p>MUSIC mode</p> </td> </tr> <tr> <td colspan="2" data-bbox="235 1787 613 2003"> <p>SIMULATED STEREO</p> </td> </tr> </table>	<p>SUPER SURROUND</p>	<p>MOVIE mode</p>	<p>MUSIC mode</p>	<p>SIMULATED STEREO</p>		<ul style="list-style-type: none"> • This mode adds surround effects to movie software that isn't recorded with the above systems. In MOVIE mode you can adjust the volume of the surround speaker to get the best surround effect. • This mode adds surround effects to normal music sources. • This mode adds stereo-like effects to monaural sound sources. 	<p>Any general sound source can be used.</p> <ul style="list-style-type: none"> • CD • TAPE • AUX <p>This mode cannot be used with the radio and 6CH DISCRETE INPUT mode.</p> <p>Any general sound source recorded in monaural can be used.</p> <ul style="list-style-type: none"> • CD • TAPE • AUX <p>This mode cannot be used with the radio and 6CH DISCRETE INPUT mode.</p>
<p>SUPER SURROUND</p>		<p>MOVIE mode</p>					
	<p>MUSIC mode</p>						
<p>SIMULATED STEREO</p>							

Add these audio effects to improve the experience

• Check the set-up of your speakers.

Set your speakers up to suit the surround mode you have selected to get the best surround effect. These modes cannot be used with the radio.

Virtual rear surround effect

- This mode is useful if you have to place your surround speakers on the front speakers because of the room's layout.
- This mode makes it seem like the sound from the surround speakers is coming from behind you.

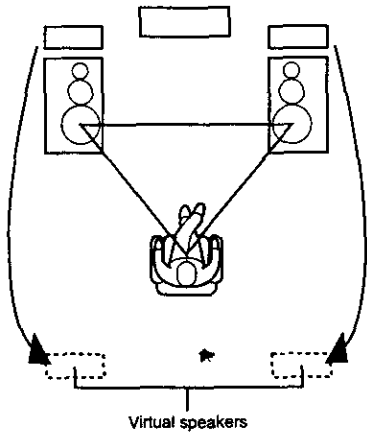

Center focus 1 effect

- This mode makes it seem like the sound from the center speaker channel (dialogue, etc.) is coming from within the television.
- The center speaker must be placed on top of the television.

Center focus 2 effect

- This is a more advanced version of Center focus 1. It makes dialogue clear even if the volume of the center channel is low.

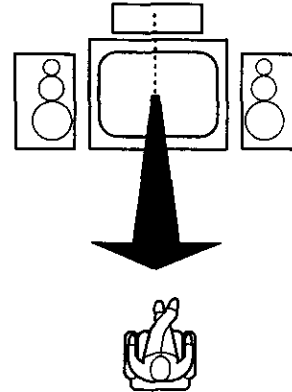

Multi rear surround effect

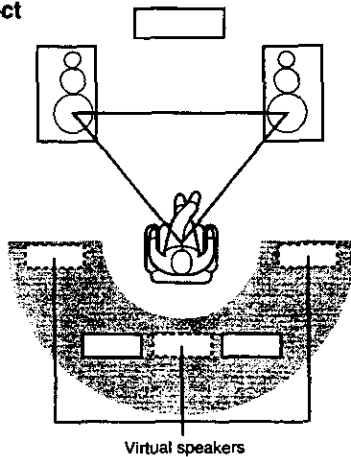

3D ENHANCED effect

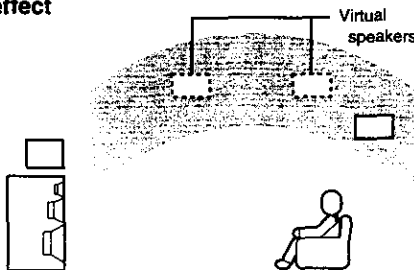

- Through processing of the surround sound signals, these modes make it seem like there are multiple surround speakers in your room.
- These modes increase the cinema-like sense of presence.

Seat position function

- This function helps maintain the sound signal position even if the listening position itself is changed.
- It is effective when using 6CH DISCRETE INPUT, DOLBY PRO LOGIC, or SUPER SURROUND.

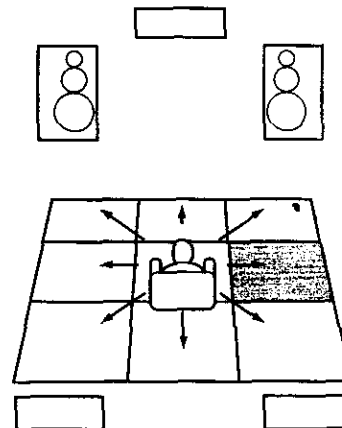

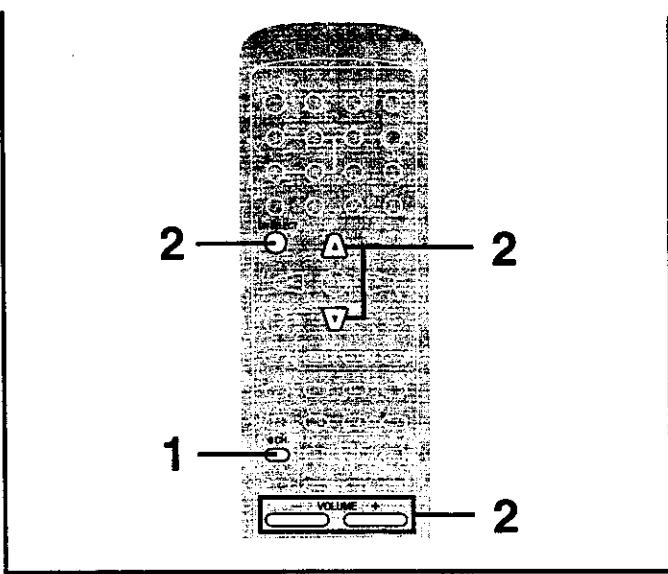

Preparation:

If you have connected a subwoofer (not included), press and hold [S.WOOFER] for about 2 seconds so "SUB W ON" is shown on the display.

1. Press [6CH].

The [6CH DISCRETE INPUT] indicator lights.

2. Adjust the volume of each speaker.

Sit in the normal listening position and make the adjustments with the remote control.

① **Output the test signal from the DVD player (not included).**
Set the channel level to 0 dB on the DVD player, and adjust the channel level on this system.

② **Press [VOLUME (- or +)].**
Set the volume to the normal listening level.

The following steps are for setting the output level of the front speakers and the other speakers to approximately the same level.

③ **Press [CH SELECT].**
Select the speaker channel to be adjusted.
L: Front speaker (Left)
C: Center speaker
R: Front speaker (Right)
RS: Surround speaker (Right)
LS: Surround speaker (Left)
SW: Subwoofer

④ **Press [▲] or [▼].**
Adjust the output level
▲ : Increases the output level
▼ : Decreases the output level
Repeat steps ③ and ④ to adjust the level accordingly.

Reference:

Add audio effects to improve the surround effect. (➡ pages 35, 36)

Note

You cannot record sound when [6CH DISCRETE INPUT] is selected. To record from DVDs, reconnect the DVD player (MIXED OUT) to AUX1 or 2 terminal on this unit.

Sound quality / sound field operations

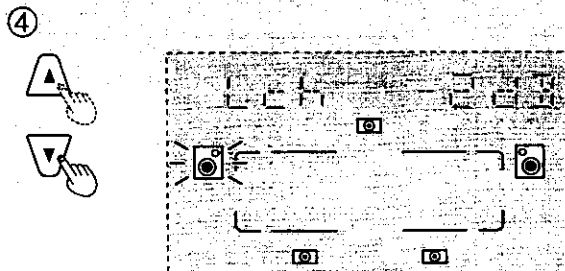
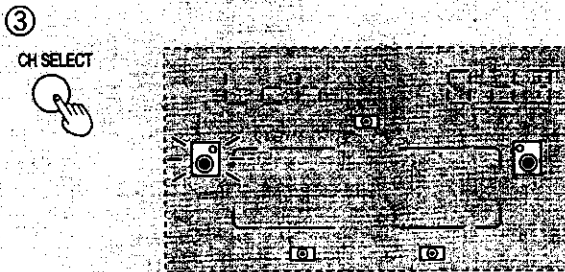
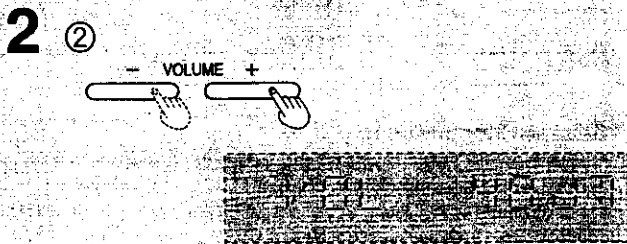
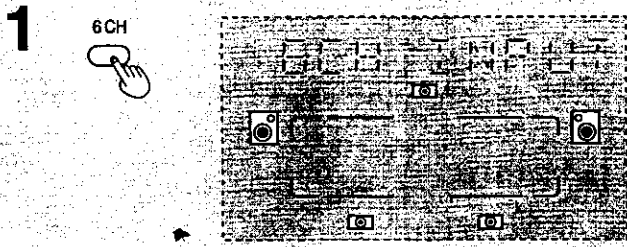

Enjoying Sound with DOLBY PRO LOGIC (DOLBY PRO LOGIC)

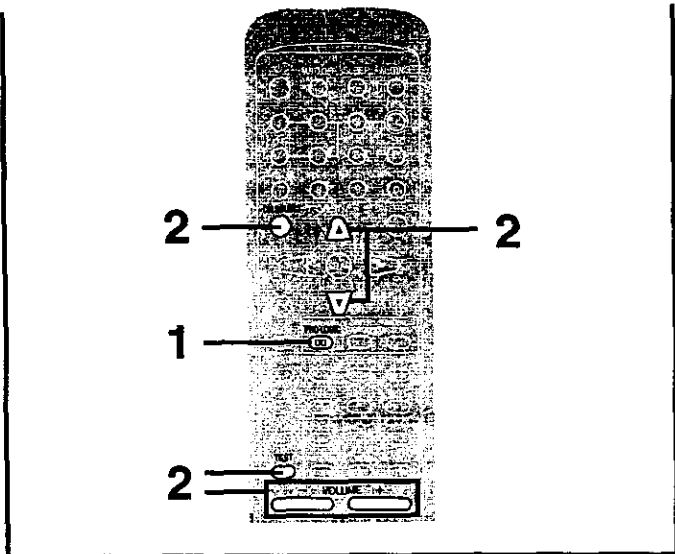

1. Press [PRO LOGIC].

The [PRO LOGIC] indicator lights.

2. Adjust the volume of each speaker.

Sit in the normal listening position and make the adjustments with the remote control.

① Press [TEST].

A test signal is output.
The speaker outputting the test signal is displayed while the test is running.

- L: Front speaker (Left)
- C: Center speaker
- R: Front speaker (Right)
- S: Surround speakers

② Press [VOLUME (- or +)].

Set the volume to the normal listening level.

The following steps are for setting the output level of the front speakers and the other speakers to the same listening level.

③ Press [CH SELECT].

Select the speaker channel to be adjusted.

④ Press [▲] or [▼].

Adjust the output level.

- ▲ : Increases the output level
- ▼ : Decreases the output level

Repeat steps ③ and ④ to adjust the level accordingly.

To stop the test signal
Press [TEST] again.

To playback a Dolby Surround source with Dolby Pro Logic

1. Press [PRO LOGIC].

The [PRO LOGIC] indicator lights.

2. Playback a Dolby Surround source.

To turn off DOLBY PRO LOGIC

Press [PRO LOGIC].
The [PRO LOGIC] indicator goes out.

Reference:

Add audio effects to improve the surround effect. (→ pages 35, 36)

Manufactured under license from Dolby Laboratories.
"Dolby", the double-D symbol and "Pro Logic" are trademarks of Dolby Laboratories.

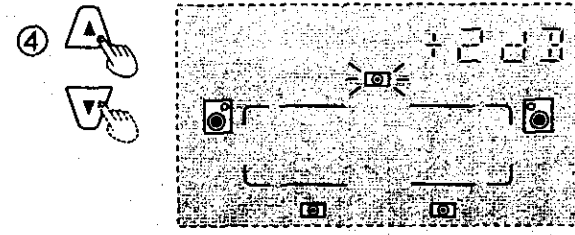
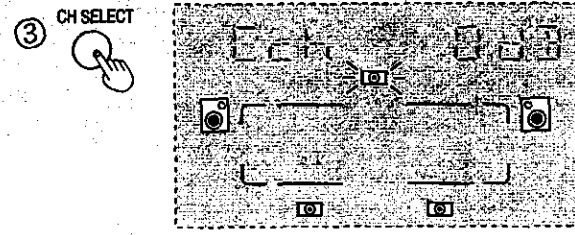
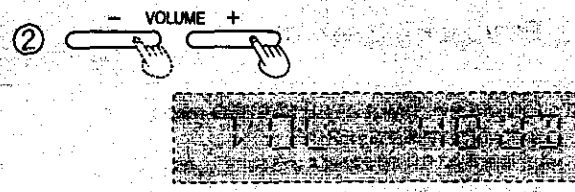
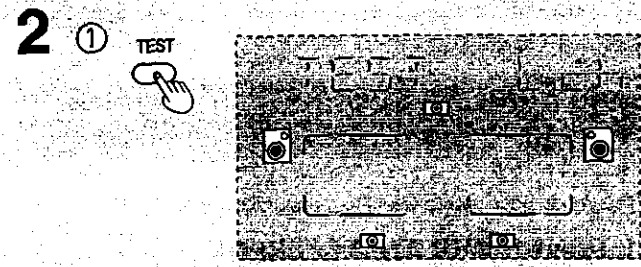
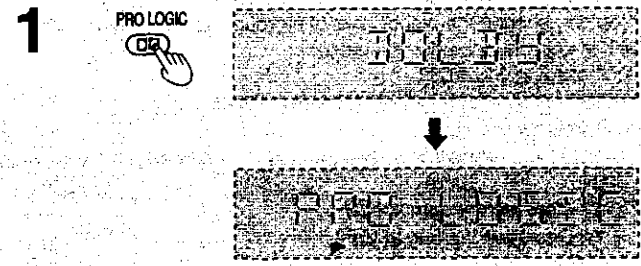

Sound quality / sound field operations

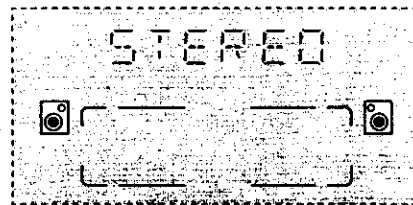
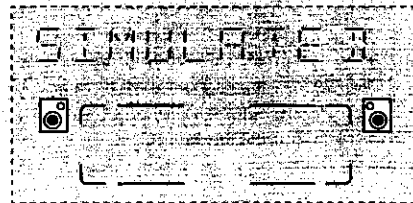
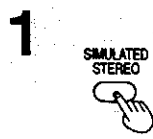
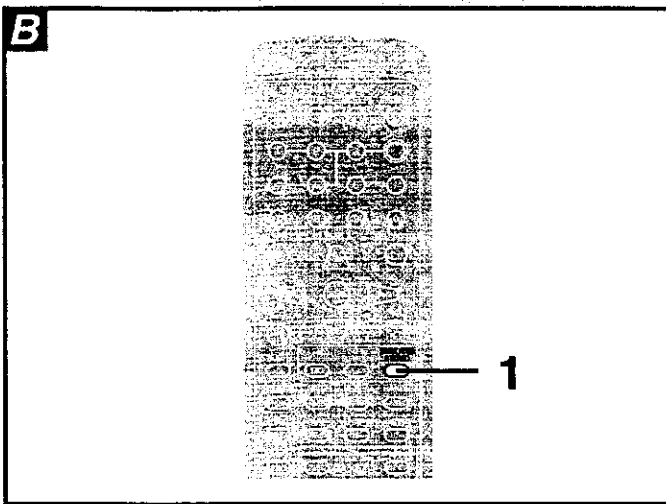
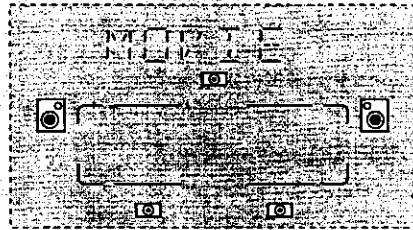
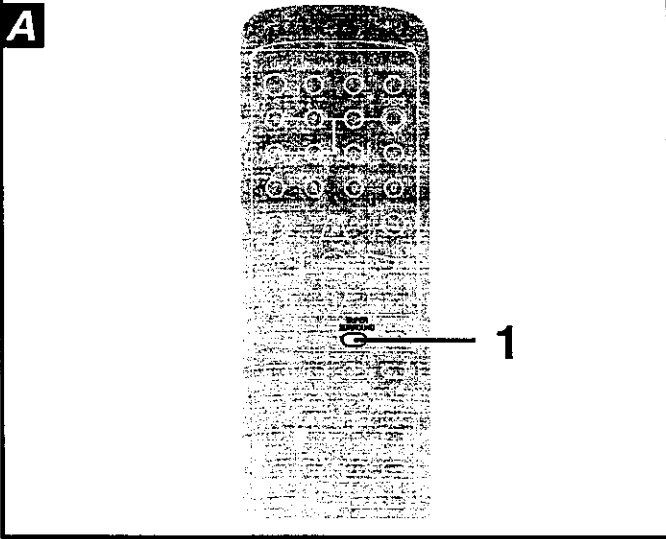

A Enjoying sound with superaural effects (SUPER SURROUND)

- This mode adds the 5ch surround effect to the normal stereo sources.
- SUPER SURROUND is only effective if speakers are used. No discernable effect will be heard through headphones.

1. Press [SUPER SURROUND] and select MOVIE mode or MUSIC mode.

Each time the button is pressed;
 MUSIC → MOVIE → STEREO SOUND (off)

2. Playback the source.

To turn off the SUPER SURROUND mode

Press [SUPER SURROUND] to select "STEREO SOUND".

To adjust the volume of surround speakers

You can change the output level of surround speakers manually. While enjoying the desired source:

1. Press [CH SELECT].

The output level of surround speakers is displayed.

2. Press[▲] or [▼].

Adjust the output level. The level can be adjusted between +6 and -10.

▲ : Increase the output level

▼ : Decrease the output level

Reference:

Add audio effects to improve the surround effect. (→ pages 35, 36)

B Enjoying sound with simulated stereo (SIMULATED STEREO)

This mode adds stereo effect to monaural sources.

1. Press [SIMULATED STEREO].

The [SIMULATED STEREO] indicator lights.

2. Playback the source.

To turn off the SIMULATED STEREO mode

Press [SIMULATED STEREO].

The [SIMULATED STEREO] indicator goes out.

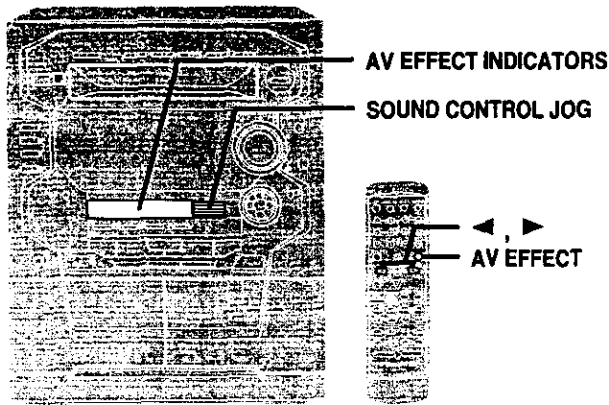

A Using the virtual rear surround effect (VIRTUAL REAR SRND)

- When the surround speakers are put on the front speakers, this mode makes it seem like the sound from the surround speakers is coming from behind you.
- This mode can be used with DOLBY PRO LOGIC, MOVIE (SUPER SURROUND), and 6CH DISCRETE INPUT.

Push [SOUND CONTROL JOG] to turn on the AV EFFECT.
Dial [SOUND CONTROL JOG] to select "VIRTUAL REAR SRND".

So the [VIRTUAL REAR SRND] indicator flashes.

Push [SOUND CONTROL JOG] (ON).

To turn off the VIRTUAL REAR SRND mode

Push [SOUND CONTROL JOG] and dial [SOUND CONTROL JOG] to select "VIRTUAL REAR SRND".

Push [SOUND CONTROL JOG] (OFF).

With the remote control

1. Press [AV EFFECT].
2. Press [◀] or [▶] so the [VIRTUAL REAR SRND] indicator flashes.
3. Press [AV EFFECT] (ON/OFF).

B Using the multi rear surround effect (MULTI REAR SRND)

- This mode makes it seem like there are multiple surround speakers in your room.
- This mode can be used with DOLBY PRO LOGIC, MOVIE (SUPER SURROUND), and 6CH DISCRETE INPUT.

Push [SOUND CONTROL JOG].
Dial [SOUND CONTROL JOG] to select "MULTI REAR SRND".

So the [MULTI REAR SRND] indicator flashes.

Push [SOUND CONTROL JOG] (ON).

To turn off the MULTI REAR SRND mode

Push [SOUND CONTROL JOG] and dial [SOUND CONTROL JOG] to select "MULTI REAR SRND".

Push [SOUND CONTROL JOG] (OFF).

With the remote control

1. Press [AV EFFECT].
2. Press [◀] or [▶] so the [MULTI REAR SRND] indicator flashes.
3. Press [AV EFFECT] (ON/OFF).

C Using the center focus effect (CENTER FOCUS 1, 2)

- When the center speaker is put on the TV set, this mode makes it seem like the sound from the center speaker is coming from within the television.
- This mode can be used with DOLBY PRO LOGIC, 6CH DISCRETE INPUT.

Push [SOUND CONTROL JOG].
Dial [SOUND CONTROL JOG] to select "CENTER FOCUS 1" or "CENTER FOCUS 2".

So the [CENTER FOCUS 1] or [CENTER FOCUS 2] indicator starts flashing.

Push [SOUND CONTROL JOG] (ON).

To turn off the CENTER FOCUS mode

Push [SOUND CONTROL JOG] and dial [SOUND CONTROL JOG] to select "CENTER FOCUS 1" or "CENTER FOCUS 2".

Push [SOUND CONTROL JOG] (OFF).

With the remote control

1. Press [AV EFFECT].
2. Press [◀] or [▶] so the [CENTER FOCUS 1] or [CENTER FOCUS 2] indicator starts flashing.
3. Press [AV EFFECT] (ON/OFF).

A

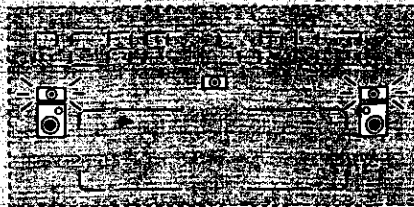
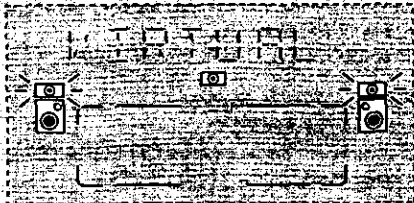

B

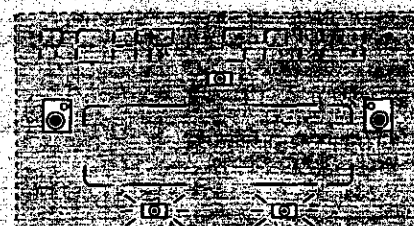
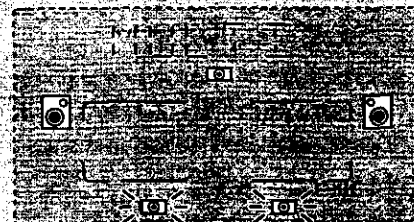

C

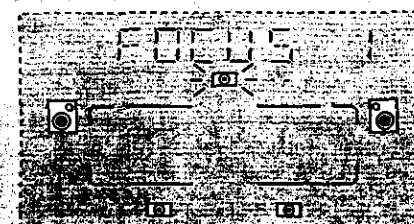
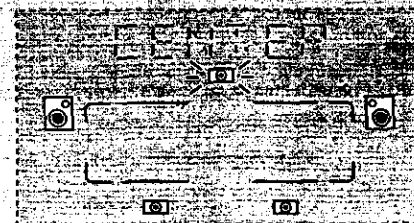

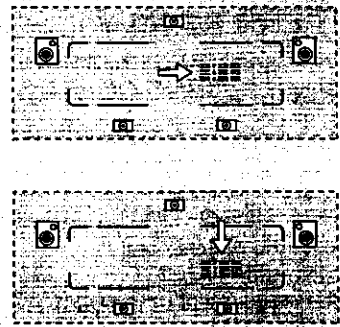
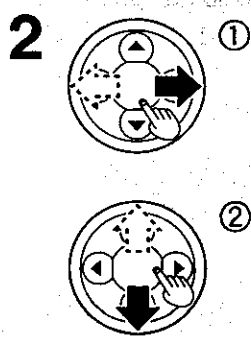
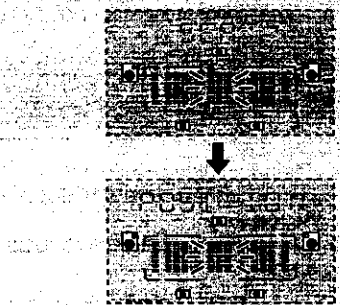
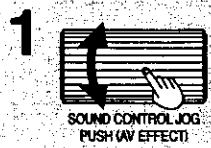
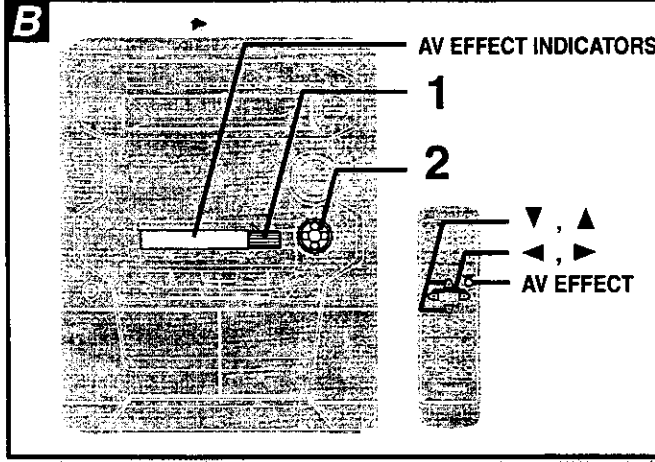
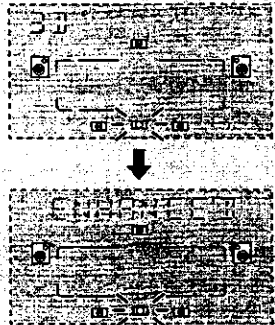
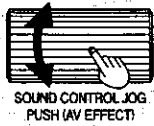
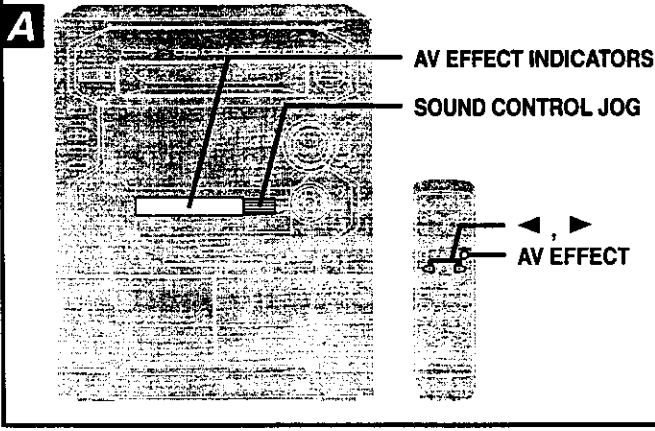

A Using the 3D ENHANCED mode (3D ENHANCED)

- This mode makes it seem like there are multiple surround speakers in your room.
- This mode can be used with DOLBY PRO LOGIC, MOVIE (SUPER SURROUND), and 6CH DISCRETE INPUT.

Push [SOUND CONTROL JOG].
Dial [SOUND CONTROL JOG] to select "3D ENHANCED".

So the [3D ENHANCED] indicator start flashing.

Push [SOUND CONTROL JOG] (ON).

To turn off the 3D ENHANCED mode

Push [SOUND CONTROL JOG] and dial [SOUND CONTROL JOG] to select "3D ENHANCED".

Push [SOUND CONTROL JOG] (OFF).

With the remote control

1. Press [AV EFFECT].
2. Press [◀] or [▶] so the [3D ENHANCED] indicator starts flashing.
3. Press [AV EFFECT] (ON/OFF).

B Using the seat position function (SEAT POSITION)

- This function lets you adjust the listening position for better effect.
- This mode can be used with DOLBY PRO LOGIC, MOVIE (SUPER SURROUND), and 6CH DISCRETE INPUT.

1. Push [SOUND CONTROL JOG].
Dial [SOUND CONTROL JOG] to select "SEAT POSITION".

So the [SEAT POSITION] indicator flashes.

Push [SOUND CONTROL JOG](ON).

While the indicator is flashing change the seat position.

2. (Within 10 seconds)

Adjust the seat position.

To turn off the SEAT POSITION mode

Push [SOUND CONTROL JOG] and dial [SOUND CONTROL JOG] to select "SEAT POSITION".

Push [SOUND CONTROL JOG](OFF).

With the remote control

1. Press [AV EFFECT].
 2. Press [◀] or [▶] so the [SEAT POSITION] indicator flashes.
 3. Press [AV EFFECT] (ON).
 4. Press [◀], [▶], [▼], or [▲] to adjust the seat position.
- To turn it off; after steps 1 and 2, press [AV EFFECT] (OFF).

Note

When used with virtual rear surround, seat position is changed in 3 horizontal steps.

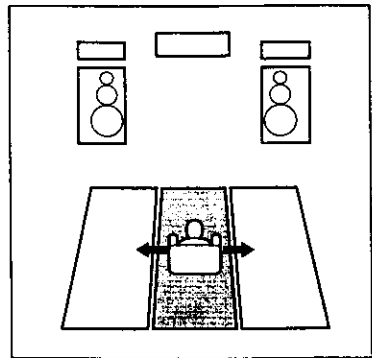

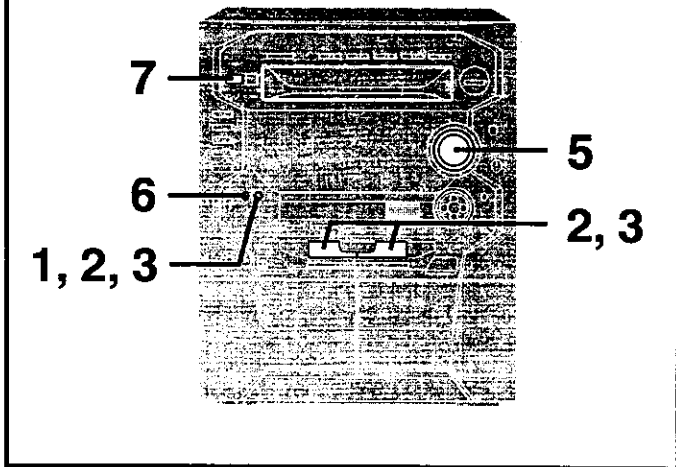

Using the play timer

Preparations

- Switch on the power.
- Make sure that you have completed "Setting the time" on page 13. The figure shows how to set the play timer to play from 6:30 a.m. to 7:40 a.m.

1. Press [CLOCK/TIMER] to select "⌚ PLAY".

Every time you press the button;

CLOCK → ⌚PLAY → ⌚REC → Previous display

2. "ON" time setting

(Within 8 seconds or so)

- ① Press [TUNE/TIME ADJ (∨ or ∧)] to select the starting time.
- ② Press [CLOCK/TIMER].

3. "OFF" time setting

- ① Press [TUNE/TIME ADJ (∨ or ∧)] to select the ending time.
- ② Press [CLOCK/TIMER].

4. Source selection

Select the desired source and then prepare for playing.

To play CD(s)

Press [CD] and insert CD(s).

If more than 1 CD is loaded

Press [CD 1] - [CD 5] to select the CD you want to hear first, and press [■].

Note

Disc selection does not become part of the timer memory.

To play tape(s)

Press [TAPE] and insert tape(s).

If tapes are loaded in both decks, playback will start from deck 2.

To play the radio

Press [TUNER] and tune in the desired station.

To play the external unit

Press [AUX1/2] or [6CH DISCRETE INPUT].

5. Play volume setting

Turn [VOLUME] to adjust the playback volume.

6. Press [⌚ PLAY/⌚ REC] to select "⌚ PLAY".

Every time you press the button;

⌚PLAY → ⌚REC → (off)

7. Press [POWER] to switch off the power.

The timer play will start at the preset time with volume increasing gradually up to the volume level you preset.

To switch the timer OFF

Press [⌚ PLAY/⌚ REC] and check "⌚ PLAY" goes out.

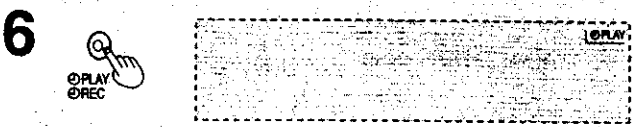
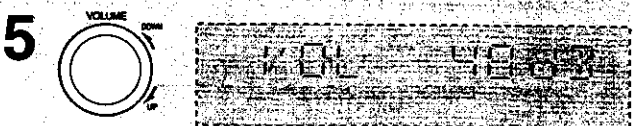
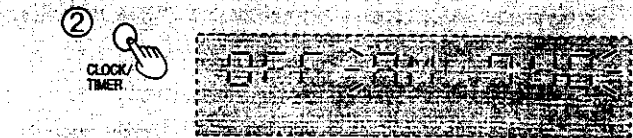
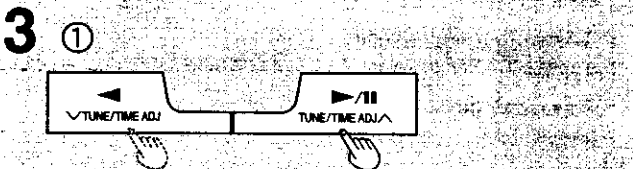
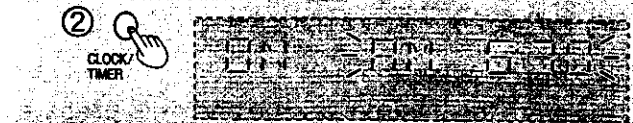
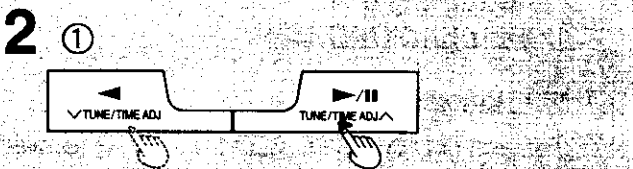
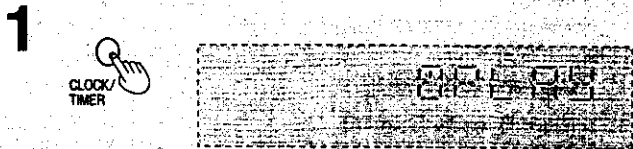

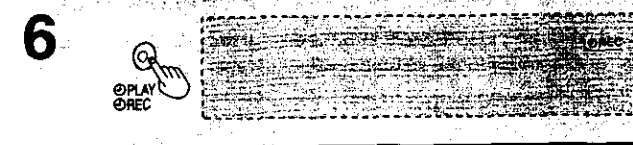
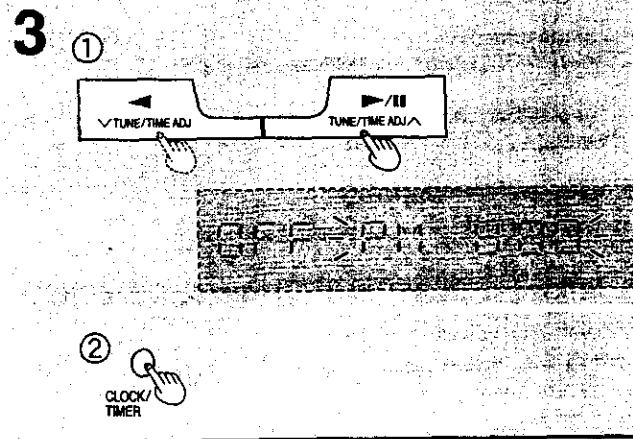
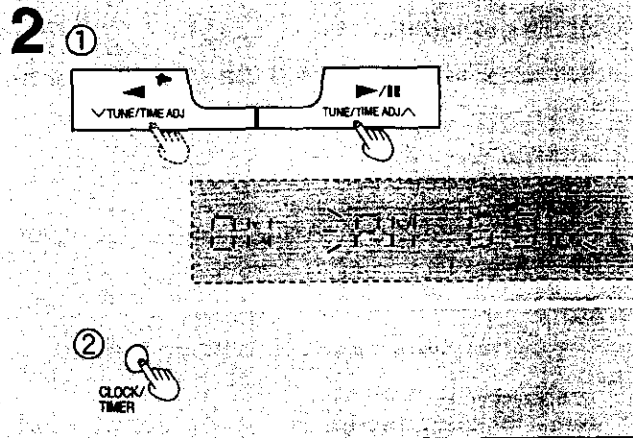
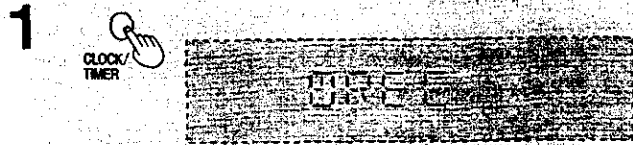
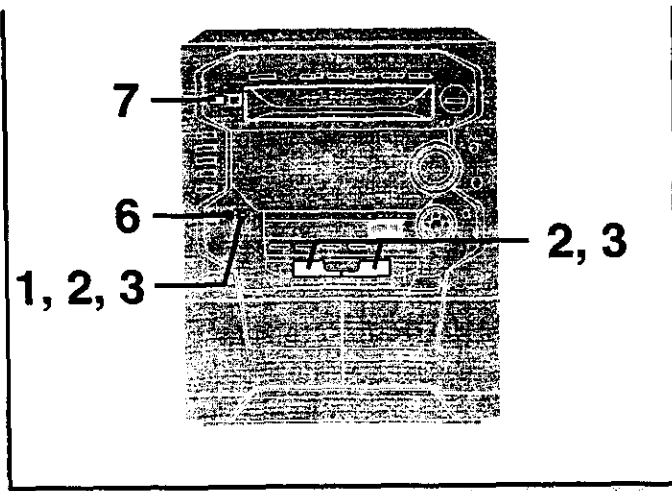

Timer and others

Using the timer

Using the record timer

Preparations

- Switch on the power.
- Make sure that you have completed "Setting the time" on page 13.

Set the timer at least 2 minutes before you want to start recording.

The figure shows how to set the record timer for recording from 6:30 p.m. to 8:00 p.m.

1. Press [CLOCK/TIMER] to select "⌚ REC".

Every time you press the button;

CLOCK → ⌚PLAY → ⌚REC → Previous display

2. "ON" time setting

(Within 8 seconds or so)

- 1 Press [TUNE/TIME ADJ (∨ or ∧)] to select the starting time.
- 2 Press [CLOCK/TIMER].

3. "OFF" time setting

- 1 Press [TUNE/TIME ADJ (∨ or ∧)] to select the ending time.
- 2 Press [CLOCK/TIMER].

4. Source selection

Select the desired source and then prepare for recording.

To record from the radio

Press [TUNER] to select the band and tune in the desired station.

To record the external unit

Press [AUX1/2].

Note

You cannot record sound when [6CH DISCRETE INPUT] is selected.

5. Prepare for recording.

1. Insert a tape into deck 2 with the side on which the recording will start facing you.
2. Select the reverse mode.

Note

Reverse mode does not become part of the timer memory.

6. Press [⌚ PLAY/⌚ REC] to select "⌚ REC".

Every time you press the button;

⌚PLAY → ⌚REC → (off)

7. Press [POWER] to switch off the power.

About 30 seconds before the set time, the system mutes all sound automatically.

To switch the timer OFF

Press [⌚ PLAY/⌚ REC] and check "⌚ REC" goes out.

Using the play/record timer

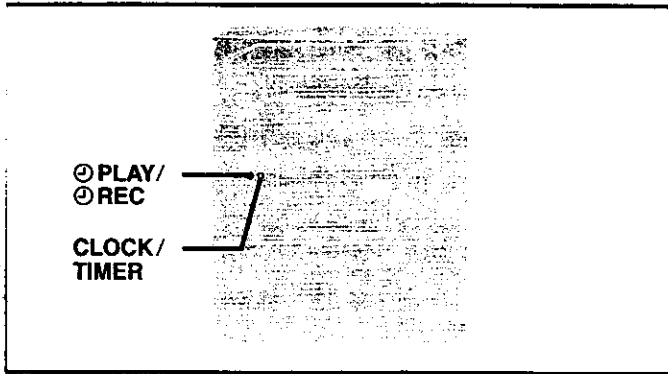

If you set the timer incorrectly
Repeat the procedure from step 1.

To check settings

While the unit is on and the "⊕ PLAY" (or ⊕ REC) indicator is on, press [CLOCK/TIMER] so "⊕ PLAY" (or ⊕ REC) appears on the display.

Two seconds after "⊕ PLAY" (or ⊕ REC) appears, the settings are displayed in the following order.

- For play timer
 - ① Play start time
 - ② Play end time
 - ③ Play source
 - ④ Playback volume
- For record timer
 - ① Recording start time
 - ② Recording end time
 - ③ Recording source

To enjoy the desired source after the timer setting is completed

The volume level and music source are stored in the timer memory and the timer will start in these preset conditions. However the Disc number and reverse mode do not get stored in the timer memory.

1. After step 7, turn on the unit and start playing the desired source.
2. Reset the Disc number and reverse mode if you have changed any of them, confirm that a Disc or cassette is inserted, then press [POWER] to put the unit on standby.

Turning the timer ON/OFF

One of the timers is on when the [⊕ PLAY/ ⊕ REC] button is alight. When the unit is on (or off and NORMAL mode) you can confirm which is on by checking the indicators on the display.

When the unit is off and in ECO mode, press [CLOCK/TIMER].

The display will then show which timer is on and the settings that have been made (see above).

To change the timer, press [⊕ PLAY/ ⊕ REC].

Each time the button is pressed the setting changes as follows.

⊕PLAY → ⊕REC → (off)

Note

- If the power is on, the timer will not function. The system must be in the standby mode.
- If you switch the power to the standby mode while the play/record timer is functioning, the OFF time setting will not be activated.
- If "AUX1/2" or "6CH DISCRETE INPUT" is selected as the source, when the timer comes ON, the system will turn ON and will engage "AUX1/2" or "6CH DISCRETE INPUT" as the source. If you want to playback or record from a connected component, set the component's timer to the same time. (See the instruction manual that came with the component.)
- The play timer cannot be used in combination with the record timer.

Using the sleep timer

This timer turns power to your system OFF at the set time (Max. 2 hours, settable at 30 minute intervals). It lets you fall asleep listening to music.

by remote control only

The figure shows how to set the system to standby mode after 30 minutes.

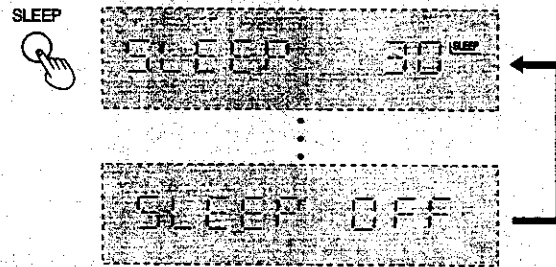
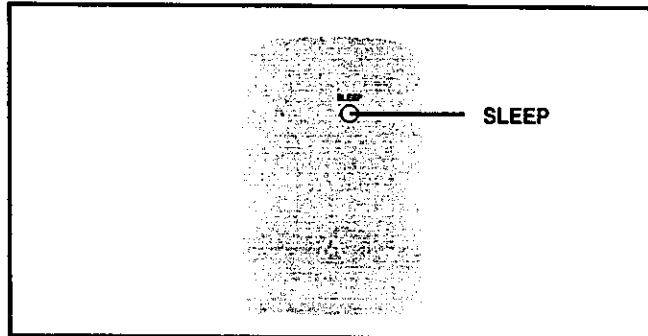

While enjoying the desired source:

Press [SLEEP] to select the desired time.

Every time you press the button;

30 → 60 → 90 → 120 → OFF

The system is turned off after the set time has elapsed.

To cancel the sleep timer:

Press [SLEEP] to select "OFF".

To confirm the remaining time:

(only while power is ON)

Press [SLEEP].

To change the time remaining during operation:

Press [SLEEP] to show the remaining time then press [SLEEP] to select the desired time.

Note

- The sleep timer turns OFF automatically the moment you attempt to edit-record a CD using CD Manager function.
- The sleep timer can be used in combination with the play/record timer.
The sleep timer always has priority.
Be sure not to overlap timer settings.

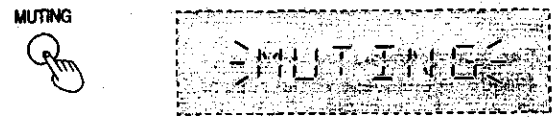
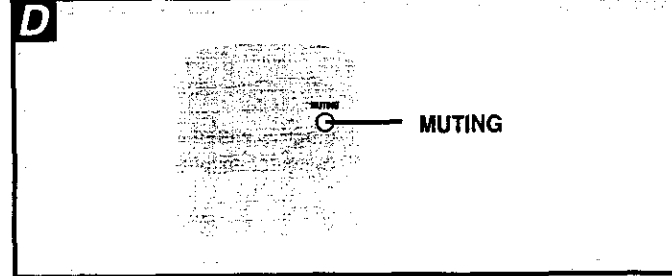
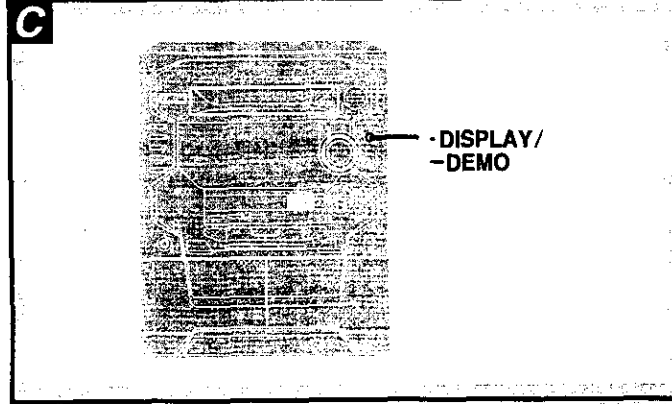
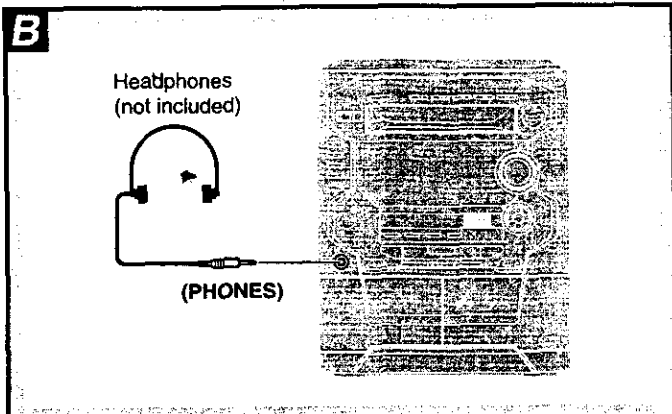
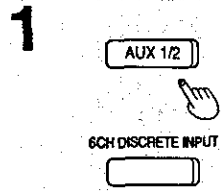
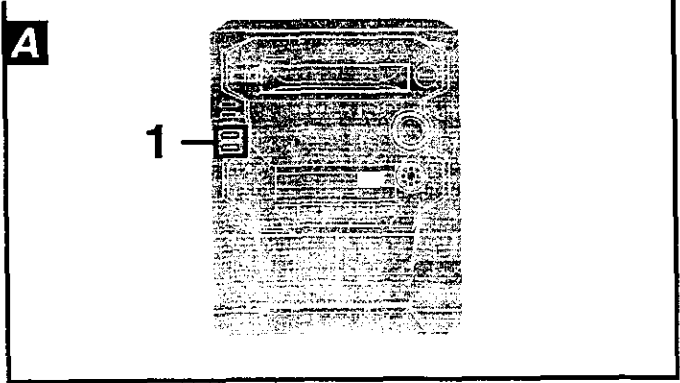

Timer and others

Using an external unit

A Listening to an external source

(See page 9 for external unit connection.)

1. Press [AUX1/2] or [6CH DISCRETE INPUT].
The power will come on automatically.
2. Start playback from the external source.
(For details, refer to the owner's manual of the equipment.)

Recording from an external source

1. Press [▲ DECK 2 OPEN] and insert the tape.
Close the holder by hand.
2. Press [REV MODE] to select the reverse mode.
3. Press [AUX1/2] to select the external source.
4. Press [● REC/STOP].
Recording starts.
5. Start playback from the external source.
(For details, refer to the owner's manual of the equipment.)

You cannot record sound when [6CH DISCRETE INPUT] is selected.

B Listening with headphones

Reduce the volume level, and connect the headphones.
Plug type: 3.5 mm stereo

Note

Avoid listening for prolonged periods of time to prevent hearing damage.

Convenient functions

C Switching displays

Press [-DISPLAY/-DEMO] to select the desired spectrum analyzer.

Every time you press the button;

NORMAL → Peak hold → Aurora → off (Dimmer)

When the spectrum analyzer² is off, the display is dimmed and indicators, except for the AC supply indicator, are turned off for better television viewing.

D To mute the volume

by remote control only

This feature is convenient when you have a telephone call, etc.

Press [MUTING].

Press the button again to cancel.

"MUTING" goes out.

Muting can also be cancelled by lowering the volume all the way (---dB).

When the system is turned off, the muting operation will be automatically cancelled.

Concerning compact discs

With this system, you can only play CDs having this mark.



A However, do not use irregular shape CDs. CDs of the sort can damage the unit.

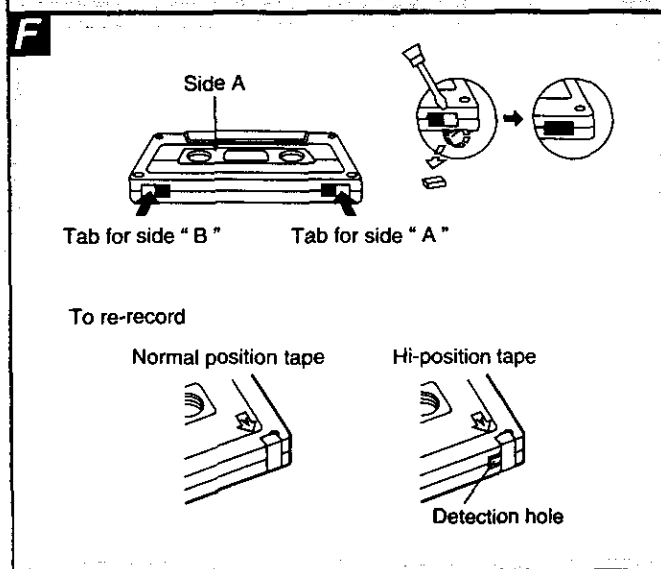
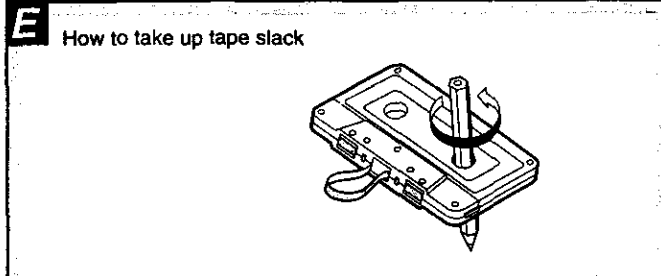
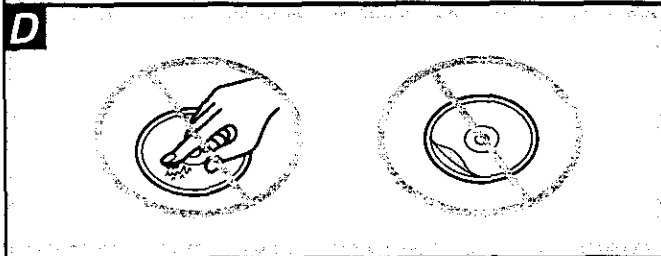
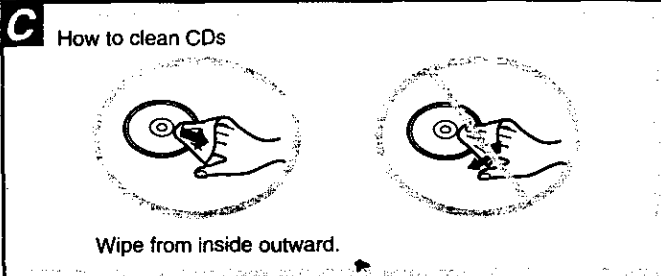
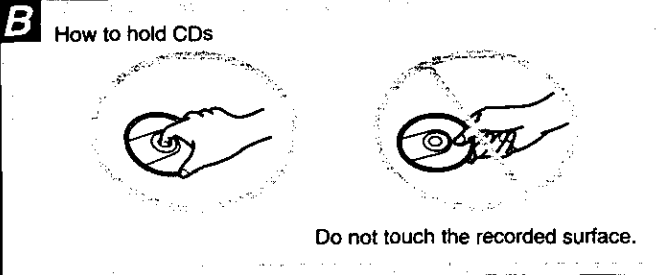
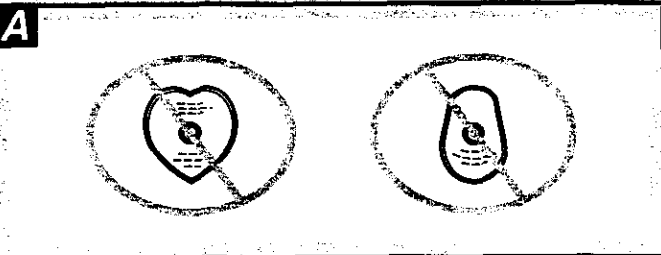

B - D Handling precautions

- If you are taking the CD from a cold to a warm environment, moisture may form on the CD. Wipe this off with a soft, dry, lint-free cloth before using the CD.
- Do not write on the label side with a ball-point pen or other writing instrument.
- Do not use record cleaning sprays, benzene, thinner, static electricity prevention liquids or any other solvent.
- Do not attach labels or stickers to CDs. (Do not use CDs with exposed adhesive from tape or left over peeled off stickers.)
- Do not use scratch-proof protectors or covers other than those specified for use with this system.
- Do not use CDs printed with non-commercial label printers.

Storage precautions

Be sure to store CDs in their cases to protect them from dust, scratches, and warping.

Do not place or store CDs in the following places

- Locations exposed to direct sunlight
- Humid or dusty locations
- Locations directly exposed to a heat vent or heating appliance
- In the glove compartment or on the rear deck of an automobile

Concerning cassette tapes

Selection of cassette tapes

Tapes can get caught on the capstans. Use caution with the following types of tapes.

Cassette tapes exceeding 100 minutes

Tapes are made of a thin film material. Do not repeatedly advance and stop the tape, fast-forward it or rewind it.

Endless-tapes

For this unit, it is recommended to use tapes which are appropriate to the auto reverse mechanism.

Always read the instructions provided with your tapes.

E Tape slack

Tape slack may cause the tape to break.

F Erasure prevention

Use a screwdriver or similar object to break out the tab.

To re-record on a protected cassette

Cover the hole with adhesive tape.
Do not cover the detection hole on hi-position tapes.

Storage precautions

Do not place or store tapes in the following places;

- In high temperature (35°C or higher) or high humidity (80% or higher) areas
- In a strong magnetic field (near a speaker, on top of a TV, etc.) This can erase a recording.
- Locations exposed to direct sunlight

Troubleshooting guide

Before requesting service for this unit, check the chart below for a possible cause of the problem you are experiencing. Some simple checks or a minor adjustment on your part may eliminate the problem and restore proper operation.

If you are in doubt about some of the check points, or if the remedies indicated in the chart do not solve the problem, refer to the directory of Authorized Service Centers (enclosed with this unit) to locate a convenient service center, or consult your dealer for instructions.

For detailed instructions, contact an authorized servicenter in the U.S.A. and Panasonic Canada Inc. Customer Care Centre in Canada.

In the U.S.A. 1-800-211-7262 or web site

(<http://www.panasonic.com>)

In Canada 905-624-5505 or web site (www.panasonic.ca)

Problem	Probable cause(s)	Suggested remedy	Reference page(s)
Problems common to all systems			
ECO mode is on but the display panel still lights up.	DEMO mode is on.	Turn DEMO mode off.	12
The location of the various musical instruments is not well defined.	The (+) and (-) connections to one of the speakers are reversed.	Connect the speaker cords correctly.	7
The left and right sounds are reversed.	The left and right connections to the speaker are reversed.	Connect the speaker cords correctly.	7
LOW frequency sounds cannot be heard.	Either the left or the right LOW speaker cable is not connected.	Connect the left and right speaker cables to the LOW terminals.	7
When listening to the external unit, the left and right sounds are reversed.	The left and right connections to the external unit are reversed.	Connect the external unit's cord correctly.	9
There is no sound when a source is being played.	The (+) and (-) wire of the speaker cords are shorted.	Switch the system to the standby mode, and reconnect the speaker cords so that they are not shorted. Then switch on the power.	7
"ERROR" message appears on the display.	Incorrect operation has been done.	Operate the unit correctly by following the operating instructions.	—
"---:--" appears on the display.	<ul style="list-style-type: none"> • You plugged the power cord in for the first time. • There was a power failure recently. 	Set the time.	13
"F61" appears on the display.	Check if the speaker cords have shorted.	If they are not shorted then there is a power supply problem. Consult your dealer for assistance.	—
While listening to FM broadcasts			
There is a "rushing noise" during a stereo broadcast which is not audible during a monaural broadcast.	The transmitting station is distant.	If you are using an indoor antenna, change to an outdoor antenna.	8
You hear excessive noise during a stereo broadcast, and occasionally the sound disappears.	The installation location and orientation of the antenna are unsuitable.		
The stereo indicator ("ST") flickers and does not light completely.	The transmitting station is distant.	Try switching off the TV set or VCR.	—
	The power of the TV set or VCR is ON.		
The sound during a stereo broadcast is highly distorted.	There is a building or mountain nearby. [Distortion is caused by interference between the signal from the transmitting station (direct wave) and the signal reflected from the building or mountain (reflected wave).]	Use a high-grade outdoor antenna, and install it in a good location, height, and orientation for reception.	8
While listening to AM broadcasts			
You hear an unusual beat sound.	You are using the system at the same time you are playing a TV set.	Switch off the TV set, or use the system further away from it.	—
You hear a low-frequency hum.	The antenna wire is near the power cord.	Separate the antenna wire from the power cord.	—

Problem	Probable cause(s)	Suggested remedy	Reference page(s)
When there is a television set nearby			
The picture on the TV disappears or stripes appear on the screen.	The location and orientation of the antenna are incorrect.	If you are using an indoor antenna, change to an outdoor antenna.	8
	The wiring at the back of the system is unsuitable.	Separate the antenna wire of the TV set from the system.	—
When listening to tapes			
Sound is low, intermittent, poor quality, noisy, scratchy, or unsteady.	Heads are dirty.	Clean the heads.	43
The deck does not enter the recording mode.	The erase-prevention tabs have been removed from the cassette.	Attach tape to cover the space left by removal of the erase-prevention tabs.	41
While listening to compact discs			
The display does not show the correct indication. Disc play does not start when you press the play button.	The disc is upside down.	Set the disc with the label facing upward.	16
	The disc is dirty.	Wipe the disc with a soft cloth.	41
	The disc is scratched.	Replace the disc with a new one.	—
	The disc is badly warped.		
	The disc is a nonstandard one.	Replace the disc with a different one.	41
There is condensation inside the CD changer.	Wait for 60 minutes before using the CDs.	—	
A certain music passage can't be played correctly.	The disc is dirty.	Wipe the disc with a soft cloth.	41
"TAKE OUT DISC" appears on the display.	There is a problem with the CD mechanism. (A power failure may have occurred.)	The tray will open automatically. Remove the CD from the tray, and after ensuring there is no CD in the tray close it. The unit will make the disc changing noises for a few moments and then it should operate normally.	—
While using the remote control			
The system cannot be operated with the remote control.	The batteries are installed in the reverse polarity.	Re-insert the batteries observing the correct polarity.	5
	The batteries are run-down.	Replace the batteries with new batteries.	5

Maintenance

If the surfaces are dirty

To clean this unit, wipe with a soft, dry cloth. If the surfaces are extremely dirty, use a soft cloth dipped in a soap-and-water solution or a weak detergent solution.

Never use alcohol, paint thinner or benzine to clean this unit. Before using chemically treated cloth, read the instructions that came with the cloth carefully.

For a cleaner crisper sound

Clean the heads regularly to assure good quality playback and recording. Use a cleaning tape (not included).

Specifications

AMPLIFIER SECTION

Front speaker power output	
RMS power output	
THD 1.0% , both channels driven	
55 Hz-120 Hz	100 W per channel (6Ω)
120 Hz-4 kHz	30 W per channel (6Ω)
4 kHz-15 kHz	30 W per channel (6Ω)
Total tri-amp power	160 W per channel

Power output in	
Dolby Pro Logic mode	
RMS power output	
THD 1.0% both channels	
Front 55 Hz-120 Hz	100 W per channel (6Ω)
Front 120 Hz-15 kHz	30 W per channel (6Ω)
Center 1kHz	70 W per channel (8Ω)
Surround 1kHz	35 W per channel (8Ω)
Total power output	400 W
Input sensitivity	
AUX 1, AUX 2	250 mV
Input Impedance	
AUX 1, AUX 2	10 kΩ

FM TUNER SECTION

Frequency range	
87.9 - 107.9 MHz (200 kHz step)	
87.5 - 108.0 MHz (100 kHz step)	
Sensitivity	1.8 μV (IHF)
S/N 26 dB	1.5 μV
Antenna terminal(s)	75Ω (unbalanced)

AM TUNER SECTION

Frequency range	520 - 1710 kHz (10 kHz step)
Sensitivity	
S/N 20 dB	500 μV/m

CASSETTE DECK SECTION

Track system	4 track, 2 channel
Heads	
Record/playback	Solid permalloy head
Erasure	Double gap ferrite head
Motor	DC servo motor
Recording system	AC bias 100 kHz
Erasing system	AC erase 100 kHz
Tape speed	4.8 cm/s (1 ⁷ / ₈ ips)
Overall frequency response	
(+3, -6 dB at DECK OUT)	
NORMAL (TYPE I)	35 Hz - 14 kHz
HIGH (TYPE II)	35 Hz - 14 kHz
S/N	50 dB (A weight)
Wow and flutter	0.18% (WRMS)
Fast forward and rewind times	
Approx. 120 seconds with C-60 cassette tape	

CD SECTION

Sampling frequency	44.1 kHz
Decoding	16 bit linear
Frequency response	20 Hz - 20 kHz (+1, -2 dB)
Wow and flutter	Below measurable limit
Digital filter	8 fs
D/A converter	MASH (1 bit DAC)

SPEAKER SECTION

• Front speakers (SB-AK78)	
Type	4 way speaker system
Speaker(s)	
Super woofer	17 cm (6 ¹ / ₁₆ ") cone type
Woofer	12 cm (4 ² / ₃₂ ") cone type
Tweeter	6 cm (2 ³ / ₈ ") ring shaped dome type
Super tweeter	Piezo type
Impedance	
HIGH	6Ω
MID	6Ω
LOW	6Ω
Input power	
HIGH	60W (Music)
MID	60W (Music)
LOW	200 W (Music)
Output sound pressure level	87 dB/W (1.0 m)
Cross over frequency	150 Hz, 3.5 kHz
Frequency range	40 Hz - 50 kHz (-16 dB)
	50 Hz - 36 kHz (-10 dB)
Dimensions (WxHxD)	250x348x292 mm
	(9 ²⁷ / ₃₂ " x 13 ¹¹ / ₁₆ " x 11 ¹ / ₂ ")
Weight	5.6 kg (12.3 lb.)

• Surround speakers (SB-PS70)

Type	1 way, 1 speaker
Speaker	
Full range	8 cm (3 ¹ / ₈ ") cone type
Impedance	8Ω
Input power	60 W (Music)
Output sound pressure level	84 dB/W (1.0 m)
Frequency range	120 Hz - 20 kHz (-16 dB)
Dimensions (WxHxD)	170x106x118 mm
	(6 ¹¹ / ₁₆ " x 4 ³ / ₁₆ " x 4 ²¹ / ₃₂ ")
Weight	0.9 kg (2.0 lb.)

• Center speaker (SB-PC70)

Type	2 way, 2 speaker
Speaker	
Woofer	10 cm (4") cone type
Tweeter	6 cm (2 ³ / ₈ ") cone type
Impedance	8Ω
Input power	120 W (Music)
Output sound pressure level	85 dB/W (1.0 m)
Cross over frequency	4 kHz
Frequency range	75 Hz - 22 kHz (-16 dB)
Dimensions (WxHxD)	250x121x147 mm
	(9 ²⁷ / ₃₂ " x 4 ³ / ₄ " x 5 ²⁵ / ₃₂ ")
Weight	1.6 kg (3.5 lb.)

GENERAL

Power supply	AC 120 V, 60 Hz
Power consumption	230 W
Standby	
Normal mode	13.5 W
Eco mode	0.25 W
Dimensions (WxHxD)	270x330x339 mm
	(10 ⁵ / ₈ " x 13" x 13 ¹ / ₃₂ ")
Weight	9.2 kg (20.2 lb.)

Power consumption in standby mode

Eco mode on	0.25 W
Eco mode off	13.5 W

Notes

1. Specifications are subject to change without notice.
Weight and dimensions are approximate.
2. Total harmonic distortion is measured by the digital spectrum analyzer.

Product service

Do not attempt to remove the cover(s) or repair the unit yourself. Refer servicing to qualified personnel only.
The servicer will require all components to service your system. Therefore, should service ever be necessary, be sure to bring the entire system.

Product information

For product service, product information or assistance with product operation, refer to the servicer directory.

Panasonic Consumer Electronics
Company, Division of Matsushita
Electric Corporation of America
One Panasonic Way Secaucus,
New Jersey 07094
<http://www.panasonic.com>

Panasonic Sales Company,
Division of Matsushita Electric of
Puerto Rico, Inc. ("PSC")
Ave. 65 de Infantería, Km. 9.5
San Gabriel Industrial Park, Carolina,
Puerto Rico 00985

Panasonic Canada Inc. 
5770 Ambler Drive,
Mississauga, Ontario
L4W 2T3
www.panasonic.ca