

SEARS

OWNER'S
MANUAL

MODEL NO.
315.277160

CAUTION:
Read and follow
ALL safety rules
and instructions
before operating
this equipment.

SAVE THIS
MANUAL FOR
FUTURE REFERENCE

Thank You for Buying
Craftsman Tools



CRAFTSMAN[®] Industrial Planer DOUBLE INSULATED

Rules for Safe Operation
Warranty
Operation
Maintenance
Repair Parts



Sold by SEARS, ROEBUCK AND CO., Hoffman Estates, IL 60179 U.S.A.

RULES FOR SAFE OPERATION

DOUBLE INSULATION is a safety concept in electric power tools which eliminates the need for the usual three wire grounded power cord and grounded supply system. Wherever there is electric current in the tool there are two complete sets of insulation to protect the user. All exposed metal parts are isolated from internal metal motor components with protecting insulation.

IMPORTANT - Servicing of a tool with double insulation requires extreme care and knowledge of the system and should be performed only by a qualified service technician. For service we suggest you return the tool to your nearest Sears Store for repair. Always use original factory replacement parts when servicing.

WARNING:

The double insulated system is intended to protect the user from shock resulting from a break in the tool's internal wiring. Observe all normal safety precautions related to avoiding electrical shock.

WARNING:

Do not attempt to operate this tool until you have read thoroughly and understand completely all instructions, safety rules, etc. contained in this manual. Failure to comply can result in accidents involving fire, electric shock, or serious personal injury. Save owner's manual and review frequently for continuing safe operation, and instructing others who may use this tool.

READ ALL INSTRUCTIONS

1. **KNOW YOUR POWER TOOL.** Read owner's manual carefully. Learn its applications and limitations as well as the specific potential hazards related to this tool.
2. **GUARD AGAINST ELECTRICAL SHOCK** by preventing body contact with grounded surfaces. For example: Pipes, radiators, ranges, refrigerator enclosures.
3. **KEEP GUARDS IN PLACE** and in working order.
4. **KEEP WORK AREA CLEAN.** Cluttered areas and benches invite accidents.
5. **AVOID DANGEROUS ENVIRONMENT.** Don't use power tool in damp or wet locations or expose to rain. Keep work area well lit.
6. **KEEP CHILDREN AND VISITORS AWAY.** All visitors should wear safety glasses and be kept a safe distance from work area. Do not let visitors contact tool or extension cord.
7. **STORE IDLE TOOLS.** When not in use tools should be stored in a dry and high or locked-up place - out of the reach of children.
8. **DON'T FORCE TOOL.** It will do the job better and safer at the rate for which it was designed.
9. **USE RIGHT TOOL.** Don't force small tool or attachment to do the job of a heavy duty tool. Don't use tool for purpose not intended - for example - A circular saw should never be used for cutting tree limbs or logs.
10. **WEAR PROPER APPAREL.** Do not wear loose clothing or jewelry that can get caught in tool's moving parts and cause personal injury. Rubber gloves and non-skid footwear are recommended when working outdoors. Wear protective hair covering to contain long hair and keep it from being drawn into nearby air vents.
11. **ALWAYS WEAR SAFETY GLASSES.** Everyday eyeglasses have only impact-resistant lenses; they are **NOT** safety glasses.
12. **PROTECT YOUR LUNGS.** Wear a face mask or dust mask if operation is dusty.
13. **PROTECT YOUR HEARING.** Wear hearing protection during extended periods of operation.
14. **DON'T ABUSE CORD.** Never carry tool by cord or yank it to disconnect from receptacle. Keep cord from heat, oil and sharp edges.
15. **SECURE WORK.** Use clamps or a vise to hold work. Both hands are needed to operate the tool.
16. **DON'T OVERREACH.** Keep proper footing and balance at all times. Do not use on a ladder or unstable support.
17. **MAINTAIN TOOLS WITH CARE.** Keep tools sharp at all times, and clean for best and safest performance. Follow instructions for lubricating and changing accessories.



Look for this symbol to point out important safety precautions. It means attention!!! Your safety is involved.

RULES FOR SAFE OPERATION (Continued)

18. **DISCONNECT TOOLS.** When not in use, before servicing, or when changing attachments, blades, bits, cutters, etc., all tools should be disconnected from power supply.
19. **REMOVE ADJUSTING KEYS AND WRENCHES.** Form habit of checking to see that keys and adjusting wrenches are removed from tool before turning it on.
20. **AVOID ACCIDENTAL STARTING.** Don't carry plugged-in tools with finger on switch. Be sure switch is off when plugging in.
21. **MAKE SURE YOUR EXTENSION CORD IS IN GOOD CONDITION.** When using an extension cord, be sure to use one heavy enough to carry the current your product will draw. An undersized cord will cause a drop in line voltage resulting in loss of power and overheating. A wire gage size (A.W.G.) of at least 16 is recommended for an extension cord 100 feet or less in length. A cord exceeding 100 feet is not recommended. If in doubt, use the next heavier gage. The smaller the gage number, the heavier the cord.
22. **OUTDOOR USE EXTENSION CORDS.** When tool is used outdoors, use only extension cords suitable for use outdoors. Outdoor approved cords are marked with the suffix W-A, for example - SJTW-A or SJOW-A.
23. **KEEP BLADES CLEAN AND SHARP.** Sharp blades minimize stalling and kickback.
24. **KEEP HANDS AWAY FROM PLANING AREA.** Keep hands away from blades. Do not reach underneath work while blades are rotating. Do not attempt to remove material while blades are rotating. Blades continue to rotate after releasing of switch trigger.
25. **NEVER USE IN AN EXPLOSIVE ATMOSPHERE.** Normal sparking of the motor could ignite fumes.
26. **INSPECT TOOL CORDS PERIODICALLY** and if damaged, have repaired at your nearest Sears Repair Center. Stay constantly aware of cord location.
27. **INSPECT EXTENSION CORDS PERIODICALLY** and replace if damaged.
28. **KEEP HANDLES DRY, CLEAN, AND FREE FROM OIL AND GREASE.** Always use a clean cloth when cleaning. Never use brake fluids, gasoline, petroleum-based products or any strong solvents to clean your tool.
29. **STAY ALERT.** Watch what you are doing and use common sense. Do not operate tool when you are tired. Do not rush.
30. **CHECK DAMAGED PARTS.** Before further use of the tool, a guard or other part that is damaged should be carefully checked to determine that it will operate properly and perform its intended function. Check for alignment of moving parts, binding of moving parts, breakage of parts, mounting, and any other conditions that may affect its operation. A guard or other part that is damaged should be properly repaired or replaced by an authorized service center unless indicated elsewhere in this instruction manual.
31. **DO NOT USE TOOL IF SWITCH DOES NOT TURN IT ON AND OFF.** Have defective switches replaced by an authorized service center.
32. **INSPECT FOR** and remove all nails from lumber before cutting.
33. **DRUGS, ALCOHOL, MEDICATION.** Do not operate tool while under the influence of drugs, alcohol, or any medication.
34. **WHEN SERVICING USE ONLY IDENTICAL CRAFTSMAN REPLACEMENT PARTS.**
35. **POLARIZED PLUGS.** To reduce the risk of electric shock, this tool has a polarized plug (one blade is wider than the other). This plug will fit in a polarized outlet only one way. If the plug does not fit fully in the outlet, reverse the plug. If it still does not fit, contact a qualified electrician to install the proper outlet. Do not change the plug in any way.
36. **SAVE THESE INSTRUCTIONS.** Review them frequently and use them to instruct others who may use this tool. If you loan someone this tool, loan them these instructions also.



WARNING:

Some dust created by power sanding, sawing, grinding, drilling, and other construction activities contains chemicals known to cause cancer, birth defects or other reproductive harm. Some examples of these chemicals are:

- lead from lead-based paints,
- crystalline silica from bricks and cement and other masonry products, and
- arsenic and chromium from chemically-treated lumber.

Your risk from these exposures varies, depending on how often you do this type of work. To reduce your exposure to these chemicals: work in a well ventilated area, and work with approved safety equipment, such as those dust masks that are specially designed to filter out microscopic particles.

INTRODUCTION

CONGRATULATIONS AND THANK YOU FOR BUYING THIS CRAFTSMAN INDUSTRIAL PLANER. It has been designed, engineered and manufactured to provide you with Sears high standard of dependability, ease of operation, and operator safety. Properly cared for, it will give you years of rugged, trouble-free performance.

SPECIFICATIONS:

Cutting Width	3-5/8 Inches
Depth Of Cut	0-1/16 Inch
Horsepower	3/4
Rating	120 Volts, 60 Hz, AC only, 5.5 AMPS
No Load Speed	16,000 RPM / 32,000 CPM
Reversible Cutter Blades	



CAUTION:

Carefully read through this entire owner's manual before using your new planer. Pay close attention to the Rules For Safe Operation, Warnings and Cautions. If you use your planer properly and only for what it is intended, you will enjoy years of safe, reliable service.

Your planer has many features for making cutting operations more pleasant and enjoyable. Safety, performance and dependability have been given top priority in the design of this planer making it easy to maintain and operate.

FULL ONE YEAR WARRANTY ON CRAFTSMAN INDUSTRIAL PLANER

If this Craftsman Industrial Planer fails due to a defect in material or workmanship within one year from the date of purchase, Sears will repair it, free of charge.

WARRANTY SERVICE IS AVAILABLE BY SIMPLY RETURNING THE TOOL TO THE NEAREST SEARS STORE IN THE UNITED STATES.

This warranty gives you specific legal rights, and you may also have other rights which vary from state to state.

Sears, Roebuck and Co., DEPT. 817 WA, Hoffman Estates, IL 60179

TABLE OF CONTENTS

1. Rules for Safe Operation	2-3
2. Introduction and Product Specifications	4
3. Warranty and Table Of Contents	4
4. Operation	5-9
5. Accessories	9
6. Maintenance	10-13
7. Exploded View and Repair Parts List	14-15
8. Parts Ordering / Service	16



WARNING:



The operation of any planer can result in foreign objects being thrown into your eyes, which can result in severe eye damage. Before beginning power tool operation, always wear safety goggles or safety glasses with side shields and a full face shield when needed. We recommend Wide Vision Safety Mask for use over eyeglasses or standard safety glasses with side shields, available at Sears Retail Stores.

OPERATION

WARNING:

Always wear safety goggles or safety glasses with side shields when operating your planer. Failure to do so could result in dust, shavings, loose particles or foreign objects being thrown into your eyes, causing possible serious injury.

KNOW YOUR PLANER

Before attempting to use your planer, familiarize yourself with all operating features and safety requirements. See *Figure 1*.

Your planer is compact, lightweight, and equipped with a depth adjusting knob located at the front of your unit.

When used properly, your planer should take the guesswork out of planing, sizing, or beveling of doors, windows, shutters, drawer slides, and other work. However, as with any powerful, high-speed tool, your planer requires accurate set-ups and handling. Practice cutting on scrap lumber before attempting to plane finished stock. In order to turn out the quality work for which your tool has been designed, the importance of the need for you to practice cannot be over-emphasized.

SWITCH

To turn your planer **ON**, depress switch trigger. Release switch trigger to turn your planer **OFF**. See *Figure 1*.

WARNING:

If any parts are missing, do not operate your planer until the missing parts are replaced. Failure to do so could result in possible serious personal injury.

ELECTRICAL CONNECTION

Your planer has a precision built electric motor. It should be connected to a **power supply that is 120 volts, 60 Hz, AC only (normal household current)**. Do not operate this tool on direct current (DC). A voltage drop of more than 10 percent will cause a loss of power and the motor will overheat. If your tool does not operate when plugged into an outlet, double-check the power supply.

WARNING:

Do not allow familiarity with your planer to make you careless. Remember that a careless fraction of a second is sufficient to inflict severe injury.

CHIP EXHAUST

A chip exhaust has been provided on the exhaust port of your planer. The chute on the chip exhaust can be rotated 90° with positive stops at 0°, 30°, 60° and 90° for deflecting wood chips away from the operator and workpiece.

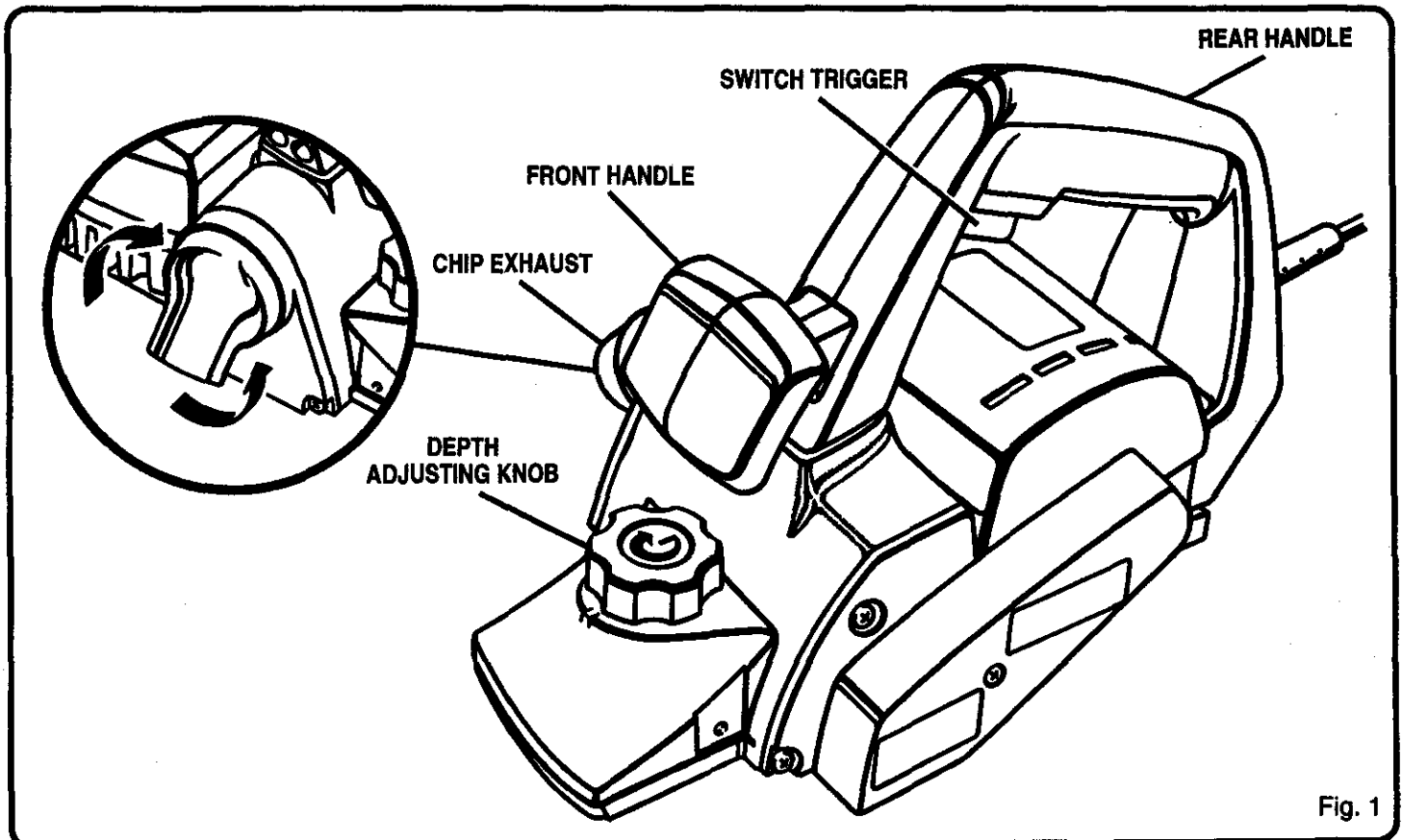

Fig. 1

OPERATION

WARNING:

Your planer should never be connected to power supply when you are assembling parts, making adjustments, changing belts or blades, when cleaning, or when not in use. Disconnecting your planer will prevent accidental starting that could cause serious injury.

PREPARING FOR OPERATION

See Figure 1.

For ease of operation your planer has both a front handle and a rear handle. This provides for two-hand operation, which is necessary in order to maintain proper control of your planer and keep both hands clear of the blades and cutting area. When operating your planer always use both hands holding the front handle with your left hand and the rear handle with your right hand as shown in figure 2. In this position, your planer is easier to handle and you are clear of the chip exhaust.

CAUTION:

Planing too fast increases chip build-up in the chip exhaust. Chip build-up restricts air flow and can cause motor overheating.

Keep cord away from cutting area. **ALWAYS** place the cord to prevent it from hanging on the work while making a cut.

DANGER:

If the cord hangs up on the work during a cut, release the switch trigger immediately. Unplug your planer and check cord for damage. If no damage, reposition the cord to prevent it from hanging up again. If the cord has been damaged, have it replaced before using your planer.

WARNING:

Using your planer with a damaged cord could cause electrical shock resulting in serious injury.

KNOW THE RIGHT WAY TO USE YOUR PLANER. See Figure 2.

NEVER USE YOUR PLANER AS SHOWN IN FIGURES 3 AND 4.

ALWAYS keep control of your planer. It makes cutting easier and safer. To help keep control, always support your work so the cut will be on your right. Clamp your work so it will not move during the cut. See Figure 2. The work moving during a cut could result in the loss of control of your planer possibly causing serious injury.

ALWAYS operate your planer with the chip exhaust turned away from your face and eyes. All visitors should wear safety glasses and be kept a safe distance from work area.

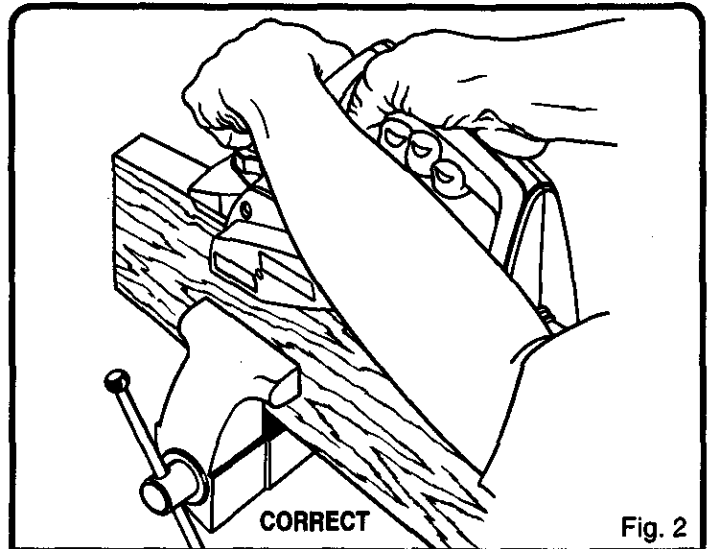

Fig. 2

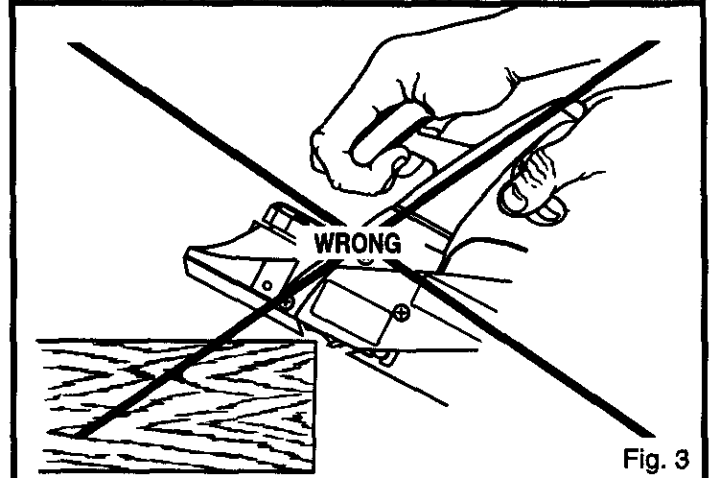

Fig. 3

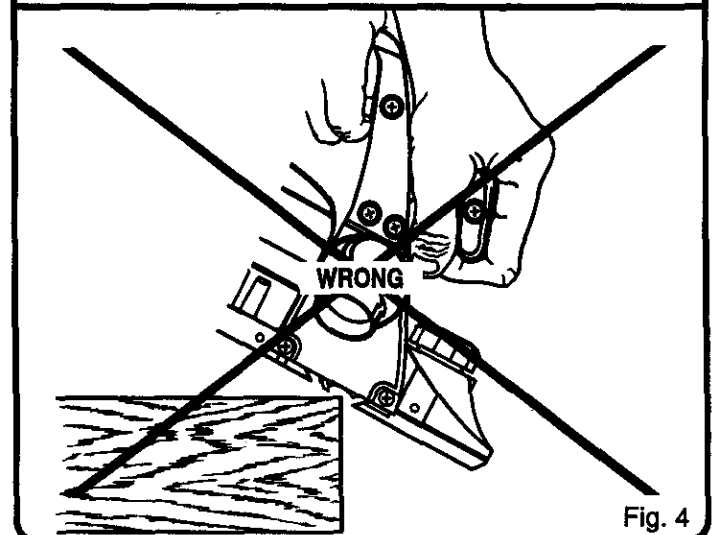

Fig. 4

ALWAYS hold your planer so that the blades do not contact the workpiece before depressing the switch and starting your planer.

WARNING:

Keep a firm grip on the tool with both hands at all times. Failure to do so could result in loss of control leading to possible serious injury.

OPERATION

TO ADJUST PLANING DEPTH

See Figure 5.

UNPLUG YOUR PLANER.



WARNING:

Failure to unplug your planer could result in accidental starting causing serious injury.

Planing depth is adjustable from 0 to 1/16 inch and is adjusted by rotating the depth adjusting knob located on the front of your planer. See Figure 5. To increase cutting depth, rotate knob clockwise. To decrease cutting depth, rotate knob counterclockwise. It is recommended that test cuts be made in scrap wood after each adjustment to make sure that the desired amount of wood is being removed by your planer. **NOTE: TO PROTECT BLADES DURING STORAGE, TRANSPORTING, ETC., SET BLADE DEPTH ADJUSTMENT TO 0.**

GENERAL CUTTING

Adjust your planer to desired depth of cut. **WITH YOUR LEFT HAND HOLDING THE FRONT HANDLE AND YOUR RIGHT HAND HOLDING THE REAR HANDLE**, place front shoe on workpiece. Make sure blades are not touching the work. Apply pressure to the front handle so that the front shoe is flat on the work. Pull switch trigger to start your planer and let the motor reach maximum speed. Hold your planer firmly and push forward steadily into your work. **NOTE:** Push planer forward slowly if a smooth cut is desired. As the end of the planed cut is reached, apply downward pressure toward the rear handle. This will help keep the rear section of the base in contact with the work preventing the front of your planer from dipping or gouging your cut. Be careful to avoid hitting nails during planing operation. This could nick, crack or damage blades. We suggest that you keep an extra set of blades on hand. As soon as the blades in your planer show signs of becoming dull, replace them.

NOTE: THE BLADES IN YOUR PLANER ARE REVERSIBLE. THEREFORE THEY CAN BE ROTATED UNTIL BOTH SIDES BECOME DULL.

EDGE PLANING (CHAMFERING)

See Figure 6.

Your planer has been designed with a groove in the front shoe.

The purpose for this groove is chamfering edges of boards as shown in Figure 6. Practice cutting on scrap lumber to determine the amount to be removed from the board, before making a cut on good lumber. **FIRMLY HOLDING THE FRONT HANDLE WITH YOUR LEFT HAND AND THE REAR HANDLE WITH YOUR RIGHT HAND**, place the groove on the surface to be cut, start your planer and let it reach full speed, then slowly move it into the work. Maintain downward pressure to keep your planer flat at the beginning and the end of the work surface.

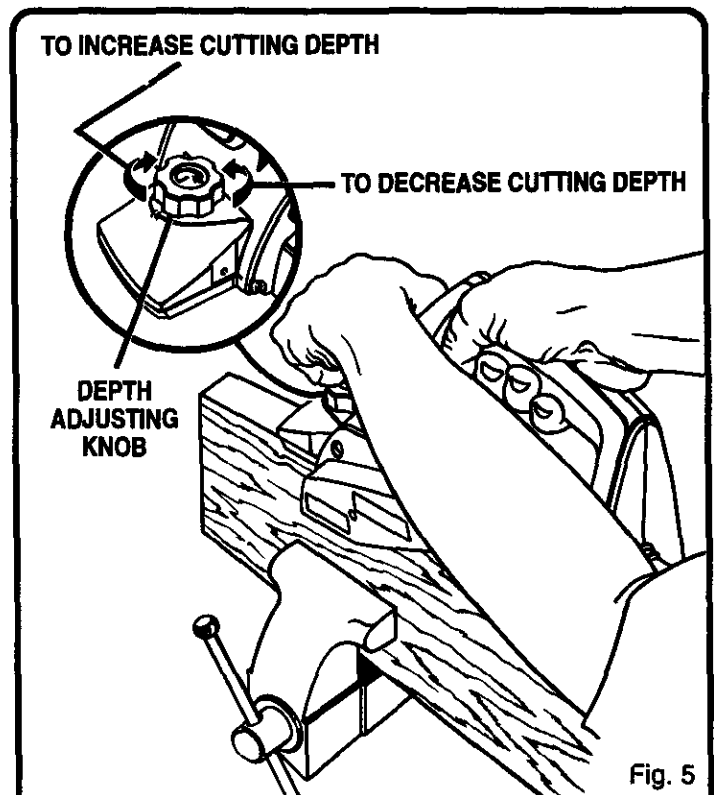

Fig. 5

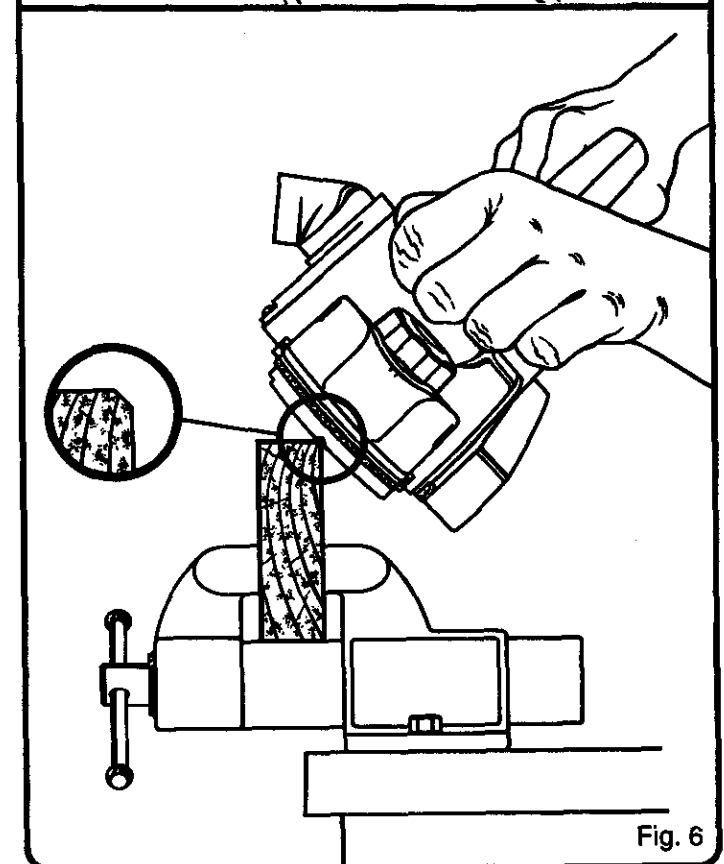

Fig. 6

OPERATION

Packed with your planer to make it a more versatile tool, is an **EDGE GUIDE**, **RABBETING PLATE**, and **DOOR BEVEL FENCE**. See Figures 7, 8, and 9.

EDGE GUIDE

See Figure 7.

The edge guide packed with your planer easily attaches to either side of your planer and is useful when planing long and uneven surface boards. When making cuts using your edge guide, the guide should be held firmly against the edge of the board.

TO ATTACH

1. UNPLUG YOUR PLANER.



WARNING:

Failure to unplug your planer could result in accidental starting causing serious injury.

2. Insert the screw provided through the hole in the edge guide and secure it into screw hole on either side of the main shoe. See Figure 7.

RABBETING PLATE

See Figure 8.

The rabbeting plate packed with your planer attaches to the right side of your planer and can be used to make rabbet cuts up to 3/16 inch deep. The maximum width of cut is 1 1/32 inch per cut.

TO ATTACH

1. UNPLUG YOUR PLANER.



WARNING:

Failure to unplug your planer could result in accidental starting causing serious injury.

2. Insert the screw provided through flat washer, then through the slot in the rabbeting plate.
3. Next, insert screw into screw hole on the right side of the main shoe and tighten securely.

TO ADJUST DEPTH OF RABBET CUT:

1. UNPLUG YOUR PLANER.



WARNING:

Failure to unplug your planer could result in accidental starting causing serious injury.

2. Place your planer on a flat board or workpiece.
3. Loosen screw and position the bottom surface of the rabbeting plate above the board the same distance as the desired depth of cut. See Figure 8.
4. Tighten screw securely.

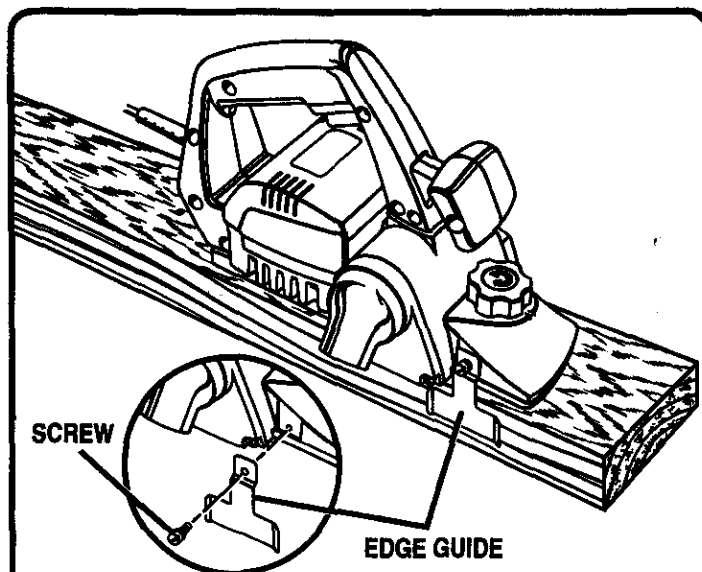

Fig. 7

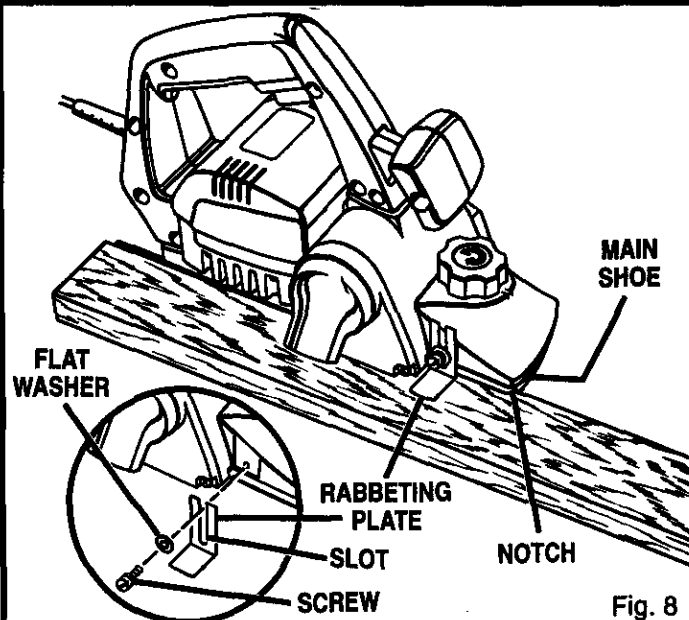

Fig. 8

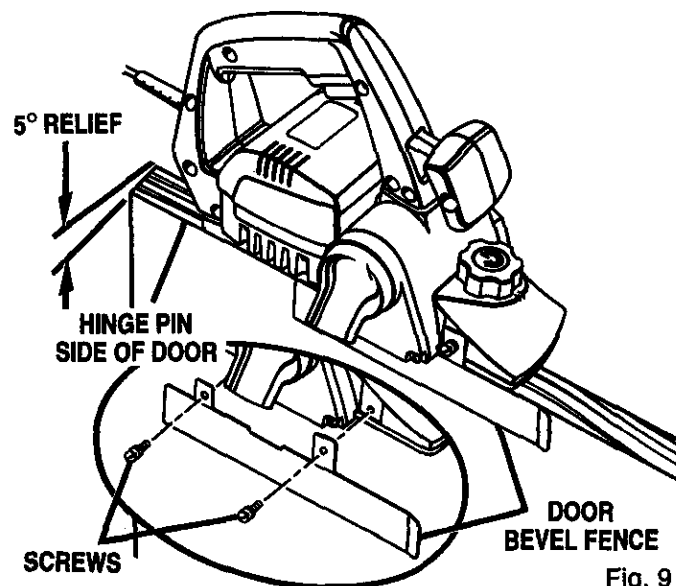

Fig. 9

OPERATION

NOTE: When making a rabbet cut, place the notch located on the inside of the main shoe firmly against the side of the board as shown in figure 8. The rabbeting plate should also be pressed firmly against the top surface of the board.

DOOR BEVEL FENCE

See Figure 9.

The door bevel fence packed with your planer also attaches to the right side of your planer and automatically provides a five degree relief on the edge of a door.

TO ATTACH

1. UNPLUG YOUR PLANER.



WARNING:

Failure to unplug your planer could result in accidental starting causing serious injury.

2. Position door bevel fence as shown in figure 9 and align with screw holes on the right side of main shoe.
3. Insert screws and tighten securely.

Adjust your planer to desired depth of cut. **WITH YOUR LEFT HAND HOLDING THE FRONT HANDLE AND YOUR RIGHT HAND HOLDING THE REAR HANDLE**, place front shoe on workpiece. Make sure blades are not touching the work. Apply pressure so that the door bevel fence is firmly against workpiece, allowing for the desired five degree relief. Pull switch trigger to start your planer and let the motor reach maximum speed. Hold your planer firmly and push forward steadily into your work.

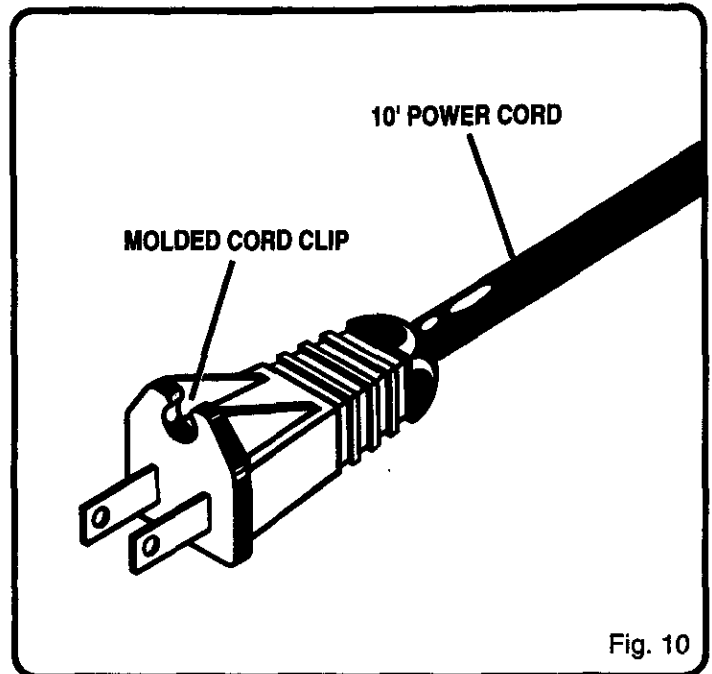

POWER CORD

See Figure 10.

Your planer has a new extra-long 10' power cord that stays soft and flexible in cold weather. The plug design is shaped so that it won't snag on your work during use. A molded cord clip on the plug makes cord storage easier.

ACCESSORIES

THE FOLLOWING RECOMMENDED ACCESSORIES ARE CURRENTLY AVAILABLE AT SEARS RETAIL STORES.

Blades (Item No. 917323)



WARNING: The use of attachments or accessories not listed above might be hazardous.

MAINTENANCE

WARNING:

When servicing use only identical Craftsman replacement parts. Use of any other parts may create a hazard or cause product damage.

GENERAL

Only the parts shown on parts list, page 15, are intended to be repaired or replaced by the customer. All other parts represent an important part of the double insulation system and should be serviced only by a qualified Sears service technician.

Avoid using solvents when cleaning plastic parts. Most plastics are susceptible to various types of commercial solvents and may be damaged by their use. Use clean cloths to remove dirt, carbon dust, etc.

WARNING:

Do not at any time let brake fluids, gasoline, petroleum-based products, penetrating oils, etc. come in contact with plastic parts. They contain chemicals that can damage, weaken, or destroy plastic.

When electric tools are used on fiberglass boats, sports cars, wallboard, spackling compounds, or plaster, it has been found that they are subject to accelerated wear and possible premature failure, as the fiberglass chips and grindings are highly abrasive to bearings, brushes, commutators, etc. Consequently it is not recommended that this tool be used for extended work on any fiberglass material, wallboard, spackling compounds, or plaster. During any use on these materials, it is extremely important that the tool is cleaned frequently by blowing with an air jet.

WARNING:

Always wear safety goggles, or safety glasses with side shields during power tool operation or when blowing dust. If operation is dusty, also wear a dust mask.

EXTENSION CORDS

The use of any extension cord will cause some loss of power. To keep the loss to a minimum and to prevent tool overheating, use an extension cord that is heavy enough to carry the current the tool will draw.

A wire gauge size (A.W.G.) of at least **16** is recommended for an extension cord 100 feet or less in length. When working outdoors, use an extension cord that is suitable for outdoor use. The cord's jacket will be marked **WA**.

CAUTION:

Keep extension cords away from any planing area and position the cord so that it will not get caught on lumber, tools, etc., during planing operation.

WARNING:

Check extension cords before each use. If damaged replace immediately. Never use tool with a damaged cord since touching the damaged area could cause electrical shock resulting in serious injury.

LUBRICATION

All of the bearings in this tool are lubricated with a sufficient amount of high grade lubricant for the life of the unit under normal operating conditions. Therefore, no further lubrication is required.

MAINTENANCE

TIMING BELT REPLACEMENT

1. UNPLUG YOUR PLANER.

WARNING:

Failure to unplug your planer could result in accidental starting causing serious injury.

WHEN REPLACING TIMING BELT, USE RECOMMENDED REPLACEMENT BELT ONLY. See *Parts List, Page 15.*

2. Remove belt cover screw. Then remove the belt cover. See *Figure 11.*
3. Force old belt from small pulley with a screwdriver and remove it from large pulley. If it is worn out, simply cut the old belt and remove it.
4. Install new belt over large pulley first. See *Figure 12.*
5. Holding the belt as shown in figure 12, press the belt onto the small pulley. **NOTE: TO SIMPLIFY THE PROCESS, TURN THE LARGE PULLEY AS YOU PRESS THE BELT ONTO THE SMALL PULLEY.**
6. Reassemble belt cover and screw.

WARNING:

Belt cover is part of the double insulated system. To retain electrical insulation and provide user protection as provided in the original design, never attempt to operate your planer without belt cover and all parts reassembled.

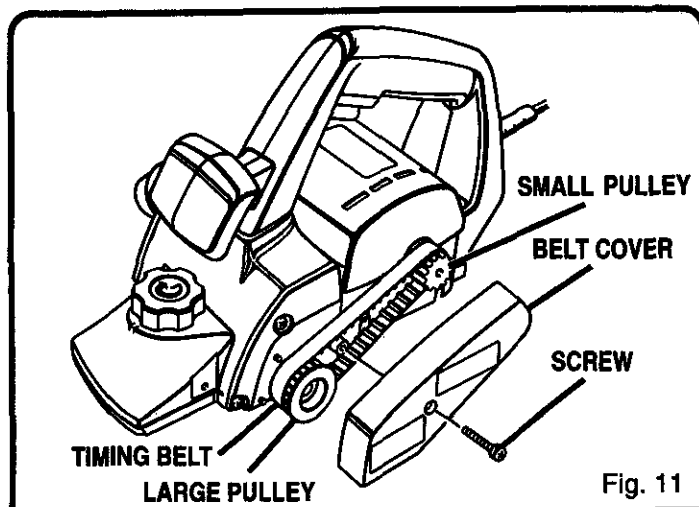

Fig. 11

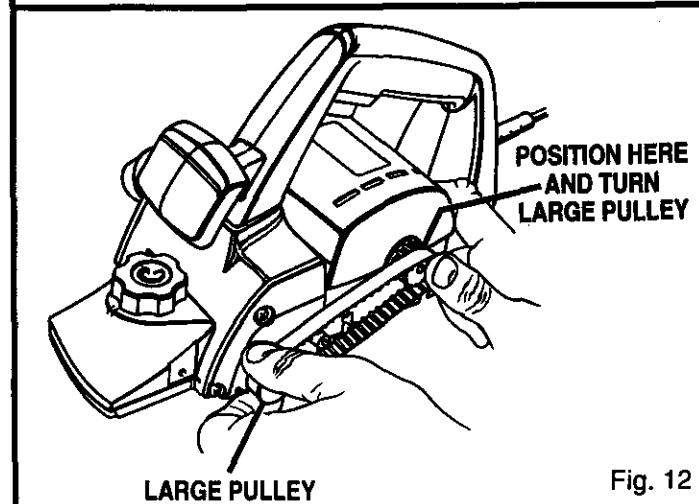

Fig. 12

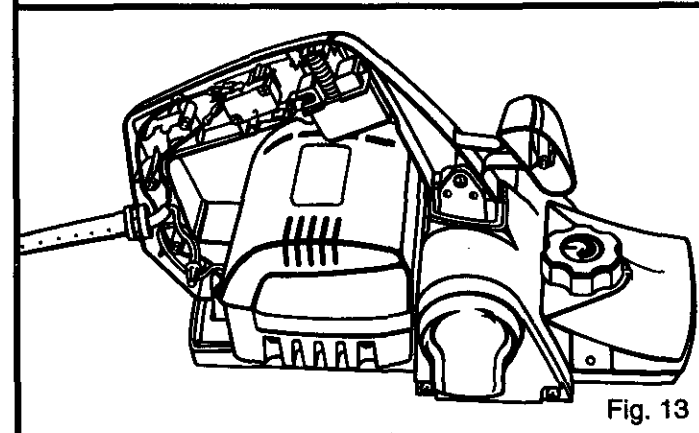

Fig. 13

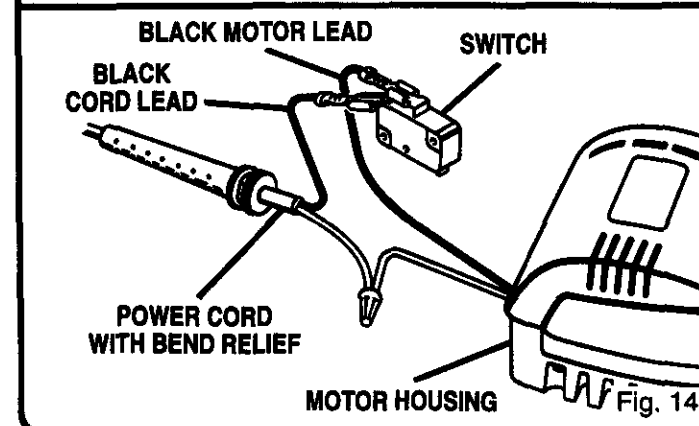

Fig. 14

SWITCH REPLACEMENT

1. UNPLUG YOUR PLANER.

WARNING:

Failure to unplug your planer could result in accidental starting causing serious injury.

2. Remove the eight screws that secure the handle cover and carefully lift it from the tool. Note the exact location of each screw since the screw sizes vary in length.
3. Note the location of all wiring in the handle and where each switch lead connects to the switch terminals. Connections and wiring position must be identical when installing the new switch. See *Figure 13.*
4. Unplug switch leads from the switch. See *Figure 14.*
5. Make lead connections to the new switch by plugging switch leads into switch terminals.
6. Arrange the wiring in the handle so that it will not be pinched or contact screws when handle cover is replaced.
7. Reposition switch on switch posts in the housing.
8. Replace the switch trigger and spring if they have fallen out of housing. Switch trigger fits above lip on housing.
9. Place the cord and bend relief in their correct locations.
10. Replace handle cover and tighten all screws securely.

MAINTENANCE

CORD REPLACEMENT

1. UNPLUG YOUR PLANER.



WARNING:

Failure to unplug your planer could result in accidental starting causing serious injury.

2. Remove the eight screws that secure the handle cover and carefully lift it from your tool. Note the exact location of each screw since the screw sizes vary in length.
3. Note the locations of all wiring in the handle and how each connection is made to the cord. Connections and wiring position must be identical when installing new cord. See Figure 15.
4. Unplug the black cord lead from the switch, then disconnect the white cord lead from the wire nut. See Figure 16.
5. Plug the black cord lead of the new power cord into the switch terminal.
6. Connect the white cord lead to the white motor lead and secure with the wire nut.
7. Arrange the wiring in the handle so that it will not be pinched or contact screws when handle cover is replaced.
8. Reposition switch on switch posts in the housing.
9. Replace the switch trigger and spring if they have fallen out of the housing. Switch trigger fits above the lip on the housing.
10. Place the cord and bend relief in their correct locations.
11. Replace handle cover and screws. Tighten all screws securely.

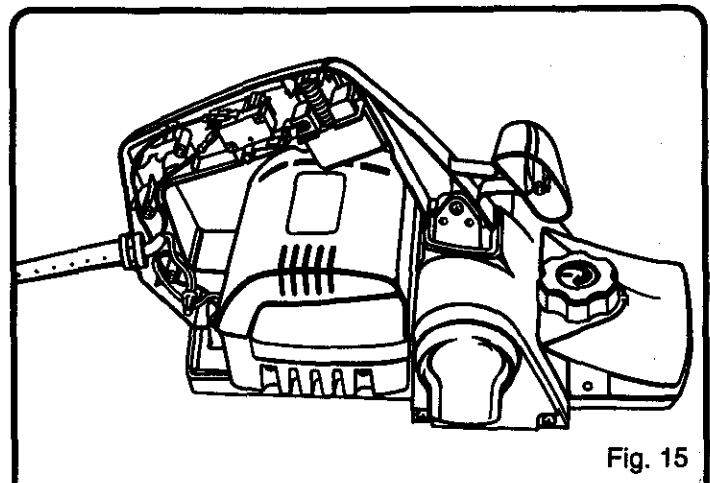

Fig. 15

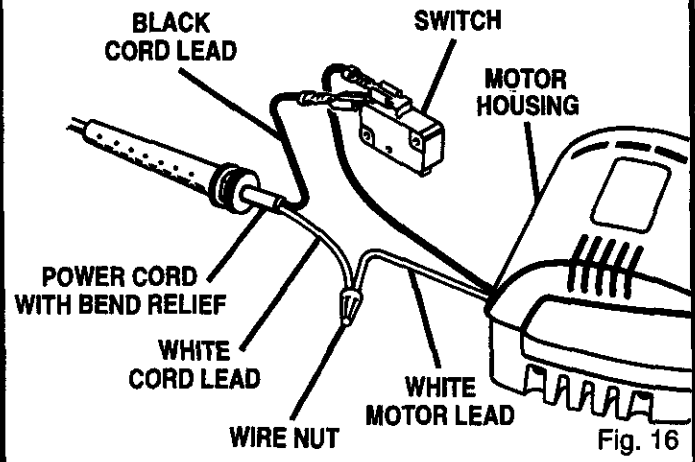

Fig. 16

TO CLEAN CHIP EXHAUST

After using your planer for an extended period of time or when planing wet or green lumber, chips will build-up in the chip exhaust and require cleaning. This chip build-up restricts air flow and causes motor overheating. Clean as follows:

1. UNPLUG YOUR PLANER.



WARNING:

Failure to unplug your planer could result in accidental starting causing serious injury.

2. Remove the two chip shield screws and chip shield. See Figure 17.
3. Clean the chip build-up from the exhaust port on your planer with a dowel pin or small piece of wood. **DO NOT** use your hands or fingers.
4. Clean chips and chip build-up from the chip shield. Clean chip shield with a soft, dry cloth.
5. Replace chip shield and secure with the two chip shield screws.
6. Tighten screws securely.

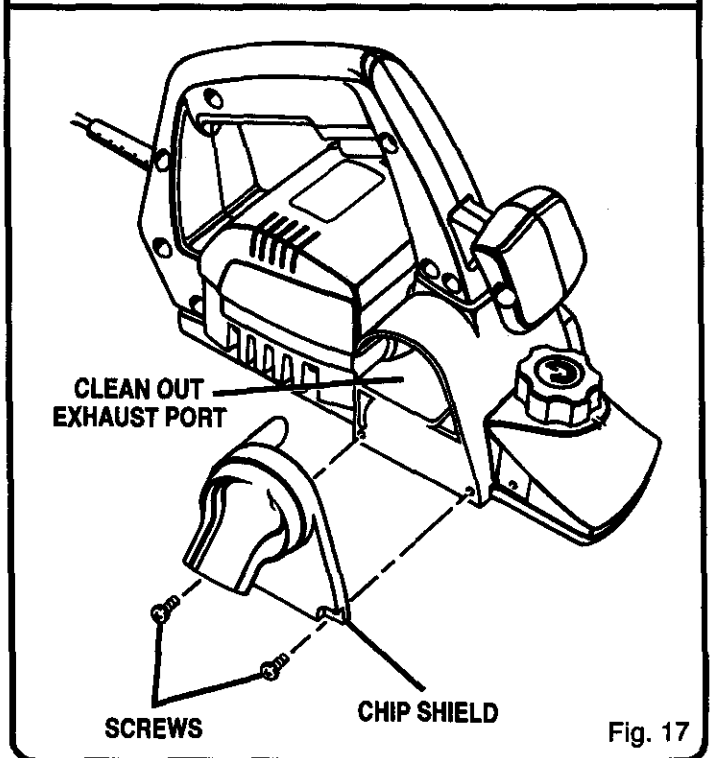

Fig. 17

MAINTENANCE

BLADE REPLACEMENT

The blades in your planer are reversible. Therefore, they can be reversed when one edge becomes dull.

ALWAYS REPLACE OR REVERSE BLADES IN PAIRS.

DO NOT ATTEMPT TO SHARPEN BLADES.

NEVER ATTEMPT TO OPERATE YOUR PLANER WITH ONLY ONE BLADE INSTALLED.

1. UNPLUG YOUR PLANER.



WARNING:

Failure to unplug your planer could result in accidental starting causing serious injury.

2. Place your planer in an upside down position on work bench. *See Figure 18.*

3. To prevent rotation of the arbor while changing the blades, place a small piece of wood between the arbor and the base. *See Figure 18.*



WARNING:

Remove the piece of wood before restarting your planer. Failure to do so could result in the piece of wood being thrown from your planer causing possible serious injury.

4. Using the 5/32 in. allen wrench provided, remove the three (3) screws securing blade. *See Figure 19.*

5. Remove blade clamp and cutter blade.

6. Clean any sawdust or wood particles from cutter arbor and from all parts you have removed.

7. Place new cutter blade over plastic locators. *See Figure 20.* **NOTE:** Place front of cutter blade slots so that they touch plastic locators. Do not move or adjust plastic locators. They have been factory adjusted to assure proper depth setting is maintained and that the blades remain parallel.

8. Replace blade clamp and screws.

9. Securely tighten all screws with allen wrench.

10. Remove the piece of wood from your planer.

11. Repeat the above procedure to change the other blade.

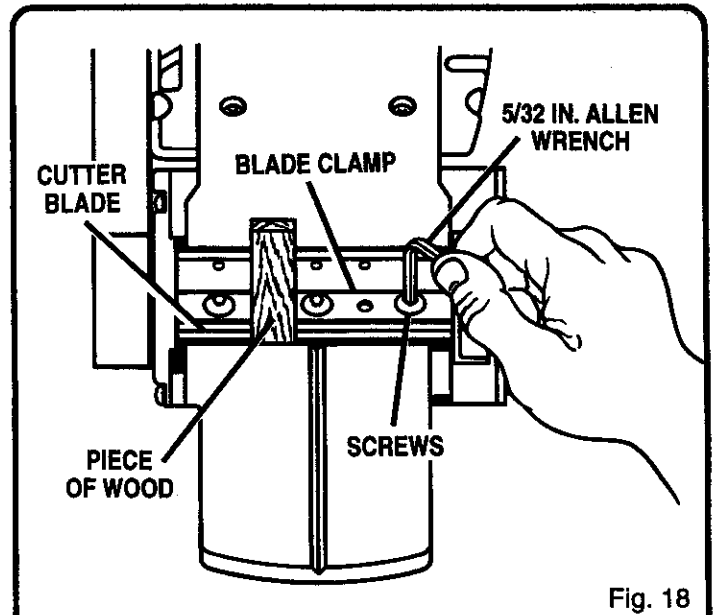

Fig. 18

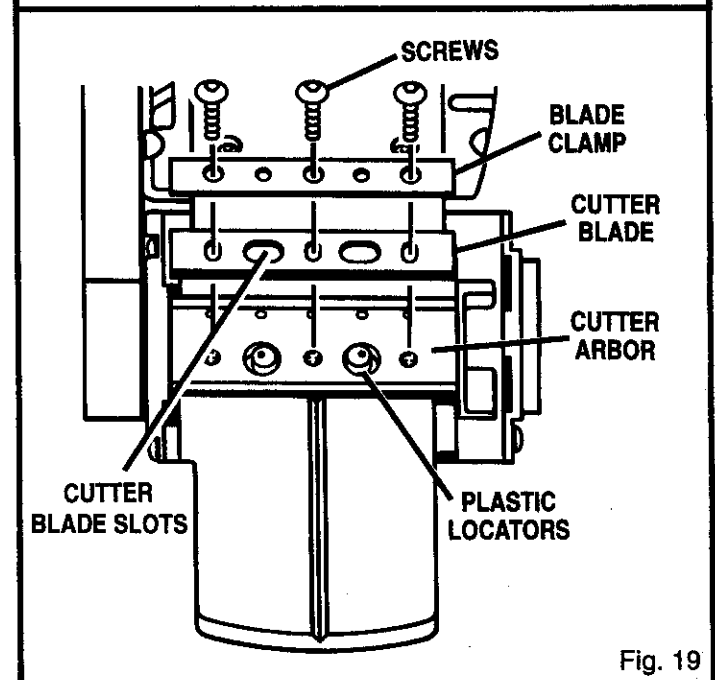

Fig. 19

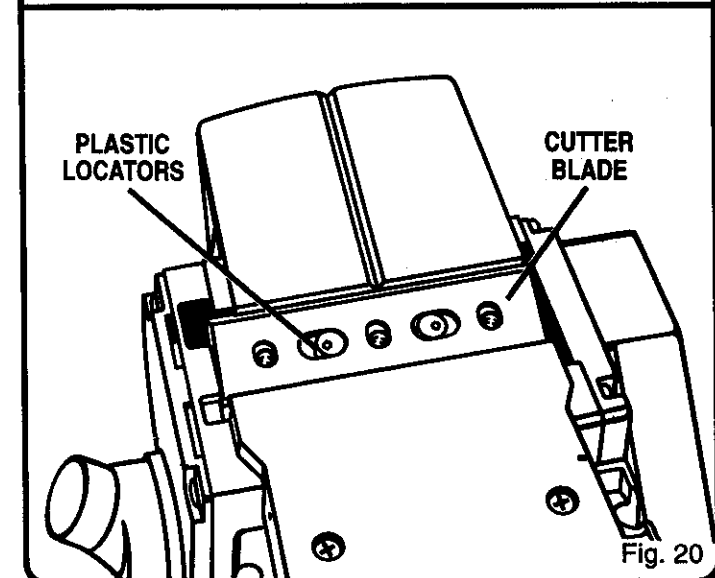
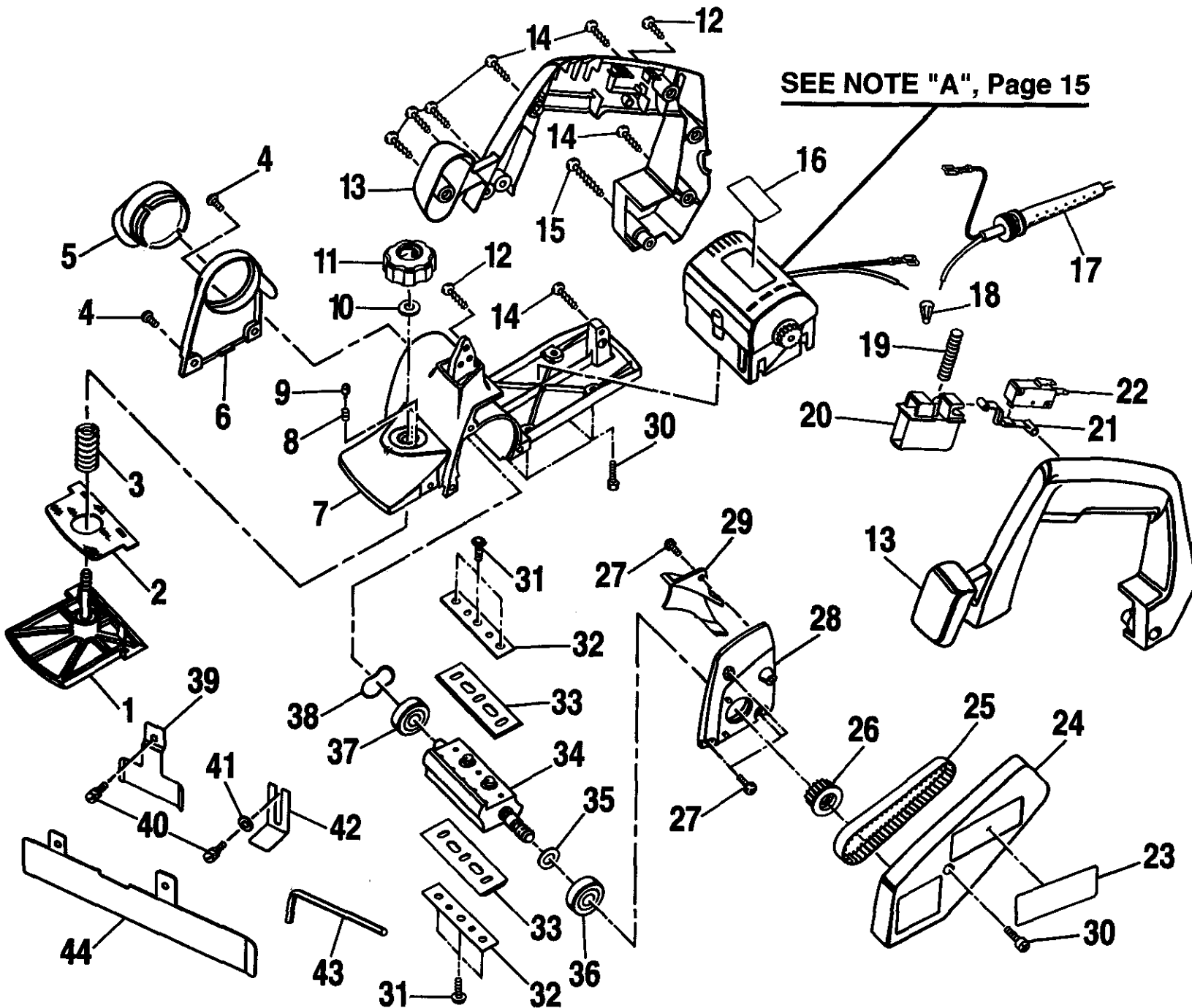

Fig. 20



CRAFTSMAN INDUSTRIAL PLANER — MODEL NUMBER 315.277160

The model number will be found on a plate attached to the motor housing. Always mention the model number in all correspondence regarding your **PLANER** or when ordering repair parts.

SEE BACK PAGE FOR PARTS ORDERING INSTRUCTIONS

PARTS LIST

Key Part No.	Part Number	Description	Quan.	Key Part No.	Part Number	Description	Quan.
1	972482-003	Front Shoe	1	24	606856-004	Belt Cover	1
2	972492-001	Rubber Plate	1	25	973831-001	Timing Belt	1
3	606872-001	Adjustment Spring.....	1	26	607139-002	Pulley	1
4	610122-003	* Screw (#8-32 x 3/8 In. Pan Hd. T.C).....	2	27	622163-010	* Screw (#8-32 x 5/16 In. Pan Hd.)	4
5	972475-001	Chip Exhaust Extension.....	1	28	610183-202	Cutter Head Support	1
6	972474-001	Chip Exhaust.....	1	29	606627-201	Blow Guide.....	1
7	972480-005	Main Shoe	1	30	703432-058	* Screw (#8-32 x 5/8 In. Fil Hd.)	5
8	970627-001	Spring.....	1	31	610878-002	* Screw (#1/4-20 x 1/2 In. Button Hd.)	6
9	970700-001	Detent Button	1	32	999682-003	Blade Clamp	2
10	931744-822	Washer.....	1	33	967039-000	*** Blade (Item No. 9-17323)	1
11	972711-000	Knob With Indicator	1	34	610389-002	Cutter Head Assembly	1
12	617966-028	* Screw (#8-10 x 1/2 In. Pan Hd.)	2	35	706239-836	Washer.....	1
13	972483-000	Handle With Cover.....	1	36	621585-002	Ball Bearing (NTN#6200LLBC3/1E)	1
14	617966-031	* Screw (#8-10 x 3/4 In. Pan Hd.)	7	37	622149-055	Ball Bearing (NTN#629LBZC3/1E)	1
15	617966-015	* Screw (#8-10 x 1 In. Pan Hd.)	1	38	620789-007	Washer.....	1
16	972488-001	Data Plate	1	39	606873-001	Edge Guide	1
17	970777-015	Cord	1	40	621431-008	* Screw (#10-24 x 3/8 In. Fil. Hd.)	2
18	623173-007	Wire Nut	1	41	931744-815	Washer **STD551010.....	1
19	971492-001	Spring.....	1	42	606866-001	Rabbeting Plate	1
20	972481-001	Switch Trigger	1	43	820193-011	* 5/32 In. Hex Socket Key (Item No. 9-28173)	1
21	971474-001	Switch Actuator	1	44	610988-002	Door Bevel Fence	1
22	065501-190	Switch	1		972000-115	Owner's manual	
23	977222-001	Logo Plate.....	1				

NOTE: "A"— The assembly shown represents an important part of the Double Insulated System. To avoid the possibility of alteration or damage to the system, service should be performed by your nearest Sears Repair Center. Contact your nearest Sears Retail Store for Service Center information.

* Standard Hardware Item — May Be Purchased Locally.
 ** Available From Division 98 — Source 980.00
 *** Available At Your Nearest Sears Retail Store.

For repair of major brand appliances **in your own home...**
no matter who made it, no matter who sold it!

1-800-4-MY-HOMESM Anytime, day or night
(1-800-469-4663)

www.sears.com

To bring in products such as vacuums, lawn equipment and electronics
for repair, call for the location of your nearest **Sears Parts & Repair Center.**

1-800-488-1222 Anytime, day or night

www.sears.com

For the replacement parts, accessories and owner's manuals
that you need to do-it-yourself, call **Sears PartsDirectSM!**

1-800-366-PART 6 a.m. – 11 p.m. CST,
(1-800-366-7278) 7 days a week

www.sears.com/partsdirect

To purchase or inquire about a Sears Service Agreement:

1-800-827-6655

7 a.m. – 5 p.m. CST, Mon. – Sat.

Para pedir servicio de reparación a domicilio,
y para ordenar piezas con entrega a domicilio:

1-888-SU-HOGARSM
(1-888-784-6427)

Au Canada pour service en français:

1-877-LE-FOYERSM
(1-877-533-6937)

SEARS
HomeCentralSM