

Operator's Manual

CRAFTSMAN[®]

6¹/₈"

Bench Top

JOINTER/PLANER

Model No.

351.217680

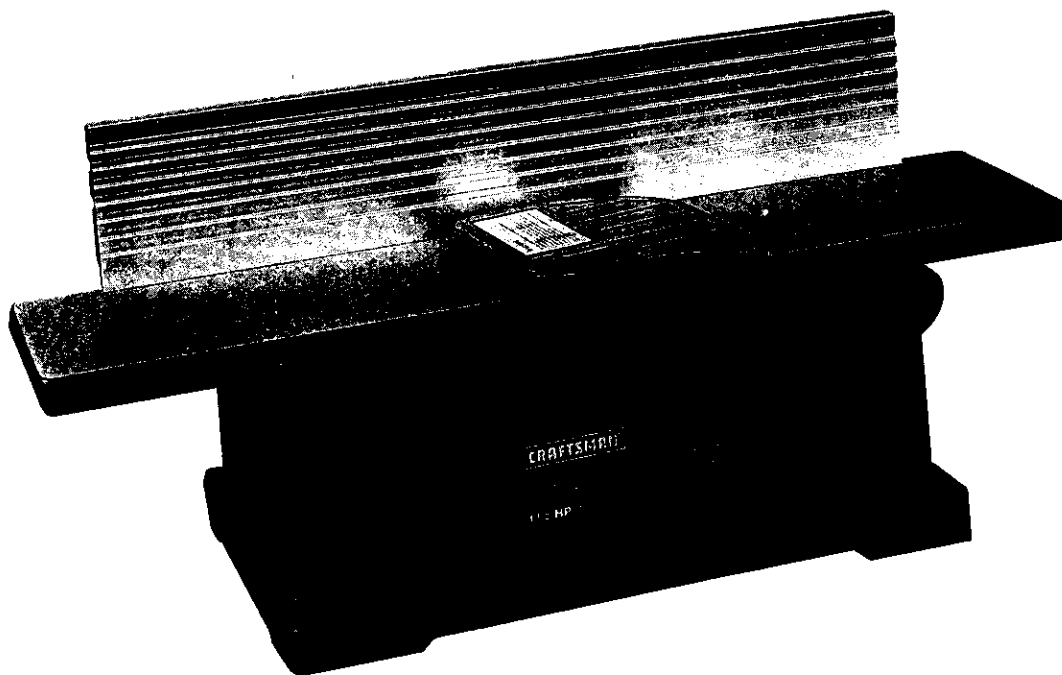

CAUTION: Read and follow all Safety Rules and Operating Instructions before First Use of this Product.

Sears, Roebuck and Co., Hoffman Estates, IL 60179 U.S.A.

16303.00 Draft (01/04/00)

SAFETY

ASSEMBLY

OPERATION

MAINTENANCE

PARTS LIST

ESPAÑOL

TABLE OF CONTENTS

Warranty	2
Safety Rules	2-3
Unpacking	3
Assembly	3
Installation	4-5
Operation	5-9
Maintenance	9-10
Troubleshooting	11
Parts Illustration and List	13-15
Español	16-26

WARRANTY

FULL ONE YEAR WARRANTY

If this product fails due to a defect in material or workmanship within one year from the date of purchase, Sears will at its option repair or replace it free of charge.

Contact your nearest Sears Service Center to arrange for product repair, or return this product to place of purchase for replacement.

If this product is used for commercial or rental purposes, this warranty will apply for 90 days from the date of purchase.

This warranty gives you specific legal rights, and you may also have other rights which vary from state to state.

Sears, Roebuck and Co., Dept. 817WA, Hoffman Estates, IL 60179

SAFETY RULES

WARNING: For your own safety, read all of the rules and precautions before operating tool.

CAUTION: Always follow proper operating procedures as defined in this manual even if you are familiar with use of this or similar tools. Remember that being careless for even a fraction of a second can result in severe personal injury.

BE PREPARED FOR JOB

- Wear proper apparel. Do not wear loose clothing, gloves, neckties, rings, bracelets or other jewelry which may get caught in moving parts of machine.
- Wear protective hair covering to contain long hair.
- Wear safety shoes with non-slip soles.
- Wear safety glasses complying with United States ANSI Z87.1. Everyday glasses have only impact resistant lenses. They are **NOT** safety glasses.
- Wear face mask or dust mask if operation is dusty.
- Be alert and think clearly. Never operate power tools when tired, intoxicated or when taking medications that cause drowsiness.

PREPARE WORK AREA FOR JOB

- Keep work area clean. Cluttered work areas invite accidents.
- Do not use power tools in dangerous environments.
- Do not use power tools in damp or wet locations. Do not expose power tools to rain.
- Work area should be properly lighted.
- Proper electrical receptacle should be available for tool. Three prong plug should be plugged directly into properly grounded, three-prong receptacle.
- Extension cords should have a grounding prong and the three wires of the extension cord should be of the correct gauge.
- Keep visitors at a safe distance from work area.
- Keep children out of workplace. Make workshop child-proof. Use padlocks, master switches or remove switch keys to prevent any unintentional use of power tools.

TOOL SHOULD BE MAINTAINED

- Always unplug tool prior to inspection.
- Consult manual for specific maintaining and adjusting procedures.
- Keep tool lubricated and clean for safest operation.
- Remove adjusting tools. Form habit of checking to see that adjusting tools are removed before switching machine on.
- Keep all parts in working order. Check to determine that the guard or other parts will operate properly and perform their intended function.
- Check for damaged parts. Check for alignment of moving parts, binding, breakage, mounting and any other condition that may affect a tool's operation.
- A guard or other part that is damaged should be properly repaired or replaced. Do not perform makeshift repairs. (Use parts list provided to order replacement parts.)

KNOW HOW TO USE TOOL

- Use right tool for job. Do not force tool or attachment to do a job for which it was not designed.
- Disconnect tool when changing blades.
- Avoid accidental start-up. Make sure that the switch is in the OFF position before plugging in.
- Do not force tool. It will work most efficiently at the rate for which it was designed.
- Keep hands away from moving parts and cutting surfaces.
- Never leave tool running unattended. Turn the power off and do not leave tool until it comes to a complete stop.
- Do not overreach. Keep proper footing and balance.
- Never stand on tool. Serious injury could occur if tool is tipped or if blade is unintentionally contacted.
- Know your tool. Learn the tool's operation, application and specific limitations.

- Use recommended accessories (refer to page 15). Use of improper accessories may cause risk of injury to persons.
- Handle workpiece correctly. Protect hands from possible injury.
- Turn machine off if it jams. Blade jams when it digs too deeply into workpiece. (Motor force keeps it stuck in the work.)
- Always keep drive, cutterhead and blade guards in place and in proper operating condition.
- Feed work into blade or cutter against direction of rotation.

CAUTION: Think safety! Safety is a combination of operator common sense and alertness at all times when tool is being used.

WARNING: Do not attempt to operate tool until it is completely assembled according to the instructions.

UNPACKING

Refer to Figure 1.

Check for shipping damage. If damage has occurred, a claim must be filed with carrier. Check for completeness. Immediately report missing parts to dealer.

The jointer/planer is shipped complete in one carton. Additional parts which need to be fastened to jointer/planer should be located and accounted for before assembling.

- A Jointer Bed Assembly
- B Fence
- C Fence Bracket Assembly
- D Push Blocks (2)

Hardware bag includes:

- 6-1.0 x 16mm Socket Head Bolts (2)
- 6mm Lock washer (2)
- ¼"-20 x ½" Socket Head Bolts (4)
- ¼"-20 Square Nuts (4)
- 3, 4, 5 L-Wrench
- 8-10 Open Wrench
- Screw Driver

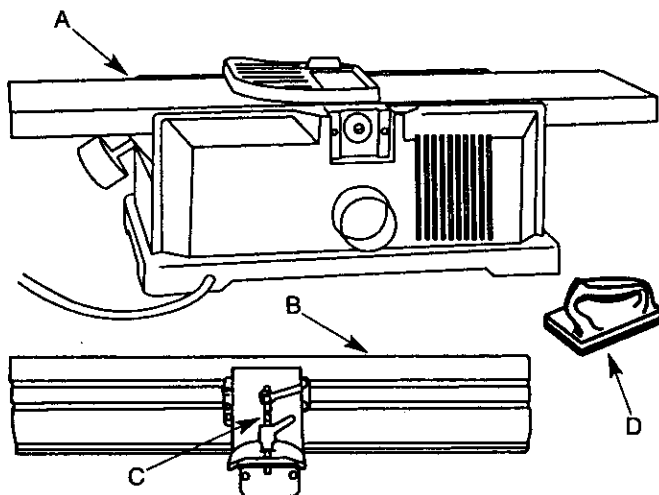

Figure 1 - Unpacking

ASSEMBLY

Refer to Figure 2.

ASSEMBLE FENCE BRACKET TO FENCE

- Lay the fence flat on a level surface so that the surface with the slots is on the top (facing you) and the beveled fence edge coming toward you.
- Make two vertical marks across the fence width using a pencil at $10\frac{3}{16}$ " from each side of the fence.
- Slide two square nuts, one on each slot, from the right side of fence so that the center of the hex nuts are aligned with the pencil mark.
- Slide two square nuts from the left side of the fence up to the pencil mark.

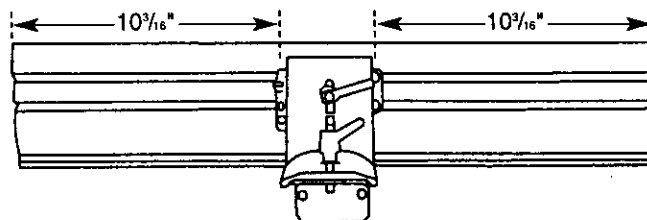

Figure 2 - Assemble Fence Bracket

- Attach the fence bracket to fence using the four ¼" socket head bolts and square nuts. Make sure the fence bracket protrusion with two mounting holes is in the same side as the beveled fence edge.
- Make sure that the two slotted plates on either side of the fence bracket is parallel to the fence bracket.
- Tighten all bolts.

ASSEMBLE FENCE TO JOINTER

- The fence is attached to the rear of the jointer bed assembly using the two mounting holes below the cutterhead.
- Position the fence assembly against the rear of the jointer so that the two mounting holes on the protrusion plate on the fence bracket are aligned with the mounting holes on the rear of the jointer.
- Attach fence assembly to jointer using two 6mm socket head bolts and lock washers provided.
- Loosen the handle on the rear of the fence bracket.
- The fence assembly can be slid forward now.
- Slide fence assembly forward so that the fence is over the jointer tables. At this position the edge of the blade guard will rest against the fence, and the entire width of the cutterhead is covered.
- Place a combination square against face of fence and table surface. The fence and table must be at 90° to each other. If not, loosen the tilt handle and bring face of fence square to table and tighten tilt handle.
- Make sure the pointer on the side of fence bracket reads 0°.
- Tighten all bolts and handles.

INSTALLATION

The jointer/planer weighs approximately 30 lbs. when completely assembled. The jointer/planer must be installed in a place with ample lighting and correct power supply. To install jointer/planer:

- Make sure there is plenty of room for moving the workpiece through the entire cut. There must be enough room that neither the operators nor the bystanders will have to stand in line with the wood while using the tool.
- Jointer/planer can be installed on work using bolts, lock washers and hex nuts (not supplied) or using wood screws (not supplied).
- The $\frac{1}{4}$ " holes (see Figure 3) are intended for installing jointer/planer using bolts, lock washers and hex nuts.
- The $\frac{5}{32}$ " holes (see Figure 3) are intended for installing jointer/planer using wood screws.
- Bolt or clamp the jointer/planer to a firm, level surface.
- Make sure the jointer/planer does not rock and the tables are level.

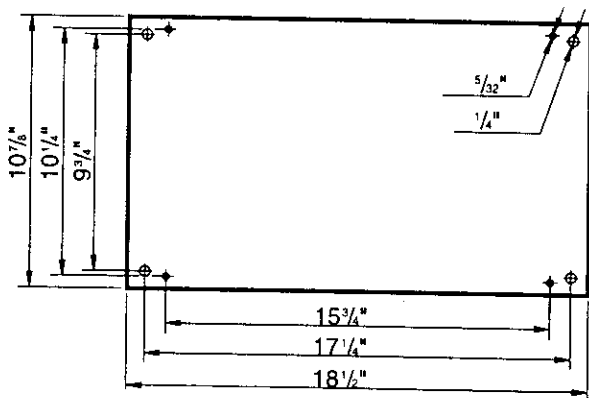

Figure 3 - Installing Jointer/Planer

POWER SOURCE

WARNING: Do not connect jointer/planer to the power source until all assembly steps have been completed.

The motor is designed for operation on the voltage and frequency specified. Normal loads will be handled safely on voltages not more than 10% above or below specified voltage. Running the unit on voltages which are not within range may cause overheating and motor burn-out. Heavy loads require that voltage at motor terminals be no less than the voltage specified on nameplate.

- Power supply to the motor is controlled by a rocker switch. Removing the key from rocker switch will lock the unit and prevent unauthorized use.

GROUNDING INSTRUCTIONS

WARNING: Improper connection of equipment grounding conductor can result in the risk of electrical shock. Equipment should be grounded while in use to protect operator from electrical shock.

- Check with a qualified electrician if you do not understand grounding instructions or if you are in doubt as to whether the tool is properly grounded.

- This tool is equipped with an approved cord rated at 150V and a 3-prong grounding type plug (see Figure 4) for your protection against shock hazards.
- Grounding plug should be plugged directly into a properly installed and grounded 3-prong grounding-type receptacle, as shown (see Figure 4).

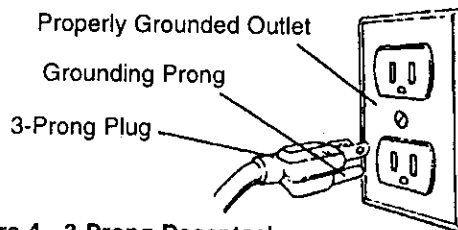

Figure 4 - 3-Prong Receptacle

- Do not remove or alter grounding prong in any manner. In the event of a malfunction or breakdown, grounding provides a path of least resistance for electrical shock.

WARNING: Do not permit fingers to touch the terminals of plug when installing or removing from outlet.

- Plug must be plugged into matching outlet that is properly installed and grounded in accordance with all local codes and ordinances. Do not modify plug provided. If it will not fit in outlet, have proper outlet installed by a qualified electrician.
- Inspect tool cords periodically, and if damaged, have repaired by an authorized service facility.
- Green (or green and yellow) conductor in cord is the grounding wire. If repair or replacement of the electric cord or plug is necessary, do not connect the green (or green and yellow) wire to a live terminal.
- A 2-prong wall receptacle must be replaced with a properly grounded 3-prong receptacle installed in accordance with National Electric Code and local codes and ordinances.

WARNING: Any receptacle replacement should be performed by a qualified electrician.

A temporary 3-prong to 2-prong grounding adapter (see Figure 5) is available for connecting plugs to a two pole outlet if it is properly grounded.

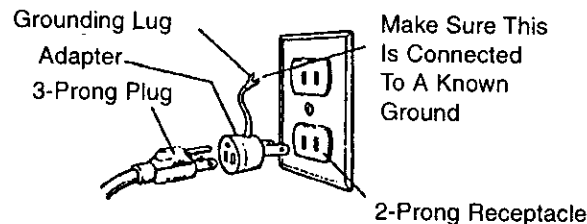

Figure 5 - 2-Prong Receptacle with Adapter

- Do not use a 3-prong to 2-prong grounding adapter unless permitted by local and national codes and ordinances. (A 3-prong to 2-prong grounding adapter is not permitted in Canada.)

Where a 3-prong to 2-prong grounding adapter is permitted, the rigid green tab or terminal on the side of the adapter must be securely connected to a permanent electrical ground such as a properly grounded water pipe, a properly grounded outlet box or a properly grounded wire system.

- Many cover plate screws, water pipes and outlet boxes are not properly grounded. To ensure proper ground, grounding means must be tested by a qualified electrician.

EXTENSION CORDS

- The use of any extension cord will cause some drop in voltage and loss of power.
- Wires of the extension cord must be of sufficient size to carry the current and maintain adequate voltage.
- Use the table to determine the minimum wire size (A.W.G.) extension cord.
- Use only 3-wire extension cords having 3-prong grounding type plugs and 3-pole receptacles which accept the tool plug.
- If the extension cord is worn, cut or damaged in any way, replace it immediately.

EXTENSION CORD LENGTH

Wire Size	A.W.G.
Up to 50 ft.	16
50-100 ft.	14

NOTE: Using extension cords over 100 ft. long is not recommended.

MOTOR

Jointer/planer is supplied with a 1½ HP (max developed) motor.

The 120 Volt AC universal motor has the following specifications:

Horsepower (Maximum Developed)	1½
Voltage	120
Amps	10
Hertz	60
Phase	Single
RPM	8000

ELECTRICAL CONNECTIONS

WARNING: Make sure unit is turned off and disconnected from power source before inspecting any wiring.

The unit is wired as illustrated in the wiring schematic (see Figure 6).

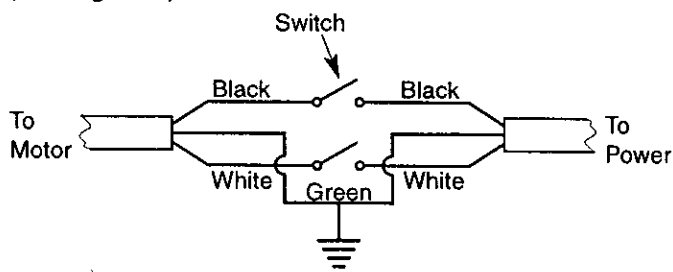

Figure 6 - Wiring Schematic

The motor is assembled with an approved three conductor cord to be used on 120 volts as indicated. The power supply to the motor is controlled by a double pole locking rocker switch.

- Remove the key to prevent unauthorized use. The power lines are inserted directly onto the switch. The green ground line must remain securely fastened to the frame to properly protect against electrical shock.

OPERATION

DESCRIPTION

Craftsman 6½" jointer/planer is used to surface the faces and edges of boards, produce a flat surface on warped boards and shape bevels, chamfers and tapers. The jointer/planer features cast aluminum infeed and outfeed tables, lightweight plastic body with smooth work surfaces and leadscrews for precise table height adjustment. Balanced guide fence tilts 45° (inward) and 45° (outward). Tool comes with locking rocker switch with removable key and push blocks. Jointer/planer easily handles rough-cut lumber, planes hard and soft woods up to 6½" wide using a two blade cutterhead, and takes cuts up to ¼"

OPERATION SAFETY RULES

Jointing is a surfacing operation in which a small amount of wood is removed from the edges and faces of boards to get smooth, straight and even surfaces such that the two edges that run across the planing blocks would fit together perfectly, forming a seamless joint.

Planing refers to the sizing of lumber to a desired thickness while creating a level surface parallel to the opposite side of the board. Depth of cut is the term used to indicate how deep the blades will cut into the workpiece.

WARNING: Operation of any power tool can result in foreign objects being thrown into eyes which can result in severe eye damage. Always wear safety goggles complying with United States ANSI Z87.1 (shown on package) before commencing power tool operation.

WARNING: For your own safety, read all of the instructions and safety precautions before operating tool.

- Know general power tool safety. Make sure all precautions are understood (see pages 2, 3, 5 and 6).
- Whenever adjusting or replacing any parts on jointer/planer, turn switch off and remove plug from power source.
- Make sure all guards are properly attached and securely fastened.
- Make sure all moving parts are free from interference.
- Always wear eye protection or face shield.
- Make sure blades are aligned and properly attached to cutterhead.
- Do not plug in jointer/planer unless switch is in "off" position. After turning switch on, allow jointer/planer to come to full speed before operating.
- Keep hands clear of all moving parts.
- Do not force cut. Slowing or stalling will overheat motor.

- Use quality lumber. Blades last longer and cuts are smoother with good quality wood.
- Do not perform jointing/planing operations on material shorter than 8 1/2", narrower than 3/4", or less than 1/4" thick
- Never make jointing cut deeper than 1/8".
- Always keep cutterhead and blade guards in proper working condition.
- Maintain the proper relationships of infeed and outfeed table surfaces and cutterhead blade path.
- Do not back the work toward the infeed table.
- Support the workpiece adequately at all times during operation; maintain control of the workpiece.
- Use hold-down/push blocks for jointing material narrower than 3" or planing material thinner than 3".
- Take precautions against kickback. Do not permit anyone to stand or cross in line of cutterhead's rotation. Kickback or thrown debris will travel in this direction.
- Turn switch off and disconnect power whenever jointer/planer is not in use.
- Replace or sharpen blades as they become damaged or dull.
- Do not attempt to perform an abnormal or little used operation without study and the use of adequate hold-down/push blocks, jigs, fixtures, stops and the like.
- Keep jointer/planer maintained. Follow maintenance instructions (see pages 9-10).

DEPTH OF CUT

Refer to Figure 7.

The depth of cut is adjusted by the relative positioning of the infeed table with respect to the cutterhead. Infeed table can be raised or lowered using the handwheel.

Turning the handwheel counterclockwise will lower the infeed table causing more wood to be removed from workpiece. Turning the handwheel clockwise will raise the infeed table causing less wood to be removed from workpiece.

Do not make jointing or planing cuts deeper than 1/8".

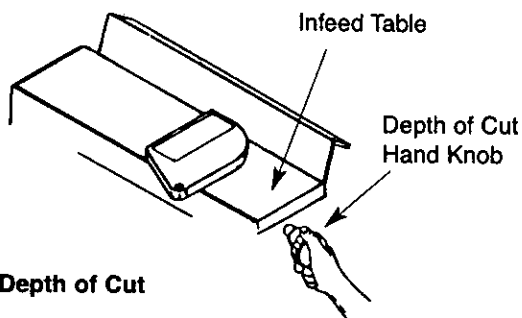

Figure 7 - Depth of Cut

CHECK DEPTH OF CUT

Refer to Figure 8.

- Place a straight edge on the outfeed table extending over the infeed table.
- Measure from the surface of the infeed table to the bottom of the straight edge. This will be the depth of cut.

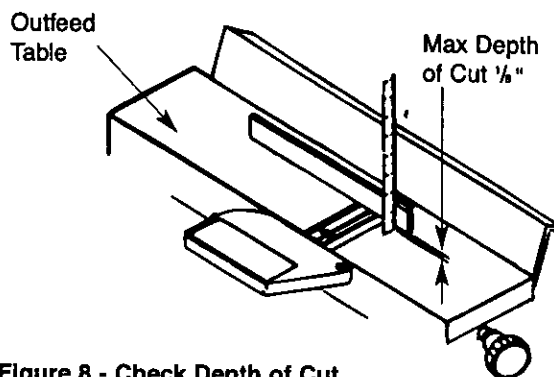

Figure 8 - Check Depth of Cut

NOTE: This jointer/planer will make a maximum 1/8" deep cut. To reduce the danger of kickback and possible injury, the depth of cut should not exceed 1/16".

CAUTION: Make sure the switch is in the "off" position and the cord is unplugged from power source before performing this check.

POSITIONING FENCE

The fence can be adjusted to cut various angles from 0°-45° inward and outward. The fence can be tilted inward up to 45° (toward the cutterhead) to maintain greater stability of a narrow workpiece or up to 45° outward (away from cutterhead) for larger angle cutting operations.

To adjust tilt angle:

- Loosen fence tilt handle.
- The fence tilt handle is spring loaded. To continue turning the handle, gently pull the handle away from the fence and return it to the original position.
- Release the handle and continue loosening.
- Manually tilt fence inward/outward to the desired angle. Use the scale on the left side of fence bracket to measure tilt angle.

NOTE: The fence has positive stops at 0° (90° from table) and at 45° inward.

- Tighten fence tilt handle.
- To continue tightening, gently pull the handle away from fence and return the handle to the original position.
- Release the handle and continue tightening.
- Make sure the fence is tight and secure.

The slotted plates on the fence bracket prevent the blades from being exposed. Do not remove the plates at any time. The fence can be positioned so that the desired width of the blade is exposed.

To adjust fence position:

- Loosen fence slide handle.
- Slide fence forward to the desired position.
- Tighten fence slide handle.
- Make sure fence is tight and secure.
- Loosen fence lock handle.

CAUTION: Do not remove blade guard and slotted plates. Make sure that the cutterhead is covered all the time.

CAUTION: Do not slide fence away from the jointer body. All sides of the cutterhead must be covered all the time.

BLADE GUARD

The blade guard provides protection over the cutterhead. It must always be in place and function properly. Check the guard to make sure it functions properly. To check:

- Pass a 1/4" thick piece of wood over the cutterhead between the guard and the fence. The guard will spread and leave way for the wood piece to pass. The guard must return to the original position automatically when the wood piece is removed.
- Open the blade guard all the way until it stops, and release it several times. It should always return to its original position by spring action.

CAUTION: If the blade guard fails to operate properly, the spring must be replaced or adjusted.

- To replace spring, contact your nearest Sears store or service center.
- To adjust or to assemble spring see "Adjusting Blade Guard", page 9.

ADJUSTING BLADE HEIGHT

Refer to Figures 9 and 10.

CAUTION: Make sure the switch is in the "OFF" position and cord is unplugged before proceeding with checking blades.

The blades have been adjusted at the factory to assure proper operation and should require no adjustment. However, shipping and handling may have caused misalignment. For accurate cutting, the blades must be 0.003" higher than the outfeed table when positioned at the highest point. To check blade height:

- Block the blade guard from closing using a scrap piece of wood about 6 1/4" long between the fence and blade guard.

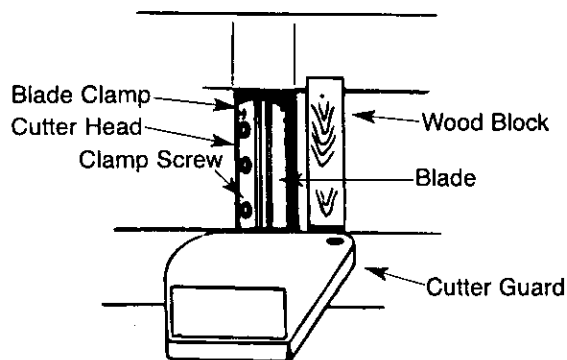

Figure 9 - Block Blade Guard

- Turn the cutterhead so that one of the blades is at the highest position.

CAUTION: The cutterhead blades are extremely sharp. Do not let your fingers contact the cutting edge at any time.

- Place a straightedge over the outfeed table and the blade.

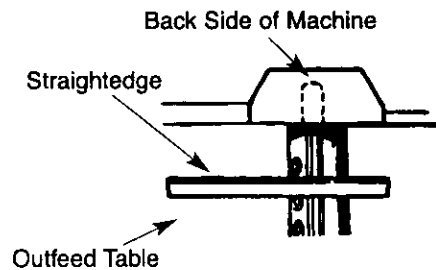

Figure 10 - Adjust Blade Height

- The straight edge must touch evenly on the outfeed table at both ends of the blade.
- Turn the cutterhead slowly, and check if the blade lightly touches the straight edge.
- If the straightedge raises, loosen the blade lock screws and gently tap the blade with a piece of scrap wood. If the blade does not touch the straight-edge, loosen the blade lock screws and raise the blade by prying the lower edge of the blade against the outfeed table using a screwdriver.
- Tighten blade lock screws.

AVOID DAMAGE TO BLADES

Jointer/planer is a precision woodworking machine and should only be used on quality lumber. Using bad lumber could result in a poor quality cut on subsequent pieces.

For proper operation, it is preferable to use the jointer with a dust collecting system (see "Using a Vacuum Hose", page 9) attached to the exhaust port in the rear of the jointer. Attaching a dust collecting system is especially required when taking deeper cuts to prevent clogging of wood chips.

- Do not use dirty boards. Dirt and stones are abrasive and will wear blade.
- Remove nails and staples. Jointer should only cut wood.
- Avoid knots. Heavy cross-grain makes knots hard and they can come loose and jam the jointer.
- Assess value of badly warped boards. Operator can be tempted to use too deep of cut to square boards quickly. Use several passes to maintain a level surface.

ON-OFF SWITCH

Refer to Figure 11, page 8.

The operating positions of the "On-Off" switch are located on the front of your jointer/planer.

- Push the switch up to turn jointer/planer on and push down to turn the unit off.
- The switch has a removable key that allows the unit to be locked in the "Off" position.

To activate locking mechanism:

- Push the switch to "Off" position.
- Pull switch key.

To deactivate locking mechanism:

- Insert and press switch key in the slot on switch.

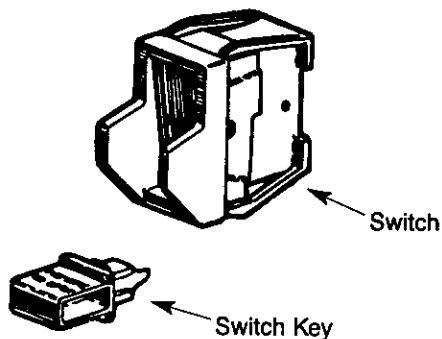

Figure 11 - On-Off Switch

WARNING: Be sure the switch is in "OFF" position and the cord is unplugged from the power source before removing switch key.

FEEDING WORKPIECE

Refer to Figures 12, 13, 14 and 15.

Feed rate refers to rate at which wood is passed over blades. An even feed will produce a uniform surface. To feed workpiece:

- Hold the board firmly down on both tables and against the fence.
- Keep fingers close together.
- Feed the board at a continuous even rate of speed. Any hesitation or stopping could cause a "step" to be cut on the edge of the board.

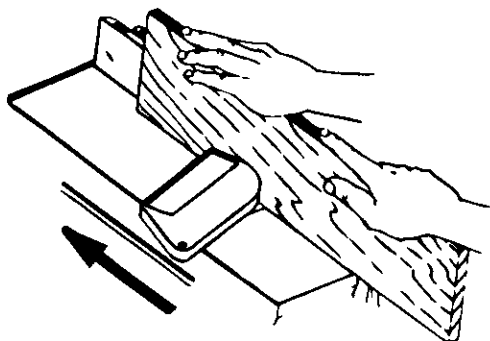

Figure 12 - Feeding Workpiece

- As the trailing hand passes over the cutterhead, remove the leading hand.
- Continue feeding while placing the leading hand behind the trailing hand until the entire length of the board is cut.

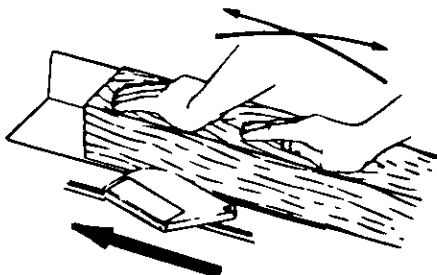

Figure 13 - Guiding Workpiece

- Feed with the grain whenever possible.

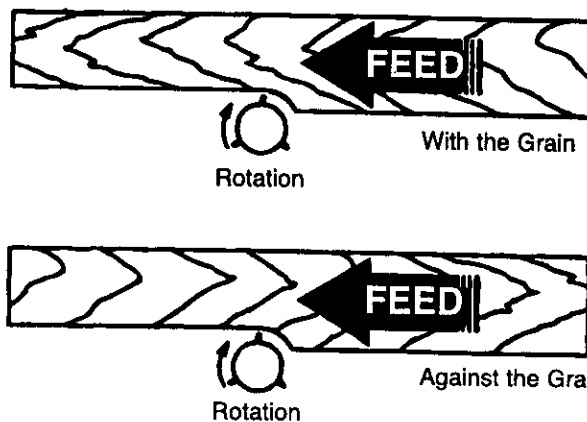

Figure 14 - Direction of Feed

- If the nature of the workpiece is such that it must be fed against the grain, take very light cuts and feed slowly.
- When using long workpieces, to avoid injury from slips or kickbacks and to exert even pressure on the cutterhead, use extra supports (see Recommended Accessories, page 15) at both infeed and outfeed ends.

USING HOLD DOWN/PUSH BLOCKS

Refer to Figure 15.

- Always use hold-down/push-blocks when jointing, or rabbeting wood that is narrower than 3", planing wood thinner than 3".

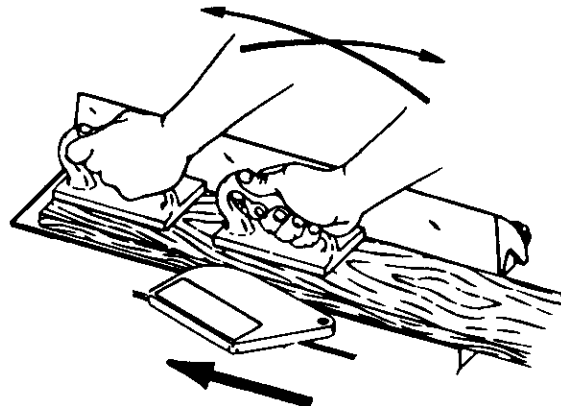

Figure 15 - Feeding with Push Blocks

- Grasp the hold-down/push-blocks firmly.
- Position the push-blocks flat on top of workpiece and push the workpiece down against the table.
- Use a hand-over-hand motion to maintain control over the workpiece at all times.
- When planing workpiece between 1/2" - 3/4" and narrower than the push-blocks, tilt the push-blocks so that it clears the cutterhead guard while feeding.

BEVELING AND CHAMFERING

Refer to Figure 16, page 9.

- The fence on the jointer/planer is adjustable from 45° inward to 45° outward. Adjust the fence to the desired angle and tighten fence lock knobs. You may require to lift the positive pin to move fence.

- Beveling refers to cutting the entire edge of a board at an angle. Beveling may require several passes due to the depth of cut needed.
- Chamfering refers to removing only the corner of the edge of a board. Normally a chamfer is made on one pass; so a $\frac{1}{16}$ " depth of cut is made.

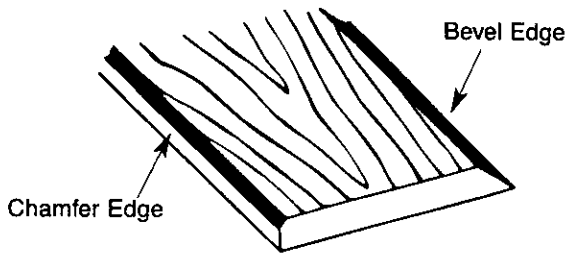

Figure 16 - Beveling and Chamfering

USING A VACUUM HOSE

A standard dust collection hose can be attached to the exhaust port (2 $\frac{1}{2}$ " Dia.) on the rear of the jointer. Jointer will perform properly at all depths of cuts up to $\frac{1}{8}$ " when used with a dust collecting system. (See "Avoid Damage to Blades", page 7.) To attach a dust collecting system:

- Insert the dust collection hose to the exhaust port on the rear of the jointer.
- Turn the dust collecting system on.
- Turn the jointer on.
- Periodically replace/empty bag in dust collecting system.

MAINTENANCE

WARNING: Turn the switch to "Off" position and unplug jointer/planer from power source before proceeding to do maintenance work.

CHECKING FOR WORN BLADES

Condition of blades will affect precision of cut. If blade wear is not observed when checking the blade height, the quality of cut will indicate the blade condition. Dull blades will tear rather than sever wood fiber. A raised grain will occur when dull blades pound on wood where there is difference in density. A raised ridge will be produced where the blades have been nicked.

SHARPENING BLADES

Refer to Figure 17.

The blades can be honed individually by whetting them with a fine sharpening stone. Make sure oilstone is flat and is not worn. To sharpen blades:

- Partially cover the stone with paper to protect the table top.
- Position infeed table so stone will contact blade along its beveled surface.
- Stroke the stone across blade from one side to other while stone is also moved slightly in the direction of feed.
- Make sure to do the same number of strokes on each place.

If the blades are nicked they must be replaced or reground. They can be reground several times until they become $\frac{13}{16}$ " wide.

NOTE: Many shops do not have capabilities to resurface blades. Yellow pages should list "Sharpening Services" or "Tool Grinding."

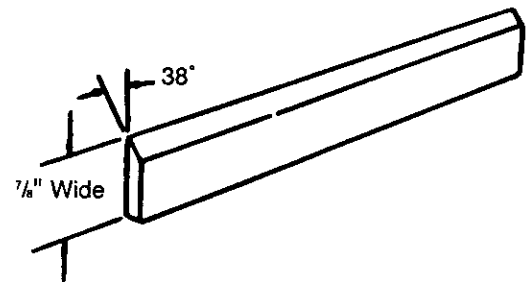

Figure 17 - Sharpening Blades

Never install unbalanced blades or reground blades less than $\frac{13}{16}$ " wide.

REPLACING BLADES

Refer to Figures 18 and 19, pages 9 and 10.

- Unplug the jointer/planer from power source and turn the switch to "OFF" position.
- Block the blade guard from closing down.
- Loosen and remove three blade lock screws securing blade and blade clamp.

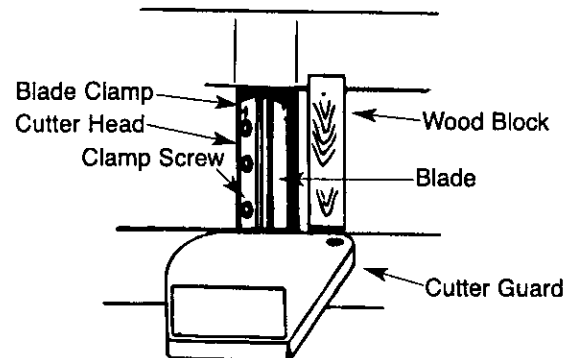

Figure 18 - Block Blade Guard

- Lift blade and blade clamp from cutterhead
- Clean any sawdust and resin buildup from cutterhead and blade clamp.
- Place blade clamp against the replacement blade and replace in cutterhead.
- Secure blade and blade clamp using three blade lock screws. Do not tighten blade lock screws.

NOTE: Check blade height at both ends of blade (see Adjusting Blade Height, page 7).

- Tighten blade lock screws.
- Recheck blade adjustment and make sure blade is still level with outfeed table.
- Repeat the procedure to replace the other blade.
- Remove the scrap wood and release blade guard.
- Make sure all the blade lock screws are tight and snug.

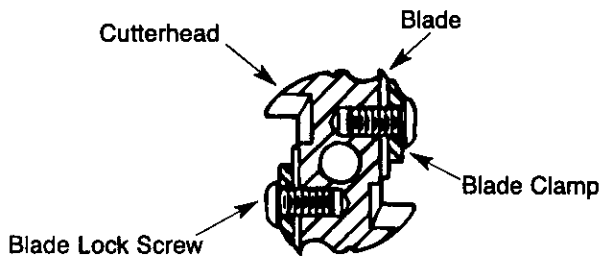

Figure 19 - Replacing Blades

ADJUSTING BLADE GUARD

CAUTION: Do not lubricate the pivot point of the blade guard. Oil and lubricating products may contain chemicals that can damage and/or destroy blade guard or other plastic parts.

The blade guard needs adjustment or spring replacement if it does not cover the cutterhead when released. To adjust or replace spring:

- Lay the jointer/planer on the side so that the switch is facing the roof.
- Loosen and remove screw and wavy washer on the base that secure the blade guard.
- Slide out blade guard.
- If the spring is out of tension, it must be replaced. Slide out spring from the dimple. Contact your nearest Sears store or service center for replacement.
- Replace new spring so that the short arm of the spring is inside the hole on the body.
- Position blade guard so that the long arm of the spring is against the wall of the blade guard.
- Secure blade guard using pan head screw and washer.
- Make sure blade guard functions appropriately.

REPLACING TIMING BELT

Refer to Figures 20 and 21.

- Turn the switch to "OFF" position and unplug the tool from power source.
- Lay the jointer/planer on the side so that the switch faces the roof.
- Remove old timing belt by turning belt and maintaining pressure.

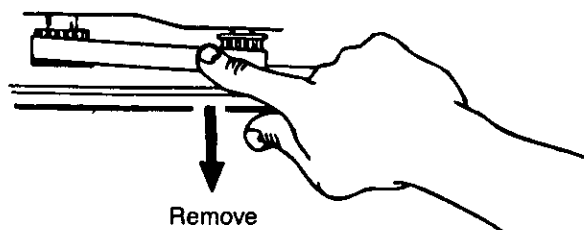

Figure 20 - Removing Timing Belt

- Replace with new timing belt by maintaining inward pressure.

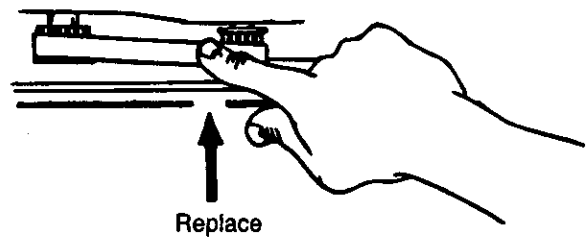

Figure 21 - Replacing Timing Belt

NOTE: Make sure that the full width of belt is on both pulleys.

GENERAL MAINTENANCE

Jointer/planer will operate best if it is kept in good operating condition. Keep unit adjusted as described in "Operation."

- Do not allow gum and pitch to accumulate on the tables, fence, blades and blade guard.
- Apply a thin coat of paste type wax to the tables and the fence so that the wood slides easily while feeding.
- Do not allow chips to accumulate on the underside of the jointer/planer.
- Keep blades sharp (see "Sharpening Blades," page 9). Sometimes replacing blades is less expensive than resurfacing them. Keeping a spare set of blades on hand is recommended. Blades should always be sharpened or replaced in sets of two.

LUBRICATION

WARNING: Make sure the switch is in the "OFF" position and the tool is disconnected from the power source.

WARNING: Do not at any time let brake fluids, gasoline, penetrating oils, etc. come in contact with plastic parts. They contain chemicals that can damage and/or destroy plastics.

- Motor and cutterhead bearings are sealed and need no lubrication.
- Fence, trunnion, trunnion cover and elevation screws should be cleaned of debris and greased as needed.

MACHINED SURFACES

- Surface of tables and fence must be kept smooth and clean for easy work feed.
- Apply a paste wax to surfaces to keep them slick and prevent corrosion.

TROUBLESHOOTING

SYMPTOM	POSSIBLE CAUSE(S)	CORRECTIVE ACTION
Motor does not start	<ol style="list-style-type: none"> 1. Defective switch 2. Defective motor 3. Low line voltage 	<ol style="list-style-type: none"> 1. Have switch replaced. 2. Have motor replaced/repared. <p>NOTE: 1 and 2 must be done by a qualified service technician; Consult Sears service.</p> <ol style="list-style-type: none"> 3. Correct low line voltage condition.
Motor stalls (resulting in blown fuses or tripped circuit breakers)	<ol style="list-style-type: none"> 1. Circuit overloaded 2. Low line voltage 3. Motor overloaded 4. Incorrect fuses on circuit breakers 5. Short circuit in motor; loose connections or worn insulation on lead wires 	<ol style="list-style-type: none"> 1. Reduce circuit load (turn off other appliances). 2. Correct low line voltage conditions. 3. Reduce load on motor. 4. Have correct fuses on circuit breakers installed. 5. Inspect terminals in motor for damaged insulation and shorted wires and have them replaced.
Motor starts slowly or fails to come to full speed	<ol style="list-style-type: none"> 1. Defective motor windings 2. Clogged wood chips 	<ol style="list-style-type: none"> 1. Have motor replaced/repared. 2. Take shallow depth of cut and attach a shop-vac to exhaust port.
Motor running too hot	<ol style="list-style-type: none"> 1. Motor overloaded 2. Restricted air circulation due to dust accumulation 	<ol style="list-style-type: none"> 1. Reduce load on motor. 2. Clean dust and restore normal air circulation.
Frequent opening of fuses or circuit breakers	<ol style="list-style-type: none"> 1. Motor overloaded 2. Fuses or circuit breakers do not have sufficient capacity 3. Circuit overloaded 	<ol style="list-style-type: none"> 1. Reduce load on motor 2. Have correct fuses or circuit breakers installed. 3. Reduce circuit load (turn off other appliances).
Snipe (gouging at end of boards)	<ol style="list-style-type: none"> 1. Dull blades 2. Inadequate support of long boards 3. Uneven feed 	<ol style="list-style-type: none"> 1. Replace or sharpen blades. See "Sharpening Blades," page 9. 2. Support long boards. See "Recommended Accessories," page 15. 3. See "Feeding Workpiece," page 8.
Uneven depth of cut	<ol style="list-style-type: none"> 1. Blade height not uniform 2. Fence not perpendicular to jointer bed 3. Feeding wood too fast 	<ol style="list-style-type: none"> 1. Adjust blade height. See "Adjusting Blade Height," page 7. 2. See "Positioning Fence," page 6. 3. Feed wood slower.
45° cuts inaccurate	<ol style="list-style-type: none"> 1. Fence stops not adjusted properly 2. Fence bottom not even with outfeed table due to wood chips under fence 	<ol style="list-style-type: none"> 1. Adjust fence stops. See "Positioning Fence.", page 6. 2. Clean wood chips from underside of fence.
Fuzzy grain	Planing wood with high moisture	Remove high moisture content from wood by drying.
Torn grain	<ol style="list-style-type: none"> 1. Too heavy a cut 2. Blades cutting against grain 3. Dull blades 	<ol style="list-style-type: none"> 1. Reduce depth of cut. 2. Feed work along grain. 3. Replace or sharpen blades.

NOTES

Model 351.217280

Figure 22 - Replacement Parts Illustration for Motor

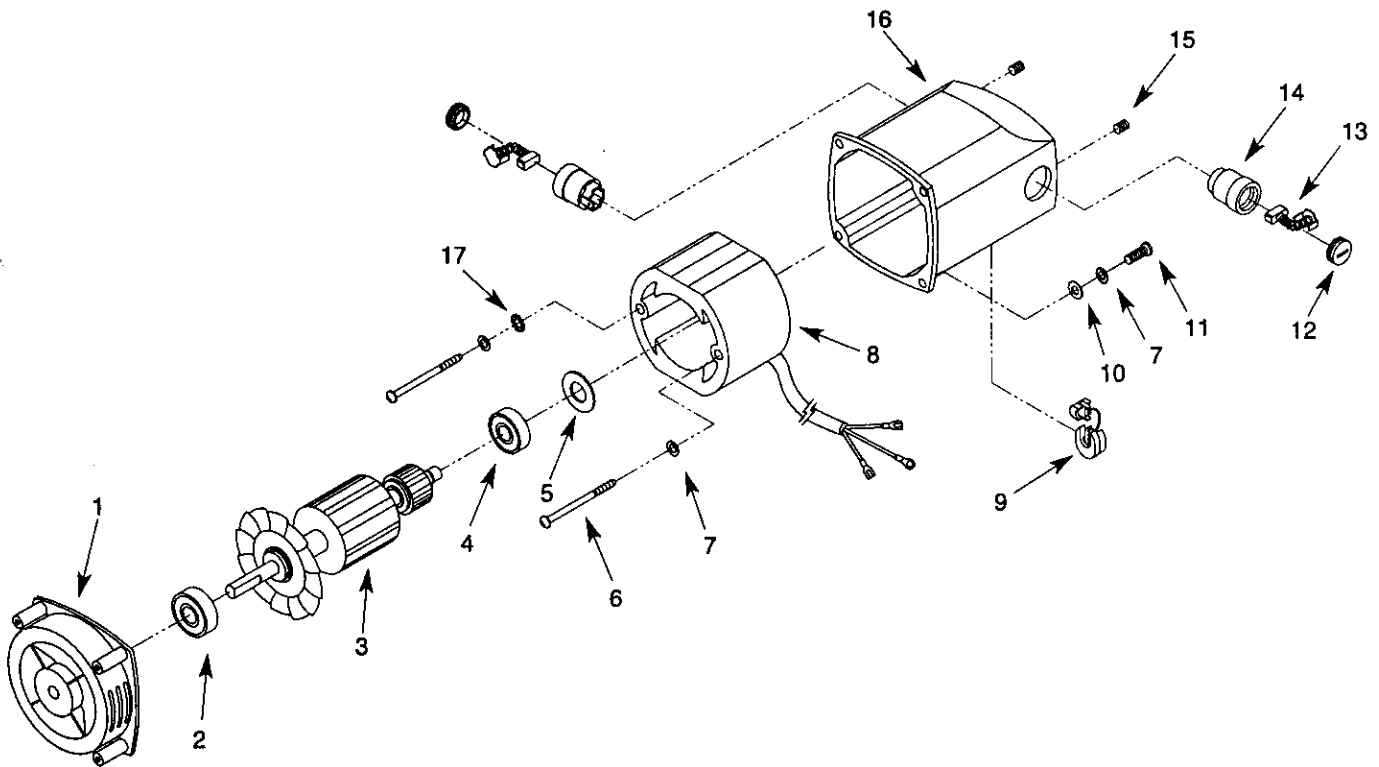

REPLACEMENT PARTS LIST FOR MOTOR

KEY NO.	PART NO.	DESCRIPTION	QTY.
1	2856.00	Motor Cover	1
2	STD315215	6201ZZ Ball Bearing	1
3	2857.00	Armature with Fan	1
4	STD315205	6200ZZ Ball Bearing*	1
5	2858.00	Wavy Washer	1
6	2859.00	Thread Forming Screw	2
7	STD852005	5mm Lock Washer*	6
8	2860.00	Stator	1
9	1413.00	Strain Relief	1
10	STD851005	5mm Flat Washer*	4
11	5383.00	5-0.8 x 16mm Hex Head Bolt	4
12	2861.00	Brush Cap	2
13	2862.00	Carbon Brush (set of 2)	1
14	2863.00	Brush Holder	2
15	1838.00	5-0.8 x 10mm Set Screw	2
16	2864.00	Motor Housing	1
17	1474.00	5mm Serrated Washer	1

* Standard hardware item available locally

PARTS LIST

Model 351.217680

Figure 23 - Replacement Parts Illustration for Jointer

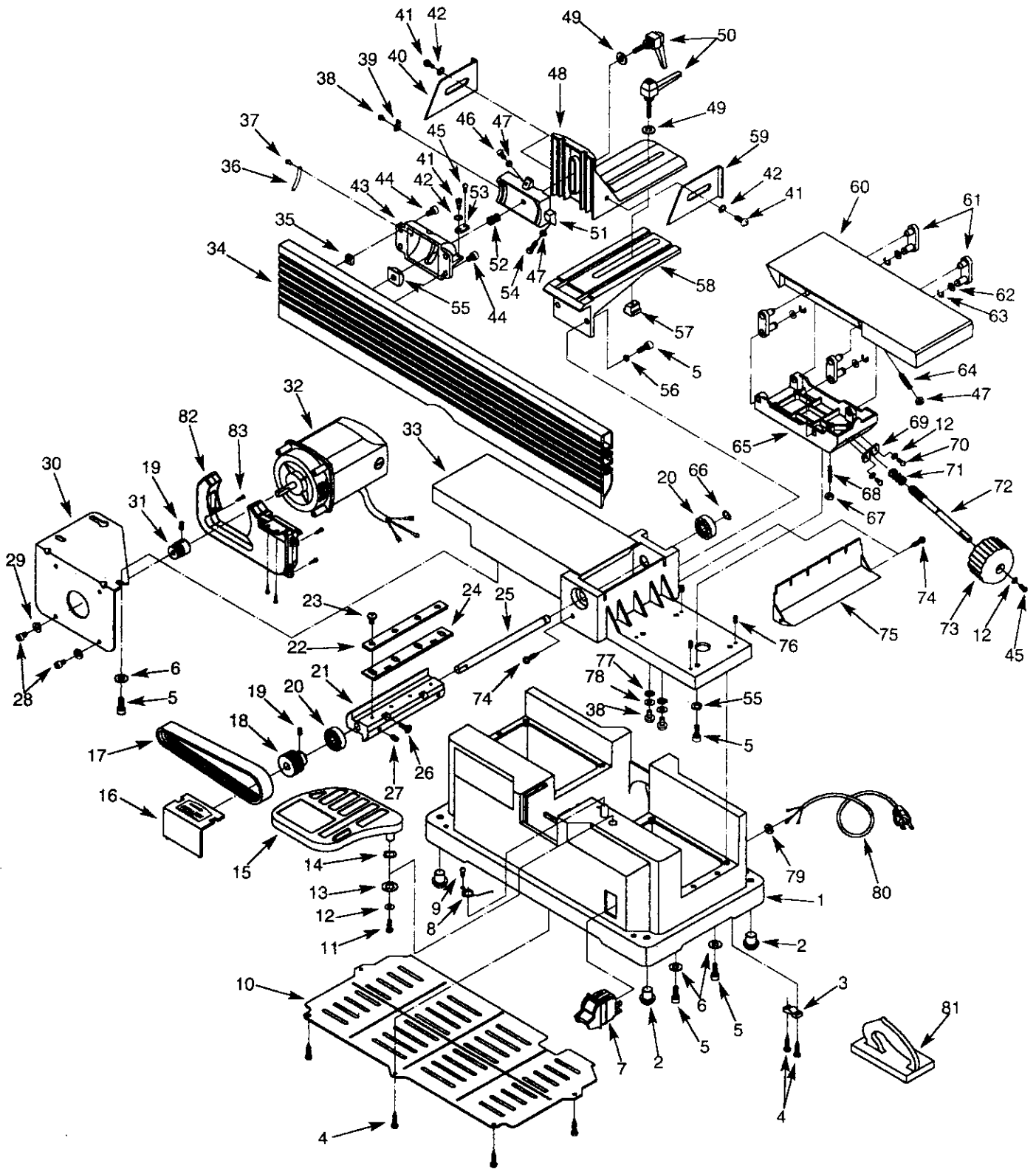

REPLACEMENT PARTS LIST FOR JOINTER

KEY NO.	PART NO.	DESCRIPTION	QTY.
1	2893.01	Base	1
2	4135.00	Foot Pad	4
3	1553.00	Cord Clamp	1
4	2895.00	Thread Forming Screw	8
5	0850.00	6-1.0 x 16mm Socket Head Bolt	18
6	9722.00	7mm Special Washer	10
7	0423.00	Switch	1
8	2892.00	Spring	1
9	9729.00	Thread Forming Screw	1
10	2894.00	Cover	1
11	0361.00	5-0.8 x 8mm Pan Head Screw	1
12	STD851005	5mm Flat Washer*	4
13	9723.00	7mm Special Washer	1
14	3499.00	Wavy Washer	1
15	2891.00	Blade Guard	1
16	4128.00	Access Cover	1
17	2887.00	Belt	1
18	2886.00	Drive Pulley	1
19	0964.00	6-1.0 x 6mm Set Screw	2
20	STD315205	6200ZZ Ball Bearing*	2
21	2885.00	Cutterhead	1
22	2883.00	Blade Clamp	2
23	6346.00	6-1.0 x 12mm Socket Pan Head Screw	8
24	922994.00	Blade (set of 2)	1
25	2881.00	Shaft	1
26	3835.00	5-0.8 x 12mm Flat Head Screw	4
27	2803.00	6-1.0 x 12mm Set Screw	2
28	3855.00	5-0.8 x 10mm Socket Head Bolt	4
29	STD851005	5mm Lock Washer*	4
30	2888.01	Motor Mounting Plate	1
31	2889.00	Motor Pulley	1
32	2890.00	Motor	1
33	2880.02	Outfeed Table	1
34	2865.00	Fence	1
35	2866.00	1/4-20" Square Nut	4
36	2898.00	Scale	1
37	1286.00	Rivet	2
38	0781.00	4-0.7 x 8mm Pan Head Screw	3
39	2896.00	Indicator	1
40	2897.00	Right Side Slotted Plate	1
41	2872.00	Shoulder Bolt	3

KEY NO.	PART NO.	DESCRIPTION	QTY.
42	9725.00	Wavy Washer	3
43	2868.00	Trunnion Holder	1
44	1993.00	1/4-20 x 1/2" Socket Head Bolt	4
45	1903.00	4-0.7 x 10mm Pan Head Screw	2
46	9720.00	5-0.8 x 10mm Hex Head Bolt	1
47	STD840508	5-0.8mm Hex Nut*	3
48	2873.00	Fence Bracket	1
49	9724.00	6mm Special Washer	2
50	2874.00	Handle	2
51	2870.00	Trunnion	1
52	9727.00	Spring	1
53	2871.00	Plate	1
54	5383.00	5-0.8 x 16mm Hex Head Bolt	1
55	2867.00	Support Nut	1
56	STD852006	6mm Lock Washer*	6
57	2876.00	T-Nut	1
58	2875.00	Fence Support	1
59	9726.00	Left Side Slotted Plate	1
60	2878.01	Infeed Table	1
61	3267.00	Bracket	4
62	9728.00	8mm Special Washer	4
63	6461.00	3CMI-8 Retaining Ring	4
64	5223.00	5-0.8 x 30mm Set Screw	1
65	2877.00	Table Frame	1
66	0221.00	3AMI-10 Retaining Ring	1
67	STD840610	6-1.0mm Hex Nut*	1
68	9721.00	6-1.0 x 30mm Set Screw	1
69	2879.00	Support Plate	1
70	0781.00	4-0.7 x 8mm Pan Head Screw	2
71	3270.00	Spring	1
72	3271.00	Elevation Screw	1
73	3272.00	Knob	1
74	2101.00	Thread Forming Screw	2
75	2899.01	Chip Chute	1
76	0351.00	6-1.0 x 10mm Set Screw	4
77	5156.00	4mm Serrated Washer	2
78	STD851004	4mm Flat Washer*	2
79	4137.00	Grommet	1
80	1412.01	Line Cord	1
81	9-73666	Push Block (set)	1
82	16404.00	Baffle	1
83	16405.00	Thread Forming Screw	5
Δ	16303.00	Owner's Manual	1

* Standard hardware item available locally

Δ Not Shown

Recommended Accessories

Δ	Horizontal Roller Stand	351.21417
Δ	Push Block (set)	9-22994

**In U.S.A. or Canada
for in-home major brand repair service:**

Call 24 hours a day, 7 days a week

1-800-4-MY-HOMESM (1-800-469-4663)

Para pedir servicio de reparación a domicilio – 1-800-676-5811

Au Canada pour tout le service – 1-877-LE-FOYERSM (1-877-533-6937)

For the repair or replacement parts you need:

Call 6 a.m. – 11 p.m. CST, 7 days a week

PartsDirectSM

1-800-366-PART (1-800-366-7278)

www.sears.com/partsdirect

Para ordenar piezas con entrega a domicilio – 1-800-659-7084

For the location of a Sears Service Center in your area:

Call 24 hours a day, 7 days a week

1-800-488-1222

To purchase or inquire about a Sears Maintenance Agreement:

Call 7 a.m. – 5 p.m. CST, Monday – Saturday

1-800-827-6655

