

Owner's Manual

CRAFTSMAN®

PROFESSIONAL

3/8 in. PROFESSIONAL CORDLESS DRILL-DRIVER Variable Speed / Reversible

Model No.
973.271600

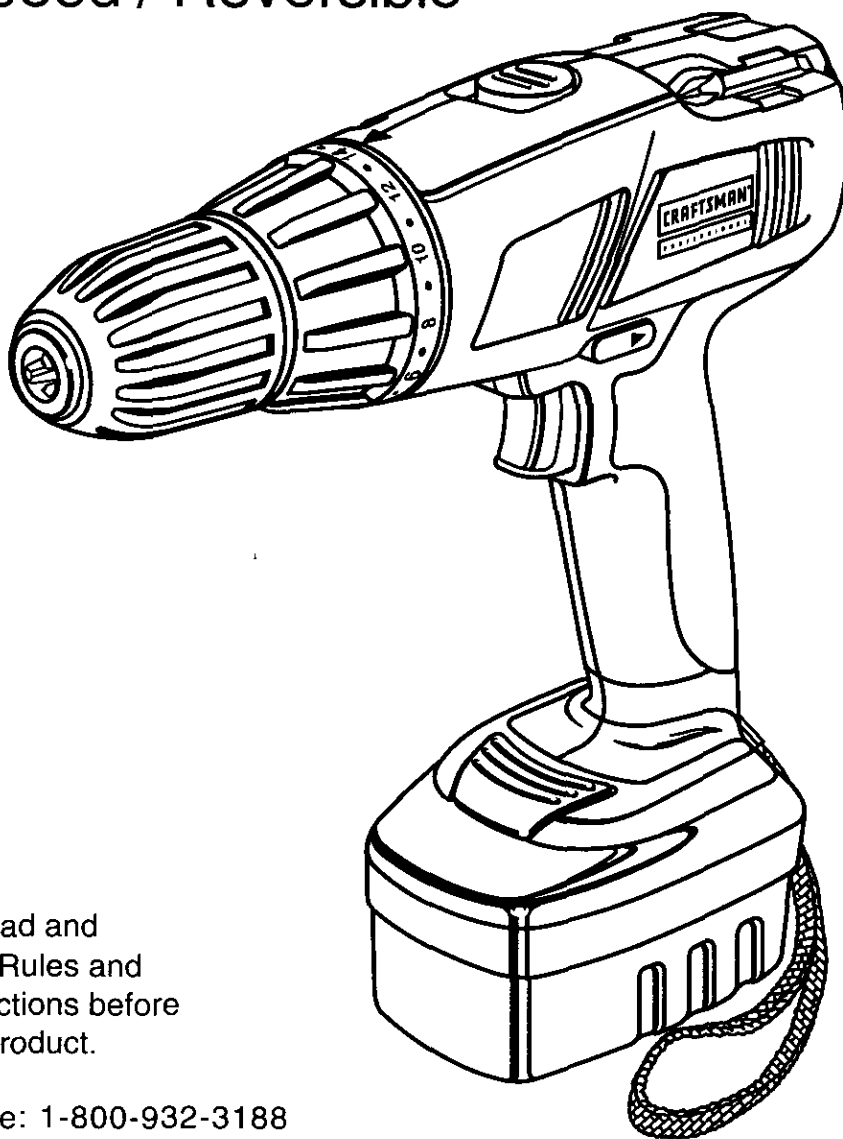

Save this manual for
future reference

⚠ CAUTION: Read and
follow all Safety Rules and
Operating Instructions before
first use of this product.

Customer Help Line: 1-800-932-3188

Sears, Roebuck and Co., Hoffman Estates, IL 60179 USA
Visit the Craftsman web page: www.sears.com/craftsman

972000-754
4-00

- Safety
- Features
- Assembly
- Operation
- Maintenance
- Parts List



TABLE OF CONTENTS

■ General Safety Rules	2-3
■ Specific Safety Rules/Symbols	3-5
■ Features	5-7
■ Assembly	8-9
■ Operation	10-14
■ Maintenance	15
■ Accessories	16
■ Exploded View And Repair Parts List	17
■ Parts Ordering / Service	18

GENERAL SAFETY RULES

- ⚠ WARNING: Read and understand all instructions.** Failure to follow all instructions listed below, may result in electric shock, fire and/or serious personal injury.

SAVE THESE INSTRUCTIONS

Work Area

- **Keep your work area clean and well lit.** Cluttered benches and dark areas invite accidents.
- **Do not operate power tools in explosive atmospheres, such as in the presence of flammable liquids, gases, or dust.** Power tools create sparks which may ignite the dust or fumes.
- **Keep bystanders, children, and visitors away while operating a power tool.** Distractions can cause you to lose control.

Electrical Safety

- **Do not abuse the cord. Never use the cord to carry the charger. Keep cord away from heat, oil, sharp edges, or moving parts. Replace damaged cords immediately.** Damaged cords may create a fire.
- **A battery operated tool with integral batteries or a separate battery pack must be recharged only with the specified charger for the battery.** A charger that may be suitable for one type of battery may create a risk of fire when used with another battery.
- **Use battery operated tool only with specifically designated battery pack.** Use of any other batteries may create a risk of fire. Use only with battery pack listed.

Personal Safety

- **Stay alert, watch what you are doing and use common sense when operating a power tool. Do not use tool while tired or under the influence of drugs, alcohol, or medication.** A moment of inattention while operating power tools may result in serious personal injury.
- **Dress properly. Do not wear loose clothing or jewelry. Contain long hair. Keep your hair, clothing, and gloves away from moving parts.** Loose clothes, jewelry, or long hair can be caught in moving parts.
- **Avoid accidental starting. Be sure switch is in the locked or off position before inserting battery pack.** Carrying tools with your finger on the switch or inserting the battery pack into a tool with the switch on, invites accidents.
- **Remove adjusting keys or wrenches before turning the tool on.** A wrench or a key that is left attached to a rotating part of the tool may result in personal injury.
- **Do not overreach. Keep proper footing and balance at all times.** Proper footing and balance enable better control of the tool in unexpected situations.
- **Use safety equipment. Always wear eye protection.** Dust mask, non-skid safety shoes, hard hat, or hearing protection must be used for appropriate conditions.

GENERAL SAFETY RULES

Tool Use and Care

- **Use clamps or other practical way to secure and support the workpiece to a stable platform.** Holding the work by hand or against your body is unstable and may lead to loss of control.
- **Do not force tool. Use the correct tool for your application.** The correct tool will do the job better and safer at the rate for which it is designed.
- **Do not use tool if switch does not turn it on or off.** A tool that cannot be controlled with the switch is dangerous and must be repaired.
- **Disconnect battery pack from tool or place the switch in the locked or off position before making any adjustments, changing accessories, or storing the tool.** Such preventive safety measures reduce risk of starting the tool accidentally.
- **Store idle tools out of reach of children and other untrained persons.** Tools are dangerous in the hands of untrained users.
- **When battery pack is not in use, keep it away from other metal objects like: paper clips, coins, keys, nails, screws, or other small metal objects that can make a connection from one terminal to another.** Shorting the battery terminals together may cause sparks, burns, or a fire.

- **Maintain tools with care. Keep cutting tools sharp and clean.** Properly maintained tools, with sharp cutting edges are less likely to bind and are easier to control.
- **Check for misalignment or binding of moving parts, breakage of parts, and any other condition that may affect the tool's operation. If damaged, have the tool serviced before using.** Many accidents are caused by poorly maintained tools.
- **Use only accessories that are recommended by the manufacturer for your model.** Accessories that may be suitable for one tool, may create a risk of injury when used on another tool.

Service

- **Tool service must be performed only by qualified repair personnel.** Service or maintenance performed by unqualified personnel could result in a risk of injury.
- **When servicing a tool, use only identical replacement parts. Follow instructions in the Maintenance section of this manual.** Use of unauthorized parts or failure to follow Maintenance Instructions may create a risk of shock or injury.

SPECIFIC SAFETY RULES AND/OR SYMBOLS

Hold tool by insulated gripping surfaces when performing an operation where the cutting tool may contact hidden wiring. Contact with a "live" wire will make exposed metal parts of the tool "live" and shock the operator.

Additional Rules For Safe Operation

- **Know your power tool. Read operator's manual carefully. Learn its applications and limitations, as well as the specific potential hazards related to this tool.** Following this rule will reduce the risk of electric shock, fire, or serious injury.
- **Make sure your extension cord is in good condition. When using an extension cord, be sure to use one heavy enough to carry the current your product will draw. A wire gage size (A.W.G.) of at least 16 is recommended for an extension cord 100 feet or less in length. A cord exceeding 100 feet is not recommended. If in doubt, use the next heavier gage. The smaller the gage number, the heavier the cord. An undersized cord will cause a drop in line voltage resulting in loss of power and overheating.**

Important Rules for Battery Tools

- **Battery tools do not have to be plugged into an electrical outlet; therefore, they are always in operating condition. Be aware of possible hazards when not using your battery tool or when chang-**

ing accessories. Following this rule will reduce the risk of electric shock, fire, or serious personal injury.

- **Do not place battery tools or their batteries near fire or heat. They may explode.** Following this rule will reduce the risk of electric shock, fire, or serious personal injury.
- **Do not charge battery tool in a damp or wet location.** Following this rule will reduce the risk of electric shock, fire, or serious personal injury.
- **Your battery tool should be charged in a location where the temperature is more than 50°F but less than 100°F.** Following this rule will reduce the risk of electric shock, fire, or serious personal injury.
- **Under extreme usage or temperature conditions, battery leakage may occur. If liquid comes in contact with your skin, wash immediately with soap and water, then neutralize with lemon juice or vinegar. If liquid gets into your eyes, flush them with clean water for at least 10 minutes, then seek immediate medical attention.** Following this rule will reduce the risk of serious personal injury.

SPECIFIC SAFETY RULES AND/OR SYMBOLS

Important Safety Instructions For Charger

- **Save these instructions. This manual contains important safety and operating instructions for battery charger item number 9-11040 (981399-001).**

Following this rule will reduce the risk of electric shock, fire, or serious personal injury.

- **Before using battery charger, read all instructions and cautionary markings in this manual, on battery charger, and product using battery charger.** Following this rule will reduce the risk of electric shock, fire, or serious personal injury.
- **To reduce risk of injury, charge only nickel-cadmium and nickel metal hydride type rechargeable batteries. Other types of batteries may burst causing personal injury and damage.** Following this rule will reduce the risk of electric shock, fire, or serious personal injury.
- **Do not expose charger to rain or snow.** Following this rule will reduce the risk of electric shock, fire, or serious personal injury.
- **Use of an attachment not recommended or sold by the battery charger manufacturer may result in a risk of fire, electric shock, or injury to persons.** Following this rule will reduce the risk of electric shock, fire, or serious personal injury.
- **To reduce risk of damage to charger body and cord, pull by charger plug rather than cord when disconnecting charger.** Following this rule will reduce the risk of electric shock, fire, or serious personal injury.
- **Make sure cord is located so that it will not be stepped on, tripped over, or otherwise subjected to damage or stress.** Following this rule will reduce the risk of serious personal injury.
- **An extension cord should not be used unless absolutely necessary.** Use of improper extension cord could result in a risk of fire and electric shock. If extension cord must be used, make sure:
 - a. That pins on plug of extension cord are the same number, size and shape as those of plug on charger.
 - b. That extension cord is properly wired and in good electrical condition; and

- c. That wire size is large enough for AC ampere rating of charger as specified below:

Cord Length (Feet)	25'	50'	100'
Cord Size (AWG)	16	16	16

Note: AWG = American Wire Gage

- **Do not operate charger with a damaged cord or plug. If damaged, have replaced immediately by a qualified serviceman.** Following this rule will reduce the risk of electric shock, fire, or serious personal injury.
 - **Do not operate charger if it has received a sharp blow, been dropped, or otherwise damaged in any way; take it to a qualified serviceman.** Following this rule will reduce the risk of electric shock, fire, or serious personal injury.
 - **Do not disassemble charger; take it to a qualified serviceman when service or repair is required. Incorrect reassembly may result in a risk of electric shock or fire.** Following this rule will reduce the risk of electric shock, fire, or serious personal injury.
 - **To reduce the risk of electric shock, unplug charger from outlet before attempting any maintenance or cleaning. Turning off controls will not reduce this risk.** Following this rule will reduce the risk of electric shock, fire, or serious personal injury.
 - **Do not use charger outdoors.** Following this rule will reduce the risk of electric shock, fire, or serious personal injury.
 - **Disconnect charger from power supply when not in use.** Following this rule will reduce the risk of electric shock, fire, or serious personal injury.
-  **DANGER: RISK OF ELECTRIC SHOCK. DO NOT TOUCH UNINSULATED PORTION OF OUTPUT CONNECTOR OR UNINSULATED BATTERY TERMINAL.**
- **Save these instructions. Refer to them frequently and use them to instruct others who may use this tool. If you loan someone this tool, loan them these instructions also.** Following this rule will reduce the risk of electric shock, fire, or serious personal injury.

SYMBOLS

SYMBOL	NAME	DESIGNATION/EXPLANATION
V	Volts	Voltage
A	Amperes	Current
Hz	Hertz	Frequency (cycles per second)
min	Minutes	Time
~	Alternating Current	Type or a characteristic of current
==	Direct Current	Type or a characteristic of current
n_0	No Load Speed	Rotational speed, at no load
.../min	Revolutions or Reciprocation Per Minute	Revolutions, strokes, surface speed, orbits etc. per minute
	Safety Alert Symbol	Indicates danger, warning or caution. It means attention!!! Your safety is involved.

FEATURES

DEFINITIONS

- A) **DANGER:** Failure to obey a safety warning will result in serious injury to yourself or to others. Always follow the safety precautions to reduce the risk of fire, electric shock and personal injury.
- B) **WARNING:** Failure to obey a safety warning can result in serious injury to yourself or to others. Always follow the safety precautions to reduce the risk of fire, electric shock and personal injury.
- C) **CAUTION:** Failure to obey a safety warning may result in property damage or personal injury to yourself or to others. Always follow the safety precautions to reduce the risk of fire, electric shock and personal injury.
- D) **NOTE:** Advises you of information or instructions vital to the operation or maintenance of the equipment.

FEATURES

KNOW YOUR DRILL-DRIVER

See Figure 1.

Before attempting to use your drill-driver, familiarize yourself with all operating features and safety requirements.

⚠ WARNING: Carefully read through this entire owner's manual before using your new drill-driver. Pay close attention to the Rules For Safe Operation, Warnings and Cautions. If you use your drill-driver properly and only for what it is intended, you will enjoy years of safe, reliable service.

⚠ WARNING: Do not allow familiarity with your drill-driver to make you careless. Remember that a care-less fraction of a second is sufficient to inflict severe injury.

KEYLESS CHUCK

Your drill-driver has a keyless chuck that allows you to hand tighten or release drill bit in the chuck jaws.

SWITCH

To turn your drill-driver **ON**, depress the switch trigger. Release switch trigger to turn your drill-driver **OFF**.

SWITCH LOCK

The switch trigger can be locked in the **OFF** position. This feature helps reduce the possibility of accidental starting when not in use.

VARIABLE SPEED

This tool has a variable speed switch that delivers higher speed with increased trigger pressure. Speed is controlled by the amount of switch trigger depression.

TWO SPEED GEAR TRAIN

Your drill-driver has a two speed gear train designed for drilling or driving at **HI** or **LO** speeds. A slide switch is located on top of your drill to select either **HI** or **LO** speed.

FORWARD/REVERSE SELECTOR (DIRECTION OF ROTATION SELECTOR)

Your drill-driver has a forward/reverse selector located above the switch trigger.

WRIST STRAP

A wrist strap is provided to reduce the chances of dropping your drill-driver. Place one hand through the wrist strap when carrying tool.

BIT STORAGE

When not in use, bits provided with your drill-driver can be placed in the storage area located on the top of the motor housing.

LEVEL

To keep drill bit level during drilling operations, a level is located on the top and end of the motor housing.

⚠ WARNING: If any parts are missing, do not operate your drill-driver until the missing parts are replaced. Failure to do so could result in possible serious personal injury.

PRODUCT SPECIFICATIONS:

DRILL-DRIVER	973.271600
Chuck	3/8 in. Keyless
Motor	DC Motor 15.6 Volt
Gear Train	Two Speed
Switch	Variable Speed
No Load Speed	0-400 RPM (Low) 0-1400 RPM (High)
Clutch	24 Positions
Maximum Torque	380 in./lbs.
CHARGER	ITEM NO. 9-11040 (981399-001)
Input	120 V, 60 Hz, AC only
Charging Voltage	9.6 - 24 Volt
Charge Rate	1 Hour
BATTERY PACK	ITEM NO. 9-11022 (981956-001)

FEATURES

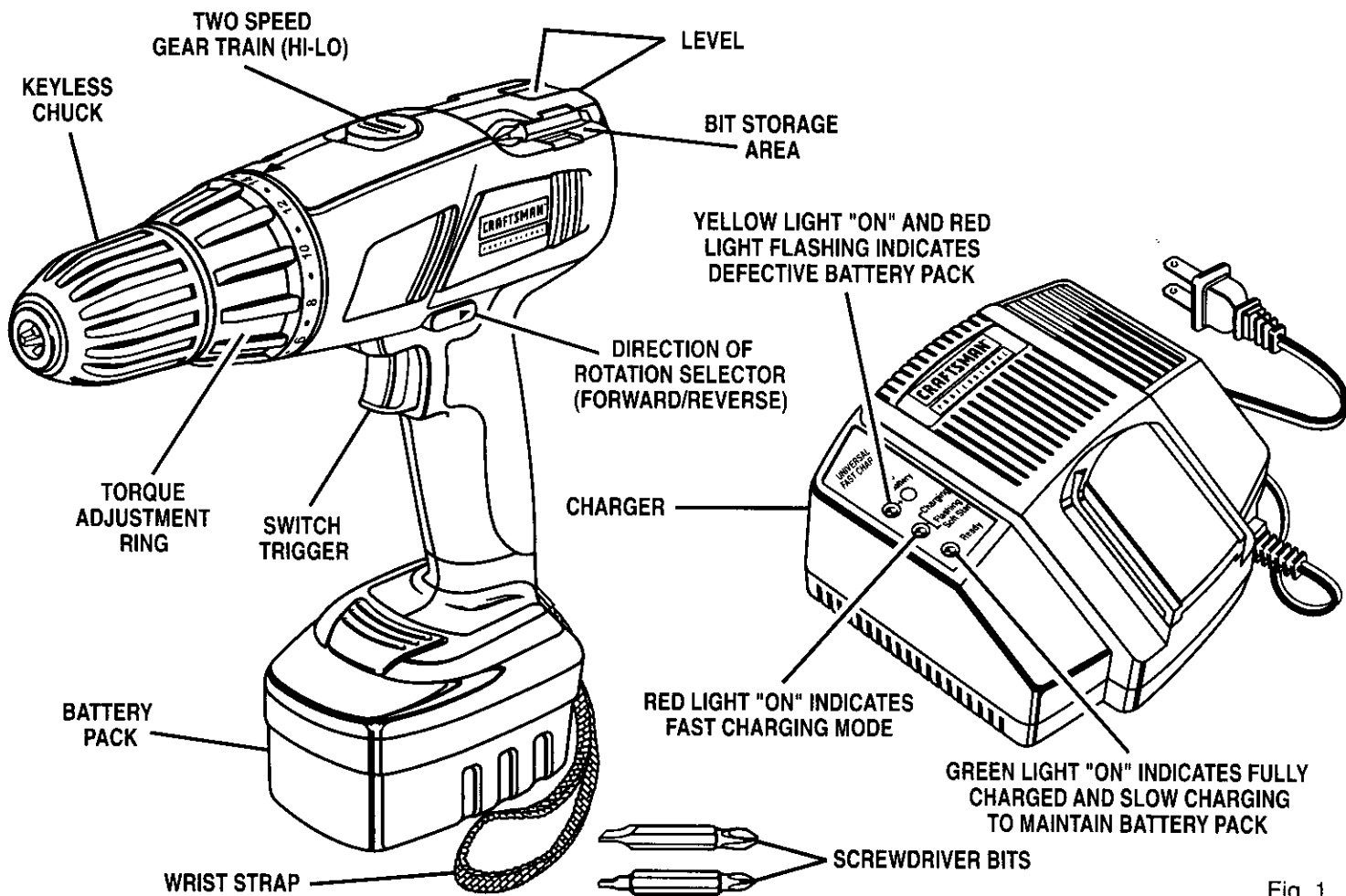

Fig. 1

CHARGER

See Figure 2.

Your charger has a "key hole" hanging feature for convenient, space saving storage. Screws should be installed so that center distances are 4-1/8 inches apart.

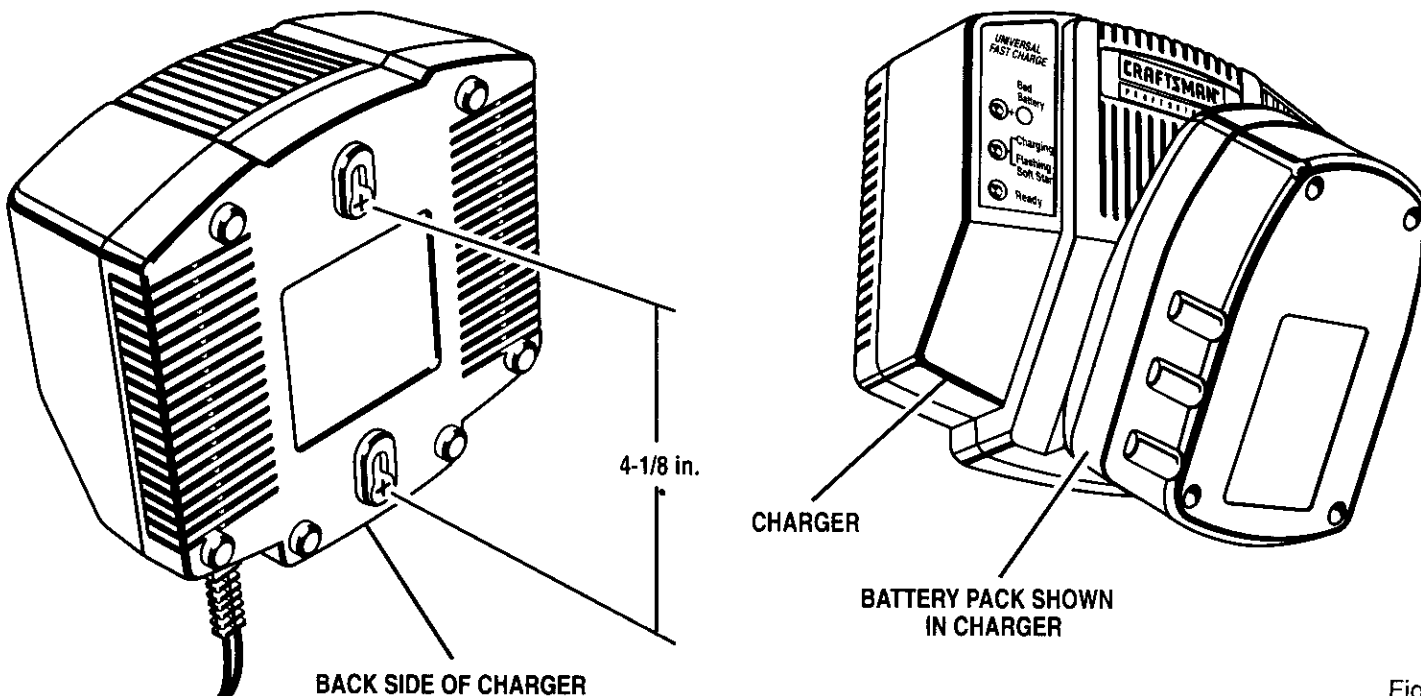

Fig. 2

ASSEMBLY

INSTALLING BITS

See Figure 3.

- Lock the switch trigger by placing the direction of rotation selector in center position. See Figure 10.
- Open or close chuck jaws to a point where the opening is slightly larger than the bit size you intend to use. Also, raise the front of your drill slightly to keep the bit from falling out of the chuck jaws.
- Insert drill bit into chuck the full length of the jaws as shown in Figure 3.

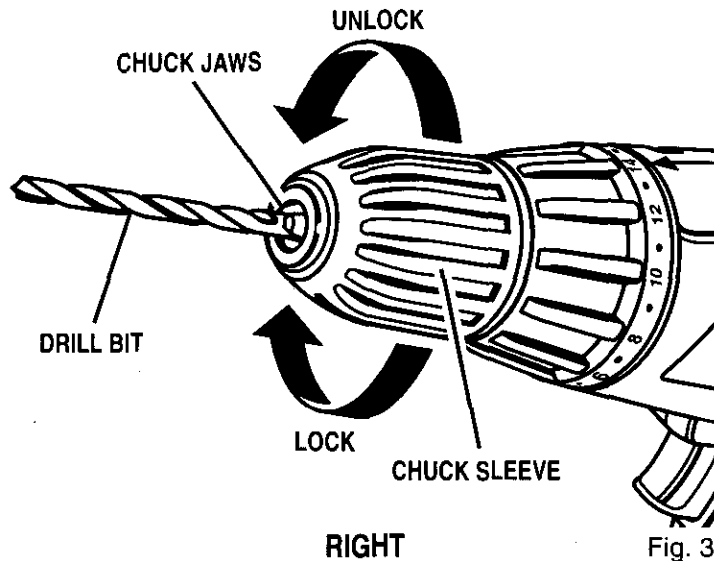

- Tighten the chuck jaws on drill bit. To tighten, grasp and hold the drill with one hand, while rotating the chuck sleeve with your other hand.
Note: Rotate the chuck sleeve in the direction of the arrow marked **LOCK** to tighten chuck jaws.
- **Do not** use a wrench to tighten or loosen the chuck jaws.

⚠ WARNING: Do not insert drill bit into chuck jaws and tighten as shown in Figure 4. This could cause drill bit to be thrown from drill resulting in possible serious personal injury or damage to the chuck.

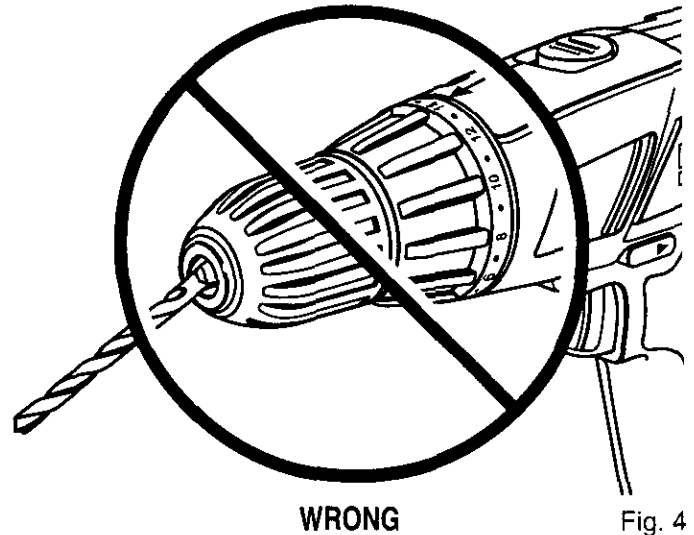

REMOVING BITS

See Figure 3.

- Lock the switch trigger by placing the direction of rotation selector in center position. See Figure 10.
- Loosen the chuck jaws from drill bit.
- To loosen, grasp and hold the drill with one hand, while rotating chuck sleeve with your other hand.
Note: Rotate chuck sleeve in the direction of the arrow marked **UNLOCK** to loosen the chuck jaws.
- **Do not** use a wrench to tighten or loosen the chuck jaws.
- Remove drill bit from chuck jaws.

ASSEMBLY

TO ATTACH BATTERY PACK TO DRILL

See Figure 5.

Note: Battery pack is shipped in a low charge condition. Therefore, it must be charged prior to use. Refer to page 10, "CHARGING BATTERY PACK" for charging instructions.

- Lock the switch trigger by placing the direction of rotation selector in center position. See Figure 10.
- Align raised ribs on battery pack with grooves on bottom of drill, then attach battery pack to drill as shown in Figure 5.
- Make sure latch on battery pack snaps in place and battery pack is secured to drill before beginning operation.

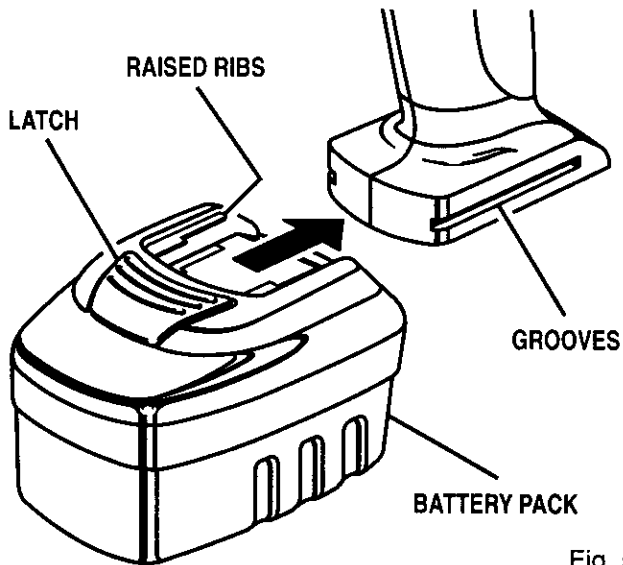

Fig. 5

CAUTION: When attaching battery pack to your drill, be sure raised ribs and grooves align properly and latch snaps in place properly. Improper assembly can cause damage to drill and battery pack.

TO REMOVE BATTERY PACK FROM DRILL

See Figure 6.

- Lock the switch trigger by placing the direction of rotation selector in center position. See Figure 10.
- Depress latch located on front of battery pack (1) to release battery pack.
- Pull forward on battery pack (2) to remove from drill.

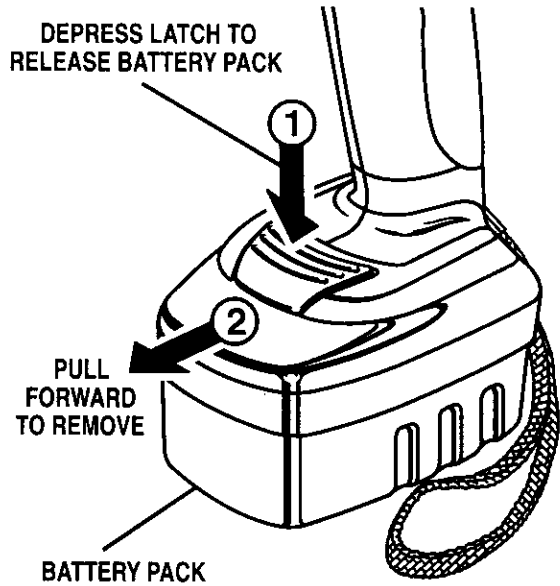

Fig. 6

OPERATION

⚠ WARNING: Always wear safety goggles or safety glasses with side shields when operating tools. Failure to do so could result in objects being thrown into your eyes, resulting in possible serious injury.

CHARGING BATTERY PACK

The battery pack for this tool has been shipped in a low charge condition to prevent possible problems. Therefore, you should charge it until light on front of charger changes from red to green.

Note: Batteries will not reach full charge the first time they are charged. Allow several cycles (drilling followed by recharging) for them to become fully charged.

TO CHARGE

- Charge battery pack only with the charger provided.
- **Make sure power supply is normal house voltage, 120 volts, 60 Hz, AC only.**
- Connect charger to power supply.
- Attach battery pack to charger by aligning raised ribs on battery pack with grooves in charger, then slide battery back onto charger. See Figure 7.

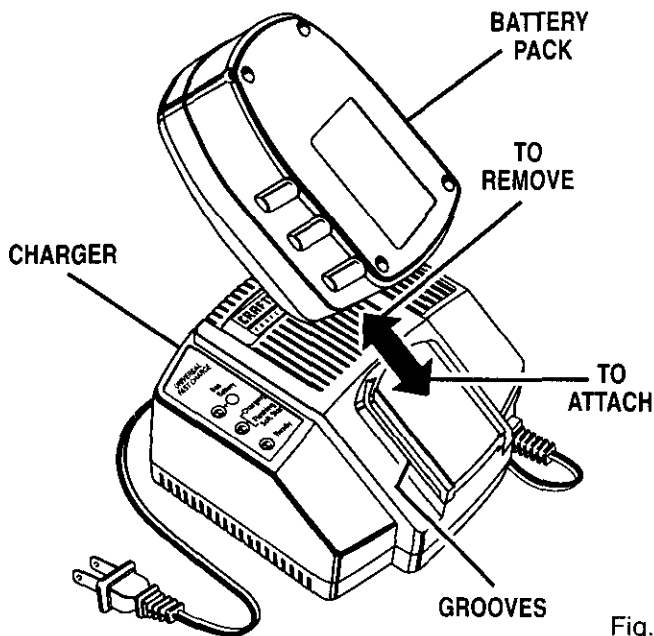

Fig. 7

- Red light should turn on. Red light indicates fast charging mode.
If red light is flashing, this indicates battery pack is deeply discharged or hot.
If battery pack is hot, red light should become steady after battery pack has cooled down.
If battery pack is deeply discharged, red light should become steady after voltage has increased, normally within 60 minutes.

If after one hour red light is still flashing, this indicates a defective battery pack and should be replaced.

Green light on indicates battery pack is fully charged and slow charging to maintain battery pack.

Yellow light on and red light flashing indicates defective battery pack. Return battery pack to your nearest Sears Repair Center for checking or replacing.

- When your battery pack becomes fully charged, the red light will turn **OFF** and the green light will turn **ON**.
- After normal usage, 1 hour of charging time is required to be fully charged. A minimum charge time of 1-1/2 hours is required to recharge a completely discharged tool.
- The battery pack will become slightly warm to the touch while charging. This is normal and does not indicate a problem.
- **Do not** place charger in an area of extreme heat or cold. It will work best at normal room temperature.
- When the batteries become fully charged, unplug your charger from power supply and remove the battery pack.

LED FUNCTION OF CHARGER

LED WILL BE LIGHTED TO INDICATE STATUS OF CHARGER AND BATTERY PACK:

- Red LED Lighted = Fast Charging Mode.
- Green LED Lighted = Fully Charged And Slow Charging To Maintain Battery Pack.
- Red LED Flashing = Hot Or Deeply Discharged Battery Pack. Also Defective Battery Pack After 1 Hour.
- Yellow LED Lighted and Red LED Flashing = Defective Battery Pack.

IMPORTANT INFORMATION FOR RECHARGING HOT BATTERIES

Under extreme continuous use, the batteries in your battery pack will become hot. You should let a hot battery pack cool down for approximately 1 hour before attempting to recharge. When the battery pack becomes discharged and is hot, this will cause the red light on your battery charger to flash. When battery pack cools down, red light will glow continuously indicating fast charging mode, 1 hour charge time. Once the battery pack cools down, it will recharge battery pack in fast charging mode as normal.

Note: This situation only occurs when extreme continuous use of your drill causes the batteries to become hot. **It does not occur under normal circumstances.** Refer to "CHARGING BATTERY PACK" for normal recharging of batteries. If the charger does not charge your battery pack under normal circumstances, return **both** the battery pack and charger to your nearest Sears repair center for electrical check.

OPERATION

SWITCH

See Figure 8.

To turn your drill **ON**, depress the switch trigger. To turn it **OFF**, release the switch trigger.

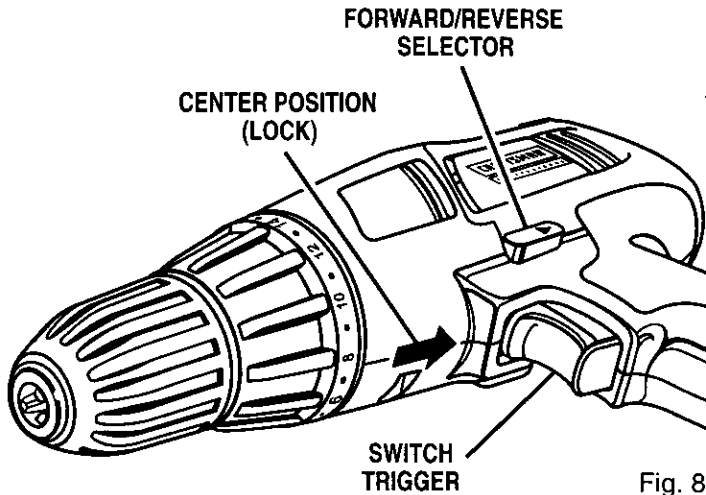

Fig. 8

VARIABLE SPEED

This tool has a variable speed switch that delivers higher speed and torque with increased trigger pressure. Speed is controlled by the amount of switch trigger depression.

Note: You might hear a whistling or ringing noise from the switch during use. Do not be concerned, this is a normal part of the switch function.

TWO SPEED GEAR TRAIN

See Figure 9.

Your drill has a two-speed gear train designed for drilling or driving at **LO (1)** or **HI (2)** speeds. A slide switch is located on top of your drill to select either **LO (1)** or **HI (2)** speed. When using drill in the **LO (1)** speed range, speed will decrease and unit will have more power and torque. When using drill in the **HI (2)** speed range, speed will increase and unit will have less power and torque. Use **LO (1)** speed for high power and torque applications and **HI (2)** speed for fast drilling or driving applications.

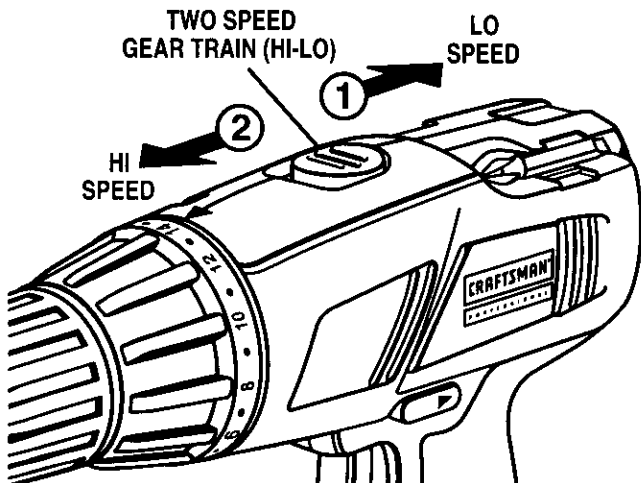

Fig. 9

SWITCH LOCK

See Figure 10.

The switch trigger can be locked in the **OFF** position. This feature can be used to prevent the possibility of accidental starting when not in use. To lock switch trigger, place the direction of rotation selector in center position.

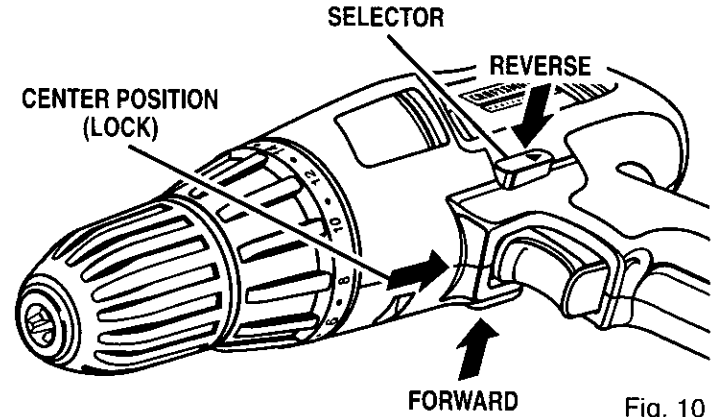

Fig. 10

WARNING: Battery tools are always in operating condition. Therefore, switch should always be locked when not in use or carrying at your side.

REVERSIBLE

See Figure 10.

This tool has the feature of being reversible. The direction of rotation is controlled by a selector located above the switch trigger. With the drill held in normal operating position, the direction of rotation selector should be positioned to the left of the switch for drilling. The drilling direction is reversed when the selector is to the right of the switch. When the selector is in center position, the switch trigger is locked.

CAUTION: To prevent gear damage, always allow chuck to come to a complete stop before changing the direction of rotation or the two speed gear train (hi-lo).

To stop, release switch trigger and allow the chuck to come to a complete stop.

OPERATION

KEYLESS CHUCK

See Figure 11.

A keyless chuck has been provided with your drill to allow for easy installation and removal of bits. As the name implies, you can hand tighten or release drill bits in the chuck jaws. Arrows on the chuck indicate which direction to rotate the chuck sleeve in order to **LOCK** (tighten) or **UNLOCK** (release) the chuck jaws. Loosen the chuck sleeve by rotating it counterclockwise with one hand. Insert drill bit into the chuck the full length of the jaws, tighten securely by rotating the chuck sleeve in clockwise direction.

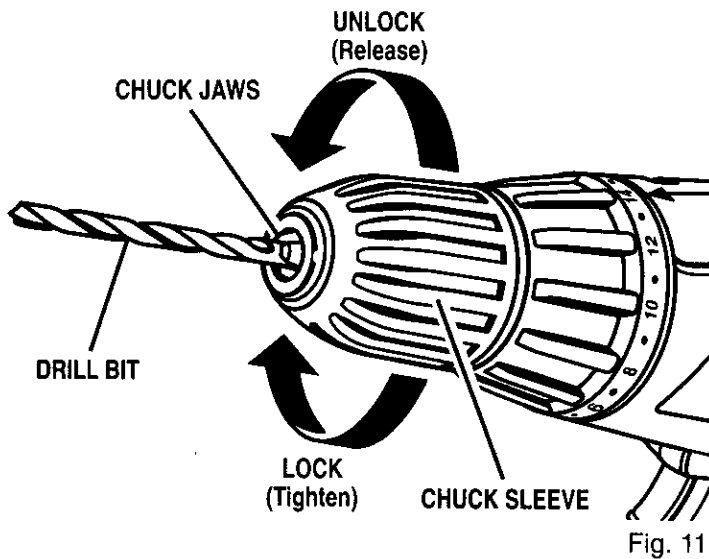

WARNING: Do not hold chuck sleeve with one hand and use power of the drill to tighten chuck jaws on drill bit. Chuck sleeve could slip in your hand or your hand could slip and come in contact with rotating drill bit. This could cause an accident resulting in serious personal injury.

ADJUSTABLE TORQUE CLUTCH

Your drill is equipped with an adjustable torque clutch for driving different types of screws into different materials. The proper setting depends on the type of material and the size of screw you are using.

TO ADJUST TORQUE

- Identify the twenty four torque indicator settings located on the front of your drill. See Figure 12.
- Rotate adjusting ring to the desired setting.
 - 1 - 4 For driving small screws.
 - 5 - 8 For driving screws into soft material.
 - 9 - 12 For driving screws into soft and hard materials.
 - 13 - 16 For driving screws in hard wood.
 - 17 - 20 For driving large screws.
 - 21 -  For heavy drilling.

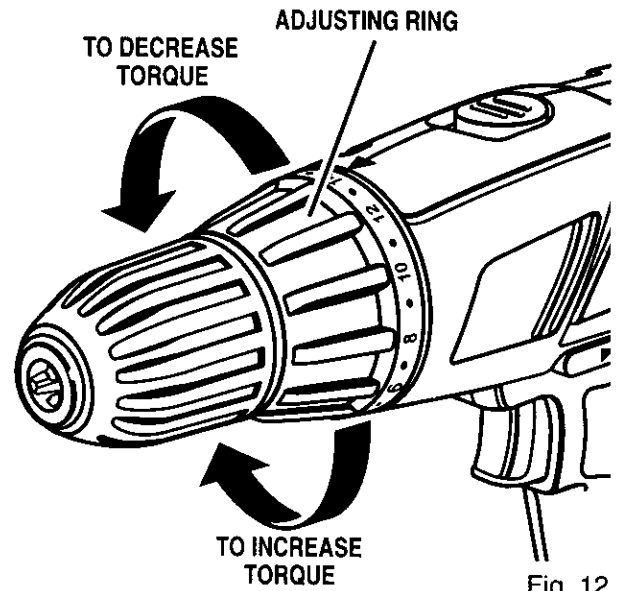

Note: Remember the two-speed feature (**HI-LO**) when setting torque. The amount of torque will vary depending on which speed setting you have your drill-driver. Switching to **LO** speed will increase torque. Switching to **HI** speed will decrease torque.

BIT STORAGE

See Figure 13.

When not in use, bits provided with your drill can be placed in the storage area located on the top of your drill as shown in Figure 13.

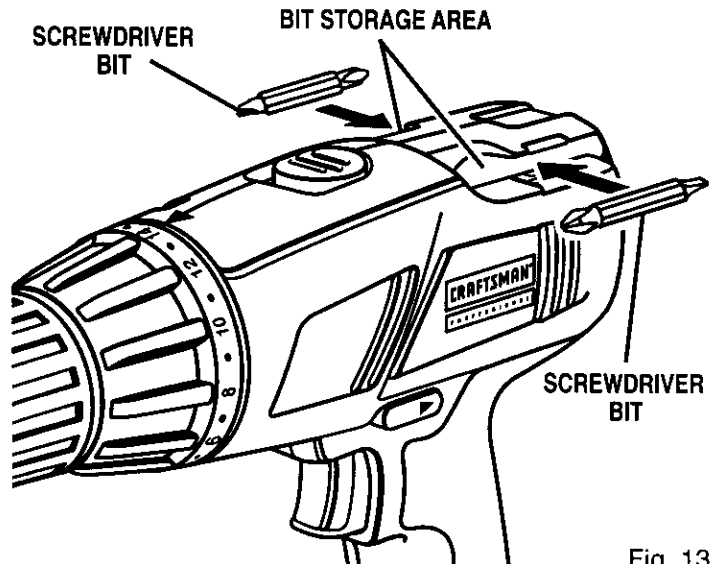

OPERATION

APPLICATIONS

(Use drill-driver only for the purpose listed below)

- Drilling in wood.
- Drilling in ceramics, plastics, fiberglass, and laminates.
- Drilling in both hard and soft metals.
- Using driving accessories, such as driving screws with screwdriver bits.
- Mixing paints.

LEVEL DRILLING

See Figure 14.

A convenient feature provided on your drill is a level. It is recessed in the motor housing on top and end of your drill. It can be used to keep drill bits level during most drilling operations.

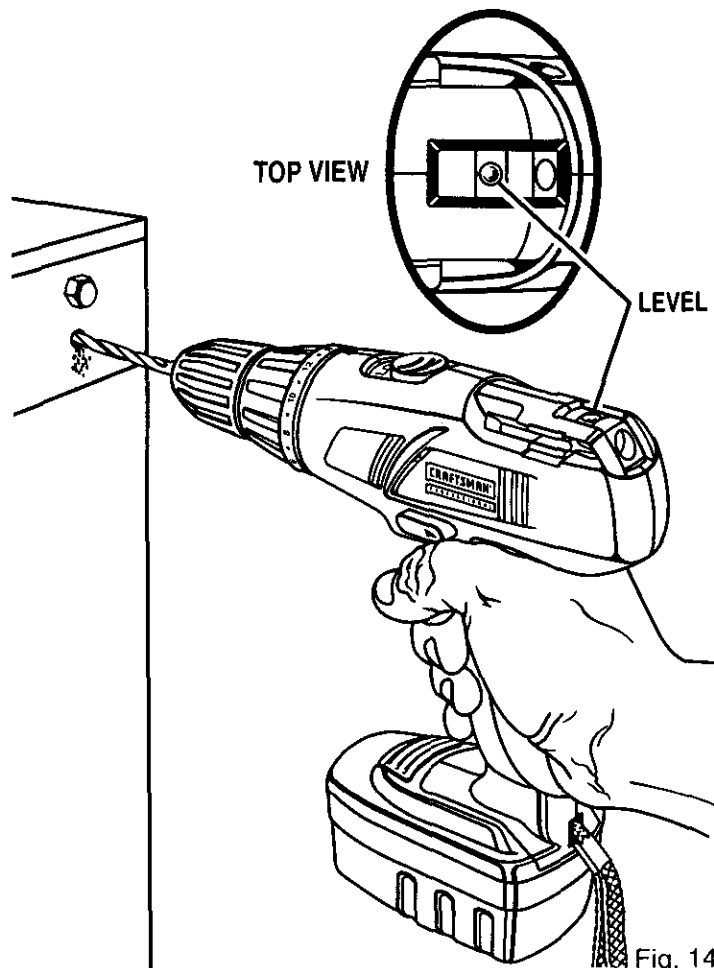

DRILLING

See Figure 15.

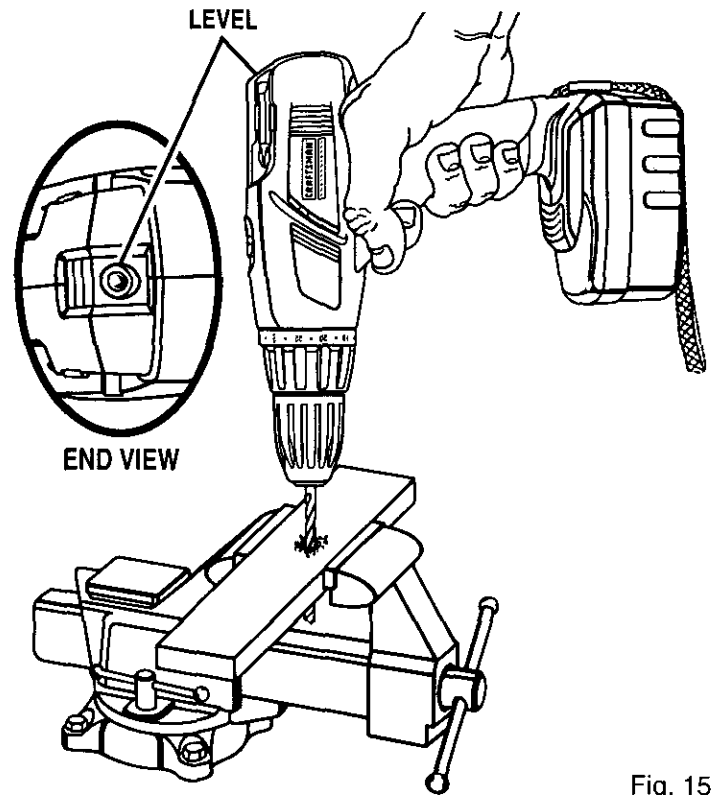

Fig. 15

When drilling hard smooth surfaces use a center punch to mark desired hole location. This will prevent the drill bit from slipping off center as the hole is started. However, the low speed feature allows starting holes without center punching if desired. To accomplish this, simply operate your drill at a low speed until the hole is started.

The material to be drilled should be secured in a vise or with clamps to keep it from turning as the drill bit rotates. Hold tool firmly and place the bit at the point to be drilled. Depress the switch trigger to start tool.

Move the drill bit into the workpiece applying only enough pressure to keep the bit cutting. Do not force or apply side pressure to elongate a hole.

⚠ WARNING: Be prepared for binding or bit breakthrough. When these situations occur, drill has a tendency to grab and kick opposite to the direction of rotation and could cause loss of control when breaking through material. If not prepared, this loss of control can result in possible serious injury.

When drilling metals, use a light oil on the drill bit to keep it from overheating. The oil will prolong the life of the bit and increase the drilling action.

If the bit jams in workpiece or if the drill stalls, release switch trigger immediately. Remove the bit from the workpiece and determine the reason for jamming.

OPERATION

CHUCK REMOVAL

See Figures 16, 17, and 18.

The chuck must be removed in order to use some accessories. To remove:

- Lock the switch trigger by placing the direction of rotation selector in center position. See Figure 10.
- Insert a 5/16 inch or larger hex key wrench into the chuck of your drill and tighten the chuck jaws securely.
- Tap the hex key wrench sharply with a mallet in a clockwise direction. See Figure 16. This will loosen the screw in the chuck for easy removal.

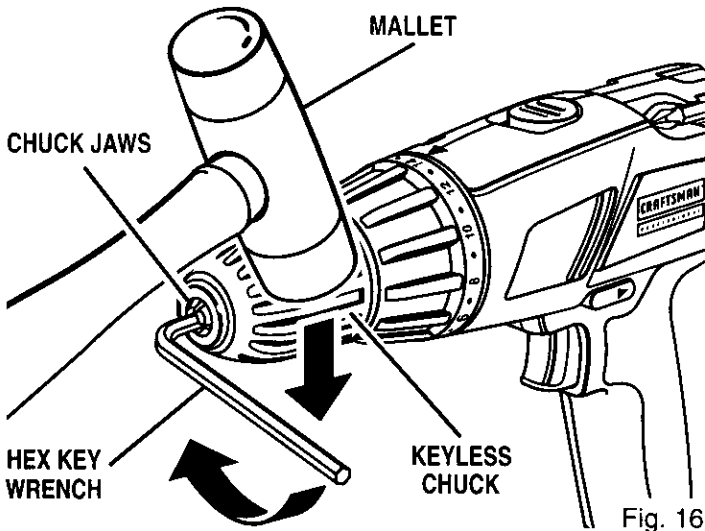

- Open chuck jaws and remove hex key wrench. Remove the chuck screw by turning it in a clockwise direction. See Figure 17.

Note: The screw has left hand threads.

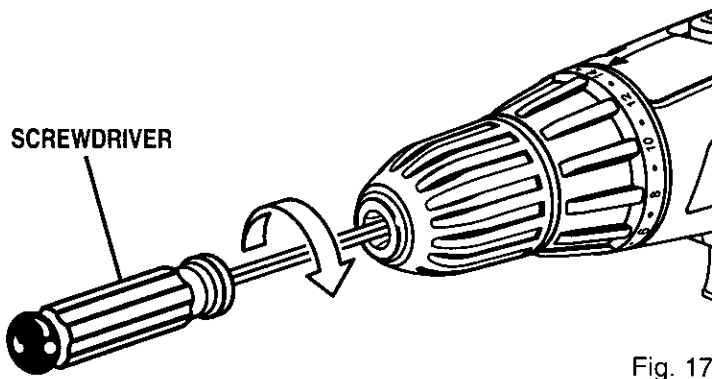

- Insert hex key wrench in chuck and tighten chuck jaws securely. Tap sharply with a mallet in a counter-clockwise direction. This will loosen chuck on the spindle. It can now be unscrewed by hand. See Figure 18.

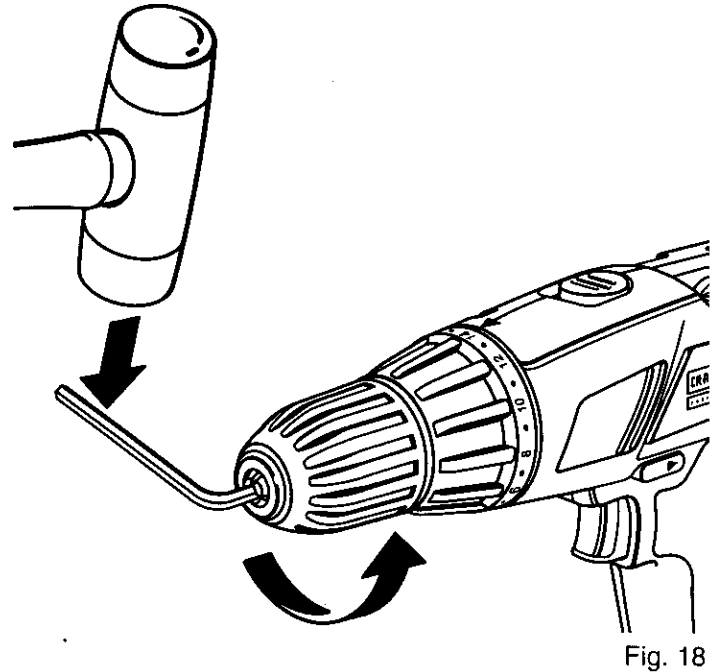

TO RETIGHTEN A LOOSE CHUCK

The chuck may become loose on spindle and develop a wobble. Also, the chuck screw may become loose causing the chuck jaws to bind and prevent them from closing. To tighten, follow these steps:

- Lock the switch trigger by placing the direction of rotation selector in center position. See Figure 10.
- Insert hex key wrench into chuck and tighten chuck jaws securely. Tap hex key wrench sharply with a mallet in a clockwise direction. This will tighten chuck on the spindle.
- Open the chuck jaws and remove hex key wrench.
- Tighten the chuck screw.

Note: The chuck screw has left hand threads.

MAINTENANCE

⚠ WARNING: When servicing use only identical Craftsman replacement parts. Use of any other parts may create a hazard or cause product damage.

Avoid using solvents when cleaning plastic parts. Most plastics are susceptible to damage from various types of commercial solvents and may be damaged by their use. Use clean cloths to remove dirt, carbon dust, etc.

⚠ WARNING: Do not at any time let brake fluids, gasoline, petroleum-based products, penetrating oils, etc. come in contact with plastic parts. They contain chemicals that can damage, weaken, or destroy plastic.

Do not abuse power tools. Abusive practices can damage tool as well as workpiece.

Only the parts shown on parts list, page 17, are intended to be repaired or replaced by the customer. All other parts should be replaced by a qualified service technician at an authorized service facility.

⚠ WARNING: Do not attempt to modify this tool or create accessories not recommended for use with this tool. Any such alteration or modification is misuse and could result in a hazardous condition leading to possible serious personal injury.

BATTERIES

The battery pack for your drill-driver is equipped with nickel-cadmium rechargeable batteries. Length of service from each charging will depend on the type of work you are doing.

The batteries in this tool have been designed to provide maximum trouble free life. However, like all batteries, they will eventually wear out. **Do not** disassemble battery pack and attempt to replace the batteries. Handling of these batteries, especially when wearing rings and jewelry, could result in a serious burn.

To obtain the longest possible battery life, we suggest the following:

- Store and charge your batteries in a cool area. Temperatures above normal room temperature will shorten battery life.
- Never store batteries in a discharged condition. Recharge them immediately after they are discharged.
- All batteries gradually lose their charge. The higher the temperature the quicker they lose their charge. If you store your tool for long periods of time without using it, recharge the batteries every month or two. This practice will prolong battery life.



To preserve natural resources, please recycle or dispose of properly.

This product contains nickel-cadmium batteries. Local, state or federal laws may prohibit disposal of nickel-cadmium batteries in ordinary trash.

Consult your local waste authority for information regarding available recycling and/or disposal options.

BATTERY PACK REMOVAL AND PREPARATION FOR RECYCLING

⚠ WARNING: Upon removal, cover the battery pack's terminals with heavy duty adhesive tape. Do not attempt to destroy or disassemble battery pack or remove any of its components. Nickel-cadmium batteries must be recycled or disposed of properly. Also, never touch both terminals with metal objects and/or body parts as short circuit may result. Keep away from children. Failure to comply with these warnings could result in fire and/or serious injury.

OVERLOAD

Your drill has a built-in overload protector to protect the motor during overloading or prolonged use. The overload protector automatically activates to break the circuit. When this occurs, allow your drill to cool a few seconds before resuming operation.

ACCESSORIES

The following recommended accessories are currently available at Sears Retail Stores.

- 6-Pc. Extra Length Magnite Power Bit Set
- 17-Pc. Power Screwdriver/Nutdriver Set and Case
- 30-Pc. Power Screwdriver/Nutdriver Set and Case
- High Speed Bits (For Wood or Metal).....3/4 in. Max.

⚠ WARNING: The use of attachments or accessories not listed might be hazardous.

⚠ WARNING:



The operation of any power tool can result in foreign objects being thrown into your eyes, which can result in severe eye damage. Before beginning power tool operation, always wear safety goggles or safety glasses with side shields and a full face shield when needed. We recommend Wide Vision Safety Mask for use over eyeglasses or standard safety glasses with side shields, available at Sears Retail Stores.

WARRANTY

FULL ONE YEAR WARRANTY ON **CRAFTSMAN** PROFESSIONAL CORDLESS DRILL-DRIVER

If this **CRAFTSMAN** Professional Cordless Drill-Driver fails due to a defect in material or workmanship within one year from the date of purchase, Sears will repair it, free of charge.

WARRANTY SERVICE IS AVAILABLE BY SIMPLY RETURNING THE TOOL TO THE NEAREST SEARS STORE IN THE UNITED STATES.

This warranty gives you specific legal rights, and you may also have other rights which vary from state to state.

Sears, Roebuck and Co., Dept. 817 WA, Hoffman Estates, IL 60179

SAVE THESE INSTRUCTIONS

**CRAFTSMAN 3/8 in. PROFESSIONAL CORDLESS DRILL-DRIVER
MODEL NO. 973.271600**

The model number will be found on a plate attached to the motor housing. Always mention the model number in all correspondence regarding your **CRAFTSMAN 3/8 in. PROFESSIONAL CORDLESS DRILL-DRIVER** or when ordering repair parts.

SEE BACK PAGE FOR PARTS ORDERING INSTRUCTIONS

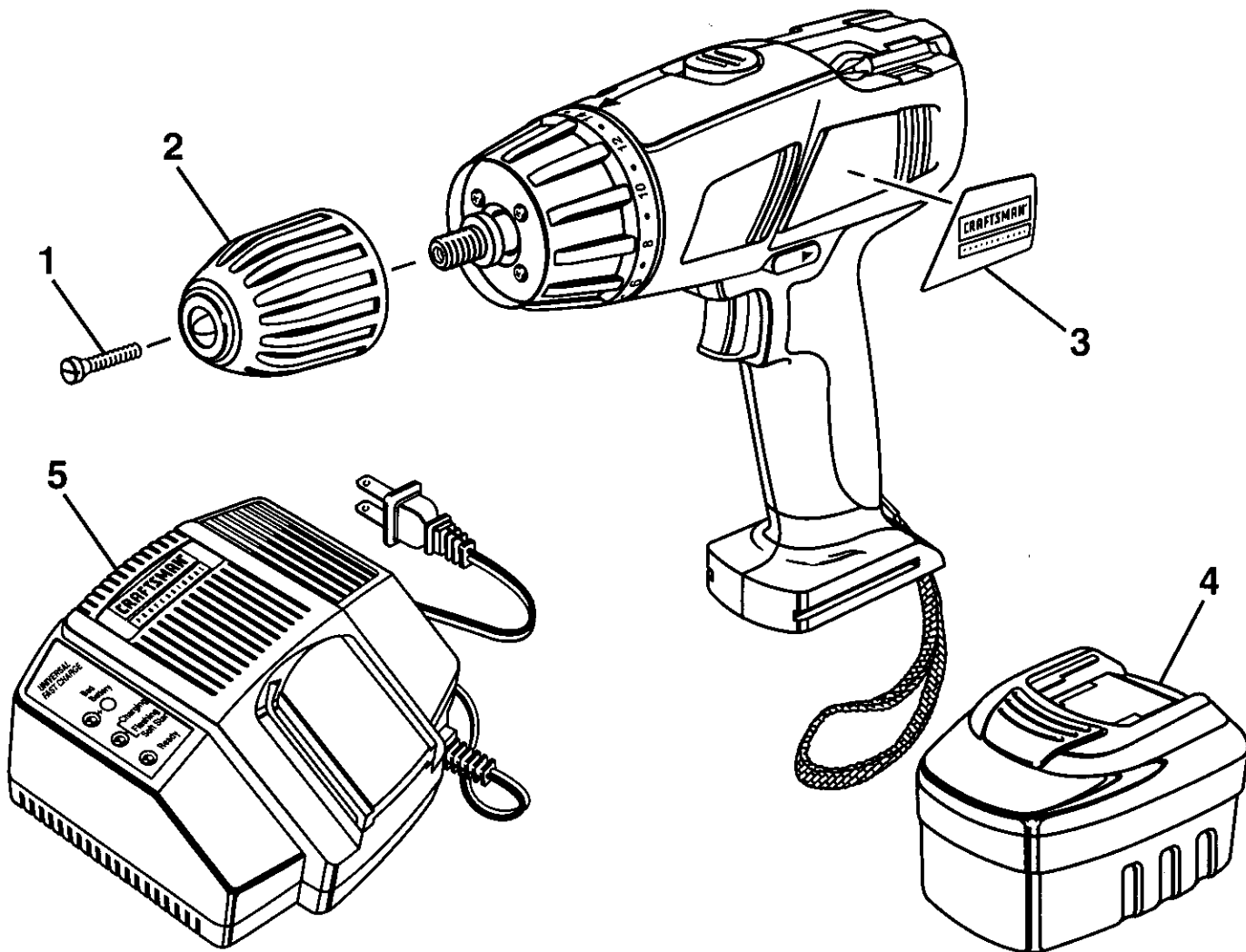

PARTS LIST

Key No.	Part Number	Description	Quan.
1	616478-003	Screw (Special)	1
2	981502-001	Chuck (Item No. 9-20955)	1
3	981501-001	Logo Plate	1
4	** 9-11022	Battery Pack (Includes Part No. 981956-001)	1
5	* 9-11040	Battery Charger (Includes Part No. 981399-001)	1
6	981500-001	Carrying Case – Not Shown	1
	972000-754	Owner's Manual	

* Can Be Purchased At Your Nearest Sears Retail Store

** Can Be Purchased Thru RSOS (Retail Special Order System)

CRAFTSMAN 3/8 INCH PROFESSIONAL CORDLESS DRILL-DRIVER - MODEL NUMBER 973.271600

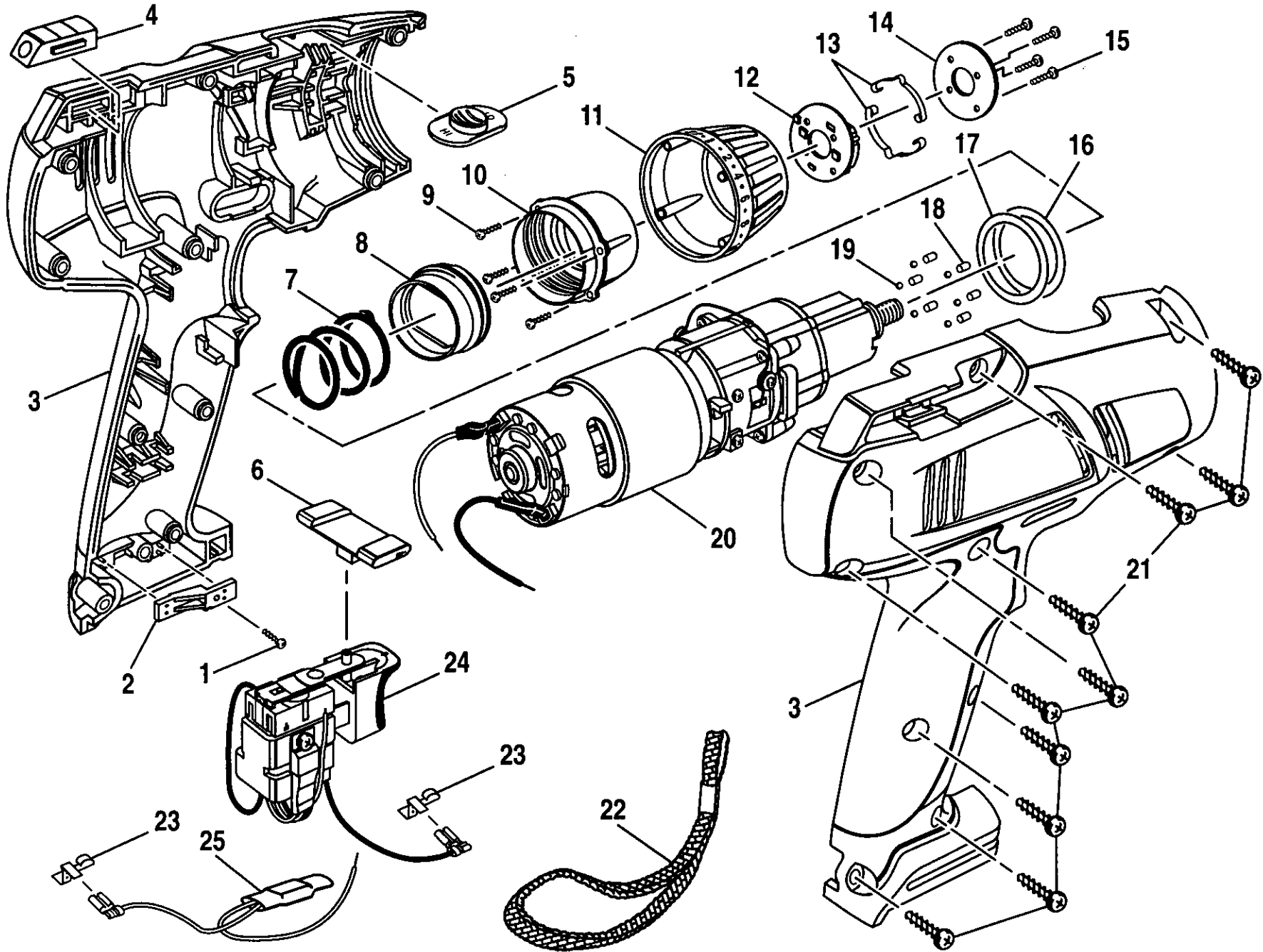

CRAFTSMAN 3/8 INCH PROFESSIONAL CORDLESS DRILL-DRIVER – MODEL NUMBER 973.271600

The model number will be found on a plate attached to the motor housing. Always mention the model number in all correspondence regarding your **3/8 INCH PROFESSIONAL CORDLESS DRILL-DRIVER** or when ordering repair parts.

PARTS LIST

KEY NO.	PART NUMBER	DESCRIPTION	QUAN.	KEY NO.	PART NUMBER	DESCRIPTION	QUAN.
1	981899-001	SCREW (M3 X 8 PLASTITE)	1	14	981507-001	MOUNTING PLATE	1
2	981745-001	CONTACT PLATE HOLDER	1	15	981900-001	* SCREW (M3 X 14 PAN HD.)	4
3	981904-002	HOUSING ASSEMBLY	1	16	981513-001	WASHER	1
4	981739-001	LEVEL	1	17	981733-001	WASHER	1
5	981746-001	GEAR TRAIN BUTTON	1	18	981735-001	PIN	6
6	981743-001	FORWARD/REVERSE SWITCH	1	19	981734-001	STEEL BALL	6
7	981897-001	SPRING	1	20	981738-001	MOTOR/GEAR BOX ASSEMBLY	1
8	981896-001	SLEEVE	1	21	981901-001	SCREW (M4 X 16 PLASTITE)	10
9	981898-001	* SCREW (M2.6 X 8 PAN HD.)	4	22	981495-001	WRIST STRAP	1
10	981510-001	CLUTCH CAP - INNER	1	23	981744-001	HOUSING CONTACT PLATE	2
11	981895-001	CLUTCH CAP - OUTER	1	24	981748-001	SWITCH ASSEMBLY (CAPAX)	1
12	981894-001	SPRING HOLDER	1	25	981747-001	THERMAL PROTECTOR	1
13	981753-001	SPRING PLATE	2		972000-754R	OWNER'S MANUAL	
					4-00		

* Standard Hardware Item – May Be Purchased Locally

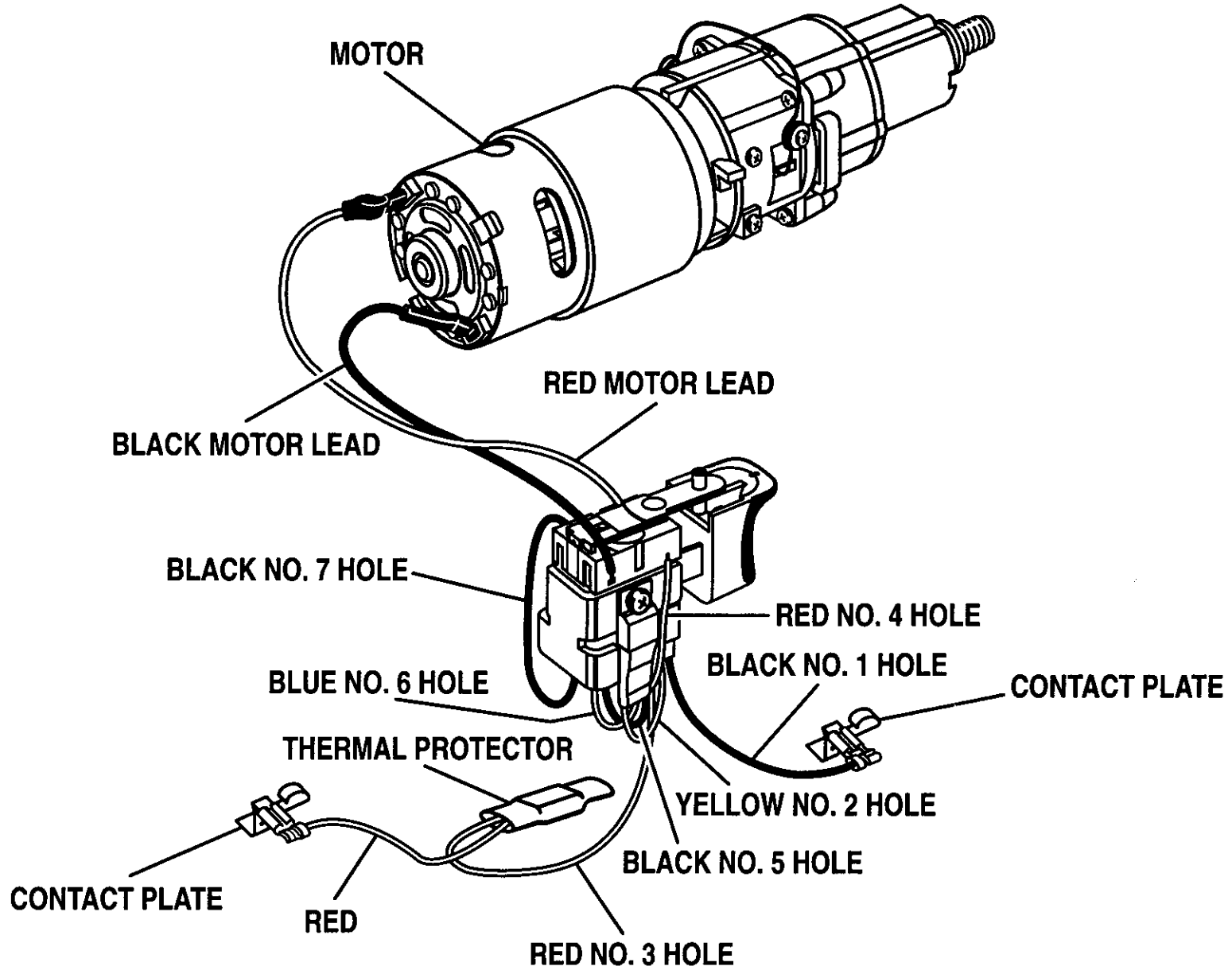

WIRING DIAGRAM

**In U.S.A. or Canada
for in-home major brand repair service:**

Call 24 hours a day, 7 days a week

1-800-4-MY-HOMESM (1-800-469-4663)

Para pedir servicio de reparación a domicilio – 1-800-676-5811

Au Canada pour tout le service ou les pièces – 1-800-469 4663

For the repair or replacement parts you need:

Call 6 a.m. – 11 p.m. CST, 7 days a week

Parts DirectSM

1-800-366-PART (1-800-366-7278)

Para ordenar piezas con entrega a domicilio – 1-800-659-7084

For the location of a Sears Service Center in your area:

Call 24 hours a day, 7 days a week

1-800-488-1222

To purchase or inquire about a Sears Maintenance Agreement:

Call 7 a.m. – 5 p.m. CST, Monday – Saturday

1-800-827-6655

