

SEARS

Model No.
919.670041

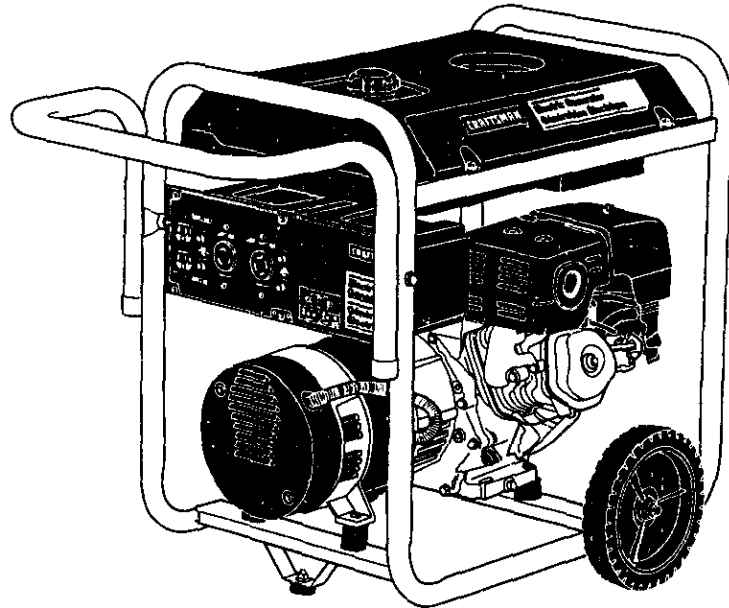

CRAFTSMAN

**120/240 VOLT • 4250 WATT
GENERATOR**

IMPORTANT:
Read the Safety Guidelines
and All Instructions Care-
fully Before Operating

- SAFETY GUIDELINES
- ASSEMBLY
- OPERATION
- MAINTENANCE
- TROUBLESHOOTING
- REPAIR PARTS

Sold by Sears Canada, Inc., Toronto, Ont. M5B2B8

TABLE OF CONTENTS

Warranty	2	Storage	19
Safety Guidelines	3-8	Troubleshooting Guide	19
Assembly	9-10	Generator Parts	20-26
Operation	11-15	Engine Parts	27-36
Maintenance	16-18	How To Order Parts	Back Cover
Service Adjustments	18		

DATE PURCHASED: _____

MODEL NO: _____

SERIAL NO: _____

STORE WHERE PURCHASED: _____

ADDRESS: _____

CITY: _____

TELEPHONE: _____

Record the above information about your unit so that you will be able to provide it in case of loss or theft.

HORSE POWER	9 HP
GASOLINE CAPACITY	7 GALLON/26.5 LITERS
OIL CAPACITY	37.1OZ./1.1 LITERS

MAINTENANCE AGREEMENT

The Sears Warranty, plus a Maintenance Agreement, provide maximum value for your Sears products. Contact your nearest Sears store for details.

CUSTOMER RESPONSIBILITIES

Read and observe the safety rules.

Follow a regular schedule in maintaining, caring for and using your generator.

Follow the instructions under "Customer Responsibilities" and "Storage" sections of this owner's manual.

FULL ONE YEAR WARRANTY ON CRAFTSMAN GENERATORS

For one year from the date of purchase, when this Craftsman generator is maintained and operated according to the instructions in this owner's manual, Sears will repair, free of charge, any defect in material and workmanship.

If your Craftsman Generator is used for commercial or rental purposes, this warranty applies for only 90 days from the original date of purchase.

FULL ONE YEAR WARRANTY ON CRAFTSMAN ENGINE

For one year from the date of purchase, when this Craftsman engine is maintained and operated according to the instructions in this owner's manual, Sears will repair, free of charge, any defect in material and workmanship.

If your Craftsman engine is used for commercial or rental purposes, this warranty applies only for 90 days from the date of purchase. This warranty does not cover: Expendable items such as spark plugs and air filters, which become worn during normal use.

Repairs necessary because of operator abuse or negligence, including damage resulting from no oil being supplied to the engine or failure to maintain the equipment according to the instructions contained in this owner's manual, are not covered under warranty.

WARRANTY SERVICE IS AVAILABLE BY RETURNING THE GENERATOR TO THE NEAREST SEARS SERVICE CENTER. This warranty gives you specific legal rights and you may also have other rights, which vary from PROVINCE TO PROVINCE.

Sold by Sears Canada, Inc., Toronto, Ont.

SAFETY GUIDELINES - DEFINITIONS

This manual contains information that is important for you to know and understand. This information relates to protecting **YOUR SAFETY** and **PREVENTING EQUIPMENT PROBLEMS**. To help you recognize this information, we use the symbols to the right. Please read the manual and pay attention to these sections.

⚠ DANGER	⚠ CAUTION
DANGER indicates an imminently hazardous situation which, if not avoided, will result in <u>death or serious injury</u> .	CAUTION indicates a potentially hazardous situation which, if not avoided, <u>may</u> result in <u>minor or moderate injury</u> .
⚠ WARNING	CAUTION
WARNING indicates a potentially hazardous situation which, if not avoided, <u>could</u> result in <u>death or serious injury</u> .	CAUTION used without the safety alert symbol indicates a potentially hazardous situation which, if not avoided, <u>may</u> result in <u>property damage</u> .

This product is not equipped with a spark arresting muffler. If the product will be used around flammable materials, or on land covered with materials such as agricultural crops, forest, brush, grass, or other similar items, then an approved spark arrester must be installed and may be legally required in other countries.

IMPORTANT SAFETY INSTRUCTIONS

- **SAVE THESE INSTRUCTIONS** •

⚠ WARNING

When using this product basic precautions should always be followed including the following:

⚠ DANGER

RISK OF ELECTROCUTION AND FIRE



HAZARD	WHAT COULD HAPPEN	HOW TO PREVENT IT
Attempting to connect generator directly to the electrical system of any building structure.	<p>Back feeding electricity through a building's electrical system to the outside utility feed lines could endanger repair persons attempting to restore service.</p> <p>Attempting to connect to the incoming utility service could result in electrocution.</p> <p>Restoration of electrical service while the generator is connected to the incoming utility could result in a fire or serious damage if a isolator switch is not installed.</p> <p>Failure to use a double throw transfer switch when connecting to a structures electrical system can damage appliances and WILL VOID the manufacturers warranty.</p>	<p>Never backfeed electricity through a structure's electrical system.</p> <p>To connect to a structure's electrical system in a safe manner, always have a Double-Throw Transfer Switch installed by a qualified electrician and in compliance with local ordinances. (When installing a Double-Throw Transfer Switch, a minimum of 10 gauge wiring must be used.)</p>

**READ AND UNDERSTAND ALL WARNINGS BEFORE
ATTEMPTING TO OPERATE GENERATOR.**

⚠ DANGER

RISK OF ELECTROCUTION AND FIRE (cont'd)



HAZARD	WHAT COULD HAPPEN	HOW TO PREVENT IT
<p>Operation of generator in rain, wet, icy, or flooded conditions.</p>	<p>Water is an excellent conductor of electricity! Water which comes in contact with electrically charged components can transmit electricity to the frame and other surfaces, resulting in electrical shock to anyone contacting them.</p>	<p>Operate generator in a clean, dry, well ventilated area. Make sure hands are dry before touching unit.</p>
<p>Use of worn damaged, undersized or ungrounded extension cords.</p>	<p>Contact with worn or damaged extension cords could result in electrocution.</p> <p>Use of undersize extension cords could result in overheating of the wires or attached items, resulting in fire.</p> <p>Use of ungrounded cordsets could prevent operation of circuit breakers and result in electrical shock.</p>	<p>Inspect extension cords before use and replace with new cord if required.</p> <p>Use proper size (wire gauge) cordset for application see chart in the Assembly section of this manual.</p> <p>Always use a cordset having a grounding wire with an appropriate grounding plug. DO NOT use an ungrounded plug.</p>
<p>Placing generator on or against highly conductive surface, such as a steel walkway or metal roof.</p>	<p>Accidental leakage of electrical current could charge conductive surfaces in contact with the generator.</p>	<p>Place generator on low conductivity surface such as a concrete slab.</p> <p>ALWAYS operate generator a minimum of six feet from any conductive surface.</p>
<p>Improper connection of items to generator.</p> <p>Operation of unit when damaged, or with guards or panels removed.</p>	<p>Exceeding the load capacity of the generator by attaching too many items, or items with very high load ratings to it could result in overheating of some items or their attachment wiring resulting in fire or electrical shock.</p> <p>Attempting to use the unit when it has been damaged, or when it is not functioning normally could result in fire or electrocution.</p> <p>Removal of guarding could expose electrically charged components and result in electrocution.</p>	<p>Read the load rating chart and instructions in the Wattage Calculation section. Make sure that the summation of electrical loads for all attachments does not exceed the load rating of the generator.</p> <p>Do not operate generator with mechanical or electrical problem. Have unit repaired by an Authorized Service Center.</p> <p>Do not operate generator with protective guarding removed.</p>

**READ AND UNDERSTAND ALL WARNINGS BEFORE
ATTEMPTING TO OPERATE GENERATOR.**

**⚠ WARNING
RISK OF FIRE**



HAZARD	WHAT COULD HAPPEN	HOW TO PREVENT IT
Attempting to fill the fuel tank while the engine is running.	Gasoline and gasoline vapors can become ignited by coming in contact with hot components such as the muffler, engine exhaust gases, or from an electrical spark.	Turn engine off and allow it to cool before adding fuel to the tank. Equip area of operation with a fire extinguisher certified to handle gasoline or fuel fires.
Sparks, fire, hot objects	Cigarettes, sparks, fires, or other hot objects can cause gasoline or gasoline vapors to ignite.	Add fuel to tank in well ventilated area. Make sure there are no sources of ignition near the generator.
Improper storage of fuel	Improperly stored fuel could lead to accidental ignition. Fuel improperly secured could get into the hands of children or other unqualified persons.	Store fuel in a OSHA approved container designed to hold gasoline. Store container in secure location to prevent use by others.
Inadequate ventilation for generator	Materials placed against or near the generator or operating the generator in areas where the temperature exceeds 104° F. ambient (such as storage rooms or garages) can interfere with its proper ventilation features causing overheating and possible ignition of the materials or buildings.	Operate generator in a clean, dry, well ventilated area a minimum of four feet from any building, object or wall. DO NOT OPERATE UNIT INDOORS OR IN ANY CONFINED AREA.
Tampering with factory set engine speed settings.	Engine speed has been factory set to provide safe operation. Tampering with the engine speed adjustment could result in overheating of attachments and could cause a fire.	Never attempt to “speed-up” the engine to obtain more performance. Both the output voltage and frequency will be thrown out of standard by this practice, endangering attachments and the user.
Overfilling the fuel tank – fuel spillage.	Spilled fuel and its vapors can become ignited from hot surfaces or sparks.	Use care in filling the tank to avoid spilling fuel. Make sure fuel cap is secured tightly and check engine for fuel leaks before starting engine. Move generator away from refueling area or any spillage before starting engine. Allow for fuel expansion. Keep maximum fuel level ¼ inch below the tip of the fuel tank. Never refuel with the engine running.

READ AND UNDERSTAND ALL WARNINGS BEFORE



⚠ DANGER

Risk of Injury and Property Damage When Transporting Generator

HAZARD	WHAT COULD HAPPEN	HOW TO PREVENT IT
Fire, Inhalation, Damage to Vehicle Surfaces	Fuel or oil can leak or spill and could result in fire or breathing hazard, serious injury or death can result. Fuel or oil leaks will damage carpet, paint or other surfaces in vehicles or trailers.	If generator is equipped with a fuel shut-off valve, turn the valve to the off position before transporting to avoid fuel leaks. If generator is not equipped with a fuel shut-off valve, drain the fuel from tank before transporting. Transport fuel only in an OSHA approved container. Always place generator on a protective mat when transporting to protect against damage to vehicle from leaks. Remove generator from vehicle immediately upon arrival at your destination

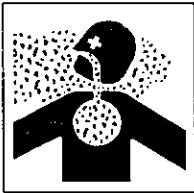

⚠ DANGER

RISK OF BREATHING - INHALATION HAZARD

HAZARD	WHAT COULD HAPPEN	HOW TO PREVENT IT
Gasoline engines produce toxic carbon monoxide exhaust fumes.	Breathing exhaust fumes will cause serious injury or death.	Operate generator in clean, dry, well ventilated area. Never operate unit in enclosed areas such as garages, basements, storage, sheds, or in any location occupied by humans or animals. Keep children, pets and others away from area of operating unit.

**READ AND UNDERSTAND ALL WARNINGS BEFORE
ATTEMPTING TO OPERATE GENERATOR.**



⚠ WARNING

RISK OF UNSAFE OPERATION

HAZARD	WHAT COULD HAPPEN	HOW TO PREVENT IT
Operation of generator in careless manner.	All sources of energy include the potential for injury. Unsafe operation or maintenance of your generator could lead to serious injury or death to you or others.	<ul style="list-style-type: none"> • Review and understand all of the operating instructions and warnings in this manual. • Become familiar with the operation and controls of the generator. Know how to shut it off quickly. • Equip area of operation with a fire extinguisher certified to handle gasoline or fuel fires. • Keep children or others away from the generator at all times.
Operation of voltage sensitive appliances without a voltage surge protector.	Any gasoline operated household generator will incur voltage variations causing damage to voltage sensitive appliances or could result in fire.	<p>Always use a U.L. listed voltage sensitive surge protector to connect voltage sensitive appliances such as TV, computer, or stereo equipment. Failure to use a U.L. listed voltage surge protector will void the warranty on your generator.</p> <p>Notice: A multiple outlet strip is not a surge protector make sure you use a U.L. listed voltage surge protector.</p>
Raising or suspending generators equipped with lift rings improperly	<p>Generator could fall causing serious injury or death to you or others.</p> <p>Improper raising or suspending can cause damage to the generator.</p>	<p>Always use proper connecting procedures as described in this manual when connecting cables, chains, or straps for raising or suspending generators equipped with lift rings.</p> <p>Always use cables, chains, or straps rated at 2000 lbs working load or more to raise or suspend generator.</p>
Operating generator while suspended	Generator will not operate properly and will cause damage to the generator and could cause serious injury or death to you or others.	Never operate generator while suspended or in an unlevel position. Always operate generator on a flat, level surface.

**READ AND UNDERSTAND ALL WARNINGS BEFORE
ATTEMPTING TO OPERATE GENERATOR.**



**⚠ WARNING
RISK OF HOT SURFACES**

HAZARD	WHAT COULD HAPPEN	HOW TO PREVENT IT
Contact with hot engine and generator components.	Contact with hot surfaces, such as engines exhaust components, could result in serious burns.	During operation, touch only the control surfaces of the generator. Keep children away from the generator at all times. They may not be able to recognize the hazards of this product.

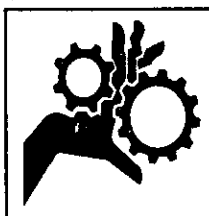

**⚠ WARNING
RISK OF MOVING PARTS**

HAZARD	WHAT COULD HAPPEN	HOW TO PREVENT IT
Contact with moving parts can result in serious injury.	The generator contains parts which rotate at high speed during operation. These parts are covered by guarding to prevent injury.	Never operate generator with guarding or cover plates removed. Avoid wearing loose fitting clothing or jewelry which could be caught by moving parts.



**⚠ WARNING
RISK FROM LIFTING**

HAZARD	WHAT COULD HAPPEN	HOW TO PREVENT IT
Lifting a very heavy object.	Serious injury can result from attempting to lift too heavy an object.	The generator is too heavy to be lifted by one person. Obtain assistance from others before you try to move it.

ASSEMBLY

CARTON CONTENTS

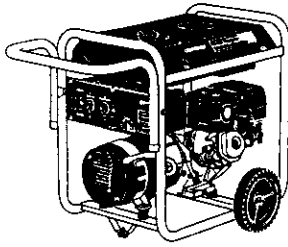

1 - Generator

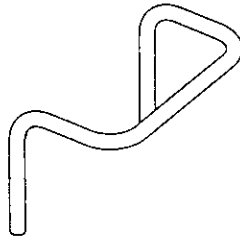

1 - Handle

1 - Parts Bag



1 - Owner's Manual



*1 - Twistlock Plug L5-20P

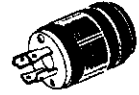

*1 - Twistlock Plug L14-20P

* **⚠ WARNING** To be installed and/or used in accordance with appropriate local electrical codes and regulations. Refer to enclosed instructions for proper installation.

1 - Parts Box

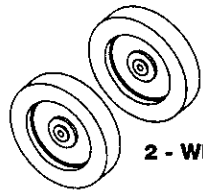

2 - Wheels

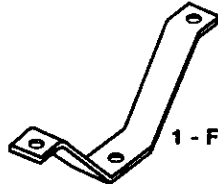

1 - Foot Bracket

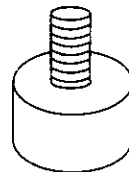

1 - Isolator Foot

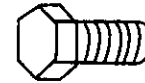

7 - 5/16-18 x 3/4 " Cap Screws (6 used)

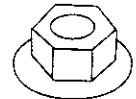

9 - 5/16-18 Lock Nuts



2 - Bracket

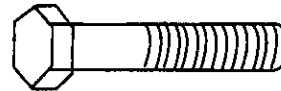

2 - 5/16-18 x 1 3/4 " Cap Screws

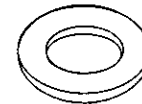

2 - Washers

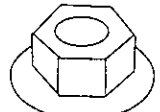

2 - 3/8-16 Lock Nuts

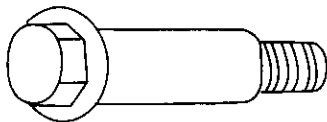

2 - Shoulder Bolts

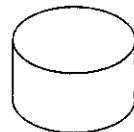

2 - Handle Caps

⚠ CAUTION

Read owner's manual. Do not attempt to operate equipment until you have read Owner's Manual for Safety, Assembly, Operation, Maintenance, Storage Instructions.

NOTE: Left and right describes the location of a part with the operator facing the outlet panel.

TOOLS NEEDED FOR ASSEMBLY

- 1- Box Cutter or Knife
- 2 - 1/2" Wrenches
- 2 - 9/16" Wrenches
- 1 - 1" thick x 1' square piece of wood

REMOVE GENERATOR FROM CARTON

- Open carton from top.
- Cut carton along dotted lines.
- Remove all carton inserts.
- Remove generator through opening in carton.

IMPORTANT: Before any attempt to start your generator be sure to check engine oil (See Adding Engine Oil paragraph in the Operation section on page 13 of this manual.)

GROUNDING THE GENERATOR

A grounding lug is supplied with the generator for use when required by local electrical ordinances. Refer to article 250 of the National Electrical Code to clarify any needed grounding information. Your local electric company or a certified electrician should be able to help you with this information.

NOTE: Your engine is already grounded to the frame by a grounding strap.

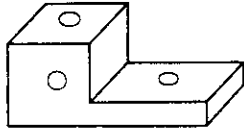

Grounding Lug

INSTALLING WHEEL KIT

The Craftsman Wheel Kit was designed to greatly improve the portability of your generator.

CAUTION Drain gas and oil before assembling the portability kit. Failure to do so will cause damage to the engine.

NOTE: Always follow state regulations for proper oil disposal.

- Place generator on level ground; drain all gas and oil from the engine (see engine manual for correct procedure).
- Place a 1" thick x 1' square piece of wood on the ground in front of the engine. With the help of another person, tilt the generator and rest the recoil starter on the wood. **NOTE:** This will support the gasoline engine during assembly and make assembly easier.
- Place a handle cap (7) onto each end of handle prior to installation.
- The handle should be installed on the electrical outlet end of the generator. Place one washer (12) on long cap screws (11). Align the handle brackets with the upper holes pre-drilled in the generator frame. Place mentioned screws through frame and handle brackets. Secure with lock nuts (8) and tighten.

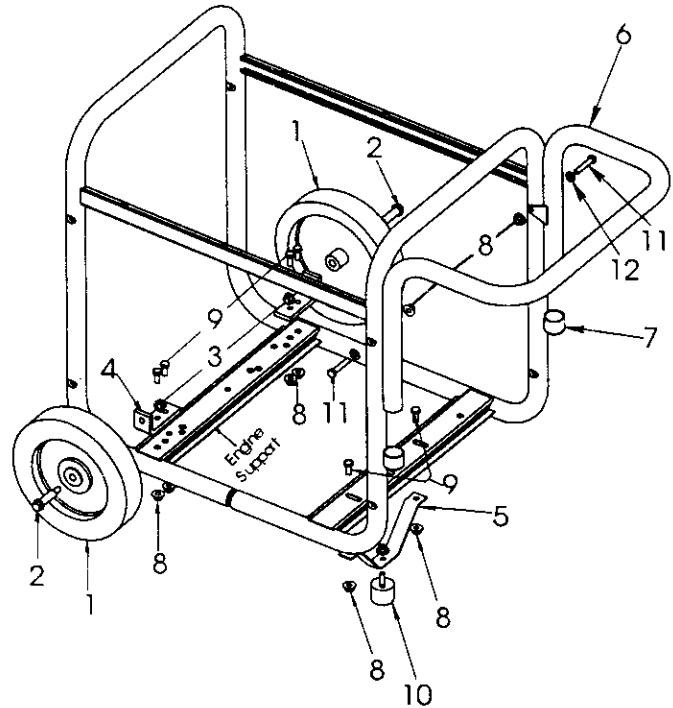

- Locate the engine support. Place one wheel bracket (4) on top of support as shown in illustration. Align with the pre-drilled holes in support. Place 2 cap screws (9) through holes in bracket and support. Secure with 2 lock nuts (8) and tighten.
- Insert one shoulder bolt (2) into wheel (1). Insert threaded end of bolt through wheel bracket, secure with lock nut (3) and tighten. **NOTE: The wheel will not rub frame if installed properly.**
- Repeat the above steps for the opposite side.
- Insert the threaded stud of rubber foot (10) through the middle hole of the foot bracket (5). Secure with lock nut (8) and tighten.
- Locate the support under the electrical outlet end of the generator. Position foot bracket (5), with rubber foot installed, under the support and align the holes in the foot bracket (5) with the slots in the support. Place one cap screw (9) through each slot in the support and the holes in the foot bracket. Secure with the lock nuts (8) and tighten.
- Once completed, the wheel kit is ready for use.

OPERATION

KNOW YOUR GENERATOR

Read this Owner's Manual and Safety Rules before operation of your Generator. Compare this illustration with your generator to familiarize yourself with the location of various controls and adjustments. Save the manual for future references.

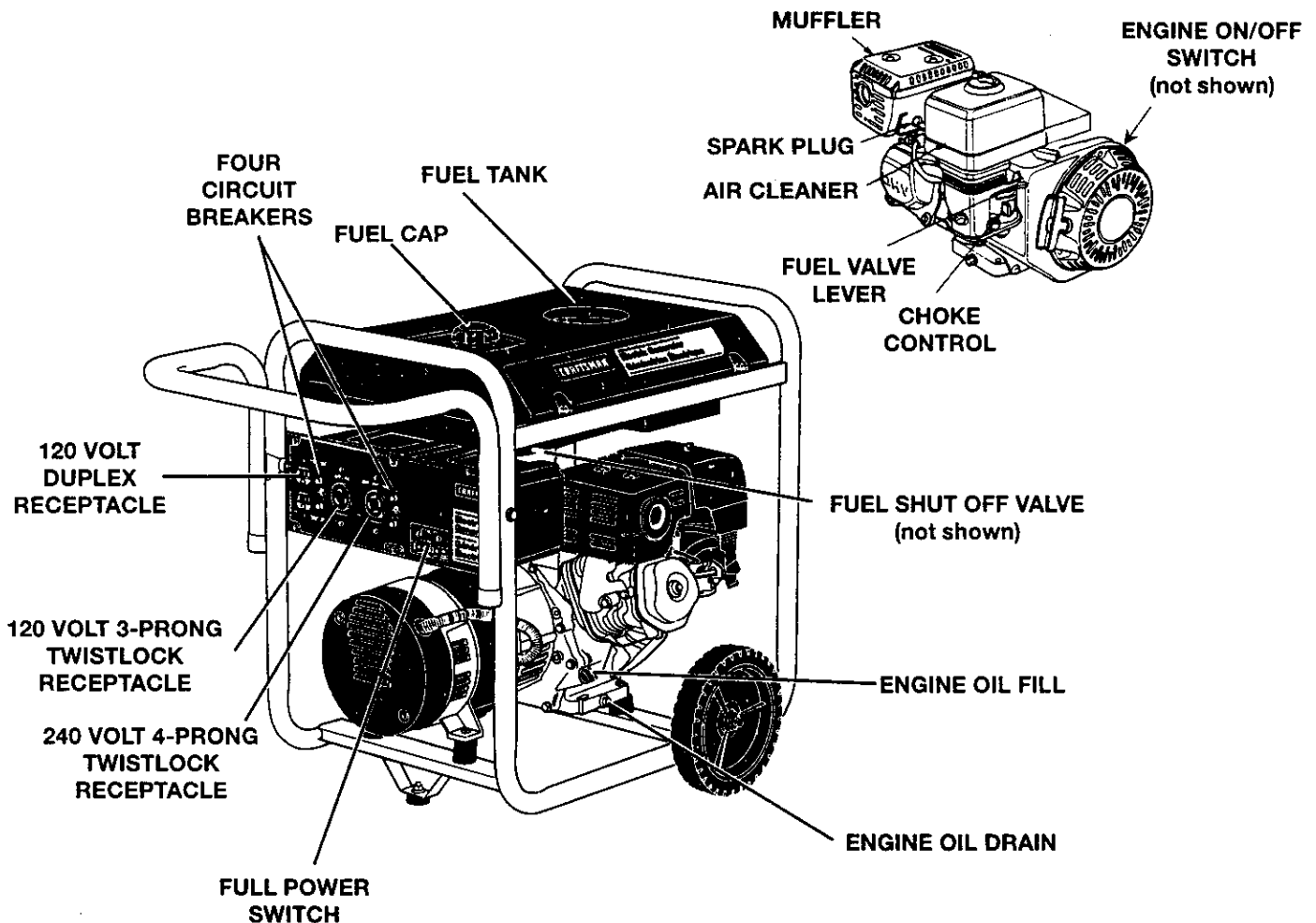

FUEL TANK- Capacity of 7 US gallons/26.5 Liters.

CHOKE CONTROL- Used to start cold engine.

ENGINE ON/OFF SWITCH- Sets engine in starting mode for recoil starter - Stops running engine.

FUEL VALVE LEVER (located on engine) - Used to shut off the flow of fuel to the engine.

FUEL SHUT OFF VALVE (located under gas tank) - Used to shut off the flow of fuel to the engine.

ENGINE OIL FILL- Check and fill engine with oil.

AIR CLEANER- Includes filter element cartridge and foam pre-cleaner that limits the amount of dirt that enters the engine.

FULL POWER SWITCH - Allows the operator to distribute power across the outlets.

CIRCUIT BREAKER- Each receptacle has a circuit breaker to protect the generator from overloading.

120 VOLT RECEPTACLES- Used to supply 4250 watts of electrical power per receptacles when the Full Power Switch is in the 120V position and 2125 watts with the Full Power Switch in the 120/240V position. Protected by 15 amp circuit breaker.

240 VOLT TWISTLOCK RECEPTACLE - Used to supply 4250 watts of electrical power per receptacles when the Full Power Switch is in the 120V position and 4250 watts with the Full Power Switch is in the 120/240V position. Protected by 15 amp circuit breaker.

RECEPTACLES

Your generator is equipped with:

- one 120 volt duplex receptacle protected by a 15 amp circuit breaker
- one 120 volt 3-prong twistlock receptacle protected by a two 15 amp circuit breakers
- one 240 volt 4-prong twistlock receptacle protected by two 15 amp circuit breakers

The circuit breakers are provided to protect the generator against electrical overload. If the circuit breaker trips, unplug electrical load from receptacle. Let circuit breaker cool down and then push circuit breaker button to reset.

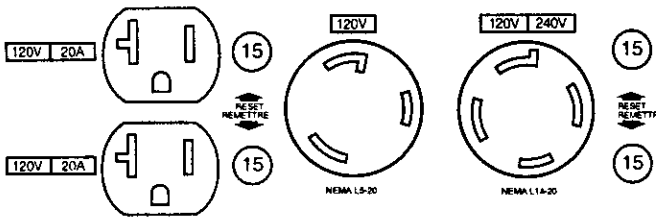

FULL POWER SWITCH

When placed in the 120V position it allows you to receive the full capacity of the generator by using all 120 volt receptacles. When in the 120/240 position, you will only be able to receive 2125 watts when using the 120 volt receptacles and the full 4250 watts when using the 240 4-prong twistlock receptacle.

Full Power Switch in the 120V/240V position

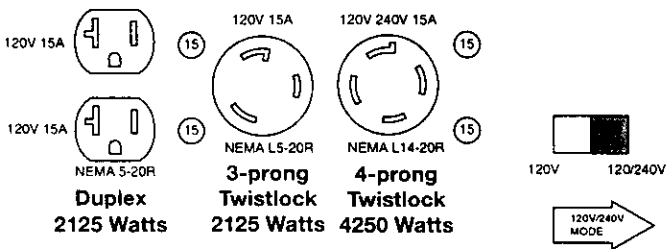

Full Power Switch in the 120V position

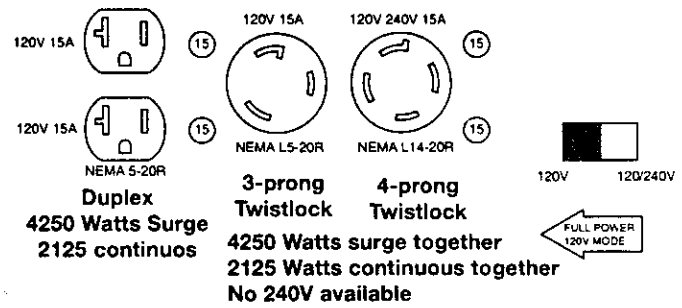

LOW OIL SHUTDOWN

Your Craftsman generator engine is equipped with Low Oil Shutdown. Low Oil Shutdown is a safety device designed to protect your engine from damage in the event the oil level in the crankcase is low.

If while the engine is running, the oil gets low, it will automatically shut itself down and will not restart until the oil is added. If the oil is low before start-up, the generator will not start until oil is added.

NOTE: The Low Oil Shutdown mechanism is very sensitive. You must fill the engine to the full mark on the dipstick to inactivate this safety device.

GENERATOR CAPACITY

Exceeding the rated capacity of your generator can result in serious damage to your generator and connected electrical devices. You should observe the following to prevent overloading the unit:

- Starting and running wattage requirements should always be calculated when matching a generator's wattage capacity to the appliance or tool.
- There are two types of electrical appliances that can be powered by your generator:
 - A. Items such as radios, light bulbs, television sets, and microwaves have a "resistive load". Starting wattage and running wattage are the same.
 - B. Items such as refrigerators, air compressors, washer, dryer, and hand tools that use an electrical motor have an "inductive load". Inductive load appliances and tools require approximately 2 to 4 times the listed wattage for **starting** the equipment. This initial load only lasts for a few seconds on start-up but is very important when figuring your total wattage to be used.

NOTE: Some inductive appliances and tools will list on the motor name plate, the starting and running voltage and amperage requirements. Use the following formula to convert voltage and amperage to wattage: **(Volts X Amp = Watts)**

- Always start your largest electric motor first, and then plug in other items, one at a time.

NOTE: On 120-volt loads the maximum starting wattage should **NOT** exceed one half of the rated generator wattage. Example: a 4250 rated wattage generator = 2125 maximum starting wattage.

The guide is provided to assist you in determining the appliances and tools that can be ran with the wattage capacity of your generator.

OBTAINING ELECTRICITY FROM GENERATOR

There are basically two ways to obtain electricity from a generator:

- Use of extension cords directly from the generator to the appliance, lights, tools, etc.
- Use of a double-throw transfer switch installed directly to the main electrical supply outside of the house.

Extension Cord

When using an appliance or tool at a considerable distance from the generator, a 3-wire extension cord that has a 3-blade grounding plug and a 3-slot receptacle that accepts the tool's plug **MUST** be used in order to reduce the risk of electrical shock. A cord of adequate size must be used. A minimum of 12 gauge wire size with at least a 20 amp draw can be used. When amperage exceeds 20 amps a 10 gauge wire size should be used.

⚠ WARNING An extension cord that is hot to the touch is overloaded. Repair or replace damaged extension cords immediately.

Connecting Generator To Main Electrical Supply

Potential hazards exist when a electrical generator is connected to the main electrical supply coming into the house. It is at that point that the generator could feed back into the utility company's system causing possible electrocution of workers who are repairing electrical lines. To avoid back feeding of electricity into utility systems, a **double-throw transfer switch** should be installed between the generator and utility power. This device should be installed by a licensed electrician and in compliance with all local electrical codes.

NOTE: When installing a Double-Throw Transfer Switch, a minimum of 10 gauge wiring must be used.

BEFORE STARTING ENGINE

⚠ CAUTION Always check engine oil level before every start. Running engine low of oil or out of oil could result in serious damage to the engine.

Adding Engine Oil

Your generator has been shipped without oil in the engine.

To add oil:

- Remove the filler cap/dipstick.
- Fill to the edge of the oil filler hole. Oil capacity is 37.1 ounces/1.1 liters.
- Replace filler cap/dipstick and tighten securely.

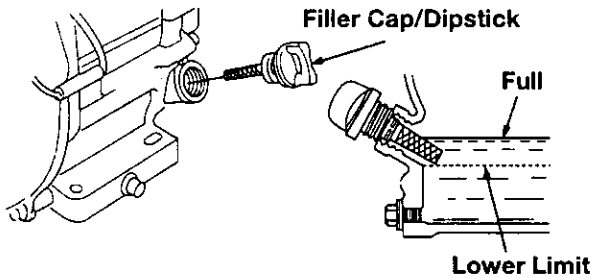

SAE 10W-30 (4 stroke automotive detergent oil) is recommended for general use. Other viscosities shown in the chart may be used when the average temperature in your area is within the recommended range.

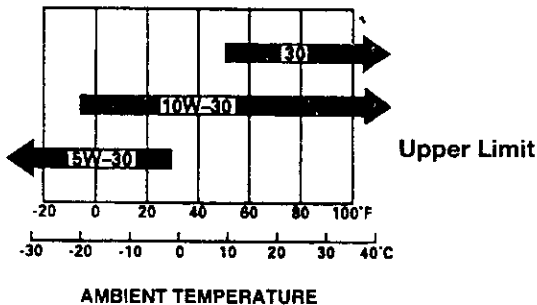

The SAE oil viscosity and service classifications are in the API label on the oil container. API SERVICE category SF or SG oil is recommended.

Gasoline

- Remove gas cap.
- Add unleaded gasoline with a pump octane rating of 86 or higher, slowly, to fuel tank. Do not mix oil with gasoline.

⚠ CAUTION Never fill fuel tank completely. Fill tank to 1/2" below the bottom of the filler neck to provide space for fuel expansion. Wipe any fuel spillage from engine and equipment before starting engine.

- Do not overfill.

⚠ WARNING Never fill fuel tank indoors. Never fill fuel tank when engine is running or hot. Do not smoke when filling fuel tank.

To Start Your Generator

⚠ CAUTION Never run engine indoors or in enclosed, poor ventilated areas. Engine exhaust contains carbon monoxide, an odorless and deadly gas.

- Open the fuel shut-off valve located under the gas tank. Turn counter clockwise until the valve stops.

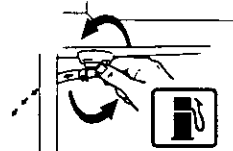

- Move fuel valve lever to ON position.

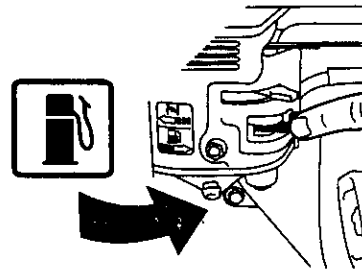

- Move choke control lever to CLOSED position.

NOTE: To restart a warm engine, move choke control to OPEN position.

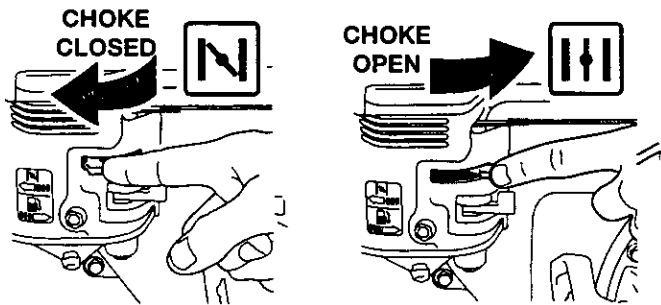

- Turn engine switch to ON position.

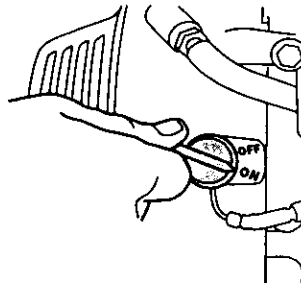

⚠ CAUTION You **MUST** unplug any load from the generator before starting to prevent permanent damage to any appliances.

- Pull starter grip slowly until you feel resistance, then pull briskly. Return starter grip gently. Pull rope with a rapid full arm stroke. Let rope rewind slowly. Repeat if necessary.

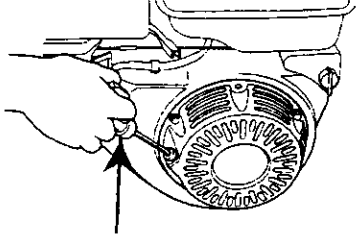

Starter Grip

NOTE: IF ENGINE OIL LEVEL IS TOO LOW, ENGINE WILL NOT START. CHECK OIL LEVEL AND ADD IF NECESSARY.

- If choke control lever is in CLOSED position, move lever to OPEN position as engine warms up.

IMPORTANT: Allow generator to run at no load for 5 minutes upon each initial start-up to allow engine and generator to stabilize.

STOPPING ENGINE

- Disconnect all electrical loads.
- Turn engine switch to "OFF" position.

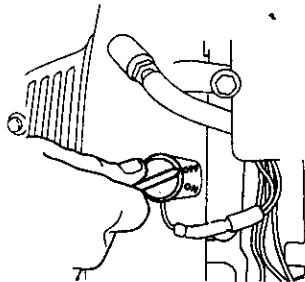

- Move the fuel valve lever to the "OFF" position.

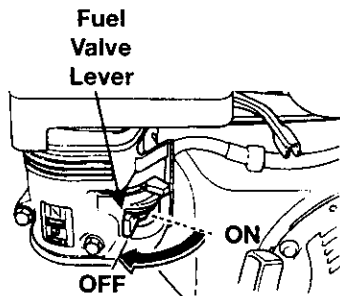

- Close fuel shut-off valve located under gas tank.

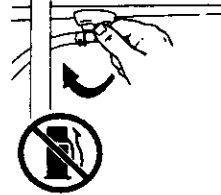

IMPORTANT: Never store engine with fuel in tank, indoors, or in enclosed, poorly ventilated areas or where fuel fumes may reach an open flame.

CONNECTING ELECTRICAL LOADS

- Let engine run and warm up for five minutes after starting with no electrical load.

Connect loads in the following manner to prevent damage to equipment:

- Connect inductive load equipment first, inductive loads consist of refrigerators, freezers, water pumps, air conditioners, or small hand tools. Connect the items that require the most wattage first.
- Connect the lights next.
- Voltage sensitive equipment should be the last equipment connected to the generator. Plug voltage sensitive appliances such as TV's, VCR's, microwaves, ovens, computers, and cordless telephones into a UL listed voltage surge protector, then connect the UL listed voltage surge protector to the generator.

IMPORTANT: You should always add up the rated watts of all lights, tools and appliances you are powering at one time. This total should not exceed the rated capacity of you generator or circuit breaker rating of the receptacle supplying power.

MAINTENANCE

CUSTOMER RESPONSIBILITIES TABLE					
Perform task at every indicated month or operating hour interval, whichever comes first.	Before each use	First month or every 20 Hrs.	Every 3 months or 50 Hrs.	Every 6 months or 100 Hrs.	Every year or 300 Hrs.
MAINTENANCE TASK					
Engine Oil	Check	X			
	Change		X	X	
Air Filter	Check	X			
	Clean		X (1)		
	Replace				X *
Sediment cup	Clean			X	
Check Spark Plug	Clean-Readjust			X	
	Replace				X
Spark arrester (optional part)	Clean			X (2)	
Fuel line	Check	Every 2 years (Replace if necessary) (2)			
Prepare Unit for Storage		Prepare unit for storage if it is to remain idle for more than 30 days.			

- 1 Service more frequently when used in dusty areas.
 - 2 These items should be service by your authorized service dealer.
- * Replace the paper air filter element only.

GENERAL RECOMMENDATIONS

The warranty of the generator does not cover items that have been subjected to operator abuse or negligence. To receive full value from the warranty, operator must maintain the generator as instructed in this manual.

Some adjustments will need to be made periodically to maintain your generator.

GENERATOR MAINTENANCE

Your generator should be kept clean and dry at all times. The generator should not be stored or operated in environments that include excessive moisture, dust or any corrosive vapors. If these substances are on the generator, clean with a cloth or soft bristle brush. Do not use a garden hose or anything with water pressure to clean the generator. Water may

enter the cooling air slots and could possibly damage the rotor, stator and the internal windings of the generator head.

All adjustments in the Maintenance section of this manual should be made at least once each season.

ENGINE MAINTENANCE

⚠ WARNING Improperly maintaining this engine, or failure to correct a problem before operation, can cause a malfunction in which you can be seriously hurt or killed.

Always follow the inspection and maintenance recommendations and schedules in this owner's manual.

Oil

- Oil level should be checked prior to each use and at least every 5 hours of operation.

To check oil:

- Remove the filler cap/dipstick and wipe it clean.
- Insert and remove the dipstick without screwing it into the filler neck. Check the oil level shown on the dipstick.
- If the oil level is low, fill to the edge of the oil filler hole with the recommended oil. See the **Adding Oil** paragraph on page 14 of this manual.
- Screw in the filler cap/dipstick securely.

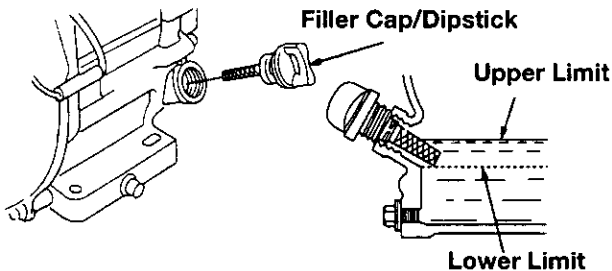

Changing Engine Oil

For a new engine, change oil after the first **20 operating hours**. Thereafter, change oil after every **100 hours** of operation.

Change the oil while the engine is still warm. The oil will flow freely and carry away more impurities. Make sure the engine is level when filling, checking or changing oil.

Change the oil as follows:

- To keep dirt, grass clippings, etc. out of the engine, clean the area around the drain plug and dipstick before removing it.
- Place a suitable container below the engine to catch the used oil, then remove the filler cap/dipstick and the drain plug.

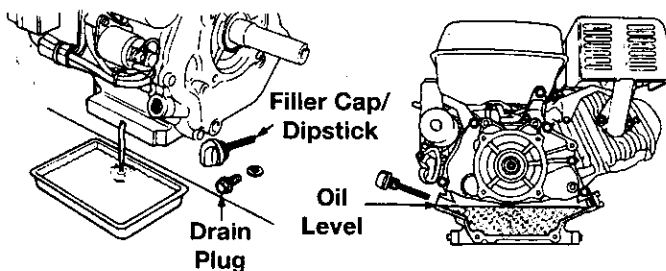

- Allow the used oil to drain completely, then reinstall the drain plug, and tighten it securely.
- Please dispose of used motor oil in a manner that is compatible with the environment. We suggest you take used oil in a sealed container to your local recycling center or service station for reclamation. Do not throw it in the trash, pour it on the ground, or down a drain.
- With the engine in a level position, fill to the outer

edge of the oil filler hole with the recommended oil. See the **Adding Oil** paragraph on page 14 of this manual.

Air Filter

A dirty air filter will restrict air flow to the carburetor, reducing engine performance. If you operate the engine in very dusty areas, clean the air filter more often than specified in the Owner's Responsibilities

- Remove the wing nut from the air cleaner cover, and remove the cover.

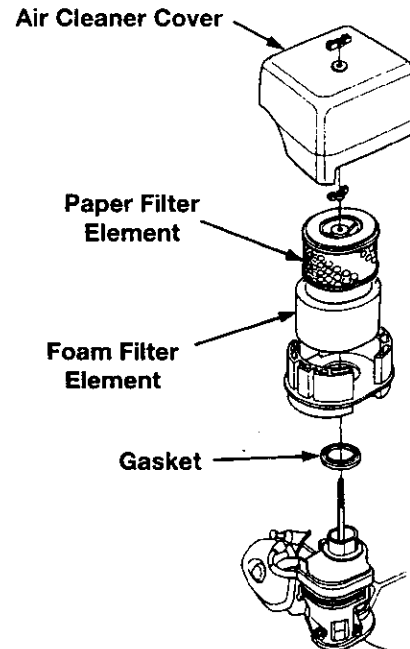

- Remove the wing nut from the air filter and remove the filter.
- Remove the foam filter from the paper filter.
- Inspect both air filter elements and replace them if they are damaged. Always replace the paper air filter element at the scheduled interval. See **Customer's Responsibilities** on page 16 of this manual
- Clean the air filter elements if they are to be reused.

To clean the paper element:

- Tap the filter element several times on a hard surface to remove dirt, or blow compressed air (not exceeding 30 psi, 207kPa, 2.1kg/cm²) through the filter element from the inside. Never try to brush off dirt; brushing with force dirt into the fibers.

To clean the foam air filter element:

- Clean in warm in warm soapy water, rinse, and allow to dry thoroughly. Or clean in nonflammable solvent and allow to dry. Dip the filter element in clean engine oil, then squeeze out all excess oil. The engine will smoke when started if too much oil is left in the foam.

- Wipe dirt from the inside of the air cleaner base and cover, using a moist rag. Be careful to prevent dirt from entering the air duct that leads to the carburetor.
- Place the foam air filter element over the paper element, and reinstall the assembled air filter. Be sure the gasket is in place beneath the air filter. Tighten the air filter wing nut securely.
- Install the air cleaner cover, and tighten the cover wing nut securely.

Sediment Cup Cleaning

- Move the fuel valve lever to the "OFF" position, then remove the fuel sediment cup and O-Ring.

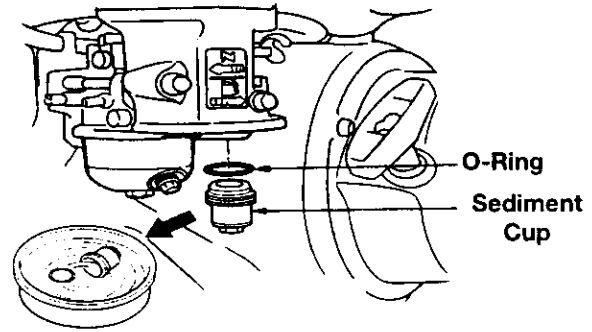
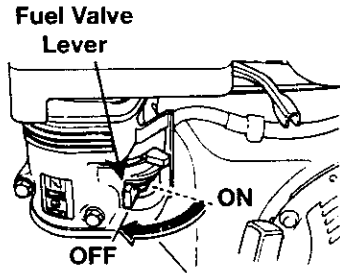

- Wash the sediment cup and O-Ring in nonflammable solvent, and dry them thoroughly.
- Place the O-ring in the fuel valve, and install the sediment cup. Tighten the sediment cup securely.
- Move the fuel valve to the "ON" position and check for leaks. Replace the O-ring if there is any leakage.

Clean and Replace Spark Plug

Check spark plug yearly or every 100 operating hours.

- Clean area around spark plug.
- Remove and inspect spark plug.
- Replace spark plug if electrodes are pitted, burned or porcelain is cracked.
- Check electrode gap with wire feeler gauge and set gap .030 if necessary.
- Install spark, tighten securely.

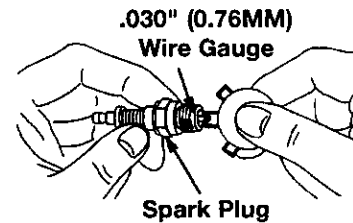

⚠ WARNING Gasoline is highly flammable and explosive. You can be burned or seriously injured when handling fuel.

- Keep heat, sparks, and flame away.
- Handle fuel only outdoors.
- Wipe up spills immediately.

SERVICE ADJUSTMENTS

CARBURETOR

The carburetor of your generator is pre-set at the factory. The carburetor should not be tampered with. If your generator is used at an altitude in excess of 4000 feet performance may be affected. If so consult with your nearest Sears Service Center regarding high altitude set changes.

GOVERNOR

Your engine governor maintains the constant operating speed of your generator. **DO NOT** tamper with the engine governor which is factory set for proper engine speed.

Over-speeding your engine above factory high speed setting can be dangerous and could possibly cause personal injury or property damage. If you believe the engine is running too fast or slow, take your generator to a Authorized Sears Service Center for repair and adjustment.

⚠ CAUTION Low engine speeds impose a heavy load on the engine and when sufficient power is not available the engine life could be shortened.

STORAGE

If you are going to store your generator for more than 30 days, use the following information as a guide to prepare the generator for storage.

CAUTION Never store generator with fuel in the tank indoors or in enclosed, poorly ventilated areas, where fumes can reach an open flame, spark or pilot light as on a furnace, water heater, clothes dryer or other gas appliances.

Engine Preparation

- Add fuel stabilizer to fuel tank to minimize the formation of fuel gum deposits during storage.
- Run engine at least 10 minutes after adding stabilizer to allow it to enter the fuel system.

- Disconnect the spark plug wire and remove the spark plug.
- Add one teaspoon of oil through the spark plug hole.
- Place rag over spark plug hole and pull the recoil a few times to lubricate the combustion chamber. Replace the spark plug, but do not connect the spark plug wire.

NOTE: If a fuel stabilizer is not used, all gasoline must be drained from the tank and carburetor to prevent gum deposits from forming on these parts and causing possible malfunction of the engine.

Generator

- Clean the generator as outlined in the Generator Maintenance paragraph on page 16 .
- Check that cooling air slots and openings on generator are open and unobstructed.

TROUBLESHOOTING GUIDE

PROBLEM	CAUSE	CORRECTION
Engine will not start	<ol style="list-style-type: none"> 1. Low on fuel or oil. 2. Ignition switch in "Off" position. 3. Faulty spark plug. 4. Choke in wrong position. 5. Fuel shut-off valve in closed position. 6. Unit loaded during start-up. 7. Spark plug wire loose. 	<ol style="list-style-type: none"> 1. Add fuel or oil. 2. Turn to "ON" position 3. Replace spark plug. 4. Adjust choke accordingly. 5. Open fuel shut-off valve. 6. Remove load from unit. 7. Attach wire to spark plug.
No electrical output	<ol style="list-style-type: none"> 1. Faulty receptacle. 2. Circuit breaker kicked out. 3. Defective capacitor. 4. Faulty power cord. 	<ol style="list-style-type: none"> 1. Have Authorized Sears Service Center replace. 2. Depress and reset. 3. Have Authorized Sears Service Center replace capacitor. 4. Repair or replace cord.
Repeated circuit breaker tripping	<ol style="list-style-type: none"> 1. Overload 2. Faulty cords or equipment. 	<ol style="list-style-type: none"> 1. Reduce load. 2. Check for damaged, bare, or frayed wires on equipment. Replace.
Generator overheating the circuit breaker depressed	<ol style="list-style-type: none"> 1. Generator overloaded. 2. Insufficient ventilation. 	<ol style="list-style-type: none"> 1. Reduce load. 2. Move to adequate supply of fresh air.

GENERATOR PARTS

CRAFTSMAN 4250 GENERATOR 919.670040

GENERATOR ASSEMBLY

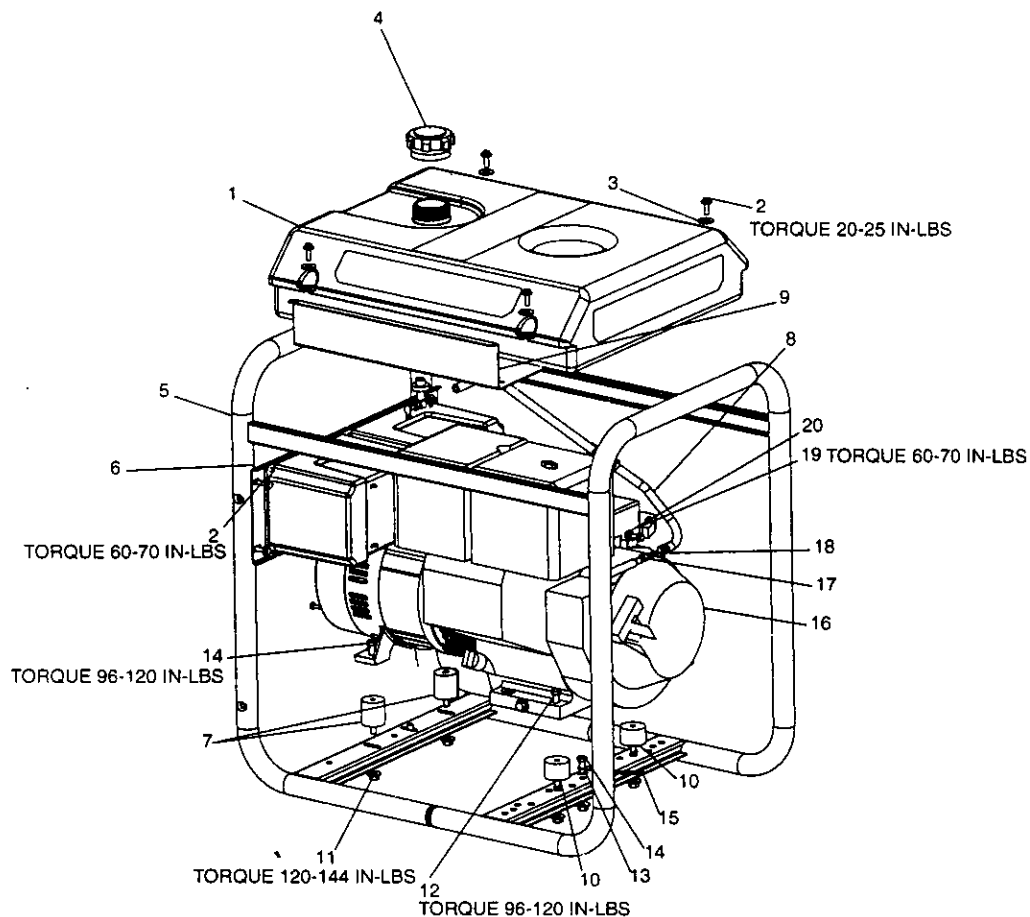

**KEY
NO.**

DESCRIPTION

PART NUMBER

1	FUEL TANK	GS-0795
2	FUEL TANK SCREWS	91895680
3	WASHER	SSN-632
4	FUEL CAP	GS-0443
5	FRAME ASSEMBLY	GS-0909
6	PANEL ASSEMBLY	GS-0844
7	ISOLATOR	GS-0433
8	FUEL HOSE	GS-0225
9	HEAT SHIELD	GS-0675
10	ISOLATOR	GS-0033
11	LOCK NUT 5/16-18	SSF-8150
12	SCREW 5/16-18 x 1	SSF-605
13	LOCK WASHER	SSN-1619-ZN
14	SCREW 5/16-18 x 3/4	SS-12-CD
15	GROUND STRAP	GS-0118
16	ENGINE (model # GX270VWN2)	*
17	HOSE CLAMP .301 ID	GS-0560
18	UNION REDUCER 1/4 TO 3/8	GS-0535
19	SCREW 1/4 x 5/8	39124607
20	LOCK WASHER	SS-1503-CD

* SEE ENGINE PAGES 27-36

GENERATOR PARTS

CRAFTSMAN 4250 GENERATOR 919.670040

GENERATOR ASSEMBLY

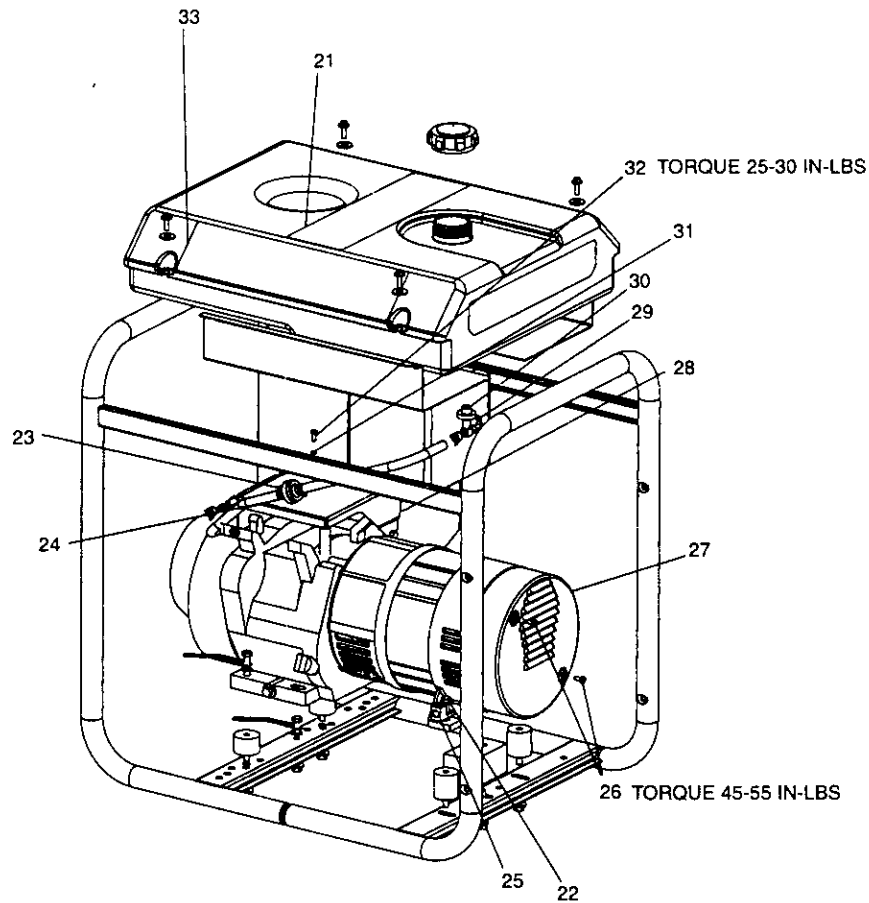

KEY

<u>NO.</u>	<u>DESCRIPTION</u>	<u>PART NUMBER</u>
21	LABEL, OPERATION	LA-3048-1
22	SCREW, HEX WASHER	SSF-928
23	FUEL CLAMP .50 ID	GS-0227
24	FUEL FILTER	GS-0459
25	GROUND LUG	GS-0117
26	SCREW 10-24 x 9/16	SSF-553-1
27	END COVER	GS-0077
28	ENGINE COVER	GS-0540
29	FUEL SHUT OFF VALVE	GS-0437
30	DRAINCOCK GROMMET	GS-0446
31	LOCK WASHER #10	SSN-626
32	SCREW M5 x 12HHCS	SSF-627
33	LABEL, WARNING	LA-2911

GENERATOR PARTS

CRAFTSMAN 4250 GENERATOR 919.670040

GENERATOR HEAD ASSEMBLY

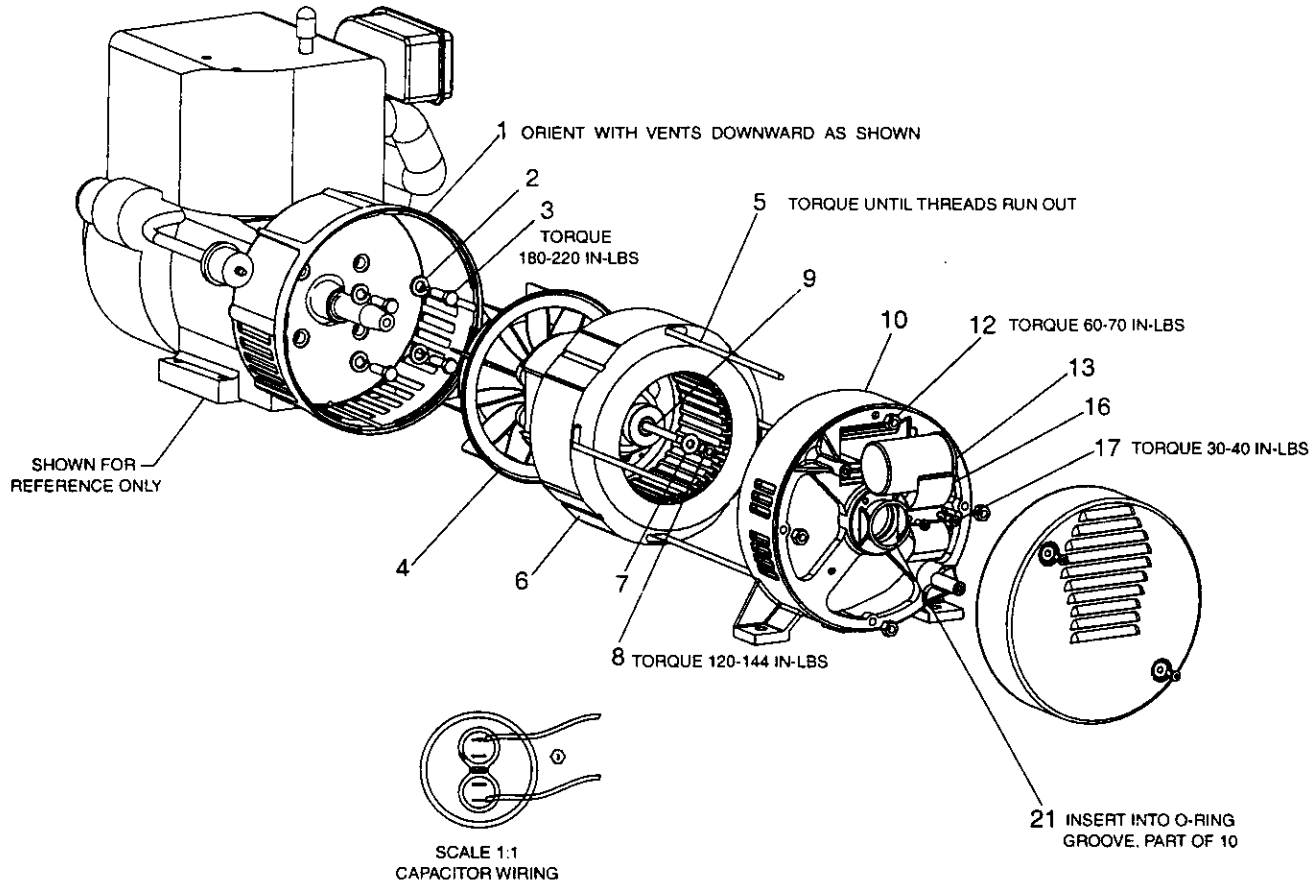

**KEY
NO.**

DESCRIPTION

PART NUMBER

1	DRIVE END ADAPTER	GS-0076
2	LOCK WASHER 3/8	SSN-619
3	CAP SCREW 3/8-16 x 1	SSF-577
4	ROTOR ASSEMBLY	GS-0883
5	STATOR THRU BOLT	GS-0110
6	STATOR ASSEMBLY	GS-0884
7	WASHER 11/16OD x 11/32	SS-6506-CD
8	NUT 5/16-24	SSF-576
9	ROTOR THRU BOLT	GS-0091-1
10	BEARING SUPPORT	GS-0861
12	HEX NUT 1/4-20	SSF-575
13	CAPACITOR	GS-0873
16	CAPACITOR BRACKET	GS-0595
17	SCREW 10-24	SSF-553-1
21	O-RING	GS-0862

GENERATOR PARTS

CRAFTSMAN 4250 GENERATOR 919.670040

PANEL ASSEMBLY

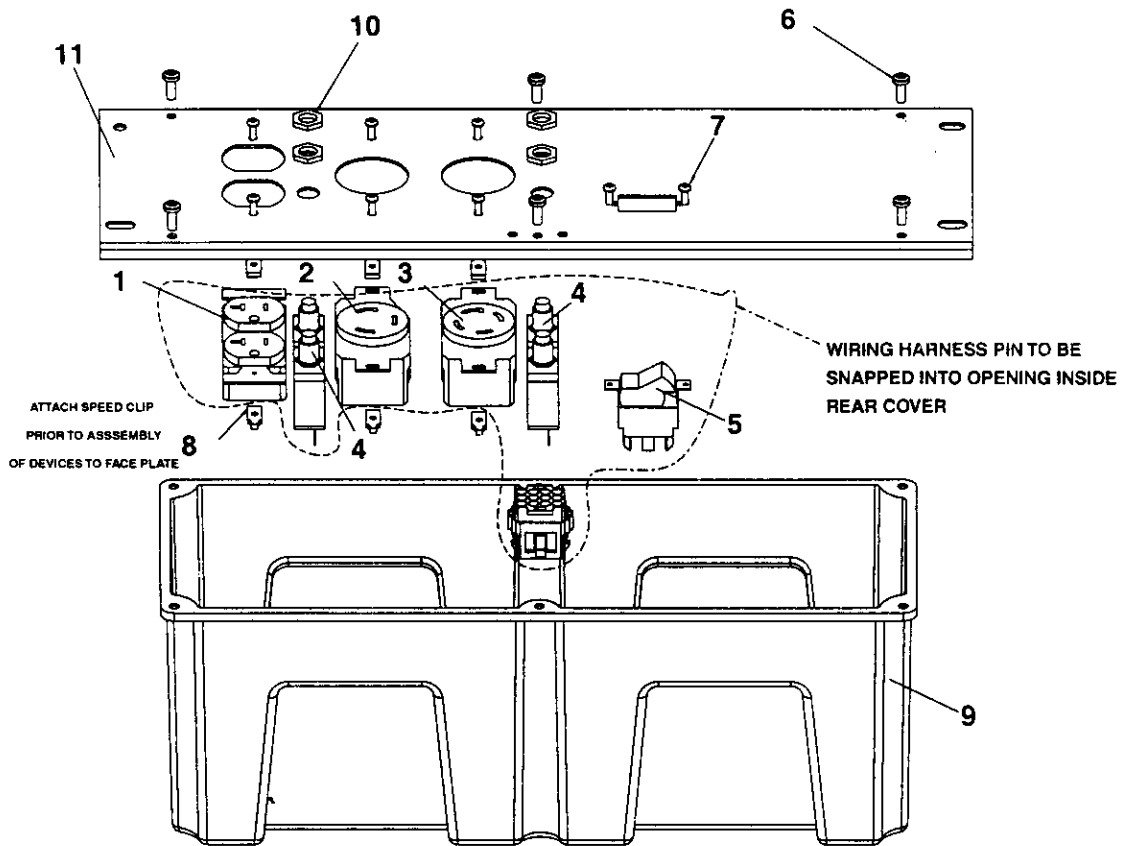

**KEY
NO.**

KEY NO.	DESCRIPTION	PART NUMBER
1	RECEPTACLE, DUPLEX	GS-0804
2	3 PRONG TWISTLOCK	GS-0480
3	4 PRONG TWISTLOCK	GS-0445
4	CIRCUIT BREAKER	GS-0024
5	FULL POWER SWITCH	GS-0045
6	SCREW, 10-9 X .50 PLASTITE	SSF-3156
7	SCREW, #6-32 X .50 TORX	SSF-583
8	SPEED NUT, #6-32	SSF-584
9	COVER, PANEL	GS-0017-1
10	HEX JAM NUT 7/16	SSF-595
11	LABEL, PANEL	LA-3388

GENERATOR PARTS

CRAFTSMAN 4250 GENERATOR 919.670040

WHEEL KIT

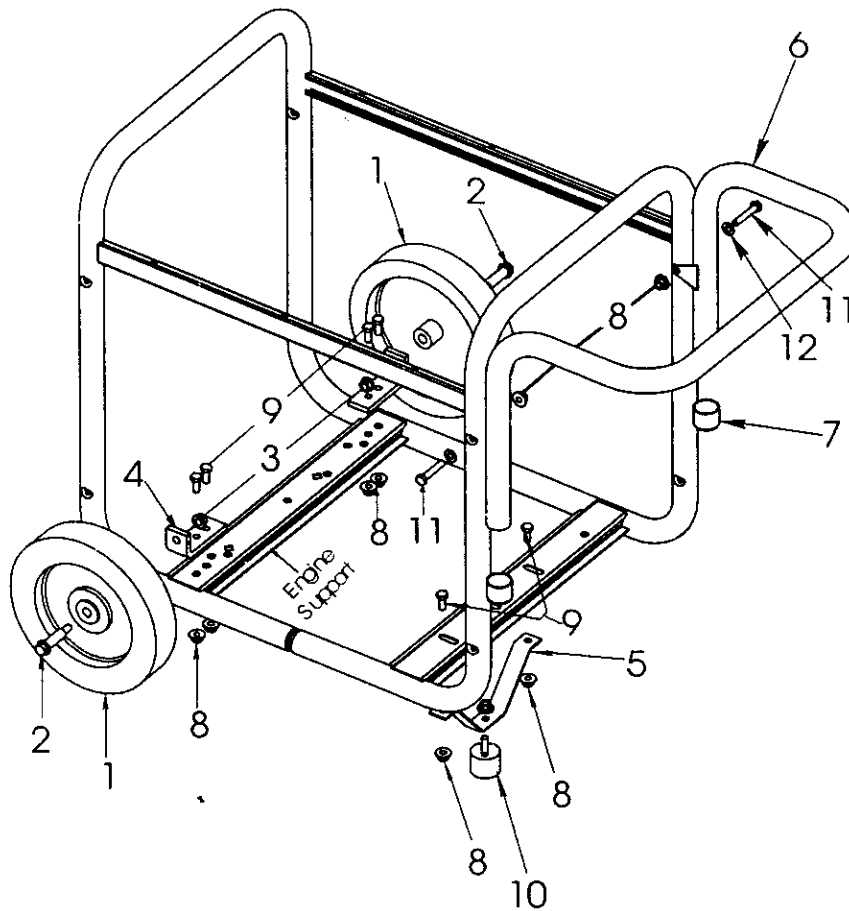

Key No.	Description	PART NO.
1	Wheel (2 used)	AC-0014
2	Shoulder Bolt (2 used)	CAC-60
3	Lock Nut 3/8"-16 (2 used)	SSF-8111-ZN
4	Wheel Bracket (2 used)	GS-0561
5	Foot Bracket	GS-0562
6	Handle	GS-0564
7	Handle Cap (2 used)	GS-0565
8	Lock Nut 5/16"-18 (9 used)	SSF-8150
9	Cap Screw 5/16"-18 x 3/4" (6 used)	SS-12-CD
10	Isolator Foot	GS-0587
11	Cap Screw 5/16-18 x 1.75" (2 used)	SSF-999-1
12	Washer (2 used)	SS-6506-CD

GENERATOR PARTS

CRAFTSMAN 4250 GENERATOR 919.670040

WIRING DIAGRAM

CONTROL PANEL
REAR VIEW

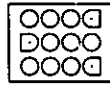

REAR VIEW
HOUSING (MALE)

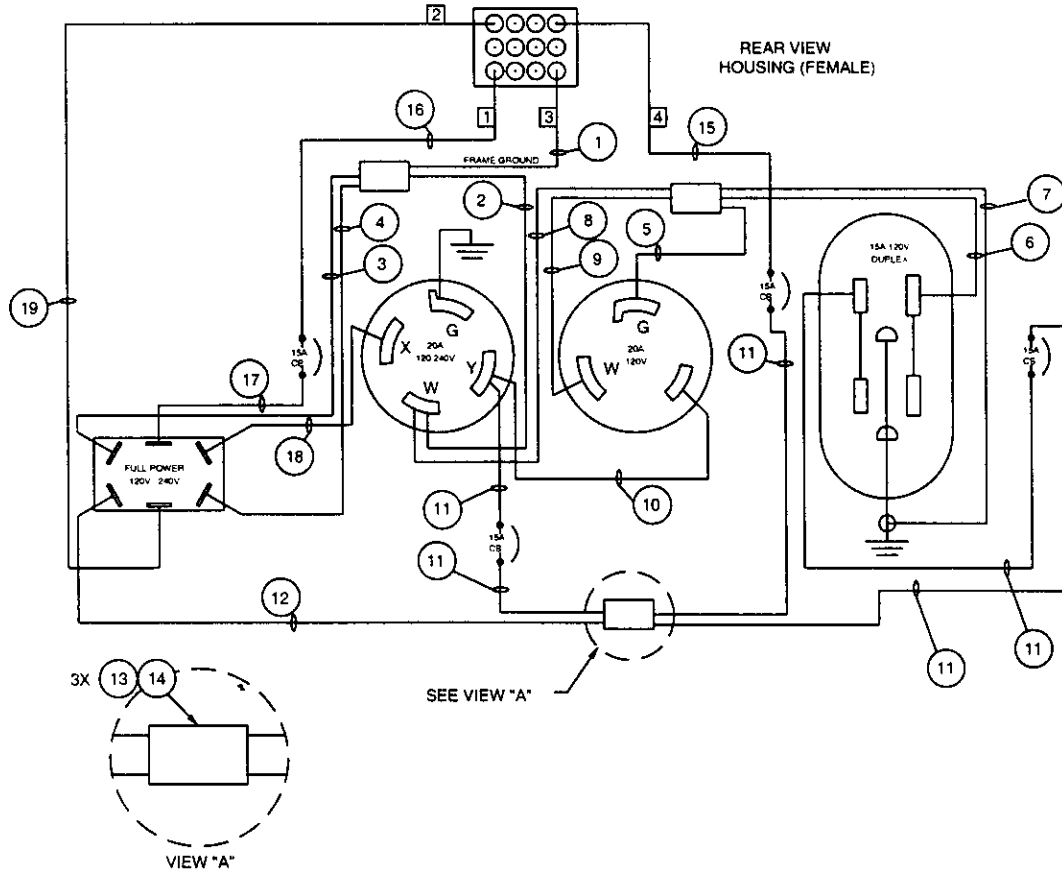

KEY

NO.	DESCRIPTION	COLOR
1	WIRE #12 AWG	GREEN
2	WIRE #12 AWG	GREEN
3	WIRE #12 AWG	GREEN
4	WIRE #12 AWG	GREEN
5	WIRE #12 AWG	GREEN
6	WIRE #12 AWG	GREEN
7	WIRE #12 AWG	GREEN
8	WIRE #12 AWG	GREEN
9	WIRE #12 AWG	GREEN
10	WIRE #12 AWG	RED
11	WIRE #12 AWG	RED
12	WIRE #12 AWG	RED
13	TUBE HEAT SHRINK 1.5 IN	NA
14	SPLICE TERMINAL	NA
15	WIRE #12 AWG	RED
16	WIRE #12 AWG	BLACK
17	WIRE #12 AWG	BLACK
18	WIRE #12 AWG	BLACK
19	WIRE #12 AWG	ORANGE

GENERATOR PARTS

CRAFTSMAN 4250 GENERATOR 919.670040

WIRE HARNESS

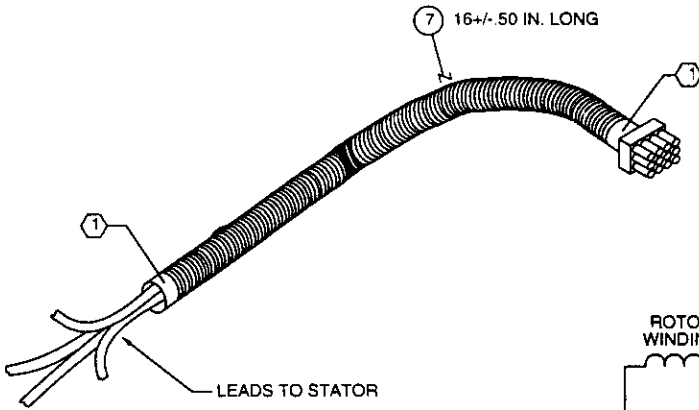

NOTE:

① TAPE CONDUIT WITH 3/4" WIDE BLACK ELECTRICAL TAPE.

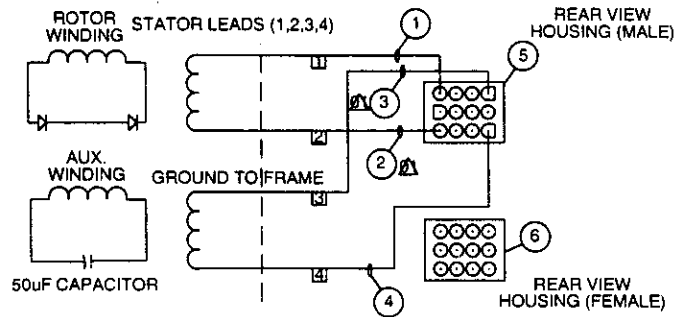

KEY

NO.	DESCRIPTION
1	WIRE PIN/MALE
2	WIRE PIN/MALE
3	WIRE PIN/MALE
4	WIRE PIN/MALE
5	PLUG FRONT
6	PLUG REAR
7	CONDUIT FLEXIBLE

ENGINE PARTS

CRAFTSMAN 4250 GENERATOR 919.670040

Honda Engine Model GX270

CYLINDER HEAD

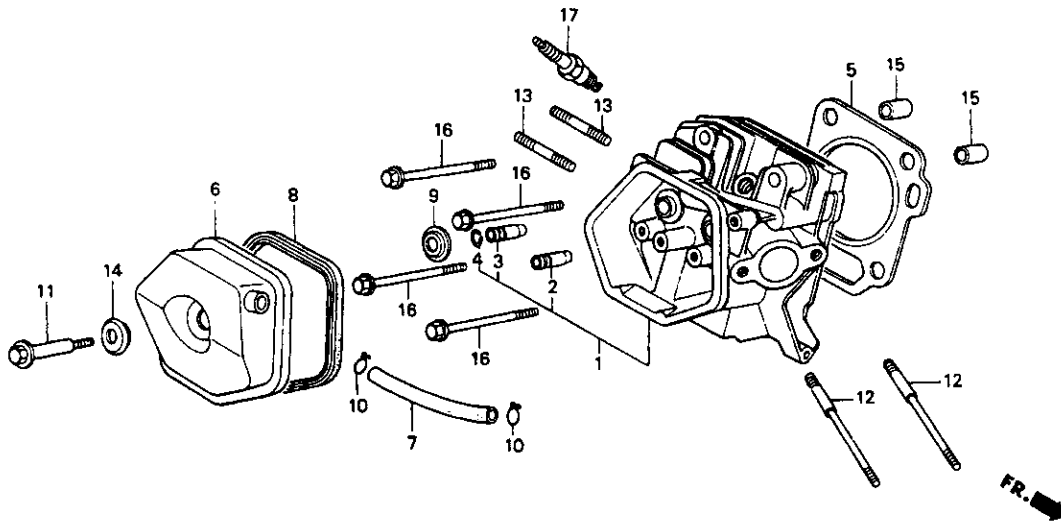

ZH98E0200

Ref	Description	Engine Serial Number From To	Qty	Part Number	H/C
1	CYLINDER HEAD COMP.	-----	1	12200-ZH9-000	4475349
2	GUIDE, VALVE (OS)	-----	(1)	12204-ZE2-306	4179164
3	GUIDE, EX.VALVE(OS)	-----	(1)	12205-ZE2-305	2089563
4	CLIP, VALVE GUIDE	-----	1	12216-ZE2-300	2089597
5	GASKET, CYLINDER HEAD	-----	1	12251-ZH9-000	3689577
6	COVER COMP., HEAD	-----	1	12310-ZE2-020	4300885
7	BULK HOSE, VACUUM (11X1000) (11X105)	-----	1	95005-11001-30M	4537312
8	GASKET, CYLINDER HEAD COVER	-----	1	12391-ZE2-020	4300893
9	SEAT, VALVE SPRING	-----	1	14775-ZE2-010	2157485
11	BOLT, HEAD COVER	-----	1	90014-ZE2-000	2027035
12	BOLT, STUD (8X123)	-----	2	90042-ZE2-000	2027043
13	BOLT, STUD (8X47)	----- 1457779	2	90047-ZE2-000	2027050
	BOLT 2, STUD (8X32)	1457780 -----	2	92900-08032-0E	2663433
14	WASHER COMP., HEAD COVER	-----	1	90441-ZE2-010	2293918
15	PIN A, DOWEL (12X20)	-----	2	94301-12200	0165324
16	BOLT, FLANGE (10X80)	-----	4	95701-10080-00	2545341
17	SPARK PLUG (BPR5ES)(NGK)	-----	(1)	98079-55846	1672443

ENGINE PARTS

CRAFTSMAN 4250 GENERATOR 919.670040

Honda Engine Model GX270

CYLINDER BARREL

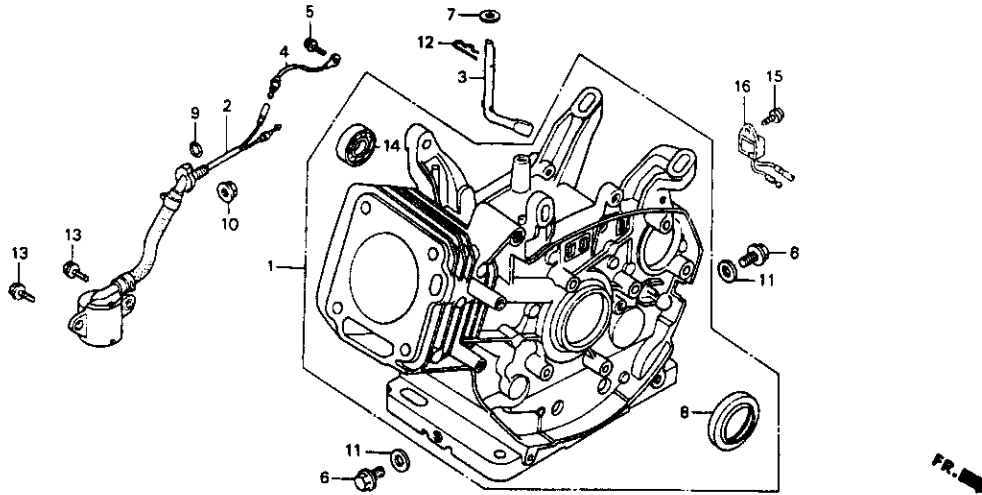

ZH98E0300ZA

Ref	Description	Engine Serial Number From To	Qty	Part Number	H/C
1	CYLINDER ASSY.(BALANCER+ALERT)	-----	1	12000-ZH9-851	4640496
2	SWITCH ASSY.,OIL LEVEL	----- 1225386	1	15510-ZE2-023	4193736
	SWITCH ASSY.,OIL LEVEL	----- 1315979	1	15510-ZE2-033	5361605
	SWITCH ASSY.,OIL LEVEL	-----	1	15510-ZE2-043	5792361
3	SHAFT, GOVERNOR ARM	-----	1	16541-ZE2-010	4723227
4	SUB-HARNESS	----- 1225386	1	32197-ZE2-003	4220406
5	BOLT, FLANGE (6X12) (CT200)	----- 1225386	1	90013-883-000	0636845
6	BOLT, DRAINPLUG	-----	2	90131-896-650	1986231
7	WASHER (8.2X17X0.8)	-----	1	90446-KE1-000	2027134
8	OIL SEAL (30X46X8)	-----	1	91201-890-003	0756494
9	O-RING (14MM) (ARAI)	-----	1	91353-671-003	0949883
10	NUT, FLANGE (10MM)	-----	1	94050-10000	0483867
11	WASHER, DRAIN PLUG (12MM)	-----	2	94109-12000	0171868
12	PIN, LOCK (8MM)	----- 1116513	1	94251-08000	0115527
	PIN, LOCK (10MM)	1116514 -----	1	94251-10000	0159269
13	BOLT, FLANGE (6X12)	-----	2	95701-06012-00	2105799
14	BEARING,RADIAL BALL (6202)	-----	1	96100-62020-00	0708941
15	BOLT, FLANGE (6X12) (CT200)	1321603 -----	1	90013-883-000	0636845
16	ALERT UNIT,OIL	1321603 -----	1	34150-ZH7-003	5858444

ENGINE PARTS

CRAFTSMAN 4250 GENERATOR 919.670040

Honda Engine Model GX270

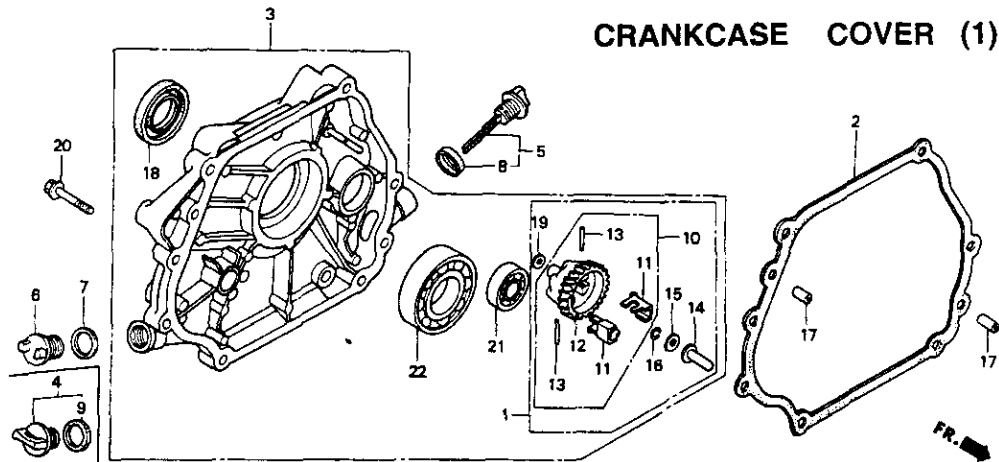

ZH98E0600A

Ref	Description	Engine Serial Number		Qty	Part Number	H/C
		From	To			
1	GOVERNOR KIT (BALANCER)	----	----	(1)	06165-ZE2-811	3689460
2	GASKET, CASE COVER	----	----	1	11381-ZE2-800	3678505
3	COVER ASSY., CRANKCASE (Q-TYPE) (BALANCER)	----	----	1	11400-ZE2-601	3689494
5	CAP ASSY., OIL	----	----	1	15600-735-003	4523106
	CAP ASSY., OIL FILLER	----	1071798	1	15600-735-700	2094886
6	CAP, OILFILLER	----	----	1	15620-ZG4-910	3678596
7	GASKET, OIL FILLER CAP	----	----	1	15621-896-010	1033042
8	GASKET, OIL FILLER CAP	----	1071798	1	15625-ZE1-000	1427079
	GASKET, OIL FILLER CAP	----	----	1	15625-ZE1-003	4497947
10	GOVERNOR ASSY. (BALANCER)	----	----	1	16510-ZE2-811	3690005
11	WEIGHT, GOVERNOR	----	----	2	16511-ZE2-000	2025955
12	HOLDER, GOVERNOR WEIGHT	----	----	1	16512-ZE2-811	3682010
13	PIN, GOVERNOR WEIGHT	----	----	2	16513-ZE2-000	2025971
14	SLIDER, GOVERNOR	----	----	1	16531-ZE2-000	2025989
15	WASHER (6X16)	----	1090816	1	90473-147-000	0465591
16	CLIP, GOVERNOR HOLDER	----	----	1	90602-ZE1-000	2456697
17	PIN, DOWEL (8X12)	----	----	2	90701-HC4-000	2978443
18	OIL SEAL (30X46X8)	----	----	1	91201-890-003	0756494
19	WASHER, PLAIN (6MM)	----	----	1	94101-06800	0345900
20	BOLT, FLANGE (8X35)	----	----	7	95701-08035-00	2724029
21	BEARING, RADIAL BALL (6202)	----	----	1	96100-62020-00	0708941
22	BEARING, RADIAL BALL (6206)	----	----	1	96100-62060-00	0636118

ENGINE PARTS

CRAFTSMAN 4250 GENERATOR 919.670040

Honda Engine Model GX270

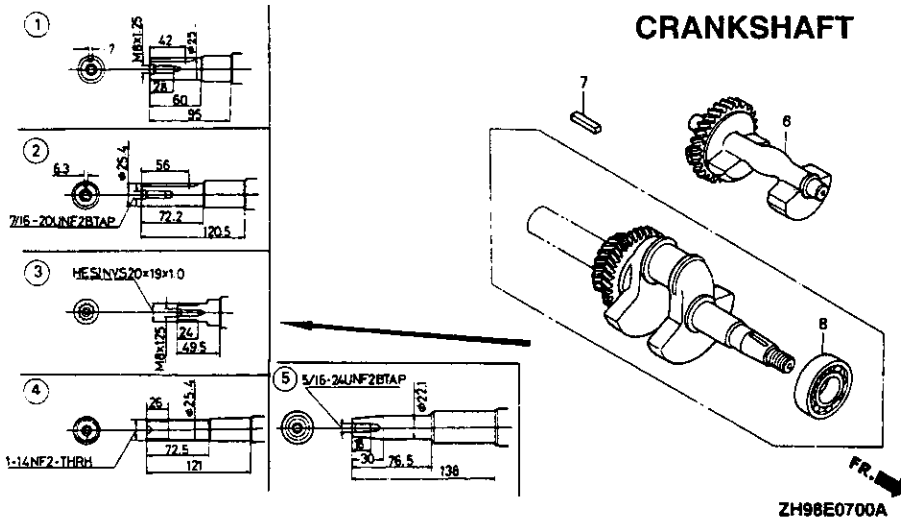

Ref	Description	Engine Serial Number From To	Qty	Part Number	H/C
5	CRANKSHAFT COMP.	-----	1	13310-ZH9-840	3689809
6	WEIGHT, BALANCER	-----	1	13351-ZE2-010	3689817
8	BEARING, RADIALBALL(6206SH)	-----	1	91001-ZH9-003	3692415

PISTON

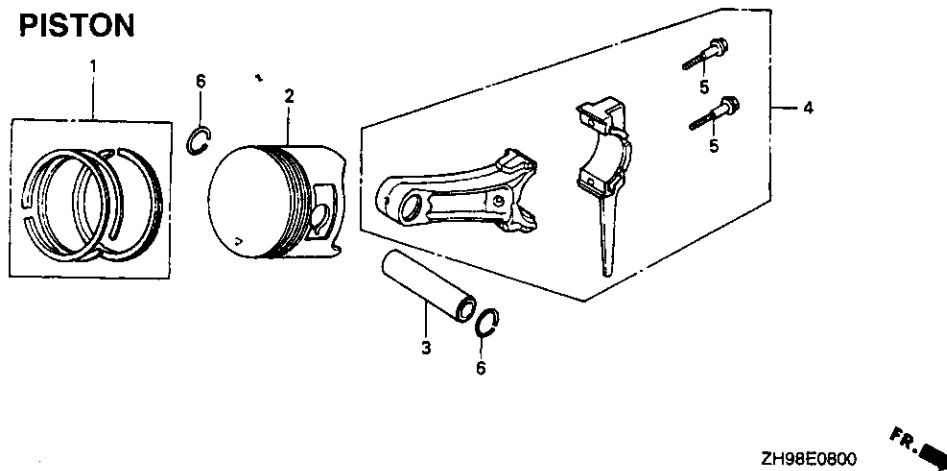

Ref	Description	Engine Serial Number From To	Qty	Part Number	H/C
1	RING SET, PISTON(STD)	-----	1	13010-ZE8-601	3689585
	RING SET, PISTON (OS0.25)	-----	(1)	13011-ZE8-601	3689619
	RING SET, PISTON (OS0.50)	-----	(1)	13012-ZE8-601	3689643
	RING SET, PISTON (0.75)	-----	(1)	13013-ZE8-601	3689676
2	PISTON (STD)	-----	1	13101-ZH9-000	3689692
	PISTON (OS0.25)	-----	(1)	13102-ZH9-000	3689718
	PISTON (OS0.50)	-----	(1)	13103-ZH9-000	3689734
	PISTON (0.75)	-----	(1)	13104-ZH9-000	3689742
3	PIN, PISTON	-----	1	13111-ZE2-000	2025484
	ROD ASSY.,CONNECTING (STD)	-----	1	13200-ZE2-000	2025492
4	ROD ASSY.,CONNECTING (US0.25)	-----	(1)	13200-ZE2-305	2110153
	BOLT, CONNECTING ROD	-----	2	90001-ZE8-000	2160489
6	CLIP, PISTON PIN (18MM)	-----	2	90551-ZE1-000	2539120

ENGINE PARTS

CRAFTSMAN 4250 GENERATOR 919.670040

Honda Engine Model GX270

CAMSHAFT

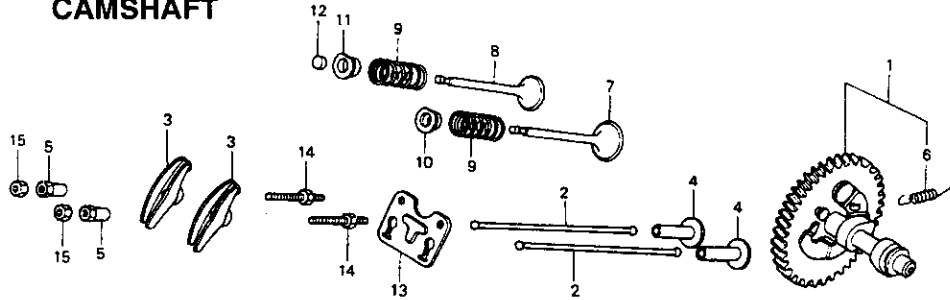

ZH98E0900

Ref	Description	Engine SerialNumber From To	Qty	Part Number	H/C
1	CAMSHAFT ASSY.	----- 1267906	1	14100-ZE3-010	3738291
	CAMSHAFT ASSY.	1267907 -----	1	14100-ZE3-020	5660970
	CAMSHAFT ASSY.	----- 1267906	1	14100-ZE3-305	4730495
2	ROD, PUSH	-----	2	14410-ZE2-013	3337169
3	ARM, VALVE ROCKER	-----	2	14431-ZE2-000	2025591
	ARM, VALVE ROCKER	-----	2	14431-ZE2-010	6206254
4	LIFTER, VALVE	-----	2	14441-ZE2-000	2025609
5	PIVOT, ROCKER ARM	-----	2	14451-ZE1-013	4300901
6	SPRING, WEIGHT RETURN	-----	1	14568-ZE1-000	1426907
7	VALVE, IN.	-----	1	14711-ZE2-000	2025617
8	VALVE, EX.	-----	1	14721-ZE2-000	2025625
9	SPRING, VALVE	-----	2	14751-ZE2-003	2025633
10	RETAINER, IN. VALVE SPRING	-----	1	14771-ZE2-000	2025641
11	RETAINER, EX. VALVE SPRING	-----	1	14773-ZE2-000	2025658
12	ROTATOR, VALVE	-----	1	14781-ZE2-000	2025666
13	PLATE, PUSH ROD GUIDE	-----	1	14791-ZE2-010	3707494
14	BOLT, PIVOT (8MM)	-----	2	90012-ZE0-010	1756954
15	NUT, PIVOT ADJ.	-----	2	90206-ZE1-000	1431287

FLYWHEEL

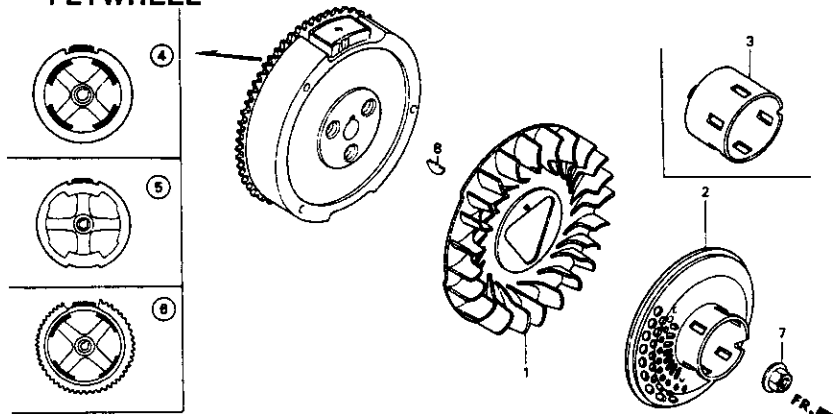

ZH98E1900A

Ref	Description	Engine SerialNumber From To	Qty	Part Number	H/C
1	FAN, COOLING	-----	1	19511-ZE2-000	2026250
2	PULLEY COMP., STARTER (SCREENGRID)	-----	1	28450-ZE2-W11	3678935
5	FLYWHEEL COMP.	-----	1	31100-ZE2-000	2026383
	FLYWHEEL COMP.	-----	1	31100-ZE2-010	5339486
7	NUT, SPECIAL (16MM) (1)	1180428 -----	1	90201-ZE3-V00	5032727
	NUT, SPECIAL (16MM)	----- 1180427	1	90201-ZE3-790	2326908
8	KEY, SPECIAL WOODRUFF (25X18)	-----	1	90741-ZE2-000	2027159

ENGINE PARTS

CRAFTSMAN 4250 GENERATOR 919.670040

Honda Engine Model GX270

RECOIL STARTER

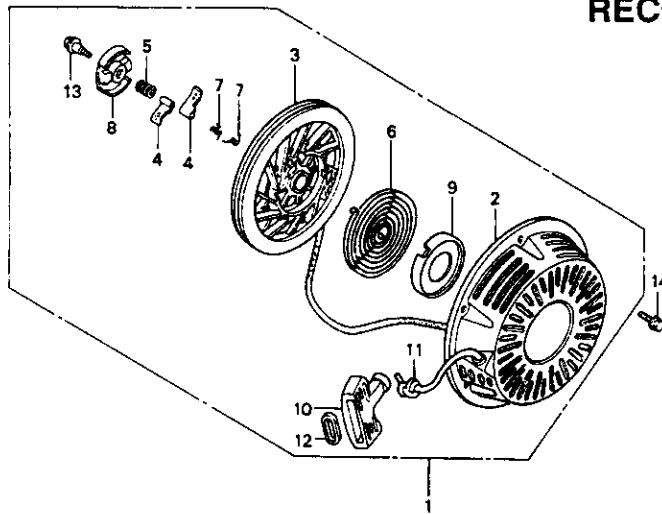

ZH98E1100A

Ref	Description	Engine Serial Number		Qty	Part Number	H/C
		From	To			
1	STARTER ASSY., RECOIL *R8*RED)	-----	-----	1	28400-ZE2-W01ZA	3678844
	STARTER ASSY.,RECOIL*NH1*	-----	-----	1	28400-ZE2-W01ZB	4220315
2	CASE COMP., RECOILSTARTER *R8*(BRIGHTRED)	-----	-----	1	28410-ZE2-W01ZA	3678851
	CASE COMP.,RECOIL STARTER (BLACK) (BLACK)	-----	-----	1	28410-ZE2-W01ZB	4220323
3	PULLEY, RECOIL STARTER	-----	-----	1	28421-ZE2-W01	3678869
4	RATCHET, STARTER	-----	-----	2	28422-ZE2-W01	3678877
5	SPRING, FRICTION	-----	-----	1	28441-ZE2-W01	3678885
6	SPRING, STARTER RETURN	-----	-----	1	28442-ZE2-W01	3678893
7	SPRING, RATCHET	-----	-----	2	28443-ZE2-W01	3678901
8	RETAINER, SPRING	-----	-----	1	28444-ZE2-W01	3678919
9	HOLDER, SPRING	-----	-----	1	28445-ZE2-W01	3678927
10	GRIP, STARTER	-----	1413598	1	28461-ZE2-W01	3678950
	GRIP, STARTER	-----	-----	1	28461-ZE2-W02	6133649
11	ROPE, RECOIL STARTER (NAUSEALT.08550-ZG921-11)	-----	1413598	1	28462-ZE2-W01	3678968
	ROPE, RECOIL STARTER	1413599	-----	1	28462-ZE2-W11	6139729
12	GRIP,REINFORCEMENT	-----	1413598	1	28469-ZE2-W01	3678976
13	SCREW, CENTER	-----	-----	1	90004-ZE2-W01	3679024
14	BOLT, FLANGE (6X8)	-----	-----	3	95701-06008-00	2581353

ENGINE PARTS

CRAFTSMAN 4250 GENERATOR 919.670040

Honda Engine Model GX270

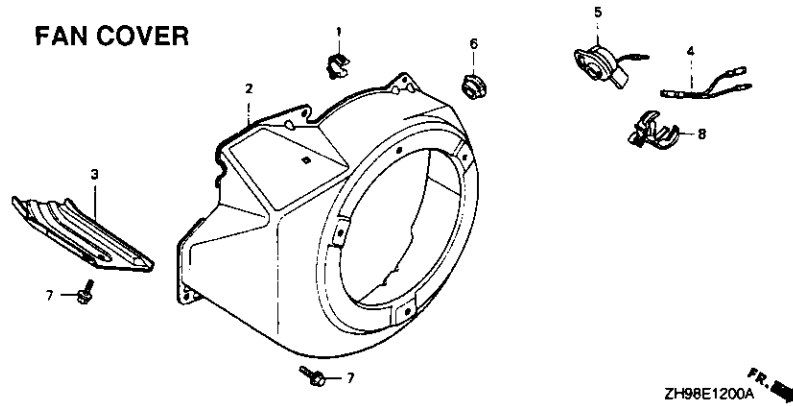

Ref	Description	Engine Serial Number From To	Qty	Part Number	H/C
1	CLIP, TUBE	-----	1	16731-ZE2-003	2026094
2	COVER COMP., FAN"RB"(BRIGHT RED)	-----	1	19610-ZE2-010ZA	4330981
	COVER COMP., FAN"NH1" (BLACK)	-----	1	19610-ZE2-010ZC	4330989
3	SHROUD	-----	1	19631-ZE2-000	4024949
	SHROUD	1205583	1	19631-ZH9-000	3678828
4	SUB-HARNESS	1225386	1	32197-ZH8-003	4193082
5	SWITCH ASSY.,ENGINE STOP	1225386	1	36100-ZE1-015	2787869
	SWITCH ASSY.,ENGINE STOP	1225387	1	36100-ZH7-003	5266184
7	BOLT, FLANGE (6X12) (CT200)	-----	6	90013-883-000	0636845
8	CLIP, WIRE HARNESS	-----	1	90684-ZA0-601	2539138

AIR-CLEANER(1)

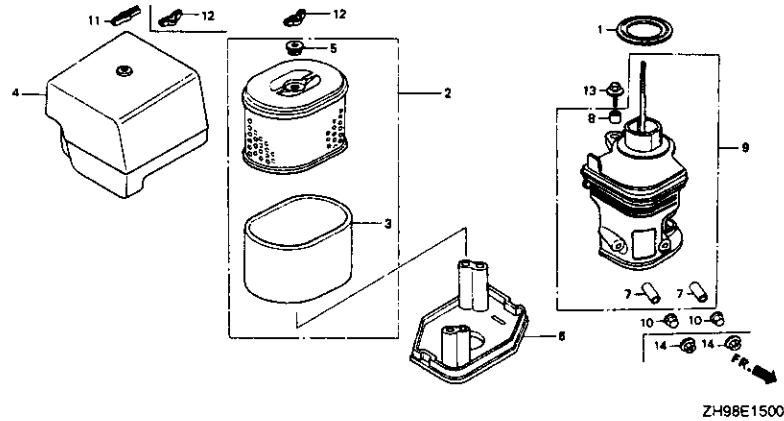

Ref	Description	Engine Serial Number From To	Qty	Part Number	H/C
1	GASKET, ELBOW	-----	1	16271-ZE2-000	2025948
2	ELEMENT, AIR CLEANER	-----	1	17210-ZE2-505	5266721
	ELEMENT, AIR CLEANER	-----	1	17210-ZE2-822	2893899
3	FILTER (OUTER)	-----	1	17218-ZE2-505	5196308
4	COVER, AIR CLEANER	-----	1	17231-ZH9-820	3690054
5	GROMMET, AIR	-----	1	17232-891-000	0999763
7	COLLAR, AIRCLEANER	-----	2	17238-ZE2-310	2384105
8	COLLAR B, AIR	-----	1	17239-ZE1-000	1427533
9	ELBOW COMP.,	-----	1	17410-ZE2-020	2414290
11	WINGNUT (6MM)	1096095	1	90203-ZA0-800	1742238
12	WINGNUT, TOOL	1096095	1	90325-044-000	0127720
		1096096	2	90325-044-000	0127720
13	BOLT-WASHER	-----	1	93404-06020-08	2410694
14	NUT, FLANGE(6MM)	-----	2	94050-06000	0471623

ENGINE PARTS

CRAFTSMAN 4250 GENERATOR 919.670040

Honda Engine Model GX270

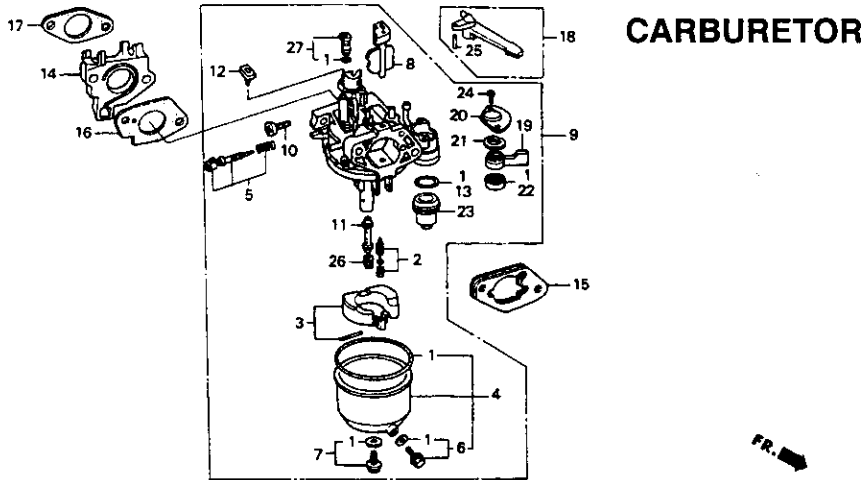

ZH98E1400A

Ref	Description	Engine SerialNumber From To	Qty	Part Number	H/C
1	GASKET SET	-----	1	16010-ZE2-812	3511383
2	VALVE SET,FLOAT	-----	1	16011-ZA0-931	2059236
3	FLOAT SET	-----	1	16013-ZA0-931	2059244
4	CHAMBER SET,FLOAT	----- 1173689	1	16015-ZE2-005	2157493
	CHAMBER SET,FLOAT	-----	1	16015-ZE8-005	2089993
5	SCREW SET	-----	1	16016-ZH7-W01	4219879
6	SCREW SET, DRAIN	-----	1	16024-ZE1-811	1672187
7	SCREW SET B	-----	1	16028-ZE0-005	1441518
8	CHOKE SET	-----	1	16044-ZE2-005	2090017
9	CARBURETOR ASSY.(BE75B B)	-----	1	16100-ZH9-W21	5250782
10	SCREW, THROTTLE STOP	-----	1	16124-ZE0-005	1441559
11	NOZZLE, MAIN	-----	1	16166-ZH9-W20	4241808
12	COLLAR SET	-----	1	16172-ZE3-W10	3738358
13	O-RING	-----	1	16173-001-004	0005652
14	INSULATOR, CARBURETOR	-----	1	16211-ZE2-000	2025906
15	SPACER COMP.,	-----	1	16220-ZA0-702	2686533
16	GASKET, CARBURETOR	-----	1	16221-ZA0-800	3678620
17	GASKET, INSULATOR	-----	1	16223-ZA0-800	3678638
18	LEVER COMP.,CHOKE(STD)	-----	1	16610-ZE1-000	1440114
19	LEVER, VALVE	----- 1173689	1	16953-ZE1-406	5167358
	LEVER, VALVE	1173690 -----	1	16953-ZE1-812	5140876
20	PLATE, LEVER SETTING	----- BF75B	1	16954-ZE1-812	5148135
		BF75B B -----	1	16954-ZE1-812	5148135
21	SPRING, VALVE LEVER	-----	1	16956-ZE1-811	1807809
22	VALVE GASKET,	-----	1	16957-ZE1-812	3440708
23	CUP, FUEL STRAINER	-----	1	16967-ZE0-811	1441583
24	SCREW, PAN (3X6)	1173690 -----	2	93500-03006-0H	0561654
	SCREW, PAN (3X8)	----- 1173689	2	93500-03008-0G	0420505
25	PIN, SPRING (2X12)	-----	1	94305-20122	1441591
26	JET, MAIN (#80)	-----	(1)	99101-ZH7-0800	4335691
	JET, MAIN (#80)	-----	(1)	99101-ZH8-0800	5947122
	JET, MAIN (#82)	-----	(1)	99101-ZH8-0820	5947130
	JET, MAIN(#85)	-----	1	99101-ZH8-0850	5947148
27	JET SET,PILOT(#40)	-----	1	99204-ZE2-0400	3683141

ENGINE PARTS

CRAFTSMAN 4250 GENERATOR 919.670040

Honda Engine Model GX270

MUFFLER (1)

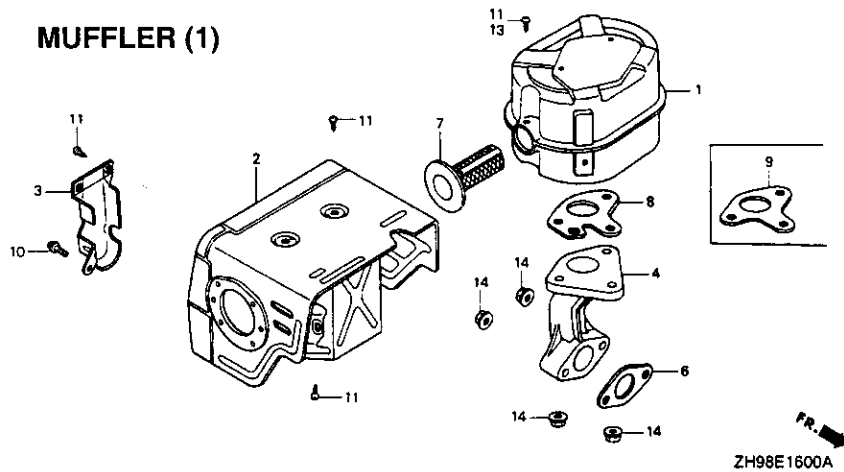

Ref	Description	Engine SerialNumber From To	Qty	Part Number	H/C
1	MUFFLER COMP.	-----	1	18310-ZE2-W00	3678745
2	PROTECTOR COMP.,MUFFLER	-----	1	18320-ZE2-W01	4613642
3	PROTECTOR, EX.	-----	1	18323-ZE2-W00	3678786
4	PIPE, EX.	-----	1	18330-ZE2-W00	3678794
6	GASKET, EX.PIPE	-----	1	18333-ZE3-800	3520194
	GASKET, EX. PIPE (WACKER)	-----	1	18333-ZK6-Y00	5164199
7	ARRESTER, SPARK	-----	1	18355-ZE2-010	2482594
8	GASKET, MUFFLER (ARRESTER)	-----	1	18381-ZE2-W10	3678802
10	BOLT, FLANGE(6X12)(CT200)	-----	1	90013-883-000	0636845
11	SCREW, TAPPING(5X8)	-----	7	90050-ZE1-000	1431105
14	NUT, FLANGE (8MM)	-----	5	94050-08000	0481143

IGNITION COIL

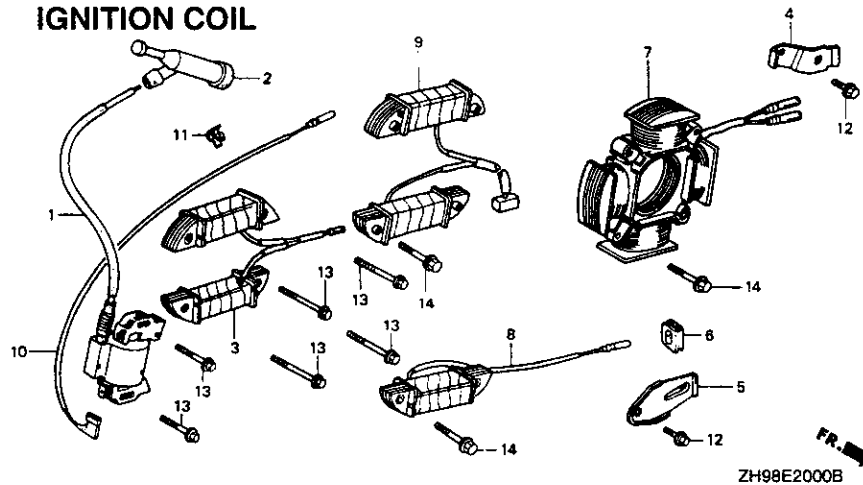

Ref	Description	Engine SerialNumber From To	Qty	Part Number	H/C
1	COIL ASSY.,IGNITION	-----	1	30500-ZE2-023	4545927
2	CAP ASSY.,NOISE SUPPRESSOR	-----	1	30700-ZE1-013	3526837
6	GROMMET, WIRE	-----	1	31512-ZE2-000	2026557
10	WIRE, STOP SWITCH (370MM)	-----	1	36101-ZE1-010	3684032
13	BOLT, FLANGE (6X28)	-----	2	90015-883-000	0636852

ENGINE PARTS

CRAFTSMAN 4250 GENERATOR 919.670040

Honda Engine Model GX270

CONTROL

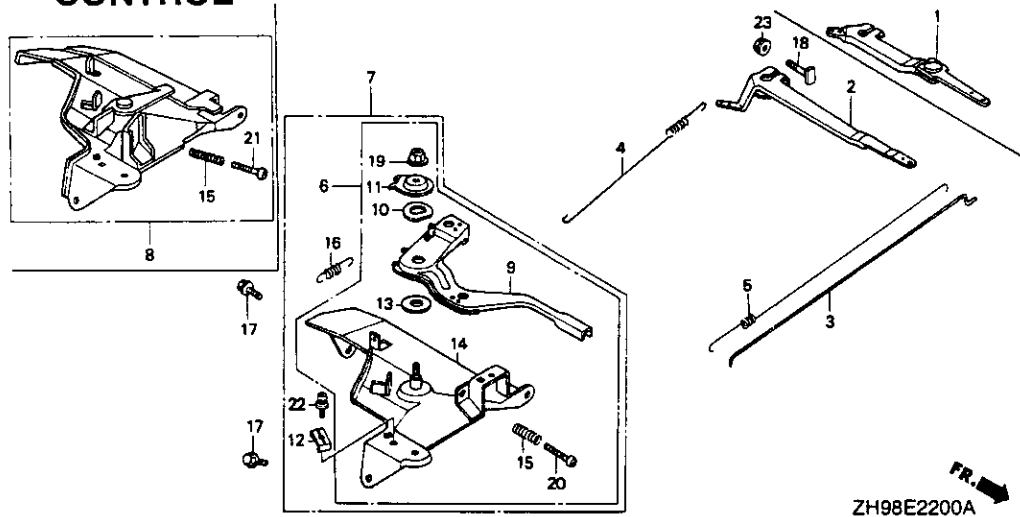

Ref	Description	Engine SerialNumber From To	Qty	Part Number	H/C
2	ARM, GOVERNOR	-----	1	16551-ZE2-000	2026003
3	ROD, GOVERNOR	-----	1	16555-ZE2-000	2026011
4	SPRING, GOVERNOR	-----	1	16561-ZE2-000	2026029
5	SPRING, THROTTLE RETURN	-----	1	16562-ZE2-000	2026037
7	CONTROL ASSY. (REMOTE)	-----	1	16570-ZE2-W20	3678653
9	LEVER, CONTROL	-----	1	16571-ZE2-W00	3678661
10	SPRING, LEVER	-----	1	16574-ZE1-000	1427384
11	WASHER, CONTROL LEVER	-----	1	16575-ZE2-W00	3678679
12	HOLDER, CABLE	-----	1	16576-891-000	0800466
13	SPACER, CONTROL LEVER	-----	1	16578-ZE1-000	1427400
14	BASE COMP., CONTROL	-----	1	16581-ZE2-W00	3678687
15	SPRING, CONTROL ADJUSTING	-----	1	16584-883-300	0636431
16	SPRING, CABLE RETURN	-----	1	16592-883-310	0743203
17	BOLT, FLANGE (6X12) (CT200)	-----	2	90013-883-000	0636845
18	BOLT, GOVERNOR ARM	-----	1	90015-ZE5-010	2418671
19	NUT, SELF-LOCK (6MM)	-----	1	90114-SA0-000	1410182
20	SCREW, PAN (5X28)	-----	1	93500-05028-0A	0171819
22	SCREW, PAN (5X16)	-----	1	93500-05016-0A	0145557
23	NUT, FLANGE (6MM)	-----	1	94050-06000	0471623

NOTES

NOTES

NOTES

Dear Customer,

In manufacturing this product, many steps have been taken to provide you with the highest quality. Unfortunately, errors or omissions occasionally occur. In the event that you find a missing or defective part, please contact your nearest Sears store.

SERVICE AND REPAIR PARTS
CALL 1-800-665-4455 *

Keep this number handy should you require a service call or need to order repair parts.

If ordering parts make sure you have the name, make and model no. of the merchandise and the name and number of the part you wish to order.

* If calling locally, please use one of the following numbers:

- | | |
|----------------------|---------------------|
| Regina - 566-5124 | Montreal - 333-5740 |
| Toronto - 744-4900 | Halifax - 454-2444 |
| Kitchener - 894-7590 | Ottawa - 738-4440 |
| Vancouver - 420-8211 | |

If you have any suggestions that would help us to improve our assembly/operation instructions, or this product, please write them down and mail it to:

Sears Canada Inc.
222 Jarvis Street
Toronto, Ontario
M5B 2B8

Attention: Buyer Dept: D671

Model No. _____

NAME _____

ADDRESS _____

POSTAL CODE _____ PHONE # _____

COMMENTS

