

# Panasonic®

## Portable Stereo CD System

### Operating Instructions

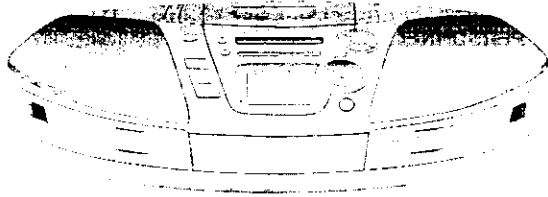

Model No. **RX-ES25**  
**RX-ES20**

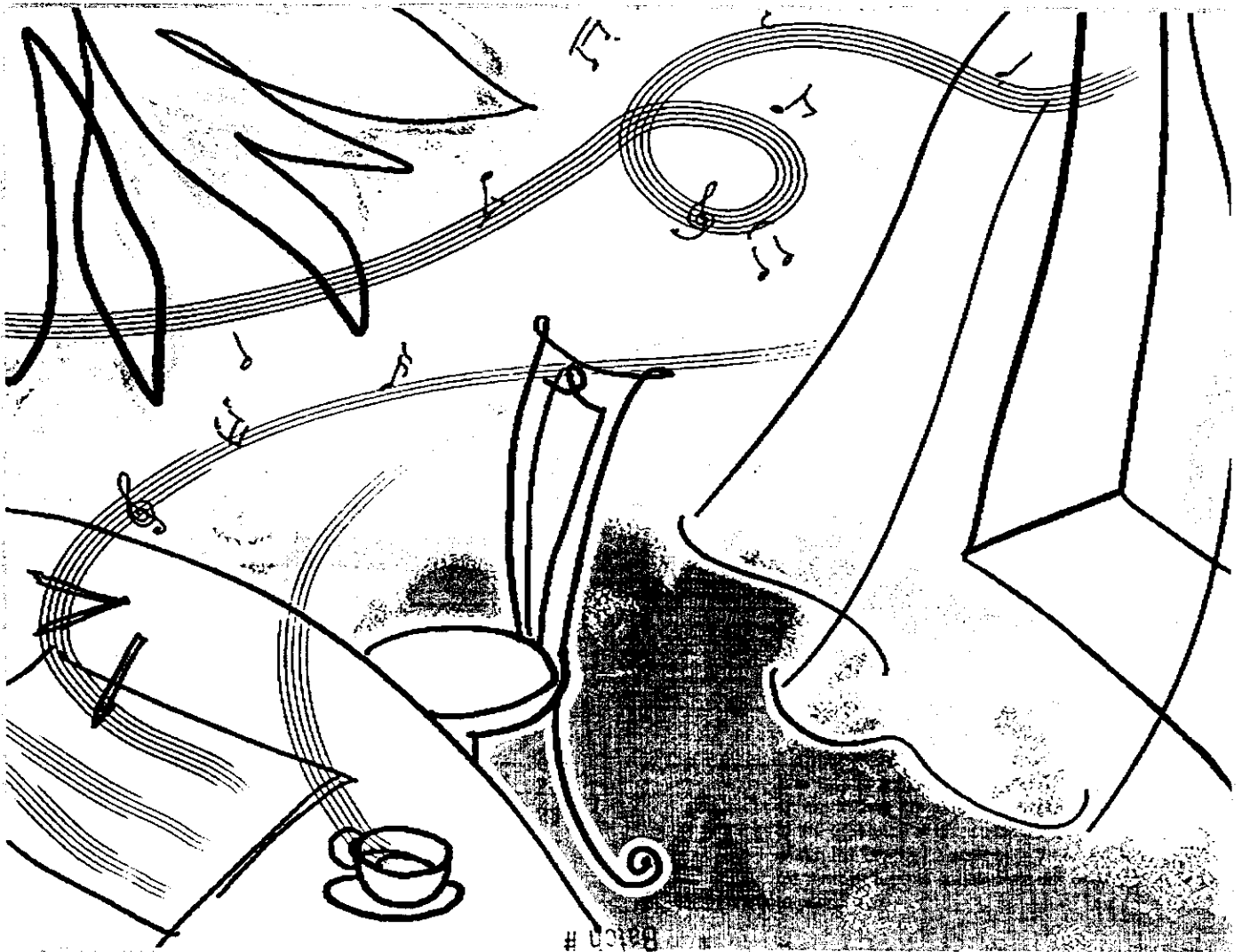

COMPACT  
**disc**  
DIGITAL AUDIO

Before connecting, operating or adjusting this product, please read these instructions completely. Please keep this manual for future reference.

## Dear customer

Thank you for purchasing this product.  
For optimum performance and safety, please read these instructions carefully.

Before use

The model number and serial number of this product can be found on either the back or the bottom of the unit.  
Please note them in the space provided below and keep for future reference.

MODEL NUMBER \_\_\_\_\_

SERIAL NUMBER \_\_\_\_\_

### User memo:

DATE OF PURCHASE \_\_\_\_\_

DEALER NAME \_\_\_\_\_

DEALER ADDRESS \_\_\_\_\_

TELEPHONE NUMBER \_\_\_\_\_

## Supplied Accessories



Please check and identify the supplied accessories.  
Use numbers indicated in parentheses when asking for replacement parts.

*(Only for U.S.A.)*

*To order accessories contact 1-800-332-5368 or web site (<http://www.panasonic.com>).*

- AC power cord (polarized) ..... 1pc.  
(RJA0065-A)

### Note

The included AC power supply cord is for use with this unit only.  
Do not use it with other equipment.

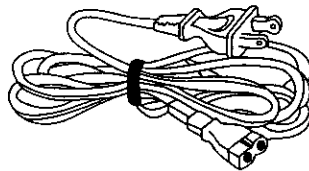

- Remote control transmitter (EUR648251) ..... 1pc.

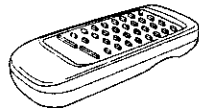

## CAUTION!

THIS PRODUCT UTILIZES A LASER.  
USE OF CONTROLS OR ADJUSTMENTS OR PERFORMANCE OF PROCEDURES OTHER THAN THOSE SPECIFIED HEREIN MAY RESULT IN HAZARDOUS RADIATION EXPOSURE.

DO NOT OPEN COVERS AND DO NOT REPAIR YOURSELF. REFER SERVICING TO QUALIFIED PERSONNEL.

## CAUTION:

TO PREVENT ELECTRIC SHOCK MATCH WIDE BLADE OF PLUG TO WIDE SLOT, FULLY INSERT.

## WARNING:

TO REDUCE THE RISK OF FIRE, ELECTRIC SHOCK OR PRODUCT DAMAGE, DO NOT EXPOSE THIS APPLIANCE TO RAIN, SPLASHING, DRIPPING OR MOISTURE.

**Before use**

**Supplied Accessories** ..... 2  
**Precautions** ..... 3  
**Use of Batteries** ..... 5  
**Power Sources** ..... 6  
**Memory Batteries** ..... 6  
**Location of Controls** ..... 7  
**The Remote Control** ..... 8  
**Setting the Clock** ..... 9  
**Using Headphones** ..... 9

**Listening**

**The Radio** ..... 10  
 Normal tuning ..... 10  
 Using auto scan ..... 10  
 Preset tuning ..... 11  
**CDs** ..... 12  
 Other modes of play ..... 13  
**Cassettes** ..... 15

**Recording**

**Tips on Recording** ..... 15  
**Recording CDs** ..... 16  
 Normal recording ..... 16  
 ALL-REC ..... 17  
 1-REC ..... 18  
**Recording the Radio** ..... 18

**Sound Quality and Sound Field**

**Sound Quality** ..... 19  
**3-D sound with the Sound Virtualizer** ..... 19

**Timer**

**The Play and Record Timer** ..... 20  
**The Sleep Timer** ..... 21  
**The Timer Fader** ..... 21

**Reference**

**Maintenance** ..... 21  
**Troubleshooting** ..... 22  
**Product Service** ..... 23  
**Specifications** ..... Back cover

THE FOLLOWING APPLIES ONLY IN THE U.S.A.:

**CAUTION:**

This equipment has been tested and found to comply with the limits for a Class B digital device, pursuant to Part 15 of the FCC Rules.

These limits are designed to provide reasonable protection against harmful interference in a residential installation. This equipment generates, uses and can radiate radio frequency energy and, if not installed and used in accordance with the instructions, may cause harmful interference to radio communications. However, there is no guarantee that interference will not occur in a particular installation. If this equipment does cause harmful interference to radio or television reception, which can be determined by turning the equipment off and on, the user is encouraged to try to correct the interference by one of the following measures:

- Reorient or relocate the receiving antenna.
- Increase the separation between the equipment and receiver.
- Connect the equipment into an outlet on a circuit different from that to which the receiver is connected.
- Consult the dealer or an experienced radio/TV technician for help.

Any unauthorized changes or modifications to this equipment would void the user's authority to operate this device.

This device complies with Part 15 of the FCC Rules. Operation is subject to the following two conditions: (1) This device may not cause harmful interference, and (2) this device must accept any interference received, including interference that may cause undesired operation.

Before use

The following mark and symbols are located on the bottom of the unit.



**CAUTION**

**RISK OF ELECTRIC SHOCK**

**DO NOT OPEN**



CAUTION: TO REDUCE THE RISK OF ELECTRIC SHOCK, DO NOT REMOVE SCREWS. NO USER-SERVICEABLE PARTS INSIDE. REFER SERVICING TO QUALIFIED SERVICE PERSONNEL.

The lightning flash with arrowhead symbol, within an equilateral triangle, is intended to alert the user to the presence of uninsulated "dangerous voltage" within the product's enclosure that may be of sufficient magnitude to constitute a risk of electric shock to persons.

The exclamation point within an equilateral triangle is intended to alert the user to the presence of important operating and maintenance (servicing) instructions in the literature accompanying the appliance.

## Precautions

Before using this unit please read these operating instructions carefully. Take special care to follow the warnings indicated on the unit itself as well as the safety suggestions listed below. Afterwards keep them handy for future reference.

## Safety

1. **Power Source**—The unit should be connected to power supply only of the type described in the operating instructions or as marked on the unit.
2. **Polarization**—If the unit is equipped with a polarized AC power plug (a plug having one blade wider than the other), that plug will fit into the AC outlet only one way. This is a safety feature. If you are unable to insert the plug fully into the outlet, try reversing the plug. If the plug should still fail to fit, contact your electrician to replace your obsolete outlet. Do not defeat the safety purpose of the polarized plug.
3. **Power Cord Protection**—AC power supply cords should be routed so that they are not likely to be walked on or pinched by items placed upon or against them. Never take hold of the plug or cord if your hand is wet, and always grasp the plug body when connecting or disconnecting it.
4. **Nonuse Periods**—When the unit is not used, turn the power off. When left unused for a long period of time, the unit should be unplugged from the household AC outlet.

## Installation

### Environment

1. **Water and Moisture**—Do not use this unit near water—for example, near a bathtub, washbowl, swimming pool, or the like. Damp basements should also be avoided.
2. **Condensation**—Moisture may form on the lens in the following conditions...
  - immediately after a heater has been turned on.
  - in a steamy or very humid room.
  - when the unit is suddenly moved from a cold environment to a warm one.If moisture forms inside this unit, it may not operate properly. To correct this problem, turn on the power and wait about one hour for the moisture to evaporate.
3. **Heat**—The unit should be situated away from heat sources such as radiators and the like. It also should not be placed in temperatures less than 5°C (41°F) or greater than 35°C (95°F).

## Placement

1. **Ventilation**—The unit should be situated so that its location or position does not interfere with its proper ventilation. Allow 10 cm (4") clearance from the rear of the unit.
2. **Foreign Material**—Care should be taken so that objects do not fall into and liquids are not spilled into the unit. Do not subject this unit to excessive smoke, dust, mechanical vibration, or shock.
3. **Magnetism**—The unit should be situated away from equipment or devices that generate strong magnetic fields.
4. **Stacking**—Do not place heavy objects, other than system components, on top of the unit.
5. **Surface**—Place the unit on a flat, level surface.
6. **Carts and Stands**—The unit should be used only with a cart or stand that is recommended by the manufacturer. The unit and cart combination should be moved with care. Quick stops, excessive force, and uneven surfaces may cause the unit and cart combination to overturn.
7. **Wall or Ceiling Mounting**—The unit should not be mounted to a wall or ceiling, unless specified in this operating instructions.



## Maintenance

Clean the cabinet, panel and controls with a soft cloth lightly moistened with mild detergent solution. Do not use any type of abrasive pad, scouring powder or solvent such as alcohol or benzene.

## Service

1. **Damage Requiring Service**—The unit should be serviced by qualified service personnel when:
  - (a) The AC power supply cord or the plug has been damaged; or
  - (b) Objects have fallen or liquid has been spilled into the unit; or
  - (c) The unit has been exposed to rain; or
  - (d) The unit does not appear to operate normally or exhibits a marked change in performance; or
  - (e) The unit has been dropped, or the enclosure damaged.
2. **Servicing**—The user should not attempt to service the unit beyond that described in the operating instructions. All other servicing should be referred to an authorized service personnel.

**For the address of an authorized servicer:**  
**In the U.S.A. 1-800-211-7262 or web site**  
**(<http://www.panasonic.com>)**  
**In Canada 905-624-5505 or web site**  
**([www.panasonic.ca](http://www.panasonic.ca))**

### Listening caution



Selecting fine audio equipment such as the unit you've just purchased is only the start of your musical enjoyment. Now it's time to consider how you can maximize the fun and excitement your equipment offers. This manufacturer and the Electronic Industries Association's Consumer Electronics Group want you to get the most out of your equipment by playing it at a safe level. One that lets the sound come through loud and clear without annoying blaring or distortion—and, most importantly, without affecting your sensitive hearing.

We recommend you to avoid prolonged exposure to excessive noise.

Sound can be deceiving. Over time your hearing "comfort level" adapts to higher volumes of sound. So what sounds "normal" can actually be loud and harmful to your hearing.

Guard against this by setting your equipment at a safe level **BEFORE** your hearing adapts.

To establish a safe level:

- Start your volume control at a low setting.
- Slowly increase the sound until you can hear it comfortably and clearly, and without distortion.

Once you have established a comfortable sound level:

- Set the dial and leave it there.

Taking a minute to do this now will help to prevent hearing damage or loss in the future. After all, we want you listening for a lifetime.

- If this unit is not used for a long period of time or is used only from an AC power source, remove all the batteries to prevent potential damage due to possible battery leakage.
- Align the poles (+ and -) properly when inserting the batteries.
- Do not mix old and new batteries or different types of batteries.
- Do not recharge ordinary dry cell batteries.
- Do not heat or disassemble the batteries. Do not allow them to contact flame or water.
- Do not keep together with metallic objects such as necklaces.
- Do not use rechargeable type batteries.
- Do not use batteries if the covering has been peeled off.

Mishandling of batteries can damage other items, cause damage to the unit, and may cause a fire through short-circuiting or electrolyte leakage.

If electrolyte leaks from the batteries, consult your dealer.

Wash thoroughly with water if electrolyte comes in contact with any part of your body.

## Power Sources

Before use

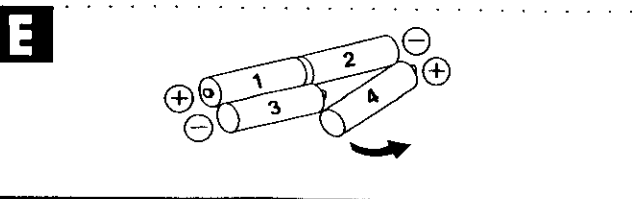
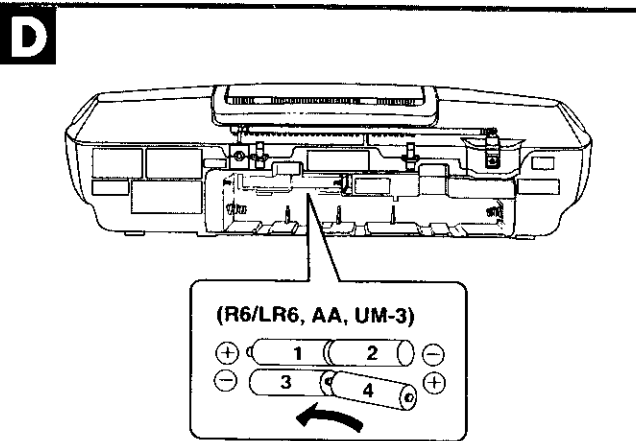
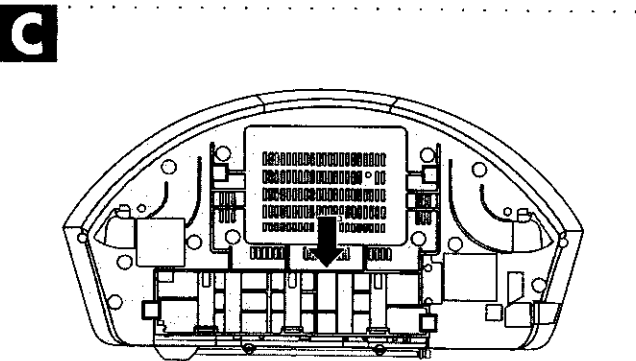
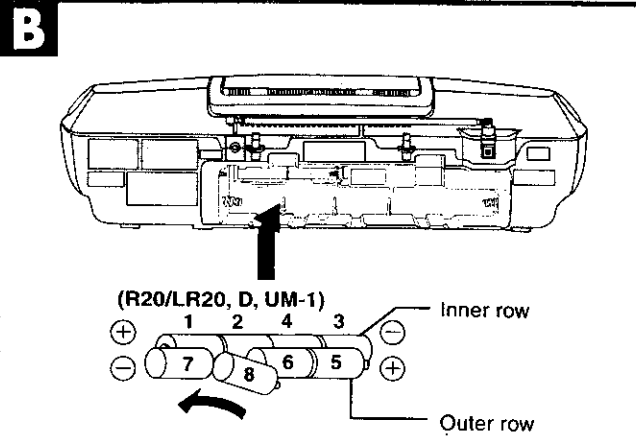
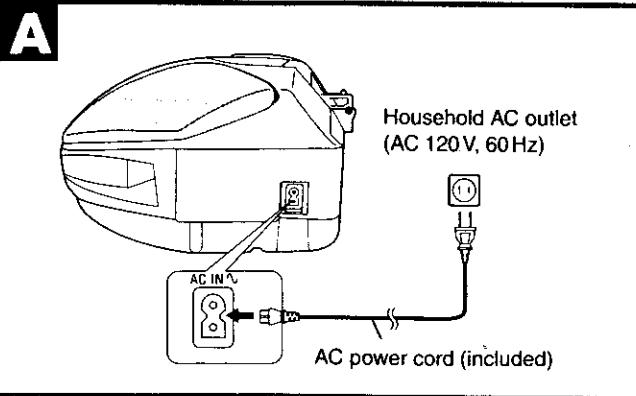

### A Operating the unit on AC power

Connect the AC power cord.

#### Conserving power

The unit consumes 3.1W for RX-ES25 and 2.1W for RX-ES20 even when it is turned off with [POWER ]. To save power when the unit is not to be used for a long time, unplug it from the household AC outlet. Remember to reset the radio stations and any other memory items before using the unit again if you haven't inserted memory batteries.

### B Using batteries (not included)

Disconnect the AC power cord from the unit to operate on battery power.

The remote control cannot turn the unit on when batteries are used.

### C Removing the batteries

Open the battery cover, insert a finger into the hole in the bottom of the unit and push out.

#### Battery life

" " flashes on the display when the batteries are running down. Then, the unit turns itself off and displays "U01". Replace all the batteries with new ones.

### D Memory Batteries (not included)

Memory batteries retain memory (clock/timer/CD/radio settings) during power supply interruption.

These batteries do not power the unit.

#### Replacing the batteries

- The memory batteries last about one year.
- Connect the unit to AC power before replacing the batteries.
- Extend the memory battery life by always pressing [POWER ] to turn the unit off before disconnecting the unit from the AC power source or replacing the power batteries.

### E Removing the batteries

Lift the negative end of the number 4 battery to remove batteries.

**A Basic controls**

Number                      Designation                      Reference Page

- ① **Standby/on switch (POWER U/I)**  
Press to switch the unit from on to standby mode or vice versa. In standby mode, the unit is still consuming a small amount of power.
- ② **Preset equalizer button (PRESET EQ) .....** 19
- ③ **Play timer/record timer button (PLAY/REC) .....** 20
- ④ **Clock/timer button (CLOCK/TIMER) .....** 9, 20
- ⑤ **Volume control buttons (+, - VOLUME) .....** 10, 12, 15
- ⑥ **Display panel**
- ⑦ **Time adjust/preset channel select/CD track select dial (TIME/PRESET TUNE ← CD SKIP →) .....** 9, 11, 12, 20
- ⑧ **Remote control signal sensor (SENSOR) .....** 8
- ⑨ **Speaker**

**Note**

These speakers do not have magnetic shielding. Do not place them near televisions, personal computers or other devices easily influenced by magnetism.

**B Tuner/CD controls**

Number                      Designation                      Reference Page

- ⑩ **Band button (TUNER BAND) .....** 10, 11
- ⑪ **CD play/pause button (▶/|| CD) .....** 12
- ⑫ **CD recording mode button (CD REC MODE) ....** 17, 18
- ⑬ **CD program/clear, tuner preset button (MEMORY - CLEAR) .....** 11, 14
- ⑭ **CD tray**
- ⑮ **Tuning/CD search buttons (REW / - / ◀, ▶ / + / FF) .....** 10, 12
- ⑯ **CD mode select/stop button (■ TAPE/CD) .....** 12, 13
- ⑰ **Preset channel select/CD track select dial (TIME/PRESET TUNE ← CD SKIP →) .....** 11, 12
- ⑱ **CD tray open/close button (▲ CD) .....** 12

**C Cassette deck controls**

Number                      Designation                      Reference Page

- ⑲ **Deck eject button (▲ DECK) .....** 15
- ⑳ **Record/record pause button (●/||) .....** 16, 17, 18
- ㉑ **Cassette play button (▶ TAPE) .....** 15
- ㉒ **Tape mode select/stop button (■ TAPE/CD) ....** 15, 16
- ㉓ **Deck**
- ㉔ **Rewind/fast-forward buttons (REW / - / ◀, ▶ / + / FF) .....** 15

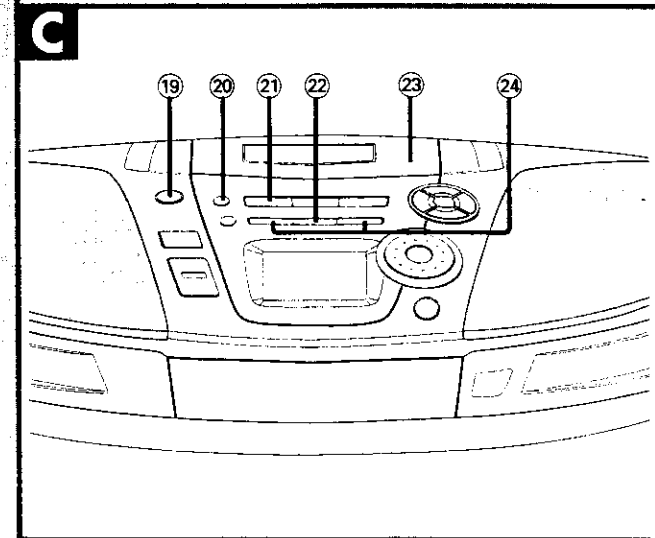
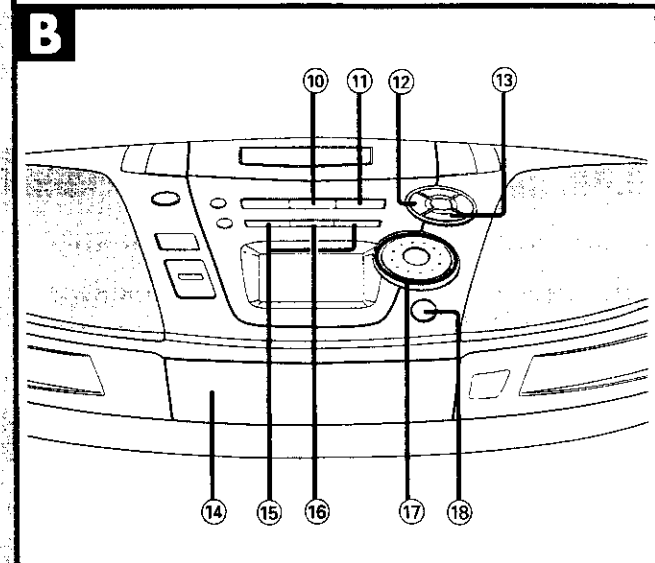
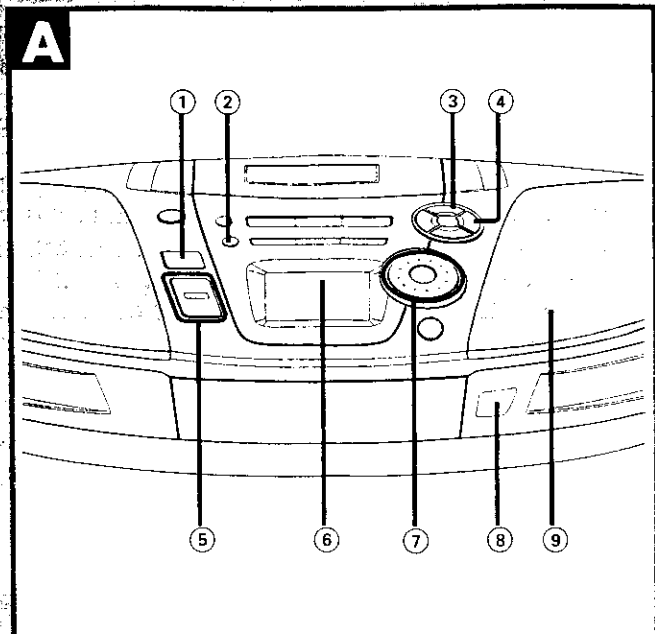

Before use

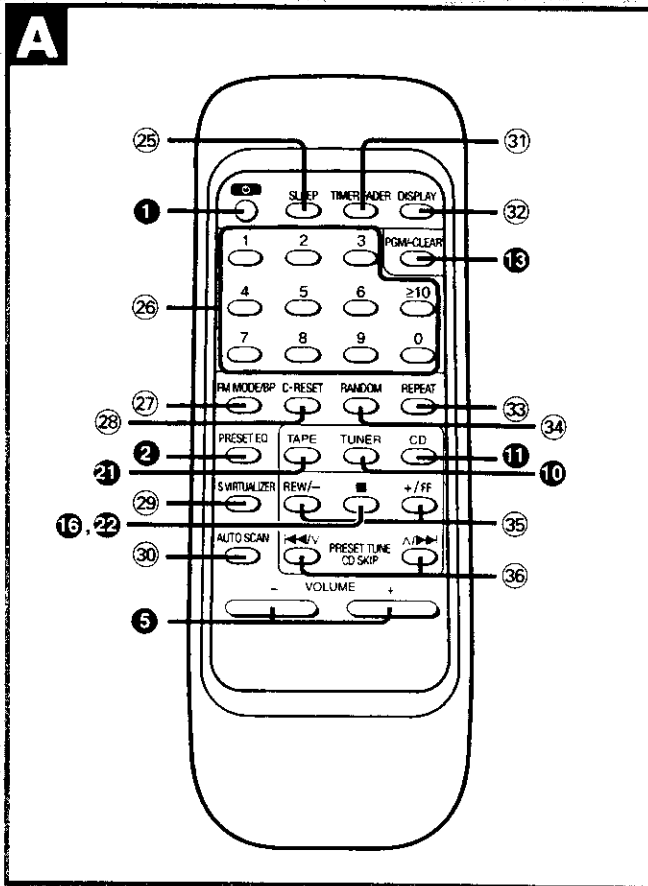

## A Buttons

Number	Designation	Reference Page
25	Sleep timer button (SLEEP)	21
26	Numbered buttons	11, 13, 14
27	FM mode/BP button (FM MODE/BP)	10, 18
28	Tape counter reset button (C-RESET)	15
29	Sound virtualizer button (S.VIRTUALIZER)	19
30	Auto scan button (AUTO SCAN)	10
31	Timer fader button (TIMER FADER)	21
32	Display select button (DISPLAY)	9, 15
33	Repeat button (REPEAT)	13
34	Random play button (RANDOM)	13
35	Tuning/rewind/fast-forward buttons (REW/-, +/FF)	10, 15
36	Preset tuning/preset scan/CD skip/search buttons ( ◀◀/V, ^/▶▶ )	11, 12

When the unit is supplied with AC power, buttons 1, 2, 5, 10, 11, 13, 16, 21 and 22 function in the same way as the controls on the main unit. To save power, the unit cannot be turned on from the remote control when batteries are used.

## B Batteries (not included)

Insert so the poles (+ and -) match those in the remote control.

Remove if the remote control is not going to be used for a long period of time. Store in a cool, dark place. Replace if the unit does not respond to the remote control even when held close to the front panel.

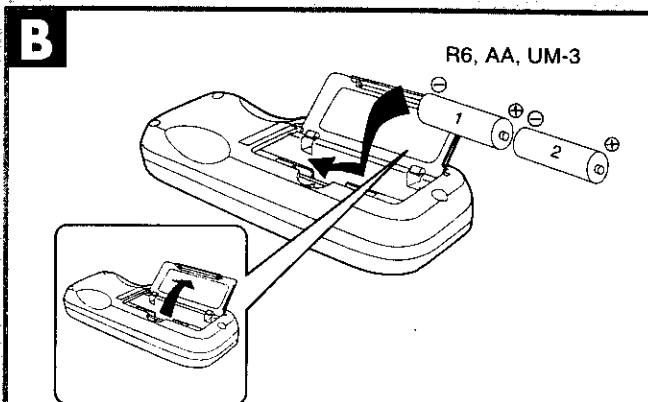

## C Use

Aim at the sensor, avoiding obstacles, at a maximum range of 7 meters directly in front of the unit.

- Keep the transmission window and the unit's sensor free from dust.
- Operation can be affected by strong light sources, such as direct sunlight, and the glass doors on cabinets.

### Do not

- put heavy objects on the remote control.
- take the remote control apart.
- spill liquids onto the remote control.

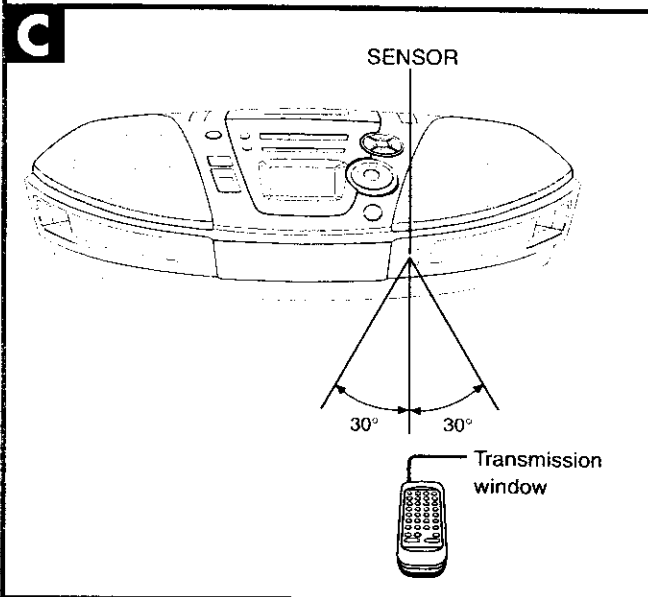



## Setting the Clock

This is a twelve hour clock.

The example shows how to set the clock to 1:30 p.m.

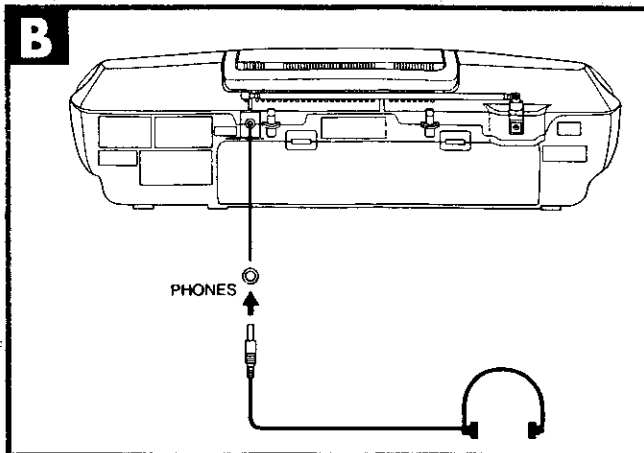
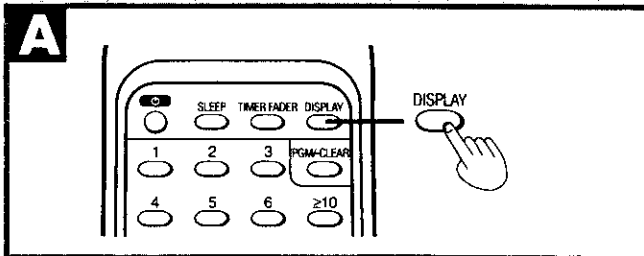
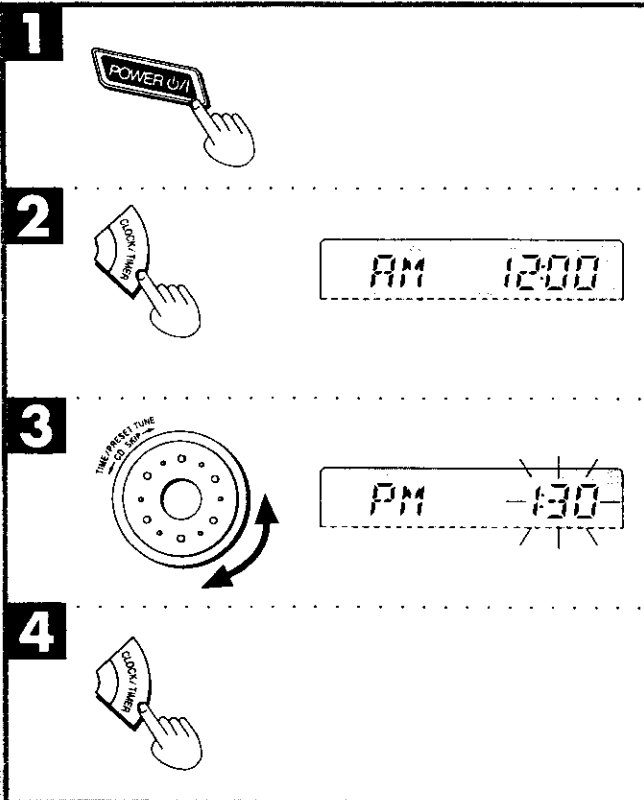
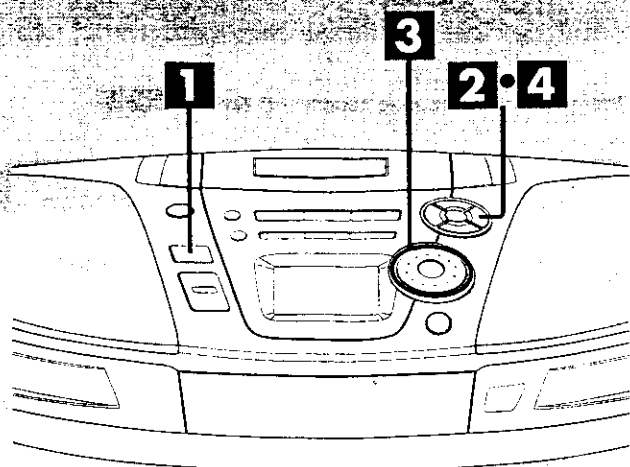

**1** Press [POWER] to turn the unit on.

**2** Press [CLOCK/TIMER] to select clock.  
Each time you press the button:

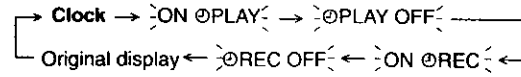

**3** Within 10 seconds

Turn [TIME/PRESET TUNE -- CD SKIP --] to set the time.

**4** Press [CLOCK/TIMER] to start the clock.  
The original display is restored shortly after.

### When batteries are used

The unit cannot be turned on with the remote control.

### A Displaying the clock

Remote control only

Press [DISPLAY].

### B Using Headphones (not included)

Reduce volume before connection.

Plug type: 3.5 mm (1/8") stereo

### Note

Avoid listening for prolonged periods of time to prevent hearing damage.

## The Radio

Preparation: (when using batteries) Press [POWER ].

### A Normal tuning

- 1 Press [TUNER BAND] to select "FM" or "AM".  
(Unit comes on when using AC power.)  
Each time you press the button:  
AM ↔ FM
- 2 Press [REW/-/◀◀] or [▶▶/+ /FF] to select a station.  
"ST" is displayed during FM stereo broadcasts.
- 3 Press [+ , - VOLUME] to adjust the volume.

### B Using auto scan

Remote control only

You can search for a station by listening to all tuned-in stations for 8 seconds each.

- 1 Press [TUNER] to select "FM" or "AM".
- 2 Press [AUTO SCAN].  
Auto scan starts.
- 3 Press [AUTO SCAN] when you find the desired station.

Auto scan ends when it reaches the original frequency again.  
To stop during the process, press [AUTO SCAN].

### C If noise is excessive in FM

Remote control only

Press [FM MODE/BP] to display "**MONO**".

Monaural sound is selected ("ST" goes off) and noise reduces when reception is weak.

Press [FM MODE/BP] again to cancel the mode.

### Auto-tuning

Press and hold [REW / - / ◀◀] or [▶▶ / + / FF] until the frequency starts changing rapidly.

The frequency stops when it finds a station. (Interference may also cause it to stop. Start auto-tuning again if this occurs.)

To stop auto-tuning

Press [REW / - / ◀◀] or [▶▶ / + / FF].

### D To improve reception

FM: Change the length and direction of the antenna.

AM: Change the facing of the unit.

### Note

- AM reception is briefly interrupted if [▲ DECK] is pressed.
- To improve reception when using the unit in a building or vehicle, use it near a window.

### To receive FM broadcasts allocated in 0.1MHz

Main unit only

First press [TUNER BAND] to select "AM". Now, press and hold [TUNER BAND]. The display changes in a few seconds to show the current lowest FM frequency. Continue to hold down the button.

The minimum frequency changes and the step is changed at the same time. Changing the step erases all preset stations.

Repeat the above to change the step back

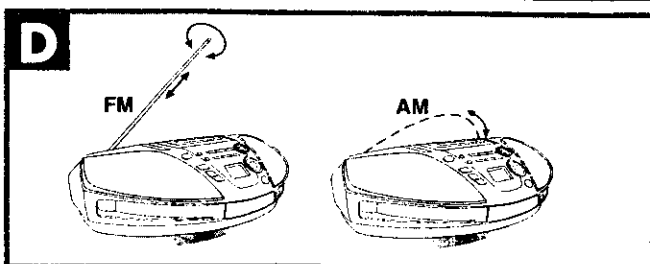
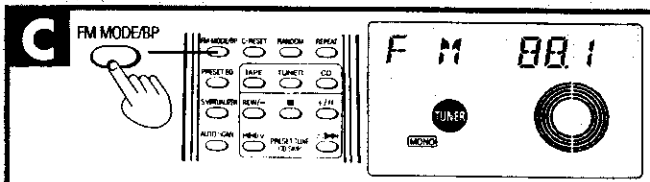
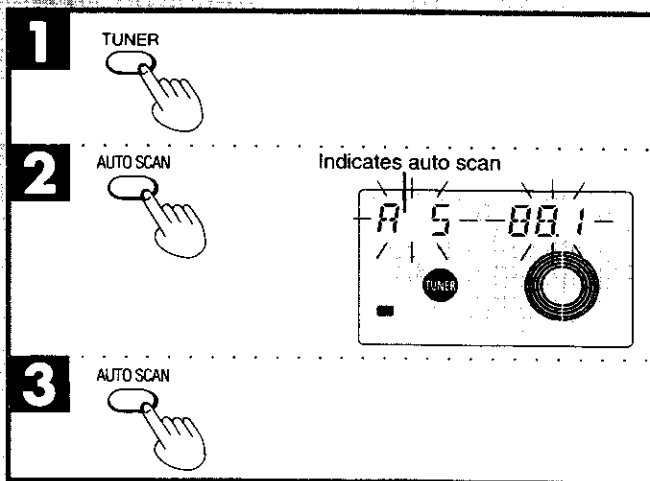
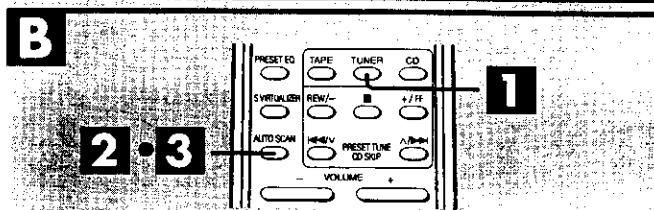
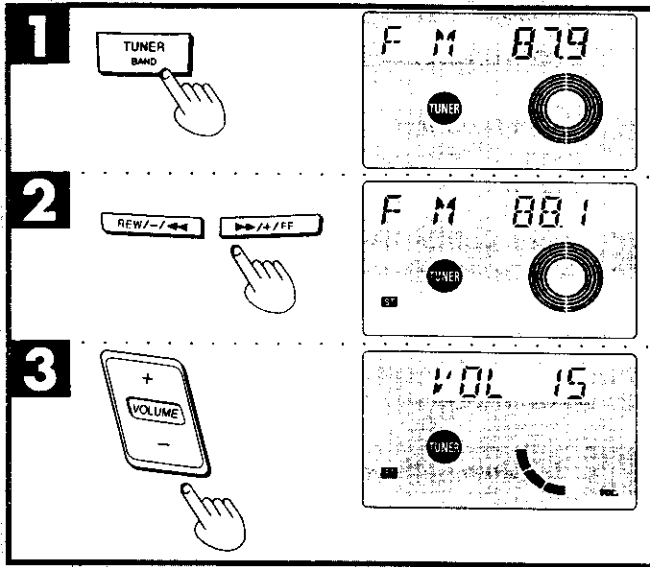
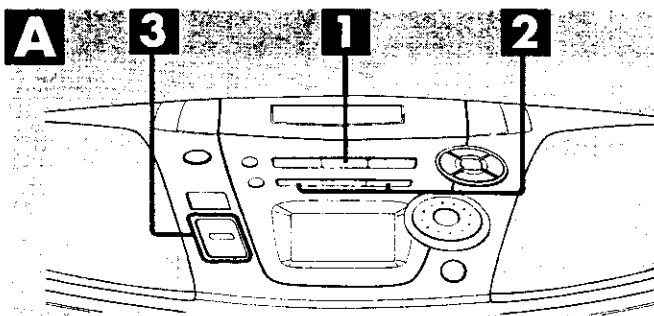

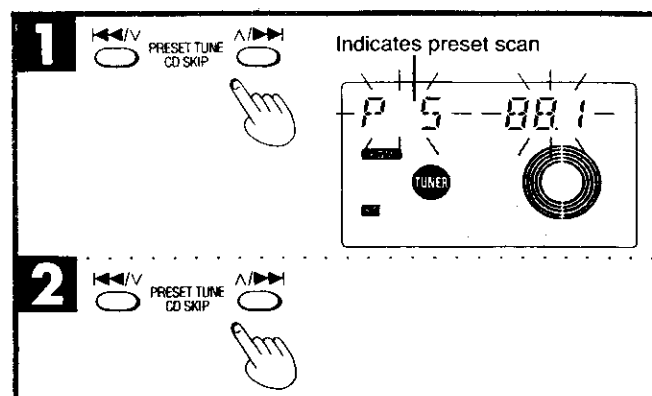
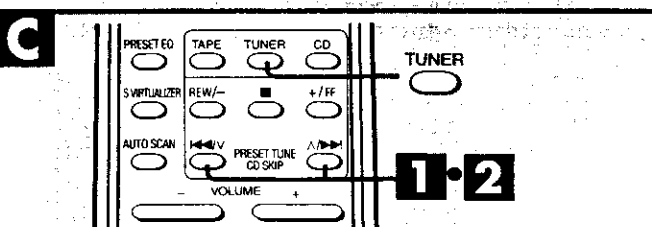
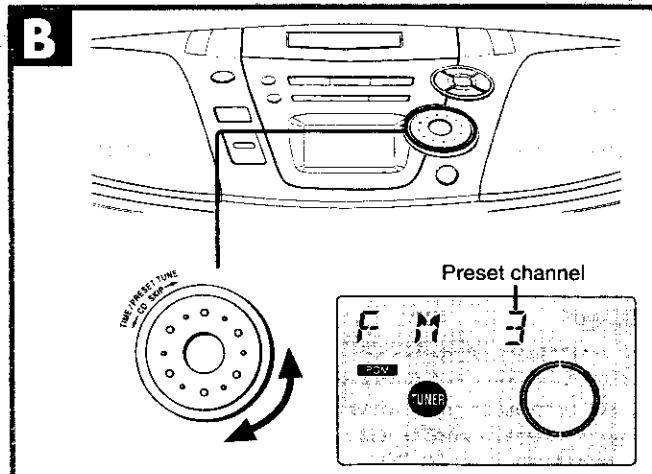
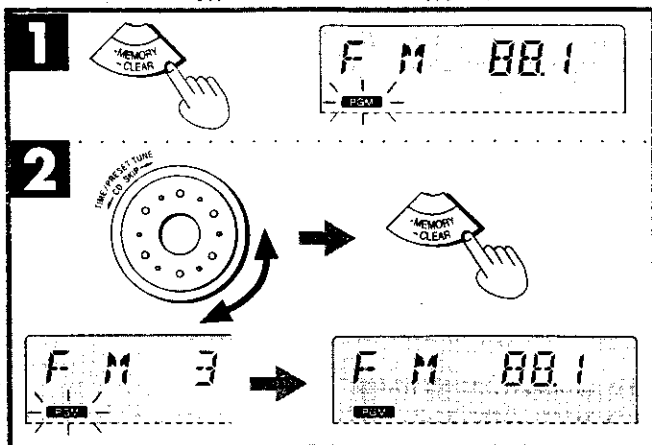
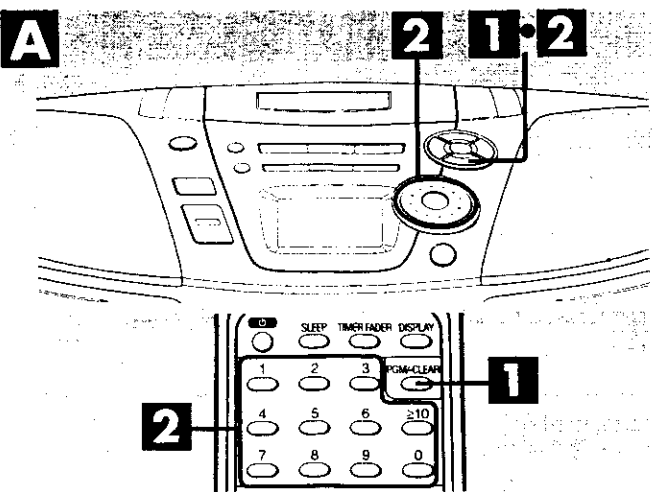

Preparation: (when using batteries) Press [POWER].

### Preset tuning

Tuning is simpler if you preset stations. You can preset 12 FM and 12 AM stations.

#### A Presetting radio stations

Preparation: Tune to the station you want to preset. (→ page 10)

1 Press [•MEMORY-CLEAR].

2 While "PGM" is flashing Turn [TIME/PRESET TUNE ← CD SKIP →] to select a channel and press [•MEMORY-CLEAR].

On the remote control

Press the numbered button(s) to enter the station into a channel (1 to 12).

To enter channel 10, 11 or 12 Press [≥10], then the two digits.

If "PGM" goes off during presetting, return to step 1.

#### Selecting channels

Preparation: Press [TUNER BAND] to select "FM" or "AM".

B Turn [TIME/PRESET TUNE ← CD SKIP →] to select the channel.

On the remote control

Press the numbered button(s) to select the channel (1 to 12).

To select channel 10, 11 or 12, press [≥10], then the two digits.

#### C Using preset scan

You can search for a station by listening to all preset channels for 8 seconds each.

Remote control only

Preparation: Press [TUNER] to select "FM" or "AM".

1 Press and hold [◀/V] or [^/▶▶] until "PS" appears on the display. Preset scan starts.

2 Press [◀/V] or [^/▶▶] when you find the desired channel.

Preset scan ends after searching through each preset channel once. To stop during the process, press [◀/V] or [^/▶▶].

#### Cancelling a preset channel

e.g. If channel 3 is not needed

① Select channel 3.

② Press [•MEMORY-CLEAR].

③ While "PGM" is flashing

Turn [TIME/PRESET TUNE ← CD SKIP →] to display "--".

④ Press [•MEMORY-CLEAR].

Now, when you perform preset scan or turn [TIME/PRESET TUNE ← CD SKIP →] to select a preset channel, channel 3 is skipped.

#### Hints

• To select the cancelled channel, press the remote control's numbered buttons.

• You can press [◀/V] or [^/▶▶] on the remote control for turning of [TIME/PRESET TUNE ← CD SKIP →] described above.

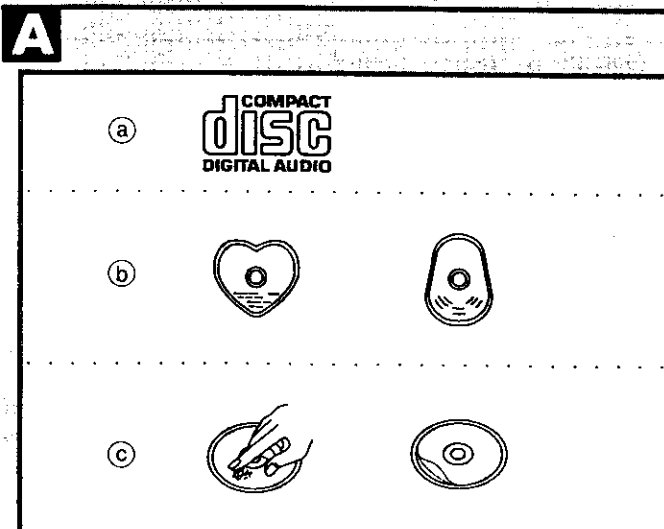
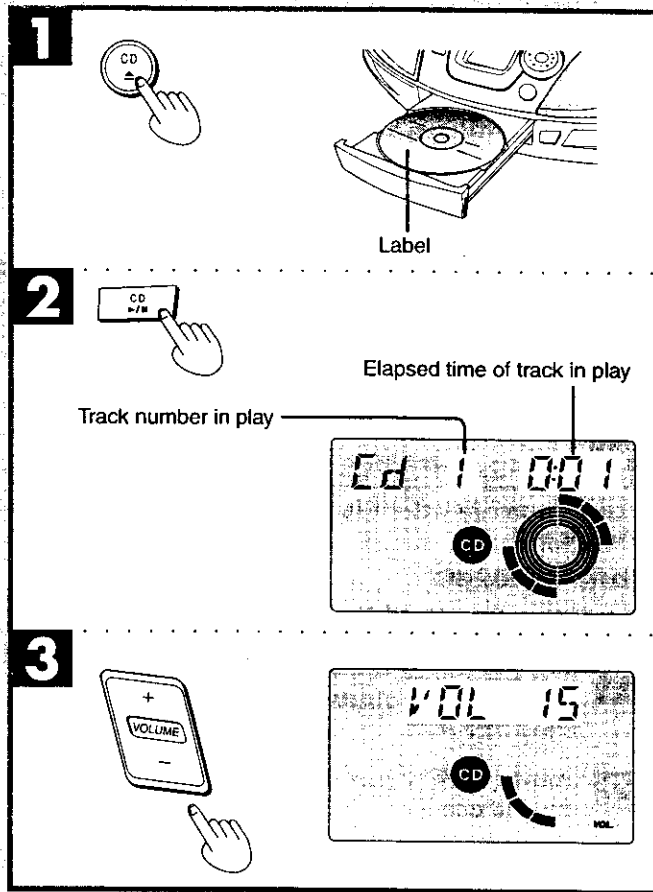
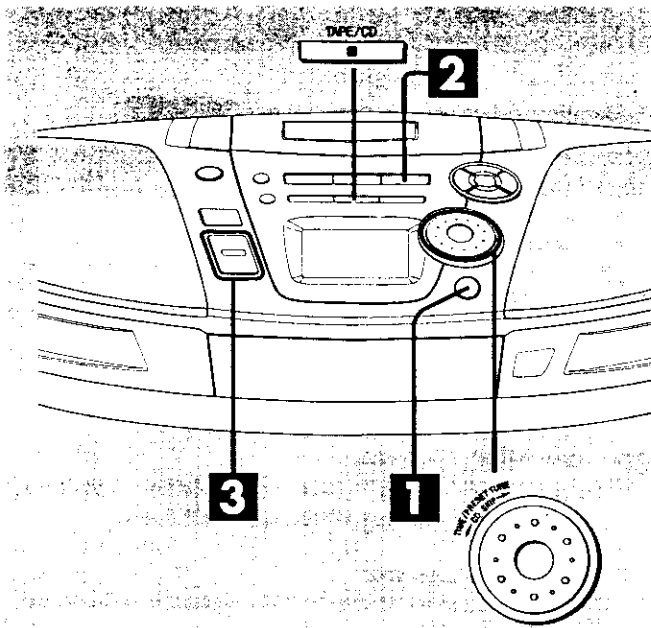

**CDs**

- 1** Press [**▲ CD**] to open the tray.  
(The unit comes on.)  
Load a CD and press [**▲ CD**] to close the tray.
- 2** Press [**▶/|| CD**] to start play.  
Plays to the end of the CD and stops.
- 3** Press [**+ , - VOLUME**] to adjust the volume.

**To stop play**

Press [**■ TAPE/CD**].

**One touch play** (When using AC power)

When a CD is loaded, press [**▶/|| CD**].  
The unit comes on and play starts.

**To pause play**

Press [**▶/|| CD**] during play.  
Press again to resume play.

**To skip tracks**

Turn [**TIME/PRESET TUNE ← CD SKIP →**] clockwise (forward) or counter-clockwise (backward).

**On the remote control**

Press [**◀◀ / √**] (backward) or [**∧ / ▶▶**] (forward).

**Searching through tracks**

Press and hold [**REW / - / ◀◀**] (backward) or [**▶▶ / + / FF**] (forward) during play.

**On the remote control**

Press and hold [**◀◀ / √**] (backward) or [**∧ / ▶▶**] (forward) during play.

**Note**

Separate this unit from radios and televisions if it causes interference.

**A CD selection**

Choose CDs with this mark: (a)

**Do not**

- use irregularly shaped CDs (b).
- use CDs with labels and stickers that are coming off or with adhesive exuding from under labels and stickers. (c)
- attach scratch-proof covers or any other kind of accessory.
- write anything on the CD.
- clean CDs with liquids. (Wipe with a soft, dry cloth.)
- use CDs printed with label printers available on the market.

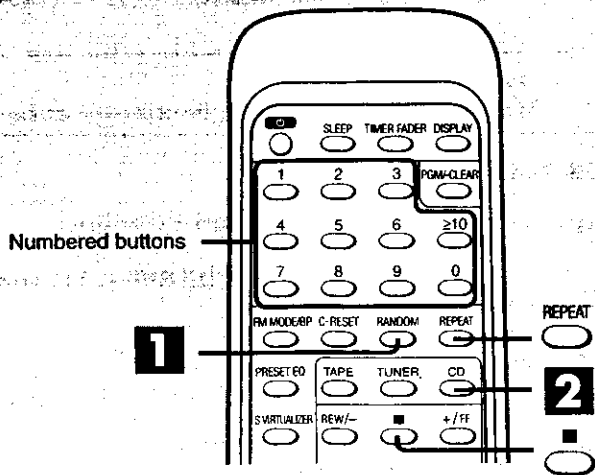

## Other modes of play

Preparation: Press [■] to switch to CD mode.

Remote control only

**A Direct access play**  
Starts play from a selected track

Select the track with the numbered buttons.  
For two-digit tracks, press [≥10], then the two digits.

**B Repeat play**  
Plays a track or all tracks repeatedly

Press [REPEAT] before or during play to select a mode.  
Each time you press the button:

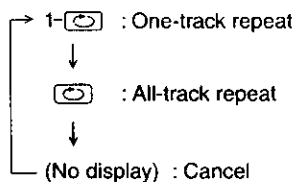

Press [CD] to start play if in the stop mode.

### To repeat selected tracks

- Start program play (⇒ page 14).
- Press [REPEAT] to select "1- [CD icon]".

### To cancel

Press [REPEAT] until "1- [CD icon]" and "[CD icon]" are cleared.  
The mode is also cancelled if the CD tray is opened.

**Random play**  
Plays the tracks once each in random order

- Press [RANDOM] during CD stop mode.
- Press [CD] to start play.

### To cancel

Press [RANDOM] to clear "[RANDOM]".  
If cancelled during play, play continues to the end of the CD.  
The mode is also cancelled if the CD tray is opened.

### Note

- Random play cannot be used together with 1-track repeat and program play.
- You cannot select tracks with the numbered buttons.
- You cannot skip to tracks already played.
- Search can be done within the track in play only.

**A**

**B**

**1**

**2**

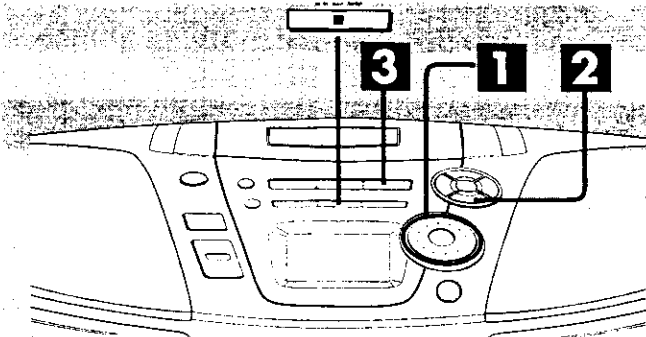

**Program play**

Select up to 36 tracks to play in the order you choose.

**On the main unit**

Preparation: Press [■ TAPE/CD] to switch to CD mode.

**1** Turn [TIME/PRESET TUNE ← CD SKIP →] to select the track.

**2** Press [•MEMORY-CLEAR].

Repeat steps **1** and **2** to program other tracks.

**3** Press [▶/|| CD] to start play.

**On the remote control**

Preparation: Press [■] to switch to CD mode.

**1** Press [PGM/-CLEAR].  
"PGM" appears on the display.

**2** Enter the track number with the numbered buttons.  
For tracks numbered 10 and over, press [≥10] then the two digits.  
Repeat this step to program other tracks.

**3** Press [CD] to start play.

The program remains intact even if play is stopped or the unit is turned off. "Cd-P" appears when play is stopped to indicate the contents are in the memory.

**To cancel**

Press and hold [•MEMORY-CLEAR] (remote control: [PGM/-CLEAR]) in the stop mode until "CLEAR" is displayed. The mode is also cancelled if the CD tray is opened.

**"FULL" is displayed**

If 36 tracks have already been programmed.

**"--:--" is displayed**

If the total play time of the program exceeds 100 minutes. You can still program and play tracks.

**A To check the program contents (while "Cd-P" is displayed)**

Turn [TIME/PRESET TUNE ← CD SKIP →].

**On the remote control**

Press [◀/V] or [^/▶▶].

Listening

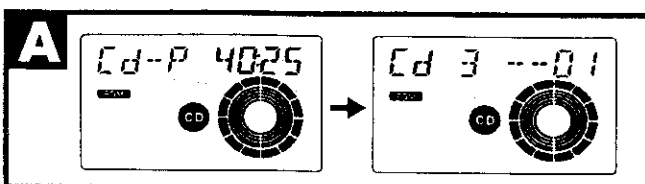
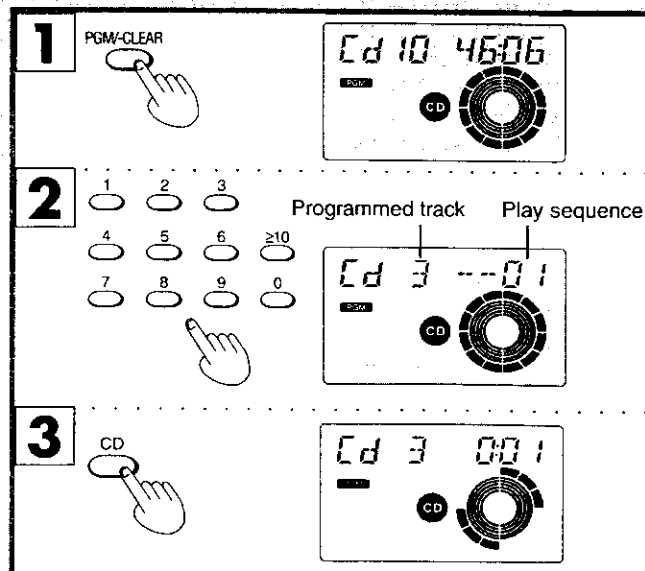
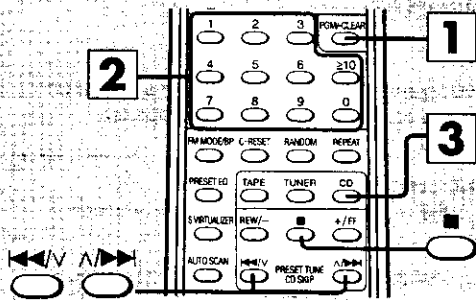
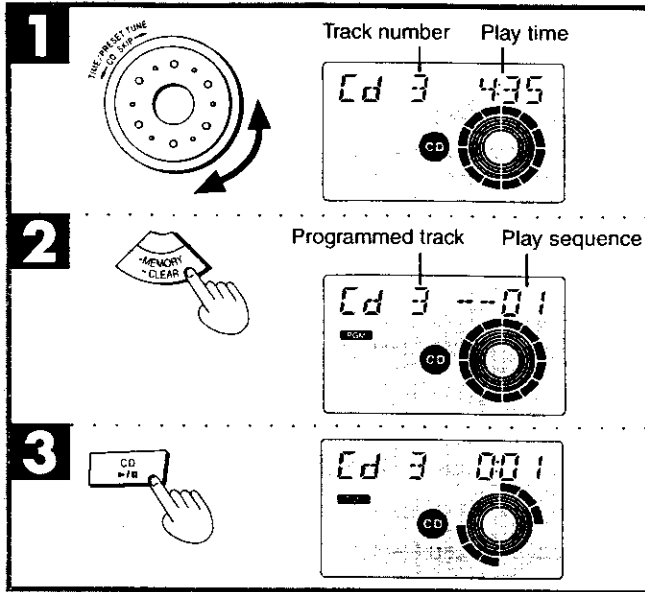

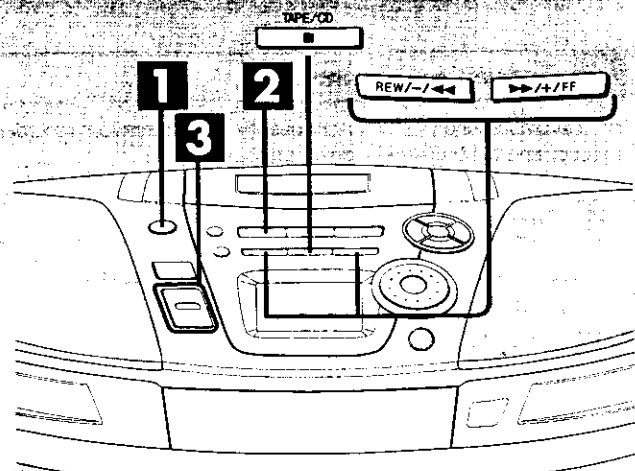

**1** Press [**▲ DECK**] to open the deck.  
(The unit comes on.)  
Load a cassette and close the deck by hand.

**2** Press [**▶ TAPE**] to start play.

**3** Press [**+ , - VOLUME**] to adjust the volume.

**To stop play**

Press [**■ TAPE/CD**].

**One touch play** (When using AC power)

When a cassette is loaded, press [**▶ TAPE**].

The unit comes on and play starts.

**Fast-forward and rewind**

Press [**REW / - / ◀**] (rewind) or [**▶▶ / + / FF**] (fast-forward).

**On the remote control**

Press [**REW / -**] (rewind) or [**+ / FF**] (fast-forward).

**Selection of tapes**

Use normal position tapes to play correctly.

High position and metal position tapes can be played, but the unit will not be able to do full justice to the characteristics of these tapes.

**Cassette tape care**

- Tapes exceeding 100 minutes are thin and can break or get caught in the mechanism.
- Tape slack can get caught up in the mechanism and should be taken up before the tape is played.
- Endless tapes can get caught up in the deck's moving parts if used incorrectly.

**Tips on Recording**

Use household AC power or new batteries when recording to avoid poor recordings caused by the batteries running down.

Televisions can cause interference to recordings made on this unit if the two are too close to each other.

**Selection of tapes for recording**

Use normal position tapes.

High position and metal position tapes can be used, but the unit will not be able to record or erase them correctly.

**Volume and sound quality in recording**

- Recording level is set automatically.
- Recording are unaffected by changes to sound quality.

**A To display the tape counter while recording**

**Remote control only**

Press [**DISPLAY**].

Each time you press the button in the CD or radio mode:



**To reset the tape counter**

Press [**C-RESET**].

The counter resets to "000".

**1** Side to be played back facing up

Insert the cassette with the exposed tape facing you.

**2**

**3**

**A**

DISPLAY

C-RESET

(a) Cd 3 105

(b) PM 4:20

(c) Cd 154

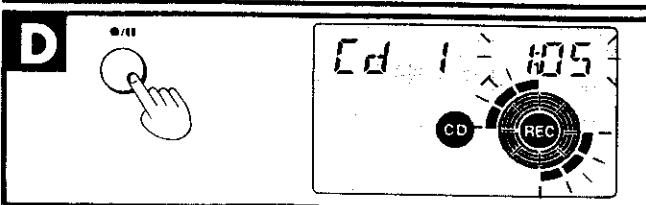
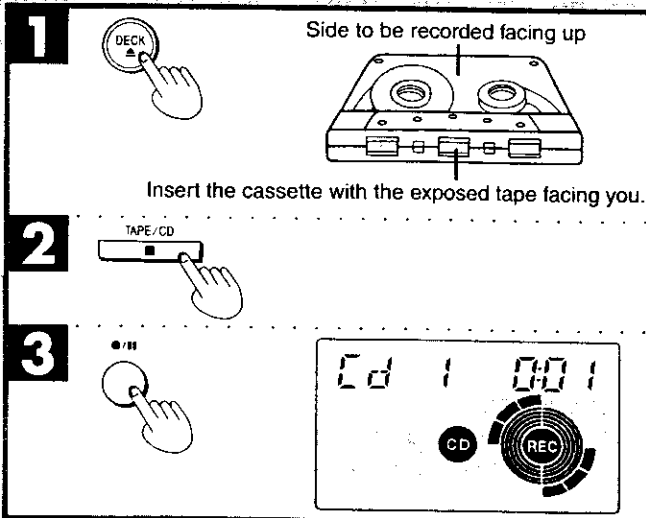
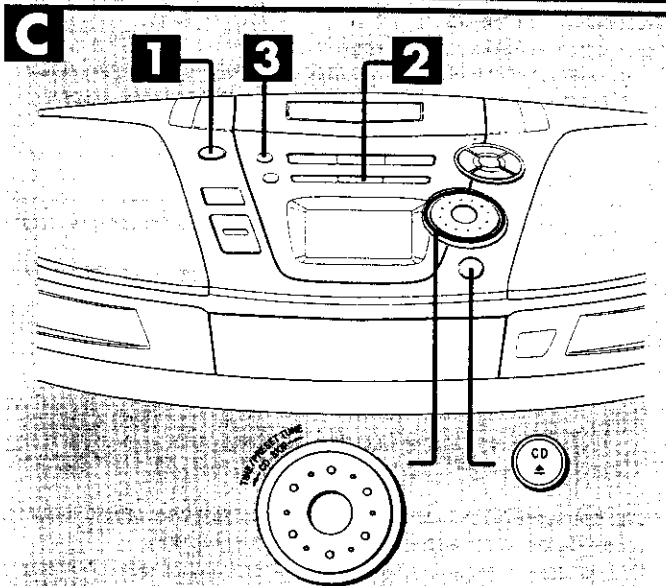
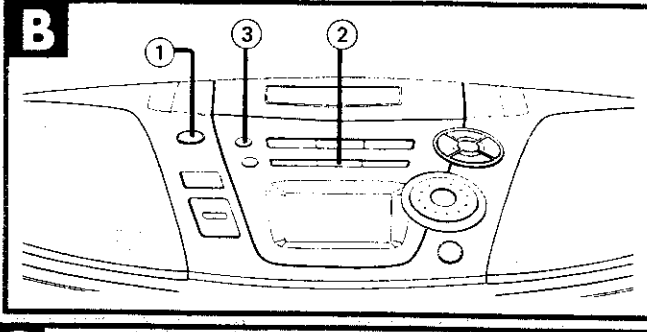
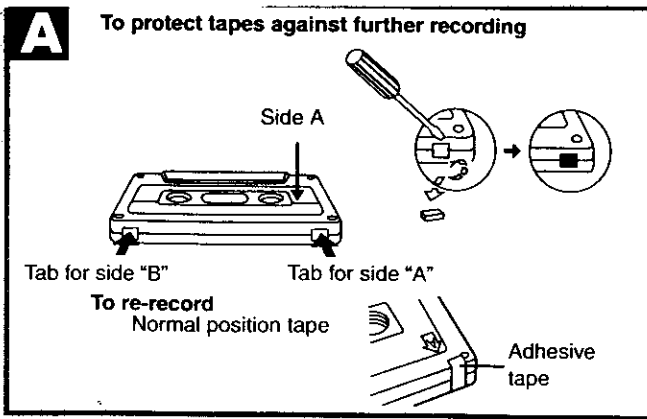

## Tips on Recording

### A Erasure prevention

The illustration shows how to remove the tabs to prevent recording. To record on the tape again, cover as shown.

### B Erasing recordings

- ① Insert the cassette with the side to be erased facing up.
- ② Press [■ TAPE/CD] to switch to TAPE mode.
- ③ Press [●/II].

## Recording CDs

### C Normal recording

#### Preparations:

- Insert a CD (⇒ page 12).
- Wind on the leader tape.

- 1** Press [▲ DECK] to open the deck.  
Load a cassette with the side for recording facing up and close the deck by hand.
- 2** Press [■ TAPE/CD] to switch to CD mode.  
Each time you press the button:  
TAPE ↔ Cd
- 3** Press [●/II] to start recording.  
CD play and recording start at the same time.  
The cassette stops when the CD finishes.

**To stop recording**  
Press [■ TAPE/CD].

**D To pause recording**  
Press [●/II].  
Press again to resume recording.

**To continue recording from another CD on the same cassette**

- ① Press [▲ CD] and replace the CD.
- ② Press [●/II].

#### To record selected tracks

- ① Do step **1**, then program the tracks (⇒ page 14).
- ② Press [●/II].

#### To skip unwanted tracks

- ① Press [●/II] to pause recording (the CD also pauses).
- ② Turn [TIME/PRESETTUNE ← CD SKIP →] so the next track you want to record is displayed.
- ③ Press [●/II] to resume recording.



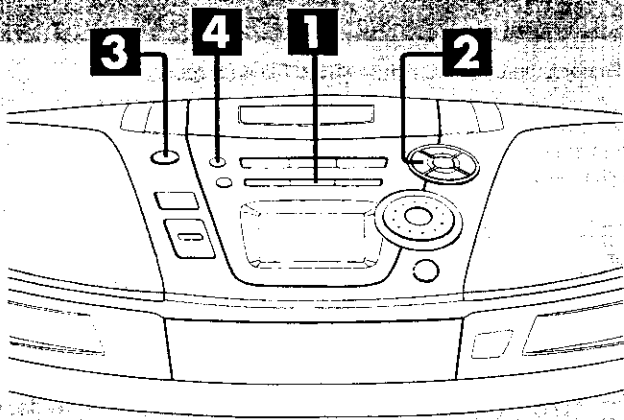

**ALL-REC**

Records the whole CD or selected tracks. When the tape finishes before CD, recording and CD pauses for you to resume recording on the opposite side.

**Preparation:** Insert a CD (⇒ page 12).

**1** Press [■ TAPE/CD] to switch to CD mode.

**2** Press [CD REC MODE] to display "ALL-REC".  
Each time you press the button:

ALL-REC → 1-REC → OFF

The display shows the tape length needed.  
"C ---" indicates the tape needed exceeds 100 minutes.  
You can still record, but some tracks may not be recorded if the tape isn't long enough.

**3** Load a cassette with the side for recording facing up.

**4** Press [●/||] to start recording.  
The unit rewinds the tape, records 10 seconds of silence, and then starts recording.

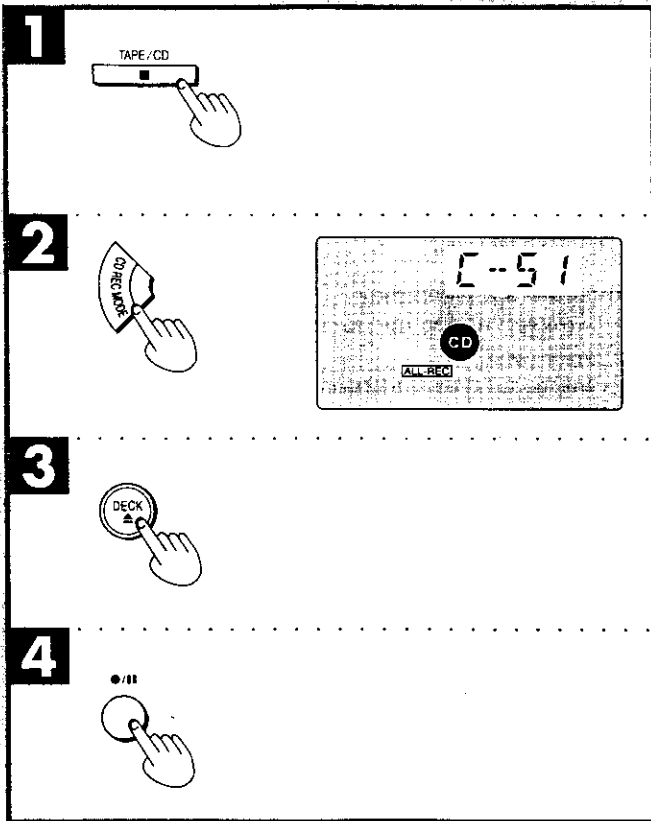

**To stop recording**

Press [■ TAPE/CD]. The CD also stops.

**If a track is interrupted at the end of the side facing up**  
Recording and CD pauses.

To record the track again on the opposite side

1. Press [▲ DECK], flip the cassette, and insert it.
2. Press [●/||].

The unit records 10 seconds of silence, and resumes recording from the beginning of the cut-off track.

**To record selected tracks**

- ① Program tracks (⇒ page 14).
- ② Do steps **2** to **4**.

**Note**

You cannot use ALL-REC with random play and repeat play (⇒ page 13).

## Recording CDs

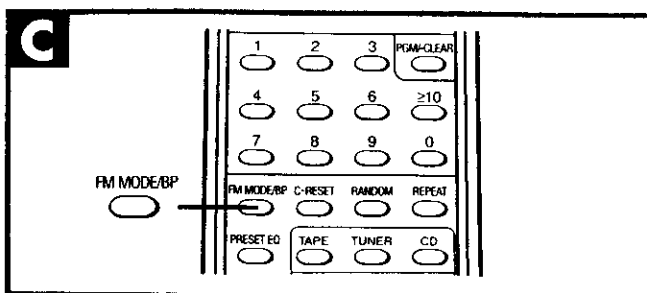
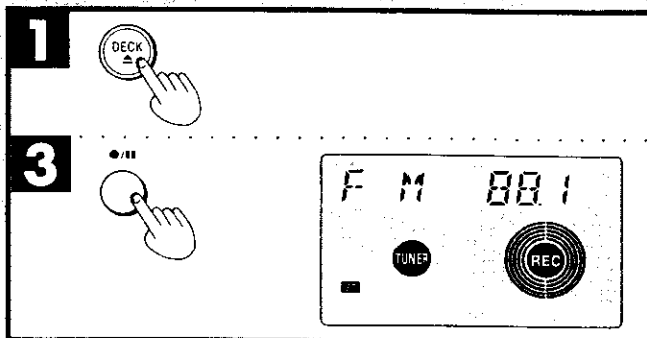
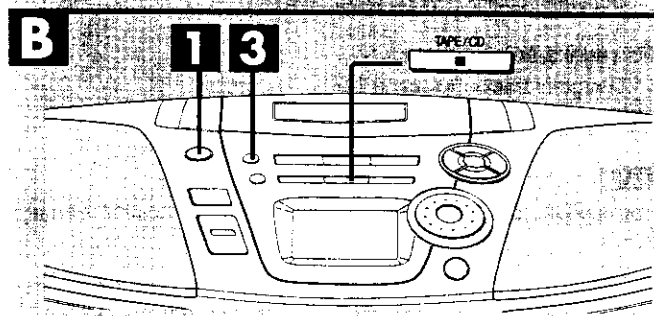
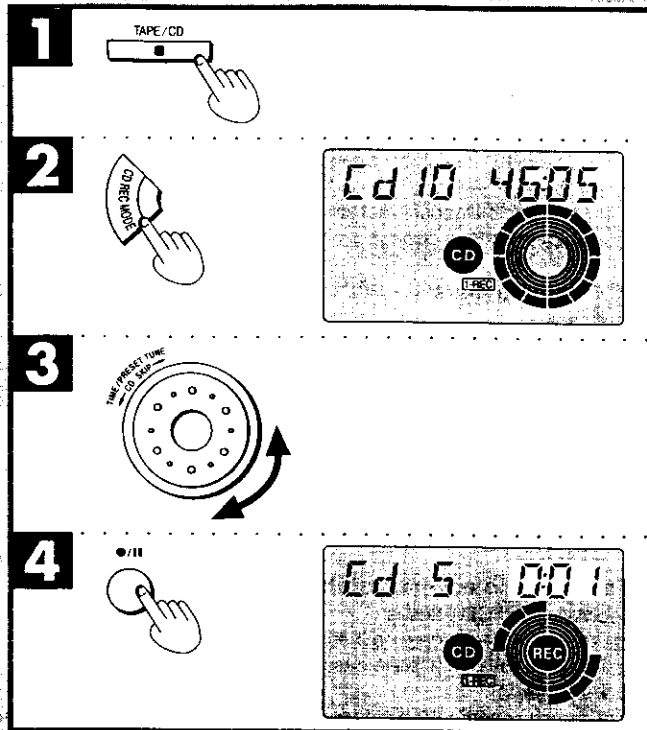
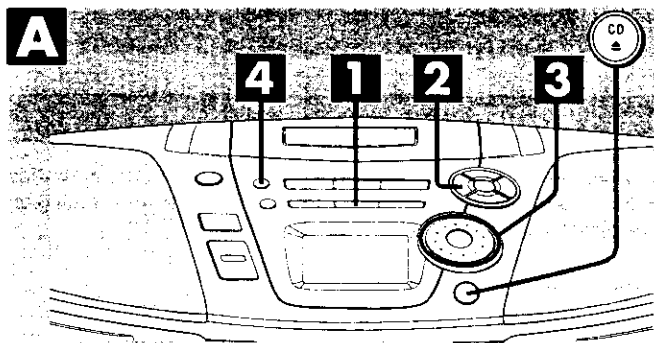

### A 1-REC

Records a selected track from the CD and stops.

#### Preparations:

Insert a CD (⇒ page 12) and a cassette (⇒ page 15).  
Wind the tape on to where you want to start recording.

- 1** Press [■ TAPE/CD] to switch to CD mode.
- 2** Press [CD REC MODE] to display "1-REC".  
Each time you press the button:  
ALL-REC → 1-REC → OFF
- 3** Turn [TIME/PRESET TUNE ← CD SKIP →] to select the track you want to record.
- 4** Press [●/II] to start recording.  
CD play and recording start at the same time.

#### To stop recording

Press [■ TAPE/CD]. The CD also stops.

#### To continue recording from another CD

1. Press [▲ CD] and replace the CD.
2. Do steps **3** to **4**.

#### To record a track in play

- ① Press [CD REC MODE] to display "1-REC".
- ② Press [●/II].

Recording starts from the beginning of the track and stops when the track finishes.

#### Note

Recording and CD will stop when the tape reaches its end, even if the track has not finished.

## B Recording the Radio

#### Preparations:

- To record from the beginning of the tape:  
Wind on the leader tape.
- To record from part way through the tape:  
Wind the tape on to where you want to start recording.

- 1** Load a cassette with the side for recording facing up.
- 2** Tune to the station (⇒ page 10).
- 3** Press [●/II] to start recording.

#### To stop recording

Press [■ TAPE/CD].

#### To pause recording

Press [●/II].  
Press again to resume recording.

### C Reducing noise when recording AM (Beat Proof function)

#### Remote control only

Press [FM MODE/BP] while recording.  
Each time you press the button:  
bP1 ↔ bP2  
Choose the setting with the least noise.

## A Sound Quality

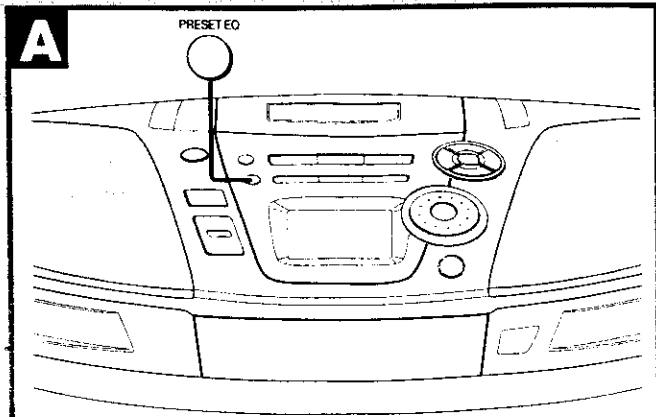

You can choose one of four types of sound quality.

- Ⓐ XBS: Adds punch to rock
- Ⓑ Clear: Clarifies higher sounds
- Ⓒ Soft: For background music
- Ⓓ Vocal: Adds gloss to vocals

Press [PRESET EQ] to select a setting.

Each time you press the button:

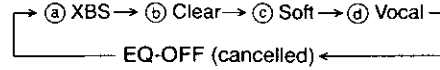

### Note

Changes to sound quality do not affect recordings.

## B 3-D sound with the Sound Virtualizer

Remote control only

You can create a three-dimensional sound field when listening to stereo sound.

Press [S.VIRTUALIZER].

Press again to cancel.

### Note

- This feature does not affect recordings.
- The actual effect depends on the source played.

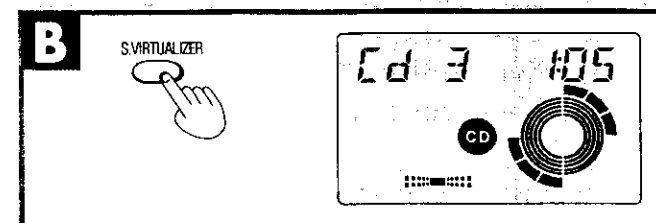
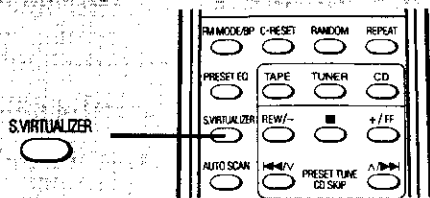
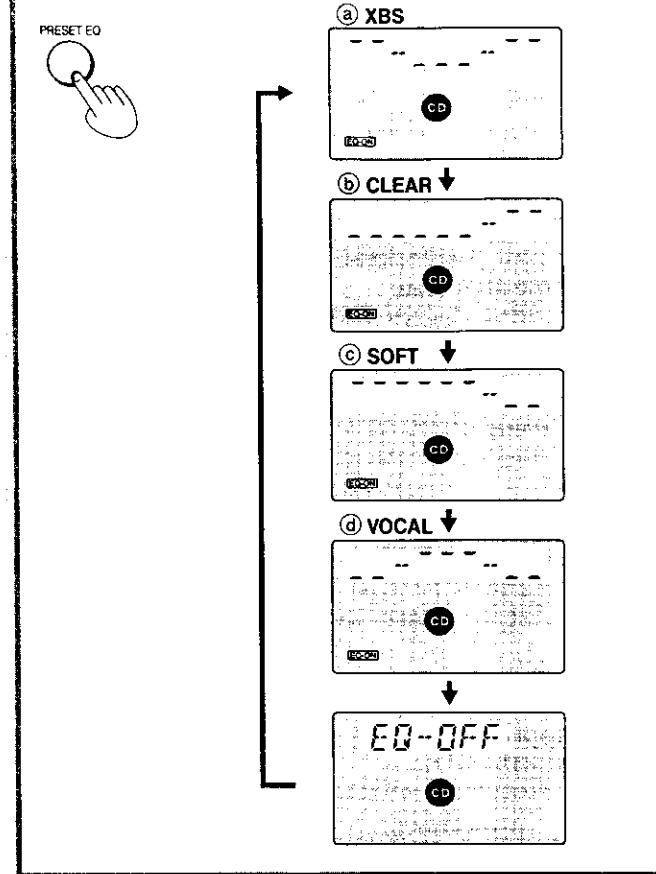

## The Play and Record Timer

You can set the timer to come on at a certain time to wake you up (play timer) or to record a radio station (record timer).

### Preparations:

Turn the unit on and set the clock. (→ page 9)

- For **play timer**, prepare the music source (tape/CD/radio) for listening, and set the volume.
- For **record timer**, check the cassette's erasure prevention tab (→ page 16: ) and load the cassette with the side for recording facing up. Tune to the radio station (→ page 10 to 11), and set the volume.

### Setting the start and finish times

- 1 Press [CLOCK/TIMER] to select the desired timer function.

Each time you press the button:

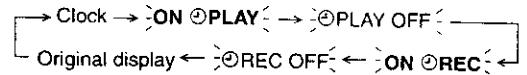

ON : to set the play timer

ON : to set the record timer

Proceed to step 2 before these indicators stop flashing (about 10 seconds).

- 2 ① Turn [TIME/PRESET TUNE ← CD SKIP →] to set the start time.  
② Press [CLOCK/TIMER].

- 3 ① Turn [TIME/PRESET TUNE ← CD SKIP →] to set the finish time.  
② Press [CLOCK/TIMER].

The start and finish times are now set.

### Turning the timer on

- 4 Press [] to display the timer indicator.

Each time you press the button:

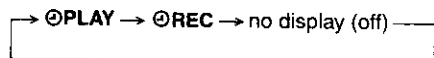

: to turn the play timer on

: to turn the record timer on

(The indicator doesn't appear if the start and finish times haven't been set.)

"E" appears if the clock hasn't been set.

- 5 Press [POWER ] to turn the unit off.

The unit must be off for timer to operate.

The record timer comes on about 30 seconds earlier than the set time.

### To cancel the timer

Press [] when the unit is on to clear the timer indicators from the display.

(The timer comes on at the set time everyday if the timer is on.)

### To check the settings (when unit is off)

Press [CLOCK/TIMER].

The settings are shown in the following order:

Start time, Finish time → Music source → Volume → Original display

### To change the settings (when unit is on)

#### To change the times

Do steps 1, 2, 3, and 5.

#### To change the source or volume

1. Press [] to clear the timer indicator.
2. Make changes to the source or volume.
3. Do steps 4 to 5.

You can enjoy your desired source after you have set the timer. Turn the unit off before the timer's start time.

### Note

The play and record timers cannot be used together.

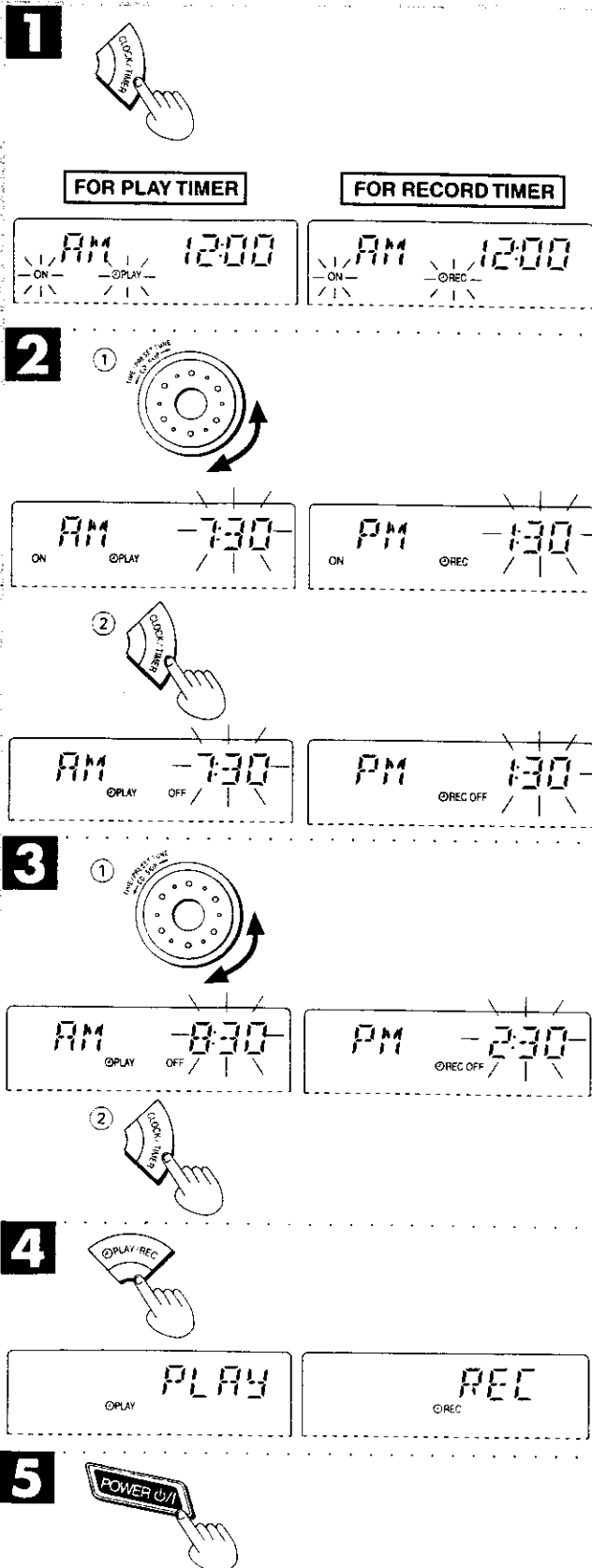
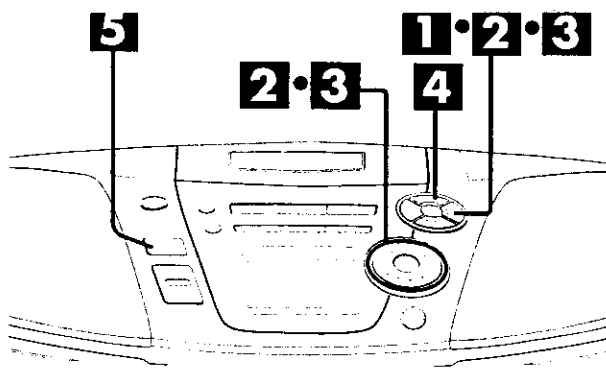

## A The Sleep Timer

### Remote control only

You can set the unit to turn off after certain time. (e.g. when you want to fall asleep while listening to music.)

### Press [SLEEP] to select the time (minutes).

Each time you press the button:

→ SLEEP 30 → SLEEP 60 → SLEEP 90 → SLEEP 120

← SLEEP OFF ←

### To cancel

Press [SLEEP] to select "SLEEP OFF".

### To check the remaining time

Press [SLEEP] once.

The remaining time is shown for about 5 seconds.

### To change the setting

Press [SLEEP] to select the new time.

### Note

You can use sleep timer in combination with play and record timer. Make sure the unit is off before the play/record timer's start time.

## B The Timer Fader

### Remote control only

Volume increases slowly to the set level when a timer turns the unit on and decreases slowly when the sleep timer turns the unit off.

### Press [TIMER FADER] to display "FADER".

(All timers will be affected.)

Press again to cancel.

### Note

This feature does not affect record timer's recordings.

## Maintenance

### If the surfaces are dirty

To clean this unit, wipe with a soft, dry cloth.

If the surfaces are extremely dirty, use a soft cloth dipped in a soap-and-water solution or a weak detergent solution.

- Never use alcohol, paint thinner, or benzine to clean this unit.
- Before using chemically treated cloth, read the instructions that came with the cloth carefully.

### For a cleaner crisper sound

Clean the heads after every 10 hours of use to assure good quality playback and recording.

Use a cleaning tape (not included).

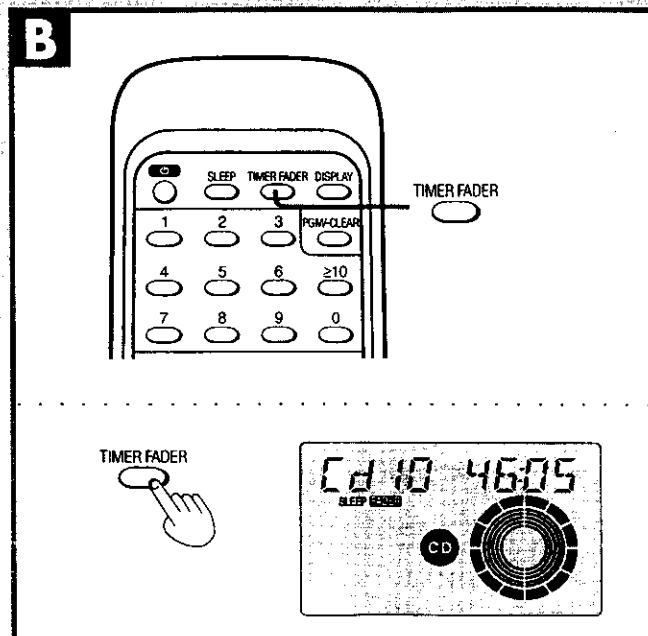
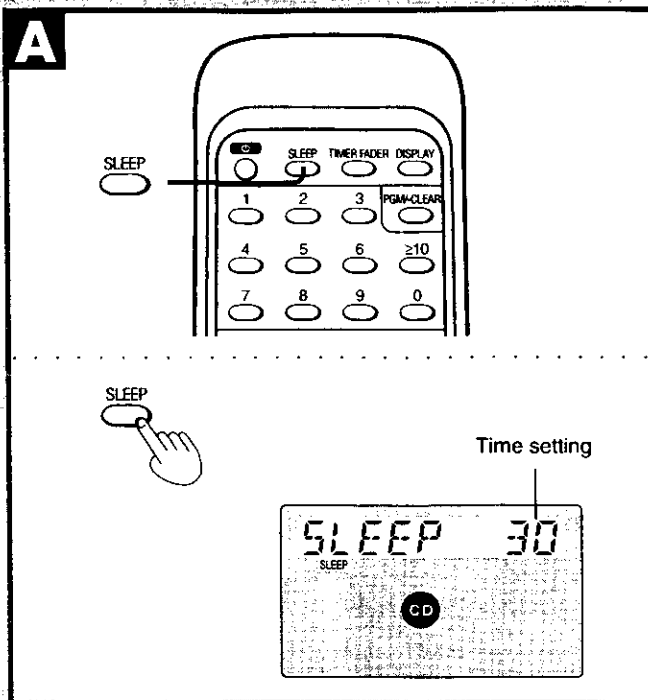

# Troubleshooting

Before requesting service, check the points below. If you can't fix the unit as described below, or if something not listed here occurs, refer to the enclosed directory to locate an Authorized Service Center convenient to you or contact your dealer.

**For detailed instructions, contact an authorized servicenter in the U.S.A. and Panasonic Canada Inc. Customer Care Centre in Canada.**

**In the U.S.A. 1-800-211-7262 or web site (<http://www.panasonic.com>)**

**In Canada 905-624-5505 or web site ([www.panasonic.ca](http://www.panasonic.ca))**

Reference pages are shown as black circled numbers (e.g. ⑤)

## Common problems

<p>"E" is displayed          "UO1" is displayed          "UO2" is displayed</p>	<p>Indicates incorrect operation. Read the instructions.          Replace the batteries or use household AC power. ⑥          Power batteries haven't been inserted. Insert them or use household AC power. ("UO2" appears only if you have inserted memory batteries.) ⑥</p>
---	---

## CD

<p>CD won't play or CD display is incorrect          Certain sections are not played properly</p>	<p>Place the CD label facing up. ⑫          Wait for an hour for condensation to dry and try again.          Clean the CD. ⑫          Replace the CD if it is scratched, warped, or non-standard.</p>
---	---

## Cassette deck

<p>Recording is not possible          Poor sound quality</p>	<p>If the cassette's tabs have removed, cover the holes with adhesive tape. ⑯          Clean the heads. ⑳</p>
--	---

## Radio

<p>A lot of noise or difficult to tune</p>	<p>Interference may be caused by other equipment or the use of its remote control. Turn the other equipment off or separate this unit from them.</p>
--	--

## Remote control

<p>The remote control doesn't work.          The unit can't be turned on from the remote control.</p>	<p>Check the batteries are inserted correctly. ⑧          Replace the batteries if they are worn. ⑧          Turn the unit on from the main unit if you are using batteries to power the unit. ⑥ ⑧</p>
---	--

# Product Service

Do not attempt to remove the cover(s) or repair the unit yourself. Refer servicing to qualified personnel only.

## Product information

For product service, product information or assistance with product operation, refer to the servicenter directory.

ONLY FOR U.S.A.

# Panasonic

# Technics

# Quasar

**For Product Information, Operating Assistance, Literature Request, Dealer Locations, and all Customer Service inquiries please contact:  
1-800-211-PANA (7262), Monday-Friday 9 am-9 pm; Saturday-Sunday 9 am-7 pm, EST.**

**Web Site: <http://www.panasonic.com>  
You can purchase parts, accessories or locate your nearest servicenter by visiting our Web Site.**

### Accessory Purchases:

**1-800-332-5368 (Customer Orders Only)  
Panasonic Services Company 20421 84th Avenue South, Kent, WA 98032  
(6 am to 5 pm Monday-Friday; 6 am to 10:30 am Saturday; PST)  
(Visa, MasterCard, Discover Card, American Express, Check)**

### Factory Servicenters Locations

#### CALIFORNIA

6550 Katella Avenue  
Cypress, CA 90630

800 Dubuque Avenue  
S. San Francisco  
CA 94080

20201 Sherman Way  
Suite 102  
Canoga Park, CA 91306

3878 Ruffin Road  
Suite A  
San Diego, CA 92123

#### COLORADO

1640 South Abilene Street  
Suite D  
Aurora, CO 80012

#### FLORIDA

3700 North 29<sup>th</sup> Avenue  
Suite 102  
Hollywood, FL 33020

#### GEORGIA

8655 Roswell Road  
Suite 100  
Atlanta, GA 30350

#### ILLINOIS

9060 Golf Road  
Niles, IL 60714

1703 North Randall Road  
Elgin, IL 60123  
(Pick-up/Drop-off only)

#### MARYLAND

62 Mountain Road  
Glen Burnie, MD 21061

#### MASSACHUSETTS

60 Glacier Drive  
Suite G  
Westwood, MA 02090

#### MICHIGAN

37048 Van Dyke Avenue  
Sterling Heights, MI 48312

#### MINNESOTA

7850-12<sup>th</sup> Avenue South  
Airport Business Center  
Bloomington, MN 55425

#### OHIO

2236 Waycross Road  
Civic Center Plaza  
Forest Park, OH 45240

#### PENNSYLVANIA

2221 Cabot Blvd. West  
Suite B  
Langhorne, PA 19047

Chartiers Valley  
Shopping Center

1025 Washington Pike  
Bridgeville, PA 15017

#### TENNESSEE

3800 Ezell Road  
Suite 806  
Nashville, TN 37211

#### TEXAS

7482 Harwin Drive  
Houston, TX 77036

13615 Welch Road  
Suite 101  
Farmers Branch  
TX 75244

#### WASHINGTON

20425-84<sup>th</sup> Avenue South  
Kent, WA 98032

#### HAWAII

99-859 Iwaiwa Street  
Aiea, Hawaii 96701  
Phone (808) 488-1996  
Fax (808) 486-4369

### Service in Puerto Rico

**Matsushita Electric of Puerto Rico, Inc. Panasonic Sales Company/Factory Servicenter:  
Ave. 65 de Infanteria, Km. 9.5, San Gabriel Industrial Park, Carolina, Puerto Rico 00985  
Phone (787) 750-4300 Fax (787) 768-2910**

Reference

# Specifications

## Radio

### Frequency range

FM	87.9–107.9 MHz (200 kHz steps)
	87.5–108.0 MHz (100 kHz steps)
AM	520–1710 kHz (10 kHz steps)

## CD player

Sampling frequency	44.1 kHz
Decoding	16 bit linear
Beam source	Semiconductor laser (wavelength 780 nm)
No. of channels	2 channel, stereo
Wow and flutter	Below measurable limit
D/A converter	MASH (1 bit DAC)

## Tape recorder

Track system	4 track, 2 channel, stereo
Monitor system	Variable sound monitor
Recording system	AC bias
Erasing system	Multi Pole magnet
Frequency range	
Normal position	50–14000 Hz

## General

Speakers	8 cm 5.4 $\Omega$ x 2
Jacks	
Output	PHONES: 3.5 mm stereo (16–32 $\Omega$ )
Power requirement	
AC	120 V, 60 Hz
	Power consumption: (RX-ES25) 32 W
	(RX-ES20) 16 W
Battery	12 V [Eight R20/LR20 (D, UM-1) batteries]
	•Do not use rechargeable type batteries.

## Memory back-up for computer/clock

	6 V [Four R6/LR6 (AA, UM-3) batteries]
	•Do not use rechargeable type batteries.

## Dimensions (WxHxD)

	529 x 144 x 276 mm
	(20 <sup>13/16</sup> " x 5 <sup>11/32</sup> " x 10 <sup>7/8</sup> " )

## Weight

(RX-ES25)	4.5 kg (9 lb. 15 oz.) without batteries
(RX-ES20)	3.5 kg (7 lb. 11 oz.) without batteries

Power consumption in standby mode: 3.1 W (RX-ES25) 2.1 W (RX-ES20)
---

### Note

Specifications are subject to change without notice.  
Weight and dimensions are approximate.

Panasonic Consumer Electronics  
Company, Division of Matsushita  
Electric Corporation of America  
One Panasonic Way Secaucus,  
New Jersey 07094  
<http://www.panasonic.com>

Panasonic Sales Company,  
Division of Matsushita Electric of  
Puerto Rico, Inc. ("PSC")  
Ave. 65 de Infantería, Km. 9.5  
San Gabriel Industrial Park, Carolina,  
Puerto Rico 00985

Panasonic Canada Inc.  
5770 Ambler Drive  
Mississauga, Ontario  
L4W 2T3  
[www.panasonic.ca](http://www.panasonic.ca)

En