

Things You Should Know

Thank you for choosing Panasonic!

You have purchased one of the most sophisticated and reliable products on the market today. Used properly, we're sure it will bring you and your family years of enjoyment. Please take time to fill in the information below. The serial number is on the tag located on the underside of your Palmcorder. Be sure to **retain this manual** as your convenient Palmcorder information source.

Date of Purchase
Dealer Purchased From
Dealer Address
Dealer Phone No.
Model No.
Serial No.

Unpack your Camcorder

1 pc. AC Adaptor
(PV-DAC9)
with AC Cable, DC Cable
and Jack Box

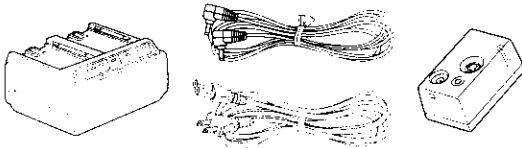

1 pc. Battery Pack
(PV-DBP8)

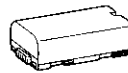

1 pc. AV Cable
(VJAW0043)

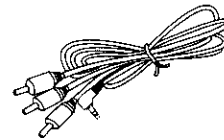

1 pc. Lens Cap
(LSYF0358)



1 pc. Shoulder Strap
(VYCW0225)





Things You Should Know

Safety Precautions

WARNING: TO PREVENT FIRE OR SHOCK HAZARD, DO NOT EXPOSE THIS EQUIPMENT TO RAIN OR MOISTURE.

Your Mini DV Palmcorder is designed to record and play back in Standard Play (SP) mode only.

This Palmcorder is equipped with the HQ System to provide excellent video pictures. It is recommended that only cassette tapes that have been tested and inspected for use in VCR machines with the Mini DV mark be used.

 CAUTION RISK OF ELECTRIC SHOCK DO NOT OPEN		This symbol warns the user that uninsulated voltage within the unit may have sufficient magnitude to cause electric shock. Therefore, it is dangerous to make any kind of contact with any inside part of this unit.
CAUTION: TO REDUCE THE RISK OF ELECTRIC SHOCK, DO NOT REMOVE COVER (OR BACK) NO USER-SERVICEABLE PARTS INSIDE REFER SERVICING TO QUALIFIED SERVICE PERSONNEL		This symbol alerts the user that important literature concerning the operation and maintenance of this unit has been included. Therefore, it should be read carefully in order to avoid any problems.

The above markings are located on the appliance bottom cover.

This device complies with Part 15 of the FCC Rules. Operation is subject to the following two conditions: (1) This device may not cause harmful interference, and (2) this device must accept any interference received, including interference that may cause undesired operation.

Note: This equipment has been tested and found to comply with Part 15 and part 18 of the FCC Rules. These limits are designed to provide reasonable protection against harmful interference when operated in a residential environment.

If this equipment does cause interference to radio or television reception, which can be determined by turning the equipment off and on, use the equipment in another location and/or utilize an electrical outlet different from that used by the receiver.

If necessary, consult the dealer or an experienced radio/TV technician for help. You may find the booklet, 'Something About Interference' available from FCC local regional offices helpful.

FCC Warning: To assure continued FCC compliance, use only the shielded interface cable with ferrite cores provided with Adaptec products, use only the shielded interface cable with Radius products when connecting digital video camera and computer.
Also, any unauthorized changes or modifications to this equipment would void the user's authority to operate.

Important Safeguards

1. **Read Instructions** — All the safety and operating instructions should be read before the unit is operated.
2. **Retain Instructions** — The safety and operating instructions should be retained for future reference.
3. **Heed Warnings** — All warnings on the unit and in the operating instructions should be adhered to.
4. **Follow Instructions** — All operating and maintenance instructions should be followed.
5. **Cleaning** — Unplug this video unit from the wall outlet before cleaning. Do not use liquid or aerosol cleaners. Use a dry cloth for cleaning.
6. **Attachments** — Do not use attachments not recommended by the video product manufacturer as they may be hazardous.
7. **Water and Moisture** — Do not use this video unit near water — for example near a bath tub, wash bowl, kitchen sink, or laundry tub, in a wet basement, or near a swimming pool, and the like.
8. **Accessories** — Do not place this video unit on an unstable cart, stand, tripod, bracket, or table. The video unit may fall, causing serious injury to a child or adult, and serious damage to the unit. Use only with a cart, stand, tripod, bracket, or table recommended by the manufacturer, or sold with the video unit. Any mounting of the unit should follow the manufacturer's instructions and should use a mounting accessory recommended by the manufacturer. An appliance and cart combination should be moved with care. Quick stops, excessive force, and uneven surfaces may cause the appliance and cart combination to overturn.
9. **Ventilation** — Slots and openings in the cabinet are provided for ventilation and to ensure reliable operation of the video unit and to protect it from overheating. These openings must not be blocked or covered. Never place the video unit on a bed, sofa, rug, or other similar surface, or near or over a radiator or heat register. This video unit should not be placed in a built-in installation such as a bookcase or rack unless proper ventilation is provided or the manufacturer's instructions have been adhered to.
10. **Power Sources** — This video unit should be operated only from the type of power source indicated on the marking label. If you are not sure of the type of power supply to your home, consult your appliance dealer or local power company. For video units intended to be operated from battery power, or other sources, refer to the operating instructions.



11. **Grounding or Polarization** — This video unit may be equipped with either a polarized 2-wire AC (Alternating Current) line plug (a plug having one blade wider than the other) or 3-wire grounding type plug, a plug having a third (grounding) pin.
The 2-wire polarized plug will fit into the power outlet only one way. This is a safety feature. If you are unable to insert the plug fully into the outlet, try reversing the plug. If the plug still fails to fit, contact your electrician to replace your obsolete outlet. Do not defeat the safety purpose of the polarized plug.
The 3-wire grounding type plug will fit into a grounding type power outlet. This is a safety feature. If you are unable to insert the plug into the outlet, contact your electrician to replace your obsolete outlet. Do not defeat the safety purpose of the grounding type plug.
12. **Power-Cord Protection** — Power-supply cords should be routed so that they are not likely to be walked on or pinched by items placed upon or against them, paying particular attention to cords of plugs, convenience receptacles, and the point where they exit from the unit.
13. **Outdoor Antenna Grounding** — If an outside antenna or cable system is connected to the video unit, be sure the antenna or cable system is grounded so as to provide some protection against voltage surges and built-up static charges. Part 1 of the Canadian Electrical Code, in USA Section 810 of the National Electrical Code, provides information with respect to proper grounding of the mast and supporting structure, grounding of the lead-in wire to an antenna discharge unit, size of grounding conductors, location of antenna discharge unit, connection to grounding electrodes, and requirements for the grounding electrode.

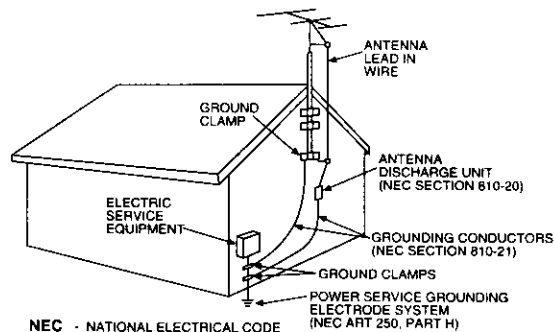

14. **Lightning** — For added protection of this video unit receiver during a lightning storm, or when it is left unattended and unused for long periods of time, unplug it from the wall outlet and disconnect the antenna or cable system. This will prevent damage to the video unit due to lightning and power-line surges.

Important Safeguards

Getting Started

15. **Power Lines** — An outside antenna system should not be located in the vicinity of overhead power lines or other electric light or power circuits, or where it can fall into such power lines or circuits. When installing an outside antenna system, extreme care should be taken to keep from touching such power lines or circuits as contact with them might be fatal.
16. **Overloading** — Do not overload wall outlets and extension cords as this can result in a risk of fire or electric shock.
17. **Objects and Liquids** — Never push objects of any kind into this video unit through openings as they may touch dangerous voltage points or short out parts that could result in a fire or electric shock. Never spill liquid of any kind onto the video unit.
18. **Servicing** — Do not attempt to service this video unit yourself as opening or removing covers may expose you to dangerous voltage or other hazards. Refer all servicing to qualified service personnel.
19. **Damage Requiring Service** — Unplug this video unit from the wall outlet and refer servicing to qualified service personnel under the following conditions:
 - a. When the power-supply cord or plug is damaged.
 - b. If any liquid has been spilled onto, or objects have fallen into the video unit.
 - c. If the video unit has been exposed to rain or water.
 - d. If the video unit does not operate normally by following the operating instructions. Adjust only those controls that are covered by the operating instructions, as an improper adjustment of other controls may result in damage and will often require extensive work by a qualified technician to restore the video unit to its normal operation.
 - e. If the video unit has been dropped or the cabinet has been damaged.
 - f. When the video unit exhibits a distinct change in performance — this indicates a need for service.
20. **Replacement Parts** — When replacement parts are required, be sure the service technician has used replacement parts specified by the manufacturer or have the same characteristics as the original part. Unauthorized substitutions may result in fire, electric shock or other hazards.
21. **Safety Check**— Upon completion of any service or repairs to this video unit, ask the service technician to perform safety checks to determine that the video unit is in safe operating order.

Precautions

USE & LOCATION

- **TO AVOID SHOCK HAZARD ...** Your Camcorder and power supply should not be exposed to rain or moisture. Do not connect the power supply or operate your Camcorder if it gets wet. Your Camcorder has been designed for outdoor use, however it is not designed to sustain direct exposure to water, rain, sleet, snow, sand, dust, or a direct splashing from a pool or even a cup of coffee. This action could permanently damage the internal parts of your Camcorder. Do not attempt to disassemble this unit. There are no user serviceable parts inside. Unplug your Camcorder from the power supply before cleaning.
- **DO NOT AIM YOUR CAMCORDER AT THE SUN OR OTHER BRIGHT OBJECTS**
- **DO NOT LEAVE THE PALMCORDER WITH THE EVF AIMED DIRECTLY AT THE SUN AS THIS MAY CAUSE DAMAGE TO THE INTERNAL PARTS OF THE EVF**
- **DO NOT EXPOSE YOUR CAMCORDER TO EXTENDED HIGH TEMPERATURE ...** Such as, in direct sunlight, inside a closed car, next to a heater, etc... This action could permanently damage the internal parts of your Camcorder.
- **AVOID SUDDEN CHANGES IN TEMPERATURE ...** If the unit is suddenly moved from a cold place to a warm place, moisture may form on the tape and inside the unit.
- **DO NOT LEAVE YOUR CAMCORDER OR THE POWER SUPPLY TURNED ON WHEN NOT IN USE.**
- **STORAGE OF YOUR CAMCORDER ...** Store and handle your Camcorder in a manner that will not subject it to unnecessary movement (avoid shaking and striking). Your Camcorder contains a sensitive pick-up device which could be damaged by improper handling or storage.

CARE

- **TO CLEAN YOUR CAMCORDER ...** Do not use strong or abrasive detergents when cleaning your Camcorder body.
- **TO PROTECT THE LENS ...** Do not touch the surface of the lens with your hand. Use a commercial camcorder lens solution and lens paper when cleaning the lens. Improper cleaning can scratch the lens coating.
- **TO PROTECT THE FINISH OF YOUR CAMCORDER ...** Before handling your Camcorder, make sure your hands and face are free from any chemical products, such as suntan lotion, as it may damage the finish.

For assistance, call 1-800-211-PANA(7262)

Table of Contents

Getting Started

Things You Should Know	2
Important Safeguards	4
Precautions	5
Self Demo Mode	7
Quick Guide	8
Supplying Power	10
Cassette Information	13
Setting the Clock	15
Using the Palmcorder Menu	16
MENU OSD	17
Electronic Viewfinder/LCD Monitor Indications	20
Color Enhancement Light	24
Attaching the Shoulder Strap	25

Basic Operation

Camera Recording	27
Remote Control	30
Playback Your Recordings	32

Special Features

Digital Electronic Image Stabilization System (D.E.I.S.)	38
Zoom	39
Recording Still Pictures	39
Digital Photo Shot	40
White Balance	41
Program AE	42
Digital Functions	43
Focus	44
Audio/Video Fade In/Out	45
Backlight	45
High Speed Shutter	46
Audio Dubbing using the External or Built-in Microphone	47
Memory-Stop Editing	48
Copying your Tapes to S-VHS or VHS Cassette	49
Copying from Digital Equipment (dubbing)	50
PC Connection	51
Using the Digital Photo Printer	52

For Your Information

Palmcorder Accessory System	53
Palmcorder Accessory Order Form	54
Notes On Operations	55
Specifications	57
Before Requesting Service	58
Request for Service Notice	60
Index of Controls	61
Warranty	67
Spanish Quick Use Guide/Guía Para Uso Rápido	69
Index	71

Self Demo Mode

Self Demo mode is on when screen at right appears. Do the steps below to turn off.

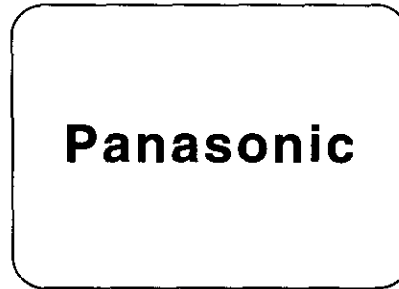
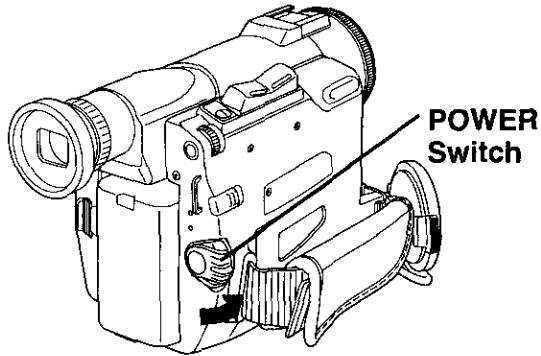

- 1** Set the **POWER Switch** to Camera.
- 2** Press the **LCD-OPEN Button** to unlock the LCD monitor and swing it open.
- 3** Hold down the **STOP Button** for more than 5 seconds.

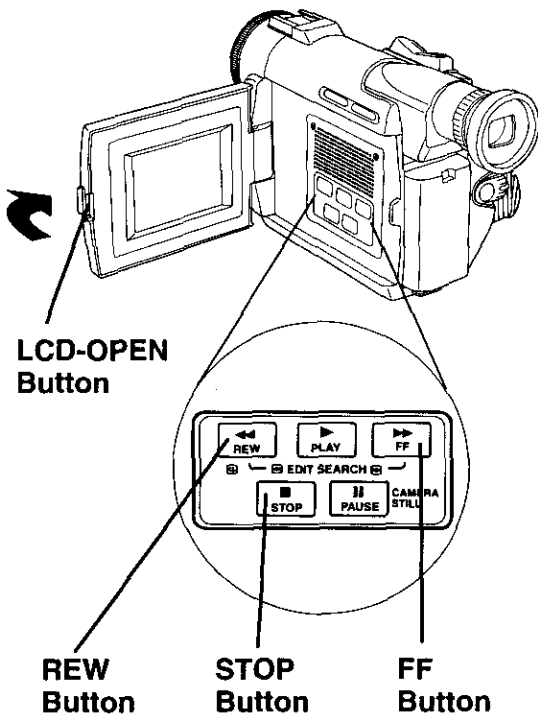

Note:

- Self Demo mode is cancelled if a cassette with rec tab closed is inserted (see pages 13, 14).
- Self Demo mode stops for 3 minutes if a function key is pressed.

To turn Self Demo mode on, do the following:

- Set the **POWER Switch** to **CAMERA**. Hold down **FF** and **REW** Button together for more than 5 seconds. Then, the Self Demo screen will appear on the screen.

Quick Guide

Camera Recording

Before you begin...

- Charge the Battery (see page 10).

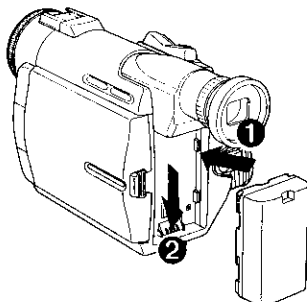

- 1** Insert the **Battery** and slide it down until it locks with a click.

Note:

- The EVF is a fixed type and cannot be extended or retracted. **DO NOT** apply force.
- Do not lift or carry the Palmcorder by the EVF or by the LCD Monitor.

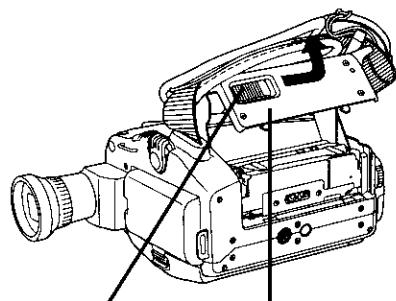

- 2** Slide the **TAPE EJECT Switch** to open the **Cassette Compartment Cover**.
 - The Cassette Holder slides out.

TAPE EJECT Switch **Cassette Compartment Cover**

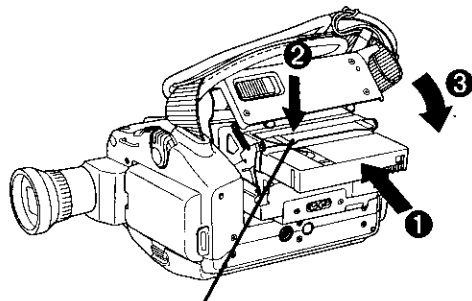

- 3** Insert a cassette with its window side facing up.
 - Make sure the record tab is closed. (see page 14).

PUSH mark

- 4** Press on the **PUSH mark** to close the upper **Cassette Compartment Cover**.
 - The Cassette Holder with the cassette slides back inside.

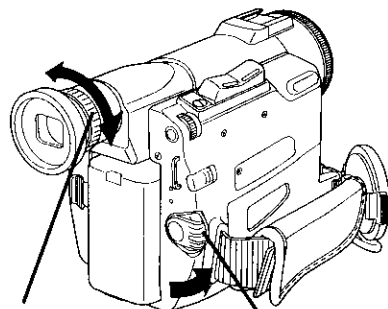

- 5** Close the **Cassette Compartment Cover**.

- 6** Set the **POWER Switch** to **CAMERA**.

Vision Adjustment Control

POWER Switch

- 7** Adjust the **Vision Adjustment Control** to your eyesight.

(Continued on next page.)

Quick Guide

Getting Started

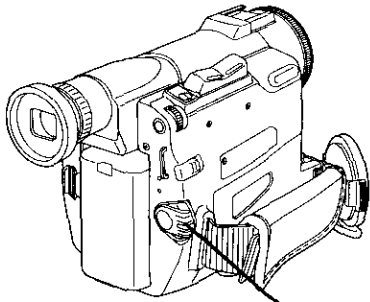

RECORD/
PAUSE Button

- 8 Press RECORD/PAUSE Button to start recording.
Press RECORD/PAUSE Button again to pause recording.

To Watch Playback in the LCD (Liquid Crystal Display)

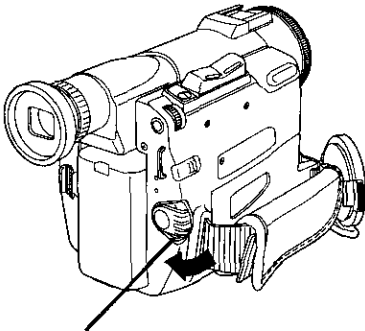

POWER Switch

- 1 Set the POWER Switch to VCR.

Note:

- The EVF is a fixed type and cannot be extended or retracted. DO NOT apply force.
- Do not lift or carry the Palmcorder by the EVF or by the LCD Monitor.

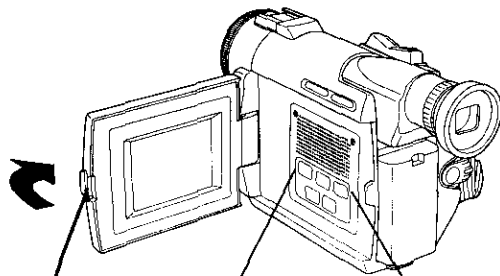

LCD-OPEN
Button

- 2 Press the LCD-OPEN Button to unlock the LCD monitor and swing it open.

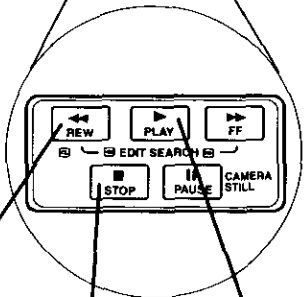

REW
Button

STOP
Button

PLAY
Button

- 3 Press REW to rewind the tape.

- 4 Press PLAY to start playback.

- 5 Press STOP to stop playback.

Supplying Power

Charge the Battery Pack on the AC Adaptor

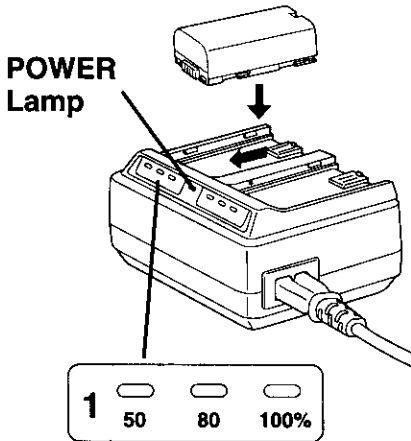
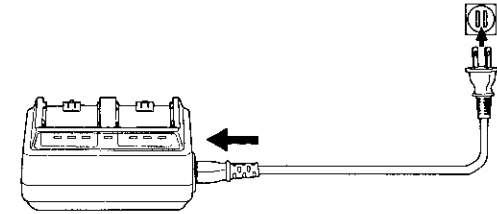

1 Connect and plug in the Cable as shown.

- POWER Lamp will light.
- Disconnect DC Cable if it is connected to AC Adaptor.

2 Attach the battery as shown to charge.

- Charge lamps on the AC Adaptor will flash and then turn solid green to indicate current charge level. When all 3 lamps are constantly on, the battery is fully charged. (approx. 1 hour)
Expect approx. 1 hour 15 minutes of operation when fully charged (EVF usage).

3 Remove the Battery.

Slide the Battery out and then lift up.

About the Charge Lamps

- The three Charge Lamps “50%”, “80%” and “100%” flash and then remain lit one after another to indicate how much the Battery has been charged. When all three lamps are lit, charging is finished.
- The Charge Lamps give a good approximate indication of the charging condition under normal ambient temperature. However, when charging at high or low temperature, the charge lamps may differ considerably from the actual charging condition.
- When you charge two batteries, charging starts from Battery 1. At this time, the Charging Lamps for Battery 2 show the remaining charge of Battery 2. (If the remaining charge is less than 50%, no Charge Lamp is lit.)

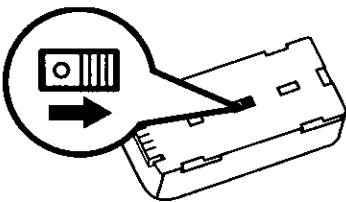

Battery Charging Confirmation Marker

Use this marker as a reminder to yourself when the battery is fully charged or in need of a charge. This marker performs no function and is for your reference only.

- The Battery is no longer serviceable if the operation time is very short, even after a sufficient charge.

Supplying Power

Insert/Remove the Battery Pack

Getting Started

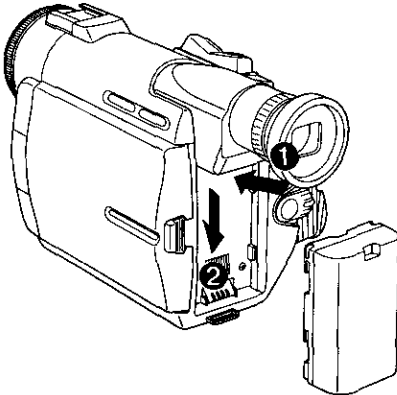

Insert the Battery and slide it down until it locks with a click.

Note:

- The EVF is a fixed type and cannot be extended or retracted. **DO NOT** apply force.
- Do not lift or carry the Palmcorder by the EVF or by the LCD Monitor.

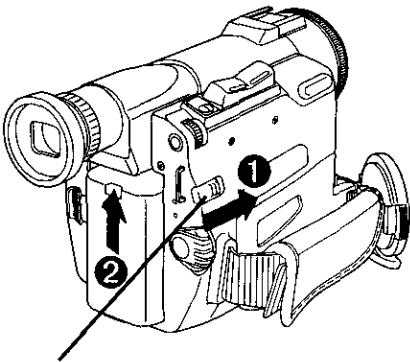

To remove the Battery:

Slide the Battery upward while sliding the **BATTERY RELEASE** Button.

BATTERY RELEASE Button

Battery Care

Caution:

- Charge only with specified charger.
- The Battery can be charged within a temperature range of 32° F (0° C) and 104° F (40° C).
- The Battery may be warm after charging or just after use. This is normal.
- Do not use an insufficiently charged or worn out Battery.
- In extreme cold surroundings, Battery charging time will increase.

Safety precautions:

- Do not get the Battery near, or dispose of in fire.
- Do not directly connect (short circuit) the positive (+) and negative (-) terminals.
- Never attempt to disassemble or reassemble the Battery.

To avoid damage to the Battery:

- Do not drop or jar the Battery.
- Use the Battery with specified models only.
- If the Battery is used in extremely high temperatures, a safety device will automatically prevent operation.

To insure longer battery life:

- **While not in use, remove Battery from the Palmcorder and AC Adaptor and store in a cool, dark, dry place.** If you leave the Battery in the Palmcorder or on AC Adaptor, the Battery will no longer be rechargeable.
- Keep the Battery terminals clean.

Supplying Power

AC Adaptor

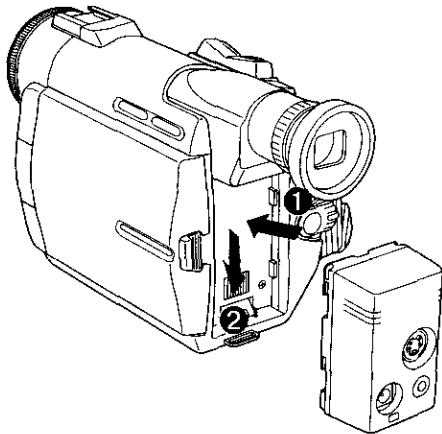

1 Insert the **Jack Box** and slide it down until it locks with a click.

Note:

- The EVF is a fixed type and cannot be extended or retracted. DO NOT apply force.
- Do not lift or carry the Palmcorder by the EVF or by the LCD Monitor.

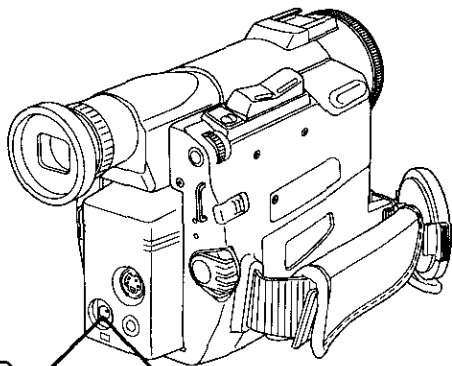

2 Insert the **DC Cable** into the **Jack Box**.

3 Connect the other end of the **DC Cable** to the **AC Adaptor** as shown.

4 Plug in the **AC Adaptor**.
• The **POWER Lamp** lights up.

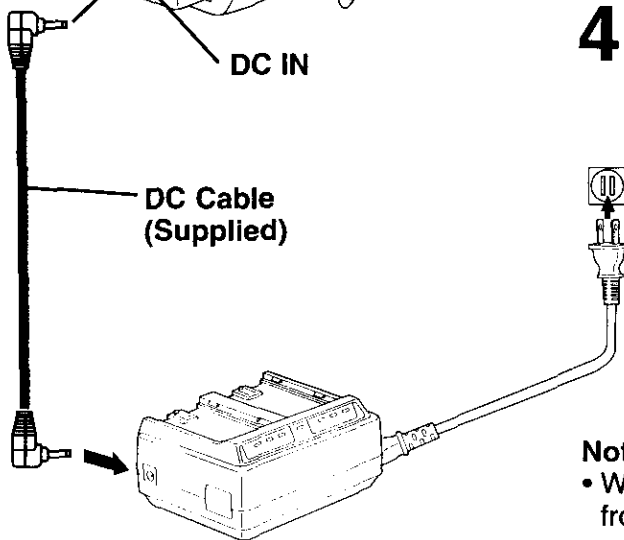

Note:

- When not in use, unplug the AC Adaptor from the AC outlet. (AC Adaptor consumes 1W of electric power when plugged into an AC outlet even when not in use.)

Cassette Information

Cassette Insertion

Connect the Palmcorder to a power source.

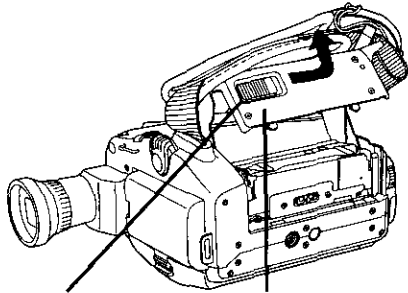

TAPE EJECT
Switch

Cassette
Compartment Cover

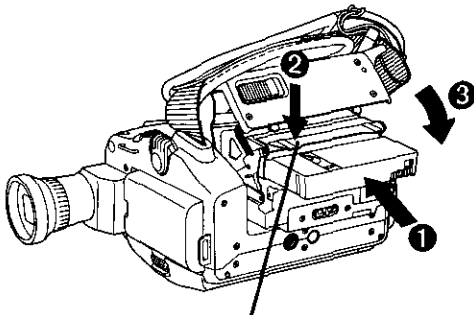

PUSH mark

- 1** Slide the **TAPE EJECT Switch** to open the **Cassette Compartment**.
 - The **Cassette Holder** slides out.
- 2** Insert a **cassette** with its window side facing up.
- 3** Press on the **PUSH** mark to close the upper **Cassette Compartment Cover**.
 - The **Cassette Holder** with the cassette slides back inside.
- 4** Close the lower **Cassette Compartment Cover**.

Cassette Ejection

- If the Palmcorder is connected to a power source, the cassette can be inserted and ejected without turning the Palmcorder on.

- 1** Slide the **TAPE EJECT Switch** to open the **Cassette Compartment**.
 - The **Cassette Holder** slides out.
- 2** Pull the **cassette** straight out.

Hint for inserting the cassette

- When you insert a cassette that is partially recorded, use the Edit Search Function to search for the position from which you want to record again. Especially when you want to record again on a cassette that is already fully recorded, be sure to first locate the position where you want to add the new recording, before starting to record.

Notes

- If hand strap is tight it may prevent Cassette Holder from fully opening for tape insert or eject. Loosen hand strap if necessary.
- After the Cassette Holder has been retracted completely, close the lower Cassette Compartment Cover.
- When inserting the cassette, make sure it faces in the right direction and then push in completely.

If the Cassette Holder does not retract completely, take the following measures:

- Press **PUSH** mark to securely close the upper Cassette Compartment Cover.
- Turn the Palmcorder on again with the **POWER** Switch.

If the Cassette Holder does not slide out, take the following measures:

- Close the Cassette Compartment Cover completely and then open it again.

Cassette Information

Record Speed/Playback Time

Use only those tapes having the ^{Mini} DV logo indicating the 6.35mm digital standard.

Cassette type	Record Speed/Playback time	
	SP	LP
AY-DVM30EA	30 minutes	45 minutes
AY-DVM60EA	60 minutes	90 minutes
AY-DVM80EA	80 minutes	120 minutes

Erase Protection

Cassettes have a sliding record tab to ensure recordings are not accidentally erased.

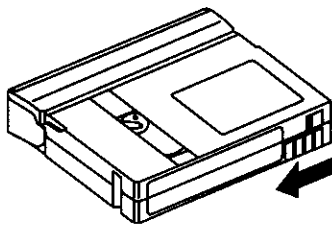

- 1 To prevent accidental erasure**
Slide the tab to the left (open).

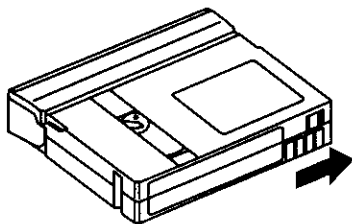

- 2 To record again**
Slide the tab to the right (close).

Setting the Clock

Set the Date and Time

The date and time is calculated, including leap year, up to DEC 31 2089.

MENU Button

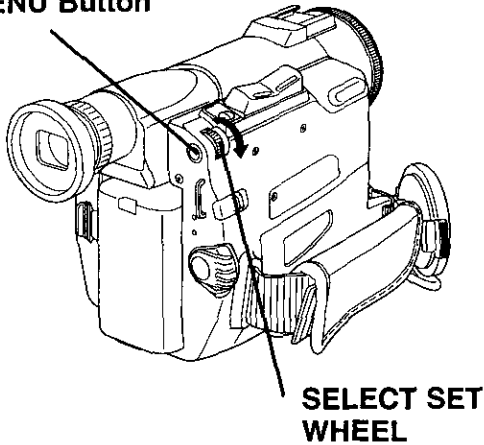

EXAMPLE:

YEAR : 1998



Rotate

YEAR : 1999



Push

MONTH : JAN

Before you begin...

- Connect the Palmcorder to a power source.
- Set the POWER switch to CAMERA.

- 1** Press **MENU** to display the Camera Mode menu screen (see page 17).
- 2** Rotate the **SELECT SET WHEEL** to select **CLOCK-SET**.
- 3** Press **SELECT SET WHEEL** down to select **CLOCK-SET ON**. The **DATE/TIME SETTING** menu appears.
- 4** Rotate the **SELECT SET WHEEL** to select the desired numbers, then, press **SELECT SET WHEEL** down to fix that portion and move to the next. Adjust the shaded items for the Year, month, day, hour, and minute.

Getting Started

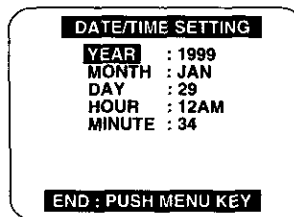

When time setting is completed, press the MENU Button to start the clock.

Note:

- If you should pass the current year, continue pressing down on the SELECT SET WHEEL until the year appears again.
- A built-in battery maintains clock operation. If the Palmcorder is not connected to a power source for a few months, the built-in battery may discharge and "CLOCK BATTERY" indication appears (see page 23).

Using the Palmcorder Menu

The Palmcorder features two menu displays: one for camera mode (recording) and the other for VCR mode (Playback).

- While the Menu screen is displayed, you cannot record or play the tape.
- While recording, the Menu screen will not be displayed.
- While in playback, the Menu screen can be displayed.

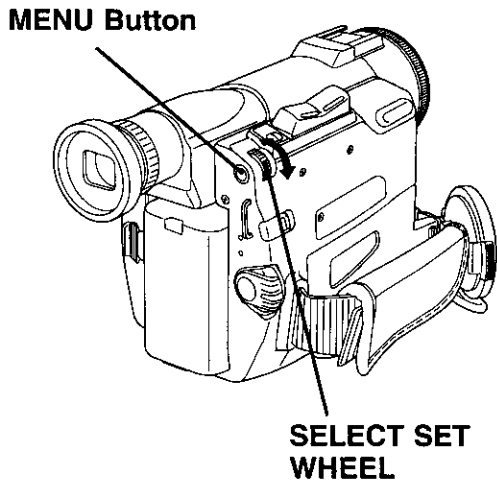

Displaying the MENU

Before you begin...

- Connect the Palmcorder to a power source.
- Set the POWER Switch to CAMERA.

1 Press the MENU Button to display the CAMERA menu.

2 Set the POWER Switch to VCR to change to the VCR menu if desired.

Setting the MENU Items

1 Rotate the SELECT SET WHEEL to select a menu item.

- The character of your selection will be inversely displayed.

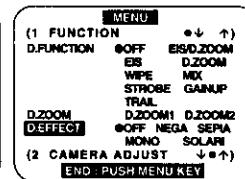
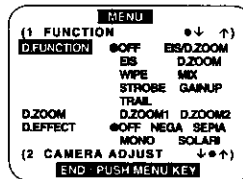

2 Press down on the SELECT SET WHEEL to set your selection.

- The "●" mark will indicate your selection.

3 Press MENU Button to exit from the display.

Note:

- Rotate the SELECT SET WHEEL to display additional lines.
- If you select ALL at COLLAPSE, then return to main menu.

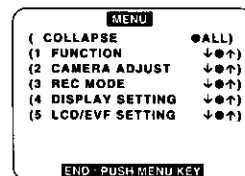

- If you select desired item from the main menu, detailed items will show up on the screen.







Camera Mode Menu Screen

(1 FUNCTION ●↓ ↑)

- a. D. FUNCTION ●OFF EIS/D.ZOOM
EIS D.ZOOM
WIPE MIX
STROBE GAINUP
TRAIL
- b. D. ZOOM D.ZOOM1 D.ZOOM2
- c. D. EFFECT ●OFF NEGA SEPIA
MONO SOLARI

- a. **DIGITAL FUNCTION** (pages 38, 43)
To select one of the 8 digital functions. Setting to OFF cancels the previously selected digital function.
- b. **D. ZOOM** (page 39)
To select the desired zoom range.
D.ZOOM1: Digital zoom from 18x to 36x.
D.ZOOM2: Digital zoom from 18x to 300x.

(2 CAMERA ADJUST ●↓ ↑)

- d. PROG. AE ●OFF   
- e. W.BALANCE   
- f. SHUTTER ●AUTO
SET ●(AUTO)

- c. **D.EFFECT** (page 43)
To select one of the 4 digital picture effects for recording. Setting to OFF cancels the previously select digital effect.
- d. **PROG. AE** (page 42)
To select one of the 5 Program AE modes. Setting to OFF cancels the previously selected Program AE mode.

(3 REC MODE ●↓ ↑)

- g. REC-SPEED ●SP LP
- h. AUDIO-REC ●12 bit 16 bit
- i. SHUTTER ●OFF ON
- j. WIND-CUT ●OFF ON
- k. REMOTE OFF ●VCR1 VCR2
- l. INDEX ●DAY 2HOUR
- m. TALLY-LED OFF ●ON
- n. BEEP OFF ●ON

- e. **W.BALANCE** (page 41)
To select one of the 3 White Balance modes.
- f. **SHUTTER** (page 46)
To select a desired shutter speed.
- g. **REC-SPEED** (page 14)
SP: Normal recording speed mode.
LP: Recording time is 1.5 times as long as in the SP mode. For example, 90 minutes recording is possible on a 60-minutes tape.

(4 DISPLAY SETTING ●↓ ↑)

- o. DISPLAY OFF ●LINEAR
MEMORY T.CODE
- p. C.RESET ●OFF ON
- q. DATE/TIME OFF ●D/T DATE
- r. CLOCK-SET ●OFF ON

- h. **AUDIO-REC** (page 47)
12 bit: The sound is recorded in the 12 bit/32 kHz mode.
16 bit: The sound is recorded in the 16 bit/48 kHz high-quality mode.

(5 LCD SETTING ●↓ ↑)

- s. SELF-REC ●NORMAL MIRROR
- t. LCD SET ●OFF ON

- i. **SHUTTER** (page 40)
When set to ON, still pictures taken in the PhotoShot mode are recorded with a visual shutter effect and click sound.

(COLLAPSE ALL)

MENU OSD

j. **WIND-CUT** (page 27)

To reduce sound distortion caused by wind hitting the microphone. However, this slightly deteriorates the sound reproduction in the bass range.

k. **REMOTE** (page 31)

Optional Remote Control Only

VCR1: To receive signals from the Remote Control set to VCR1.

VCR2: To receive signals from the Remote Control set to VCR2.

OFF: To prevent reception of signals from the Remote Control.

l. **INDEX** (page 35)

DAY: An index signal is recorded when recording is restarted after the date has changed since the last recording.

2 HOUR: An index signal is recorded when recording is restarted after a lapse of more than 2 hours.

m. **TALLY-LED** (page 27)

Tally LED lights during recording when set to ON.

n. **BEEP**

Set to ON to beep when starting and stopping camera recording or when unusual conditions occur. To cancel the beep, set to OFF.

Palmcorder will beep:

- Once when you start recording
- Twice when you stop recording
- Repeatedly when warning of unusual conditions (pages 22, 23).

o. **DISPLAY** (page 20)

To select the desired type of display and counter indication displayed on the LCD Monitor or in the viewfinder.

p. **C.RESET** (page 20)

Setting to ON, resets the counter to zero.

q. **DATE/TIME** (page 21)

To display the date and time can be set on the screen.

r. **CLOCK-SET** (page 15)

When set to ON, the date and time can be set on the screen.

s. **SELF-REC** (page 28)

NORMAL: During self-recording, the picture on the LCD Monitor is the same as it will be recorded.

MIRROR: During self-recording, the picture on the LCD Monitor is horizontally reversed.

t. **LCD SET** (page 28)

Setting to ON displays the menu for adjusting the LCD brightness and color level.

MENU OSD

VCR Mode Menu Screen

(1 VCR SETTING ●↓ ↑)

u. B.SEARCH ●OFF ON
v. INDEX ●PHOTO SCENE
w. AUDIO ●ST1 ST2 MIX
REMOTE OFF ●VCR1 VCR2
REC-SPEED ●SP LP

u. **B.SEARCH (Book Mark Search)**
(page 30)

Select ON to go directly to a blank portion of the tape.

v. **INDEX** (page 35)

To select the desired Index Search function.

PHOTO: To search for Photoshot pictures.

SCENE: To search for scenes marked with Index signal.

w. **AUDIO** (pages 47, 48)

To select the desired audio playback mode after performing audio dubbing in the 12 bit mode.

ST1: The original sound alone is played back.

ST2: The dubbed sound alone is played back.

MIX: The original sound and the dubbed sound are played back together.

(2 DISPLAY SETTING ●↓ ↑)

DISPLAY OFF ●LINEAR
MEMORY T.CODE
C.RESET ●OFF ON
DATE/TIME OFF ●D/T DATE
CLOCK-SET ●OFF ON

(3 LCD SETTING ●↓ ↑)

LCD SET ●OFF ON

(COLLAPSE ALL)

Electronic Viewfinder/LCD Monitor Indications

Here are some of the basic indications which appear in the Palmcorder EVF and LCD Monitor. These indications except the Date and Time will not be recorded on the tape.

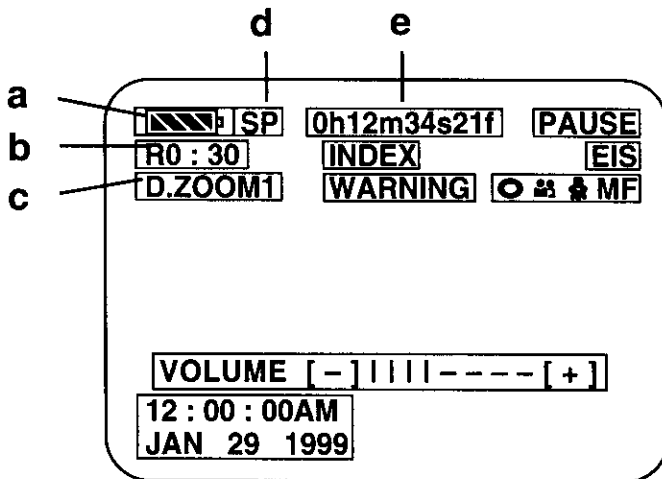

a. Battery Remaining

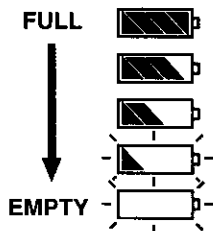

• When you are using the AC Adaptor, the Battery Remaining indication may not show FULL. This is normal.

b. Tape Remaining

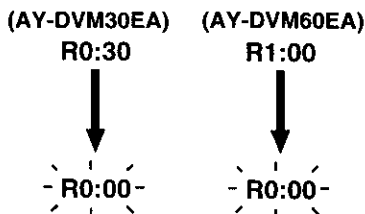

• It will take several seconds for the tape remaining indicator to operate after the tape starts moving.

c. Digital Zoom (page 39)

This display appears when the digital zoom function has been activated.

d. Tape Speed Indication (page 17)

Indicates the tape speed (SP or LP).

e. Display On/Off and Counter/Time Code

The indication switches as shown below when the desired "DISPLAY" mode is selected from the menu (page 18).

• Even if display off is selected, the Tape Mode and Date and Time indication can be displayed.

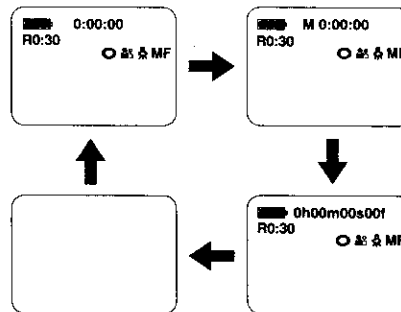

Memory Counter M 0:00.00

The Palmcorder will stop whenever it reaches the point where the counter was previously set to M 0:00.00 during audio dub, fast forward or rewind.

Time Code 0h00m00s00f

The Palmcorder calculates and displays exactly where you are on any tape in terms of hours, minutes, seconds, and frames (30 frames = 1 second).

• This display can not be reset.

IMPORTANT NOTE:

Display must be set to ON for MF, AE, W. BALANCE or BACK LIGHT indications to be displayed on the EVF or LCD Panel when selected.

Electronic Viewfinder/LCD Monitor Indications

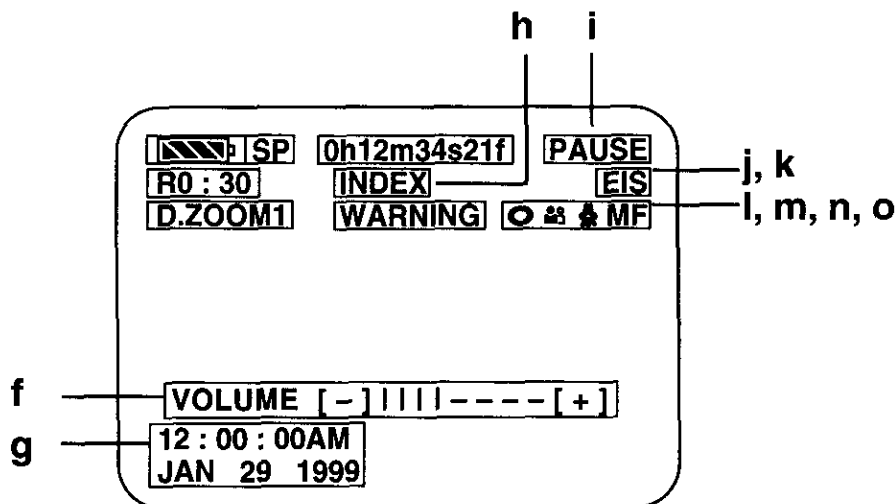

f. Volume Display (page 32)

The volume bar appears when the volume of the built-in speaker is being adjusted.

g. Date and Time Indication (page 18)

As shown below, the date and time indication changes each time the DATE/TIME is selected from the Palmcorder's MENU (page 18) or the DATE/TIME Button is pressed on the remote (optional).

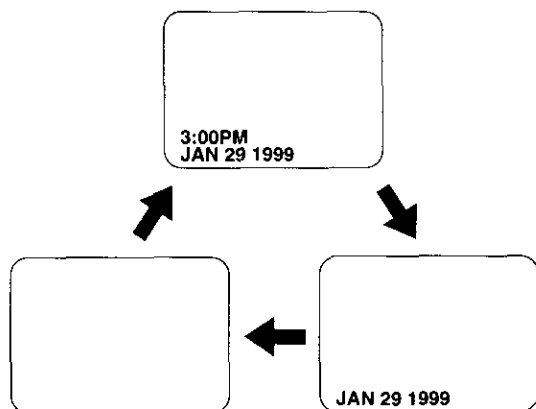

h. INDEX (page 35)

This display appears when an index signal is being recorded.

i. Tape Mode Indications

- REC** Recording.
- PHOTO** Photo Shot Recording.
- PAUSE** Paused during recording.
- PLAY** Playback.
- R** ▷ Repeat Playback.
- CHK** Recording Check.
- FF** Fast forward.
- REW** Rewind.
- ▷▷ FF Search.
- ◁◁ REW Search.
- BLANK** Book Mark Search.
- SEARCH** Edit Search.
- Mirror feature recording.
- || Paused during Mirror feature recording.

j. Digital EIS Indications (page 38)

k. Zoom Magnification Level (page 39)

l. Manual Focus Indication (page 44)

m. White Balance Indication (page 41)

n. PROGRAM-AE Indication (page 42)

o. Backlight Indication (page 45)

Electronic Viewfinder/LCD Monitor Indications

The following warning displays appear in the EVF and the LCD monitor.

Warning Indications

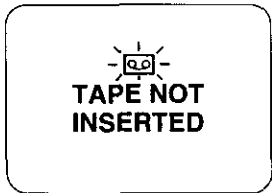

— If the Palmcorder is in CAMERA mode without a cassette inserted, "Ⓜ" will flash and "TAPE NOT INSERTED" will appear for 5 seconds. Recording will not start.

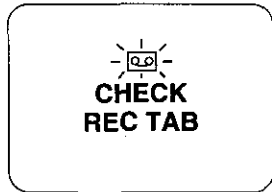

— If the Palmcorder is in CAMERA mode with the cassette sliding record tab opened, "Ⓜ" will flash and "CHECK REC TAB" will appear for 5 seconds. Recording will not start.

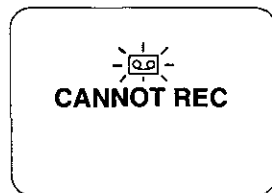

— When Audio dub is performed and the sliding record tab is open, or a blank portion of tape is detected, "Ⓜ" will flash and "CANNOT REC" will appear for 5 seconds.

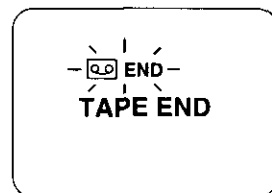

— When the tape is about to end in REC mode, "ⓂEND" will flash and "TAPE END" will appear for 5 seconds.

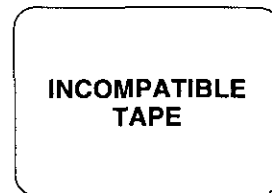

— When an incompatible tape is detected, "INCOMPATIBLE TAPE" will appear for 5 seconds.

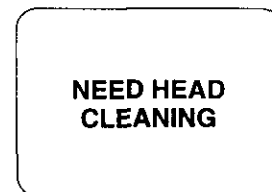

— If the video heads require cleaning, "NEED HEAD CLEANING" will appear for 5 seconds.

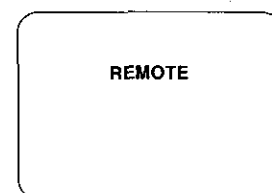

— When the Palmcorder and remote are not set to the same mode (VCR1 or VCR2), "CHECK REMOTE MODE" will also appear for 5 seconds when the Palmcorder is first turned on.

Electronic Viewfinder/LCD Monitor Indications



When an AUDIO DUB is attempted on a pre-recorded LP tape, "CANNOT REC LP-MODE" will appear for 5 seconds.



When the DV connection is not securely connected, "CHECK DV-INPUT" will appear for 5 seconds. Check the connections.

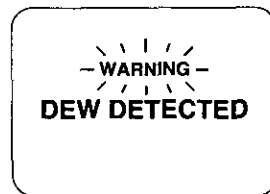

If excessive moisture condenses in the unit, "WARNING" will flash, "DEW DETECTED" will appear, and the Palmcorder will automatically turn OFF in 15 seconds. In this case, wait until the indicator no longer flashes when your Palmcorder is turned on again.

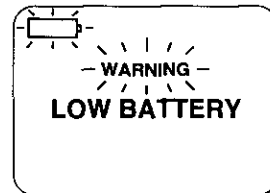

When a battery recharge is necessary, "WARNING" will flash, "LOW BATTERY" will appear, and the Palmcorder will automatically turn OFF in 15 seconds. (page 20).

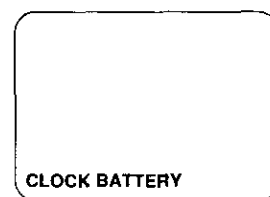

When the built-in lithium clock battery is discharged, "CLOCK BATTERY" will appear. To re-charge the lithium clock battery, connect the AC Adaptor to the Palmcorder. Recharging takes approx. 4 hours. Reset the clock after charging.

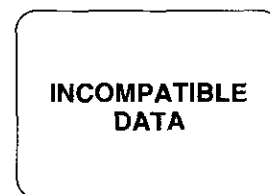

When a pre-recorded tape other than NTSC format is inserted for play, or you attempt to copy a protected copy-guarded tape, "INCOMPATIBLE DATA" will appear for 5 seconds.

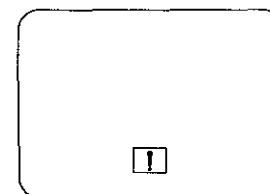

When the LCD monitor is rotated 180° so that it faces the same direction as the lens, the "!" mark indicates that a warning message exists during Mirror feature. To view the warning, return the LCD monitor to the original position.

Color Enhancement Light (Optional)

Using the Light

To brighten the natural colors in a scene (Optional, page 53).

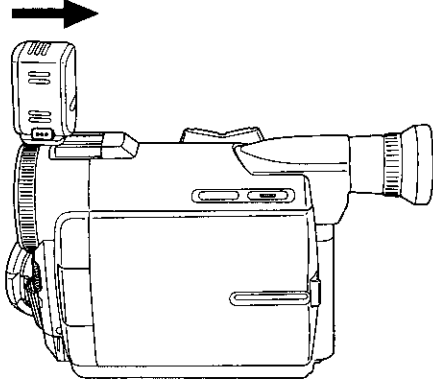

1 Slide Light into the Built-in Light Mount.

Be sure it locks into place.

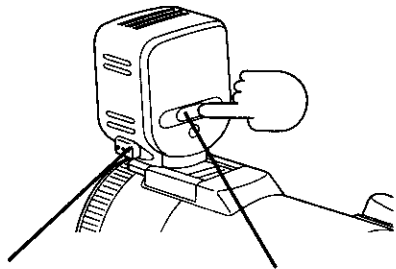

2 Press LIGHT Button ON.

3 Press LIGHT Button again to OFF.

LIGHT RELEASE Button LIGHT Button

To remove the Light:

Press LIGHT RELEASE Button and slide the Light out of the mount.

Caution:

This light becomes hot during operation. Make sure nothing covers the Light during operation.

Note:

- Using the light will reduce battery operating time.
- If using the enhancement Light for an extended period of time, be sure to provide ventilation when using it in a hot environment.
- Be sure LIGHT Button is set to OFF when not in use.
- Do not attempt to lift or carry the Palmcorder by holding the Enhancement Light.
- If light bulb needs to be replaced, take Light to your nearest service center.

Attaching the Shoulder Strap

Getting Started

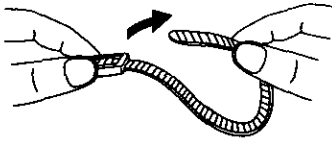

1 Undo the two strap ends from their buckles.

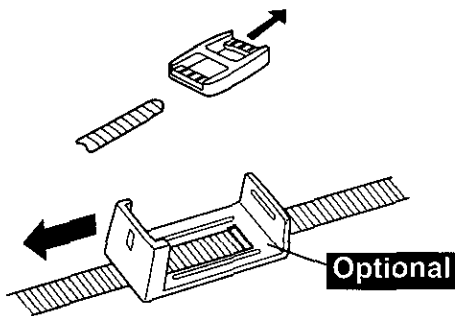

2 Remove the buckle from one end of the strap.

3 Thread the strap (with no buckle) through the Light Holder (included with optional color enhancement light) so that it faces outward. Then reinsert the buckle.

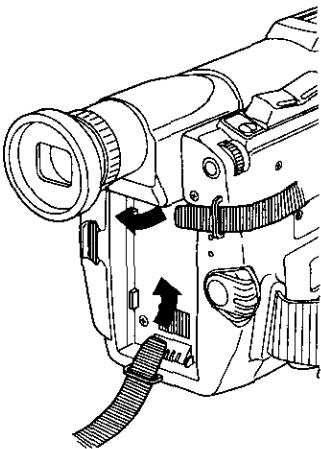

4 Thread the strap ends through the Strap Attachment Rings.

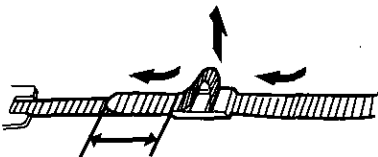

5 Reinsert the strap ends through their buckles.
• Make sure the straps are not twisted.

Adjust the Length

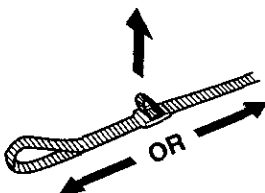

1 Loosen the strap from the Buckle and create a loop.

2 Pull the strap firmly through the Buckle to shorten or lengthen the strap.

Attaching the Shoulder Strap

Hand Strap

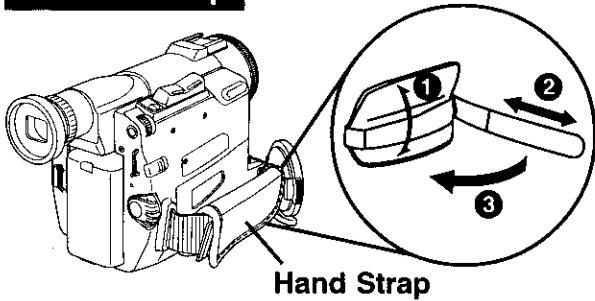

Adjust the length of the Hand Strap to the size of your hand as illustrated.

Lens Cap

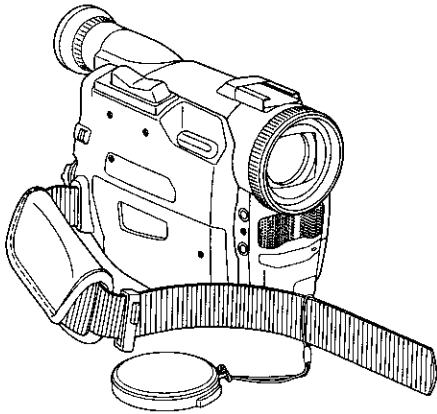

Attaching the Lens Cap Cord to the Hand Strap

Remove the Hand Strap from the front clasp and run the Strap through the Lens Cable Loop.
Reattach the Hand Strap.

Camera Recording

Simple Recording

Remove the lens cap and clip it to the hook.

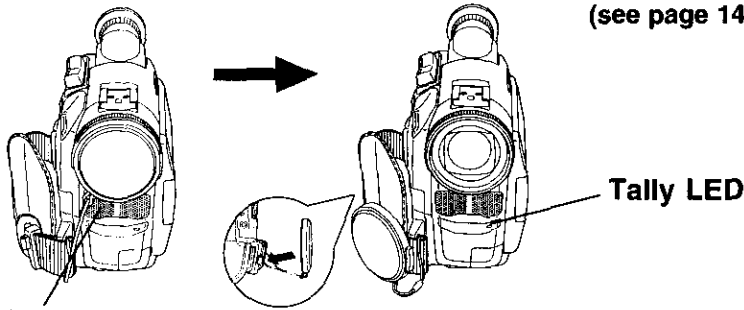

Before you begin...

- Connect the Palmcorder to a power source.
- Insert a cassette with record tab closed (see page 14).

Built-In Twin Capsule 2-Way Microphone System

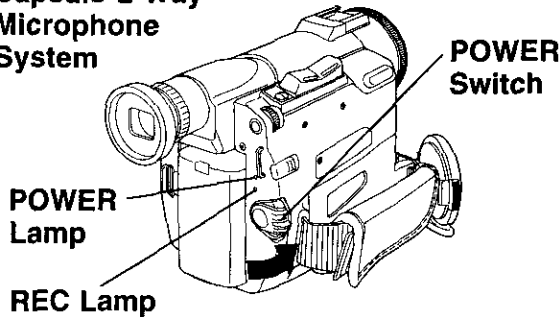

- 1 Set **POWER Switch** to **CAMERA**.
 - The **POWER lamp** lights red.

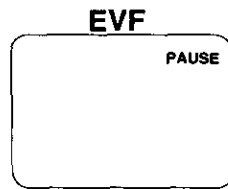

Record/Pause mode.

- 2 With the **Viewfinder Eye Cup** up to your eye, adjust the **Vision Adjustment Control** to your eyesight. (page 8)

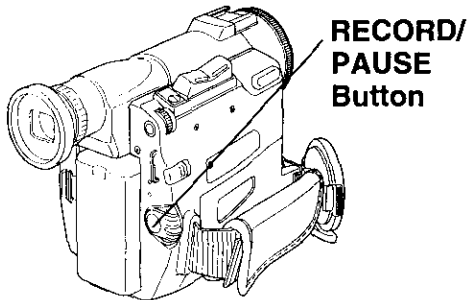

- 3 Press **RECORD/PAUSE Button** to start recording.
The **Tally LED** and **REC Lamp** will be on.
To turn the **Tally LED** off, see **TALLY LED** on page 18.
Press **RECORD/PAUSE Button** again to pause recording.
 - To reduce microphone wind noise, set the **WIND-CUT** to **ON** (see **WIND-CUT** on page 18).

WARNING:

- Do not lift or carry the Palmcorder by the **EVF** or by the **LCD Monitor**.

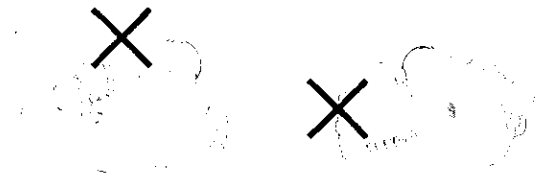

- When the Palmcorder is aimed at excessively bright objects, or bright lights, a vertical bar may appear in the picture. This is a normal characteristic of the **CCD** pick-up device. Try to avoid this whenever possible.

To conserve power

After 5 minutes, the Record/Pause mode will automatically change to Standby mode. To resume recording, set **POWER** to **OFF** and then **ON** again.

Camera Recording

Using the LCD Monitor

The LCD (Liquid Crystal Display) monitor can be used while recording.

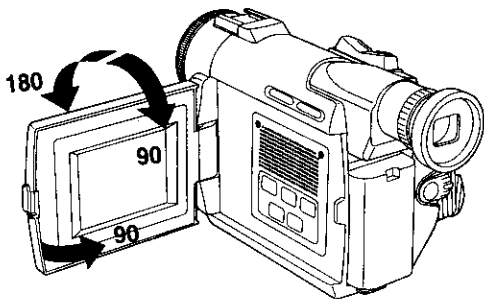
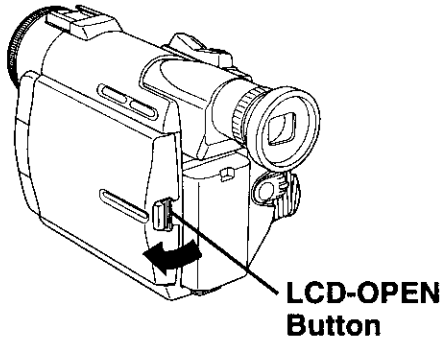

Before you begin...

- Connect the Palmcorder to a power source.
- Insert a cassette with record tape (see page 14).

1 Press the LCD-OPEN Button to open the LCD monitor.

2 Swing the LCD monitor fully open and adjust the angle.

- The LCD monitor will automatically turn on.
- When the LCD monitor is closed, it will shut off automatically to save power.
- Adjust the LCD monitor if necessary.

3 Start recording (page 27).

Note:

- Using the LCD monitor will reduce operating time.
- Close the LCD monitor completely when not in use.

- 1 Press the MENU Button to display the menu screen.
- 2 Rotate the SELECT SET WHEEL to select LCD SET from the menu screen (page 18).
- 3 Press the SELECT SET WHEEL to display the LCD monitor adjustment screen.
- 4 Press the SELECT SET WHEEL to select BRIGHT or COLOR, then rotate the SELECT SET WHEEL to adjust them.
- 5 Press the MENU Button to exit this mode.

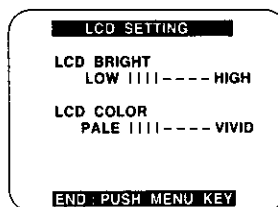

Self Recording

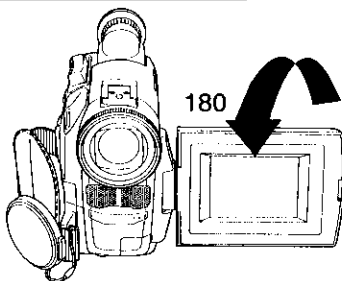

Rotate the LCD monitor 180 degrees so that it faces in the same direction as the lens, while in the CAMERA mode, to record yourself.

The picture in the LCD Viewfinder will appear reversed. Select SELF-REC MIRROR (page 18) in the Camera menu screen to see the picture as it is actually being recorded.

Camera Recording

Recording Check

To play back the final few seconds of the last recorded scene in the Recording Pause Mode.

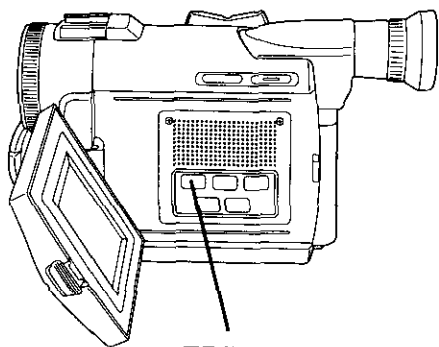

EDIT SEARCH ◀◀

Press the **EDIT SEARCH** Button ◀◀ briefly in the recording Pause Mode.

The [CHK] indication appears. After checking, the Movie Camera returns to the Recording Pause Mode.

- For Recording Check, the Movie Camera must be in the same mode (SP or LP) as used for recording, otherwise the playback picture is distorted.

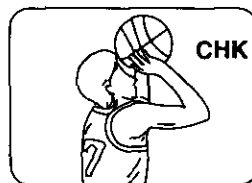

Edit Search

You can visually search for scenes in CAMERA mode to maintain proper continuity when taping.

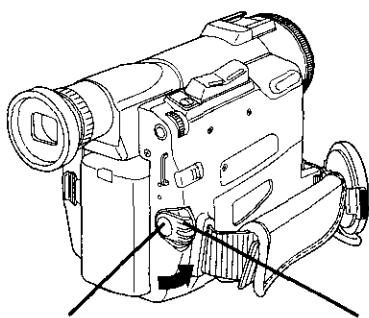

RECORD/PAUSE Button

POWER Switch

EDIT SEARCH ◀◀ EDIT SEARCH ▶▶

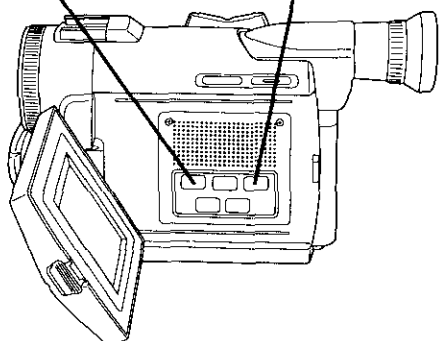

- 1 Set **POWER** Switch to **CAMERA**.
- 2 In **RECORD/PAUSE** mode, hold down **EDIT SEARCH** ▶▶ to perform a forward visual search or **EDIT SEARCH** ◀◀ to perform a reverse visual search. Releasing the button stops the search.
- 3 Press **RECORD/PAUSE** to continue recording.

Record Review:

Press **EDIT SEARCH** ◀◀ once while in Record/Pause mode to review the last few seconds of your recording.

Note:

- During Edit Search, the picture will become mosaic in both search, the sound will be muted in reverse visual search.
- Make sure the SP/LP tape speed setting is the same as the recording to eliminate distortion during edit search.

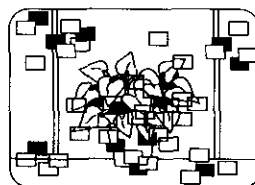

Camera Recording / Remote Control

Book Mark Search

You can go directly to a blank portion of tape and start recording exactly where you left off.

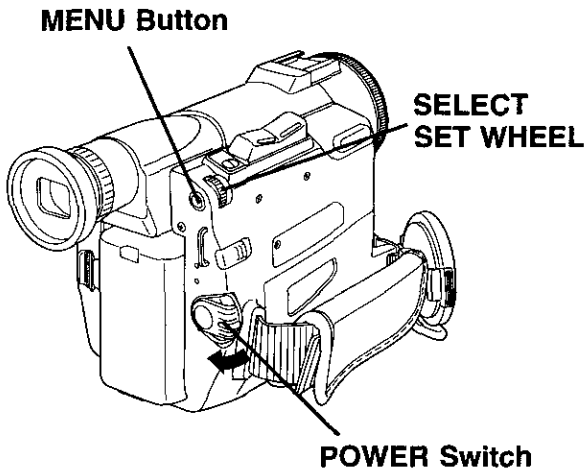

- 1** Set the **POWER Switch** to **VCR**.
- 2** Press **MENU Button** to display the menu screen. Then rotate the **SELECT SET WHEEL** to select **B.SEARCH** (see page 19).
- 3** Press the **SELECT SET WHEEL** to select **ON**. The Palmcorder will start a forward Book Mark Search.

Remote Control (Optional)

You can operate the major functions of your Palmcorder from up to approximately 16 feet (5 m) away (indoors). Aim the IR Remote Control toward the front of the Palmcorder and press the desired buttons (sensor is located under the lens).

To operate Camera functions:

Set the **POWER Switch** to **CAMERA**.

To operate VCR functions:

Set the **POWER Switch** to **VCR**.

Controlled Functions

- Rec/Pause (page 27)
- Tele (Zoom) (page 39)
- Wide (Zoom) (page 39)
- Date/Time (page 21)
- Reset (page 48)
- Photo Shot (page 40)
- Display On TV (page 37)
- Counter/Time Code (pages 20, 48)
- Audio Dubbing (page 47)
- Record (page 50)
- Menu (page 16)
- Play (page 32)
- FF/Search (page 33)
- REW/Search (page 33)
- Pause/Select (pages 16, 33)
- Stop/Set (pages 16, 32)
- Slow/Frame Advance (Forward) (pages 33, 35)
- Slow/Frame Advance (Backward) (pages 33, 35)
- Index Search (Forward) (page 35)
- Index Search (Backward) (page 35)
- Speaker Volume (page 32)

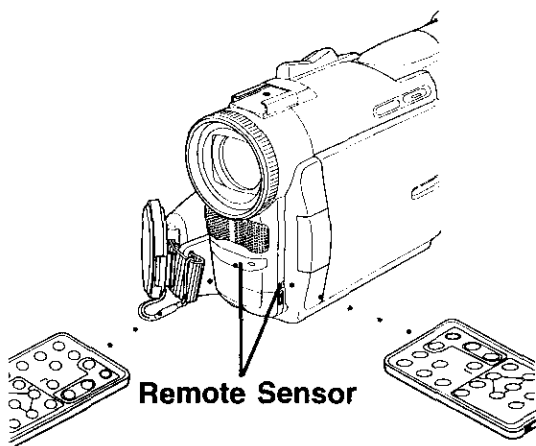

Remote Control (Optional)

Remote Controlling Two Palmcorders

You can control any two PV-DV900's with one Remote control (Optional, page 53). In order for the remote to distinguish between the two units, it is necessary to set one of the Palmcorders to VCR 2. On the remote, press VCR 1 or VCR 2 to control the desired Palmcorder.

Optional

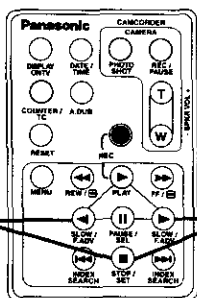

For VCR 2 :
Press these buttons at same time.

For VCR 1 :
Press these buttons at same time.

1 Display the menu and select REMOTE VCR 2 on one Palmcorder (page 18). Leave the other Palmcorder set to VCR1.

2 Set the Remote Control (Optional, page 53) to VCR 1 or VCR 2 to correspond with the Palmcorder you wish to control. (See illustration at left.)

Note:

- When the Palmcorder and remote are not set to the same mode (VCR1 or VCR2), "CHECK REMOTE MODE" will appear.

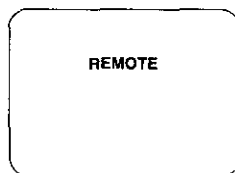

- After replacing the Remote Control Battery, the remote will default to VCR 1.

Basic Operation

Replace the Battery

Optional

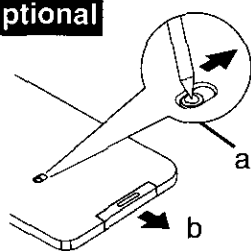

1 Insert a slender, pointed object, such as the tip of a ball-point pen into the slot so that it fits into the hole (as shown a). Then, while sliding to the right, pull the battery holder out with your fingernail.



2 Insert the battery into the Battery Tray with the ⊖ mark facing up. Do not reverse the polarity.

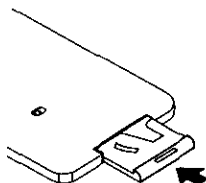

3 Replace the Battery Tray.

Replace battery with Panasonic PART NO. VSBW0004 (CR2025) only. Use of another battery may present a risk of fire or explosion. Caution-battery may explode if mistreated. Dispose of used battery promptly. Keep away from children. Do not recharge, disassemble or dispose of in fire.

Playback your Recordings

Playback using the LCD Monitor

You can also use the LCD monitor to playback your recording.

LCD-OPEN
Button

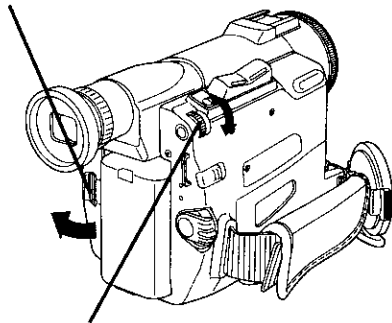

VOLUME WHEEL

Built-in Speaker

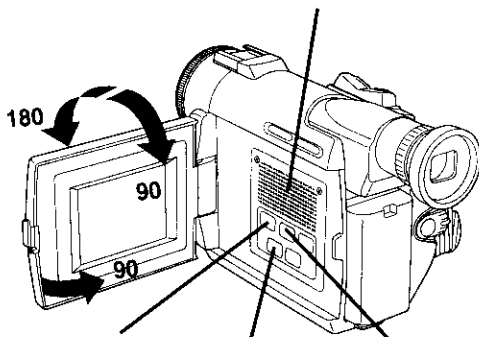

REWIND
SEARCH
Button

STOP
Button

PLAY
Button

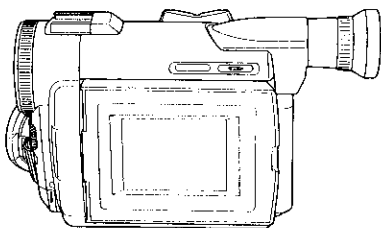

Before you begin...

- Connect the Palmcorder to a power source.
- Insert a recorded cassette.
- Set the Power Switch to VCR.

1 Press the **LCD-OPEN Button** to unlock the LCD monitor and swing open.

2 Press **REWIND/SEARCH** to rewind the tape.

3 Press **PLAY** to start playback.

To adjust the volume:

Hold down the **VOLUME WHEEL** until the volume setting screen appears. Then rotate the wheel to adjust the volume of the built-in speaker.

- Adjust the picture on the LCD monitor if needed. (see page 28)

4 Press **STOP** to stop playback.

- When the tape reaches its beginning during rewind or rewind search, it will stop automatically.
- If you press **PLAY** for more than 5 seconds, the Palmcorder will start the Repeat Playback mode when the tape reaches its end. The letter "R" will appear in the EVF. To exit the Repeat mode, turn the Palmcorder OFF.

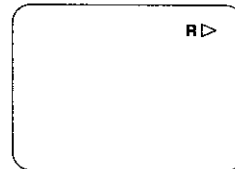

You can place the Palmcorder on a table, etc. for viewing. Rotate the LCD Monitor 180° and swing it up against the Palmcorder body as shown.

Note:

- When a tape recorded in LP mode on another digital video camera is played back on this unit, the picture may appear mosaic.
- Using the LCD monitor reduces battery operating time.

Playback Your Recordings

Special Effect Features During Playback

(Sound is muted during all special effects)

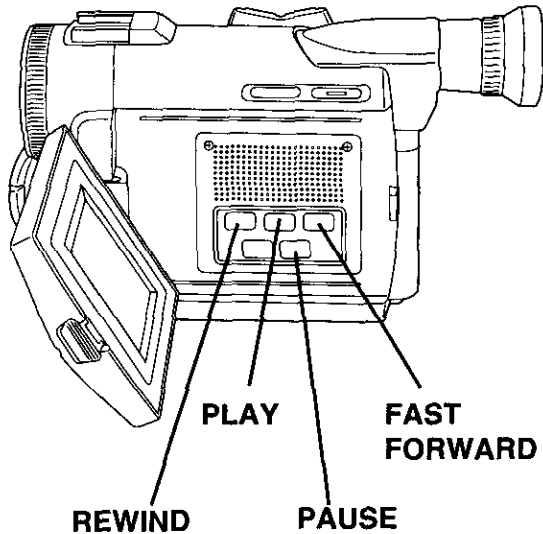

Rapid Visual Search

During playback, hold down **FAST FORWARD/SEARCH** or **REWIND/SEARCH** Buttons.

The search will continue for as long as the button is held down.

OR

Press **FAST FORWARD/SEARCH** or **REWIND/SEARCH** Buttons once for a continuous rapid visual search.

Press **PLAY** to release.

Note:

- When executing a rapid visual search, the picture may become bluish for an instant or mosaic. This is normal during this mode.

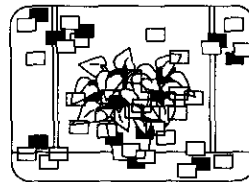

Basic Operation

STILL Picture

Press **PAUSE** during playback.

Press **PLAY** or **PAUSE** to release.

Note:

- To protect the tape and video heads, your Palmcorder's operating modes will revert as follows:
STILL → STANDBY after 5 minutes.

Optional

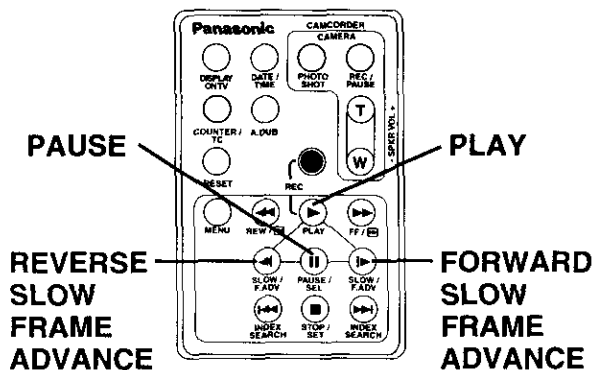

Slow Motion Playback

Optional Remote Control Only (page 53)

Forward Slow = Press **▶ SLOW/F.ADV** during play.

Reverse Slow = Press **◀ SLOW/F.ADV** during play.

Press **PLAY** to release. (During reverse slow motion playback, time code indication may not change regularly.)

Note:

- Palmcorder will automatically STOP when in slow motion for more than 10 minutes.
- During slow motion playback, picture may move up and down. This is normal.
- When you start or stop slow motion playback, the picture may become bluish for an instant.

Playback Your Recordings

Special Effect Features During Playback Continued

(Sound is Muted during all special effects)

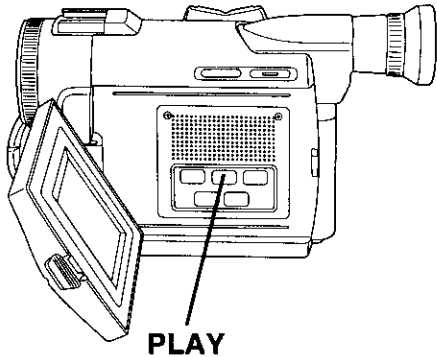

PLAY

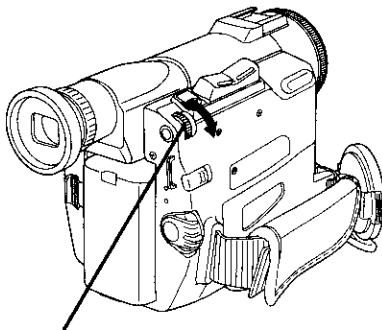

SET SELECT WHEEL

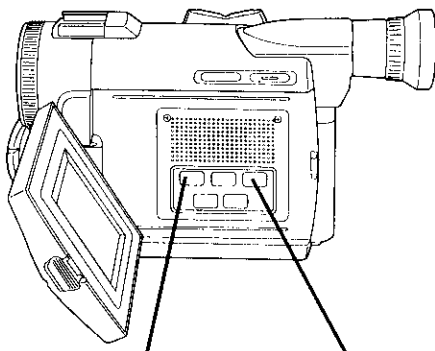

REWIND/
SEARCH

FAST FORWARD/
SEARCH

Variable Speed Search

- 1 Press the PLAY Button.**
 - Playback starts.
- 2 Press the PLAY Button again.**
- 3 Rotate the SELECT SET WHEEL to adjust the playback speed.**
 - Rotate the SELECT SET WHEEL downward for forward playback.
 - Rotate the SELECT SET WHEEL upward for reverse playback.

To return the normal playback:

Press the PLAY button. Playback continues at normal speed.

Notes:

- The Variable Speed Search function offers a choice of six playback speeds (1/5x, 1x, 2x, 5x, 10x, 20x) both in forward and reverse directions.
- The review playback at the 1x speed is playback in reverse direction.
- During the Variable Speed Search (at a speed other than 1x), mosaic-like patterns will appear in the picture.
- During the Variable Speed Search, sound is muted.

Fast Forward/Rewind Check

Monitor normal picture playback during fast forward or rewind.

- **Hold down the FAST FORWARD/SEARCH** during fast forward.
- **Hold down the REWIND/SEARCH** during rewind.
- The picture will appear for as long as the button is held down.

Playback Your Recordings

Special Effect Features During Playback Continued

(Sound is Muted during all special effects)

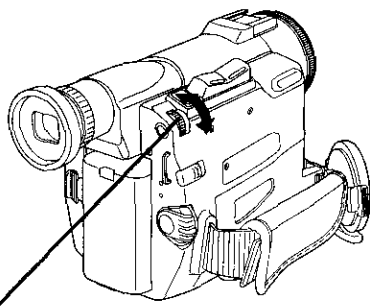
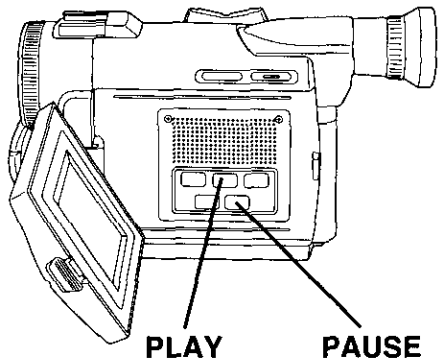

SELECT SET WHEEL

Optional

REVERSE SLOW FRAME ADVANCE

INDEX SEARCH (rewind)

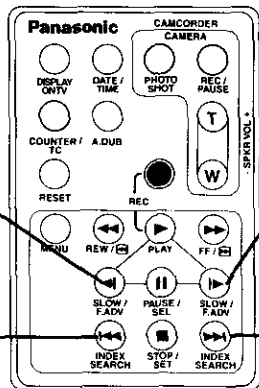

FORWARD SLOW FRAME ADVANCE

INDEX SEARCH (fast forward)

Top Scan

If you hold down the INDEX SEARCH button more than 2 seconds, the Palmcorder will scan for scenes (or photo shots) and playback the first few seconds of each.

To cancel this function, press PLAY or STOP.

Frame by Frame Advance

Optional Remote Control Only (page 53)

Press PAUSE during playback.

Press ► SLOW/F.ADV to do a frame by frame advance.

Press ◀ SLOW/F.ADV to do a frame by frame reverse.

Press PLAY to release.

Note:

- If you hold down SLOW/F.ADV, you can see a continuous series of still images at a slower speed than normal slow mode.
- During frame by frame advance, a few frames may move automatically, and the picture may become bluish for an instant.

Jog Frame by Frame Search

(Palmcorder only)

During Still mode, rotate the SELECT SET WHEEL to advance or reverse the picture one frame at a time.

Index Forward/Reverse Search

Optional Remote Control Only (page 53)

Search for a particular scene by using the electronic index marks placed at the beginning of each recording. (See page 18 for details on the two different kinds of index marks.)

1 Place the Palmcorder in the VCR STOP mode.

2 Press the INDEX SEARCH fast forward or rewind Buttons the number of recordings (indexes) forward or back you want to view. The Palmcorder will advance or rewind to the desired recording and automatically PLAY.

- The number of times you press the button is displayed in the EVF and the LCD monitor if you set INDEX on the VCR menu to SCENE (see page 19). (Ex., if you press the button three times, "S3" will appear.)

• If the interval between scenes is less than 1 minute, index search may not operate properly.

• Response time between pressing the button and change in the scene number is quite slow. Do not press the INDEX SEARCH Button rapidly and continuously.

• It won't playback when the tape reached beginning during Reverse Index Search mode.

Basic Operation

Playback Your Recordings

Attach the Jack Box for TV Viewing

Your Palmcorder may be connected to a TV to play back tapes or to view what you are recording by connecting to the Jack Box.

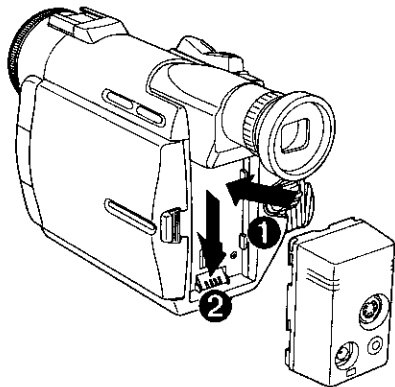

Before you begin...

- Connect the Palmcorder to your TV as illustrated on next page.

IMPORTANT:

Turn off the Palmcorder before connecting to a power source.

Insert the Jack Box and slide it down until it locks with a click.

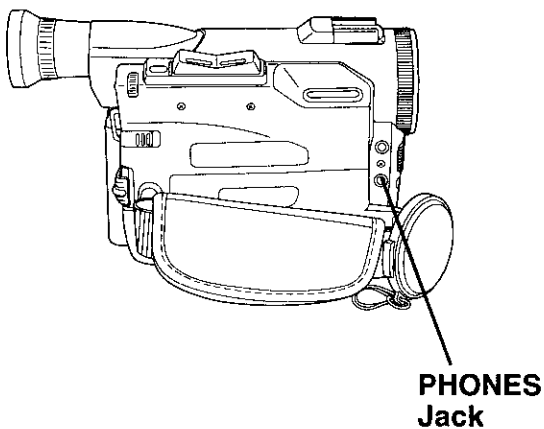

Note:

- Use an AC Adaptor PV-DAC9 (included) so that you do not have to worry about depleting the battery.
- Connect earphones (not supplied) to the PHONES jack.
- When earphone (M3 type: not supplied) is connected to PHONES jack, speaker is muted.

Playback Your Recordings

Connections

TV with AUDIO/VIDEO IN Jacks.

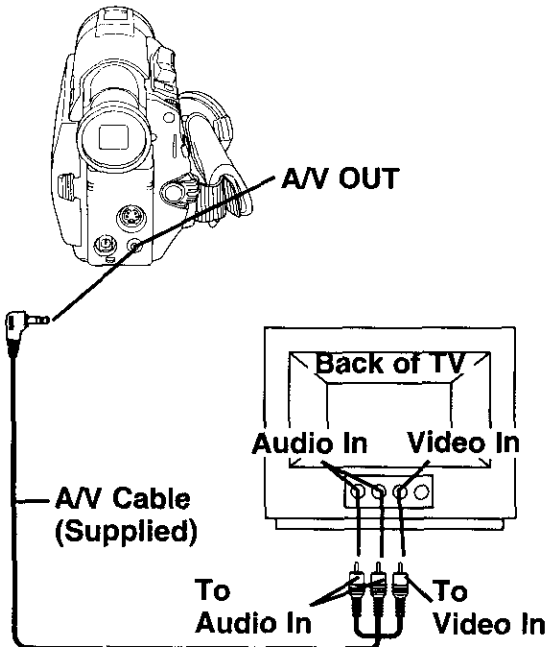

- 1** Set the **POWER Switch** to **CAMERA**. You can now view what the Palmcorder is recording on your TV.
Or, to playback a tape, set the **POWER Switch** to **VCR**. You can now playback a recorded tape on your TV.

- 2** Turn your TV **ON** and set it to **LINE INPUT** or **S-VIDEO**. Check your TV operating instructions for further information.

- 3** Start playback or begin a recording.

Note:

- Please connect the A/V cable until it stops.
- Make sure the Palmcorder and TV are turned off while connecting.

Basic Operation

TV with S-VIDEO IN Jacks.

For best Chrominance and Luminance it is suggested to use the S-Video connection if available on your TV.

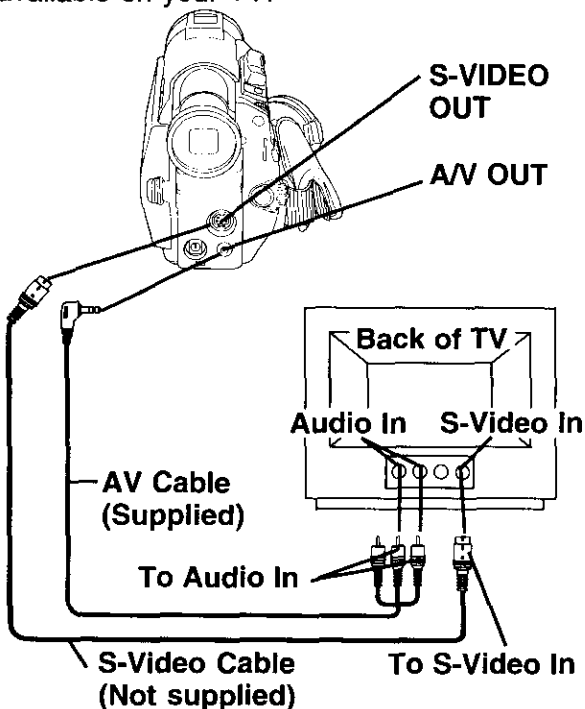

Optional Remote Control Only (page 53)

You can display the various EVF indications on your TV by pressing **DISPLAY ON TV** on remote control. Press again to remove the indications.

DISPLAY ON TV

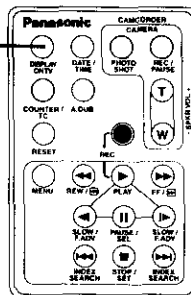

Optional

CATV System Installer

This reminder is provided to call the CATV system installer's attention to Article 820-40 of the NEC in USA (and to the Canadian Electrical code in Canada) that provides guidelines for proper grounding and, in particular, specifies that the cable ground shall be connected to the grounding system of the building, as close to the point of cable entry as practical.

Special Features

Digital Electronic Image Stabilization System (D.E.I.S.)

This feature helps stabilize the picture in situations such as walking or shooting from a moving vehicle.

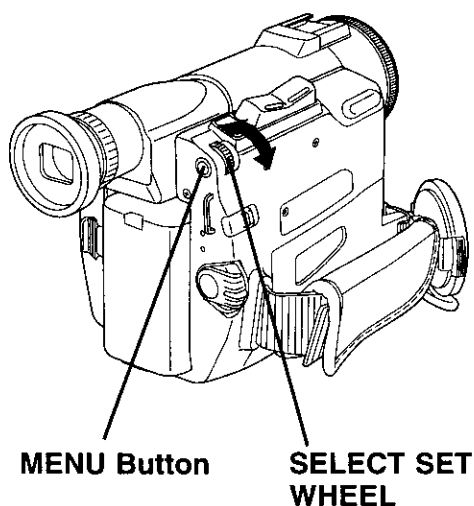
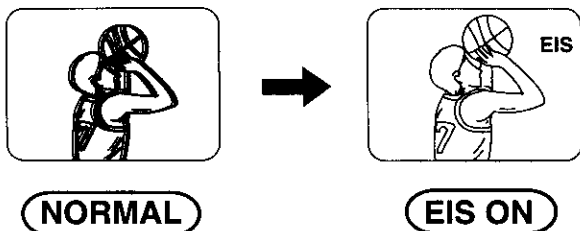

Before you begin...

- Set the POWER Switch to CAMERA.

1 Press **MENU Button** to display the menu screen.

2 Rotate and press the **SELECT SET WHEEL** to select EIS from D.FUNCTION (page 17).

- Picture flicker may be observed when taping under fluorescent lighting conditions.
- Turn D.E.I.S. OFF during recording when using a tripod.

3 Set **EIS OFF** to cancel.

- Be sure that the D.E.I.S. is turned off when not needed.

D.E.I.S. may not function when...

- Palmcorder movement is too extreme.
- Recording a subject with distinct horizontal or vertical stripes.
- Recording in low light situations.
- Recording a subject under a great amount of fluorescent light.
- Recording a scene with very fast motions.

Special Features

Zoom

You can gradually zoom in for close ups or zoom out for wide angle shots.

The zooming speed ranges from a slow 22 seconds to a fast 2 seconds according to the amount of pressure applied to the zoom buttons.

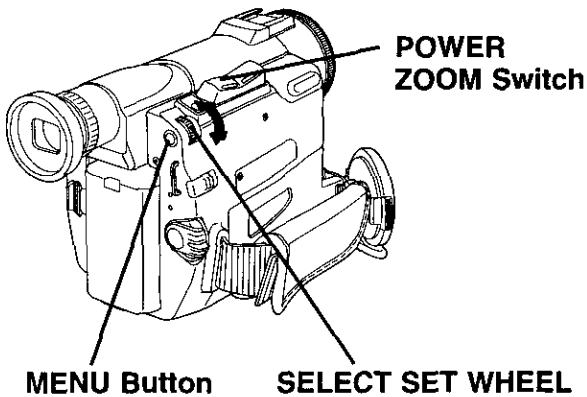

Zoom slowly by lightly moving the power zoom switch toward the "T" (Telephoto) or the "W" (Wide Angle).

Zoom quickly by applying more pressure.

Digital Zoom

To enable this feature: Display the CAMERA mode menu (see page 17). Rotate the SELECT SET Wheel to select D.FUNCTION and press down on the SELECT SET WHEEL to select EIS/D.ZOOM or D.ZOOM.

Then, rotate the SELECT SET WHEEL to select D. ZOOM. Press down on the SELECT SET WHEEL to select 36x (D.ZOOM1) or 300x (D.ZOOM2).

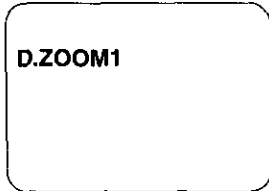

Zoom In ("T")

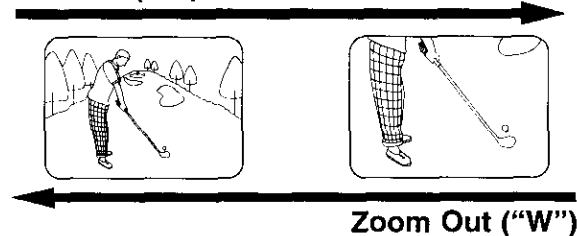

- The normal optical zoom functions from 1x to 18x.
- D.ZOOM1 functions from 18x to 36x. D.ZOOM2 functions from 18x to 300x.
- The magnification level is displayed in the EVF or the LCD monitor while pressing the POWER ZOOM Switch.
- Because the image is enlarged digitally, the picture may become distorted when higher magnification levels are used.
- When the level falls below 18x, the normal zooming function will resume.
- Focus length becomes 4 feet (1.2m) if the lens is in full telephoto.

Special Features

Recording Still Pictures

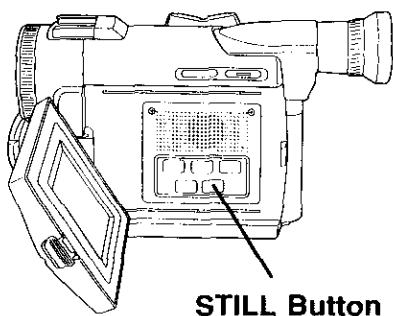

You can record still pictures of any desired duration together with sound.

1 While in RECORD mode, **press STILL Button once** to capture still picture. The captured still picture will be recorded together with the sound.

2 **Press STILL Button once again** to release the still picture. The camera will resume recording real-time pictures and sound.

Special Features

Digital Photo Shot

Use this feature to record a seven second (approx.) still image from the current camera picture. Audio is also recorded for on the spot narration. Or, you can add narration later with the Audio Dubbing feature to make an interesting slide show, etc. (page 47).

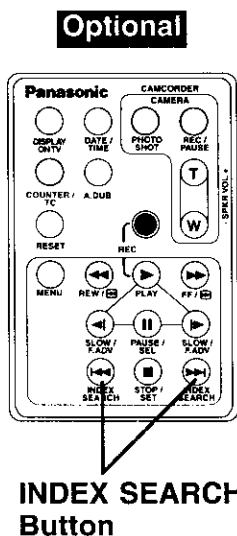
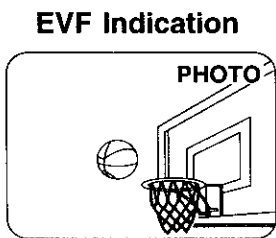
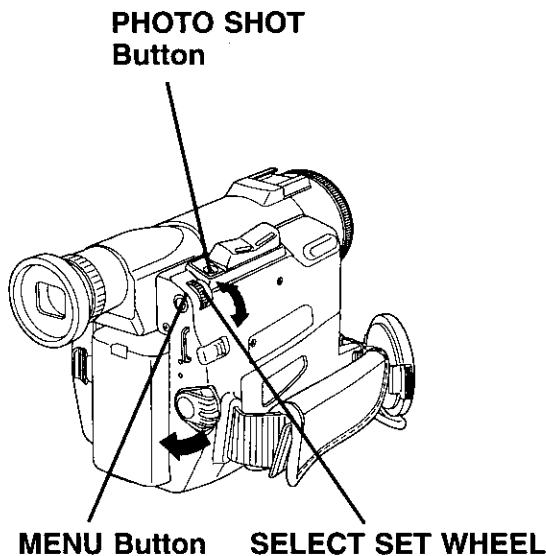

Before you begin...

- Set the POWER Switch to CAMERA.

- 1 Press **PHOTO SHOT** Button in Record/Pause mode. "PHOTO" will appear in the EVF or the LCD monitor.
 - If SHUTTER on the menu screen is set to ON, a sound effect similar to the shutter of a film camera will be heard when the PHOTO SHOT Button is pressed.

Optional Remote Control Only (page 53)

- 2 Set the POWER Switch to VCR.
- 3 Press **MENU** to display the VCR mode menu screen in the EVF or the LCD monitor.
- 4 Rotate the **SELECT SET WHEEL** to select INDEX and press down to select PHOTO.
- 5 Press one of the **INDEX SEARCH Buttons** on the remote control (Optional, page 53) to advance or rewind the tape to playback a photo shot scene.
 - To view the next photo shot, the INDEX SEARCH Button must be pressed again.

Note:

- The picture quality will deteriorate slightly.
- The tape remaining indicator will not appear while PHOTO SHOT feature is used.
- When the AUDIO-REC mode is changed, the shutter sound effect may not be able to be heard even when SHUTTER is set to on.

Special Features

White Balance

Auto White Balance automatically maintains optimum color balance in most lighting conditions. However, when using Digital Functions, etc., you may get better results using the manual adjustment.

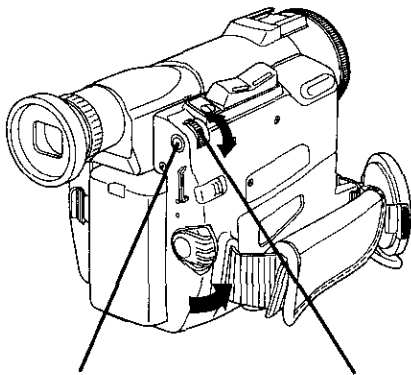

MENU Button

SELECT SET WHEEL

Before you begin...

- Set the POWER switch to CAMERA.

- 1** Press MENU Button to display the menu screen.
- 2** Rotate the SELECT SET WHEEL to select W.BALANCE, and then press down on the SELECT SET WHEEL repeatedly to select either AUTO, Indoor halogen lamp "☀", Outdoors "☀☀" or Indoor fluorescent lamp "☀☀☀".

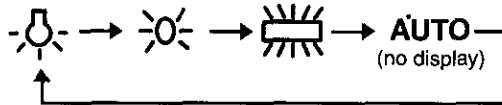

- ☀ : When the source illumination is a halogen lamp.
- ☀☀ : When shooting outdoors on a sunny day.
- ☀☀☀ : When the source of illumination is a fluorescent lamp.
- AUTO : Automatically maintains optimum color balance in most lighting conditions.

Special Features

Special Features

Program AE

The Auto Exposure feature can be used to make quality recordings in a variety of scene situations.

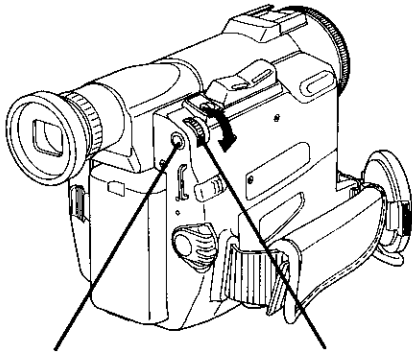

MENU Button SELECT SET WHEEL

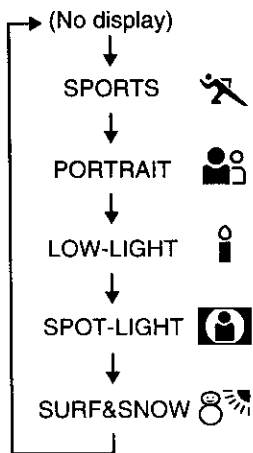

1 Press **MENU** to display the menu screen and rotate the **SELECT SET WHEEL** to select one of the five modes shown below.

2 Press **MENU** to display the menu screen and rotate the **SELECT SET WHEEL** to select no display to cancel this feature.

Sports mode

For recording fast action scenes.

Portrait mode

For recording only subjects in the foreground, while ignoring subjects in the background.

Low-light mode

For recording in extreme low light conditions.

Spot-light mode

Recording in situations where subjects are under a spotlight(s).

Surf & Snow mode

For recording in locations with a high degree of "Dazzle", such as snow slopes and the seashore.

Note:

SPORTS mode

- The recorded images will not be so blurred when they are viewed later using slow or still picture playback.
- When playing back a sports mode recording, the movement may appear slightly jerky.
- Do not use this mode when recording under fluorescent, mercury or sodium lighting. These types of lights will affect the color and brightness of the images.
- A vertical band of light might appear when recording objects that are brightly illuminated or which are highly reflective.
- If the amount of light is insufficient, the SPORTS "⚡" indicator will flash in the EVF or the LCD monitor.
- The image may flicker if this mode is used indoors.

PORTRAIT mode

- The image may flicker if this mode is used indoors.

LOW-LIGHT mode

- Scenes recorded in extremely low light levels may not come out properly.

SPOT-LIGHT mode

- If the recorded subject is extremely bright, the picture may appear whitish.

SURF&SNOW mode

- If the recorded subject is extremely bright, the picture may appear whitish.
- If you selected GAIN UP in the Digital function camera menu, SPORTS mode and PORTRAIT mode can not be selected.

Special Features

Digital Functions

Use the following features to add interest and professionalism to your recordings. Select from nine special effects.

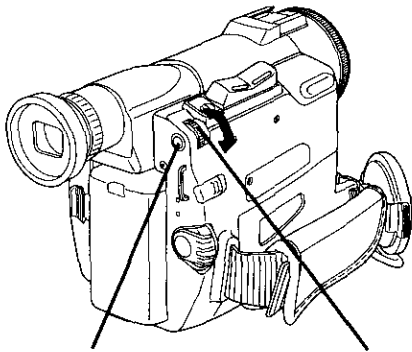

MENU Button SELECT SET WHEEL

Types of Digital Effects

WIPE

Successive scenes are separated in a way which simulates the drawing of a curtain.

MIX

The current scene is mixed in with the following scene during scene changes.

STROBE

The recording appears as a sequence of still frames.

GAIN UP

Picture sensitivity is increased.

- Only Manual Focus is available.

TRAIL

The subject being recorded creates a trail when in motion.

NEGA (Neg/Pos)

The recorded picture is inverted to appear as a film negative.

SEPIA

The picture is recorded in sepia, brownish color, giving it an antique look.

MONO (Monotone)

The picture is recorded in black-and-white.

SOLARI (Solarization)

The scene takes on a appearance similar to an oil painting.

- 1** In Camera mode, press MENU to display the menu screen.
- 2** Rotate the SELECT SET WHEEL to select D.FUNCTION or D.EFFECT. Then, press down on the SELECT SET WHEEL repeatedly to select one of the Digital Functions listed below.
- 3** To cancel the Digital Function, press down on the SELECT SET WHEEL to select OFF.

Note:

- The EIS and Digital Zoom features must be turned off in order to use Digital Functions.

To use the WIPE:

- a. In Camera mode, set the "D.FUNCTION" item in the menu screen to "WIPE" (page 17).
- b. Press the RECORD/PAUSE to start recording.
- c. Press the RECORD/PAUSE to pause the recording. The last scene will be memorized.
- d. Press the RECORD/PAUSE to start recording again. The new scene will take the place of the memorized scene.

To use the MIX:

Perform steps a-d above. The memorized scene and the new scene will appear mixed as the scene changes from one to the other.

Special Features

Auto Focus

The Palmcorder automatically adjusts the focus over the entire zoom range.

Manual Focus

Use Manual Focus (MF) when recording ...

- a subject through glass.
- a scene where the subject is far from the Palmcorder and there are objects in the foreground.
- a subject with distinct horizontal stripes.
- a subject not centered in the Viewfinder.
- subjects with shiny surfaces.
- an obliquely angled subject.
- a bright, flat subject such as a white wall.
- in low light situations.
- a scene with fast motions, like a golf swing.
- **Re-focusing may be required** when your Palmcorder is aimed at a new scene.

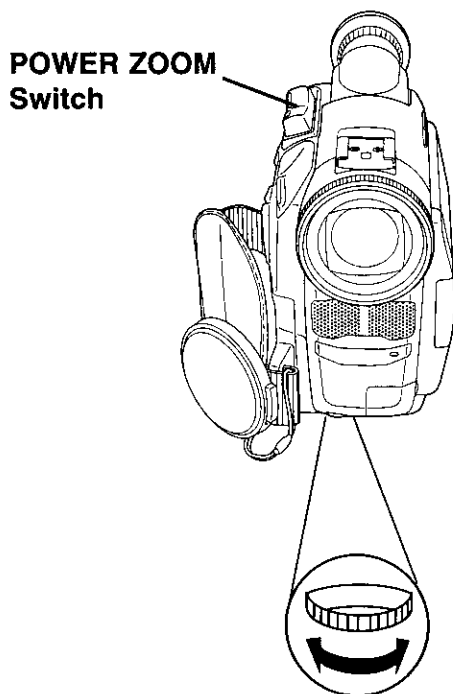

- 1** Press **MANUAL FOCUS** so that "MF" (Manual Focus) appears in the EVF or the LCD monitor.

EVF/LCD Monitor

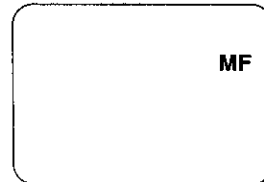

- 2** Press and hold the **POWER ZOOM Switch** to the "T" side (Full Telephoto) until the lens is zoomed in all the way (subject at maximum size).

- 3** Turn the **MANUAL FOCUS** control until the picture is in focus.
 - It may be necessary to back away from the subject to focus the image properly.

- 4** Press the **POWER ZOOM** switch to "W" or "T" as desired.
 - The subject will remain in focus over the entire zooming range.
 - It may be necessary to back away from the subject to focus the image properly.

Macro Focus (for close-ups)

Press the "W" side of the **POWER ZOOM** Switch to the wide angle position.

Auto Focus will function with the subject as close as 1 inch (25mm) in front of the lens.

Special Features

Audio/Video Fade In/Out

This feature allows you to make smoother scene transitions for a more professional look.

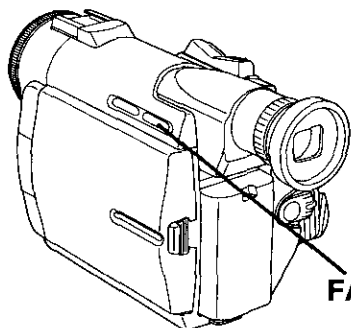

FADE Button

Fade In:

Starting the first scene with "fade in" is very effective.

In Record/Pause mode, hold down FADE until the picture and sound fade out.

Then, press RECORD/PAUSE to start recording.

Release FADE and the picture and sound will gradually fade in.

Fade Out:

Use to create a soft ending or (together with fade in) for a soft transition from one scene to the next.

During recording, hold down FADE until the picture and sound fade out.

Then, press RECORD/PAUSE to pause the recording.

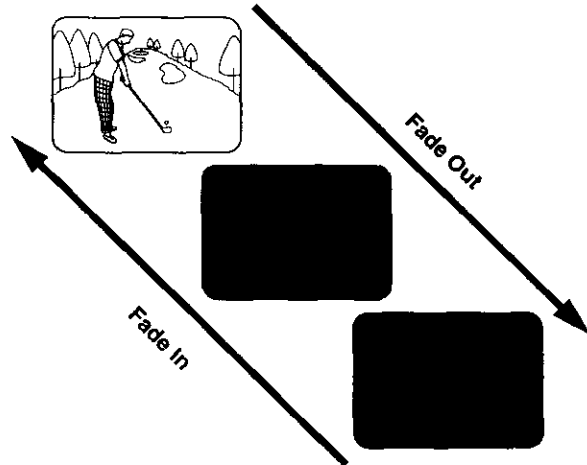

Backlight

Use when recording a subject that is darker than the surrounding scene, in a shadowed area, or when the light source is in the back of your subject.

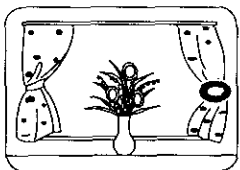
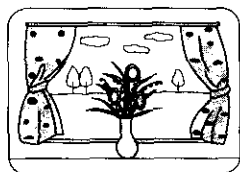

EVF or LCD monitor indication.

Press the **BACK LIGHT Button** to activate the Backlight feature.

The Indicator "●" will appear in the EVF or LCD monitor.

Press the **BACK LIGHT Button again** to cancel the Backlight feature.

BACK LIGHT Button

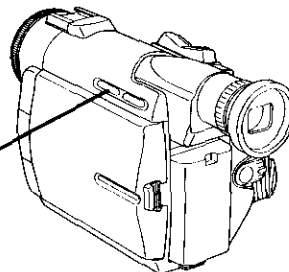

Note:

- The Indicator "●" will not appear in the EVF or LCD monitor when OFF is selected in the DISPLAY menu.

Special Features

Special Features

High Speed Shutter

To record high speed motion (e.g. a tennis stroke) for improved STILL or SLOW MOTION playback, when watching the tape on this Camcorder.

Before you begin...

- Connect the Camcorder to a power source.
- Set the POWER Switch to CAMERA.
- Insert a cassette with record tab (see page 14).

Auto Shutter

In the AUTO mode (no indication in the EVF), the Camcorder will automatically adjust the shutter speed (1/100).

- AUTO mode is automatically selected whenever the POWER Switch is set to CAMERA.

Manual Selection

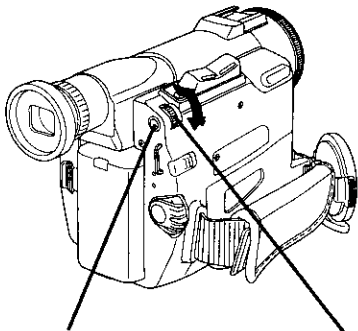

MENU Button SELECT SET WHEEL

1 Press **MENU** to display the camera mode menu in the EVF or the LCD monitor.

2 Rotate the **SELECT SET WHEEL** to select **SHUTTER**, and then press down on the **SELECT SET WHEEL** to **SET**.

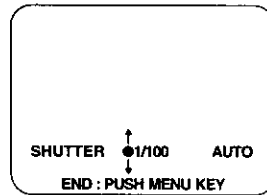

3 Rotate the **SELECT SET WHEEL** to obtain one of the following shutter speeds.

Note:

- For proper color reproduction, it is recommended that you use this feature outdoors. For indoor High Speed Shutter recording, additional halogen or tungsten light should be provided. Fluorescent light will degrade the picture quality.
- This feature requires ample light. More light is required for the fastest shutter speeds.
- The Auto Focus system may not operate properly in insufficient light when using the High Speed Shutter.

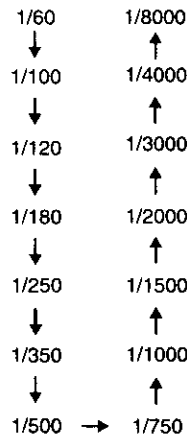

Special Features

Audio Dubbing using the External or Built-in Microphone (Optional Remote Control Only)

The original sound can be replaced with new sound using the built-in Palmcorder microphone or an external microphone.

The AUDIO-REC setting in CAMERA MENU mode should be as follows:

12bit The original sound is recorded on ST (Stereo) 1, and the new sound will be recorded on ST (Stereo) 2.

16bit The original sound is replaced with the new sound.

- Select 12bit if you do not want the original sound to be completely replaced during an audio dub.
- If you dub over a tape which has both 12bit and 16bit audio recordings on it, keep in mind that the original 16bit audio portion will be completely replaced.

Before you begin...

- Connect the external Microphone (if used).
- Turn On the Palmcorder.
- Insert a pre-recorded tape to be dubbed.

External Microphone with M3 connector (not supplied)

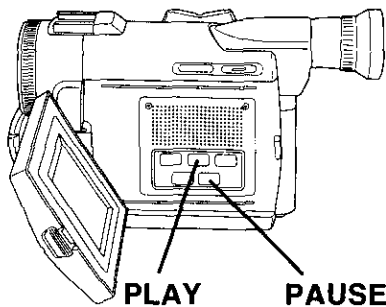
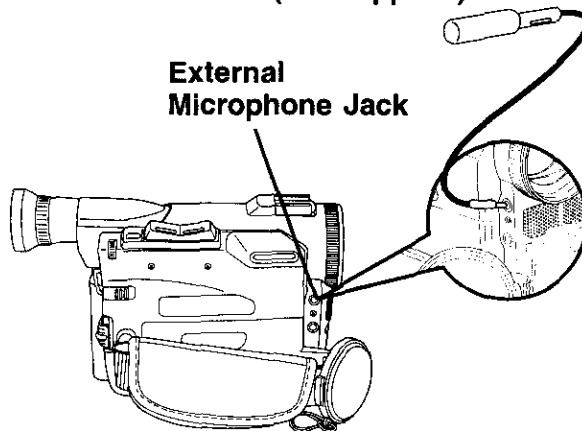

1 Set the POWER switch to VCR.

2 Press PLAY.
Then press PAUSE where you want dubbing to begin.

3 Press A.DUB on the remote control (Optional, page 53) to put the Palmcorder in the Audio Dub mode.

Special Features

Optional

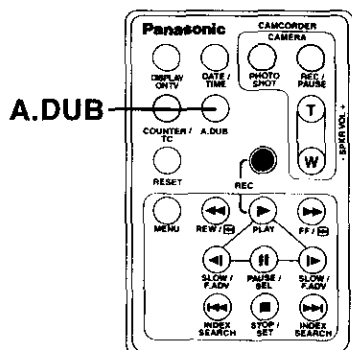

EVF Indication

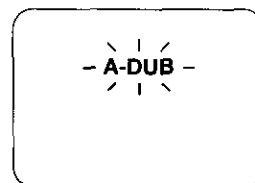

(Continued on next page.)

Special Features

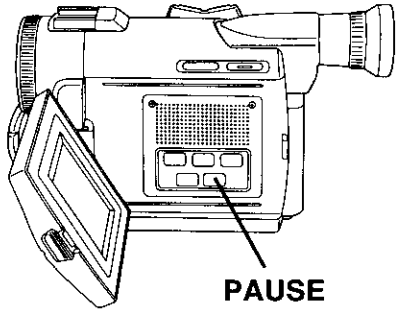

To listen to the desired audio sound, set the AUDIO setting of the VCR mode MENU (page 19) as follows:

AUDIO (The following selections are available 12bit AUDIO dubbed recording only)

- ST1** Set this position to listen to the original sound.
- ST2** Set this position to listen to the audio dubbed sound.
- MIX** Set this position to listen to both the original sound and the audio dubbed sound.

Note:

- 16bit dubbed sound completely erases the original 16bit recorded sound.
- If you select 12bit AUDIO recording and dubbed the sound with the AUDIO-MIX on, the sound will be stereo regardless of the AUDIO-OUT setting.
- If you recorded in LP mode, you can not use the A-DUB feature.

4 Press **PAUSE** to start Audio Dubbing. Connect Palmcorder to TV in order to monitor the sound. (see page 37)

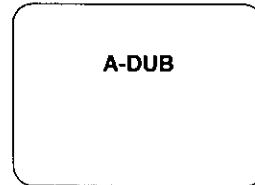

Only NTSC (National Television Standards Committee) recorded tapes can be audio dubbed. The following screen appears if the tape was not recorded in NTSC format.

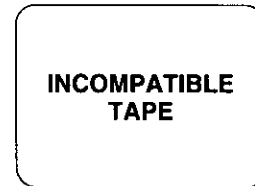

5 Press **PAUSE** to stop Audio Dubbing.

Memory-Stop Editing (Optional Remote Control Only)

You can set an automatic Edit stopping point.

Before step 2, locate the point at which you want the dubbing to stop.

Press MENU and set **DISPLAY** to **MEMORY** (page 18).

Then, press RESET on the remote control to reset the Counter Memory to M 0:00:00.

Now, rewind to the editing start point, and continue with steps 2-5. The tape will now stop automatically at "M 0:00:00".

Optional

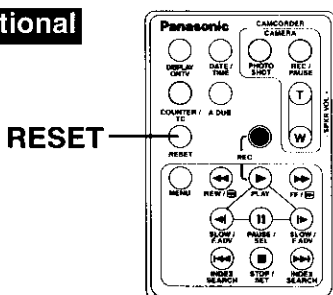

Special Features

Copying your Tapes to S-VHS or VHS Cassette

Before you begin...

- Connect the Palmcorder and the Jack Box (see page 36).
- Connect both Palmcorder and VCR to their power sources.
- Connect the Palmcorder to a VCR as illustrated below.
- Turn ON both units.
- **Set the recording VCR's Input Signal Selector to LINE.**
- Set the Palmcorder POWER Switch to VCR.

1 Insert a pre-recorded tape into the source (playing) Palmcorder and a blank tape with record tab in place into the target VCR (Recorder).

2 Press **PLAY** on the Palmcorder. When the tape reaches the point you want to start dubbing, press **PAUSE**.

3 Press **REC** or simultaneously **REC** and **PLAY** (depends on VCR) and then pause the recorder.



VCR Buttons

4 Simultaneously, press **PAUSE** on both units to begin the copying.

5 Press **STOP** on both units when copying is complete.

Notes:

- For technical reasons, dubbing a tape may reduce its quality.
- Press **DISPLAY** on the Palmcorder remote control to eliminate EVF/LCD Monitor indications to be recorded on the tape. Eliminate all OSD functions on the VCR as well.
- If the Time Code is displayed in the EVF or LCD monitor, this display cannot be reset.

CAUTION:

Unauthorized exchanging and/or copying of copyrighted recordings may be copyright infringement.

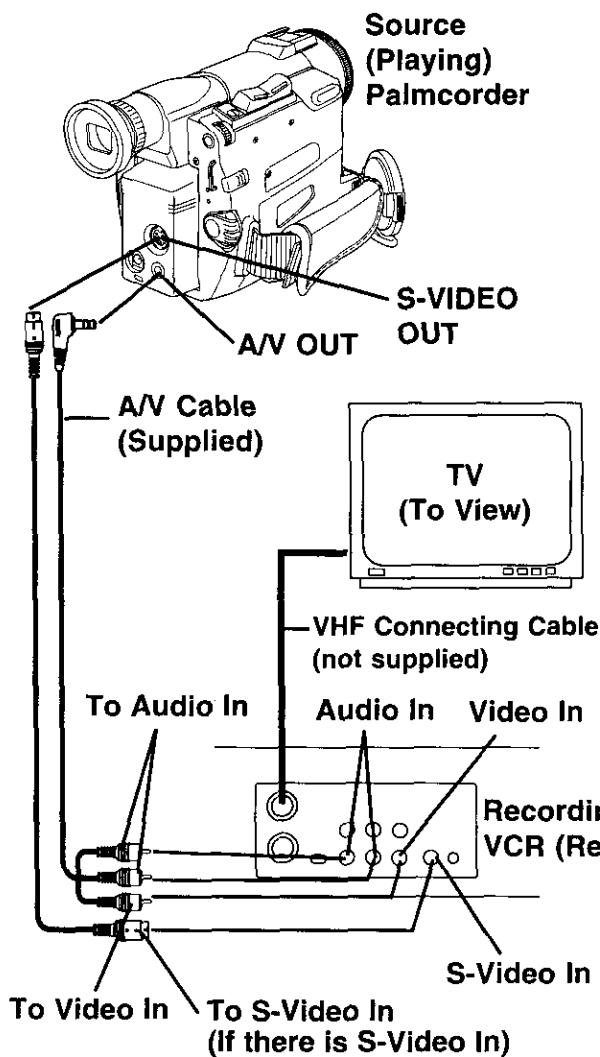

Monitor with your TV

- Turn the TV ON and select its VCR channel (either CH3 or CH4).
- Set the VCR/TV Selector on the recording VCR to VCR.

Special Features

Special Features

Copying from Digital Equipment (dubbing) (Optional Remote Control Only)

High quality digital-to-digital copying can be accomplished if both Palmcorders incorporate the digital in/out IEEE1394 interface (DV interface cable is not supplied).

Before you begin...

- Connect both Palmcorders to their power sources.
- Connect the two digital Palmcorders using the DV interface cable (not supplied).
- Turn both Palmcorders ON.

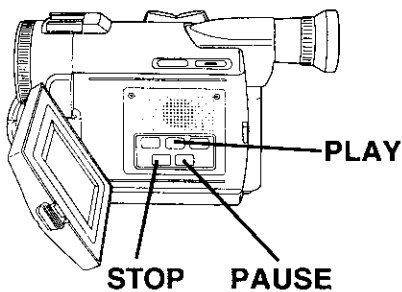
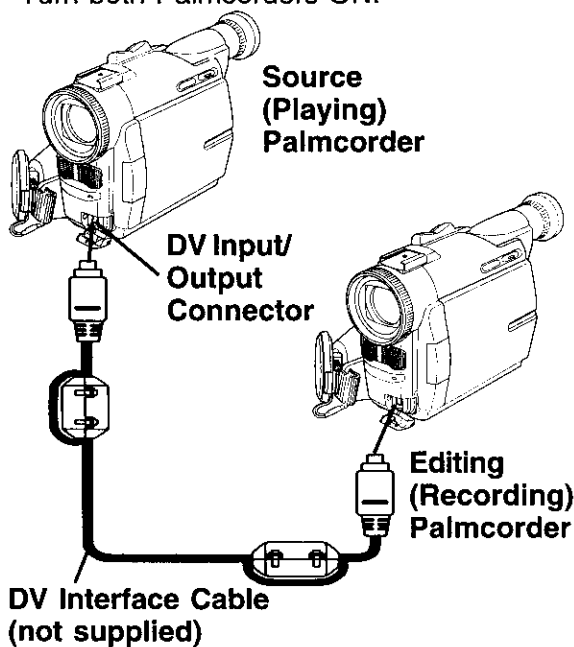

Optional

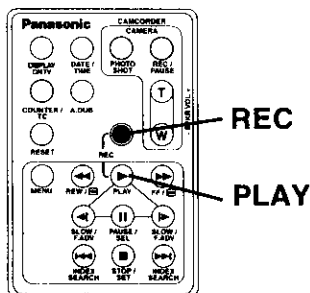

- 1** Insert a pre-recorded tape into the source (playing) Palmcorder, turn on, and set the **POWER Switch** to **VCR**.
- 2** Insert a blank tape with the record tab in place into the target (recording) Palmcorder turn on, and set the **POWER Switch** to **VCR**.
- 3** Press **PLAY** on the source Palmcorder. When the tape reaches the point you want to start dubbing, press **PAUSE**.
- 4** On the remote control (Optional, page 53), hold down the **REC** button and press **PLAY**. Press **PAUSE** to pause the tape at the starting point of the dub.
- 5** Simultaneously, press the **PAUSE** Buttons on both units to begin the dubbing.
- 6** Press the **STOP** Button on recording unit, and then press **STOP** Button on playing unit to end dubbing.

Note:

- When two Palmcorders are used for dubbing, it is recommend that the remote control VCR1 or VCR2 setting be used to avoid mis-operation.
- When two Palmcorders are connected using the DV interface cable (not supplied), a Video Editing Controller cannot be used.

CAUTION:

Unauthorized exchanging and/or copying of copyrighted recordings may be copyright infringement.

Special Features

PC Connection

A live image can be transferred directly to your PC (Personal Computer) via a DV Interface Cable (not supplied) using products from Adaptec or Digital Origin (formerly Radius).

Using these products allows you to capture live images onto your PC, edit the captured image, etc.

Note:

- For more detailed information, please see the Adaptec and Digital Origin (formerly Radius) brochures in this box or visit their web site at:

<http://www.adaptec.com/1394> or

<http://www.digitalorigin.com/DVP>

- For assistance on Adaptec products, call **1-800-442-7274**
For assistance on Digital Origin (formerly Radius) products, call **1-800-572-3487**

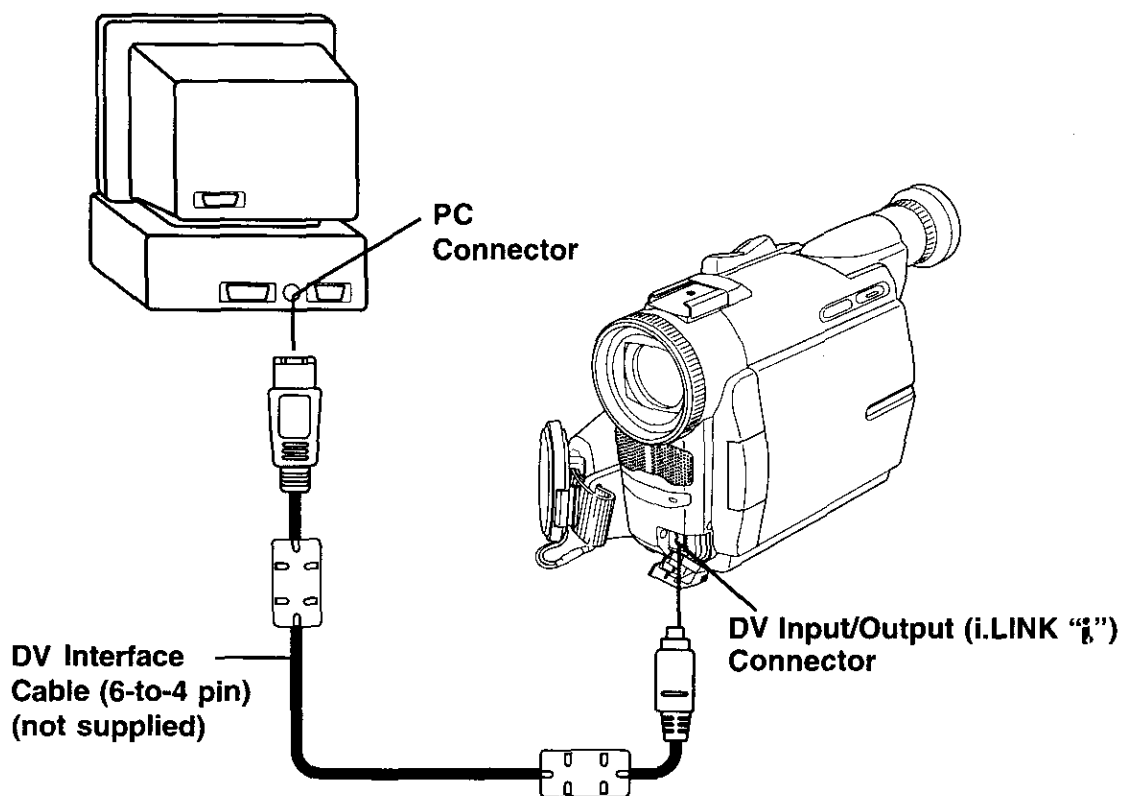

Special Features

Special Features

Using the Digital Photo Printer

Images can be selected for print out on a digital photo printer (sold separately).

Before you begin...

- Connect both Palmcorder and Digital Photo Printer to their power sources.
- Connect the Palmcorder and Digital Photo Printer using a A/V cable (supplied) or S-Video Cable (not supplied).
- Connect the Digital Photo Printer and your TV using a Video cable (not supplied) and turn the TV on.
- If different video sources are connected simultaneously to the S-VIDEO IN Socket and the VIDEO IN Socket, the video for S-VIDEO IN Socket takes precedence.
- To listen to sound from the Palmcorder, connect the audio output from the Palmcorder directly to the television AUDIO IN socket.
- Please refer to the printer's operating instructions for detail on printing.

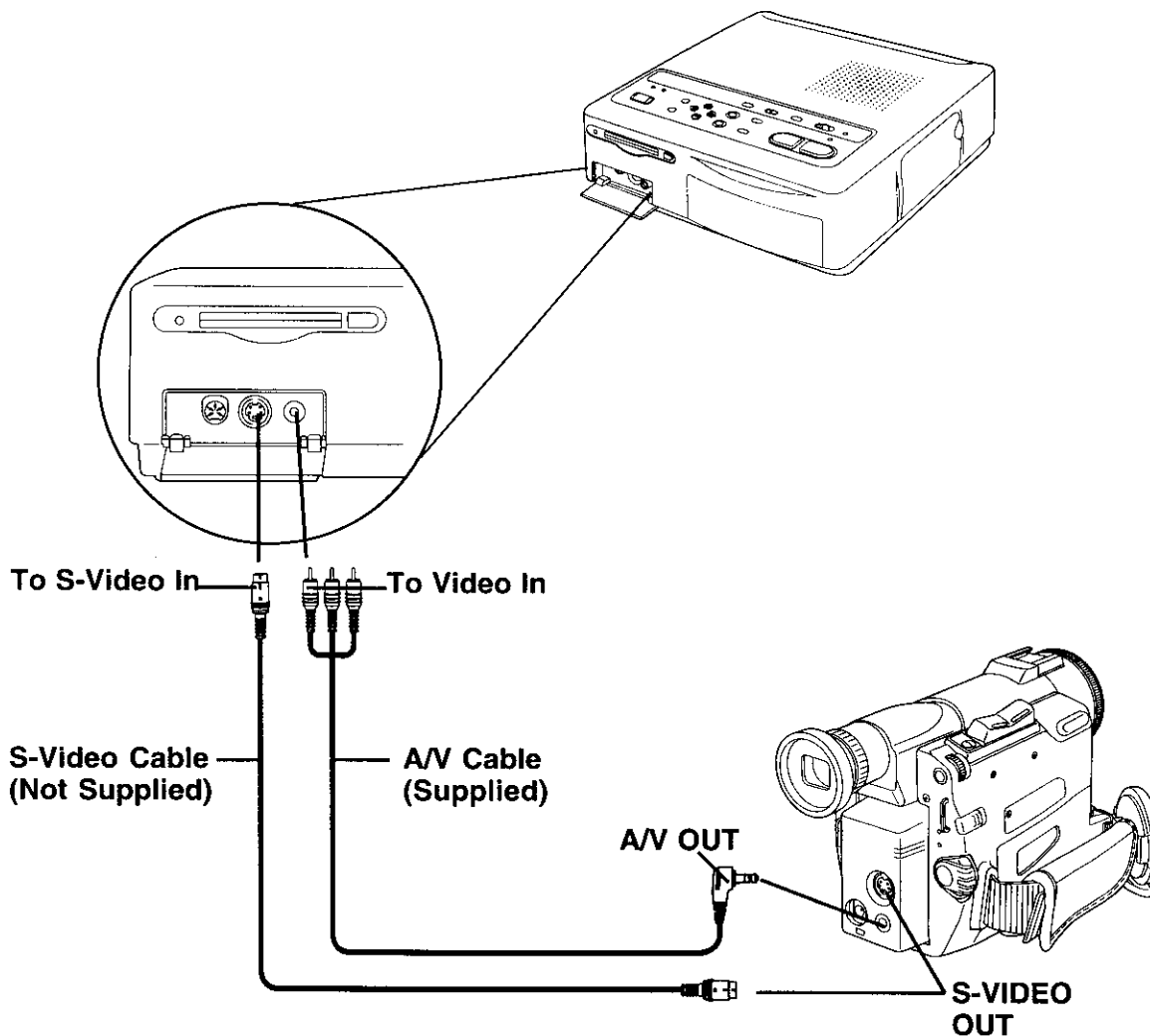

Palmcorder Accessory System

For ordering instructions, see the Accessory Order Form page.

Accessory #	Figure	Description	Price
PV-DAC9		AC Adaptor with AC Cable, DC Cable and Jack Box	\$140.00
CGR-D120A/1B (Same as PV-DBP8)		800mAH / 1 h 15 min Battery Pack	\$60.00
CGR-D220A/1B		1600mAH / 2 h 50 min Battery Pack	\$100.00
CGR-D815A/1B		5300mAH / 9 h Battery Pack	\$200.00
PV-DDC9		DV Interface Cable	\$45.00
PV-DLT9		Color Enhancement Light	\$ 39.95
PV-DRC9		Remote Control	\$ 29.95
PV-H200		Carrying Case	\$49.95
PV-H210			\$99.95

For Your Information

Palmcorder Accessory Order Form

Please photocopy this form when placing an order.

1. Palmcorder Model # _____

2. Items Ordered

Accessory #	Description	Price Each	Quantity	Total Price
Subtotal				
Your State & Local Sales Tax				
Shipping & Handling				5.00
Total Enclosed				

3. Method of payment (check one)

- Check of Money Order enclosed (NO C.O.D.SHIPMENTS)
- VISA Credit Card # _____
- MasterCard Expiration Date _____
- Discover Customer Signature _____

Make Check or Money Order to: MATSUSHITA ACCESSORIES

(Please do not send cash)

4. Shipping information (UPS delivery requires complete street address)

Ship To:
 Mr. _____
 Mrs. _____
 Ms. _____

First _____ Last _____ Phone #: _____
 Day () _____

Street Address _____
 Night () _____

City _____ State _____ Zip _____

TO OBTAIN ANY OF OUR OMNIMOVIE/PALMCORDER ACCESSORIES YOU CAN DO ANY OF THE FOLLOWING:

VISIT YOUR LOCAL PANASONIC DEALER
 OR
 CALL PANASONIC'S ACCESSORY ORDER LINE AT 1-800-332-5368
 [6 AM-5 PM M-F, 6 AM-10:30 AM SAT, PACIFIC TIME]
 OR
 MAIL THIS ORDER TO: PANASONIC SERVICES COMPANY ACCESSORY ORDER OFFICE
 20421 84th Avenue South Kent, WA. 98032

Notes On Operations

Attaching Optional Filters and Lenses

When you remove the Lens Hood, pinch the Lens Hood and turn it counterclockwise.

Then attach an optional filter or lens.

- Be careful not to touch the lens itself.
- Replace the Lens Hood after removing the accessory.

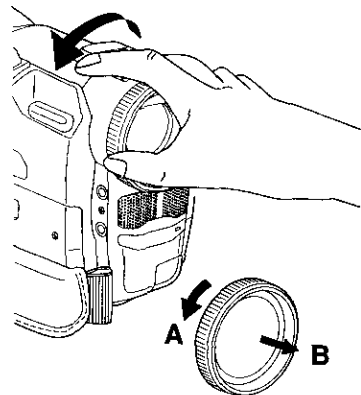

Cleaning EVF (Electronic Viewfinder)

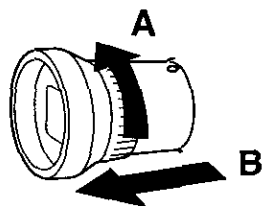
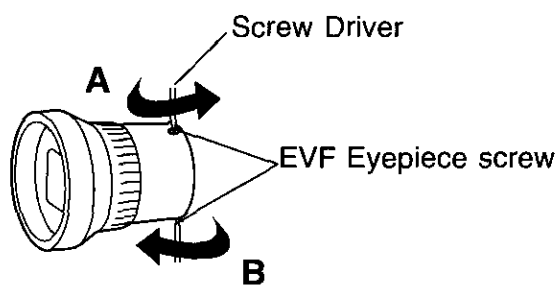

- 1 Remove the EVF Eyepiece 2 screws with a screwdriver (+).
- 2 Turn the Eyepiece counterclockwise 1/8 of a turn.
- 3 Pull the Eyepiece free. Remove any lint or dust particles with a soft clean cloth being careful not to scratch the glass surfaces.
- 4 **To re-install the Eyepiece**
Line up the marks on the Eyepiece with the grooves inside the EVF shaft and attach. Turn it clockwise 1/8 of a turn to lock in place.
- 5 Replace the EVF Eyepiece screws and tighten with a screwdriver.
 - If you lose EVF Eyepiece screw, order Part No.XQN2+BJ4FXK for replacement.

Note:

- The EVF is a fixed type and cannot be extended or retracted. DO NOT apply force.
- Adjust the focus with the Vision Adjustment Control before use.

Notes On Operations

Rough Values of Brightness

Your Palmcorder has been designed for normal scene illumination of 150 footcandles (1500 lx). However, the Palmcorder may be used at F1:1.6, if illumination is more than 0.5 footcandles (5 lx).

The table below shows the color temperature for reference.

PALMCORDER SETTINGS	NATURAL LIGHT CONDITIONS	KELVIN COLOR TEMPERATURE	ARTIFICIAL LIGHT SOURCE	COLOR TINT MIXTURE
	<ul style="list-style-type: none"> Fair weather, blue sky 	10,000	<ul style="list-style-type: none"> Color television 	Bluish
	<ul style="list-style-type: none"> Slightly cloudy sky 	8,000		
	<ul style="list-style-type: none"> Cloudy or rainy sky 	7,000		
	<ul style="list-style-type: none"> Sunlight in clear weather at midday 	6,500	<ul style="list-style-type: none"> Fluorescent lamp (Daylight) Camera flash bulb 	
	<ul style="list-style-type: none"> Average sunlight in clear weather 	6,000		
	<ul style="list-style-type: none"> Sunlight 2 hours after sunrise and before sunset 	5,500		
	<ul style="list-style-type: none"> Sunlight 40 min. after sunrise and before sunset 	5,000	<ul style="list-style-type: none"> Blue lamp for photography 	
	<ul style="list-style-type: none"> Sunlight 30 min. after sunrise and before sunset 	4,500	<ul style="list-style-type: none"> Fluorescent lamp (White) Normal flash bulb Fluorescent lamp (Off-white) Tungsten lamp for photography 	Whitish
	<ul style="list-style-type: none"> Sunlight 20 min. after sunrise and before sunset 	4,000		
	<ul style="list-style-type: none"> Sunlight 30 min. after sunrise and before sunset 	3,500		
	3,200	<ul style="list-style-type: none"> Halogen lamp Iodine lamp 		
	2,800	<ul style="list-style-type: none"> Tungsten lamp Acetylene lamp Kerosene lamp Candlelight 	Yellowish	
	2,000			Reddish

Specifications

Power Source:	Digital Video Camera: 7.2V DC (Battery) 7.8V DC (AC Adaptor) AC Adaptor: 110/120/220/240V AC, 50/60 Hz Battery: Lithium-Ion Type DC 7.2V
Power Consumption:	Digital Video Camera: 7.2V DC 7W (Max. 10W) AC Adaptor: 18W 1W (when not in use.)
Video Signal:	EIA Standard (525 lines, 60 fields) NTSC color signal
Video Recording System:	2 rotary heads, helical scanning system
Audio:	12bit (32kHz) 4 tracks 16bit (48kHz) 2 tracks
Pick-Up System and Device:	One integral color filter Charge Coupled Device (CCD)
Lens:	18:1 zoom lens, F1:1.6 with auto iris control Focal length: 3.9mm - 70.2mm Power zoom function Lens filter diameter: 43mm
Viewfinder:	0.5 inch (12.7mm) Electronic Viewfinder
LCD Monitor:	2.5 inch (63.5mm) Liquid Crystal Display
Minimum Illumination Required:	5 lx (F1:1.6) 0.5 footcandles
Operating Temperature:	32°F~104°F (0°C~40°C)
Operating Humidity:	10%~75%
Weight:	Digital Video Camera: 1.5 lbs. 0.68 kg AC Adaptor: 0.53 lbs. 0.24 kg
Dimensions:	Digital Video Camera: 2-15/16 (W) x 4-1/4 (H) x 5-11/16 (D) inch 73.5 (W) x 107.5 (H) x 145 (D) mm AC Adaptor: 4-1/16 (W) x 2 (H) x 3-1/8 (D) inch 103 (W) x 50 (H) x 79 (D) mm

Weight and dimensions shown are approximate.
Designs and specifications are subject to change without notice.

For Your Information

Before Requesting Service

Cleaning Care for Video Heads

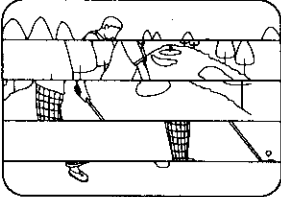

Clogged Video Head

(a) Video Head Cleaning: Normally, your Palmcorder will not require head cleaning. However, it is possible that the heads may become clogged due to dust in the air, damaged tape, long term use, etc. If "NEED HEAD CLEANING" appears for 5 seconds in the EVF or LCD monitor, the heads may require cleaning.

(b) Cleaning the Heads: It is recommended that head cleaning be performed by a qualified service technician. Please contact your nearest Panasonic Service Center. An alternate solution is to obtain a head cleaning cassette. Please use Panasonic cleaning cassette (AY-DVMCL). Be sure to follow the cleaning instructions carefully. Excessive use of the cleaning cassette could shorten head life.

Use this cassette only when a head clogging symptom occurs.

Refer servicing to qualified service personnel.

Caution for Tape Operations

- When you go from function to function (PLAY, FF, REW etc.), please note that the unit will not accept a new function operation until the previous operation is complete.
- The POWER Button, and all function buttons, (PLAY, FF, REW, etc.) are only operational after the tape has been completely loaded.

Lens Hood Area Operation Caution

- With a Wide or Telephoto Conversion Lens (optional) attached, the four corners of the screen may darken when zoom is set to maximum wide angle.
- Attaching the lens hood, a Wide or Telephoto conversion lens (optional), etc. after a filter (optional) has been attached, the four corners of the screen may darken when zoom is set to maximum wide angle.
- With two filters (optional) attached, the four corners of the screen may darken when zoom is set to maximum wide angle.

Self Diagnostic System

If any of the following numbers appear on-screen, the camcorder may have a problem. Do not remove the battery (if attached) and write down the displayed number on page 60. Then, take the camcorder to a service center for repair.

- F01 • F02 • F03 • F04 • F05 • F31 • F51 • F52 • U10 • U11

Before Requesting Service

If you have a problem with your Palmcorder, it may be something you can correct yourself. Check the list below for symptoms and corrections.

Symptom	Correction
No picture in the EVF or LCD Monitor ...	<ul style="list-style-type: none"> • Make sure the Power Source is connected. (pp. 11, 12) • Make sure the POWER switch is set to ON. (pp. 27, 32) • Check the Dew Indicator. (p. 23) • Make sure the battery is fully charged. (p. 10) • Make sure all necessary cables are connected correctly and firmly. (p. 12) • Make sure the Lens Cap is removed. (p. 27)
Video cassette can't be inserted ...	<ul style="list-style-type: none"> • Make sure the Power Source is connected. (pp. 11, 12) • Insert the cassette with the window side facing up. (p. 13)
Video cassette can't be removed ...	<ul style="list-style-type: none"> • Make sure the Power Source is connected. (pp. 11, 12)
No operation starts when operation buttons are pressed ...	<ul style="list-style-type: none"> • Check the Dew Indicator. (p. 23)
Recording cannot be done ...	<ul style="list-style-type: none"> • Make sure the record tab is closed. (p. 14) • Check the Battery Indicator. (p. 20) • Check the Dew Indicator. (p. 23)
Auto Focus does not operate ...	<ul style="list-style-type: none"> • Make sure the FOCUS is set to AUTO. (p. 44) • Make sure the unit is ON with CAMERA mode. (p. 27)
Sound from microphone can't be monitored ...	<ul style="list-style-type: none"> • Make sure the unit is set to REC or Record/Pause mode.
Sound can't be heard ...	<ul style="list-style-type: none"> • Make sure the Audio on the VCR MENU is set to ST1. (pp. 19, 48)

For Your Information

Request for Service Notice

Please photocopy this form when making a request for service notice.

Request for Service Notice:

In the unlikely event this product needs service.

- Please include your **proof of purchase**.
(Failure to do so will delay your repair.)
- To further speed your repair please provide an explanation of what is wrong with the unit and any symptom it is exhibiting.

Mail this completed form and your Proof of Purchase along with your unit to:
Panasonic Services Company
1705 N. Randall Road
Elgin, IL. 60123-7847
Attn: Camcorder Repair

Please write the displayed Self Diagnostic number here.
(see page 58)

Index of Controls

Front View

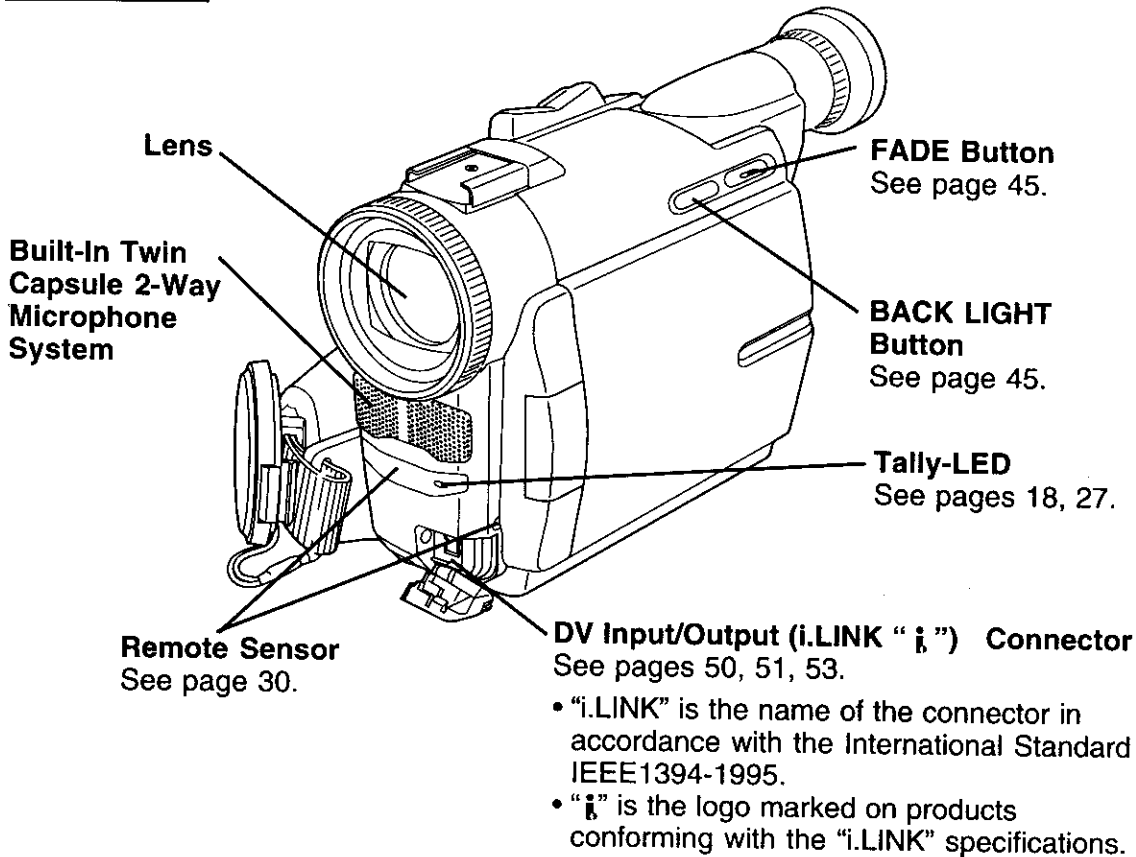

Front View

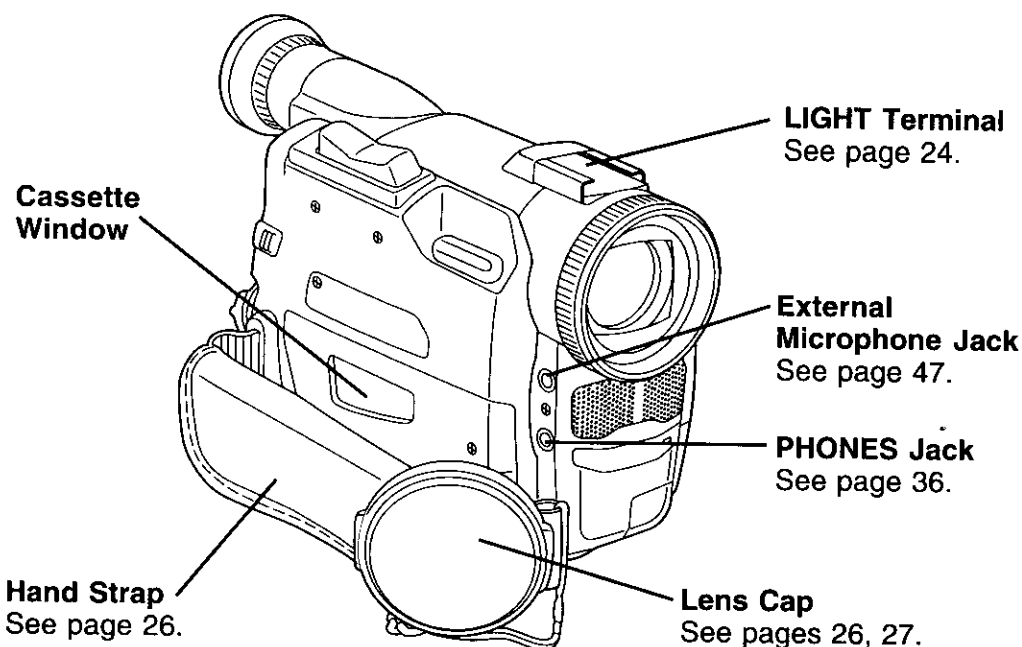

For Your Information

Index of Controls

Rear View

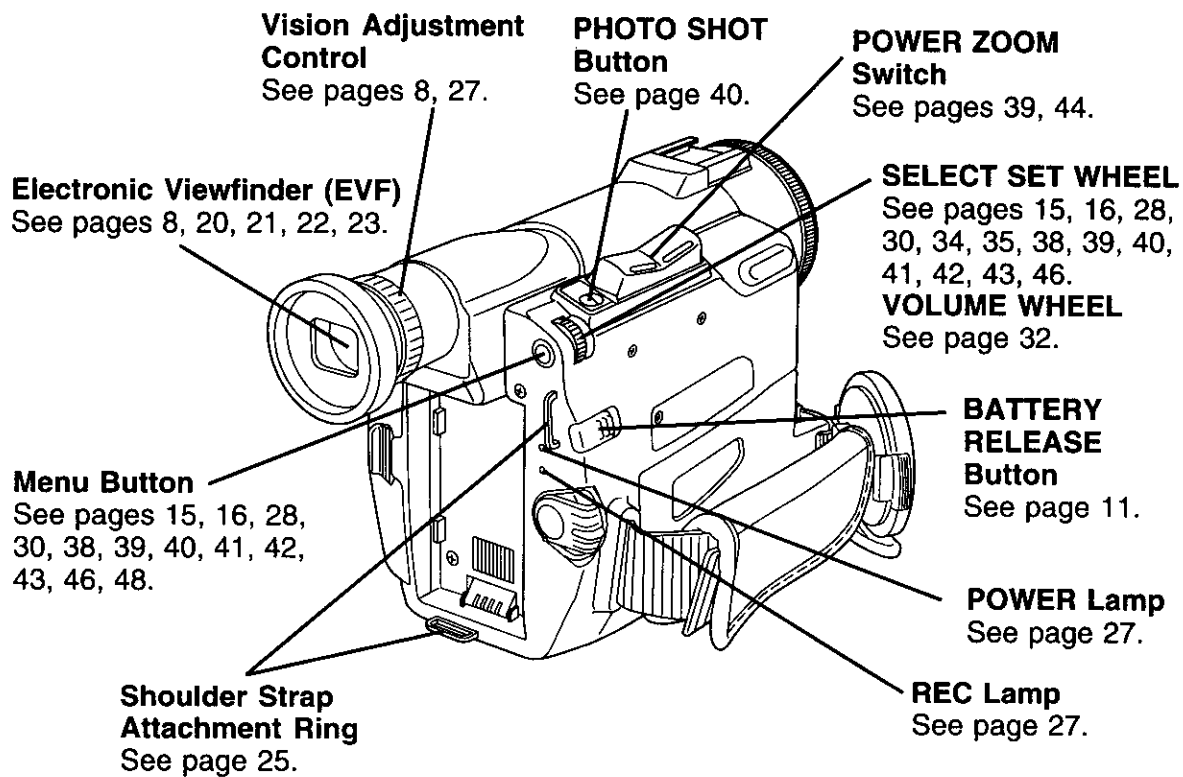

Index of Controls

Rear View

LCD (Liquid Crystal Display) Monitor
See pages 7, 9, 20, 21, 22, 23, 28, 32.

Built-In Speaker
See page 32.

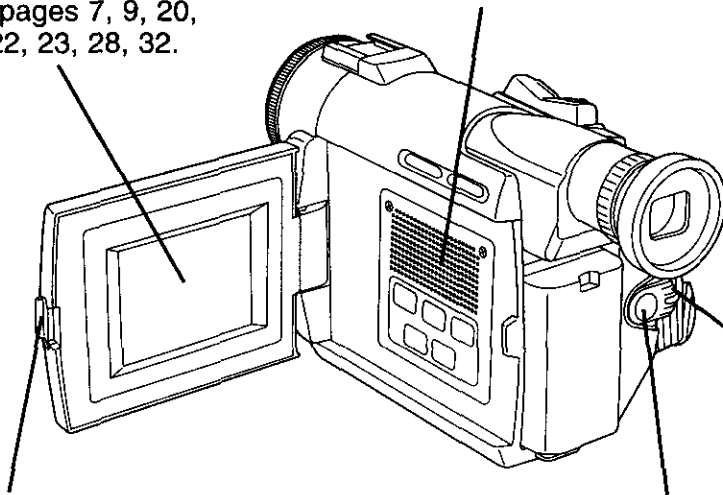

POWER Switch
See pages 7, 8, 9, 27, 29, 30, 37, 47, 49, 50.

LCD-OPEN Button
See pages 7, 9, 28, 32.

RECORD/PAUSE Button
See pages 9, 27, 29.

For Your Information

Index of Controls

Side View

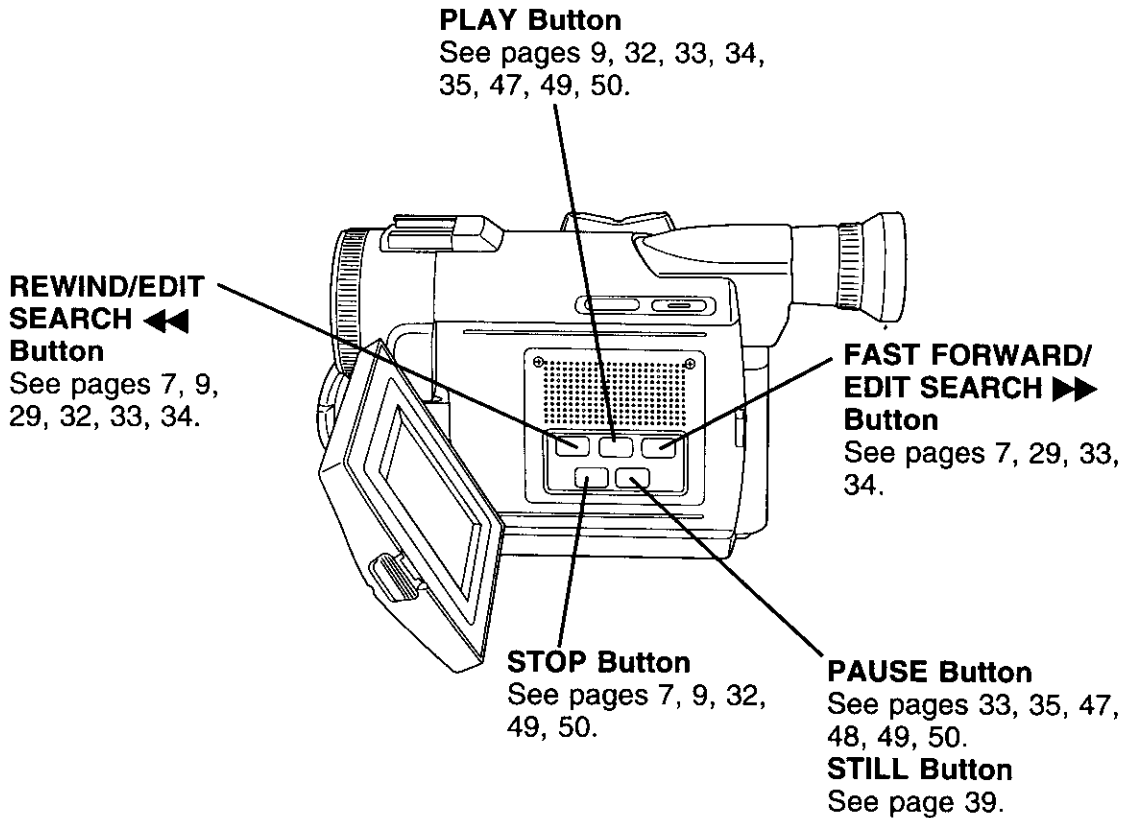

Underside View

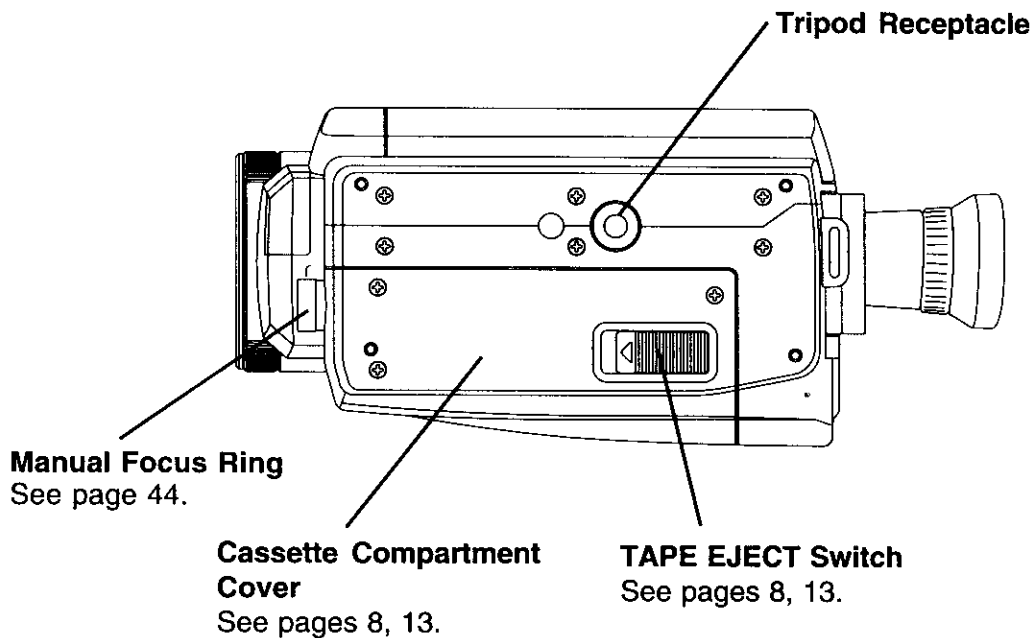

Index of Controls

Jack Box

S-VIDEO Output Connector

See pages 37, 49, 52.

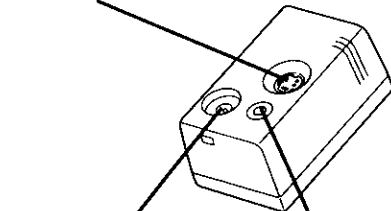

DC Input Connector
See page 12.

Audio/Video Output Connector

See pages 37, 49, 52.

(This connector for use with supplied Audio/Video cable only.)

AC Adaptor

Battery Charging Compartment

See page 10.

POWER Lamp

See page 10.

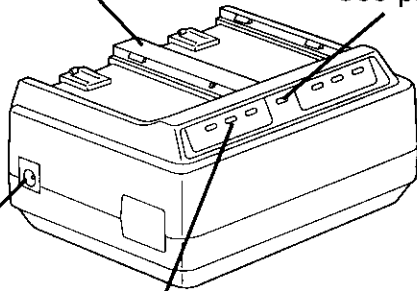

AC Power Cord
See page 10.

VCR DC Output Connector
See page 12.

CHARGE Lamps
See page 10.

CAUTION:

This unit will operate on 110/120/220/240V AC. An AC plug adaptor may be required for voltages other than 120V AC. Please contact either a local or foreign electrical parts distributor for assistance in selecting an alternate AC plug. We recommend using the accessory power plug adaptor (VJSS0070) in an area which has special AC outlets.

For Your Information

Index of Controls

Remote Control (Optional)

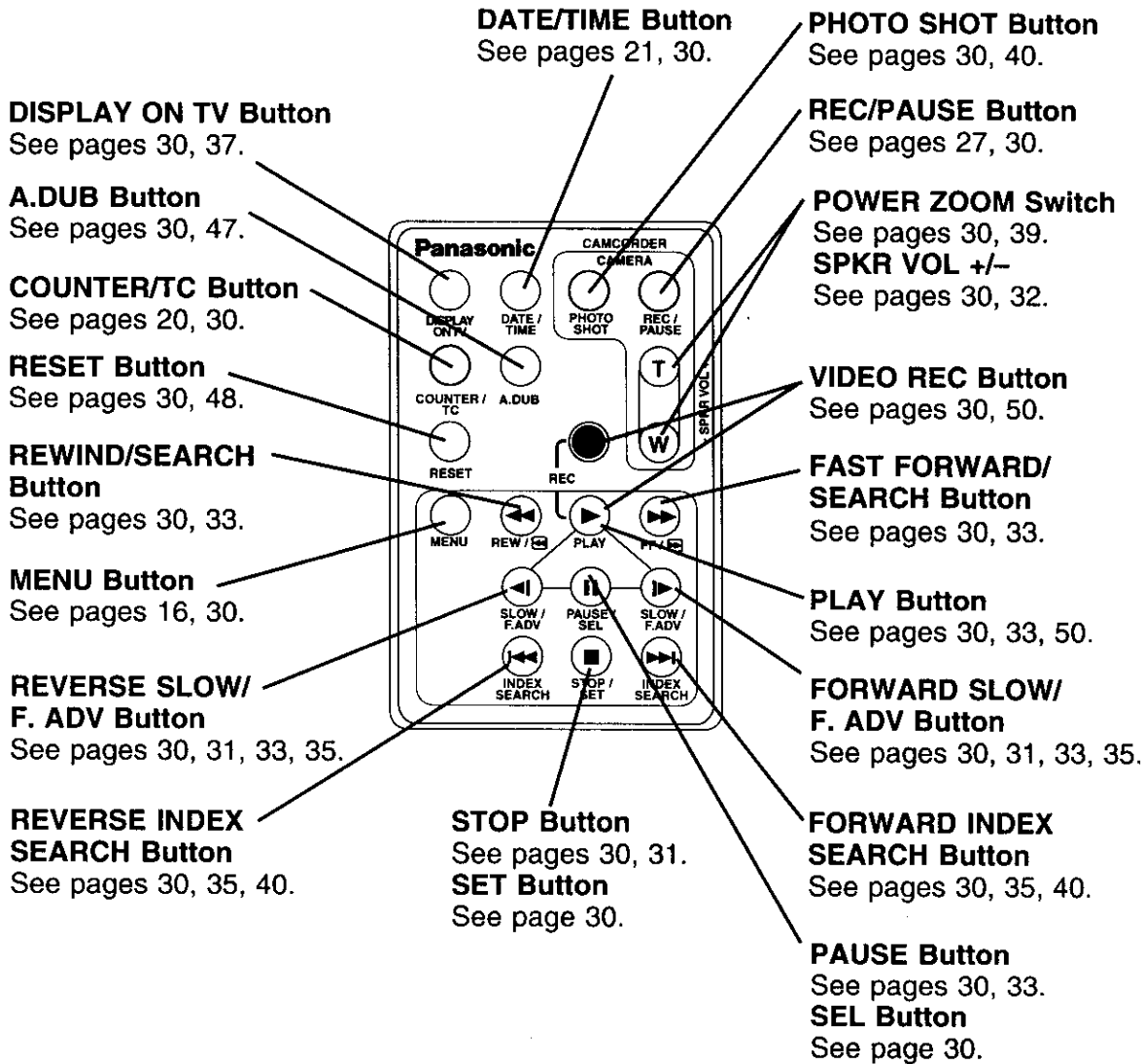

Warranty

Panasonic Consumer Electronics Company, Division of Matsushita Electric Corporation of America
 One Panasonic Way Secaucus,
 New Jersey 07094

Panasonic Sales Company, Division of Matsushita Electric of Puerto Rico, Inc.
 Ave. 65 de Infantería. Km. 9.5
 San Gabriel Industrial Park, Carolina, Puerto Rico 00985

PANASONIC/QUASAR Video Products Limited Warranty

Panasonic Consumer Electronics Company or Panasonic Sales Company (collectively referred to as "the Warrantor") will repair this product with new or refurbished parts, free of charge, in the USA or Puerto Rico, in the event of a defect in materials or workmanship as follows (all time periods commence from the date of the original purchase):

PRODUCT	PARTS	LABOR
CAMCORDER	ONE (1) YEAR, EXCEPT CCD IMAGE SENSOR	NINETY (90) DAYS
	CCD IMAGE SENSOR - SIX (6) MONTHS	NINETY (90) DAYS
VCR	ONE (1) YEAR	NINETY (90) DAYS
AV MIXER	ONE (1) YEAR	NINETY (90) DAYS
MONITOR-VCR	ONE (1) YEAR, EXCEPT CRT	NINETY (90) DAYS
	CRT - TWO (2) YEARS	CRT- NINETY (90) DAYS CUSTOMER PAYS ALL LABOR CHARGES AFTER 90 DAYS

Monitor-VCR In-home or carry-in Service: 22" (diagonal) CRT / LCD and Larger
Monitor-VCR Carry-in Service: 21" (diagonal) CRT / LCD and smaller

Batteries (if included) - New rechargeable batteries in exchange for defective rechargeable batteries for ten (10) days. Non-rechargeable batteries are not warranted.

Tape (if included) - New video cassette tape in exchange for a defective video cassette tape for five (5) days.

In-home, carry-in or mail-in service, as applicable, in the USA can be obtained during the warranty period by contacting a Panasonic Services Company (PASC) Factory Service Center listed in the Service Directory. Or call toll free 1-800-211-PANA(7262), to locate an authorized PASC Service Center. Carry-in or mail-in service in Puerto Rico can be obtained during the warranty period by calling the Panasonic Sales Company telephone number listed in the Service Center Directory.

This warranty is extended only to the original purchaser. A purchase receipt or other proof of the date of the original purchase is required before warranty service is rendered.

This warranty only covers failures due to defects in materials and workmanship which occur during normal use and does not cover normal maintenance, including, but not limited to, video and audio head cleaning. The warranty does not cover damage which occurs in shipment, or failures which are caused by products not supplied by the warrantor, or failures which result from accident, misuse, abuse, neglect, mishandling, misapplication, alteration, modification, faulty installation, set-up adjustments, improper antenna, inadequate signal pickup, maladjustment of consumer controls, improper operation, power line surge, improper voltage supply, lightning damage, commercial use such as hotel, office, restaurant, or other business or rental use of the product, or service by anyone other than a PASC Factory Service Center or a PASC authorized Service Center, or damage that is attributable to acts of God.

LIMITS AND EXCLUSIONS

There are no express warranties except as listed above. THE WARRANTOR SHALL NOT BE LIABLE FOR INCIDENTAL OR CONSEQUENTIAL DAMAGES (INCLUDING, WITHOUT LIMITATION, DAMAGE TO TAPES) RESULTING FROM THE USE OF THIS PRODUCTS, OR ARISING OUT OF ANY BREACH OF THE WARRANTY. ALL EXPRESS AND IMPLIED WARRANTIES, INCLUDING THE WARRANTIES OF MERCHANTABILITY AND FITNESS FOR PARTICULAR PURPOSE, ARE LIMITED TO THE APPLICABLE WARRANTY PERIOD SET FORTH ABOVE. Some states do not allow the exclusion or limitation of incidental or consequential damages, or limitations on how long an implied warranty lasts, so the above exclusions or limitations may not apply to you.

This warranty gives you specific legal rights and you may also have other rights which vary from state to state.

If a problem with this product develops during or after the warranty period, you may contact your dealer or Service Center. If the problem is not handled to your satisfaction, then write to the Customer Satisfaction Center at the Panasonic Consumer Electronics Company address above.

SERVICE CALLS WHICH DO NOT INVOLVE DEFECTIVE MATERIALS OR WORKMANSHIP AS DETERMINED BY THE WARRANTOR, IN ITS SOLE DISCRETION, ARE NOT COVERED. COSTS OF SUCH SERVICE CALLS ARE THE RESPONSIBILITY OF THE PURCHASER.

warvid 10/20/97

For Your Information

Warranty

For Product Information, operating Assistance, Literature Request, Dealer Locations, and all Customer Service inquiries please contact:

1-800-211-PANA(7262), Monday-Friday 9am-9pm Saturday-Sunday 9am-7am, EST.

Web Site: <http://www.panasonic.com>

You can purchase parts, accessories or locate your nearest service center by visiting our Web Site.

Accessory Purchases:

1-800-332-5368 (Customer Orders Only)

Panasonic Service Company 20421 84th Avenue South, Kent, WA 98032

(6 am to 5 pm Monday - Friday; 6 am to 10:30 am Saturday; PST)

(Visa, Master Card, Discover Card, American Express, Check)

Product Repairs

Centralized Factory Service Center

MAIL TO : Panasonic Services Company
1705 N. Randall Road,
Elgin, IL 60123-7847
Attention: Digital Camera Repair

Please carefully pack and ship, prepaid and insured, to the Elgin centralized repair Factory Service Center. While there will be added handling delays, you may bring your unit to one of the following locations who will then forward the unit to Elgin for repair.

Customer's in Puerto Rico, please ship or carry in to location below ("Service in Puerto Rico").

Factory Service Center Locations

CALIFORNIA

550 Katella Avenue
Cypress, CA 90630
800 Dubuque Avenue
S. San Francisco,
CA 94080
20201 Sherman Way
Suite 102
Canoga Park, CA 91306
3878 Ruffin Road
Suite A
San Diego, CA 92123

COLORADO

1640 South Abilene
Street Suite D
Aurora, CO 80012

FLORIDA

3700 North 29th Avenue
Suite 102
Hollywood, FL 33020

GEORGIA

8655 Roswell Road
Suite 100
Atlanta, GA 30350

ILLINOIS

9060 Golf Road
Niles, IL 60714
1703 North Randall Road
Elgin, IL 60123
(Pick-up / Drop-off only)

MARYLAND

62 Mountain Road
Glen Burnie MD 21061

MASSACHUSETTS

60 Glacier Drive,
Suite G
Westwood, MA 02090

MICHIGAN

37048 Van Dyke Avenue
Sterling Heights, MI
48312

MINNESOTA

7850-12th Avenue South
Airport Business Center
Bloomington, MN 55425

OHIO

2236 Waycross Road
Civic Center Plaza
Forest Park, OH 45240

PENNSYLVANIA

2221 Cabot Blvd. West
Suite B
Langhorne, PA 19047
Chartiers Valley
Shopping Center
1025 Washington Pike
Bridgeville, PA 15017

TENNESSEE

3800 Ezel Road
Suite 806
Nashville, TN 37211

TEXAS

7482 Harwin Drive
Houston, TX 77036
13615 Welch Road
Suite 101
Farmers Branch,
TX 75244

WASHINGTON

20425-84th Avenue
South
Kent, WA 98032

HAWAII

99-859 Iwaiwa Street
Aiea, Hawaii 96701
Phone (808) 488-1996
Fax (808) 486-4369

Service in Puerto Rico

Matsushita Electric of Puerto Rico, Inc. Panasonic Sales Company/ Factory ServiceCenter:
Ave. 65 de Infantería. Km. 9.5 San Gabriel Industrial Park Carolina, Puerto Rico 00985

Phone (787) 750-4300 Fax (787) 768-2910

As of April '98

Index

A		Digital Zoom	39	R	
AC Adaptor	2, 10, 12, 53, 65	Dubbing over		REC Indicator	20, 21
Accessories (Optional)	53	Audio(Microphone)	47, 48	Recording Still Pictures	39
Accessories (Supplied)	2	DV Interface Cable	50, 51, 53	Remote Control	2, 30, 31, 66
Audio/Video Cable	2, 37, 49	E		Request for Service Notice	59
Audio/Video Fade In/Out	45	Edit Search	29	S	
Auto Focus	44	Erase Protection Tab	14	Safety Precautions	3
AV Jack Box	2, 12, 36, 53, 65	EVF/LCD Monitor		Self Demo Mode	7
B		Indications	20, 21, 22, 23	Set the Date and Time	15
Backlight	45	F		Shoulder Strap	2, 25
Battery Charging		Fade In/Out	45	Special Effects Playback	33, 34, 35
Confirmation Marker	10	H		Specifications	56
Battery Pack	2, 8, 10, 11, 53	Hand Strap	26	Still Picture	33
Battery Remaining		High Speed Shutter	46	Symptom/Correction	58
Indication	20	J		T	
Battery Warning	23	Jog Search	35	Tab	14
Book Mark Search	30	L		Tape Remaining Indications	20
C		Lens Cap	2, 26, 27, 61	Tape Speed	14
Camera Recording		M		Tape Warning	22
27, 28, 29, 30		Macro Focus	44	V	
Cleaning Care for Video		Manual Focus	44	VHF Connecting Cable	49
Heads	57	Memory Counter	20	Video Cassettes (tapes)	14
Clock Battery	2, 23	MENU OSD	17, 18, 19	Volume Display	21
Clock Set	15	P		W	
Color Enhancement Light		PC Connection	51	Warranty	67, 68
2, 24, 26, 65		PLAY Indicator	20, 21	White Balance	41
Copying from Digital		Playback		Z	
Equipment	50	32, 33, 34, 35, 36, 37		Zoom In/Out	39
Copying your Tapes	49	Power Supply	10, 11, 12		
D		Program AE	42		
Date and Time Indication	21				
DC Power Cable	2, 12, 53				
DEW Indication	23				
Digital E.I.S.	38				
Digital Functions	43				
Digital Photo Shot	40				
Digital Video Cassette Tape					
2, 14					

For Your Information

**Panasonic Consumer Electronics
Company, Division of Matsushita
Electric Corporation of America**

One Panasonic Way Secaucus,
New Jersey 07094

Printed in Japan
LSQT0148 1999

**Panasonic Sales Company,
Division of Matsushita Electric of
Puerto Rico, Inc. ("PSC")**

Ave. 65 de Infantería, Km. 9.5
San Gabriel Industrial Park
Carolina, Puerto Rico 00985

