

Panasonic Omnivision **VHS**

Combination VCR Operating Instructions

Models ^{LIBRA} **PV-M2079/PV-M2089**



Basic Operation

Advanced Operation

For Your Information



As an ENERGY STAR® Partner, Matsushita Electric Corporation of America has determined that this product or product model meets the ENERGY STAR® guidelines for energy efficiency.



Please read these instructions carefully before attempting to connect, operate or adjust this product. Please save this manual.

Spanish Quick Use Guide is included. (Guía para rápida consulta en español está incluida.)

For assistance, call 1-800-211-PANA(7262)

Important Safeguards and Precautions

READ AND RETAIN ALL SAFETY AND OPERATING INSTRUCTIONS. HEED ALL WARNINGS IN MANUAL AND ON UNIT

INSTALLATION

1 POWER SOURCE CAUTION

Operate only from power source indicated on unit or in this manual. If uncertain, have an Electric Utility Service Company or Video Products Dealer verify your home power source.

2 POWER CORD PLUG

For safety, this unit comes with a polarized type plug (one wide blade), or a three-wire grounding type plug.

POLARIZED PLUG CAUTION:

The plug fits into outlet one way. If it cannot be fully inserted, try reversing it. If it still will not fit, have an electrician install the proper wall outlet. Do not tamper with the plug.

GROUNDING PLUG CAUTION:

The plug requires a three-hole grounding outlet. If necessary, have an electrician install the proper outlet. Do not tamper with the plug.

3 POWER CORD

Make sure power cords are routed so they are not likely to have anything rest on them, roll over them, or be in the way of walking traffic. An extension cord should have the same type plug (polarized or grounding) and must be securely connected. Overloading wall outlets or extension cords may cause fire hazard. Frayed cords, damaged plugs, and damaged or cracked wire insulation are hazardous and should be replaced by a qualified electrician.

4 DO NOT BLOCK VENTILATION HOLES

Ventilation openings in the cabinet release heat generated during operation. If blocked, heat build-up may result in a fire hazard or heat damage to cassettes.

For your protection:

- Never cover ventilation slots while unit is ON, or operate unit while placed on a bed, sofa, rug, or other soft surface.
- Avoid built-in installation, such as a book case or rack, unless properly ventilated.

5 AVOID EXTREMELY HOT LOCATIONS OR SUDDEN TEMPERATURE CHANGES

Do not place unit over or near a heater or regulator, in direct sunlight, etc. If unit is suddenly moved from a cold place to a warm place, moisture may condense in unit and on the tape causing damage.

6 TO AVOID PERSONAL INJURY

- Never place unit on support or stand that is not firm, level, and adequately strong. The unit could fall causing serious injury to a child or adult and damage to the unit.
- Move any appliance and cart combination with care. Quick stops, excessive force, and uneven surfaces may cause objects to overturn.
- Carefully follow all operating instructions.



OUTDOOR ANTENNA INSTALLATION

1 SAFE ANTENNA AND CABLE CONNECTION

An outside antenna or cable system must be properly grounded to provide some protection against built up static charges and voltage.

Section 810 of the National Electrical Code, ANSI/NFPA 70 (in Canada, part 1 of the Canadian Electrical Code) provides information regarding proper grounding of the mast and supporting structure, grounding of the lead-in wire to an antenna discharge unit, size of grounding conductors, location of antenna discharge unit, connection to grounding electrodes, and requirements for the grounding electrode.

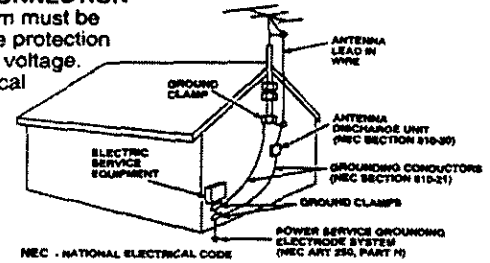

2 KEEP ANTENNA CLEAR OF HIGH VOLTAGE POWER LINES OR CIRCUITS

Locate an outside antenna system well away from power lines and electric light or power circuits so it will never touch these power sources should it ever fall. When installing antenna, absolutely never touch power lines, circuits or other power sources as this could be fatal.

USING THE VIDEO UNIT

Before unit is brought out of storage or moved to a new location, refer again to the INSTALLATION section of these safeguards.

1 KEEP UNIT WELL AWAY FROM WATER OR MOISTURE, such as a kitchen sink, bath tub, pool, and so on.

2 IF EXPOSED TO RAIN, MOISTURE, OR STRONG IMPACT, unplug unit and have it inspected by a qualified service technician before use.

3 ELECTRICAL STORMS

During a lightning storm, or before leaving unit unused for extended periods of time, disconnect all equipment from the power source as well as the antenna and cable system.

4 WHEN UNIT IS PLUGGED IN

- Never expose to rain or water. DO NOT OPERATE if liquid has been spilled into unit. Immediately unplug unit, and have it inspected by a service technician. Fire and shock hazards can result from electrical shorts caused by liquid contact inside.
- Never drop or push any object through openings in unit. Some internal parts carry hazardous voltages and contact can cause electric shock or fire hazard.
- Avoid placing unit directly on top or underneath a TV as this may cause electrical interference. Keep all magnets away from electronic equipment.

5 USING ACCESSORIES

Use only accessories recommended by the manufacturer to avoid risk of fire, shock, or other hazards.

6 CLEANING UNIT

Unplug unit. Use a clean, dry, chemically untreated cloth to gently remove dust or debris. DO NOT USE cleaning fluids, aerosols, or forced air that could over-spray, or seep into unit and cause electrical shock. Any substance, such as wax, adhesive tape, etc. may mar the cabinet surface. Exposure to greasy, humid, or dusty areas may adversely affect internal parts.

SERVICE

1 DO NOT SERVICE PRODUCT YOURSELF

If, after carefully following detailed operating instructions, the unit does not operate properly, do not attempt to open or remove covers, or make any adjustments not described in the manual. Unplug unit and contact a qualified service technician.

2 REPLACEMENT OF PARTS

Make sure the service technician uses only parts specified by the manufacturer, or have equal safety characteristics as original parts. The use of unauthorized substitutes may result in fire, electric shock, or other hazards.

3 SAFETY CHECK AFTER SERVICING

After unit is serviced or repaired, request that a thorough safety check be done as described in the manufacturer's service literature to insure video unit is in safe operating condition.

Safety Precautions

Warning: To prevent fire or shock hazard, do not expose this equipment to rain or moisture.

This video recorder, equipped with the HQ (High Quality) System, is compatible with existing VHS equipment.

Only use those tapes with the **HQS** mark. It is recommended that only cassette tapes that have been tested and inspected for use in 2, 4, 6, and 8 hour VCR machines be used.

This television receiver provides display of television closed captioning in accordance with §15.119 of the FCC rules.

FCC WARNING: Any unauthorized changes or modifications to this equipment would void the user's authority to operate.

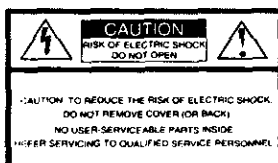

This symbol warns the user that uninsulated voltage within the unit may have sufficient magnitude to cause electric shock. Therefore, it is dangerous to make any kind of contact with any inside part of this unit.

This symbol alerts the user that important literature concerning the operation and maintenance of this unit has been included.

Therefore, it should be read carefully in order to avoid any problems.

Table of Contents

Use Now!

Important Safeguards and Precautions	2
Before Using	4
• Accessories.....	4
• Record/Playback Time	4
• Loading the Batteries	4
• Prevent Accidental Tape Erasure ..	4
Connections (Outdoor Antenna Connections, DSS/Cable Box Connections)	5
One Time Setup (Language, Channel, Clock)	6, 7
TV Operation (NITE mode, Using the 100 key, Rapid Tune, Audio Mute, Phones, SELF-DEMO mode)....	8
MTS Broadcast/TV Stereo System	9
• Stereo/SAP/Mono Operation	9
• Select Audio mode for TV Viewing	9
Playback a Tape (Slow Motion, Still Picture, Frame by Frame, Features for Quality) ..	10
Record On a Tape	11
• One Touch Recording	11
• Selecting Input Mode	11

Enjoy More!

Timer Recording	12, 13
• Timer Recording Using	12
• Review, Replace or Clear	13
• Combination VCR Buttons	12
• Program Contents.....	13
Timer Programming using VCR Plus+ System	14 ~ 17
• VCR Plus+ System Setup ..	15,16
• VCR Plus+ System Programming ..	17
TV Timer Features (ON-TIMER with Alarm, SLEEP TIMER, INSTANT ALARM) ..	18, 19
Closed Caption System	20, 21
• Closed Caption Mode Feature ..	20
• Caption on Mute Feature	21
FM Radio	22, 23
Tape Operation	24 ~ 27
• Tape Position Display.....	24
• Zero Search	24
• Repeat Play	25
• Auto Operation Functions.....	25
• One Minute Skip	25
• VHS Index Search System ..	26, 27
Special VCR Features	28 ~ 32
• Channel Caption.....	28, 29
• Time Stamp	30, 31
• Weak Signal Display ON/OFF ..	32
• VCR Lock	32
Copying Your Tapes (Dubbing)	33
V-Chip Control Feature	34 ~ 37
• Enter or Change Secret Code ..	34
• Setup TV PARENTAL Ratings ..	36
• Setup MOTION PICT. Ratings ..	35
• Blocking Message.....	37
Cable Box Universal Remote Control	38, 39
• Remote Warning ON/OFF	39
• DSS and Cable Box Code List ..	39
Picture Adjustment	40
Audio Features <For Model PV-M2089 only>	41

Other Information!

Reset Language, Clock, Channel	42
On-Screen Display (OSD)	43
• VCR Status & Clock Display....	43
• Channel & Function Display	43
• Warning and Instruction	43
• Displays	43
Unit Information	44
• Reset all Combination VCR	44
• Head Cleaning	44
• Memory Functions	44
• Specifications	44
• DST (Daylight Saving Time)	44
Before Requesting Service	45
Service Center List	46
Spanish (Español) Quick Use Guide	47 ~ 49
Location of Controls	50, 51
Warranty	Back Cover

Basic Operation

Advanced Operation

For Your Information

Before Using

Congratulations

on your purchase of one of the most sophisticated and reliable products on the market today. Used properly, it will bring you and your family years of enjoyment. Please fill in the information bellow. The serial number is on the tag located on the back of your Combination VCR.

Date of Purchase _____
 Dealer Purchased From _____
 Dealer Address _____
 Dealer Phone No. _____
 Model No. _____
 Serial No. _____

Accessories

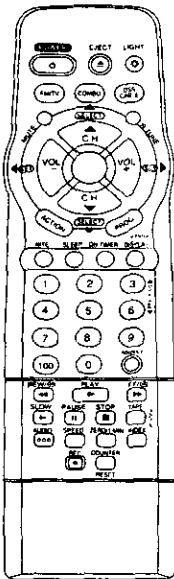

Remote Control
VSQS1603

Batteries
2 "AA"

To order accessories,
call toll free 1-800-332-5368.

Loading the Batteries

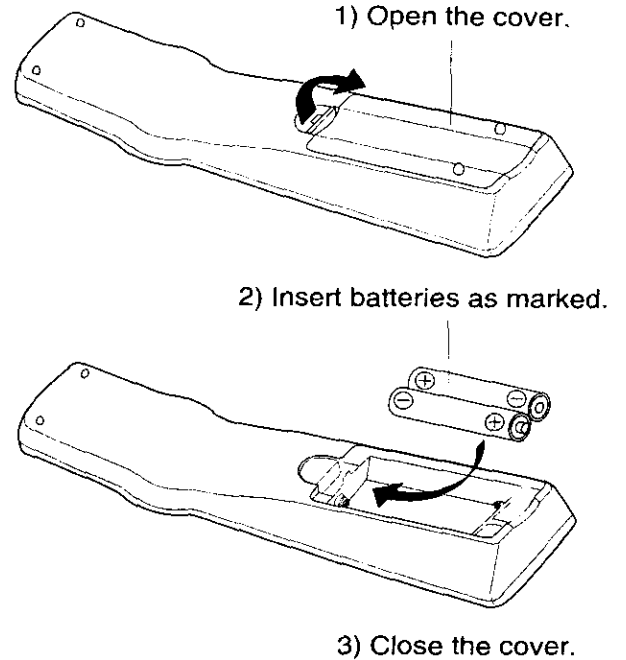

- Battery replacement caution**
- Do not mix old and new batteries.
 - Do not mix alkaline with manganese batteries.

Prevent Accidental Tape Erasure

Break off the tab.

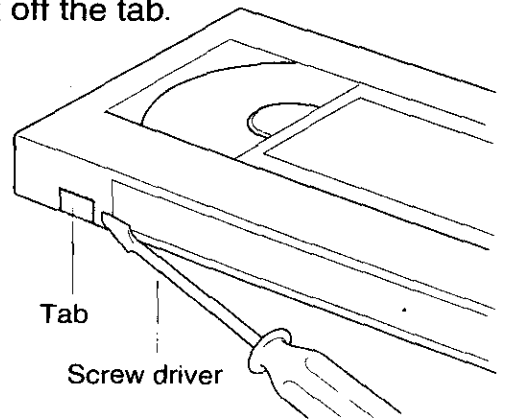

To record again.

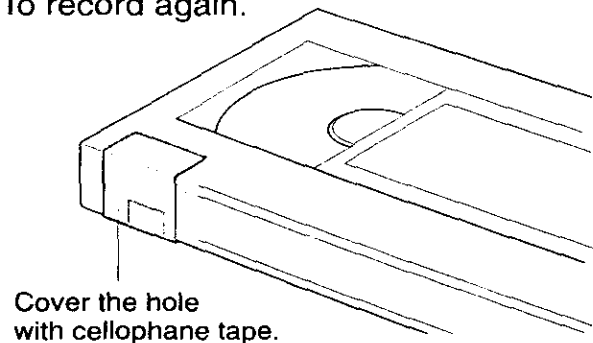

Record/Playback Time

Only use tapes with the **VHS** mark in this unit.

Tape Speed Setting	Type of Video Cassette		
	T60	T120	T160
SP (Standard Play)	1 Hour	2 Hours	2 Hours 40 minutes
LP (Long Play)	2 Hours	4 Hours	5 Hours 20 minutes
SLP (Super Long Play)	3 Hours	6 Hours	8 Hours

Connections

Outdoor Antenna Connections

Unhook the antenna from your previous TV or VCR and connect it to the back of the Combination VCR as shown in the diagram.
If your antenna system has separate UHF and VHF lead-ins, you need a UHF/VHF Band Mixer (not supplied.)

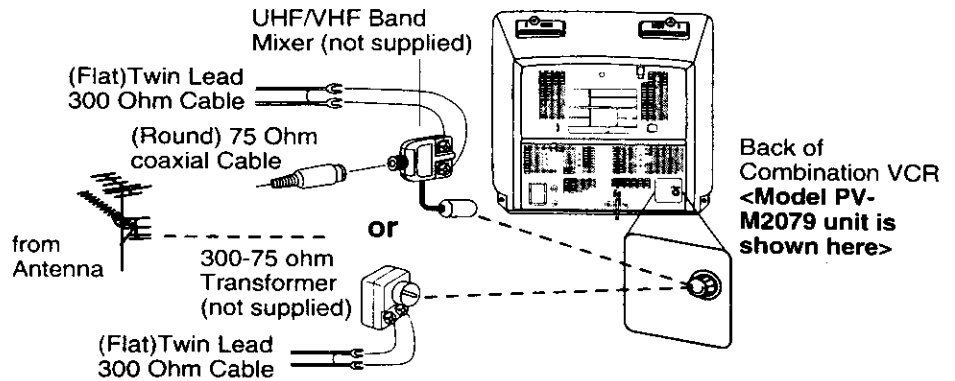

DSS/Cable box Connections

Without a Cable Box

- You can;
- record or view unscrambled channels.
- You cannot;
- record or view scrambled channels.
 - view a channel other than the one selected for any type of recording.

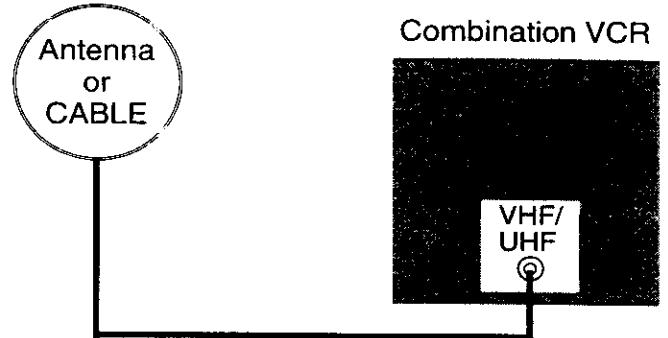

With a Cable Box

- You can;
- record or view any channel including scrambled channels.
- NOTE: Channel selection must be made at the cable box.
- You cannot;
- view a channel other than the one selected for any type of recording.
 - do a Timer recording of a channel unless you select it at the cable box.

Note to CABLE System Installer
This reminder is provided to call the CABLE (Cable TV) System Installers attention to Article 820-40 of the NEC that provides guidelines for proper grounding and, in particular, specifies that the cable ground shall be connected to the grounding system of the building, as close to the point of cable entry as practical.

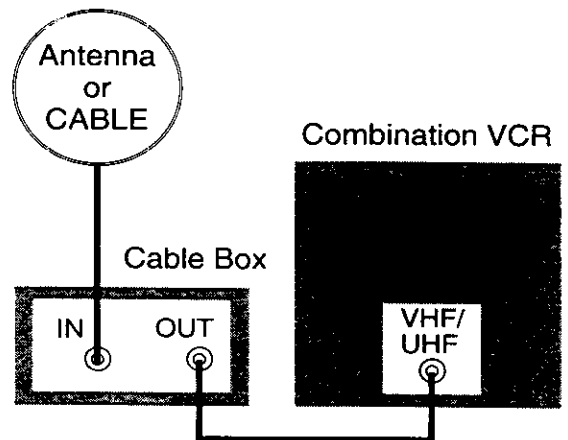

With a DSS Receiver

- You can;
- record or view any channel including scrambled channels.
- NOTE: Channel selection must be made at the DSS Receiver.
- You cannot;
- view a channel other than the one selected for any type of recording.
 - do a Timer recording of a channel unless you select it at the DSS box.

NOTE: The DSS receiver must be turned off to view programs from a cable box or antenna. See the DSS manual for details.

*DSS® is registered trademark of DIRECTV, INC., a unit of GM Hughes Electronics.

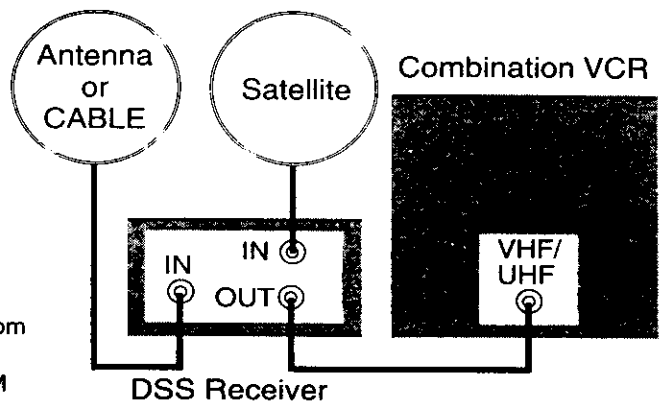

One Time Setup

When the Combination VCR is turned on the first time, setup mode is entered automatically.



Process of Setup

Language → Channel → Clock

1  Press **POWER*** on the Combination VCR.

2 **Select the language.**

SELECT LANGUAGE
 PUSH CH ▲ : English
 OPRIMIR CH ▼ : Español
 APP. VOL + : Français

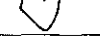
 for English
 for Spanish (Español)
 for French (Français)

- If wrong language is set, do "Reset all Combination VCR Memory Functions" steps page 44.
- If you use a cable box, the cable box must be left on.

3 **Start Channel Auto Set and Clock Auto Set.**

CHANNEL/CLOCK AUTO SET
 CONNECT ANTENNA CABLE AND IF YOU USE A CABLE BOX, TUNE IT TO YOUR LOCAL PBS CH THEN...
 PLEASE PUSH CH UP KEY

 Press **CH ▲**.

CH AUTO SET PROCEEDING

AUTO CLOCK SET PROCEEDING

Case 1
 (Setup completed)

7/28/1999 WED 12:00PM
 DST: ON
 SETTING : CH 10
 AUTO CLOCK SET COMPLETED
 END : PUSH CH UP KEY

 Press **CH ▲** to exit.
 • If your area observes daylight saving time, but you would like to turn the DST feature off, do the Reset Clock steps on page 42 and set DST:OFF.

- If your area observes daylight saving time and DST is set to ON, but the time is incorrect; do the Time Zone Adjust steps on the next page.

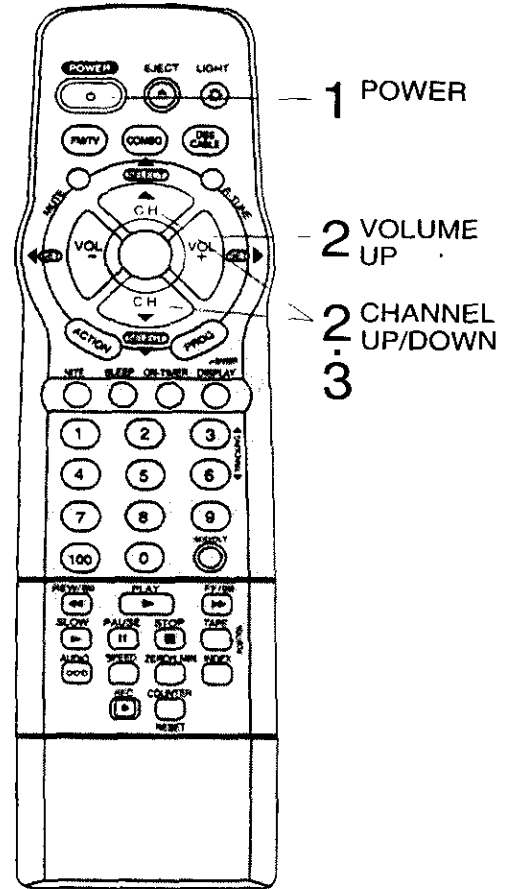

Case 2
 (Setup incomplete)

AUTO CLOCK SET IS INCOMPLETE
 PUSH ACTION TO SET CLOCK

See Case 2 next page.

IMPORTANT NOTE FOR AUTO CLOCK SET

- Auto clock set is performed the first time when Combination VCR is turned off each day. If used, a cable box must be left on and tuned to the PBS channel at the time Combination VCR power is turned off if you want auto clock set to be done.
- If used, a DSS receiver, it must be turned off for auto clock set.
- If Cable Box or DSS receiver is connected to Combination VCR via Audio/Video Jacks, an RF coaxial cable must also be connected for auto clock set and channel auto set features.
- If for any reason the time is changed manually, automatic time correction will not occur.

★ Important: If the remote control POWER, CH Up/Down, NUMBERED keys, ACTION, PROG, DISPLAY, TAPE POSITION, INDEX, ON-TIMER, R-TUNE, FM/TV, and ADD/DLT button does not work when pressed, press COMBO button on the remote and try the button again.

Case 1 Set TIME ZONE ADJUST.

1  **Display MAIN MENU.**
Press ACTION.

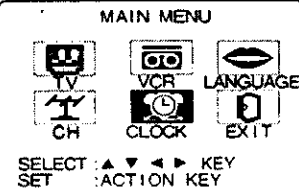
2  **Display SET CLOCK screen.**
1) Press ▲▼◀▶ to select "CLOCK."
2) Press ACTION to display.

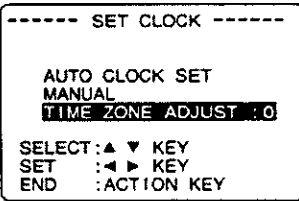
3  **Select TIME ZONE ADJUST.**
1) Press ▲▼ to select.
2) Press ▶◀ to subtract or add hour(s) as necessary.

4  **End setup.**
Press ACTION twice.
• TIME ZONE ADJUST returns to "0" if clock is set manually.

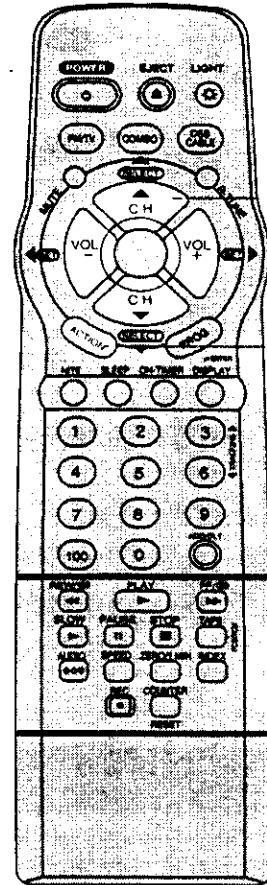

Case 2 Clock Setup is Incomplete. Set the clock manually.

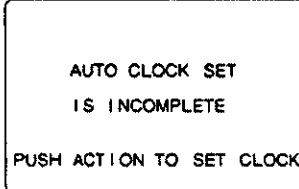
a  **Display SET CLOCK screen.**
Press ACTION to exit this mode.

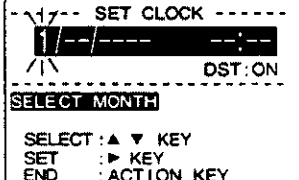
b  **Set the clock manually.**
1) Press ▲▼ to select the month.
2) Press ▶ to set.

• Likewise set date, year, time, and DST (Daylight Saving Time.)

To Make Corrections, repeatedly press ▶◀ to move to error, then correct.

c  **End setup.**
Press ACTION twice (Clock starts.)

Notes

- This Combination VCR calendar is accurately maintained its calendar up to Dec. 31, 2089, 11:59PM.
- Channel auto set selects normal TV or Cable channels depending on your Combination VCR hookup.

Using ▲▼◀▶ keys

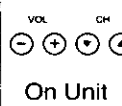
	▲:CH UP ▼:CH DOWN ▶:VOLUME UP ◀:VOLUME DOWN
On Remote	
Whenever the menu or program screen is displayed, CHANNEL UP/DOWN and VOLUME UP/DOWN function as ▲▼◀▶ only.	
	
On Unit	

ACTION key on the unit

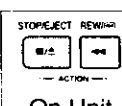
	You can operate the menu screen using unit buttons. To display the menu, press STOP/EJECT and REW together with no tape inserted.
On Unit	
To exit the menu, repeat above with or without tape inserted.	

TV Operation

*** Important:** If the remote control POWER, CH Up/Down, NUMBERED keys, ACTION, PROG, DISPLAY, TAPE POSITION, INDEX, ON-TIMER, R-TUNE, FM/TV, and ADD/HLT button does not work when pressed, press COMBO button on the remote and try the button again.

1

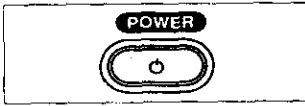

Press **POWER*** on the Combination VCR.



Check list before you begin.

- All connections are made (see page 5.)
- Your Combination VCR is plugged in.

2

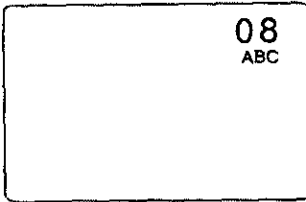

Select a channel.

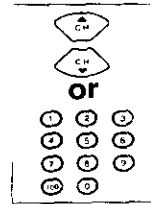

Using CH ▲▼ or NUMBERED keys.

Model PV-M2079 unit is shown here.

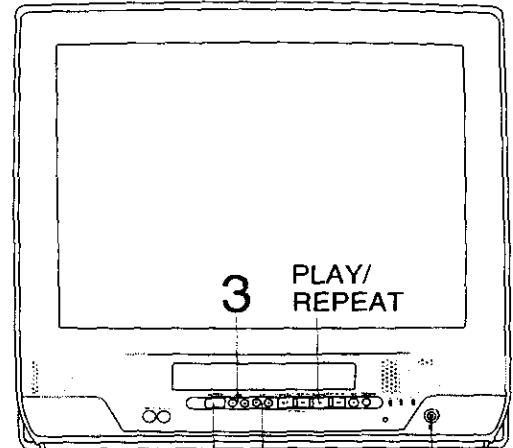

1 2 PHONES Jack

3

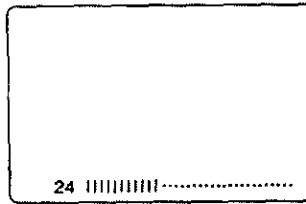

Adjust volume.

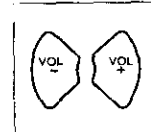

Press VOL+—.

NITE Mode

Color and picture intensity levels are adjusted so the screen is easier on your eyes during night time use.

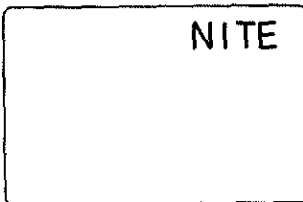

Set NITE mode.

Press NITE.

- NITE mode may be selected when watching TV, playing a tape, or while in FM mode.

To Cancel, press NITE.

- Previous settings are restored.
- NITE mode is cancelled when power is turned off or power failure occurs.

Using the 100 key

When selecting CABLE channels 100 to 125 with the NUMBERED keys, first press the 100 key, and then enter the remaining two digits.

Rapid Tune

Press R-TUNE to display the last channel you were watching.

Audio Mute

Press MUTE to instantly mute the sound.
Press again, to restore the previous sound level.

Phones

Connect an earphone (not supplied) or headphones (not supplied) to the Phones Jack.

SELF-DEMO Mode

With Power ON, hold down PLAY/REPEAT on the Combination VCR for 5 seconds to display demo screen.
Repeat this to exit.

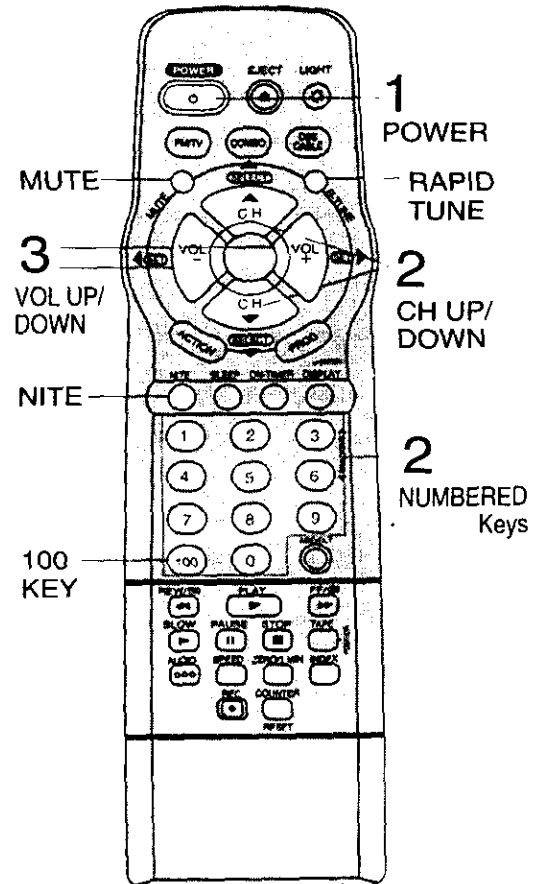

8

For assistance, call 1-800-211-PANA(7262)

MTS Broadcast/TV Stereo System

Receivable Broadcast Types

The following are possible broadcast types with their accompanying on-screen displays. The signal being received is indicated with an "Ⓜ" mark while the selected audio mode is indicated with an arrow. To change the audio mode for these broadcasts, follow the "Select Audio Mode for TV Viewing" section (below.)



Display the broadcast signal being received.

Press DISPLAY to display.

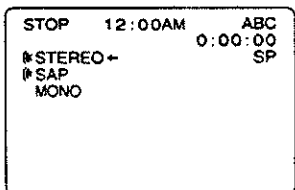

MTS Stereo and SAP broadcast

Multi-channel Television Sound Stereo (main language) and Secondary Audio Program (sub language) broadcasts are both being received simultaneously. Select the STEREO or SAP audio mode.

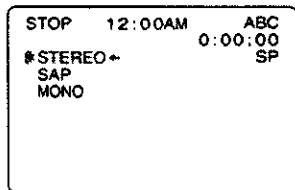

MTS Stereo broadcast

Multi-channel Television Sound Stereo broadcast. Select STEREO audio mode. • If stereo broadcast is weak and the display flickers, select MONO audio mode for possibly better results.

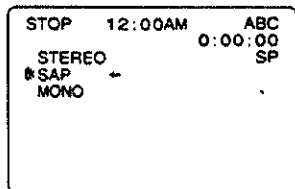

SAP broadcast

Secondary Audio Program (sub language.) Select SAP audio mode for the sub language.

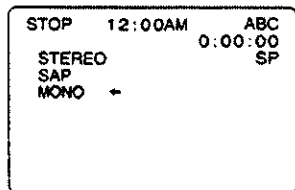

MONO broadcast

Normal monaural sound broadcast.

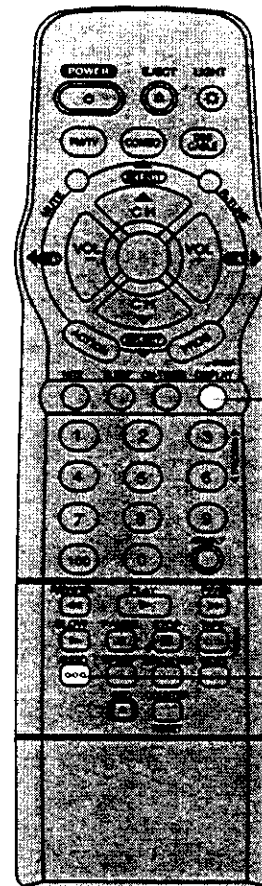

DISPLAY

AUDIO

Select Audio Mode for TV Viewing



Press AUDIO to select the desired audio mode as described above. (Arrow shows selection.)

- Each press of AUDIO will change the audio mode as shown below.

< Example >

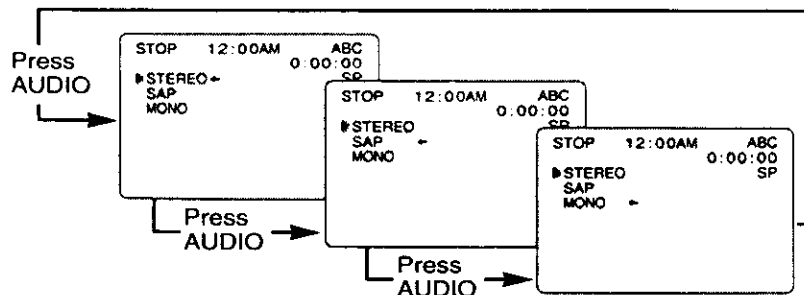

IMPORTANT NOTE:
 <For model PV-M2079 only>
 This stereo system is designed for TV viewing only. Recording and playback will always be in monaural.

Playback a Tape

Model PV-M2079 unit is shown here.

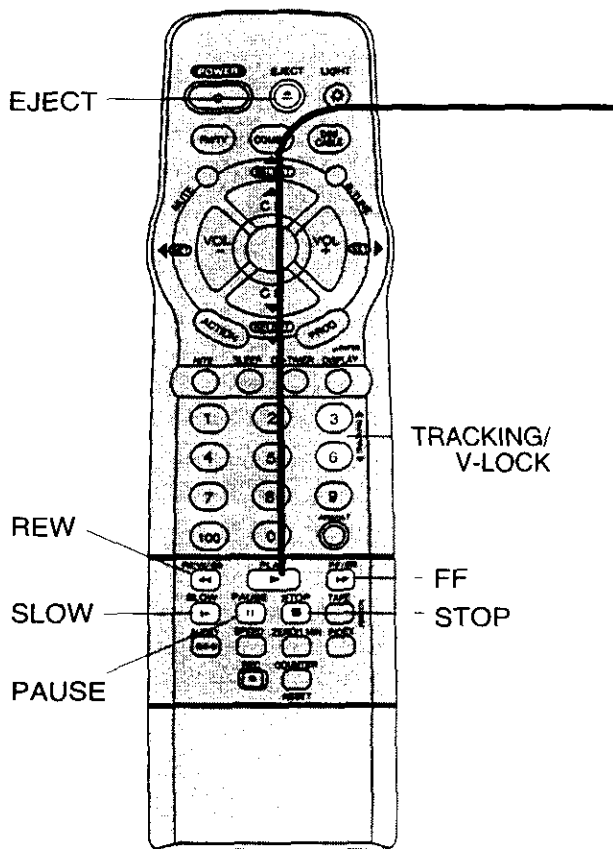
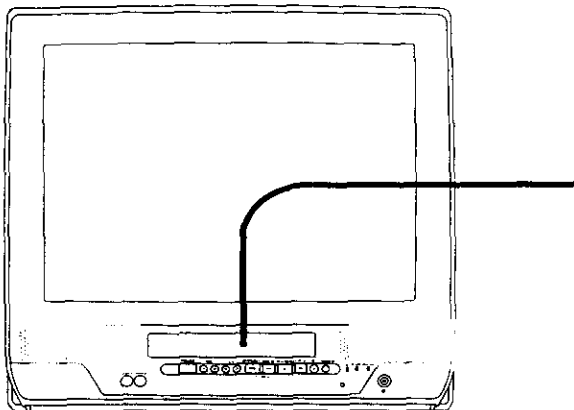

Check list before you begin.

- All connections are made (see page 5.)
- Your Combination VCR is plugged in.

1

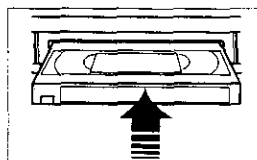

Insert a cassette.

- Combination VCR power comes on automatically.

Note

To prevent tape jam

Inspect your cassette tapes and remove any loose or peeling labels.

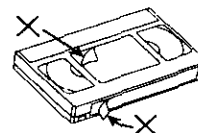

2



Press PLAY.

- Playback begins if cassette has no record tab.

■ To Find a Particular Scene

- Forward Search → Press FF
- Reverse Search → Press REW

■ For view Slow Motion → Press SLOW

(To release, press SLOW)

■ For view Still (Freeze) picture → Press PAUSE

(To release, press PAUSE)

■ For view Frame by Frame picture →

Press SLOW in the Still mode (To release, press PAUSE)

Note

After Combination VCR is in Still or Slow mode for 3 minutes, it will switch to Stop mode automatically to protect the tape and the video head.

■ To stop → Press STOP

■ To rewind tape → Press REW in stop mode

■ To eject tape → Press EJECT on the remote or STOP/EJECT on the Combination VCR

You can operate on the Combination VCR (Model PV-M2079 unit is shown here.)

1 Insert a cassette.

2 Press PLAY.

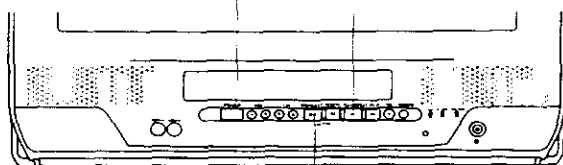

- Press to stop and/or eject tape.

Features for Quality Picture

Digital Auto Tracking

Continuously analyzes the signal and adjusts for optimum picture quality.

Manual Tracking Control (to reduce picture noise)

Use during Playback and Slow Motion mode to reduce picture noise.

Press the 3 or 6 NUMBERED key on the remote control or CH ▲▼* on the Combination VCR until the picture clears up. To return to Auto Tracking, press POWER off, then on again a few seconds later.

V-Lock Control

In Still mode, the 3 or 6 NUMBERED key on the remote control or CH ▲▼ on the Combination VCR operate as a V-Lock control to reduce jitter.

PanaBlack™ Picture Tube

This Combination VCR uses a PanaBlack™ picture tube for better color reproduction and picture contrast.

Record On a Tape

Important: If the remote control POWER, CH Up/Down, NUMBERED keys, ACTION, PROG, DISPLAY, TAPE POSITION, INDEX, ON-TIMER, R-TUNE, FM/TV, and ADD/HLT button does not work when pressed, press COMBO button on the remote and try the button again.

Model PV-M2079 unit is shown here.

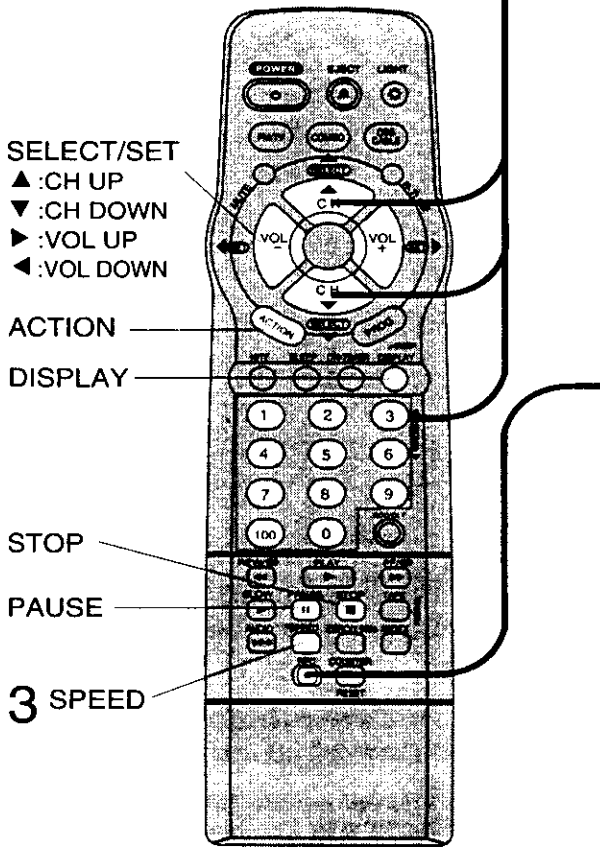
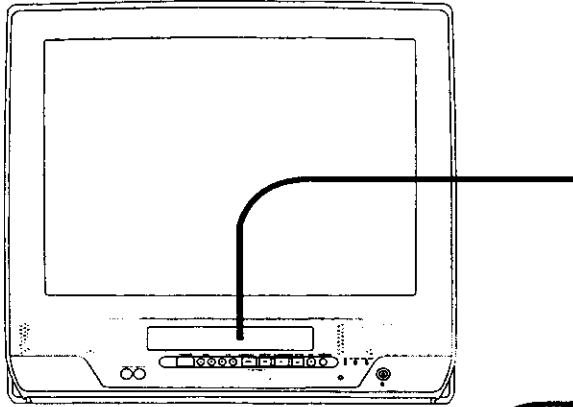

✓ Check list before you begin.

- All connections are made (see page 5.)
- Your Combination VCR is plugged in.
- Cassette with record tab in place.

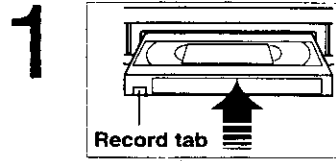

Insert a cassette.

- Combination VCR power comes on automatically.

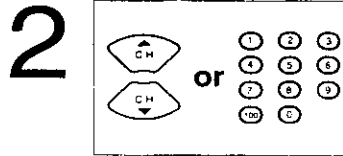

Select Channel.

Press CH ▲▼, or NUMBERED keys.

- To select "LINE," see bottom of this page.



Select Recording speed (see page 4.)

Press SPEED.

- SP = Standard Play
- LP = Long Play
- SLP = Super Long Play

- Selected speed is displayed.



Start Recording.

Press REC.

- To edit out unwanted portions, press PAUSE to pause and resume recording.
- You can not view another channel during recording.

■ To stop → Press STOP

■ One Touch Recording (OTR)

Press REC repeatedly to set the recording length (30 min - 4 hours.)

- Combination VCR stops recording at a preset time.
- PROG TIMER indicator lights on the Combination VCR.

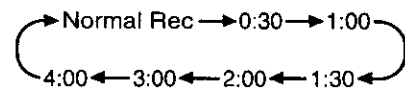

Notes

- After Combination VCR has been in Rec Pause mode for 5 minutes, it will stop automatically to protect the tape and video head.
- The remaining recording time of an OTR can be displayed by pressing DISPLAY.

Selecting Input Mode

Method: 1

Press CH ▲▼. The display will change as follows.

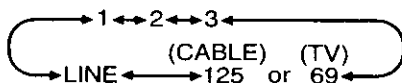

Method: 2

- a Press ACTION for MAIN MENU.
- b Press ▲▼◀▶ to select "TV", then press ACTION for SET UP TV screen.
- c Press ▲▼ to select "INPUT SELECT," and then press ▶ to select "TUNER" or "LINE."
- d Press ACTION twice to exit this mode.

You can operate on the Combination VCR (Model PV-M2079 unit is shown here.)

1 Insert a cassette. **2** REC Indicator

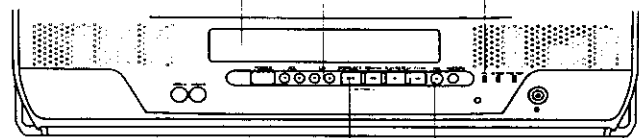

■ Press to stop. **4**

Timer Recording

You can set up to 8 programs to be recorded while you are away.

1



Display SET PROGRAM.
Press PROG*.

2

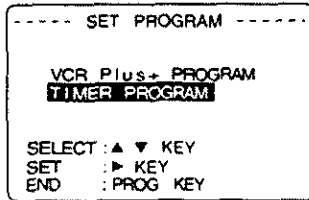

Select TIMER PROGRAM.



- 1) Press ▲▼ to select.
- 2) Press ► to display.

• If a program is already in memory, press ▲▼, and ► to select an unused program number.

3

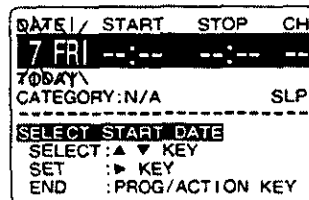

Set the recording DATE.



- 1) Press ▲▼ to select.
- 2) Press ► or ◀ to set.

- 1-31 = One time
- DAILY = MON-FRI
- WEEKLY SUN-SAT = Same time once a week

Example

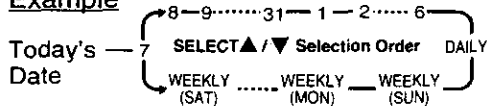

Repeat step 3 to set:

- start time, stop time
- Channel (or LINE for outside source)
- Category [N/A (not applicable), SPORTS, MOVIE, COMEDY, MUSIC, DRAMA]
- Speed (SP, LP, SLP)

4

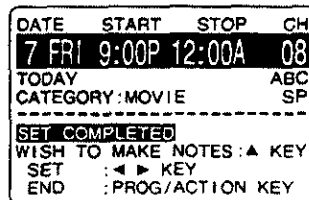

Make the notes.

• If not wanted, go to step 5.



- 1) Press ▲ to begin.
- 2) Press ▲▼ to select.
- 3) Press ► or ◀ to set.
- 4) Press PROG (or ACTION) to end.

• Characters will change in the following order.

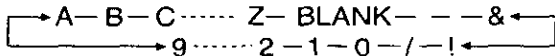

Notes

- If "PLEASE PREPARE FOR TIMER REC" appears and/or the PROGRAM TIMER indicator flashes, check that a cassette with record tab is loaded and the Combination VCR is in Stop mode.
- If the start times of two programs overlap, the lower numbered program will have priority.
- If the start time for a Timer Recording comes up during a normal recording or One Touch Recording (page 11), the Timer Recording will not be performed.
- If there is a power interruption of more than one minute, the recording may not be performed or continue.
- If "INCOMPLETE" appears after all items have been set, check all entries and make necessary corrections.

Continued on the next page.



Check list before you begin.

- All connections are made (see page 5.)
- Your Combination VCR is plugged in.
- The clock is set to correct time.
- The tape is long enough.
- The record tab is in place.

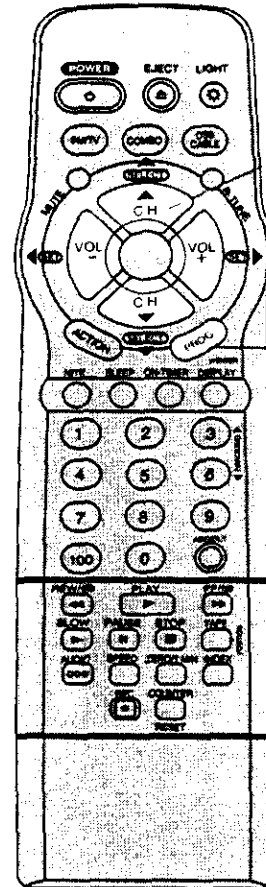

- 2 SELECT/SET
- 3 ▲:CH UP
- 4 ▼:CH DOWN
- ▲:VOL UP
- ◀:VOL DOWN
- 1 PROG
- 4
- 5
- 6

Timer Recording Using Combination VCR Buttons

You can set the Timer Recording using ACTION key on the Combination VCR. (See page 7.)

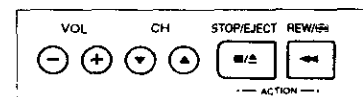

- 1 Press STOP/EJECT and REW together without a tape to display MAIN MENU.
- 2 Press ▲▼◀▶ to select "VCR" and STOP/EJECT and REW together to display SET UP VCR screen.
- 3 Press ▲▼ to select "TIMER PROGRAM" and ► to display the TIMER PROGRAM screen.
- 4 Repeat steps 3-6.

★Important: If the remote control POWER, CH Up/Down, NUMBERED keys, ACTION, PROG, DISPLAY, TAPE POSITION, INDEX, ON-TIMER, R-TUNE, FM/TV, and ADD/DLT button does not work when pressed, press COMBO button on the remote and try the button again.

5

P	DT	START	STOP	CH	SPD
1	day	9:00p	12:00a	08	SP
2	---	---	---	---	---
3	---	---	---	---	---
4	---	---	---	---	---

CANCEL: ADD/DLT KEY
 SELECT 1-8: ▲ ▼ KEY
 ENTER: ► KEY
 END: :PROG/ACTION KEY

End the program.



Press PROG (or ACTION.)

To Enter More Programs

Press ▲▼ and ► to select and set a blank program number, and then repeat steps 3 and 4.

Cancel a Timer

Recording: (Recording is in progress)

Hold down STOP for a few seconds to cancel the Timer Recording.

- Any future daily or weekly recordings will be performed as programmed.

6



Exit this mode.

Press PROG twice (or ACTION.)

- If you're using a cable box, make sure that it is tuned to the desired channel and the power is left on for timer recording.
- PROG TIMER indicator lights on the Combination VCR.

Model PV-M2079 unit is shown here.

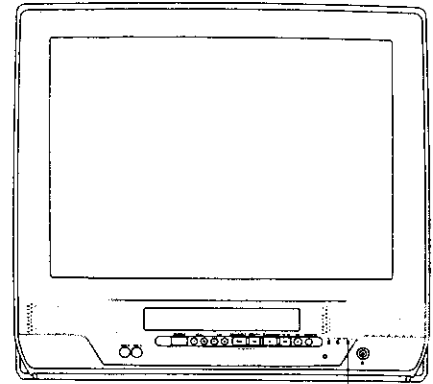

PROG TIMER indicator

Review, Replace or Clear Program Contents: (Recording is not in progress)

a

Repeat steps 1 and 2 on page 12.

b

P	DT	START	STOP	CH	SPD
1	day	9:00p	12:00a	08	SP
2	8	10:00a	12:00p	125	SP
3	10	8:00p	9:00p	10	SP
4	SU	9:00p	10:00p	L	LP

CANCEL: ADD/DLT KEY
 SELECT 1-8: ▲ ▼ KEY
 ENTER: ► KEY
 END: :PROG/ACTION KEY

Select the desired program.

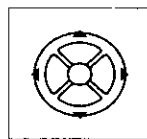

Press ▲▼ to select.

c

To Replace program...

DATE	START	STOP	CH
8 SAT	9:00P	12:00A	08

TODAY: ABC
 CATEGORY: MOVIE
 NOTES: STAND BY ME
 SELECT START DATE
 SELECT: ▲ ▼ KEY
 SET: ◀ ▶ KEY
 END: :PROG/ACTION KEY

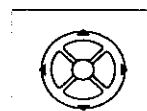

- 1) Press ► to display.
- 2) Press ▲▼◀▶ to set new program contents.
- 3) Press PROG (or ACTION.)



To Clear program...

P	DT	START	STOP	CH	SPD
1	---	---	---	---	---
2	8	10:00p	12:00a	125	SP
3	10	8:00p	9:00p	10	SP
4	SU	9:00p	10:00p	L	LP

SELECT 1-8: ▲ ▼ KEY
 ENTER: ► KEY
 END: :PROG/ACTION KEY

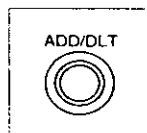

Press ADD/DLT.

d



Exit this mode.

Press PROG twice (or ACTION.)

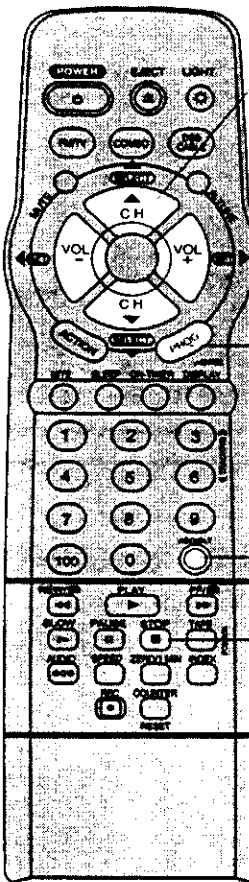

- b SELECT/SET
- c ▲: CH UP
- c ▼: CH DOWN
- c ►: VOL UP
- c ◀: VOL DOWN

c PROG

c ADD/DLT

STOP

Advanced Operation

Timer Programming using VCR Plus+ System

VCR Plus+ System is...

a feature that allows you to set most items of a Timer Recording by simply entering a special code number (PlusCode) found in TV GUIDE and selected newspaper TV listings.

Process of Recording



Choose your connection type from the following diagrams

■ CABLE BOX → COMBINATION VCR

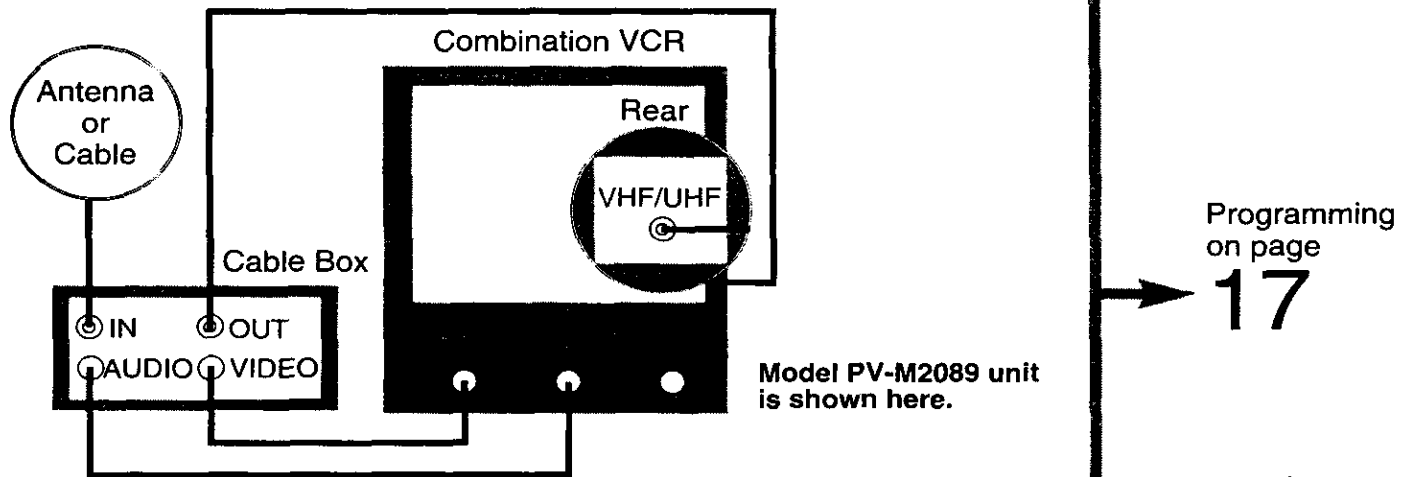
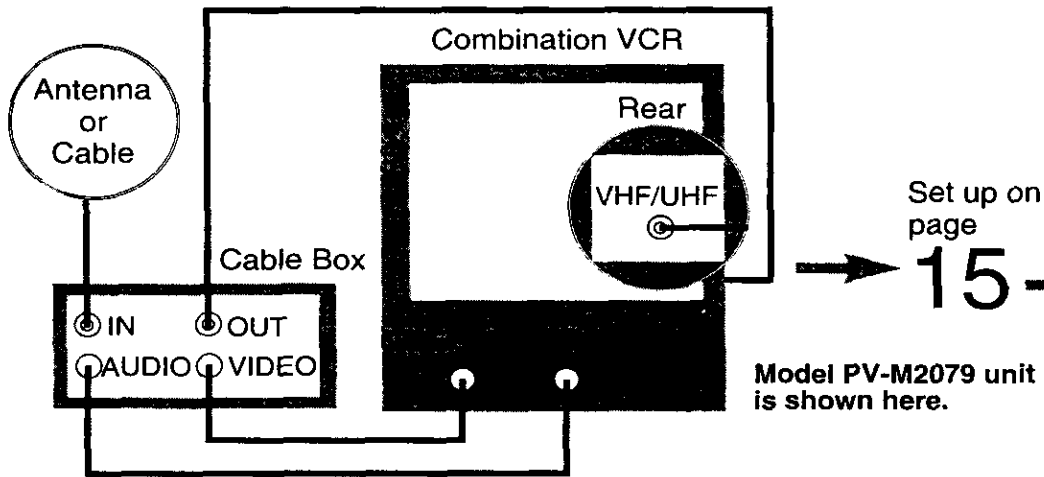

■ ANTENNA or CABLE → COMBINATION VCR

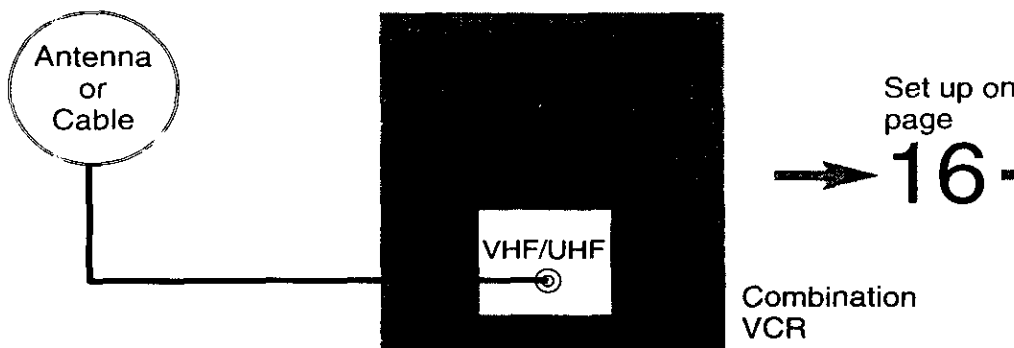

***Important:** If the remote control POWER, CH Up/Down, NUMBERED keys, ACTION, PROG, DISPLAY, TAPE POSITION, INDEX, ON-TIMER, R-TUNE, FM/TV, and ADD/HLT button does not work when pressed, press COMBO button on the remote and try the button again.

Cable Box Setup

Process of Recording

Connection → Setup → Programming

1



Display MAIN MENU.

Press ACTION*.

2

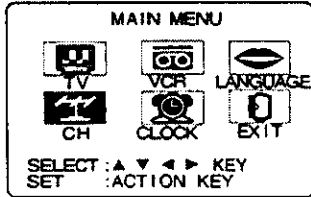

Display SET UP CH screen.

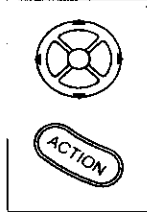

- 1) Press ▲▼◀▶ to select "CH."
- 2) Press ACTION to display.

3

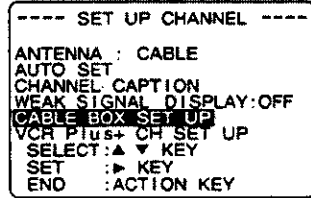

Select CABLE BOX SET UP.

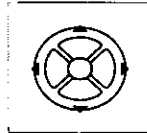

- 1) Press ▲▼ to select number.
- 2) Press ▶ to display.

4

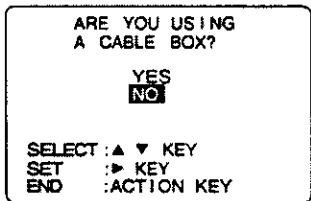

Select "YES" or "NO".

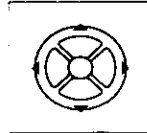

- 1) Press ▲▼ to select "YES" or "NO."
- 2) Press ▶ to set.

If you select...

- "YES" → Step 5.
- "NO" → Press ACTION → Go to VCR Plus+ Channel Setup on page 16.

5

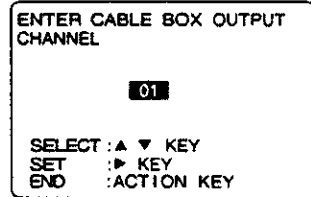

Select Cable box output channel number.

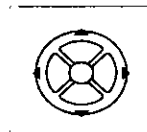

- 1) Press ▲▼ to select.
- 2) Press ▶ to enter.

- If necessary, refer to your cable box manual.
- If you are using Audio/Video jack connection for your cable box, select and set "VIDEO OUT" as the output channel.

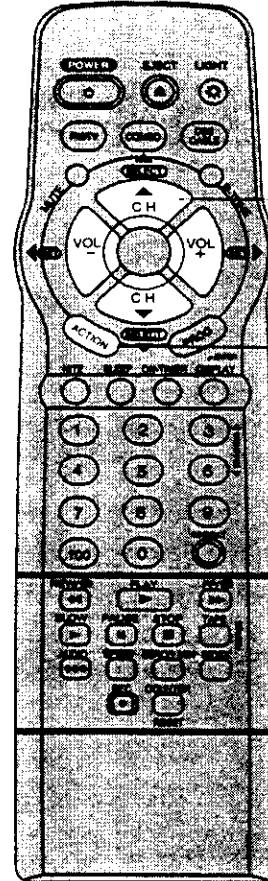

- 2 SELECT/SET
- 3 ▲:CH UP
- 4 ▼:CH DOWN
- 5 ▶:VOL UP
- 6 ◀:VOL DOWN
- 1 ACTION
- 2

Advanced Operation

VCR Plus+ and PlusCode are registered trademarks of Gemstar Development Corporation. The VCR Plus+ system is manufactured under license from Gemstar Development Corporation.

Timer Programming using VCR Plus+ system

VCR Plus+ Channel Setup is...
 necessary to program the Combination VCR with local channel information for proper VCR Plus+ operation.

Process of Recording



VCR Plus+ Channel Setup

At first, do Channel Setup Preparations below right.

1  **Display MAIN MENU.**
 Press ACTION*.

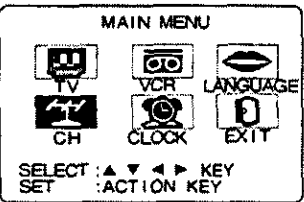
2  **Display SET UP CH screen.**
 1) Press ▲▼◀▶ to select "CH."
 2) Press ACTION to display.

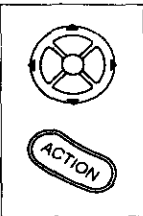

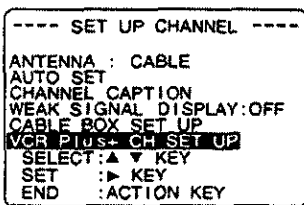
3  **Select VCR Plus+ CH SET UP.**
 1) Press ▲▼ to select.
 2) Press ▶ to display.

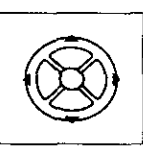

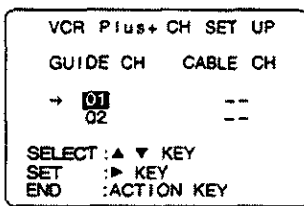
4  **Enter VCR Plus+ channels.**
 1) Press ▶ to move cursor to right column.
 2) Press ▲▼ to change the CABLE CH number.
 3) Press ◀ to set.
 4) Press ▲▼ to scroll up/down the GUIDE CH column.

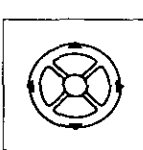

• Repeat step 4 until list is complete.

To Make Corrections

Press ▲▼ and ▶ to move to error, then ▲▼ to change, or ADD/DLT to erase number.

5  **End the setup.**
 Press ACTION three times.

Notes

- Make each entry within 5 minutes or the Combination VCR will leave this mode.
- Once local channels have been programmed, they will stay in memory, even in the case of a power failure.

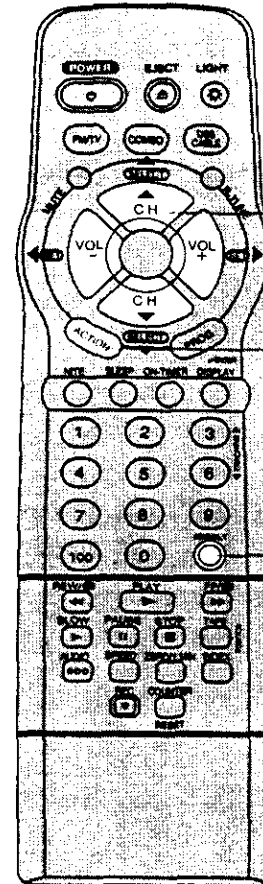

- 2 SELECT/SET
 3 ▲:CH UP
 ▼:CH DOWN
 4 ▶:VOL UP
 ◀:VOL DOWN
 1 ACTION
 2
 5
 ADD/DLT

Channel Setup Preparations

To complete step 4 left, make a local channel list (see example below.)

You will need the following:

- A normal TV and/or Cable stations line up and the channel numbers you receive them on.
- A list of Guide (VCR Plus+) channel numbers for stations you receive (see TV Guide and selected newspapers.)

- 1 Make a 3-column chart. In the left column, write all station names you receive.
- 2 In the middle column, write each station's Guide (VCR Plus+) number.
- 3 In the right column, write the channel number your TV receives the station on.

< EXAMPLE ONLY >

Broadcast or Cable Station Name	Assigned Guide (VCR Plus+) Channel No.	Channel No. your TV receives the station on
HBO	33	15
Nickelodeon	38	20
CBS	34	04
FOX	11	

★Important: If the remote control POWER, CH Up/Down, NUMBERED keys, ACTION, PROG, DISPLAY, TAPE POSITION, INDEX, ON-TIMER, R-TUNE, FM/TV, and ADD/DLT button does not work when pressed, press COMBO button on the remote and try the button again.

VCR Plus+ System Programming

Process of Recording

Connection → Setup → **Programming**

1



Display SET PROGRAM.

Press PROG.

2

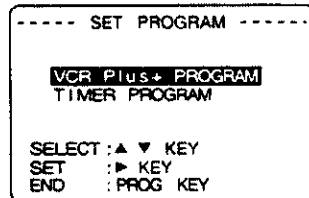

Select VCR Plus+ PROGRAM.

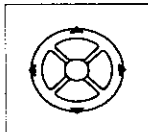

- 1) Press ▲▼ to select.
- 2) Press ► to display.

3

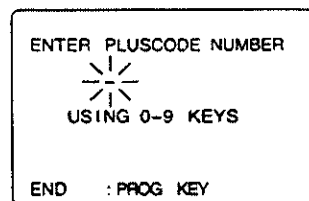

Enter PlusCode programming number.

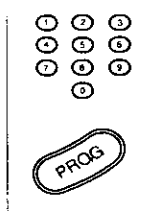

- 1) Press NUMBERED keys.
- 2) Press PROG when finished.

To Make Corrections

Press ◀ repeatedly to delete the PlusCode programming number.

4

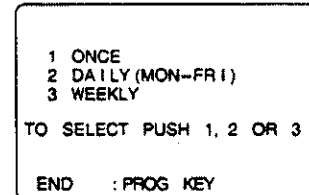

Set Record Frequency.

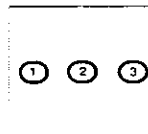

- Press 1, 2 or 3 to set.
- 1 → One time
 - 2 → Daily
 - 3 → Weekly

5

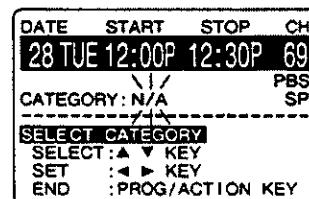

Set Category and Record Speed.

• If want, make the notes (see page 12.)

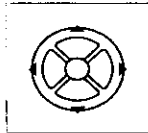

- 1) Press ▲▼ to select.
- 2) Press ► to set.

Select desired type:

- Categories → N/A (not applicable), SPORTS, MOVIE, COMEDY, MUSIC, or DRAMA
- Speed → SP, LP, or SLP

To Make Corrections

Press ◀▶ to move the cursor and ▲▼ to make the correction.

6

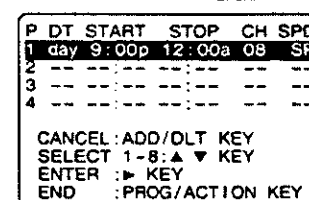

End programming.



Press PROG (or ACTION.)

7



Exit this mode.

Press PROG twice (or ACTION.)

- PROG TIMER indicator lights on the Combination VCR.

Before you begin, make sure...

- The clock is set to correct time.
- VCR Plus+ System Setup is complete (See pages 15, 16.)

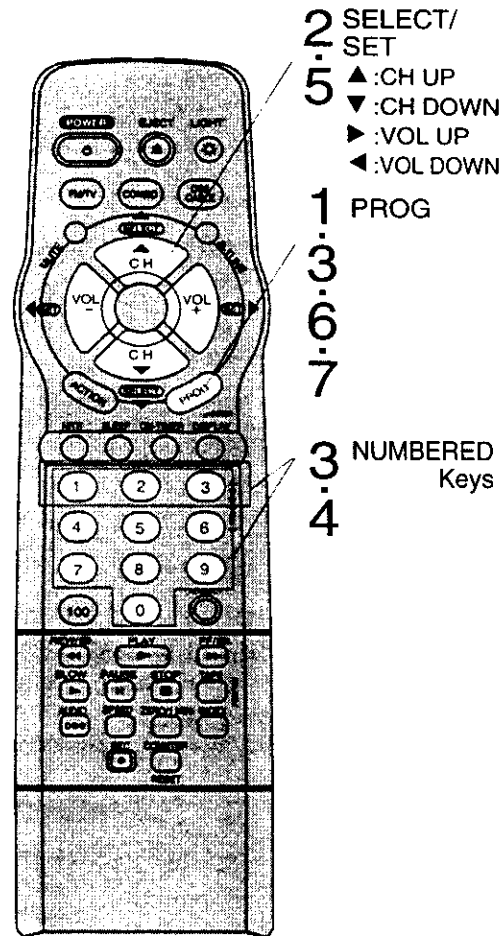

Advanced Operation

Use normal Timer Recording steps if:

- a program PlusCode programming number is not listed.
- program, such as sporting event, may run over scheduled stop time.

See page 13 to:

- cancel a timer recording in progress.
- replace program contents.
- review or clear program contents once set.

Notes

- You can obtain unlisted PlusCode programming numbers by calling 1-900-454-7587. Call costs approximately \$.95 per minute.
- Avoid overlapping program times.
- If you're using a cable box, make sure that it is tuned to the desired channel and the power is left on for timer recording.

TV Timer Features

ON-TIMER with Alarm

Combination VCR can be set to automatically power on in one of 3 modes (TV, Playback, or FM radio.) You can also combine the On-Timer with a one minute alarm that gradually increases in volume.

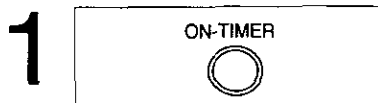

Display ON TIMER screen.

Press ON-TIMER*.

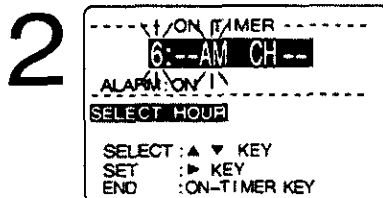

Set the ON-TIMER DATE.

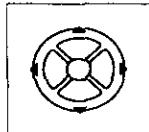

- 1) Press ▲▼ to select.
- 2) Press ► to set.

- Make sure a tape is inserted if Playback mode is selected.
- See "FM Radio Setup" on page 22 and 23 for instructions on how to preset FM stations.

- ON-TIMER mode selection order

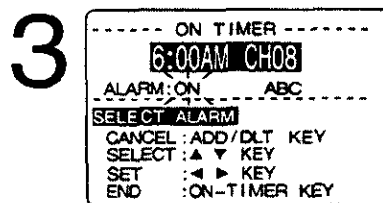
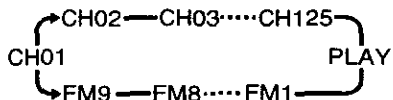

Set Alarm.



Press ▲▼ to select "ON" or "OFF."

When "ON" is selected, an alarm will gradually increase in volume for one minute or until cancelled by pressing any button (including VOL ◀▶.)

To Make Corrections, use ▲▼ and ◀▶ to move back and correct as necessary.

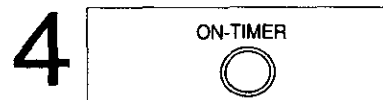

Set ON TIMER.

Press ON-TIMER.

- ON TIMER indicator lights on the Combination VCR.

To cancel ON-TIMER set, press ON-TIMER to redisplay the screen in step 3. Then, press ADD/HLT to clear the time ("6" is flashing.) Now, press ON-TIMER to end. "ON TIMER END" appears on-screen for a few seconds.

Note

If no button on the remote or Combination VCR (including a button used to turn off the alarm) is pressed within 60 minutes after Combination VCR turns itself on, it will turn itself back off.

Check list before you begin.

- The clock is set to correct time.

Model PV-M2079 unit is shown here.

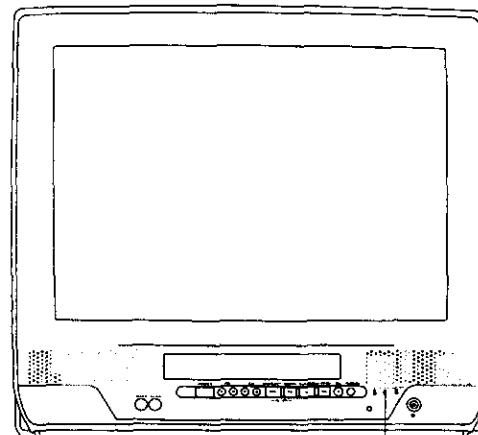

ON TIMER Indicator

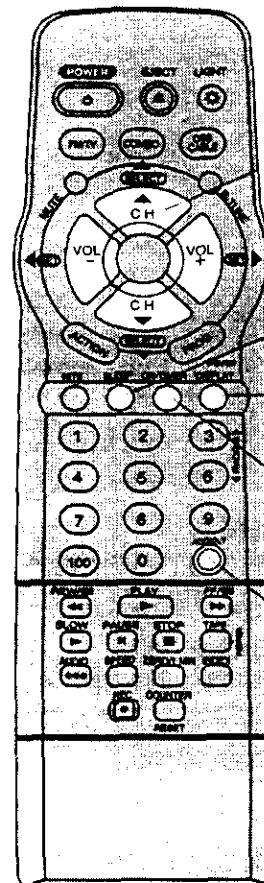

- 2 SELECT/SET
- 3 ▲:CH UP
▼:CH DOWN
▶:VOL UP
◀:VOL DOWN
- SLEEP
- DISPLAY
- 1 ON-TIMER
- 4 ADD/HLT

SLEEP TIMER

Combination VCR can be set for auto power off.

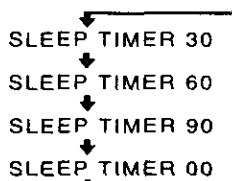

Set SLEEP TIMER.

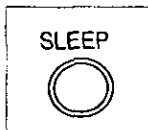

Press SLEEP repeatedly.

- Pressing DISPLAY with sleep timer set displays remaining time.

To Cancel, press SLEEP repeatedly until "SLEEP TIMER 00" appears.

***Important:** If the remote control POWER, CH Up/Down, NUMBERED keys, ACTION, PROG, DISPLAY, TAPE POSITION, INDEX, ON-TIMER, R-TUNE, FM/TV, and ADD/HLT button does not work when pressed, press COMBO button on the remote and try the button again.

INSTANT ALARM

The feature allows you to set a timer alarm for up to 60 minutes. Useful for when you are cooking and need to leave the kitchen.

1

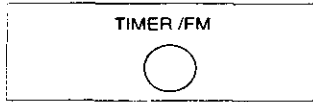

Display INSTANT ALARM screen.

Press TIMER/FM on the Combination VCR to display.

2

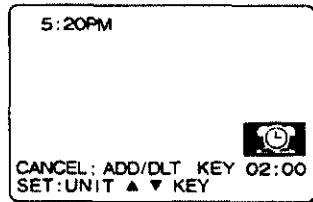

Set Alarm.

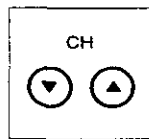

Press CH ▲▼ on the Combination VCR to select time (see below.)

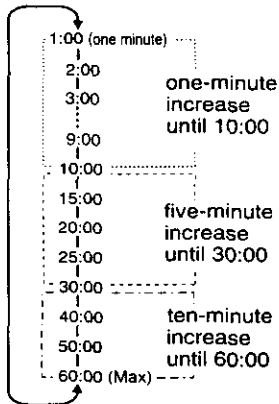

- Countdown starts 3 seconds after alarm is set.

To cancel, press ADD/HLT.

To increase timer in progress, Press CH ▲▼ to restart countdown rounded up to next 1, 5, or 10 minute interval.

<Example>

- If current time remaining is 12:15, countdown will restart from 15:00.
- If current time remaining is 9:15, countdown will restart from 10:00.

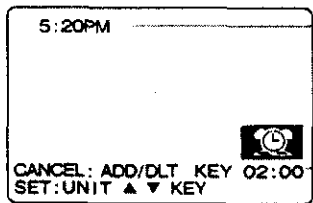

— The current time (if clock is set) and time remaining display change positions on the screen every 10 seconds.

— Remaining Time

3

Alarm will go off at 0:00.

Press any button to stop.

- The volume of the alarm gradually increases for one minute and then continues to beep until any button is pressed.

Note

When watching TV while INSTANT ALARM is in progress, only use CH ▲▼ on remote to change channels.

Model PV-M2079 unit is shown here.

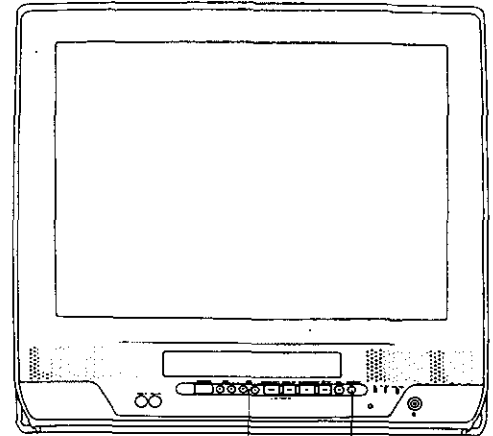

2 CH ▲▼ 1 TIMER/FM

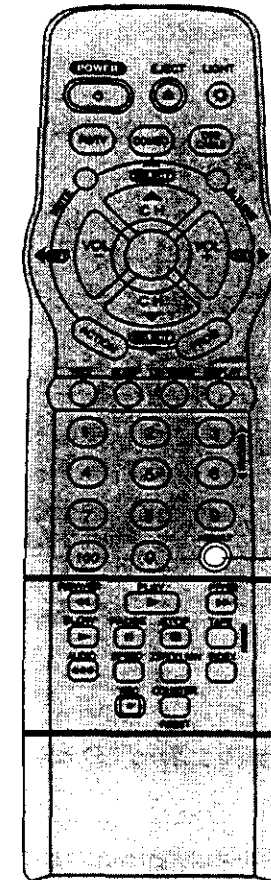

ADD/HLT

Advanced Operation

Closed Caption System

Closed Caption Mode Feature

1



Display MAIN MENU.
Press ACTION*.

2

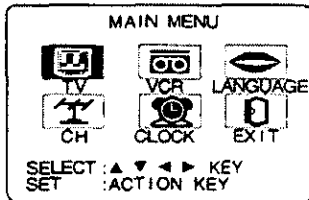

Display SET UP TV screen.

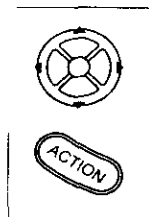

- 1) Press ▲▼◀▶ to select "TV."
- 2) Press ACTION to display.

3

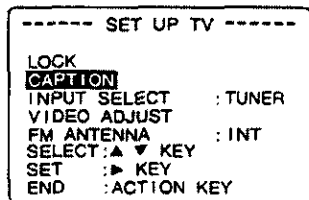

Display CAPTION screen.

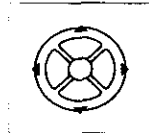

- 1) Press ▲▼ to select.
- 2) Press ▶ to display.

<For Model PV-M2079 only>

4

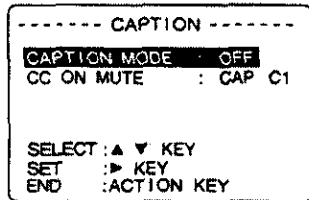

Select CAPTION MODE.

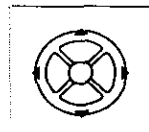

- 1) Press ▲▼ to select.
- 2) Press ▶ repeatedly to select caption mode.

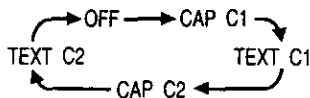

5



Return to the normal screen.
Press ACTION three times.

Closed Caption is ...

This multi-use system not only allows the hearing impaired to enjoy selected programs, but also makes useful information from TV stations available to everyone.

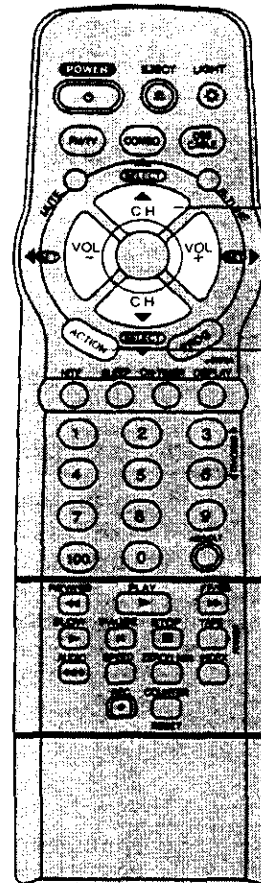

- 2 SELECT/SET
- 3 ▲:CH UP
- 3 ▼:CH DOWN
- 4 ▶:VOL UP
- 4 ◀:VOL DOWN
- 1 ACTION
- 2
- 5

Recording and Playing Back a Closed Caption/Text Program

Record:

Record normally. Closed Caption/Text signal, if present, is recorded automatically.

Playback:

Start playback. Do above steps to select desired caption mode.

Closed Caption Modes From which to Choose

Caption Mode: CAP C1 or C2

A narration of selected TV programs is displayed.

Check TV program listings for C.C. (Closed Caption) broadcasts.

Caption Mode: TEXT C1 or C2

The lower half of the screen will be blocked out. When the TV station broadcasts information, such as program listings, it will appear in this space.

Caption Mode: OFF

Closed Caption/Text narration will not be displayed.

NOTE:

The closed caption or text signal may be broadcast over C1, C2, or both. Also, text contents can vary so you may wish to try different settings.

★Important: If the remote control POWER, CH Up/Down, NUMBERED keys, ACTION, PROG. DISPLAY, TAPE POSITION, INDEX, ON-TIMER, R-TUNE, FM/TV, and ADD/HLT button does not work when pressed, press COMBO button on the remote and try the button again.

Caption On Mute Feature

Closed Caption narration, if available, is displayed when MUTE button is pressed for silence.

1  **Display MAIN MENU.**
Press ACTION.

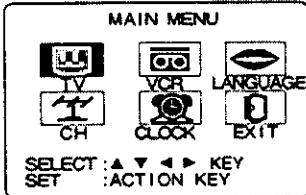
2  **Display SET UP TV screen.**
1) Press ▲▼◀▶ to select "TV."
2) Press ACTION to display.

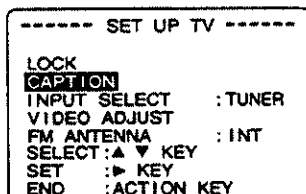
3  **Display CAPTION screen.**
1) Press ▲▼ to select.
2) Press ▶ to display.

<For Model PV-M2079 only>

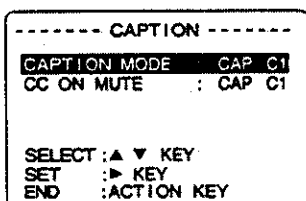
4  **Set CAPTION MODE OFF.**
1) Press ▲▼ to select.
2) Press ▶ repeatedly to select "OFF."

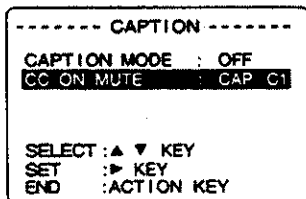
5  **Select CC ON MUTE.**
1) Press ▲▼ to select.
2) Press ▶ repeatedly to select desired caption mode.

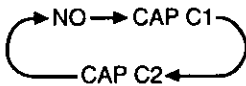

- Each press of ▶ will change the display as shown at left.
- The caption may be broadcast over CAP C1 or C2.

6  **Return to the normal screen.**
Press ACTION three times.

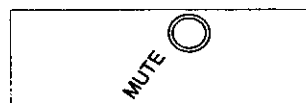
7  **Mute sound, display closed captioning.**
Press MUTE to mute the sound.
• To cancel, press MUTE again.

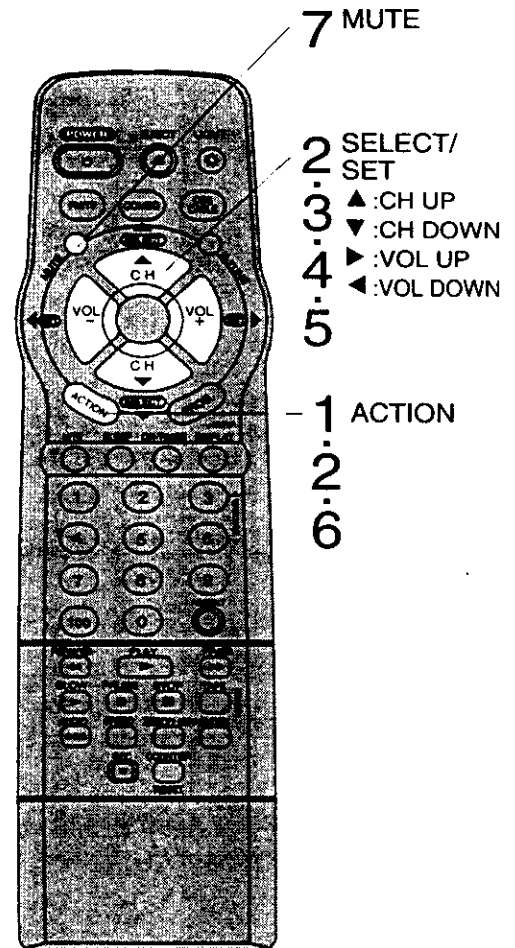

FM Radio

FM Radio is...

The Combination VCR has an FM radio with built-in antenna, 9 station preset, and a band range of 87.5~108.1 MHz. You can even set the On-Timer (page 18) to wake up to your favorite music station.

FM ANTENNA Setup

1  **Display MAIN MENU.**
Press ACTION*.

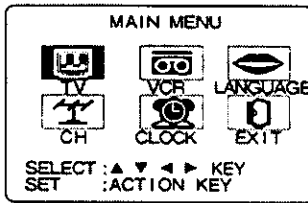
2  **Display SET UP TV screen.**
1) Press ▲▼◀▶ to select "TV."
2) Press ACTION to display.

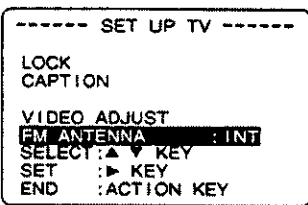
3  **Select FM ANTENNA.**
1) Press ▲▼ to select.
2) Press ▶ for "INT (INTERNAL)" or "EXT (EXTERNAL)."

<For Model PV-M2079 only>

- If you do not have a cable box → "INT"
- If you have a cable box → "EXT"

Note

If, due to the cable box used, you do not receive the desired radio station during FM radio Setup (page 23), please select FM ANTENNA: "INT."

4  **End setup.**
Press ACTION twice to exit.

FM Radio Setup

a  **Display FM radio mode.**
Press FM/TV on the remote or TIMER/FM twice on the Combination VCR.

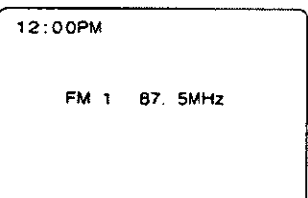
b  **Select the FM number.**
Press a NUMBERED key (1~9.)

Continued on the next page.

Process of FM Radio

Antenna → Setup → Using

Model PV-M2079 unit is shown here.

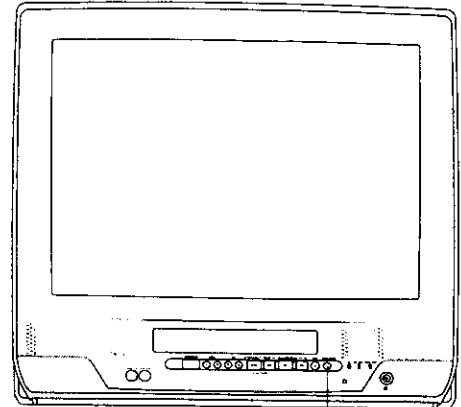

a TIMER/FM

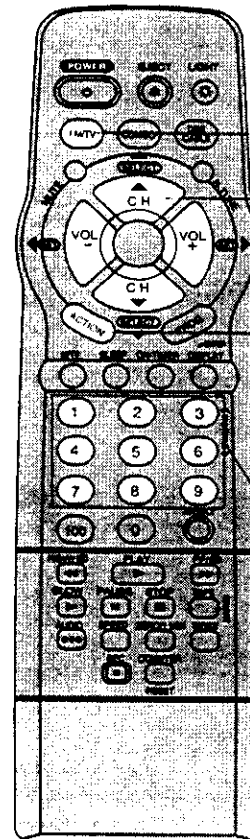

- a FM/TV
- 2 SELECT/SET
- ▲: CH UP
- ▼: CH DOWN
- 3 ▶: VOL UP
- ◀: VOL DOWN
- 1 ACTION
- 2
- 4
- b NUMBERED Keys

Notes

- If INDEX is pressed while in the FM radio mode, you will not be able to select other stations with the NUMBERED keys.
- FM radio stations cannot be recorded on a Video cassette.
- You may get better reception by repositioning the Combination VCR.
- You cannot select FM Radio mode during playback or record, or while a blue back screen (ACTION, PROG, and ON-TIMER) is displayed.

★Important: If the remote control POWER, CH Up/Down, NUMBERED keys, ACTION, PROG, DISPLAY, TAPE POSITION, INDEX, ON-TIMER, R-TUNE, FM/TV, and ADD/DLT button does not work when pressed, press COMBO button on the remote and try the button again.

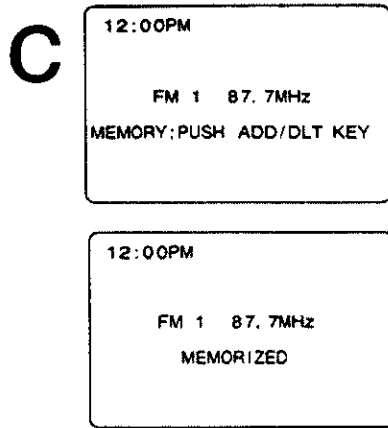

Set the radio station.

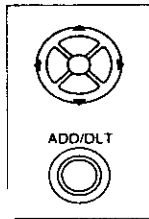

- 1) Press ▲▼ to select the desired radio station. (Each press changes frequency 200 KHz.)
- 2) Press ADD/DLT to set.

Quick Station Scan

Hold down ▲ or ▼ more than 1 second, then release to scan for FM stations in your area.
 • To cancel, press ▲ or ▼ while in search mode.

To Make Corrections, select station with a NUMBERED key, then do step c again.

To exit FM mode, press FM/TV on the remote or TIMER/FM twice on the Combination VCR.

Process of FM Radio



Model PV-M2079 unit is shown here.

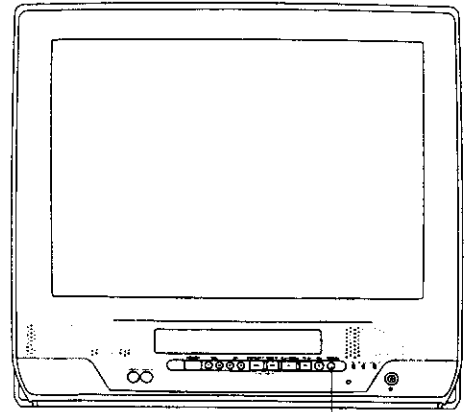

A TIMER/FM

Using FM Radio

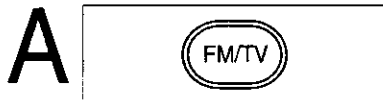

Display FM radio mode.

Press FM/TV on the remote and TIMER/FM twice on the Combination VCR.

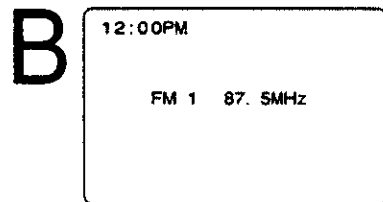

Select the FM number.

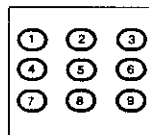

Press a NUMBERED key (1~9) to select a preset station (see steps b and c.)

To cancel, press FM/TV on the remote or TIMER/FM twice on the Combination VCR.

Note

Once stations are set, the selected station and current time are displayed when FM radio mode is entered. The station disappears in 10 seconds.

To remove time, press DISPLAY. If DISPLAY is pressed while station is still on the screen, or when there is no display, the Combination VCR status screen appears.

To select Audio Mode for FM Radio

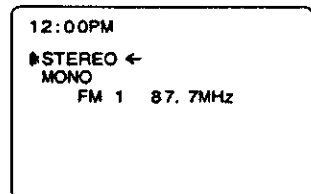

Select "STEREO" or "MONO."



Press AUDIO repeatedly in FM Radio mode.

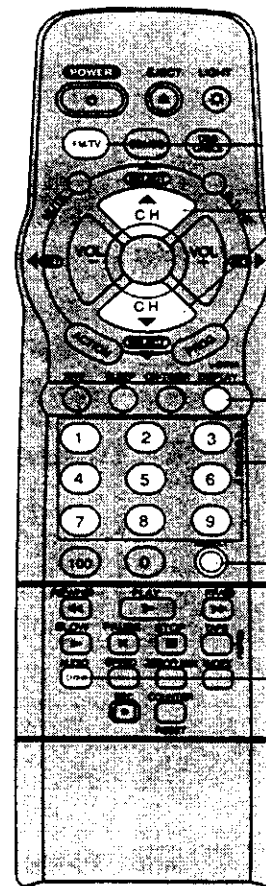

Advanced Operation

Tape Operation

Tape Position Display

To find out the present tape position.
Tape position cannot be found for C-Cassette type and tape of less than 60 minutes.

1  **Detect Tape Position.**
 Press TAPE POSITION*.

DETECTING TAPE POSITION

- "DETECTING TAPE POSITION" is displayed only when first cassette in.
- It takes several seconds for correct tape position to appear.

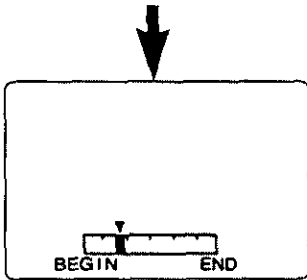

- Indication is standard.

2  **Return to normal screen.**
 Press TAPE POSITION.

Zero Search

To quickly return to a specific tape counter location.

a  **Display the Counter.**
 Press DISPLAY during playback.

b  **Reset to "0:00:00."**
 Press COUNTER RESET at the desired position.

<For model PV-M2079 only>

c **Continue playback, rewind, or fast forward.**

d  **Return to "0:00:00."**
 Press ZERO/1 MIN in Stop mode.

- The Combination VCR will go into FF or REW mode and stop at the last point the Counter was set to 0:00:00.

<For model PV-M2079 only>

Your Combination VCR is equipped with several time saving features as well as convenient automatic functions which make tape operation easier than ever.

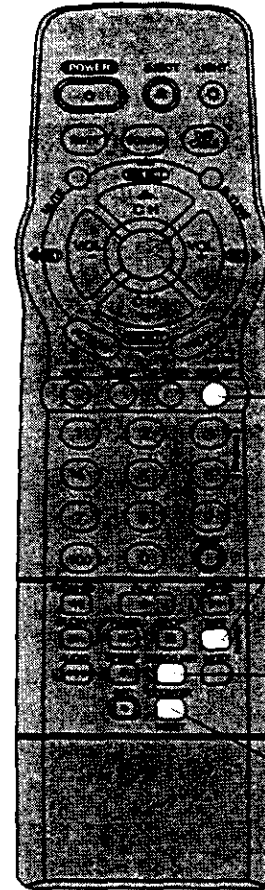

a DISPLAY

1 TAPE POSITION

2

d ZERO/1 MIN

b COUNTER RESET

★ Important: If the remote control POWER, CH Up/Down, NUMBERED keys, ACTION, PROG, DISPLAY, TAPE POSITION, INDEX, ON-TIMER, R-TUNE, FM/TV, and ADD/DLT button does not work when pressed, press COMBO button on the remote and try the button again.

Repeat Play

Set to see a recording over and over.

1



Display MAIN MENU.
Press ACTION.

2

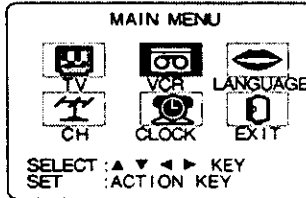

Display SET UP VCR screen.

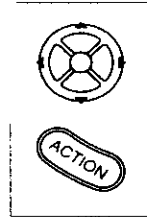

- 1) Press ▲▼◀▶ to select "VCR."
- 2) Press ACTION to display.

3

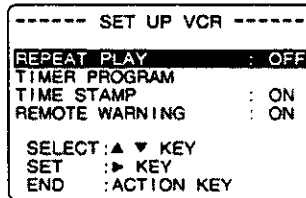

Select REPEAT PLAY.

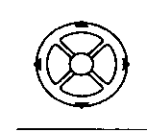

- 1) Press ▲▼ to select.
- 2) Press ▶ to set "ON" or "OFF."

Notes

- Playback repeats when tape end is reached or unrecorded portion over 30 seconds is detected.
- During playback, you may also press PLAY/REPEAT repeatedly on the Combination VCR to select REPEAT "ON" or "OFF."

4



End setup.
Press ACTION twice.

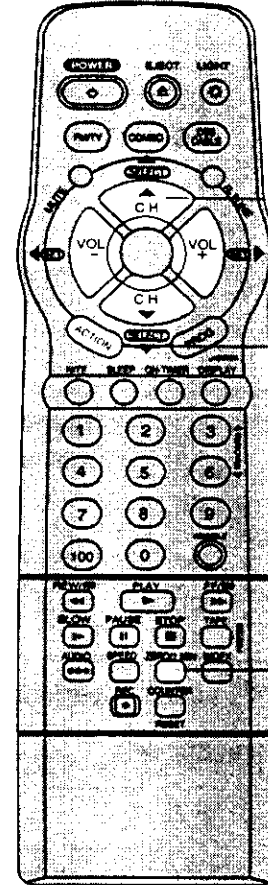

2 SELECT/SET
▲: CH UP
▼: CH DOWN
▶: VOL UP
◀: VOL DOWN

1 ACTION

2
4

— ZERO/1 MIN

Advanced Operation

Auto Operation Functions

■ Auto Shut Off

No broadcast signal in TV, NITE or Playback mode for 5 minutes → Turn Power off automatically

- This feature is deactivated if any button is pressed during the above mode.

■ Auto Playback

Insert a tape in Power off mode → Turn Power on automatically

- Playback begins automatically if a tape has no record tab.

■ Auto Rewind

A tape reaches its end → Rewind begins → Stop automatically

■ Playback Auto Eject (Repeat Play is "OFF")

A tape has no record tab reaches its end → Rewind begins → Eject automatically

■ Memory Rewind off

Press POWER in REW mode → Rewind is completed → Turn Power off automatically

One Minute Skip

Combination VCR fast forwards over 60 seconds of recorded tape.



Skip over 1 minute.

Press ZERO/1 MIN in Playback mode.

Tape Operation (continued)

Direct Access (For Normal and/or Timer recordings)

Go directly to the desired recording.

1



Display INDEX screen.

Press INDEX* in Playback or Stop mode.

- If there are no Timer Recordings on the Program Index List, go to step 3.

2

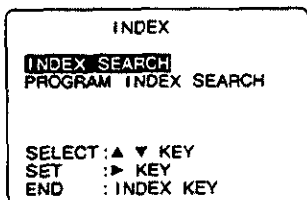

Display INDEX screen.



- 1) Press ▲▼ to select "INDEX SEARCH."
- 2) Press ► to display.

- This screen appears only if there are Timer Recordings.

3

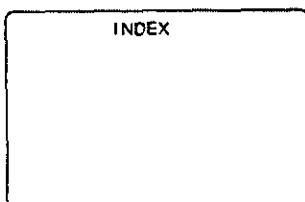

Select the recording number.

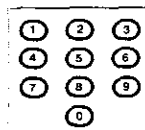

Press NUMBERED keys.

- To calculate number, see below.

4

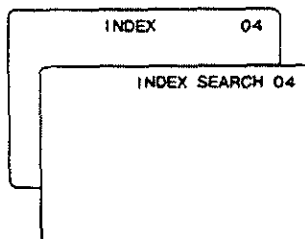

Start search.

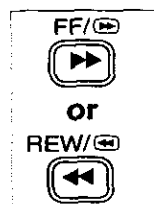

Press FF or REW.

- When search is finished, playback begins.

To calculate the Index Number

Example 1:

If you are watching recording 4 and you want to watch recording 2, enter 3 in step "3" and press REW.

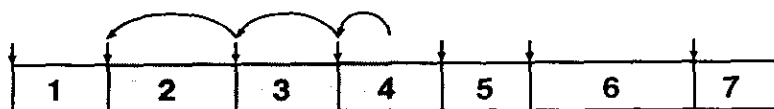

Example 2:

If you are watching recording 2 and you want to watch recording 6, enter 4 in step "3" and press FF.

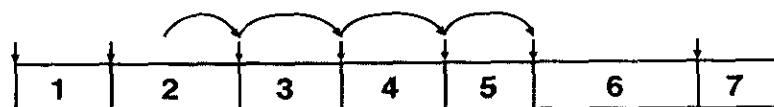

NOTE: ↓ indicates start points of each recording.

VHS Index Search System is ...

Each time recording is made, an invisible index mark is placed on the tape. When timer recordings are made, program index and information are also included. These index marks can be used to access or scan recordings.

Model PV-M2079 unit is shown here.

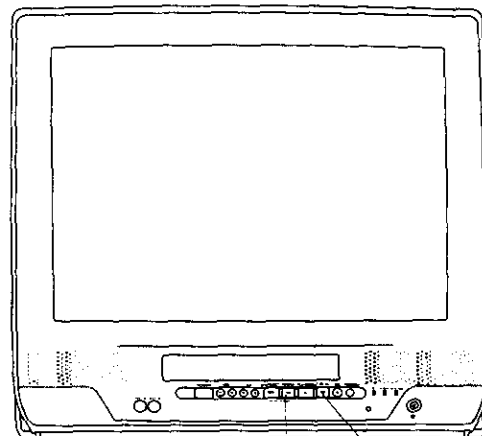

4 REW 4 FF

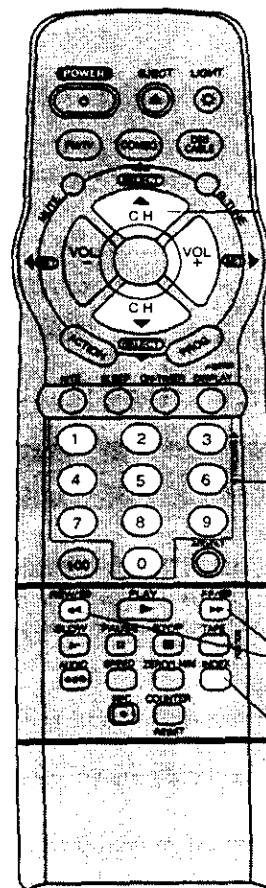

2 SELECT/SET
▲: CH UP
▼: CH DOWN
►: VOL UP

3 NUMBERED keys

4 FF or REW

1 INDEX

Notes

- Make each entry within 10 seconds, or the Index Search mode will be canceled.
- If these VHS Index Search Systems are started very close to an index mark, that index mark may not be counted in the search.

★ Important: If the remote control POWER, CH Up/Down, NUMBERED keys, ACTION, PROG, DISPLAY, TAPE POSITION, INDEX, ON-TIMER, R-TUNE, FM/TV, and ADD/HLT button does not work when pressed, press COMBO button on the remote and try the button again.

Program Index Search (For Timer recordings only)

Choose a timer recorded program from a Program index List. When the tape is ejected or normal recording is started, all program index data are deleted.

1  **Display INDEX screen.**
Press INDEX in Playback or Stop mode.

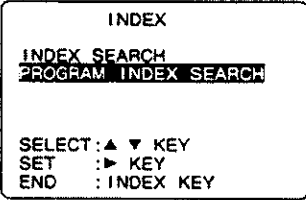
2  **Display PROGRAM INDEX screen.**
1) Press ▲▼ to select "PROGRAM INDEX SEARCH."
2) Press ► to display.

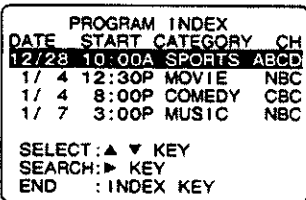
3  **Select the desired recorded program.**
1) Press ▲▼ to select.
2) Press ► to start the forward or rewind search.
• When search is finished, playback begins.

Model PV-M2079 unit is shown here.

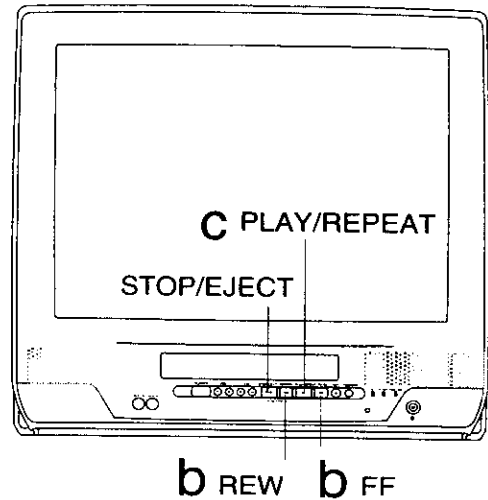

Advanced Operation

Index Scan (For Normal and/or Timer recordings)

In Play mode, the first 10 seconds of each recording can be scanned (forward or reverse.)

a Repeat steps 1 and 2 on previous page to display INDEX screen.

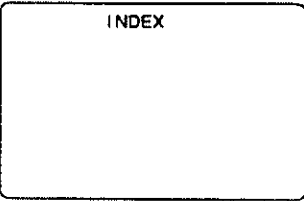
b  **Start the scan.**
Press FF or REW.

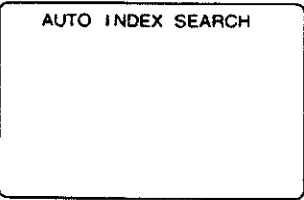
c  **Cancel scan, start playback.**
Press PLAY.
• To stop, press STOP.

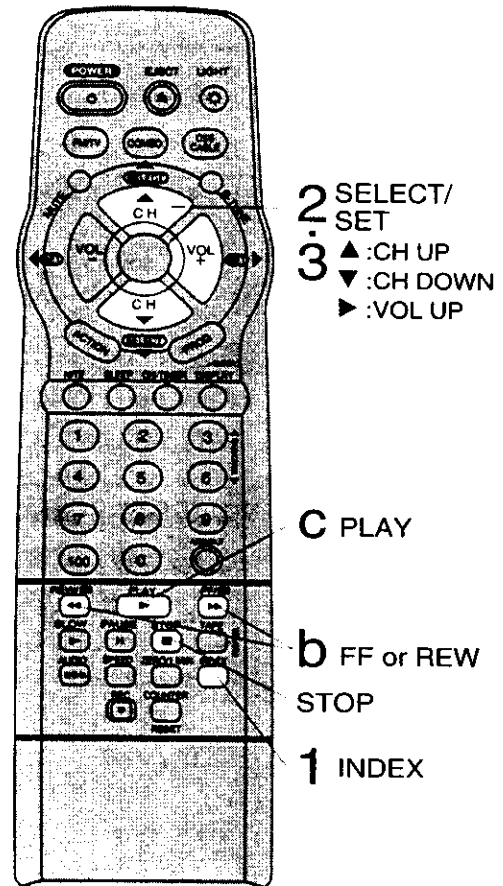

<Example>

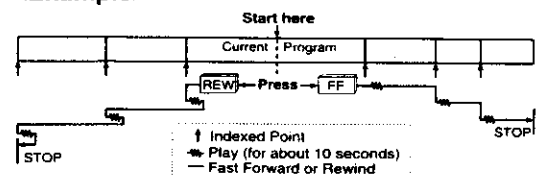

Special VCR Features

Preset Caption

1



Display MAIN MENU.

Press ACTION*.

2

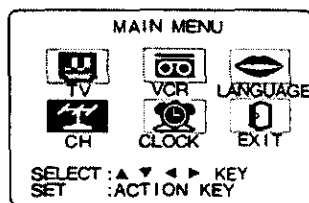

Display SET UP CH screen.

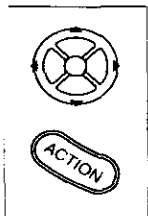

- 1) Press ▲▼◀▶ to select "CH."
- 2) Press ACTION to display.

3

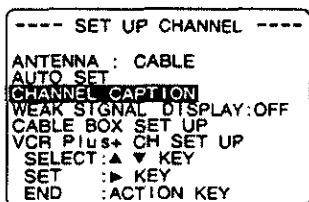

Select CHANNEL CAPTION.

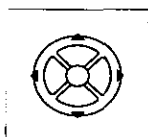

- 1) Press ▲▼ to select.
- 2) Press ▶ to display.

4

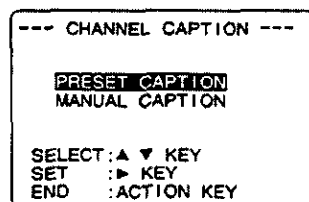

Select PRESET CAPTION.

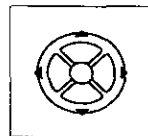

- 1) Press ▲▼ to select.
- 2) Press ▶ to display.

• To create your own captions, go to "Manual Caption" on page 29.

5

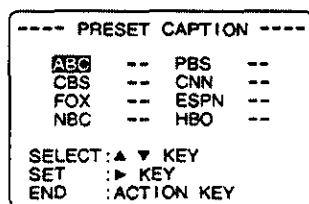

Go with preset captions.

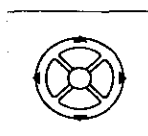

- 1) Press ▲▼ to select a station.
- 2) Press ▶ to move cursor to the right.
- 3) Press ▲▼ to select channel number.
- 4) Press ◀ to set.

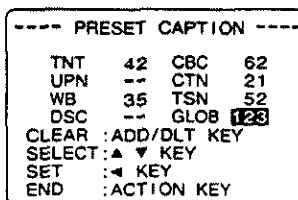

• Repeat step 5 until the Caption List is complete.

To Make Corrections

Press ▲▼, then ▶ to select channel number. Press ▲▼ to change, or ADD/HLT to delete.

6



End setup.

Press ACTION four times.

Channel Caption is ...

Station names, e.g. ABC, TNT, etc. can be set so they will appear when a channel is selected. Choose 24 preset names (Preset Caption), or make up to 10 names of your own (Manual Caption).



Check list before you begin.

- You need a list of stations and the channel numbers you receive them on.

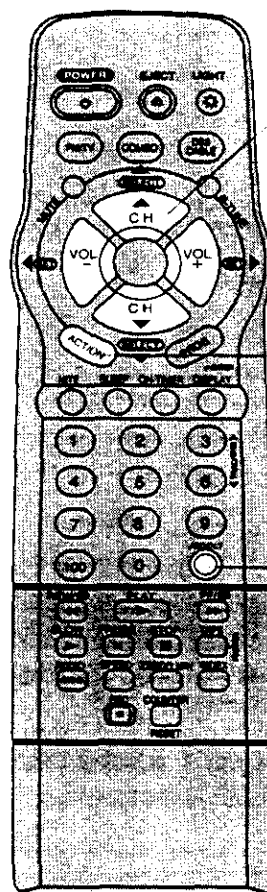

- 2 SELECT/SET
3 ▲:CH UP
4 ▼:CH DOWN
5 ▶:VOL UP
6 ◀:VOL DOWN

1 ACTION

2
3
4
5
6

ADD/HLT

★ Important: If the remote control POWER, CH Up/Down, NUMBERED keys, ACTION, PROG, DISPLAY, TAPE POSITION, INDEX, ON-TIMER, R-TUNE, FM/TV, and ADD/DLT button does not work when pressed, press COMBO button on the remote and try the button again.

Manual Caption

1 Do "Preset Caption" steps 1~3 (page 28.)

2 Select MANUAL CAPTION.

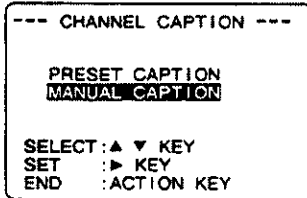

- 1) Press ▲▼ to select.
- 2) Press ► to display.

3 Select Channel number.

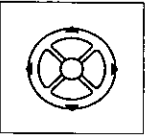
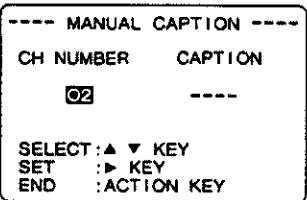

- 1) Press ▲▼ to select CH NUMBER.
- 2) Press ► to move cursor to the right.

- Channels already set and channels deleted from Channel Memory are not displayed.
- You can set a total of ten channel captions with up to four characters each.

4 Enter your caption.

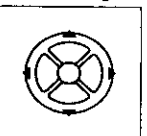
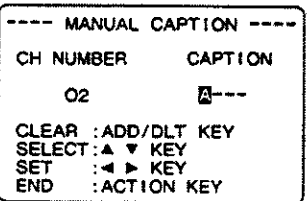

- 1) Press ▲▼ to select.
- 2) Press ► to enter.

- Characters change in the following order.

→ A—B—C—...—Z—BLANK— — — & ←
 → 9—...—2—1—0—/—! ←

- Press ◀ repeatedly to move the cursor to "CH NUMBER." Repeat steps 3 and 4 as desired.

To Make Corrections

Press ▲▼, then ► to select the channel number. Press ▲▼ to change, or ADD/DLT to delete.

5 End setup.



Press ACTION four times.

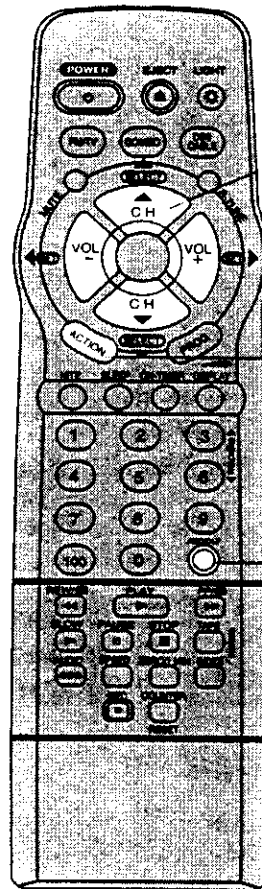

- 2 SELECT/SET
- 3 ▲:CH UP
▼:CH DOWN
- 4 ►:VOL UP
◀:VOL DOWN
- 5 ACTION

ADD/DLT

Advanced Operation

Special VCR Features (continued)

Time Stamp Feature

The Combination VCR writes program data (see example below) about the first 10 seconds of every recording. The information is then displayed the first 10 seconds of playback. To change the data, see "Changing Time Stamp Data" section on next page.

Check list before you begin.

- The clock is set to correct time.
- The record tab is in place.

1  **Display MAIN MENU.**
Press ACTION*.

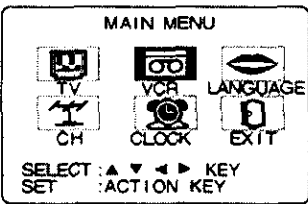
2  **Display SET UP VCR screen.**

1) Press ▲▼◀▶ to select "VCR."
2) Press ACTION to display.

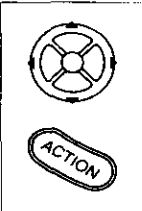

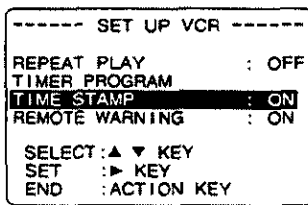
3  **Select TIME STAMP.**

1) Press ▲▼ to select.
2) Press ▶ to set "ON" or "OFF."

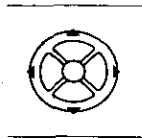

- When "OFF" is selected, the program data is written on the tape, but will not be displayed.

4  **Return to normal screen.**
Press ACTION twice.

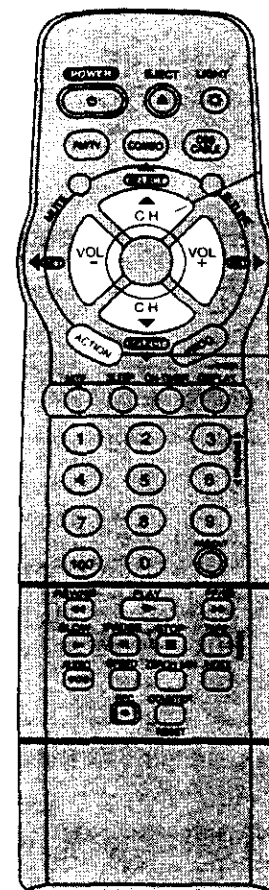

- 2 SELECT/SET
- 3 ▲:CH UP
▼:CH DOWN
▶:VOL UP
◀:VOL DOWN
- 1 ACTION
- 2
- 4

<Time Stamp Example >

Normal/ One
Touch Recording

12/28/1999 TUE
12:00PM
CH 08 ABC

Timer
Recording

12/27/1999 MON
12:00PM - 1:00PM
CH 08 ABC MOVIE
MEMORIAL MOVIE

When Clock is
not set...

CH 08 ABC

★ Important: If the remote control POWER, CH Up/Down, NUMBERED keys, ACTION, PROG, DISPLAY, TAPE POSITION, INDEX, ON-TIMER, R-TUNE, FM/TV, and ADD/DLT button does not work when pressed, press COMBO button on the remote and try the button again.

Changing Time Stamp Data

You may change the time stamp data (Date, Time, Channel, Category, and Notes) as desired.



Display Time Stamp Data.

- 1) Insert cassette with record tab.
- 2) Press PLAY.

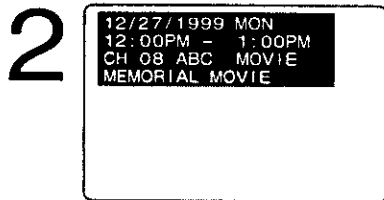

Display TIME STAMP EDIT.



Press PROG while the data is displayed in playback mode.

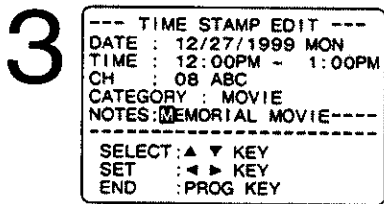

Change Time Stamp Data.

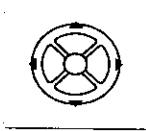

- 1) Press ▲▼ to select.
 - 2) Press ► or ◀ to enter and continue.
- Characters in NOTES will change in the following order.

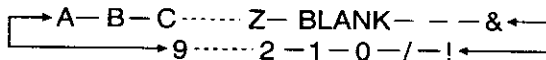

- 3) Repeat 1) and 2) as needed.

To Make Corrections

Press ◀▶ to move to the incorrect entry, then press ▲▼ to make the correction.

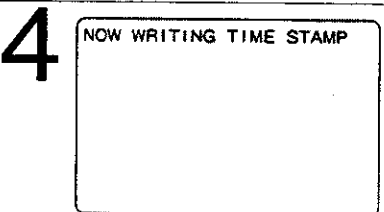

Write the new data.



Press PROG.

- After the data is written, the Combination VCR automatically goes into Stop mode.
- You cannot use POWER or REC button while "NOW WRITING TIME STAMP" is displayed.

Model PV-M2079 unit is shown here.

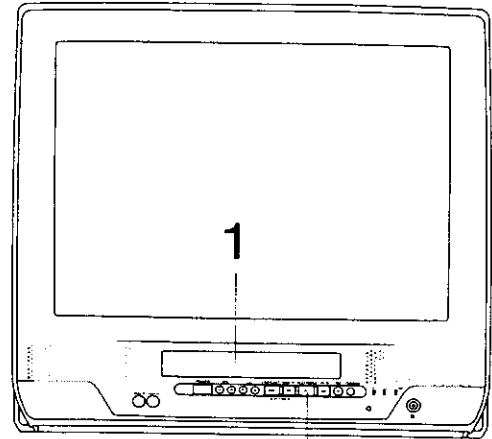

1 PLAY/REPEAT

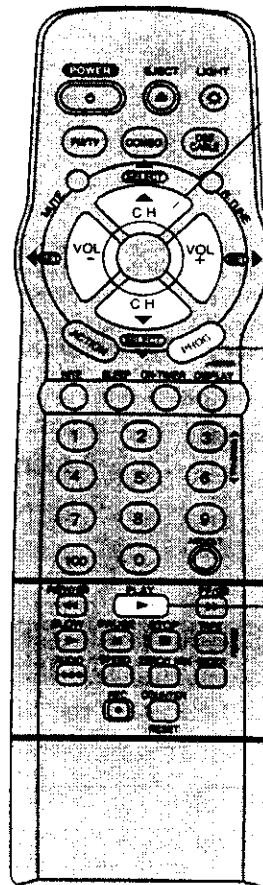

3 SELECT/SET

- ▲:CH UP
- ▼:CH DOWN
- :VOL UP
- ◀:VOL DOWN

2 PROG
4

1 PLAY

Advanced Operation

Special VCR Features (continued)

Weak Signal Display ON/OFF

When "ON" is selected, picture is displayed even when broadcast signal is weak or nonexistent.

1  **Display MAIN MENU.**
Press ACTION*.

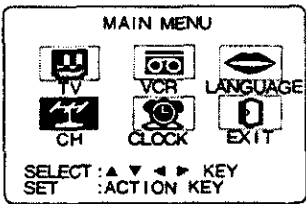
2  **Display SET UP CH screen.**
SELECT: ▲▼◀▶ KEY
SET : ACTION KEY

 1) Press ▲▼◀▶ to select "CH."
2) Press ACTION to display.

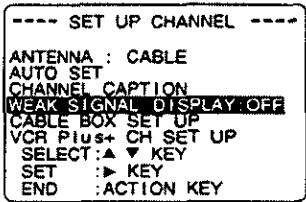

3  **Select WEAK SIGNAL DISPLAY.**
ANTENNA : CABLE
AUTO SET
CHANNEL CAPTION
WEAK SIGNAL DISPLAY: OFF
CABLE BOX SET UP
VCR Plus+ CH SET UP
SELECT: ▲▼ KEY
SET : ▶ KEY
END : ACTION KEY

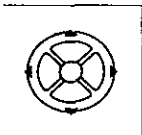
 1) Press ▲▼ to select.
2) Press ▶ to set "ON" or "OFF."

Notes

- "ON" = Picture is displayed regardless of signal condition, and may not always be clearly visible.
- "OFF" = Screen turns solid blue when signal is absent or weak.
- If Combination VCR is connected to equipment which has blue back feature, selecting "ON" will have no effect on the other equipment.

4  **Return to normal screen.**
Press ACTION twice.

Model PV-M2079 unit is shown here.

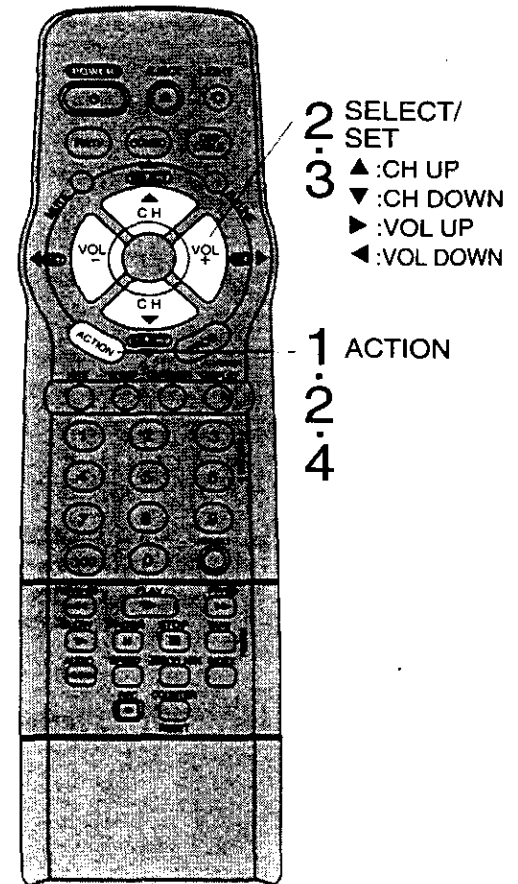
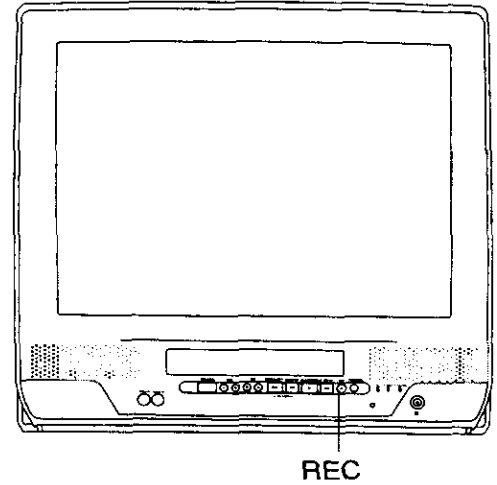

VCR Lock

All operations are prohibited except Timer recording and tape eject. Useful for families with small children.

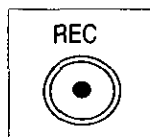
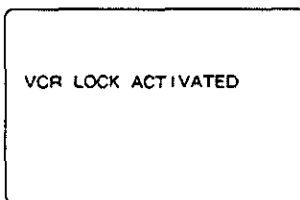

To turn "ON."
In stop mode, hold down REC on the Combination VCR without a cassette for 7 seconds.

To turn "OFF:"
Repeat above with or without a cassette.

- VCR Lock is cancelled automatically after 24 hours if clock is set.

Copying Your Tapes (Dubbing)

★ Important: If the remote control POWER, CH Up/Down, NUMBERED keys, ACTION, PROG, DISPLAY, TAPE POSITION, INDEX, ON-TIMER, R-TUNE, FM/TV, and ADD DLT button does not work when pressed, press COMBO button on the remote and try the button again.

Connections you'll need to make.

Model PV-M2079 unit is shown here.

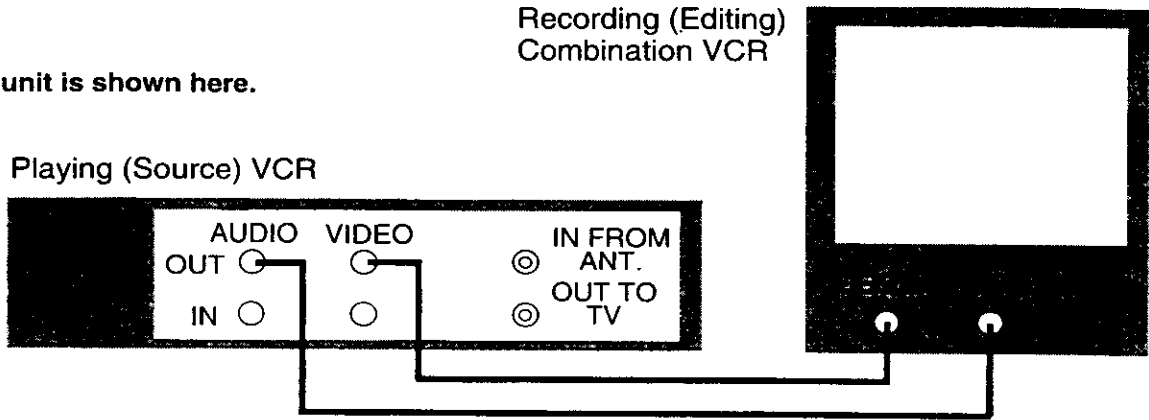

Model PV-M2089 unit is shown here.

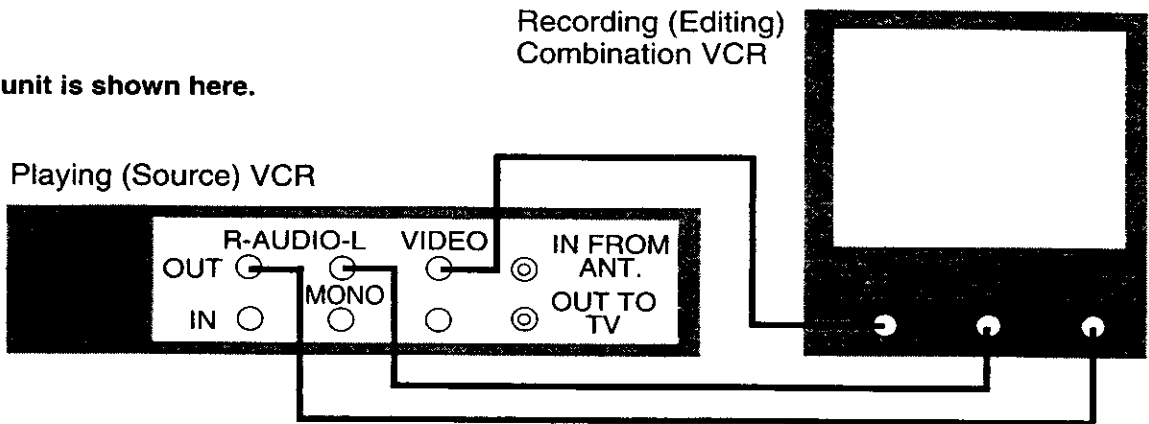

Advanced Operation

Playback (Source) VCR

Recording (Editing) Combination VCR

1  **Insert pre-recorded tape.**

 **Insert blank tape with record tab.**

- Dubbing tapes protected with Copy Guard will have poor quality results.

2 _____ **Select "LINE" mode.**
See "Selecting Input Mode" section on page 11.

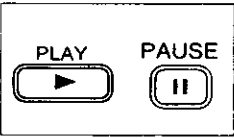
3  **Put in Standby mode.**
Press PLAY then PAUSE at starting point.

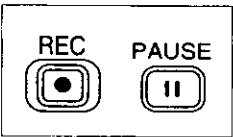
 **Put in Standby mode.**
Press REC, then PAUSE immediately.

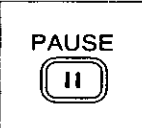
4  **Start dubbing.**
Press PAUSE.

 **Start dubbing.**
Press PAUSE.

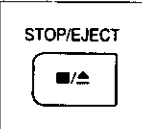
5  **Stop dubbing.**
Press STOP/EJECT.

 **Stop dubbing.**
Press STOP/EJECT.

Caution: Unauthorized exchanging and/or copying of copyrighted recordings may be copyright infringement.

V-Chip Control Feature

V-Chip Control Feature is...

The Combination VCR has built-in V-Chip Control which allows you to block unwanted TV usage based on Motion Picture and TV Parental Guide ratings.

Process of V-Chip Control Feature

Enter Code → Setup → Blocking

Enter Secret Code

A 4 digit code must be entered to view a blocked program or change rating settings.

1



Display MAIN MENU.
Press ACTION*.

2

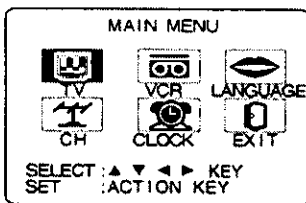

Display SET UP TV screen.

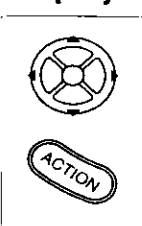

- 1) Press ▲▼◀▶ to select "TV."
- 2) Press ACTION to display.

3

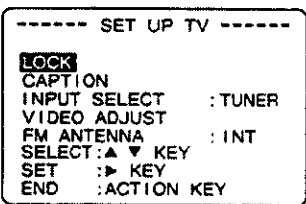

Select LOCK.

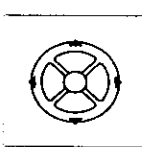

- 1) Press ▲▼ to select.
- 2) Press ▶ to display.

4

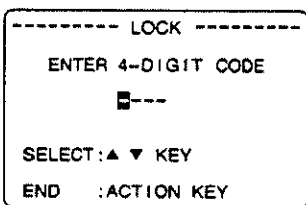

Enter your secret code.

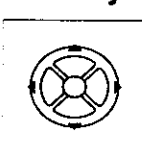

- 1) Press ▲▼ to select a number.
- 2) Press ▶ (or ◀) to set.

- Repeat step 4 until 4-digit is filled.
- Take care that you are not observed entering the secret code.

To Make Corrections

Press ◀▶ to move the cursor and ▲▼ to make the correction.

5

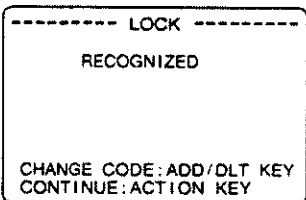

Save 4-DIGIT CODE.

Press ACTION.



6



Display LOCK menu for rating screen.

Press ACTION and go to:
page 35 (MOTION PICT. Ratings),
or page 36 (TV PARENTAL Ratings)

Or,

to exit, press ACTION four times.

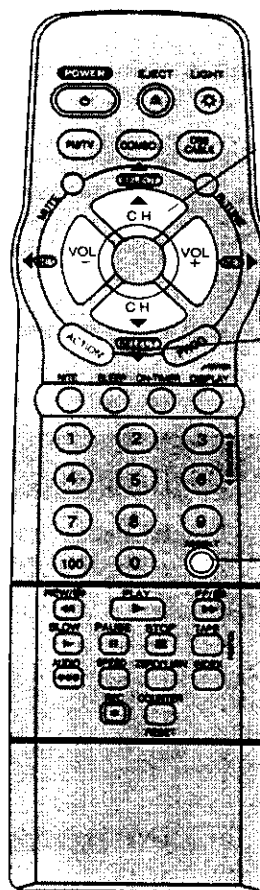

- 2 SELECT/SET
 - 3 ▲:CH UP
 - 4 ▼:CH DOWN
 - 5 ▶:VOL UP
 - 6 ◀:VOL DOWN
- 1 ACTION
- 2 5 6 — ADD/HLT

Change your secret code

- You will need your current code.
- Do steps 1~4. In step 5, press ADD/HLT to clear current code. Repeat steps 4 and 5 to enter new code.

★ Important: If the remote control POWER, CH Up/Down, NUMBERED keys, ACTION, PROG, DISPLAY, TAPE POSITION, INDEX, ON-TIMER, R-TUNE, FM/TV, and ADD/HLT button does not work when pressed, press COMBO button on the remote and try the button again.

Setup MOTION PICT. (PICTURE) Ratings

If LOCK menu is not displayed, do "Enter Secret Code" steps on page 34.

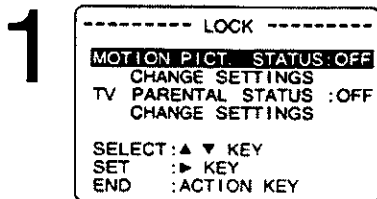

Select MOTION PICT. STATUS.



- 1) Press ▲▼ to select.
- 2) Press ► to set "ON" or "OFF."

If you select MOTION PICT. STATUS:

- "ON" → V-Chip Control is activated.
- "OFF" → V-Chip Control is deactivated.

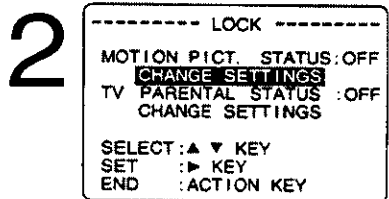

Select CHANGE SETTINGS.



- 1) Press ▲▼ to select.
- 2) Press ► to display.

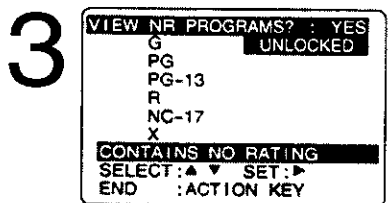

Select VIEW NR PROGRAMS?

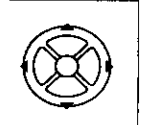

- 1) Press ▲▼ to select.
- 2) Press ► to set "YES" or "NO."

NR (Not Rated) PROGRAMS

Some movies, such as old movies or foreign movies usually have no ratings.

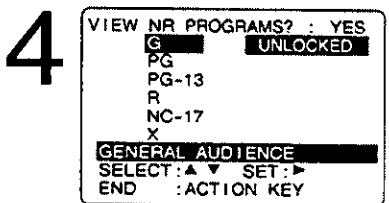

Select ratings to be blocked. (See right.)

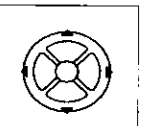

- 1) Press ▲▼ to select.
- 2) Press ► to set.



Redisplay LOCK menu to continue setup.

Press ACTION and go to page 36 (TV PARENTAL Ratings)

Or,

to exit, press ACTION four times.

Process of V-Chip Control Feature

Enter Code → Setup → Blocking

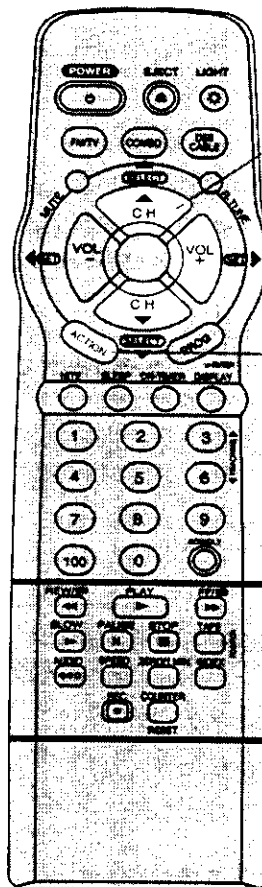

- 1 SELECT/SET
- 2 ▲:CH UP
▼:CH DOWN
- 3 ►:VOL UP
- 4
- 5 ACTION

Advanced Operation

MOTION PICTURE RATINGS

G	GENERAL AUDIENCE: All ages admitted.
PG	PARENTAL GUIDANCE: Some material may not be suitable for children.
PG-13	PARENTS CAUTIONED: Some material may be inappropriate for children under 13.
R	RESTRICTED: Under 17 requires accompanying parent or adult children.
NC-17	OVER AGE 17 ONLY: No one 17 and under admitted.
X	ADULTS ONLY:

V-Chip Control Feature

Setup TV PARENTAL Ratings

Process of V-Chip Control Feature



If LOCK menu is not displayed, do "Enter Secret Code" steps on page 34.

1

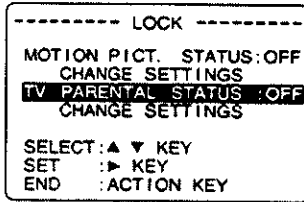

Select TV PARENTAL STATUS.

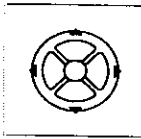

- 1) Press ▲▼ to select.
- 2) Press ▶ to set "ON" or "OFF."

If you select TV PARENTAL STATUS:

- "ON" → V-Chip Control is activated.
- "OFF" → V-Chip Control is deactivated.

2

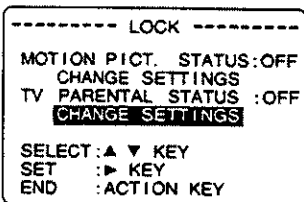

Select CHANGE SETTINGS.

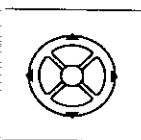

- 1) Press ▲▼ to select.
- 2) Press ▶ to display.

3

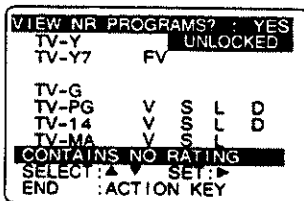

Select VIEW NR PROGRAMS?



- 1) Press ▲▼ to select.
- 2) Press ▶ to set "YES" or "NO."

NR (Not Rated) PROGRAMS

Some TV shows, such as news, sports, weather, bulletins, emergency information usually have no ratings.

4

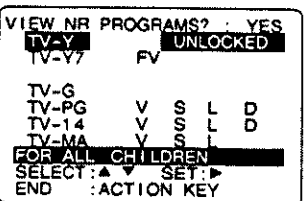

Select ratings to be blocked. (See next page.)

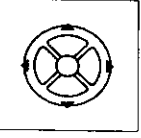

- 1) Repeatedly press ▲▼ to select.
- 2) Press ▶ to set.

- Ratings which are highlighted in GREEN will be blocked, when not highlighted (white letters), these will not be blocked.

Note

You may select from standard TV ratings (chart 1), or customize to a specific content rating (chart 2.)

5



End setup.

Press ACTION four times.

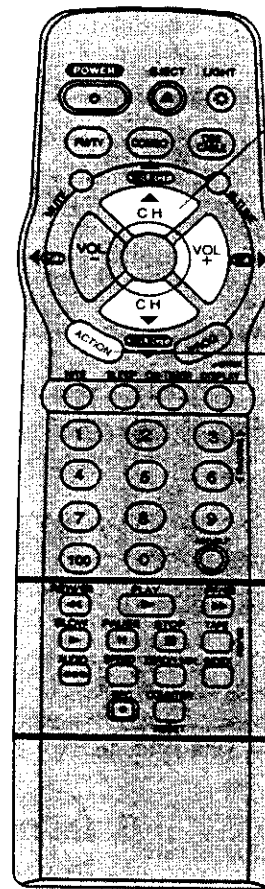

- 1 SELECT/SET
- 2 ▲:CH UP
▼:CH DOWN
- 3 ▶:VOL UP
◀:VOL DOWN
- 4
- 5 ACTION

★ Important: If the remote control POWER, CH Up/Down, NUMBERED keys, ACTION, PROG, DISPLAY, TAPE POSITION, INDEX, ON-TIMER, R-TUNE, FM/TV, and ADD/DLT button does not work when pressed, press COMBO button on the remote and try the button again.

**TV PARENTAL GUIDE RATINGS:
Chart 1**

TV-Y	FOR ALL CHILDREN: Content specifically geared to young viewers ages 2-8.
TV-Y7	FOR AGE 7 AND OLDER: May contain mild physical or comedic violence which may frighten children under 7.
TV-G	GENERAL AUDIENCE: Contains little or no violence, strong language, or sexual dialogue or situations.
TV-PG	PARENTAL GUIDANCE: May contain infrequent coarse language, limited violence, some suggestive sexual dialogue and situations.
TV-14	PARENTS CAUTIONED: May contain sophisticated themes, sexual situations, strong language, and more intense violence.
TV-MA	MATURE AUDIENCE: May contain mature themes, profane language, graphic violence, and sexual situations.

Process of V-Chip Control Feature



Blocking Message

<When V-Chip Control is activated>

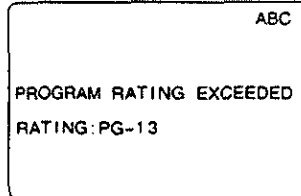

- If V-Chip Control is activated, and a program or movie exceeds the ratings you have set, a message will appear on a black background and sound is muted.

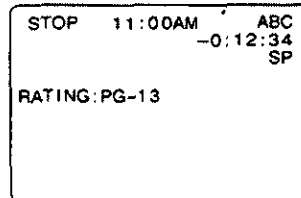

- If DISPLAY is pressed, even when V-Chip control is deactivated, rating is displayed on-screen.

To Continue Viewing a Blocked Program

After entering your 4 digit secret code, go to step 1 on both pages 35 and 36 and select "OFF" to deactivate V-Chip Control.

- The previous MOTION PICT. and TV PARENTAL settings will be restored.

**TV PARENTAL GUIDE RATINGS:
Chart 2**

FV	Fantasy Violence
V	Violence
S	Sexual Situations
L	Adult language
D	Sexual Suggestive Dialog

Advanced Operation

Cable Box Universal Remote Control Feature

The Universal Remote Control Setup

- 1 Find your DSS box or Cable box Brand Code Number from one of the charts on the next page.

2

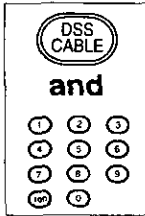

Setup remote.

- 1) Hold down DSS CABLE.
- 2) Press NUMBERED keys to enter code.

• For code 100 or greater, first press the 100 key first, and then remaining digit. E.g., for 102, press 100, then press 0, and then press 2.

3

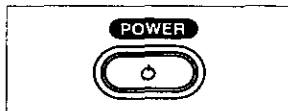

Confirm code entry.

Press POWER* to turn selected unit ON or OFF.

• See below for a list of controllable functions in each mode.

Notes

- Please repeat the Universal Remote Control Setup after replacing remote control batteries.
- The remote control will not operate all DSS receivers or Cable Boxes made by these manufactures listed. If you get no results, your particular brand cannot be controlled.

Using the Universal Remote Control

Once the remote control has been properly setup, you can select COMBO, DSS or CABLE mode depending on which functions you wish to control. (See below.)

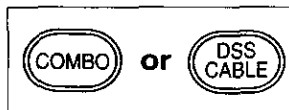

Press **COMBO** or **DSS CABLE** on the remote control to select the desired mode. (The below list shows which buttons are available for each mode.)

Set to COMBO:

- All TV and VCR functions

Set to DSS CABLE:

- Basic VCR functions, e.g. PLAY, REC, etc.

Notes

- In DSS or CABLE mode, it may be necessary to press ENTER after pressing NUMBERED keys for channel selection.
- In DSS or CABLE mode, POWER, CH Up/Down, NUMBERED Keys, ACTION, PROG, DISPLAY, TAPE POSITION, INDEX, ON-TIMER, R-TUNE, FM/TV, and ADD/DLT are not available. Press COMBO to use these functions.
- Depending on your DSS receiver or Cable box brand, some of the functions listed may not be remote controllable.
- Some DSS receiver or Cable box brands require you to turn on the power manually.
- Due to changes in infra-red commands used by manufacturers, some brands have several codes. If your unit does not respond to the first code, please try the next one.

Universal Remote Control is...

The Remote Control maybe set up to control some of the functions.

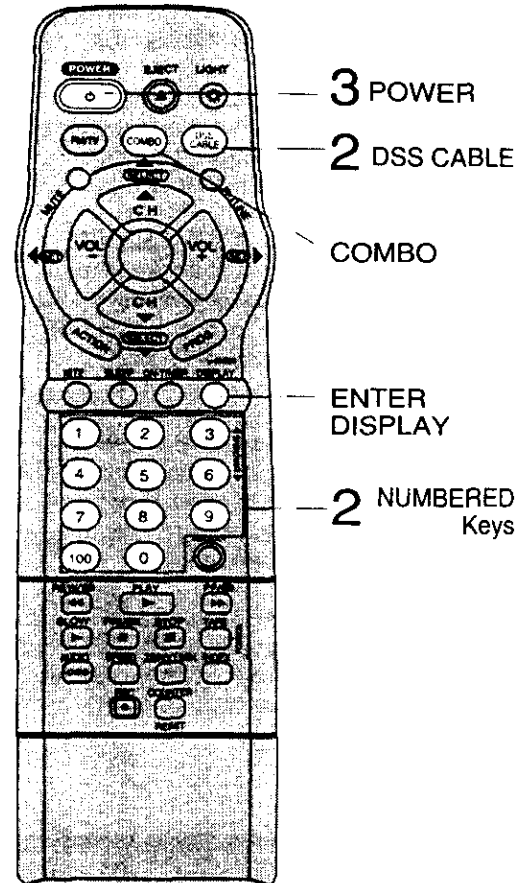

★ Important: If the remote control POWER, CH Up/Down, NUMBERED keys, ACTION, PROG, DISPLAY, TAPE POSITION, INDEX, ON-TIMER, R-TUNE, FM/TV, and ADD/HLT button does not work when pressed, press COMBO button on the remote and try the button again.

Remote Warning ON/OFF

If Universal Remote Control on previous page is used, and this feature is set to "ON," a warning appears whenever an invalid key is pressed in DSS or CABLE mode.



Display MAIN MENU.
Press ACTION.

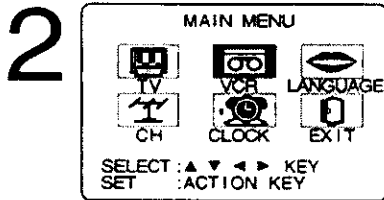

Display SET UP VCR screen.

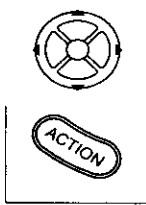

- 1) Press ▲▼◀▶ to select "VCR."
- 2) Press ACTION to display.

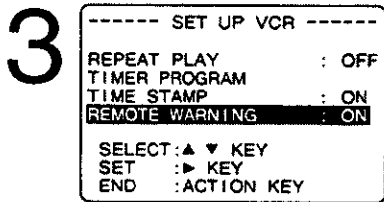

Select REMOTE WARNING.

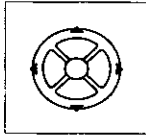

- 1) Press ▲▼ to select.
- 2) Press ▶ to set "ON" or "OFF."

• "OFF" → Remote warning will not appear even if invalid key is pressed.

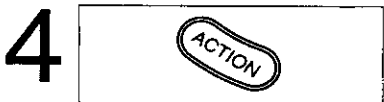

Return to normal screen.
Press ACTION twice.

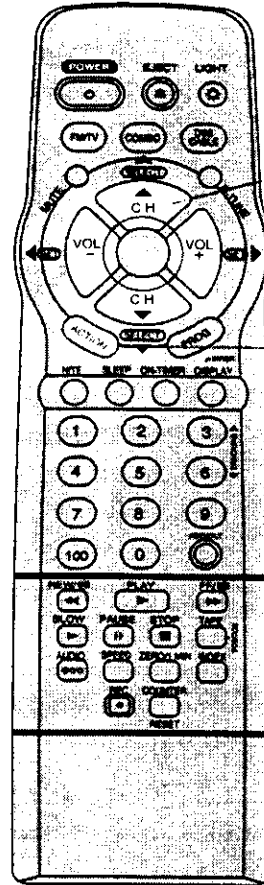

- 2 SELECT/SET
- 3 ▲:CH UP
▼:CH DOWN
▶:VOL UP
◀:VOL DOWN
- 1 ACTION
- 2 4

Advanced Operation

DSS Brand Code Numbers

Toshiba.....	92	Magnavox/ Uniden 2	95	Sony	98, 105
Hitachi/Hughes	93	Panasonic	96		
Magnavox/ Uniden 1	94	RCA	97		

Cable Box Brand Code Numbers

Archer	01, 05, 06, 44, 63, 91, 126	Matsushita	16, 17, 97, 109	Sheritech	27
Cabletenna	01, 44, 63, 91, 126	Movietime	32, 38, 39, 40, 42, 44, 126	Signal	26, 112
Cableview..	04, 30, 42, 44, 52, 63, 124, 126	NEC	32, 38, 40	SL Marx ..	06, 32, 40, 42, 43, 44, 52, 63, 126
Century	44, 51, 59, 75	NOVAVISION	08, 09, 53, 61	Sprucer	16, 17, 97, 109
Citizen....	04, 30, 42, 44, 52, 63, 124, 126	NSC	32, 38, 40	Standard Components ..	32, 39, 42, 44, 126
Curtis	08, 09, 53, 61, 87	Oak	11, 46, 129	Stargate	
Diamond	01, 44, 63, 91, 126	Oak Sigma.....	11, 46, 129	04, 06, 30, 32, 40, 42, 44, 52, 63, 124, 126	
Drake	67	Panasonic	16, 17, 97, 109	Sylvania	19
Eagle	13, 20, 22, 26, 40, 58, 62, 107	Philips	07, 13, 20, 23, 24, 50, 128, 129	Teknika	74
Eastern	28, 130	Pioneer	05, 06	Telecaption	77, 127
GC Brand ..	04, 30, 42, 44, 52, 63, 124, 126	Pulsar	04, 30, 42, 44, 52, 63, 124, 126	Television	06, 32, 40, 42
Gemini.....	04, 124	Quest	05, 06	Texscan	18, 19
General Electric.....	01, 57	Radio Shack	44, 51, 59, 75	Tocom	01, 33, 34, 42, 66, 91
General Instruments ..	01, 02, 03, 04, 34, 55, 65, 67, 68, 83, 91, 115, 117, 118, 124	RCA	16, 17, 97, 109	Toshiba	36
Hamin.....	14, 15, 28, 41, 102, 103, 104, 108, 130	Realistic	44, 51, 59, 75, 126	Uniden Satellite	65
Hitachi	31	Recoton	44, 51, 59, 75, 126	Unika	01, 44, 63, 91, 126
Jasco	04, 124	Regal ..	14, 15, 28, 41, 102, 103, 104, 108, 130	Universal	42, 43, 44, 52, 63, 126
Jerrold.....	01, 02, 03, 04, 34, 55, 65, 67, 68, 83, 91, 115, 117, 118, 124	Regency	28, 130	Videoway	07, 23, 50, 129
Macom.....	31	Rembran	01, 32, 39, 42, 44, 63, 126	Vid Tech	64
Magnavox	26, 112	Salora	68	Vidter	64
		Samsung	05, 06, 32, 40, 42	Viewstar ..	13, 20, 22, 26, 40, 58, 62, 107
		Scientific Atlanta	08, 09, 53, 61, 87	Zenith	07, 23, 50, 129

Picture Adjustment

1



Display MAIN MENU.
Press ACTION*,

2

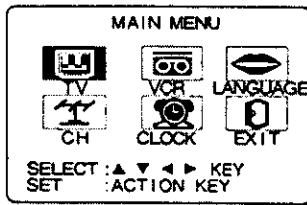

Display SET UP TV screen.

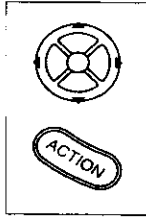

- 1) Press ▲▼◀▶ to select "TV."
- 2) Press ACTION to display.

3

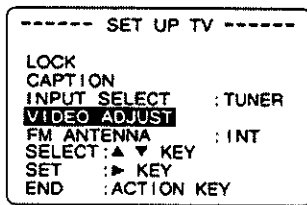

Display VIDEO ADJUST screen.

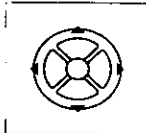

- 1) Press ▲▼ to select.
- 2) Press ▶ to display.

<For Model PV-M2079 only>

4

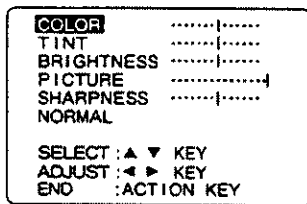

Adjust desired item.

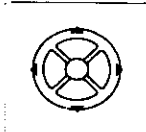

- 1) Press ▲▼ to select on item. (See below right.)
- 2) Press ◀▶ to adjust.

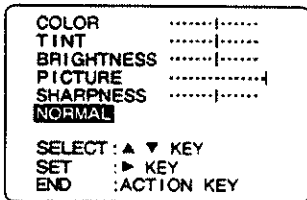

To Reset Picture Controls

Press ▲▼ and ▶ to select and set "NORMAL."
All controls return to their factory settings.

5



End setup.
Press ACTION three times to exit.

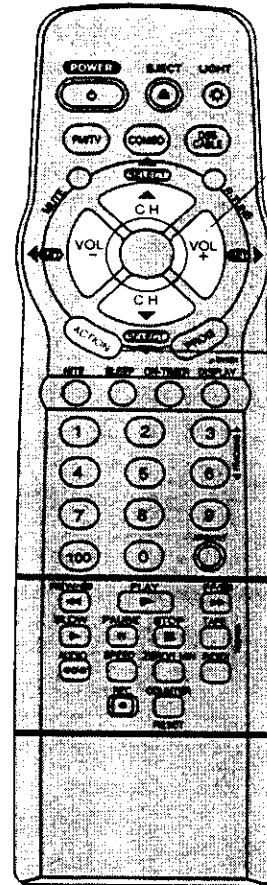

- 2 SELECT/SET
- 3 ▲:CH UP
▼:CH DOWN
- 4 ▶:VOL UP
◀:VOL DOWN
- 1 ACTION
- 2
- 5

Picture Adjustment

COLOR Control
Adjust color intensity.

TINT Control
Adjust for natural flesh tones.

BRIGHTNESS Control
Adjust picture brightness.

PICTURE Control
Adjust picture intensity by adjusting both contrast and color level in the proper balance.

SHARPNESS Control
Adjust picture sharpness.

Audio Features

★ Important: If the remote control POWER, CH Up/Down, NUMBERED keys, ACTION, PROG, DISPLAY, TAPE POSITION, INDEX, ON-TIMER, R-TUNE, FM/TV, and ADD/DLT button does not work when pressed, press COMBO button on the remote and try the button again.

Speaker ON/OFF System

Allows you to turn off the speaker of the Combination VCR when it is connected to external audio equipment.

1  **Display MAIN MENU.**
Press ACTION.

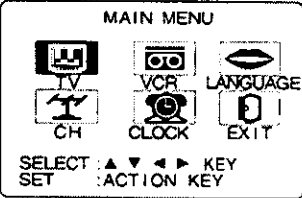
2  **Display SET UP TV screen.**
1) Press ▲▼◀▶ to select "TV."
2) Press ACTION to display.

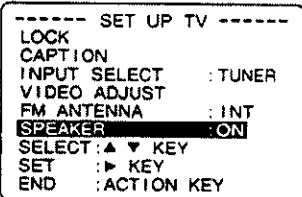
3  **Select SPEAKER.**
1) Press ▲▼ to select.
2) Press ▶ to set "ON" or "OFF."

<For Model PV-M2089 only>

4  **End setup.**
Press ACTION twice.
• In SPEAKER OFF condition, the MUTE button and VOL + - do not function.

Select Audio Mode for Playback

Select the type of sound track you desire for playback.

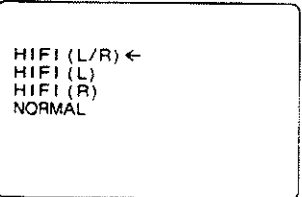
1  **Select desired mode.**
Press AUDIO repeatedly (each press within 5 seconds.)

<For Model PV-M2089 only>

• Select "HIFI(L/R)", "HIFI(L)" or "HIFI(R)" to listen to stereo recordings in stereo sound. Select "NORMAL" for monaural sound.

2 **Playback the tape.**
See the "Playback a Tape" section on page 10.

<For Model PV-M2089 only>

With the proper audio mode setting, your Combination VCR can:

- record and playback an MTS stereo broadcast (main language) in stereo Hi-Fi. Stereo sound is recorded on the left and right audio tracks and on the video portion of a tape.
- record and playback a monaural broadcast (main language) or an SAP (Sound Audio Program, usually in a second language) on the Hi-Fi tracks for better quality monaural sound.
- playback non-Hi-Fi tapes in monaural.

Select Audio Mode for Recording

Select the type of broadcast and sound track you wish to record.

1 **Do the operation of "Select Audio Mode for TV Viewing" section on page 9.**

- Your recording is always performed according to the audio mode you selected in the "Select Audio Mode for TV Viewing" section on page 9.

2 **Do a recording.**
See the "Record On a Tape" section on page 11.

Notes

- When purchasing or renting prerecorded tapes, remember that only those recorded in Hi-Fi stereo will play back with true stereo sound. Standard stereo tapes will playback with monaural sound.
- In order to listen to Hi-Fi stereo playback, the Combination VCR AUDIO (L/R) jacks must be connected to a stereo amp and speakers.
- There may be a difference in audio level between Hi-Fi and normal audio playback.

Equipped with **dbx**®-TV Noise Reduction for true MTS reproduction.

dbx®-TV Noise Reduction is required for good stereo separation and audio fidelity. **dbx**® is a registered trademark, and is licensed by **dbx**® Technology Licensing.

Reset Language, Channels, Clock

Language

1

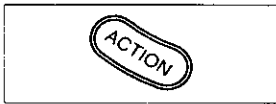

Display MAIN MENU.
Press ACTION*.

2

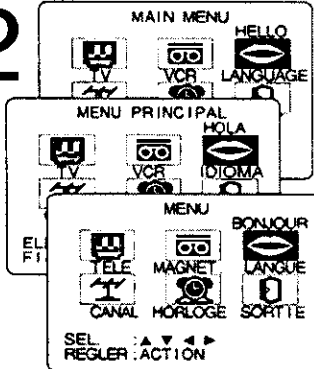

Select the language selection icon.
1) Press ▲▼◀▶ to select.
English:LANGUAGE
Spanish:IDIOMA
French:LANGUE
2) Press ACTION repeatedly to set.

3

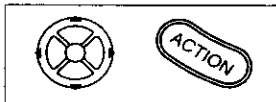

End setup.
1) Press ▲▼◀▶ to select "EXIT."
2) Press ACTION to exit.

Channels

1

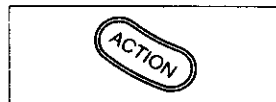

Display MAIN MENU.
Press ACTION.

2

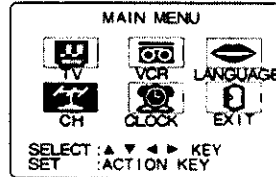

Display SET UP CH screen.
1) Press ▲▼◀▶ to select "CH."
2) Press ACTION to display.

3

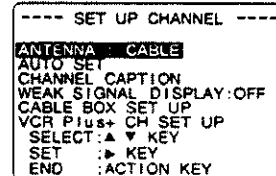

Select ANTENNA.
1) Press ▲▼ to select.
2) Press ▶ to select your antenna system ("TV" or "CABLE").

4

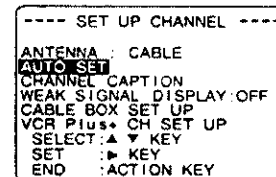

Select AUTO SET.
1) Press ▲▼ to select.
2) Press ▶ to start.

5

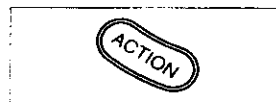

End setup.
Press ACTION twice.

Clock

1

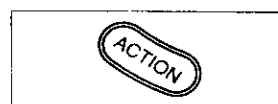

Display MAIN MENU.
Press ACTION.

2

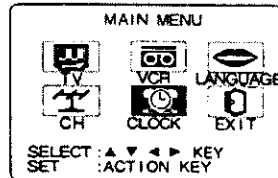

Display SET CLOCK screen.
1) Press ▲▼◀▶ to select "CLOCK."
2) Press ACTION.

3

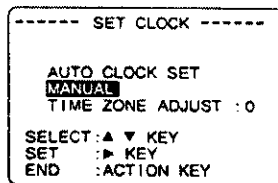

Display MANUAL screen.
1) Press ▲▼ to select "MANUAL."
2) Press ▶ to set.

• For Auto Clock Set, select "AUTO CLOCK SET" then press ▶ to set and CH ▲ to start.

4

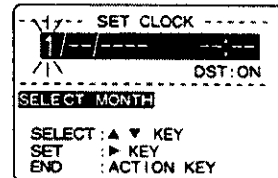

Set the clock manually.
1) Press ▲▼ to select the month.
2) Press ▶ to set.

• Likewise set date, year, time, and DST. (Daylight Saving Time.)

To Make Corrections, repeatedly press ◀▶ to move to error, then correct.

5

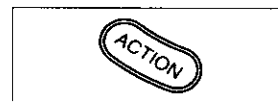

End setup.
Press ACTION twice to start the clock and exit this mode.

Add or Delete a Channel

To add channel:
Select channel with NUMBERED keys and press ADD/DLT.

CHANNEL 08 ADDED

To delete channel:
Select channel with CH▲▼ or NUMBERED keys and press ADD/DLT.

CHANNEL 08 DELETED

On-Screen Displays (OSD)

* Important: If the remote control POWER, CH Up/Down, ACTION, PROG, DISPLAY, TAPE POSITION, INDEX, ON-TIMER, R-TUNE, FM/TV, and ADD/HLT button does not work when pressed, press COMBO button on the remote and try the button again.

VCR Status & Clock Display



To display or remove the overlay.
Press DISPLAY.

Receivable Broadcast Types
(See page 9.)

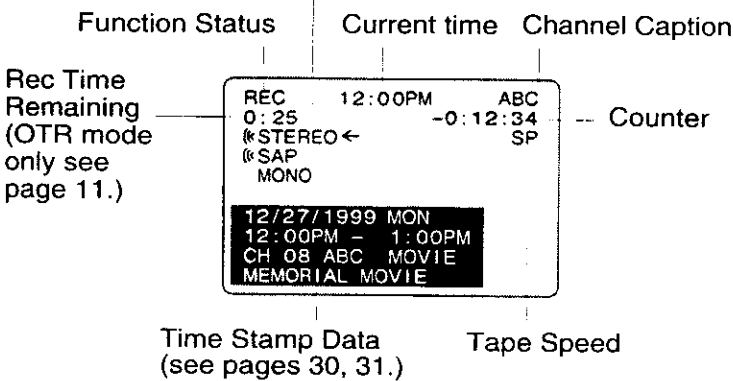

Channel & Function Display

When a function button is pressed (PLAY, FF, etc.) or you change channels, the Combination VCR mode or channel number will be displayed.
(Some station names may also appear if Channel Caption is set. See pages 28, 29.)

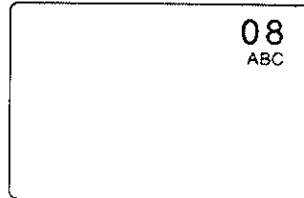

Blue Screen Display

Whenever a blank section of a tape comes up in Play mode, or when the selected channel has no broadcast signal with the "Weak Signal Display ON/OFF" (page 32) set to "OFF", the TV screen will turn solid blue.

Warning and Instruction Displays

These displays will alert you of a missed operation or provide further instructions.

OSD	Caution	Pg	OSD	Caution	Pg
NO CH FOUND PLEASE CHECK ANTENNA CABLE CONNECTION THEN PUSH CH UP KEY AGAIN	If no active channels are found for CHANNEL MEMORY...	5	NO CASSETTE PLEASE INSERT A CASSETTE	If you press PLAY, FF, REW, or REC on the remote control or the Combination VCR without a cassette inserted...	10 11
PLEASE SET CLOCK BEFORE PROGRAMMING	If you attempt to set or review a Timer Recording or set the On-Timer and the Clock is not set...	6 7 42	REMOTE CONTROL IS SET TO DSS/CABLE MODE USE COMBO : COMBO KEY	If you press POWER, ACTION, or PROG on the remote while in DSS or CABLE mode...	38 39
CHECK CASSETTE RECORD TAB	If you press REC on the remote control or the Combination VCR, and a cassette is inserted with no record tab...	4 11	VIDEO HEADS MAY NEED CLEANING PLEASE INSERT HEAD CLEANING CASSETTE OR REFER TO MANUAL END: PLAY KEY	If head cleaning becomes necessary while playing back a tape...	43
TO CANCEL TIMER REC HOLD DOWN STOP KEY FOR APPROX 3 SEC	If you press STOP during a Timer Recording...	13	VCR LOCK ACTIVATED	If you press a function button other than STOP/EJECT or POWER while the Combination VCR is in VCR Lock mode...	32

For Your Information

Unit Information

Reset all Combination VCR Memory Functions

Use when moving Combination VCR to new location, or if a mistake was made in the One Time Setup section.

- Make sure a tape is not inserted in the Combination VCR.

Model PV-M2079 unit is shown here.

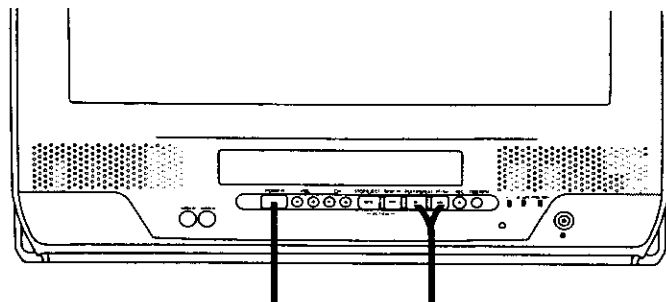

- 1 Turn the Combination VCR Power on.
- 2 Press and hold both the PLAY and FF on the Combination VCR for more than 5 seconds.
 - The power will shut off.

- 3 Do "One Time Setup" Steps on page 6.

DST (Daylight Saving Time)

Combination VCR auto adjusts clock for DST (Daylight Saving Time.)

Spring (First Sunday in April)

DST:ON → Sets clock ahead one hour.

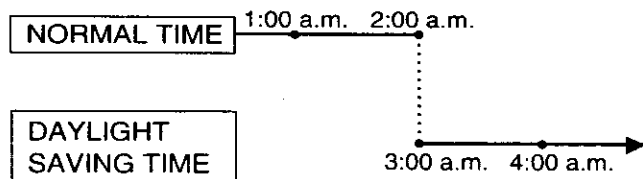

Autumn (Last Sunday in October)

DST:ON → Turns clock back one hour.

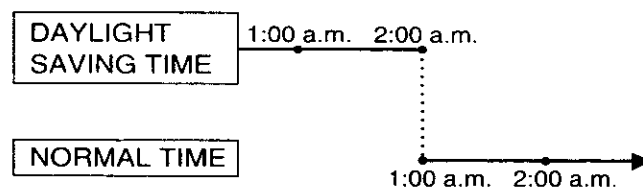

- If your area does not observe Daylight Saving Time, select DST: OFF.
- Keep these time changes in mind when programming the Combination VCR for timer recordings.

Head Cleaning

Playing older or damaged tapes may eventually cause video heads to become clogged.

Head Clog Sensor

During playback this screen appears if clogging is detected. To remove screen, press PLAY on the remote or Combination VCR.

- Use "dry" type head cleaning cassette only. (Part No. NV-TCL30PT is recommended.)

- Follow cleaning tape carefully. Excessive use of tape can shorten head life.

- If head clog symptoms persist, contact your nearest Factory Service Center or authorized Service Center. (See page 46.)

VIDEO HEADS MAY
NEED CLEANING
PLEASE INSERT HEAD
CLEANING CASSETTE
OR REFER TO MANUAL

END:PLAY KEY

Specifications

Display

Picture Tube: 20 inch measured diagonal
90° deflection Picture Tube

VCR

Video Recording System: 4 rotary heads helical
scanning system
Audio Track: 1 track (NORMAL)
2 channel (Hi-Fi Audio Sound)
(PV-M2089)

Tuner:

Broadcast Channels: VHF 2~13, UHF 14~69
CABLE Channels: Midband A through I (14~22)
Superband J through W
(23~36)
Hyperband AA~EEE (37~64)
Lowband A-5~A-1 (95~99)
Special CABLE channel 5A
(01)
Ultraband 65~94, 100~125

FM Radio

Band range: 87.5~108.1 MHz

General

Power Source: 120V AC, 60 Hz
Power Consumption: Approx. 110 watts (Power on)
Approx. 4.5 watts (Power off)
Television System: EIA Standard NTSC color
Speaker: 2 pieces
Operating Temperature: 41°F~104°F (5°C~40°C)
Operating Humidity: 10%~75%
Weight: 50.6 lbs. (23 Kg)
Dimensions: 20-5/16" (W) X 19-7/8" (H) X
18-11/16" (D)
515 (W) X 505 (H) X 474 (D)
mm

Note: Designs and specifications are subject to change without notice.

Before Requesting Service

Check the following points once again if you are having trouble with your Combination VCR.

Power	Correction
No power...	<ul style="list-style-type: none"> • Completely insert Power Plug into an AC outlet. • Set POWER button to ON.
Monitor	Correction
No picture or sound...	<ul style="list-style-type: none"> • Make sure your antenna system (TV or CABLE), is correctly set. (P. 5) • Check that power plug is completely plugged into an AC outlet. • Check that POWER button is set to on.
Poor picture with normal sound...	<ul style="list-style-type: none"> • Adjust BRIGHTNESS, SHARPNESS, and PICTURE controls in the SET UP TV menu. (P.40)
Poor sound with normal picture...	<ul style="list-style-type: none"> • Adjust VOLUME control. (P.8)
Poor TV reception...	<ul style="list-style-type: none"> • Adjust SHARPNESS and PICTURE controls in the SET UP TV menu. (P.40)
No color or poor color...	<ul style="list-style-type: none"> • Adjust TINT and COLOR controls in the SET UP TV menu. (P.40)
Ghost (multiple) images...	<ul style="list-style-type: none"> • Install a directional antenna.
TV programs cannot be watched...	<ul style="list-style-type: none"> • Make sure that the channel being received is in the Combination VCR's memory. (P. 42)
Channel cannot be selected...	<ul style="list-style-type: none"> • The design of this unit is such that only the channel being recorded can be viewed.
VCR	Correction
TV program cannot be recorded...	<ul style="list-style-type: none"> • Make sure your antenna system (TV or CABLE), is correctly set. (P. 5) • Make sure cassette record tab is intact. (P. 4)
Timer recording cannot be performed...	<ul style="list-style-type: none"> • Check clock is set to current time and date. • Make sure DSS/CABLE box (if used) is left on and tuned to channel to be recorded. • Set recording Start/Stop time correctly. (P.12-13) • Timer recording may not be performed or continued if a power interruption of more than 1 minute occurs before or during a Timer Recording, after power is restored.
No playback picture, or the playback picture is noisy or contains streaks...	<ul style="list-style-type: none"> • Adjust TRACKING control in either direction. (P.10) • Try Head Cleaning. (P.44)
VCR cannot be controlled...	<ul style="list-style-type: none"> • Make sure VCR LOCK is set to off. (P. 32) • Make sure unit is not in a Timer Record operation.
Remote Control	Correction
Combination VCR cannot be controlled...	<ul style="list-style-type: none"> • Aim Remote directly at the remote sensor on the Combination VCR. (P. 51) • Avoid any object blocking signal path. • Inspect the remote batteries. (P. 4) • Make sure VCR LOCK is set to off. (P. 32) • Exposing Combination VCR remote sensor to direct fluorescent or outdoor light may cause signal interference.
ACTION , PROG, ON-TIMER and FM/TV buttons cannot be used...	<ul style="list-style-type: none"> • Press COMBO button for COMBO mode. (P. 38) • Check Batteries.
Miscellaneous	Correction
Video cassette cannot be inserted...	<ul style="list-style-type: none"> • Insert the cassette window side up; record tab facing you.
Video cassette cannot be removed...	<ul style="list-style-type: none"> • Completely insert Power Plug into an AC outlet.
Eject does not function or insertion cannot be done...	<ul style="list-style-type: none"> • Turn the POWER off and then on, and try ejecting or inserting the tape again.
Video cassette ejects when a recording is started, or the power is turned off for timer recording...	<ul style="list-style-type: none"> • Make sure cassette record tab is intact. (P. 4)
In stop mode, the VCR motor (CYLINDER) continues to rotate...	<ul style="list-style-type: none"> • To enable Quick Play mechanism, the VCR cylinder will rotate for about 5 minutes. This reduces response time from Stop to Play mode and from Play to Rewind Search mode.
VCR cannot be controlled...	<ul style="list-style-type: none"> • Make sure VCR LOCK is set to off. (P. 32)

If you cannot resolve the problem, please call the Customer Satisfaction Center for product assistance at 201-348-9090.

To locate an authorized servicenter call toll free 1-800-211-PANA(7262.)

Service Center List

For Product Information, Operating Assistance, Literature Request, Dealer Locations, and all Customer Service inquiries please contact:
1-800-211-PANA (7262), Monday-Friday 9 am-9 pm Saturday-Sunday 9 am-7 pm, EST.

Web Site: <http://www.panasonic.com>
You can purchase parts, accessories or locate your nearest servicer by visiting our Web Site.

Accessory Purchases:

1-800-332-5368 (Customer Orders Only)
Panasonic Services Company 20421 84th Avenue South, Kent, WA 98032
(6 am to 5 pm Monday-Friday; 6 am to 10:30 am Saturday; PST)
(Visa, MasterCard, Discover Card, American Express, Check)

Factory Servicenters Locations

CALIFORNIA

6550 Katella Avenue
Cypress, CA 90630

800 Dubuque Avenue
S. San Francisco,
CA 94080

20201 Sherman Way
Suite 102
Canoga Park, CA
91306

3878 Ruffin Road
Suite A
San Diego, CA 92123

COLORADO

1640 South Abilene
Street
Suite D
Aurora, CO 80012

FLORIDA

3700 North 29th Avenue
Suite 102
Hollywood, FL 33020

GEORGIA

8655 Roswell Road
Suite 100
Atlanta, GA 30350

ILLINOIS

9060 Golf Road
Niles, IL 60714

1703 North Randall
Road Elgin, IL 60123
(Pick-up/Drop-off only)

MARYLAND

62 Mountain Road
Glen Burnie, MD 21061

MASSACHUSETTS

60 Glacier Drive,
Suite G
Westwood, MA 02090

MICHIGAN

37048 Van Dyke
Avenue
Sterling Heights,
MI 48312

MINNESOTA

7850-12th Avenue South
Airport Business Center
Bloomington, MN 55425

OHIO

2236 Waycross Road
Civic Center Plaza
Forest Park, OH 45240

PENNSYLVANIA

2221 Cabot Blvd West
Suite B
Langhorne, PA 19047

Chartiers Valley
Shopping Center
1025 Washington Pike
Bridgeville, PA 15017

TENNESSEE

3800 Ezell Road Suite
806
Nashville, TN 37211

TEXAS

7482 Harwin Drive
Houston, TX 77036

13615 Welch Road
Suite 101
Farmers Branch,
TX 75244

WASHINGTON

20425-84th Avenue
South Kent, WA 98032

HAWAII

99-859 Iwaiwa Street
Aiea, Hawaii 96701
Phone (808) 488-1996
Fax (808) 486-4369

Service in Puerto Rico

Matsushita Electric of Puerto Rico, Inc. Panasonic Sales Company/Factory Servicer:
Ave. 65 de Infanteria, Km. 9.5, San Gabriel Industrial Park, Carolina, Puerto Rico 00985
Phone (787) 750-4300 Fax (787) 768-2910

As of April '98

Location of Controls

Remote Control Buttons

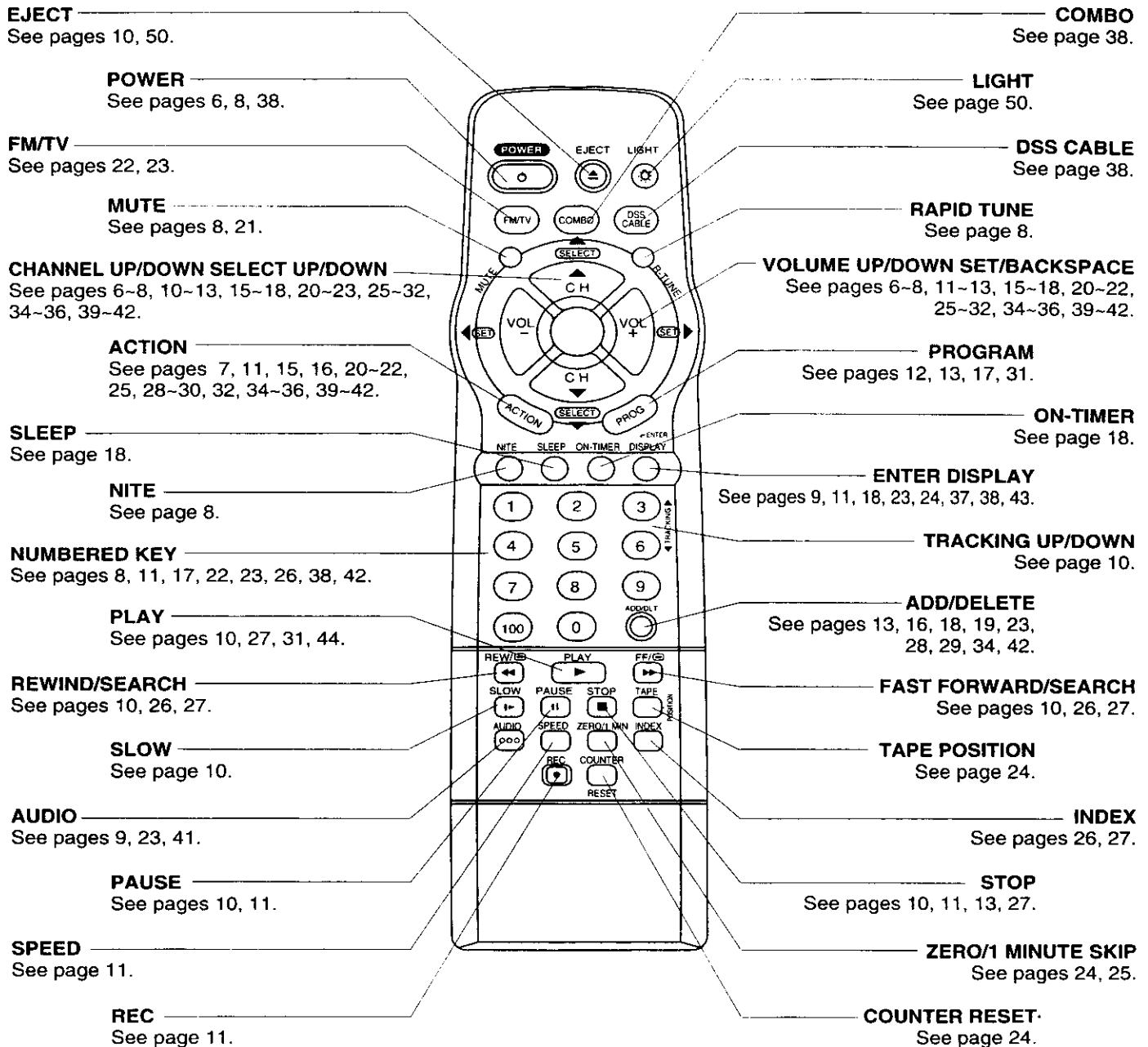

Light Tower™ Universal Remote Control

LIGHT button:

When the LIGHT button is pressed, the buttons which can be activated in the selected mode will light and the selected mode button (COMBO or DSS CABLE) will flash for 5 seconds. If no buttons are pressed within 5 seconds, the light will turn off in order to conserve battery power. Also, while holding down the buttons, the selected mode button will flash so you will be able to see, in the dark, which mode has been selected.

EJECT button:

When EJECT is pressed, the tape is ejected from Cassette Compartment. If EJECT is pressed during recording, the Combination VCR will not respond to the command.

Front View of the Combination VCR and Indicators on the Front Panel

Model PV-M2079 unit is shown here.

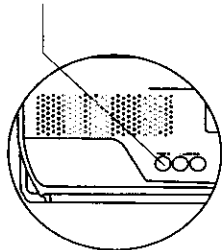
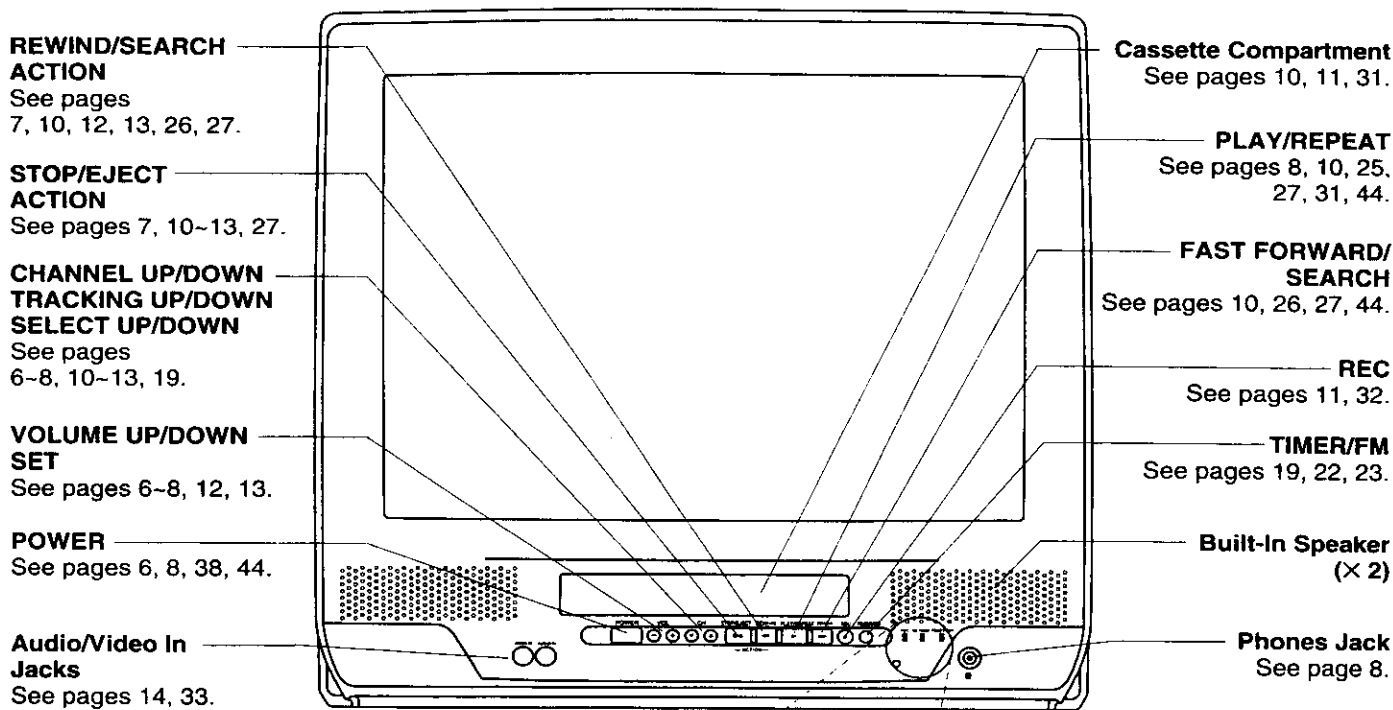

<For Model PV-M2089 only>

REC Indicator
Lights during recording. In Rec Pause or OTR Pause mode, the indicator flashes. See page 11.

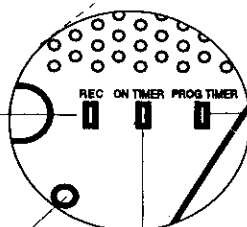

PROG TIMER Indicator
Lights when the Combination VCR is set for Timer Recording. It flashes when a Timer Recording has been set with no tape inserted, the clock is not set, or the tape is in motion. See pages 11, 13, 17.

Remote Sensor

ON TIMER Indicator
Lights when the On Timer is set. See page 18.

Rear View of the Combination VCR

Model PV-M2089 unit is shown here.

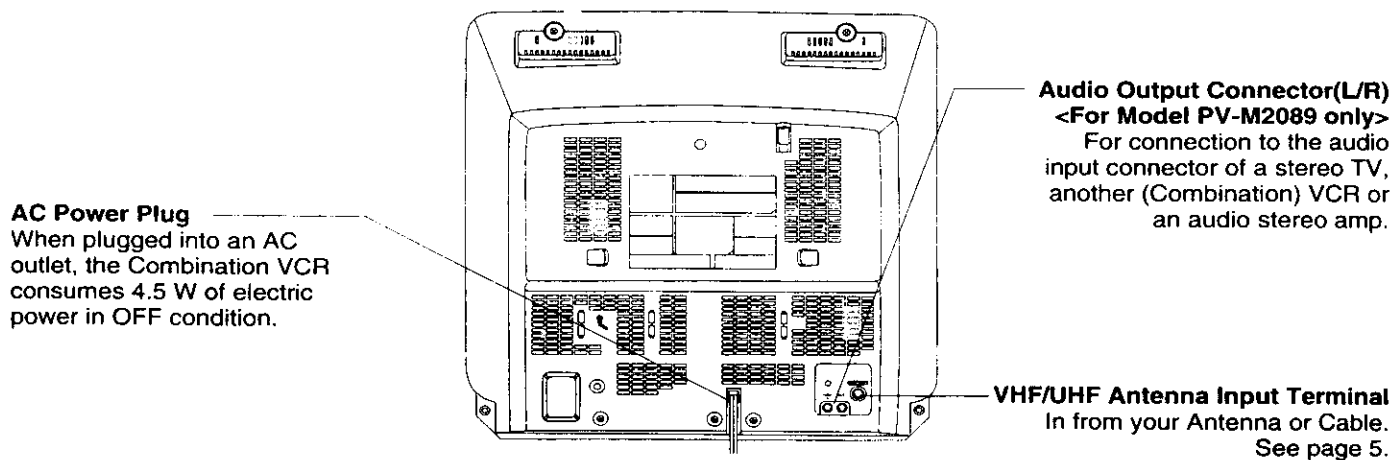

For Your Information

Warranty

Panasonic Consumer Electronics Company,
Division of Matsushita Electric Corporation of America,
One Panasonic Way
Secaucus, New Jersey 07094

Panasonic Sales Company,
Division of Matsushita Electric of Puerto Rico, Inc.
AVE. 65 de Infanteria, Km. 9.5 San Gabriel
Industrial Park Carolina, Puerto Rico 00985

Panasonic Video Products Limited Warranty

Panasonic Consumer Electronics Company or Panasonic Sales Company (collectively referred to as "the Warrantor") will repair this product with new or refurbished parts, free of charge, in the USA or Puerto Rico, in the event of a defect in materials or workmanship as follows (all time periods commence from the date of the original purchase):

<u>PRODUCT</u>	<u>PARTS</u>	<u>LABOR</u>
CAMCORDER	ONE (1) YEAR, EXCEPT CCD IMAGE SENSOR CCD IMAGE SENSOR - SIX(6)MONTHS	NINETY (90) DAYS NINETY (90) DAYS
VCR	ONE (1) YEAR	NINETY (90) DAYS
AV MIXER	ONE (1) YEAR	NINETY (90) DAYS
MONITOR-VCR	ONE (1) YEAR, EXCEPT CRT CRT - TWO (2) YEARS	NINETY (90) DAYS CRT - NINETY (90) DAYS CUSTOMER PAYS ALL LABOR CHARGES AFTER 90 DAYS

Monitor-VCR In-home or carry-in Service: 22" (diagonal) CRT / LCD and Larger Monitor-VCR Carry-in Service: 21" (diagonal) CRT / LCD and smaller

Batteries (if included) - New rechargeable batteries in exchange for defective rechargeable batteries for ten (10) days. Non-rechargeable batteries are not warranted.

Tape (if included) - New video cassette tape in exchange for a defective video cassette tape for five (5) days.

In-home, carry-in or mail-in service, as applicable, in the USA can be obtained during the warranty period by contacting a Panasonic Services Company (PASC) Factory Servicenter listed in the Service Directory. Or call toll free 1-800-211-PANA(7262), to locate an authorized PASC Servicenter. Carry-in or mail-in service in Puerto Rico can be obtained during the warranty period by calling the Panasonic Sales Company telephone number listed in the Servicenter Directory.

This warranty is extended only to the original purchaser. A purchase receipt or other proof of the date of the original purchase is required before warranty service is rendered.

This warranty only covers failures due to defects in materials and workmanship which occur during normal use and does not cover normal maintenance, including, but not limited to, video and audio head cleaning. The warranty does not cover damage which occurs in shipment, or failures which are caused by products not supplied by the warrantor, or failures which result from accident, misuse, abuse, neglect, mishandling, misapplication, alteration, modification, faulty installation, set-up adjustments, improper antenna, inadequate signal pickup, maladjustment of consumer controls, improper operation, power line surge, improper voltage supply, lightning damage, commercial use such as hotel, office, restaurant, or other business or rental use of the product, or service by anyone other than a PASC Factory Servicenter or a PASC authorized Servicenter, or damage that is attributable to acts of God.

LIMITS AND EXCLUSIONS

There are no express warranties except as listed above.

THE WARRANTOR SHALL NOT BE LIABLE FOR INCIDENTAL OR CONSEQUENTIAL DAMAGES (INCLUDING, WITHOUT LIMITATION, DAMAGE TO TAPES) RESULTING FROM THE USE OF THIS PRODUCTS, OR ARISING OUT OF ANY BREACH OF THE WARRANTY. ALL EXPRESS AND IMPLIED WARRANTIES, INCLUDING THE WARRANTIES OF MERCHANTABILITY AND FITNESS FOR PARTICULAR PURPOSE, ARE LIMITED TO THE APPLICABLE WARRANTY PERIOD SET FORTH ABOVE.

Some states do not allow the exclusion or limitation of incidental or consequential damages, or limitations on how long an implied warranty lasts, so the above exclusions or limitations may not apply to you.

This warranty gives you specific legal rights and you may also have other rights which vary from state to state.

If a problem with this product develops during or after the warranty period, you may contact your dealer or Servicenter. If the problem is not handled to your satisfaction, then write to the Customer Satisfaction Center at the Panasonic Consumer Electronics Company address above.

SERVICE CALLS WHICH DO NOT INVOLVE DEFECTIVE MATERIALS OR WORKMANSHIP AS DETERMINED BY THE WARRANTOR, IN ITS SOLE DISCRETION, ARE NOT COVERED. COSTS OF SUCH SERVICE CALLS ARE THE RESPONSIBILITY OF THE PURCHASER.

warvid 10/20/97

Panasonic Consumer Electronics Company,
Division of Matsushita Electric Corporation of America
One Panasonic way Secaucus,
New Jersey 07094

Printed in USA
VQTS3512B

Panasonic Sales Company,
Division of Matsushita Electric of
Puerto Rico, Inc. ("PSC")
Ave. 65 de Infanteria. Km. 9.5
San Gabriel Industrial Park, Carolina,
Puerto Rico 00985

