

***FM/AM
Cassette Car
Stereo***

Installation/Connections

Installation/Connexions

XR-1100

Parts for installation and connections

The numbers in the list correspond to those in the instructions.

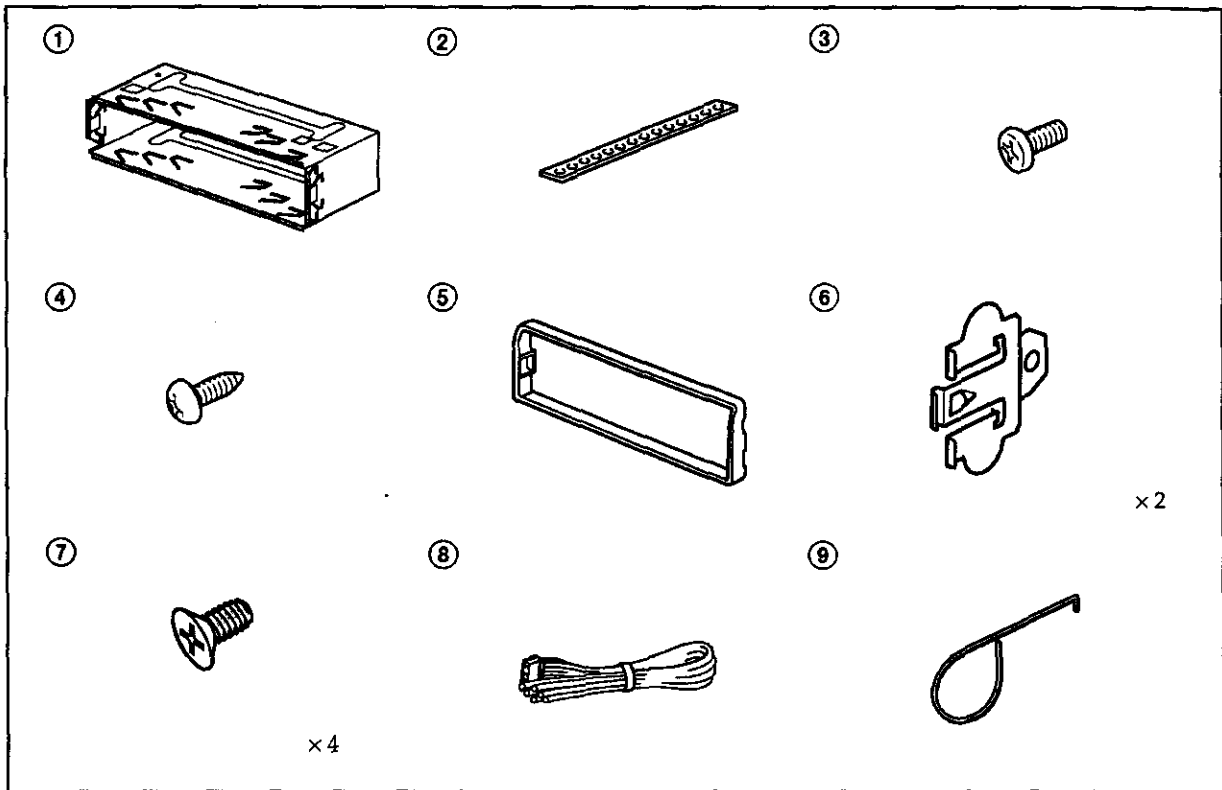

Caution

Cautionary notice for handling the bracket ①.
Handle the bracket carefully to avoid injuring your fingers.

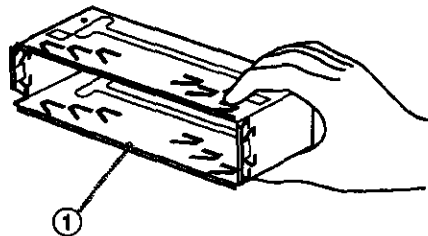

Note

The tool ⑨ is used for removing the unit.
Be sure to keep it for future use.

Connections

Caution

- This unit is designed for negative ground 12 V DC operation only.
- Before making connections, disconnect the ground terminal of the car battery to avoid short circuits.
- Connect the **yellow** and **red** power input leads only after all other leads have been connected.
- Be sure to connect the red power input lead to the positive 12 V power terminal which is energized when the ignition key is in the accessory position.
- **Run all ground wires to a common ground point.**

Connection diagram.

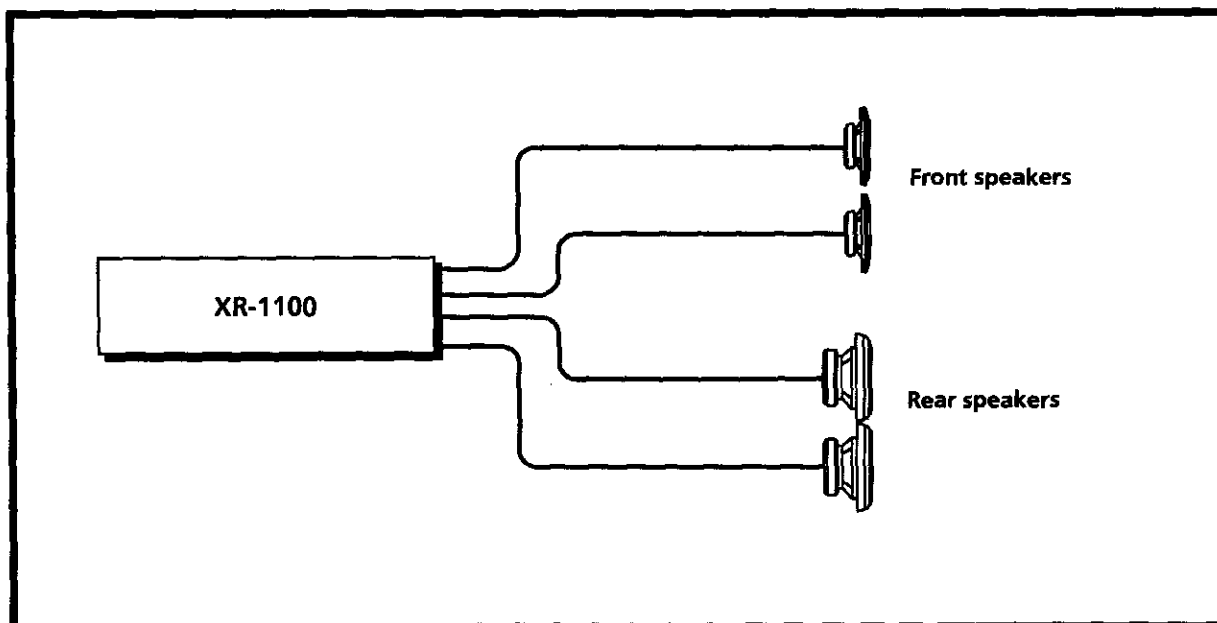

Speaker connections

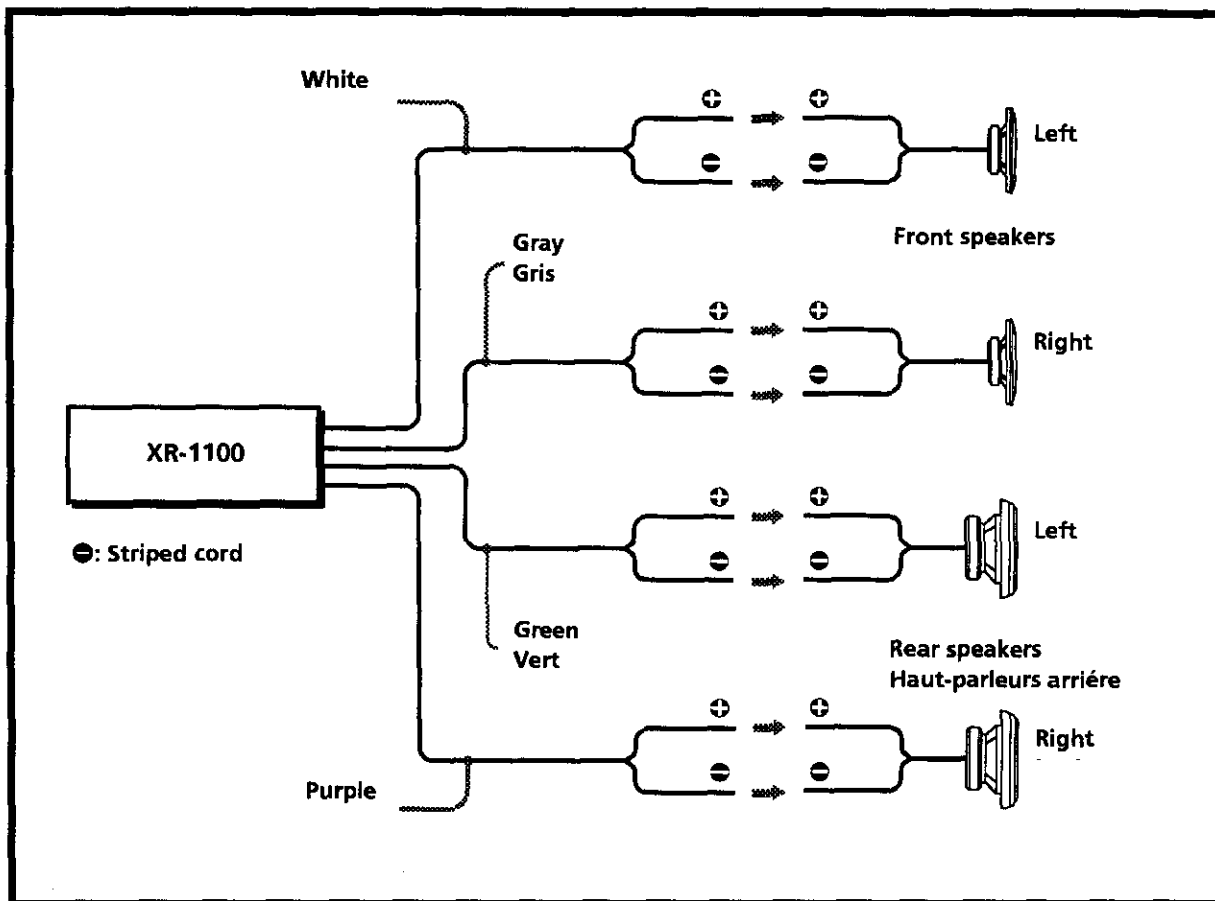

Notes on speaker connection

- Use speakers with an impedance of 4 to 8 ohms, and with adequate power handling capacities. Otherwise, the speakers may be damaged.
- Do not connect the terminals of the speaker system to the car chassis, and do not connect the terminals of the right speaker with those of the left speaker.
- Do not connect the speakers in parallel.
- Do not connect any active speakers (with built-in amplifiers) to the speaker terminals of the unit. Doing so may damage the active speakers. Therefore, be sure to connect passive speakers to these terminals.

Connection example.

to the +12 V power terminal which is energized in the accessory position of the ignition key switch.
Be sure to connect the black earth lead to it first.

to the +12 V power terminal which is energized at all times.
Be sure to connect the black earth lead first.

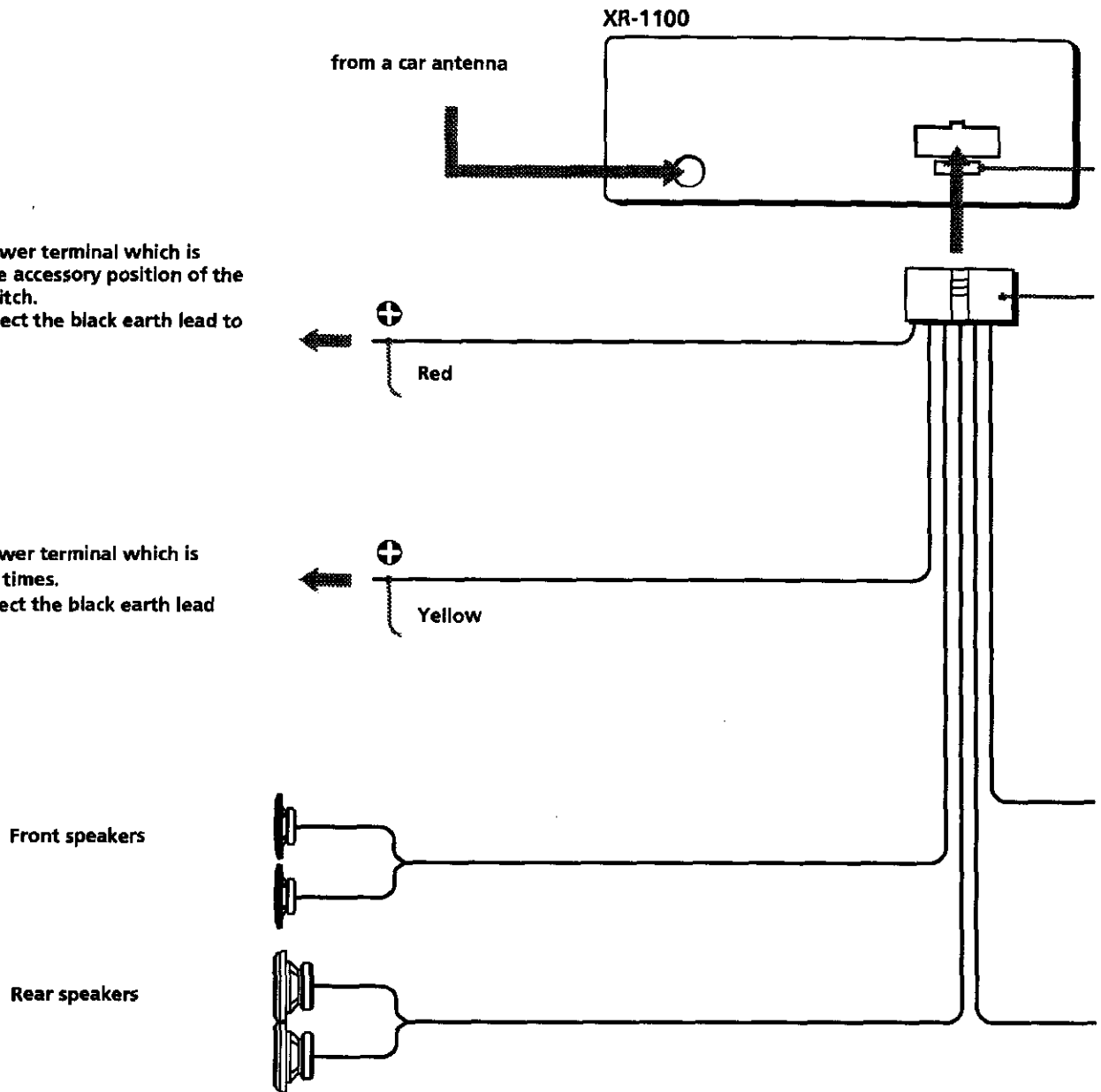

Notes on the control leads

- The power antenna control lead (blue) supplies 12V DC when you turn on the unit.
- When your car has a built-in FM/AM antenna in the rear side glass, it is necessary to connect the power antenna control lead (blue) or the accessory power input lead (red) to the power terminal of the existing antenna booster. For details, consult your dealer.
- A power antenna without relay box cannot be used with this unit.

-1100

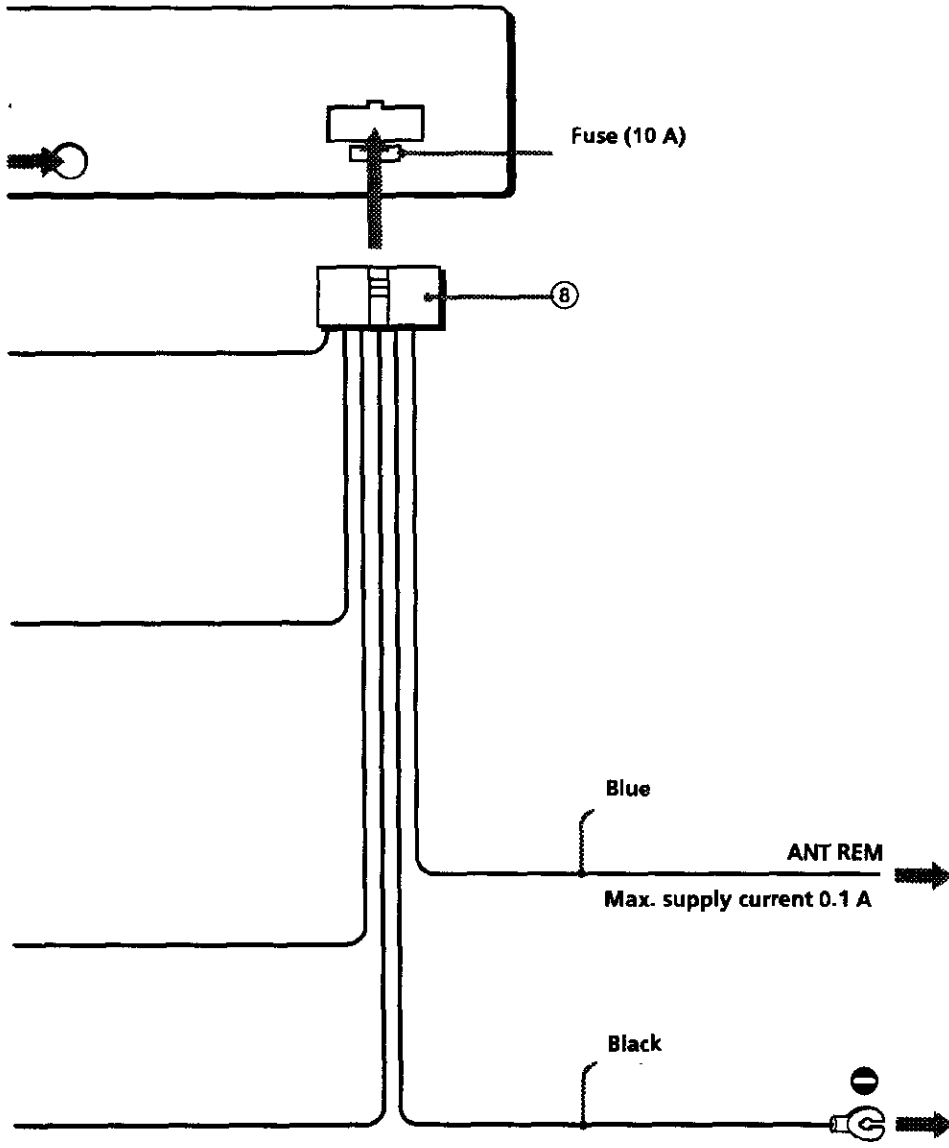

to the power antenna control lead or power supply lead of antenna booster amplifier

- Notes**
- It is not necessary to connect this lead if there is no power antenna or antenna booster, or with a manually-operated telescopic antenna.
 - When your car has a built-in FM/AM antenna in the rear/side glass, see "Notes on the control leads."

to a metal point of the car.
First connect the black earth lead, then connect the yellow and red power input leads.

Removing the unit

- 1 Insert the supplied tool ⑨ between the unit and the frame, and rotate 90° to release the hidden mounting spring. Repeat on the opposite side and remove the frame.
- 2 Insert a flathead screwdriver between the bracket and mounting spring. Gently pry the spring toward the unit while pulling the unit out a little. Repeat on the opposite side and remove the unit.

1

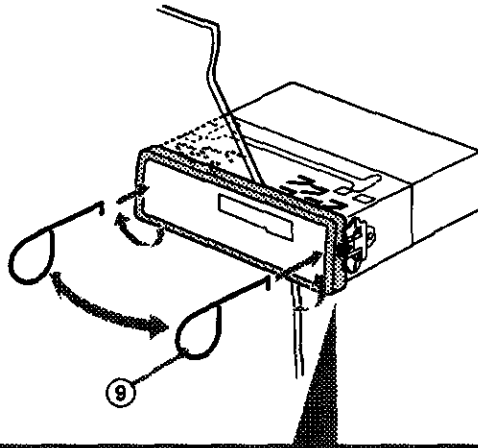

10 mm ($13/32$ in./po.)

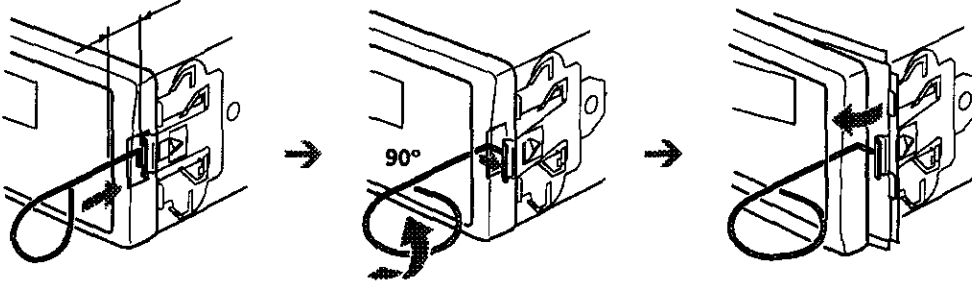

2

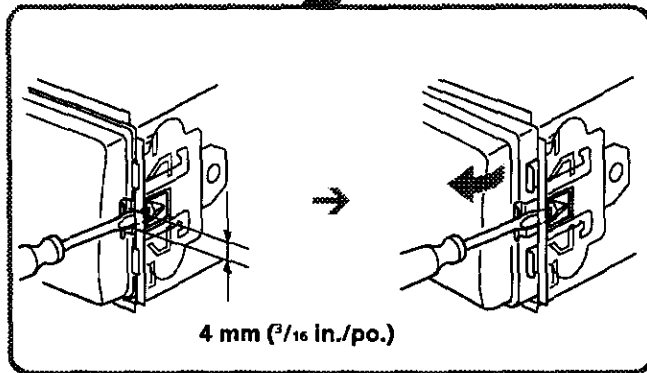
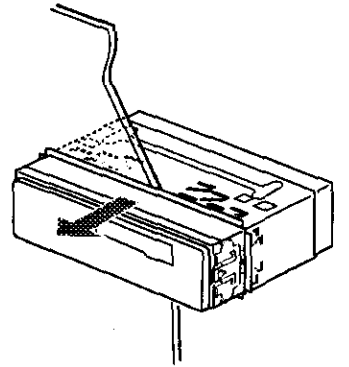
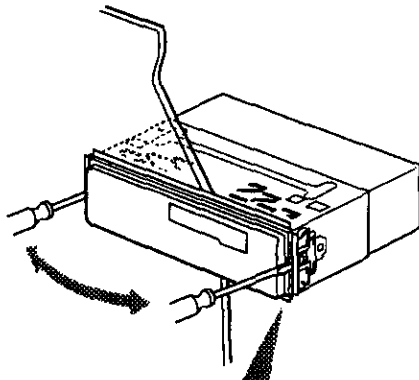

4 mm (1/16 in./po.)

Installation

Precautions

- Choose the installing location carefully so that the unit will not interfere with driving.
- Avoid installing the unit where it would be subject to high temperatures, such as direct sunlight or hot air from the heater, or where it would be subject to dust, dirt, or excessive vibration.
- Use only the supplied mounting hardware for safe and secure installation.

Mounting angle adjustment

Adjust the mounting angle to less than 20°.

Mounting example

Installing in the dashboard

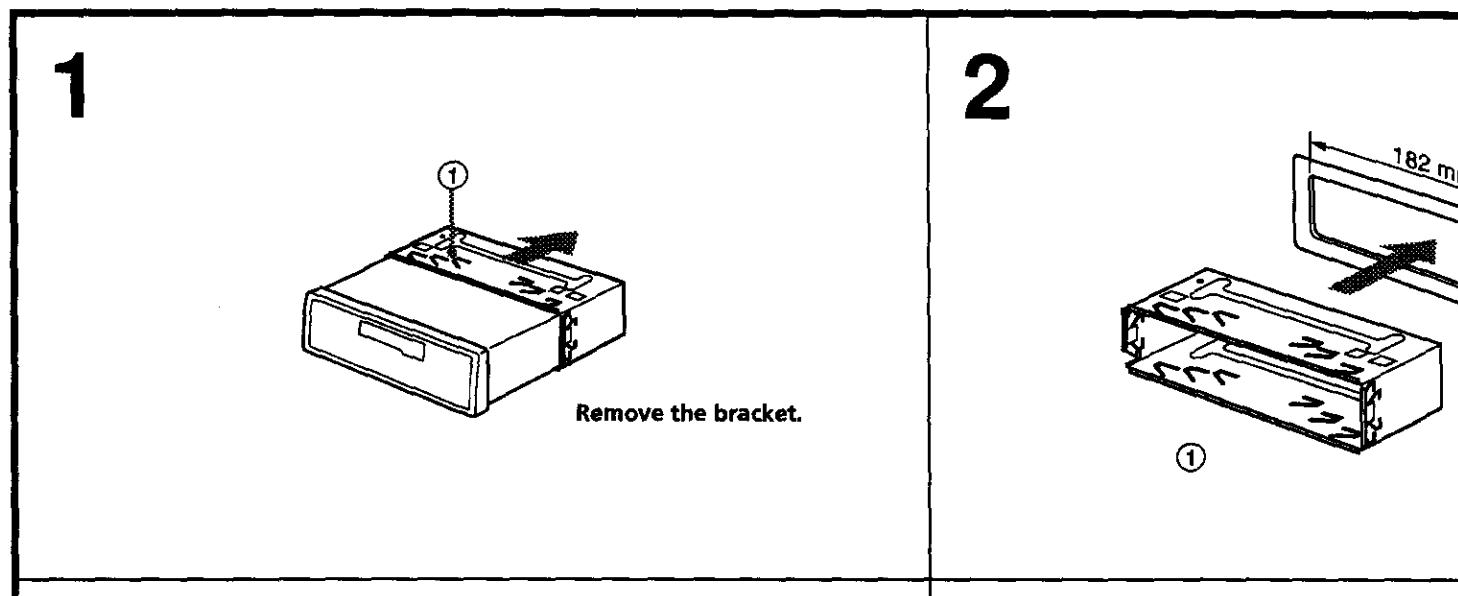

Installation

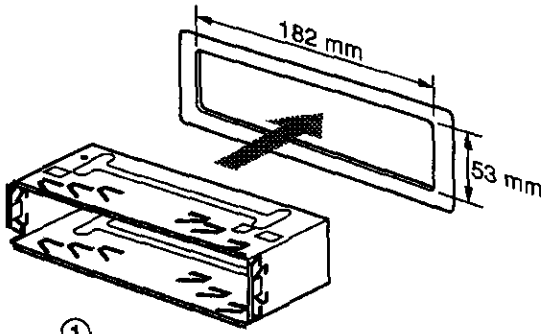

①

3

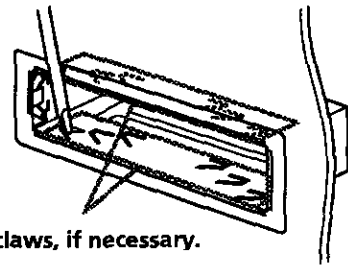

Bend these claws, if necessary.

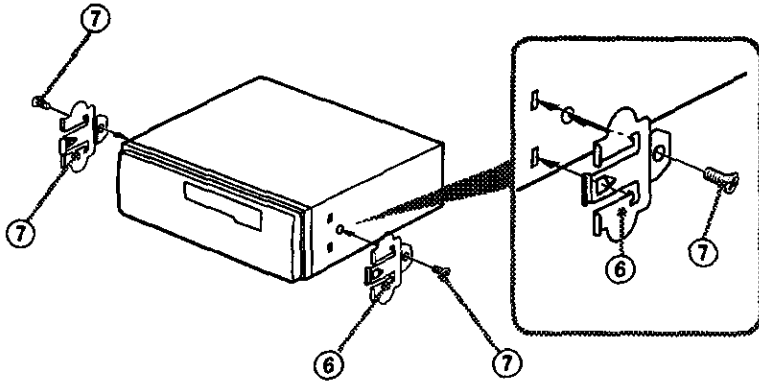
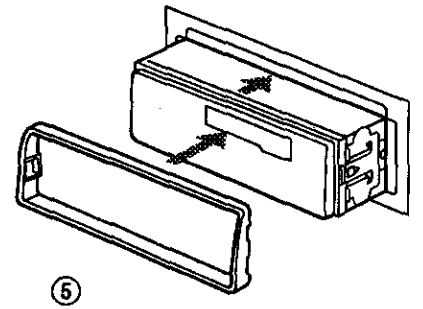
4**5**

Mounting the unit in a Japanese car

This unit may not be installed in some makes of cars. In this case, consult your nearest Sony dealer.

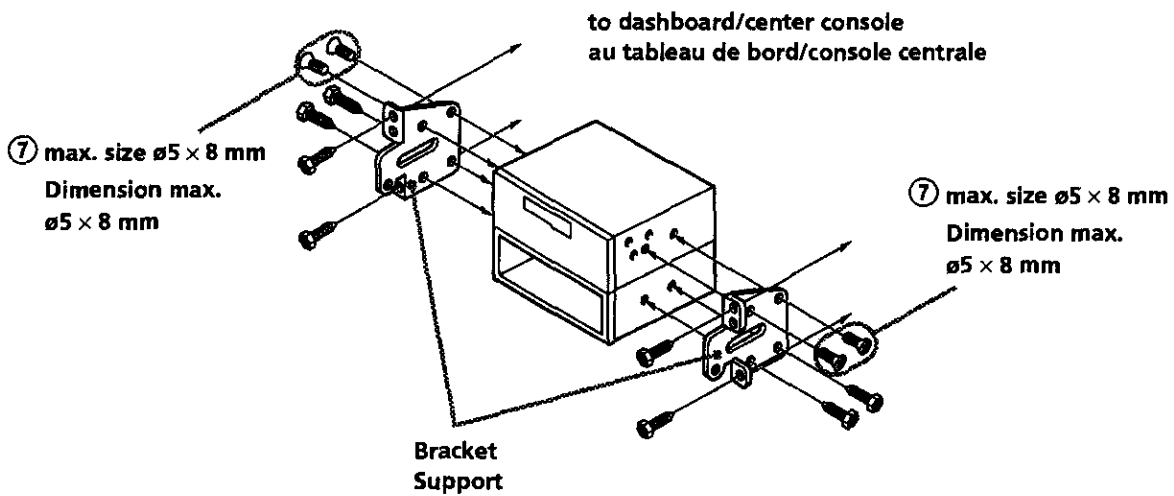
TOYOTA**NISSAN****Note**

To prevent malfunction, install only with the supplied screws ⑦.

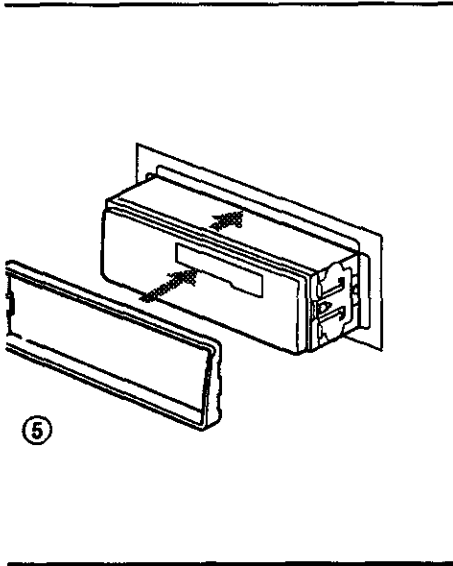

To support the unit

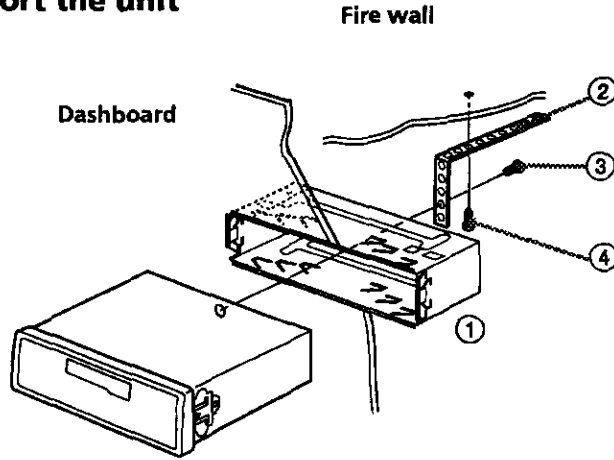

NISSAN

