

**SONY.**

***FM/AM  
Compact Disc  
Player***

---

Installation/Connections

***CDX-1200***

Sony Corporation ©2000



## Parts list

The numbers in the list are keyed to those in the instructions.

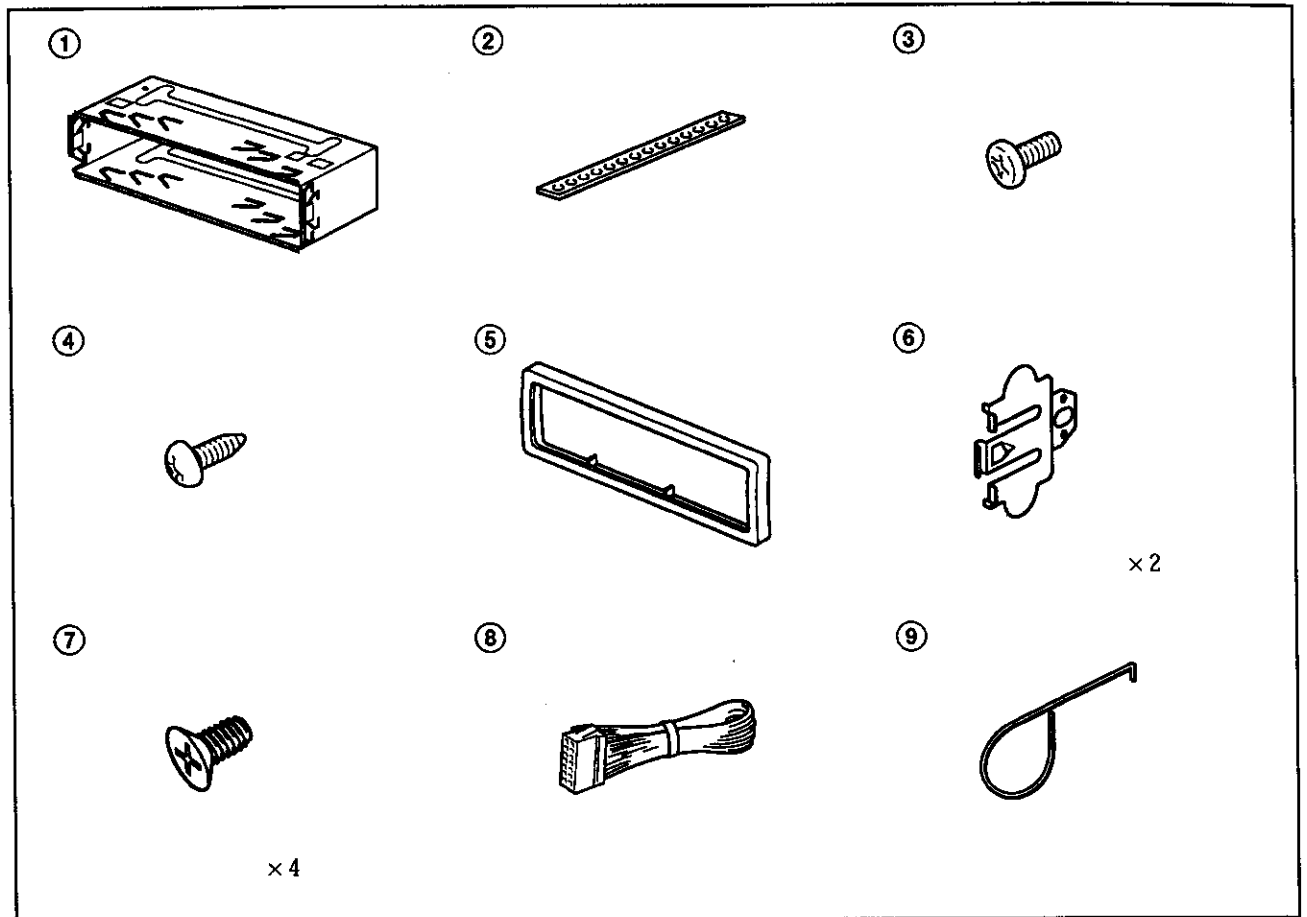

### Caution

Cautionary notice for handling the bracket ①.  
Handle the bracket carefully to avoid injuring your fingers.

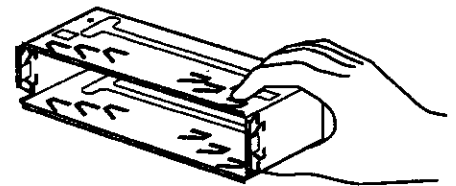

## Connection example

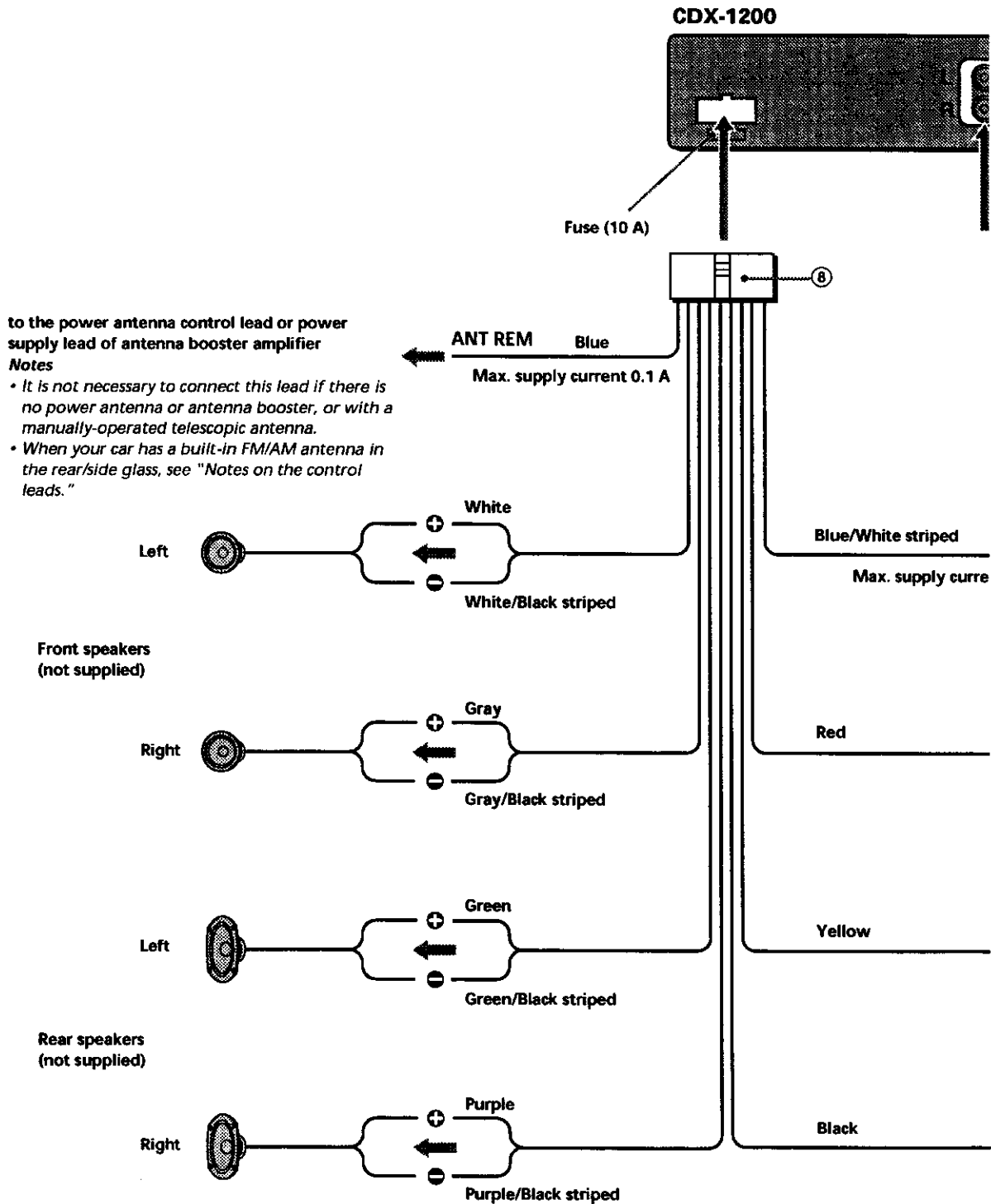

to the power antenna control lead or power supply lead of antenna booster amplifier

### Notes

- It is not necessary to connect this lead if there is no power antenna or antenna booster, or with a manually-operated telescopic antenna.
- When your car has a built-in FM/AM antenna in the rear/side glass, see "Notes on the control leads."

### Front speakers (not supplied)

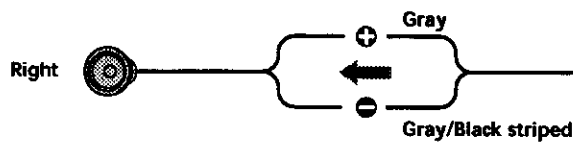
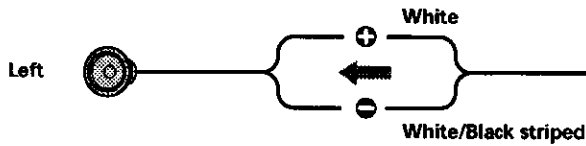

### Rear speakers (not supplied)

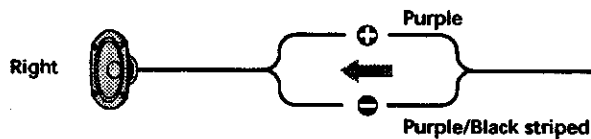
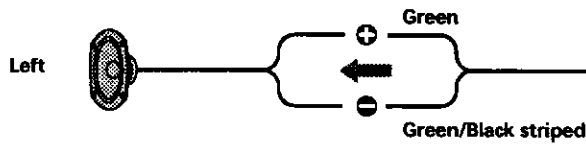

### Notes on the control leads

- The ANT REM lead (blue) supplies +12 V DC when you turn on the tuner.
- When your car has a built-in FM/AM antenna in the rear/side glass, it is necessary to connect the power antenna control lead (blue) or the accessory power input lead (red) to the power terminal of the existing antenna booster. For details, consult your dealer.
- A power antenna without relay box cannot be used with this unit.

### Memory hold connection

When the yellow power input lead is connected, power will always be supplied to the memory circuit even when the ignition key is turned off.

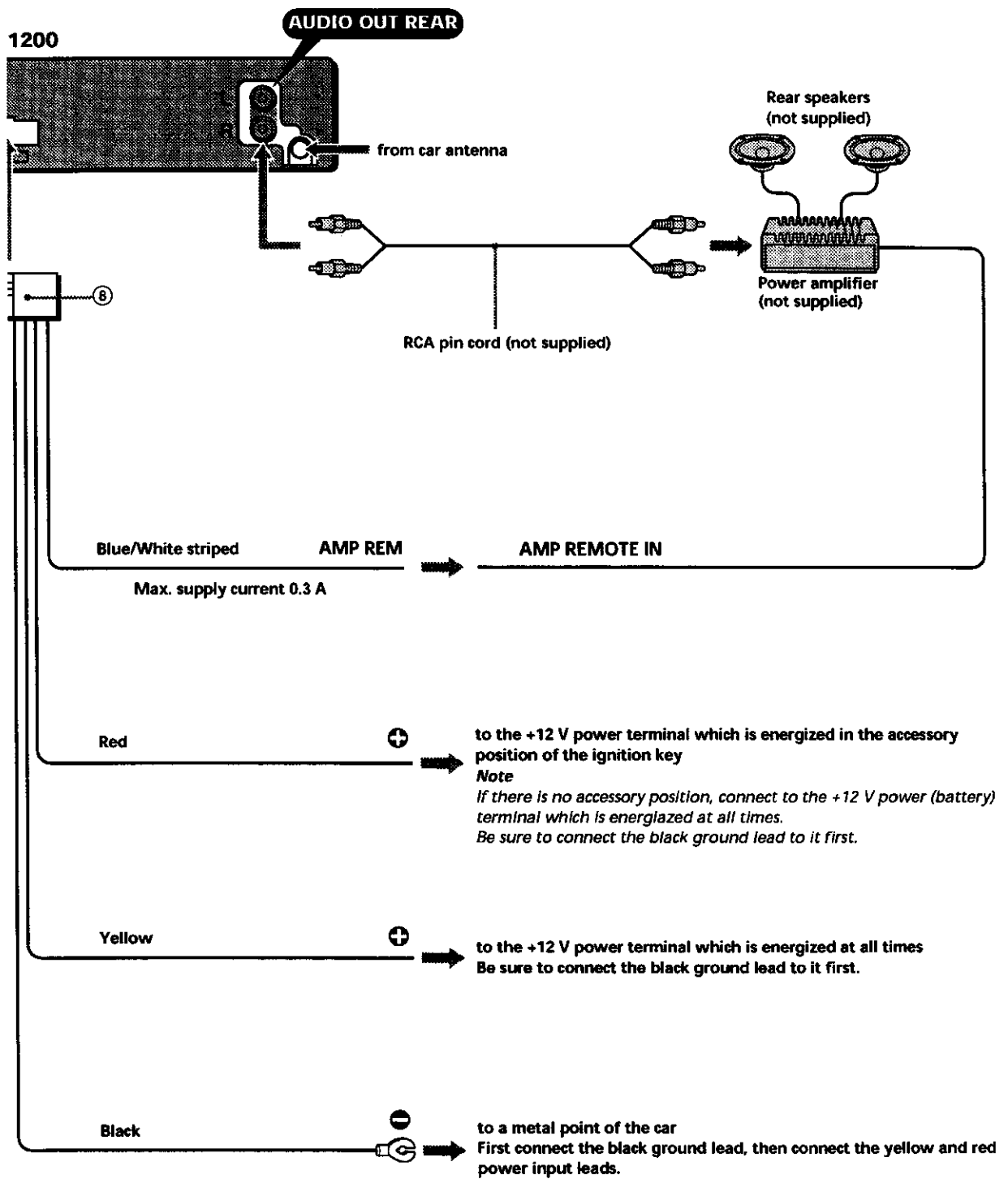

**Notes on speaker connection**

- Before connecting the speakers, turn the unit off.
- Use speakers with an impedance of 4 to 8 ohms, and with adequate power handling capacities. Otherwise, the speakers may be damaged.
- Do not connect the terminals of the speaker system to the car chassis, and do not connect the terminals of the right speaker with those of the left speaker.
- Do not attempt to connect the speakers in parallel.
- Do not connect any active speakers (with built-in amplifiers) to the speaker terminals of the unit. Doing so may damage the active speakers. Therefore, be sure to connect passive speakers to these terminals.

# Connection diagram

## Example 1

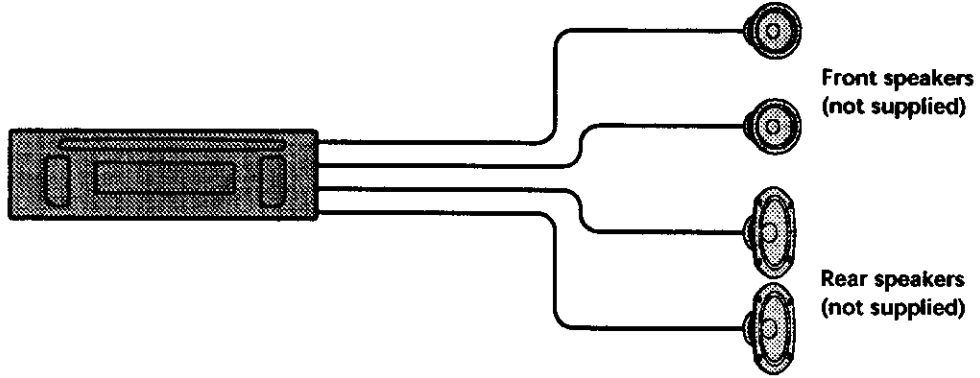

## Example 2

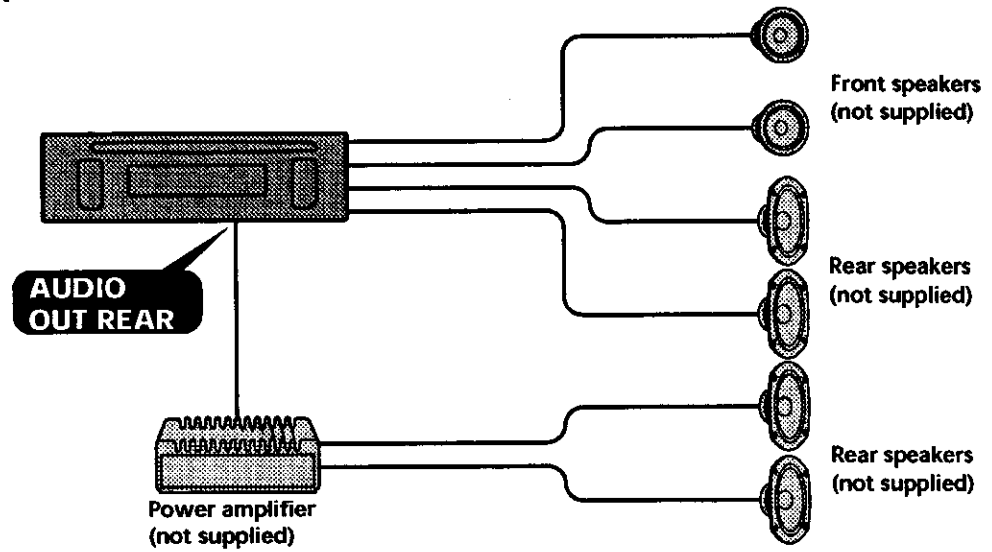

### Notes

- Be sure to connect the earth cord before connecting the amplifier.
- If you connect an optional power amplifier and do not use the built-in amplifier, the beep sound will be deactivated.

# Installation

## Precautions

- Do not tamper with the four holes on the upper surface of the unit. They are for tuner adjustments to be done only by service technicians.
- Choose the installation location carefully so that the unit will not hamper the driver during driving.
- Avoid installing the unit where it would be subject to high temperatures, such as from direct sunlight or hot air from the heater, or where it would be subject to dust, dirt or excessive vibration.
- Use only the supplied mounting hardware for a safe and secure installation.

## Mounting example

### Installation in the dashboard

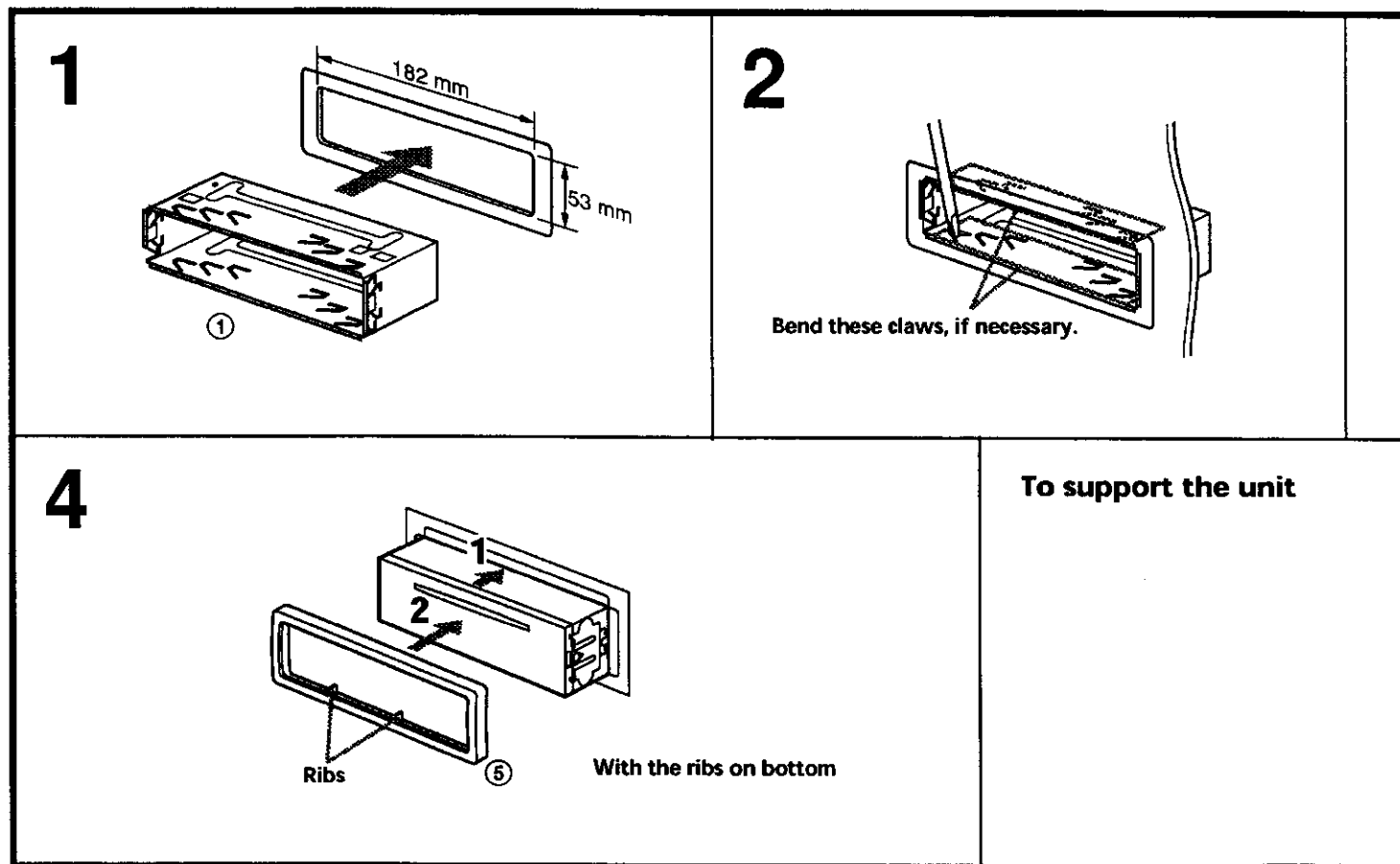



### Mounting angle adjustment

Adjust the mounting angle to less than 60 °.

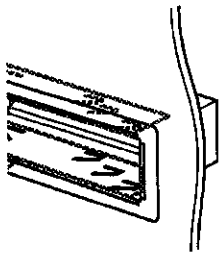

**3**

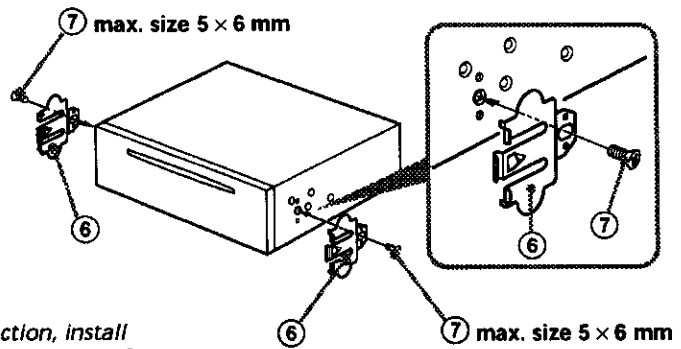

**Note**  
To prevent malfunction, install  
only with the supplied screws ⑦.

### To support the unit

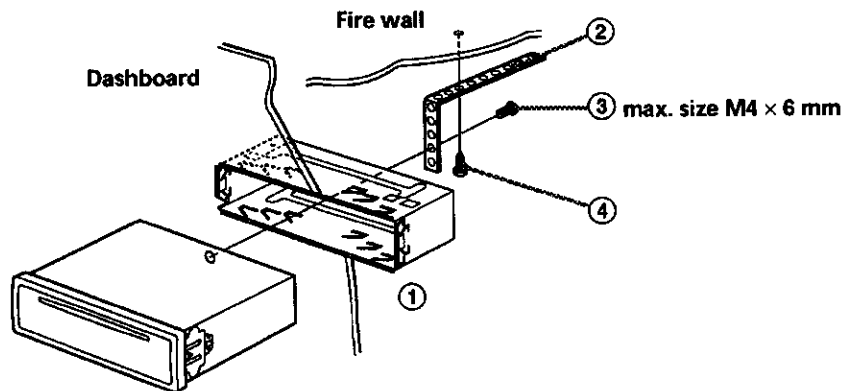

## Mounting the unit in a Japanese car

You may not be able to install this unit in some makes of Japanese cars. In such a case, consult your Sony dealer.

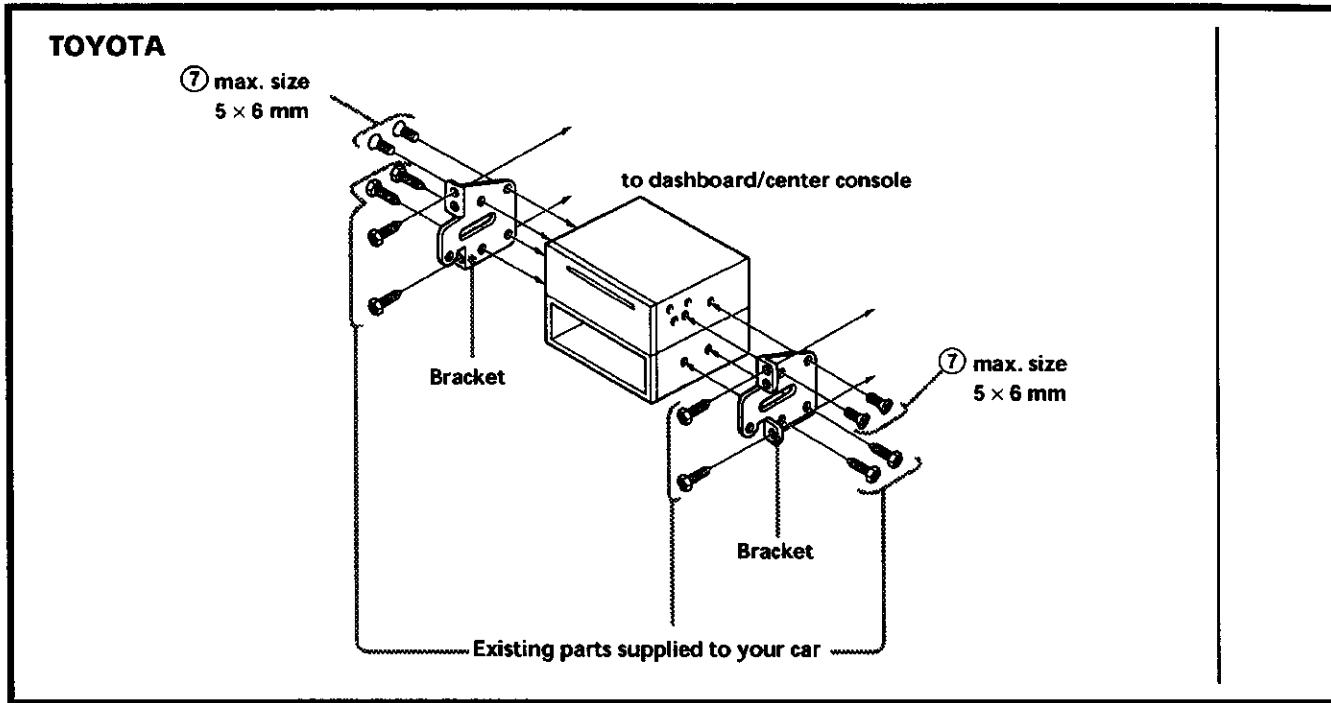

**Note**  
To prevent malfunction, install only with the supplied screws ⑦.

## Removing the unit

- 1** Insert the supplied tool ⑨ between the unit and the frame, and rotate 90° to release the hidden mounting spring. Repeat on the opposite side and remove the frame.

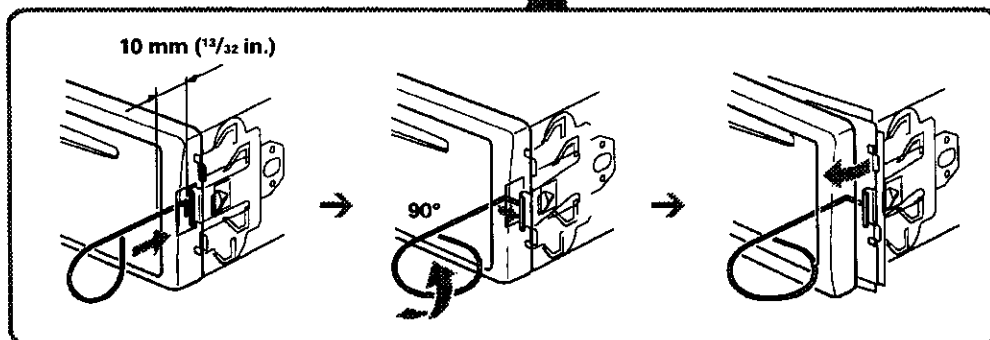
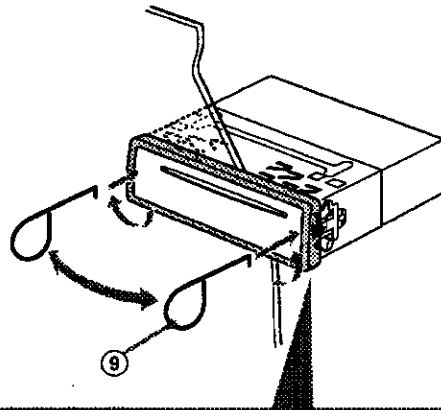

**2**

**NISSAN**

⑦ max. size  
5 × 6 mm

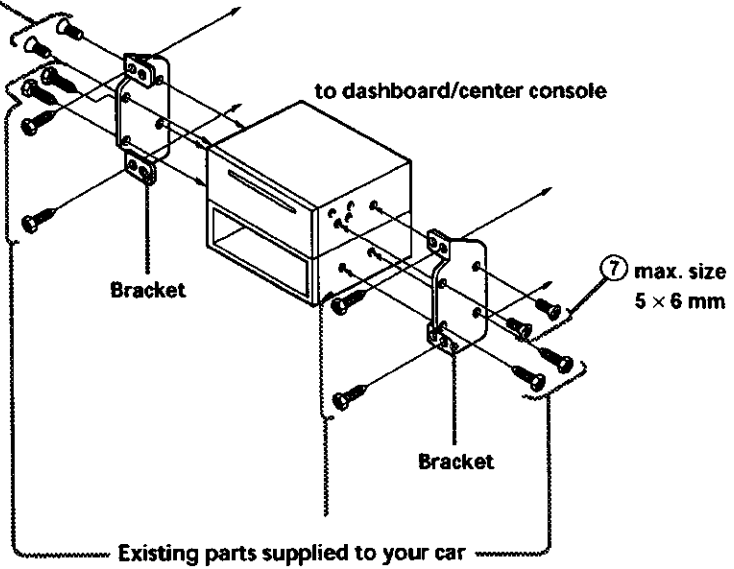

- 2** Insert a flathead screwdriver between the bracket and mounting spring. Gently pry the spring toward the unit while pulling the unit out a little. Repeat on the opposite side and remove the unit.

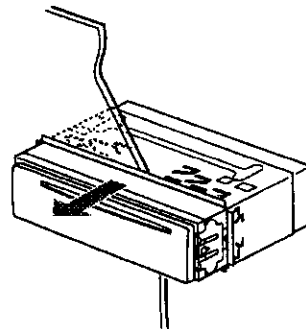
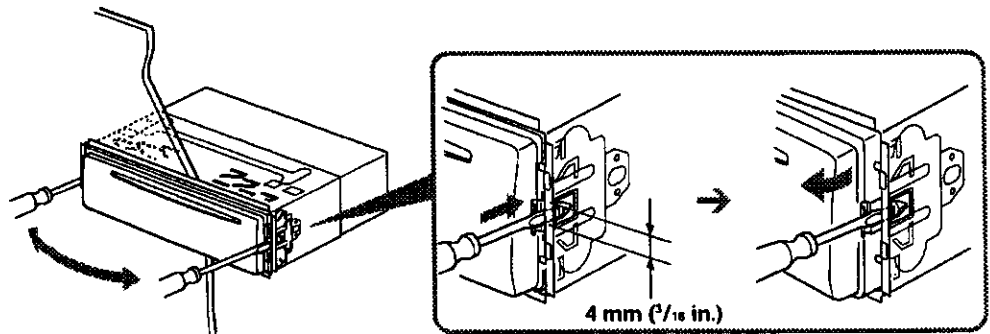

# Connections

---

## Caution

- This unit is designed for negative ground 12 V DC operation only.
- Before making connections, disconnect the ground terminal of the car battery to avoid short circuits.
- Connect the **yellow** and **red** power input leads only after all other leads have been connected.
- Be sure to connect the red power input lead to the positive 12 V power terminal which is energized when the ignition key is in the accessory position.
- **Run all ground wires to a common ground point.**
- Connect the yellow cord to a free car circuit rated higher than the unit's fuse rating.  
If you connect this unit in series with other stereo components, the car circuit they are connected to must be rated higher than the sum of the individual component's fuse rating.  
If there are no car circuits rated as high as the unit's fuse rating, connect the unit directly to the battery.
- If no car circuits are available for connecting this unit, connect the unit to a car circuit rated higher than the unit's fuse rating in such a way that if the unit blows its fuse, no other circuits will be cut off.
- The use of optical instruments with this product will increase eye hazard.

---

## Reset button

When the installation and connections are over, be sure to press the reset button with a ball-point pen etc.

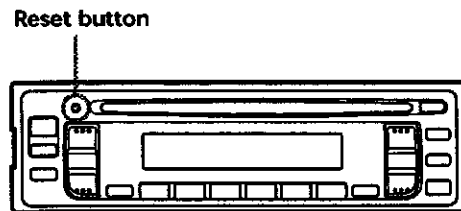

**Note**  
When you connect the power supply cord to the unit or reset the unit, wait for about 10 seconds before you insert a disc. If you insert a disc within these 10 seconds, the unit will not be reset, and you will have to press the reset button again.

---

## Warning when installing in a car without ACC (accessory) position on the ignition key switch

Be sure to press **OFF** on the unit for two seconds to turn off the clock display after turning off the engine.

When you press **OFF** momentarily, the clock display does not turn off and this causes battery wear.



Sony Corporation Printed in USA



\* 1 - 3 - 0 4 3 - 4 6 3 - 1 2 \* (1)