

**SONY®**

3-867-106-12(1)

# ***Mini Hi-Fi Component System***

---

Operating Instructions

Owner's Record

The model and serial numbers are located on the rear panel. Record the serial number in the space provided below. Refer to them whenever you call upon your Sony dealer regarding this product.

Model No. \_\_\_\_\_ Serial No. \_\_\_\_\_



***MHC-NX1***

©1999 by Sony Corporation

## WARNING

To prevent fire or shock hazard, do not expose the unit to rain or moisture.

To avoid electrical shock, do not open the cabinet  
Refer servicing to qualified personnel only

Do not install the appliance in a confined space, such as a bookcase or built-in cabinet

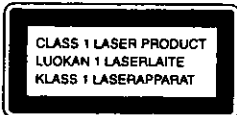

This appliance is classified as a CLASS 1 LASER product. The CLASS 1 LASER PRODUCT MARKING is located on the rear exterior

## NOTICE FOR THE CUSTOMERS IN THE U.S.A.

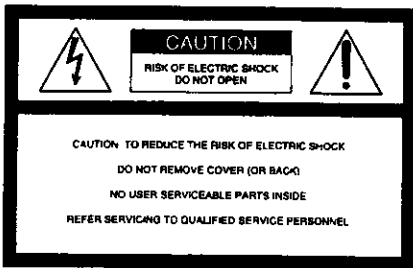

This symbol is intended to alert the user to the presence of uninsulated "dangerous voltage" within the product's enclosure that may be of sufficient magnitude to constitute a risk of electric shock to persons.



This symbol is intended to alert the user to the presence of important operating and maintenance (servicing) instructions in the literature accompanying the appliance.

### CAUTION

The use of optical instruments with this product will increase eye hazard

## INFORMATION

This equipment has been tested and found to comply with the limits for a Class B digital device, pursuant to Part 15 of the FCC Rules. These limits are designed to provide reasonable protection against harmful interference in a residential installation. This equipment generates, uses, and can radiate radio frequency energy and, if not installed and used in accordance with the instructions, may cause harmful interference to radio communications. However, there is no guarantee that interference will not occur in a particular installation. If this equipment does cause harmful interference to radio or television reception, which can be determined by turning the equipment off and on, the user is encouraged to try to correct the interference by one or more of the following measures

- Reorient or relocate the receiving antenna
- Increase the separation between the equipment and receiver.
- Connect the equipment into an outlet on a circuit different from that to which the receiver is connected
- Consult the dealer or an experienced radio/TV technician for help.

### CAUTION

You are cautioned that any changes or modifications not expressly approved in this manual could void your authority to operate this equipment

## NOTICE FOR THE CUSTOMERS IN CANADA

### CAUTION:

TO PREVENT ELECTRIC SHOCK, DO NOT USE THIS POLARIZED AC PLUG WITH AN EXTENSION CORD, RECEPTACLE OR OTHER OUTLET UNLESS THE BLADES CAN BE FULLY INSERTED TO PREVENT BLADE EXPOSURE.

This stereo system is equipped with the Dolby B-type noise reduction system\*

\* Manufactured under license from Dolby Laboratories Licensing Corporation  
DOLBY and the double-D symbol  are trademarks of Dolby Laboratories Licensing Corporation



АЯ46

The MHC-NX1 consist of the following components

- A/V control amplifier STR-NX1
- CD player/Stereo cassette deck HTC-NX1
- Speaker system SS-NX1

---

# Table of Contents

---

## Getting Started

- Step 1: Hooking up the system ..... 4
- Step 2: Setting the time ..... 7
- Step 3: Presetting radio stations ..... 8
- Saving the power in standby mode ..... 9

## Basic Operations

- Playing a CD ..... 10
- Recording a CD ..... 11
- Listening to the radio ..... 12
- Recording from the radio ..... 14
- Playing a tape ..... 15
- Recording from a tape ..... 17

## The CD Player

- Using the CD display ..... 18
- Playing the CD tracks repeatedly ..... 19
- Playing the CD tracks in random order  
..... 19
- Programming the CD tracks ..... 20

## The Tape Deck

- Recording on a tape manually ..... 22
- Recording a CD by specifying track  
order ..... 23

## Sound Adjustment

- Adjusting the sound ..... 25
- Selecting the audio emphasis ..... 26
- Changing the brightness of  
the display ..... 27
- Selecting the surround effects ..... 27
- Adjusting the graphic equalizer ..... 28
- Making a personal audio  
emphasis file ..... 29

## Other Features

- Using the Radio Data System (RDS)\* 30
- Falling asleep to music ..... 32
- Waking up to music ..... 33
- Timer-recording radio programmes.. 34

## Optional components

- Connecting audio components ..... 35
- Connecting a VCR ..... 36
- Connecting external antennas ..... 37

## Additional Information

- Precautions ..... 38
- Troubleshooting ..... 39
- Specifications ..... 42
- Index ..... Back cover

\* European model only.

## Getting Started

### Step 1: Hooking up the system

Do the following procedure **1** to **5** to hook up your system using the supplied cords and accessories.

***If you set up the stereo system vertically***

Be sure to place the A/V control amplifier on top of the CD player/stereo cassette deck.

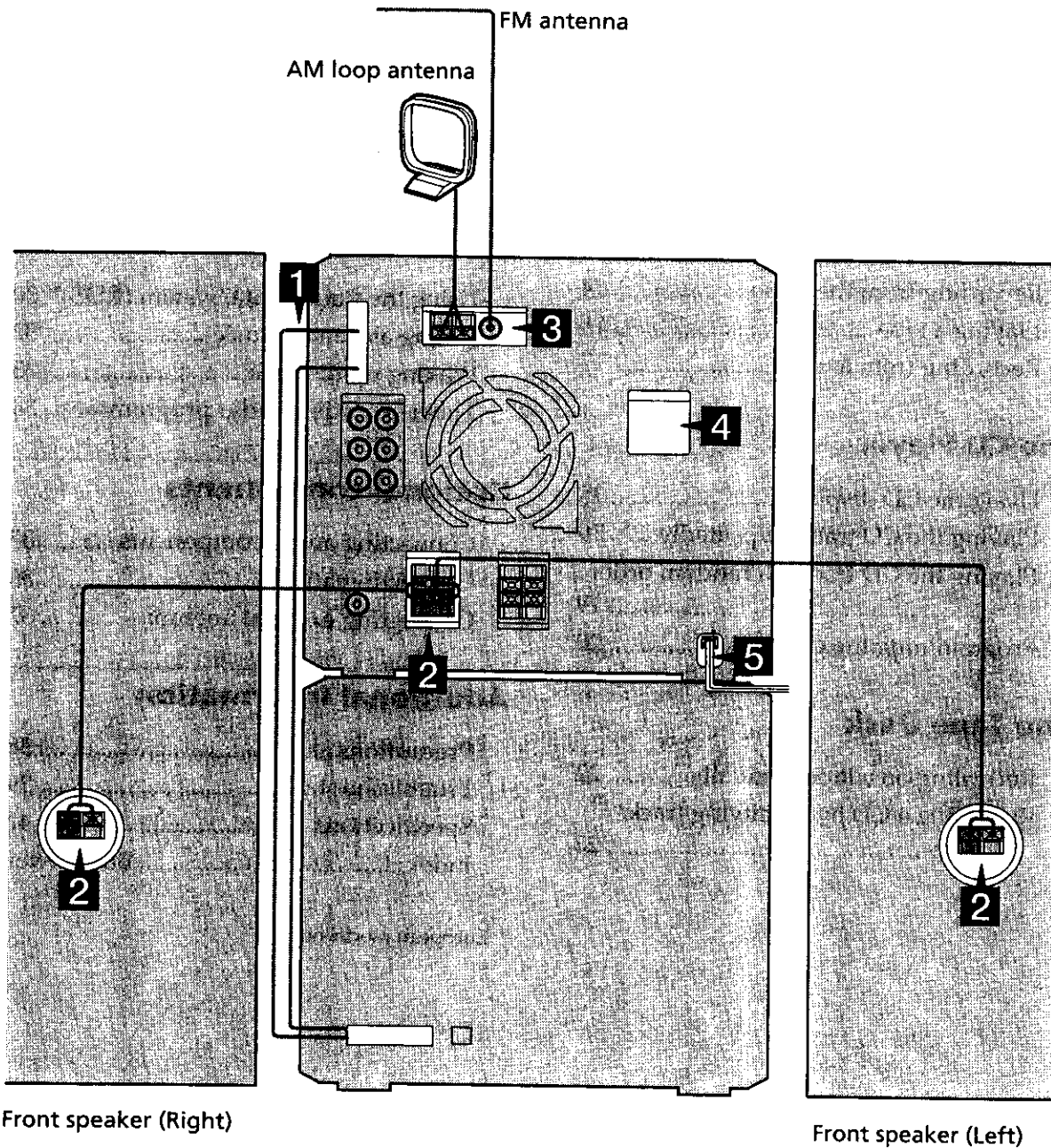

**Note on installing**

Be sure to place the A/V control amplifier on top as shown in the illustration. When the A/V control amplifier is placed under the CD player/stereo cassette deck, noise may be produced when playing tapes.

- 1** Connect the flat cord to the SYSTEM CONTROL connectors until it clicks.

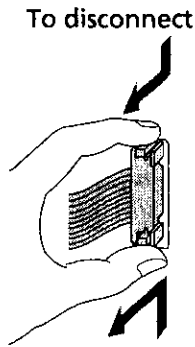

- 2** Connect the front speakers. Connect the speaker cords to the FRONT SPEAKER jacks as below.

Insert only the stripped portion.

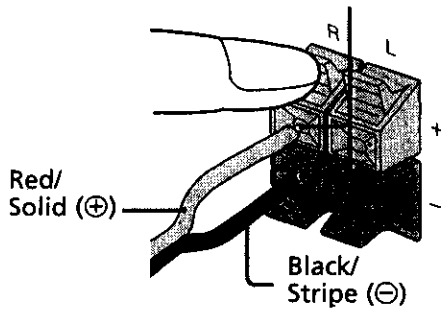

**Note**  
Keep the speaker cords away from the antennas to prevent noise.

- 3** Connect the FM/AM antennas. Set up the AM loop antenna, then connect it.

**Jack type (A)**

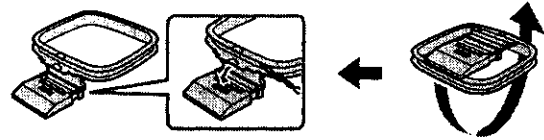
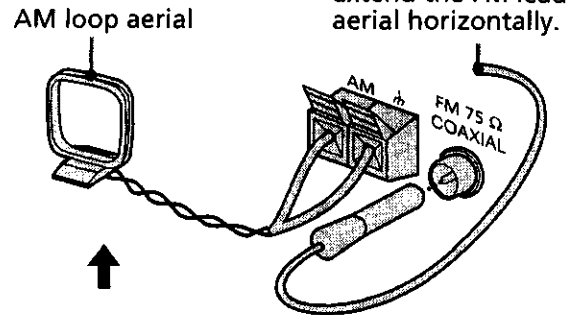

**Jack type (B)**

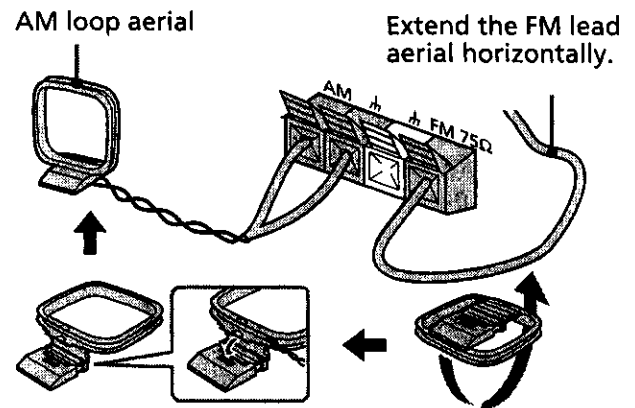

**Note**  
Set up the AM loop antenna as far as possible from the main unit.

continued

## Step 1: Hooking up the system (continued)

- 4** For models with a voltage selector, set VOLTAGE SELECTOR to position of your local power line voltage.

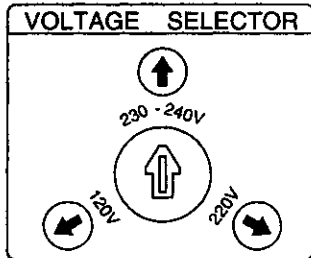

- 5** Connect the power cord to a wall outlet.

The demonstration appears in the display. When you press I/⏻, the system turns on and the demonstration automatically ends.

If the supplied adapter on the plug does not fit your wall outlet, detach it from the plug (only for models equipped with an adapter).

### To connect optional components

See page 35.

### To deactivate the demonstration

When you set the time (Step 2: Setting the time), the demonstration is deactivated.

To activate/deactivate the demonstration again, press DISPLAY (U.S.A., Canadian and European models) or DEMO (STANDBY) (other models) while the system is off.

#### Tip

You can reinforce the bass sound by connecting an optional super woofer to the super woofer connector.

### To attach the front speaker pads

Attach the supplied front speaker pads to the bottom of the speakers to stabilize the speakers and prevent them from slipping.

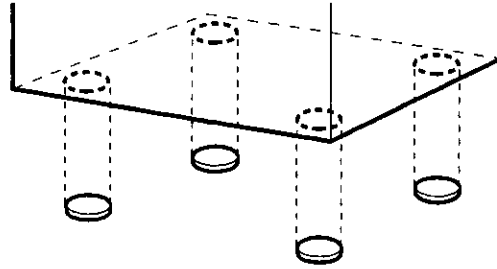

### Inserting two size AA (R6) batteries into the remote

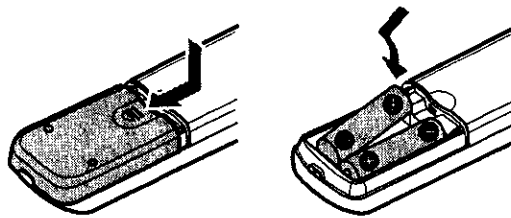

#### Tip

With normal use, the batteries should last for about six months. When the remote no longer operates the system, replace both batteries with new ones.

#### Note

If you do not use the remote for a long period of time, remove the batteries to avoid possible damage from battery leakage.

### When carrying this system

Do the following to protect the CD mechanism.

- 1 Press CD (or FUNCTION on the remote repeatedly) until "CD" appears in the display.
- 2 Hold down ENTER and press I/⏻ so that "LOCK" appears in the display.

## Step 2: Setting the time

You must set the time before using the timer functions.

The clock is on a 24-hour system for the European model, and a 12-hour system for other models.

The 24-hour system model is used for illustration purposes.

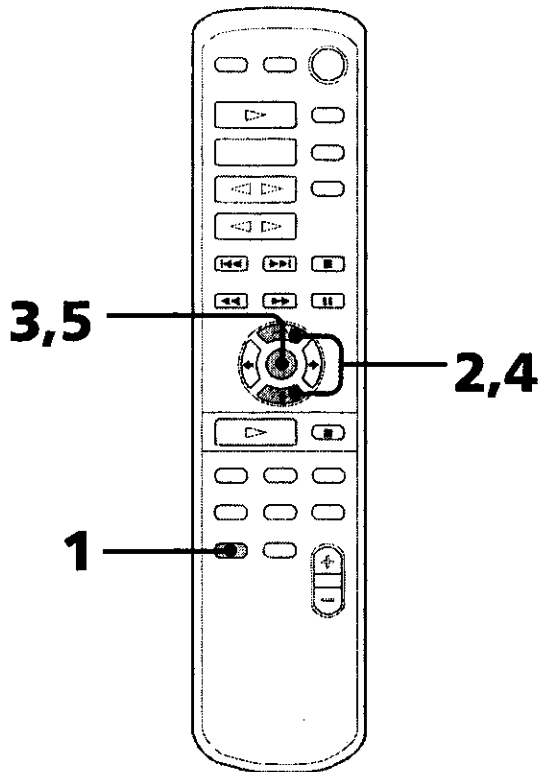

- 1 Press **CLOCK/TIMER**.  
The hour indication flashes.

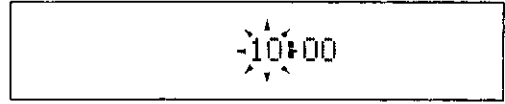

- 2 Press **▲** or **▼** to set the hour.  
The clock is on a 24-hour system for the European model and a 12-hour system for other models.

- 3 Press **ENTER**.  
The minute indication flashes.

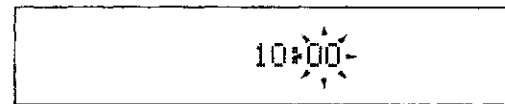

- 4 Press **▲** or **▼** to set the minute.

- 5 Press **ENTER**.  
The clock starts working.

### Tips

- If you've made a mistake, start over from step 1.
- Setting the time deactivates the demo mode.  
If you want to display the demo mode, press **DISPLAY** (U.S.A., Canadian and European models) or **DEMO (STANDBY)** (other models) when the power is off.

### To change the time

The previous explanation shows you how to set the time while the power is off. To change the time while the power is on, do the following:

- 1 Press **CLOCK/TIMER**.
- 2 Press **▲** or **▼** to select the **SET CLOCK**.
- 3 Press **ENTER**.
- 4 Perform steps 2 through 5 above.

### Note

The clock settings are cancelled when you disconnect the power cord or if a power failure occurs.

## Step 3: Presetting radio stations

You can preset the following number of stations:

- 2 band model: 20 for FM, 10 for AM.
- 3 band model: 20 for FM, 10 for MW, and 10 for SW, or 20 for FM, 10 for AM and 5 for UKV, depending on the model you purchased.

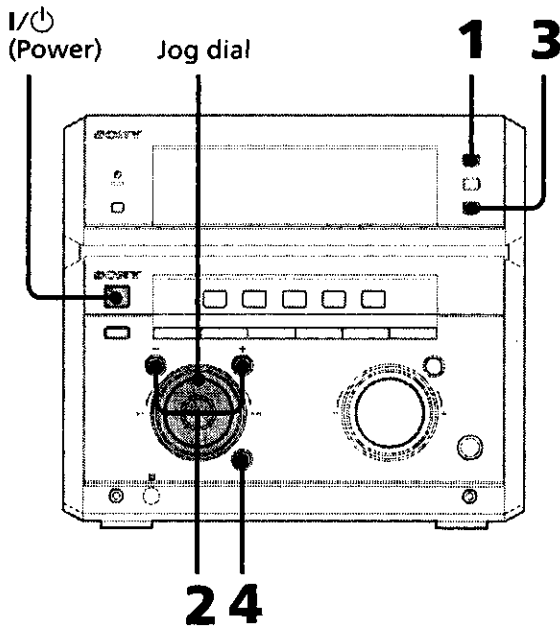

- 1** Press TUNER BAND repeatedly until the band you want appears in the display.

The bands you can receive vary depending on the model you purchased. Be sure to check which bands you can receive.

Every time you press this button, the band changes as follows:

2 band model:

FM ↔ AM

3 band model:

FM → MW → SW



or

FM → AM → UKV\*



\* "STEREO PLUS" is displayed when you select UKV.

- 2** Press and hold + or - until the frequency indication starts to change, then release.

Scanning stops when the system tunes in a station. "TUNED" and "STEREO" (for a stereo program) appear.

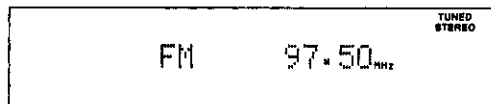

- 3** Press TUNER MEMORY.

A preset number flashes in the display. The stations are stored from preset number 1.

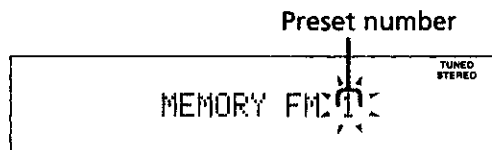

- 4** Press ENTER. The station is stored.

- 5** Repeat steps 1 to 4 to store other stations.



## To tune in a station with a weak signal

Press + or – repeatedly in step 2 to tune in the station manually.

## To set another station to the exist preset number

Start over from step 1. After step 3, turn the jog dial to select the preset number you want to store the other station.

You can add a new preset number after the last preset number.

## To erase a preset station

- 1 Keep pressing TUNER MEMORY until a preset number flashes in the display.

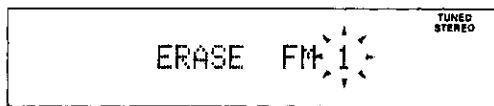

- 2 Turn the jog dial to select the preset number you want to erase. Select "ALL ERASE" when you want to erase all the preset stations.
- 3 Press ENTER. "COMPLETE!!" appears.

When you erase a preset number, the preset number decreases by one and all preset numbers following the erased one are renumbered.

## To change the AM tuning interval (Except for European and Middle Eastern models)

The AM tuning interval is factory set to 9 kHz (10 kHz in some areas). To change the AM tuning interval, tune in any AM station first, then turn off the power. While holding down the TUNER MEMORY button, press I/⏻ to turn the power back on. When you change the interval, AM preset stations will be erased. To reset the interval, repeat the same procedure.

### Tip

The preset stations are retained for half a day even if you unplug the power cord or if a power failure occurs.

# Saving the power in standby mode

## (U.S.A., Canadian and European models only)

You can lower the power consumption to a minimum (Power Saving Mode) and save energy in the standby mode.

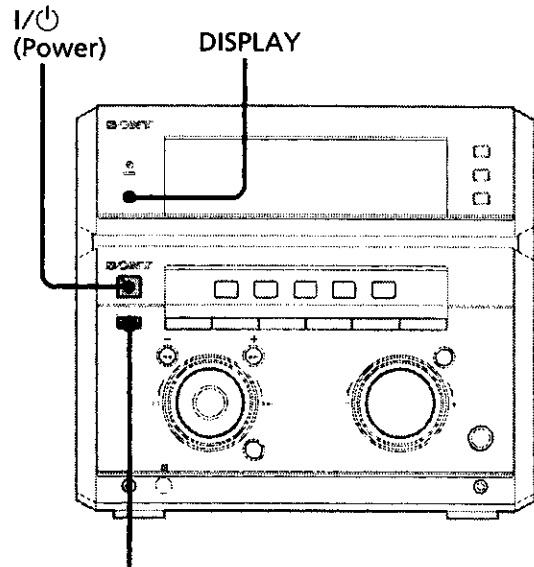

## POWER SAVE/DEMO (STANDBY)

- ➔ Press POWER SAVE/DEMO (STANDBY) when the power is off. The system switches to the Power Saving Mode and the clock display disappears. The system is powering on/off by pressing I/⏻.

### Tips

- Each time you press POWER SAVE/DEMO (STANDBY) in the Power Saving Mode, the display switches between the Power Saving Mode and the demo mode.
- I/⏻ indicator and timer indicator (when the timer is set) light up even in the Power Saving Mode.
- The timer works in the Power Saving Mode.

### Notes

- You cannot set the time in the Power Saving Mode.
- One Touch Play function does not work in the Power Saving Mode.

## To cancel the Power Saving Mode

Press DISPLAY.

The clock display appears.

# Basic Operations

## Playing a CD

### — Normal play

You can play up to five CDs in a row.

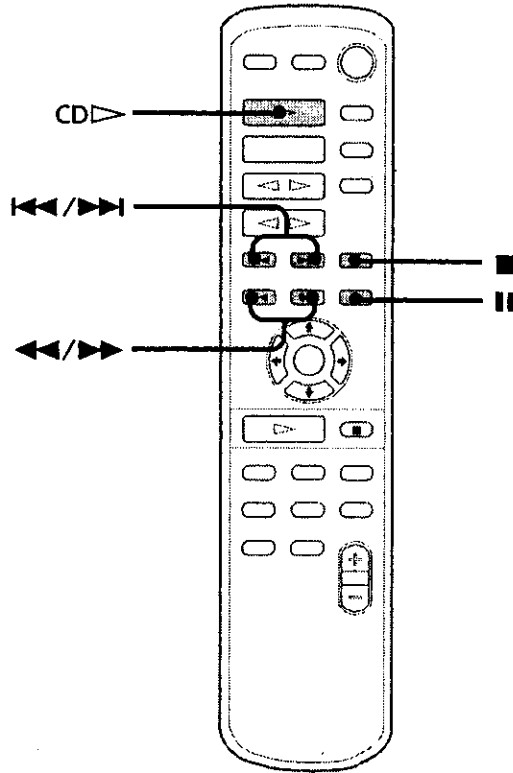
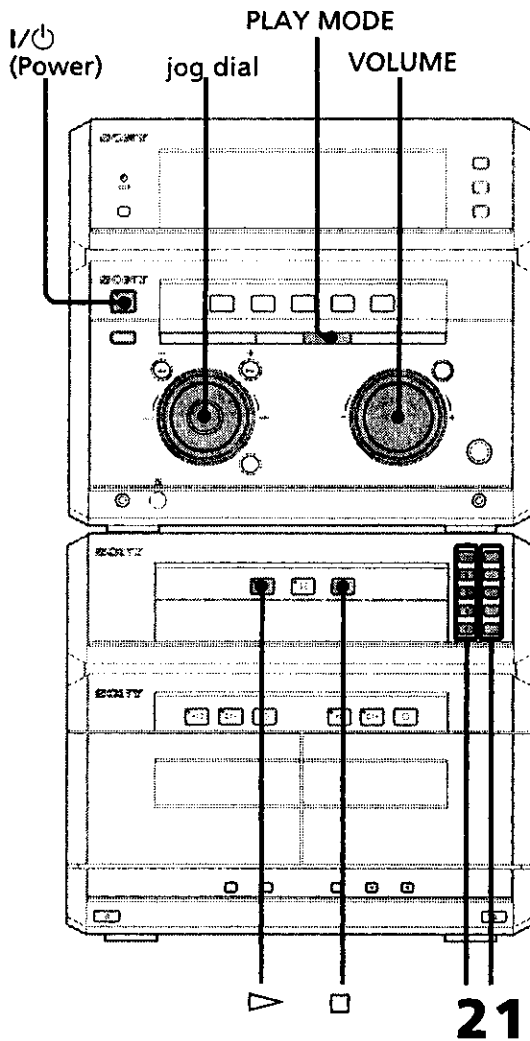

- 1 Press one of the CD 1~5 buttons and place a CD on the disc tray. If a disc is not placed properly it will not be recognized.

With the label side up. When you play a CD single, place it on the inner circle of the tray.

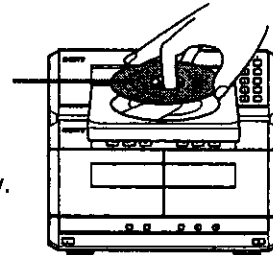

Press the same button to close the disc tray. To insert other CDs, press of other numbers to open the disc tray.

- 2 Press one of the DISC 1~5 buttons. The disc tray closes and play starts. If you press (or CD on the remote), play starts from the CD loaded on the tray whose button is lit green.

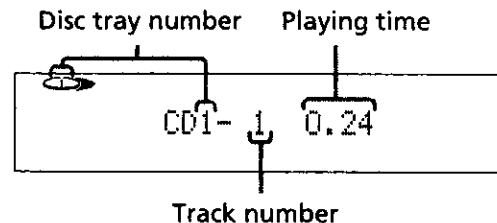

To	Do this
Stop play	Press $\square$ (■ on the remote).
Pause	Press $\square\square$ (■ on the remote). Press again to resume play.
Select a track	During play or pause, turn the jog dial clockwise (to go forward) or counterclockwise (to go back) and release it when you reach the desired track. (Or press $\blacktriangleright\blacktriangleright$ (to go forward) or $\blacktriangleleft\blacktriangleleft$ (to go back) on the remote.)
Find a point in a track	Press and hold down $\blacktriangleright\blacktriangleright$ or $\blacktriangleleft\blacktriangleleft$ (or $\blacktriangleright\blacktriangleright / \blacktriangleleft\blacktriangleleft$ on the remote) during play and release it at the desired point.
Select a CD in stop mode	Press a DISC 1~5 button (or D. SKIP on the remote).
Play only the CD you have selected	Press PLAY MODE repeatedly until "1 DISC" appears.
Play all CDs	Press PLAY MODE repeatedly until "ALL DISCS" appears.
Remove the CD	Press one of the CD 1~5 $\triangle$ buttons.
Change other CDs while playing a CD	Press one of the CD 1~5 $\triangle$ buttons to open the tray that contains the CD that you want to change. When you change the CD, press the same button to close the tray. While the tray is open, the DISC 1~5 button indicator for that tray flashes orange.
Adjust the volume	Turn VOLUME (or press VOLUME +/- on the remote).

### Tips

- Pressing  $\blacktriangleright$  when the power is off automatically turns the power on and starts CD playback if there is a CD in the tray (One Touch Play). When the system is in the Power Saving Mode, the One Touch Play function does not work.
- You can switch from another source to the CD player and start playing a CD just by pressing  $\blacktriangleright$  or the DISC 1~5 buttons (Automatic Source Selection).
- If there is no CD in the player, "CD NO DISC" appears in the display.
- When a disc tray holding a CD is selected (or playing), the DISC 1~5 button for that tray lights green.

### Note

Do not use force to close the disc tray, as this may cause CD player trouble. Always close the tray by pressing the appropriate CD 1~5  $\triangle$ .

## Recording a CD

### — CD Synchro Recording

The CD SYNC button lets you record from a CD to a tape easily. You can use TYPE I (normal) or TYPE II (CrO<sub>2</sub>) tapes. The recording level is adjusted automatically.

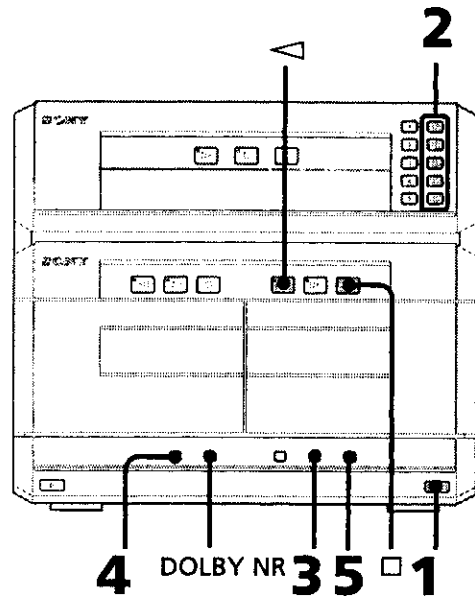

- 1 Press  $\triangle$  and insert a recordable tape into deck B.

With the side you want to record facing forward

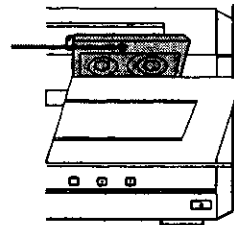

continued

## Recording a CD (continued)

- Press one of the CD 1~5  $\triangle$  buttons and place a CD.

Then press again to close the disc tray.

With the label side up. When you play a CD single, place it on the inner circle of the tray.

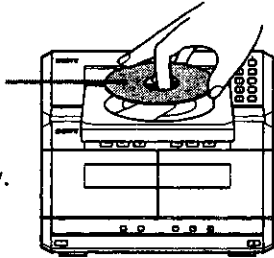

- Press CD SYNC.

Deck B stands by for recording and the CD player stands by for playback.  $\triangle$  (for front side) lights up.

- Press DIRECTION repeatedly to select  $\rightleftarrows$  to record on one side. Select  $\leftrightarrow$  (or RELAY) to record on both sides.

- Press REC PAUSE/START. Recording starts.

### To stop recording

Press  $\square$  on deck B or on the CD player.

### Tips

- If you want to record from the reverse side, press  $\triangleleft$  so that  $\triangleleft$  (for reverse side) lights up.
- When you record on both sides, be sure to start from the front side. If you start from the reverse side, recording stops at the end of the reverse side.
- When you want to reduce the hiss noise in low-level high-frequency signals, press DOLBY NR so that "DOLBY NR" appears after pressing CD SYNC.

### Notes

- You cannot listen to other sources while recording.
- Dolby NR is off and DIRECTION ( $\rightleftarrows$  or RELAY) is  $\leftrightarrow$  when the mains AC power supply is switched off.

## Listening to the radio

### — Preset Tuning

Preset radio stations in the tuner's memory first (see "Step 3: Presetting radio stations").

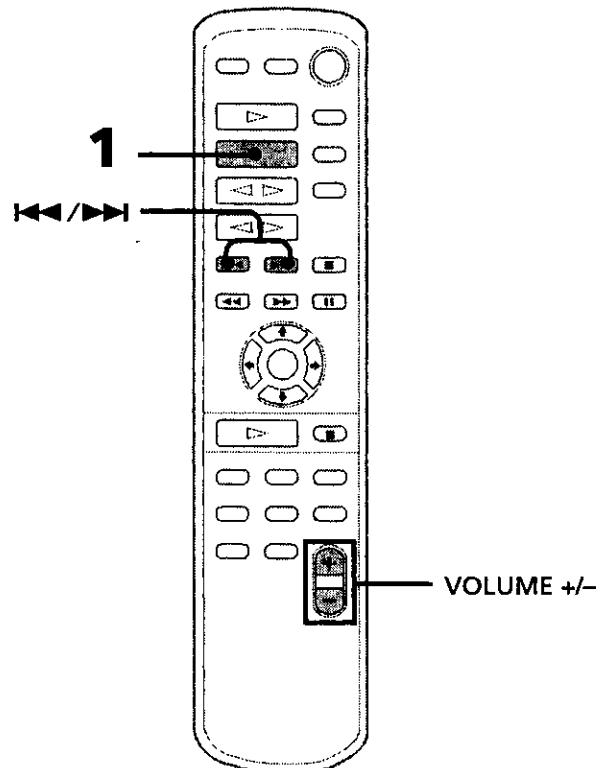
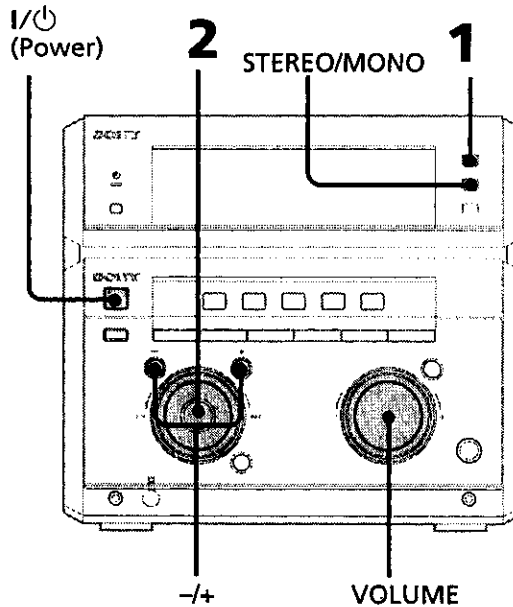

**1** Press TUNER BAND repeatedly until the band you want appears in the display.

The bands you can receive vary depending on the model you purchased. Be sure to check which bands you can receive.

Every time you press the button, the band changes as follows:

2 band model:

FM ↔ AM

3 band model:

FM → MW → SW



or

FM → AM → UKV\*



\* "STEREO PLUS" is displayed when you select UKV.

**2** Turn the jog dial (or press ◀◀ or ▶▶ on the remote) to tune in the desired preset station.

Turn counter-clockwise (or press ◀◀ on the remote) for lower preset numbers.



Turn clockwise (or press ▶▶ on the remote) for higher preset numbers.

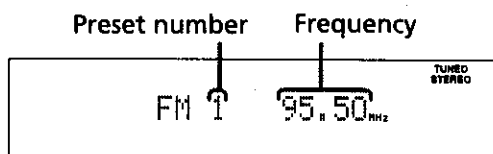

When only one station is preset, "ONE PRESET" appears in the display.

To	Do this
Turn off the radio	Press I/⏻ (power).
Adjust the volume	Turn VOLUME (or press VOLUME +/- on the remote).

### To listen to non-preset radio stations

Use manual or automatic tuning. For manual tuning, press - or + repeatedly. For automatic tuning, press and hold - or +.

#### Tips

- Pressing TUNER BAND when the power is off automatically turns the power on and tunes to the last received station (One Touch Play). When the system is in the Power Saving Mode, the One Touch Play function does not work.
- You can switch from another source to the radio just by pressing TUNER BAND (Automatic Source Selection).
- When an FM programme is noisy, press STEREO/MONO so that "MONO" appears in the display. There will be no stereo effect, but the reception will improve. Press the button again to restore the stereo effect.
- To improve broadcast reception, reorient the supplied antennas.

# Recording from the radio

You can record the radio programme on a tape by calling up a preset station. You can use TYPE I (normal) or TYPE II (CrO<sub>2</sub>) tapes. The recording level is automatically adjusted.

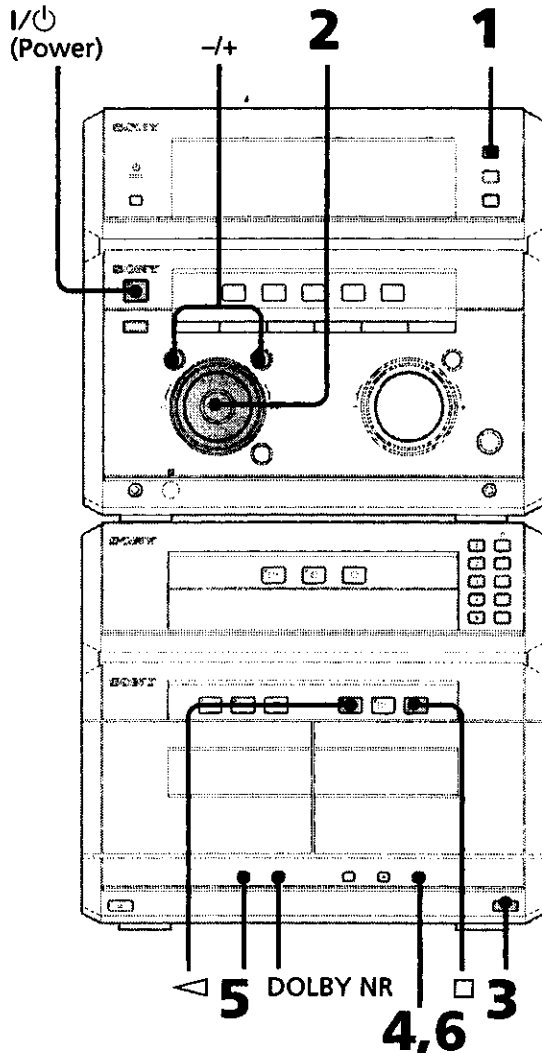

**1** Press TUNER BAND to select the band you want.

**2** Turn the jog dial to tune in a preset station.

Turn counter-clockwise for lower preset numbers.



Turn clockwise for higher preset numbers.

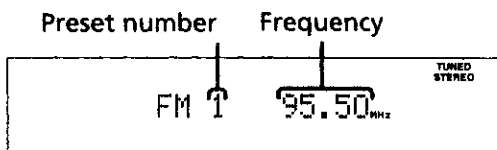

**3** Press and insert a recordable tape into deck B.

With the side you want to record facing forward

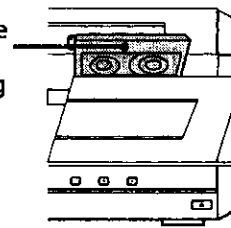

**4** Press REC PAUSE/START. Deck B stands by for recording.

**5** Press DIRECTION repeatedly to select to record on one side. Select (or RELAY) to record on both sides.

**6** Press REC PAUSE/START. Recording starts.

## To stop recording

Press on deck B.

## Tips

- If you want to record from the reverse side, press so that (for reverse side) lights up.
- When you record on both sides, be sure to start from the front side. If you start from the reverse side, recording stops at the end of the reverse side.
- To record non-preset stations, use - and + to tune in the desired station manually.
- When you want to reduce the hiss noise in low-level high-frequency signals, press DOLBY NR so that "DOLBY NR" lights up after pressing REC PAUSE/START in step 6.
- If noise is heard while recording from the radio, move the respective antenna to reduce the noise.

## Note

Dolby NR is off and DIRECTION ( or RELAY) is when the mains AC power supply is switched off.

# Playing a tape

You can use any type of tape, TYPE I (normal), TYPE II (CrO<sub>2</sub>) or TYPE IV (metal), since the deck automatically detects the tape type. You can also use the jog dial's AMS\* functions to quickly search for songs you want to hear. To select either deck A or B, press DECK A ◀▶ or DECK B ◀▶ (on the remote).

\* AMS (Automatic Music Sensor)

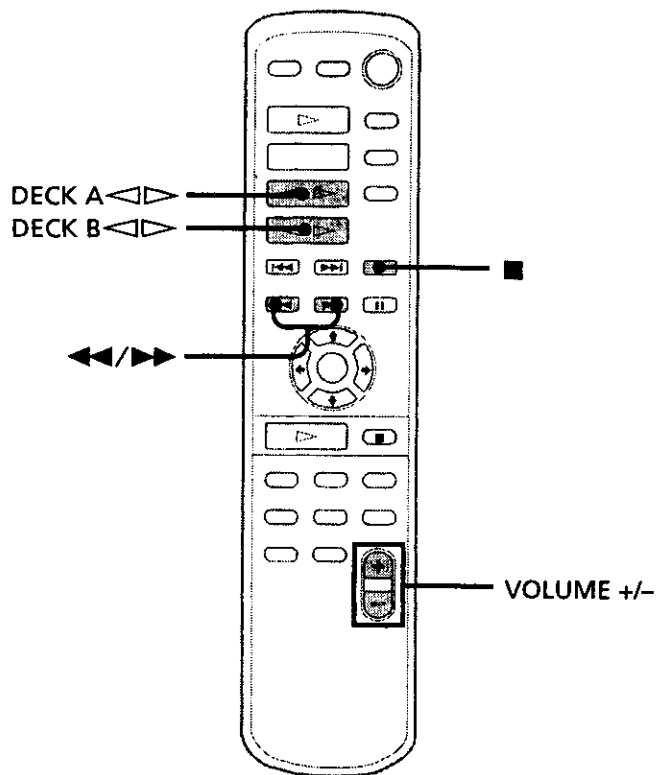
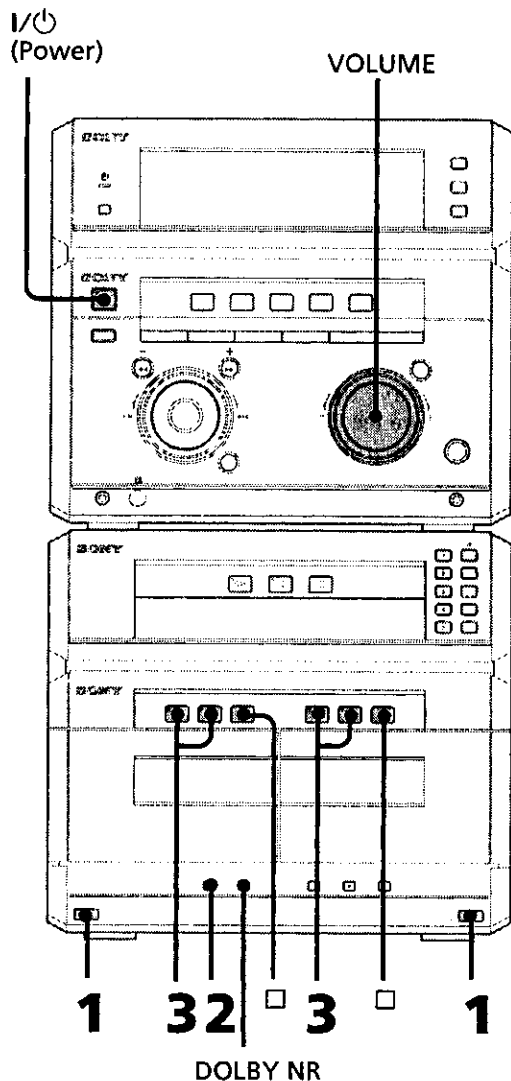

- 1 Press and insert a recorded tape into deck A or B.

With the side you want to play facing forward

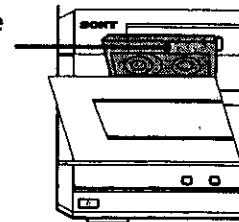

- 2 Press DIRECTION repeatedly to select to play one side. Select \*\* to play both sides. To play both decks in succession, select RELAY (relay play).\*\*\*

- 3 Press . Press to play the reverse side. The tape starts playing.

\*\* The deck stops automatically after repeating the sequence five times.

\*\*\*Relay play always follows the following sequence:

Deck A (front side), Deck A (reverse side), Deck B (front side), Deck B (reverse side).

continued

## Playing a tape (continued)

To	Do this
Stop play	Press □ (or ■ on the remote).
Fast-forward	Press ►► on the remote while playing the front side or ◀◀ while playing the reverse side.
Rewind	Press ◀◀ on the remote while playing the front side or ►► while playing the reverse side.
Remove the cassette	Press ⏏ .
Adjust the volume	Turn VOLUME (or press VOLUME +/- on the remote).

### Tips

- Pressing ▷ or ◁ when the power is off automatically turns the power on and starts tape playback if there is a tape in the deck (One Touch Play). When the system is in the Power Saving Mode, the One Touch Play function does not work.
- You can switch from another source to the tape deck just by pressing ▷ or ◁ (Automatic Source Selection).
- If the tape you want to play is recorded with DOLBY NR, you can reduce the noise by pressing DOLBY NR so that "DOLBY NR" lights up.
- When dubbing tapes originally recorded with Dolby NR, the dubbed tape is automatically played with Dolby NR.

## Searching for the beginning of a track (AMS\*)

During playback, turn the jog dial the same direction as the ◁ or ▷ indicator to go forward. Turn the opposite direction to go back. (Or press ◀◀ or ►► on the remote.)

The search direction, + (forward) or - (back), and number of songs being skipped (1~9) appear in the display.

Example: searching forward 2 songs

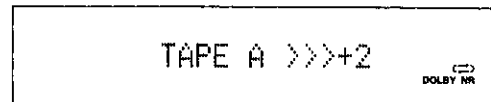

\* AMS (Automatic Music Sensor)

### Notes

- The AMS function may not operate correctly under the following circumstances:
  - When the unrecorded space between songs is less than 4 seconds long.
  - If completely different information is recorded on the left and right channels.
  - When there are continuous sections of extremely low level or low frequency sound (like those of a baritone sax).
  - When the unit is placed near a television. (In this case, we recommend moving the unit farther away from the television or turning off the television.)
- Dolby NR is off and DIRECTION (↔ or RELAY) is ↔ when the mains AC power supply is switched off.



# Recording from a tape

## — High-speed Dubbing

You can use TYPE I (normal) or TYPE II (CrO<sub>2</sub>) tapes. The recording level is automatically adjusted.

I/⏻  
(Power)

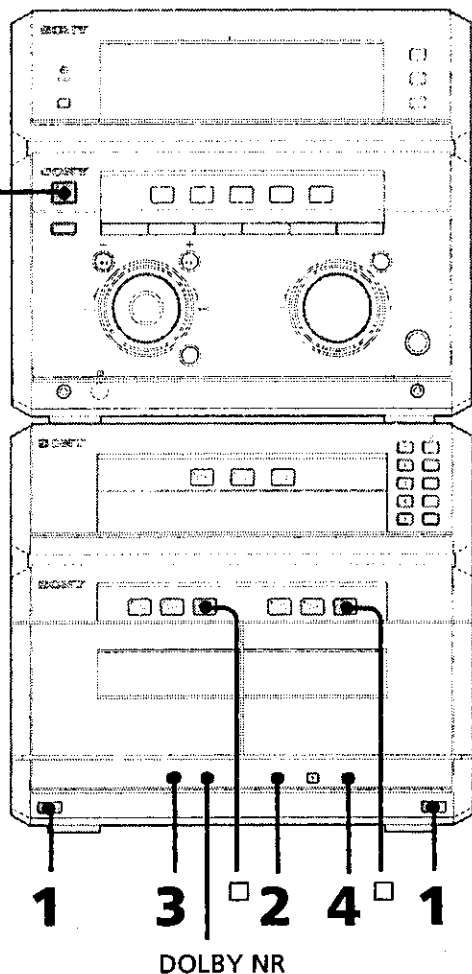

- 1 Press and insert a recorded tape in deck A and a recordable tape in deck B.

With the side you want to play/record facing forward

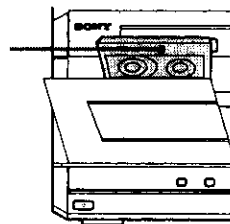

- 2 Press HI DUB.  
Deck B stands by for recording.
- 3 Press DIRECTION repeatedly to select to record on one side. Select (or RELAY) to record on both sides.
- 4 Press REC PAUSE/START.  
Dubbing starts.

### To stop dubbing

Press on deck A or B.

### Tips

- When you dub on both sides, start recording from the front side. If you record from the reverse side, recording stops at the end of the reverse side.
- If you set DIRECTION to when the tapes you use have different lengths, the tape in each deck reverses independently. If you select RELAY, the tapes on both decks reverse together.
- You don't have to set DOLBY NR, since the tape in deck B is automatically recorded in the same state as the tape in deck A.
- Dolby NR is off and DIRECTION ( or RELAY) is when the mains AC power supply is switched off.

# The CD Player

## Using the CD display

You can check the remaining time of the current track or that of the CD.

When a CD TEXT disc is loaded, you can check the information stored on the disc, such as the disc titles or artist names. When the unit detects CD TEXT discs, the "CD TEXT" indication appears in the display.

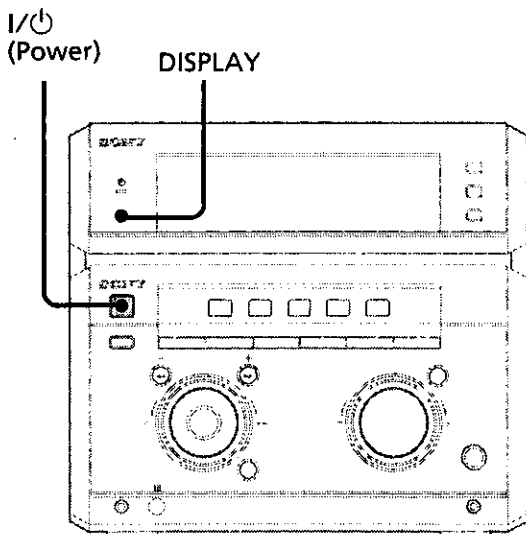

→ Press DISPLAY.

Each time you press the button during normal playback or in the stop mode, the display changes as follows:

### During normal playback

- Playing time on the current track
- ↓
- Remaining time on the current track
- ↓
- Remaining time on current CD (1 DISC mode) or "--:--" display (ALL DISCS mode)
- ↓
- Title name of the current track\*
- ↓
- Clock display (for eight seconds)
- ↓
- Effect (P FILE) name or "EFFECT ON (OFF)"

### In the stop mode

- Title name of the CD\*
- ↓
- Artist information\*
- ↓
- Total number of tracks and total playing time\*\*
- ↓
- Clock display (for eight seconds)
- ↓
- Effect (P FILE) name or "EFFECT ON (OFF)"

\* With CD TEXT discs only (certain characters cannot be displayed). When the disc contains more than 20 tracks, CD TEXT is not displayed from track 21 on.

\*\*When programme mode is selected, the track number of the last track in the programme and the total number tracks in the programme (number of steps) are displayed.

© 1997 Sony Electronics Inc. All rights reserved. Sony, the Sony logo, and CD are registered trademarks of Sony Electronics Inc. in the U.S. and other countries. All other trademarks are the property of their respective owners.

### Tip

Pressing and holding DISPLAY for 2 seconds or more switches the spectrum analyzer ON/OFF.

## Playing the CD tracks repeatedly

### — Repeat Play

This function lets you repeat a single CD or all CDs in normal play, shuffle play and programme play.

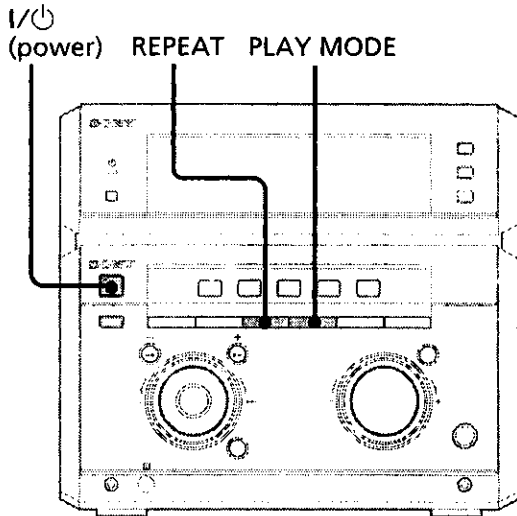

- ➔ Press REPEAT during playback until "REPEAT" appears in the display. Repeat Play starts. Do the following procedure to change the repeat mode.

To repeat	Press
All the tracks on the current CD	PLAY MODE repeatedly until "1 DISC" appears in the display.
All the tracks on all CDs up to five times	PLAY MODE repeatedly until "ALL DISCS" appears in the display.
Only one track	REPEAT repeatedly until "REPEAT 1" appears in the display while playing the track you want to repeat.

### To cancel Repeat Play

Press REPEAT so that "REPEAT" or "REPEAT 1" disappears from the display.

### Note

ALL DISCS repeat cannot be used during shuffle play.

## Playing the CD tracks in random order

### — Shuffle Play

You can play all the tracks on one CD or all CDs in random order.

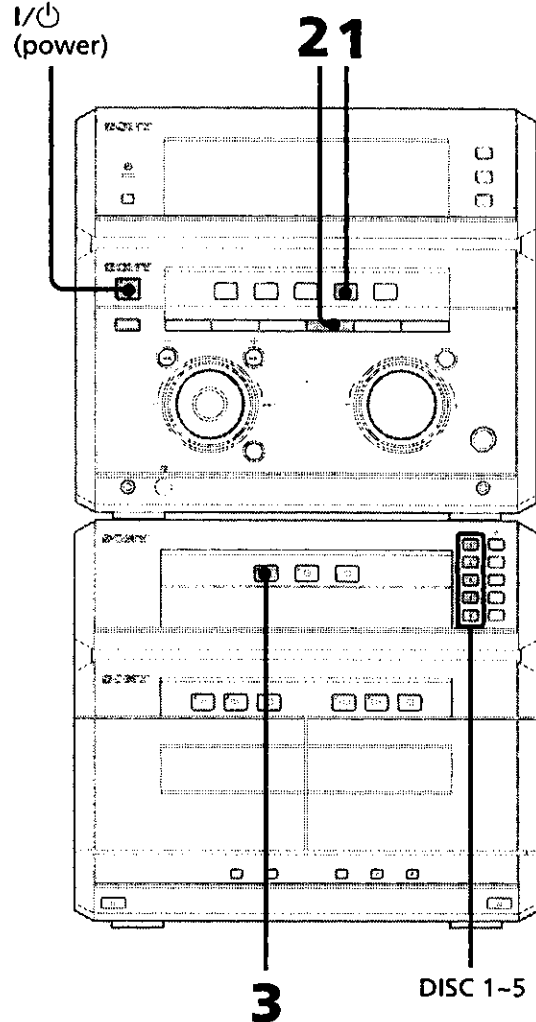

- 1 Press CD, then place a CD.
- 2 Press PLAY MODE repeatedly until "1 DISC SHUFFLE" or "ALL DISCS SHUFFLE" appears in the display. "ALL DISCS" shuffles all the CDs in the player. "1 DISC" shuffles the CD whose DISC indicator is green.

- 3 Press . All the tracks play in random order.

continued

## Playing the CD tracks in random order (continued)

### To cancel Shuffle Play

Press PLAY MODE repeatedly until "SHUFFLE" or "PROGRAM" disappears from the display.

### To select a desired CD

Press DISC 1~5.

### Tips

- You can start Shuffle Play during normal play by pressing PLAY MODE repeatedly to select "SHUFFLE".
- To skip a track, turn the jog dial clockwise (or press ►► on the remote).

## Programming the CD tracks

### — Programme Play

You can make a programme of up to 32 tracks from all the CDs in the order you want them to be played.

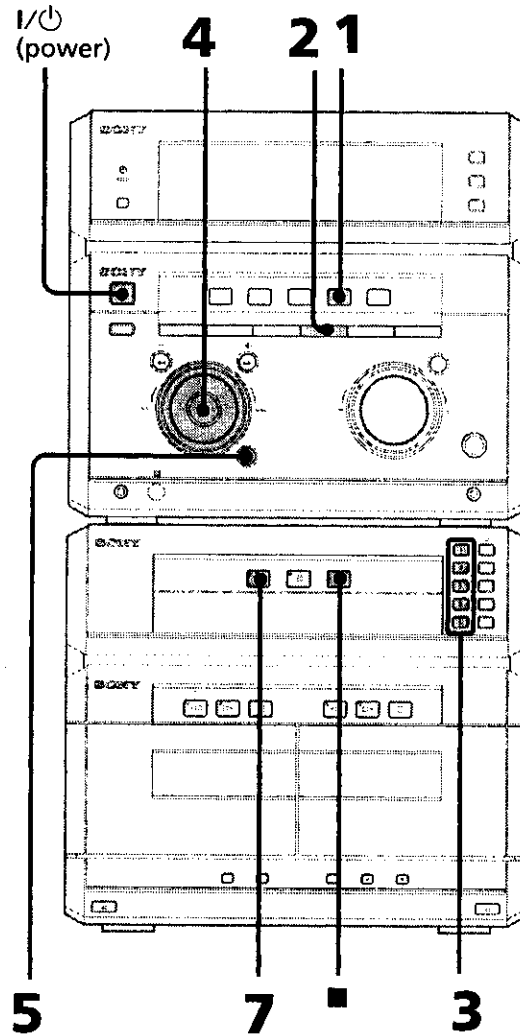

- 1** Press CD, then place a CD.
- 2** Press PLAY MODE repeatedly until "PROGRAM" appears in the display.
- 3** Press one of the DISC 1~5 buttons to select a CD.  
To programme all the tracks on a CD at once, proceed to step 5.
- 4** Turn the jog dial until the desired track appears in the display.

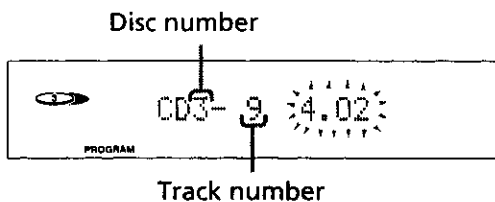

- 5** Press ENTER.  
The track is programmed. The last programmed track and the total programmed track number appear, followed by the total playing time.

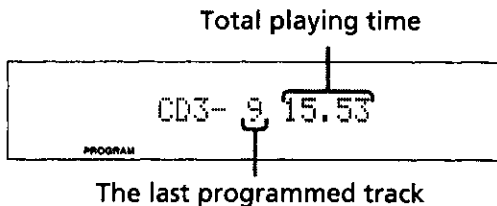

- 6** To programme additional tracks, repeat steps 3 to 5.  
Skip step 3 to select tracks from the same disc.
- 7** Press ▷.  
All the tracks play in the order you selected.

### To cancel Programme Play

Press PLAY MODE repeatedly until "PROGRAM" or "SHUFFLE" disappears from the display.

To	Press
Check the programme	CHECK on the remote repeatedly. After the last track, "CHECK END" appears.
Clear a track from the end	CLEAR on the remote in stop mode.
Clear a specific track	CHECK on the remote repeatedly until the number of the track to be erased lights up, then press CLEAR.
Add a track to the programme	1 Select the disc tray with a DISC 1~5 button. 2 Select the track by turning the jog dial. 3 Press ENTER.
Clear the entire programme	<input type="checkbox"/> once in stop mode or twice while playing.

### Tips

- The programme you made remains in the CD player even after it has been played back. Press ▷ to play the same programme again.
- If "--:" appears instead of the total playing time during programming, this means:
  - you have programmed a track number which exceeds 20
  - the total playing time has exceeded 100 minutes.

## The Tape Deck

### Recording on a tape manually

You can record from CD, tape, or radio as you like. For example, you can record just the songs you want or record from the middle of the tape. The recording level is adjusted automatically.

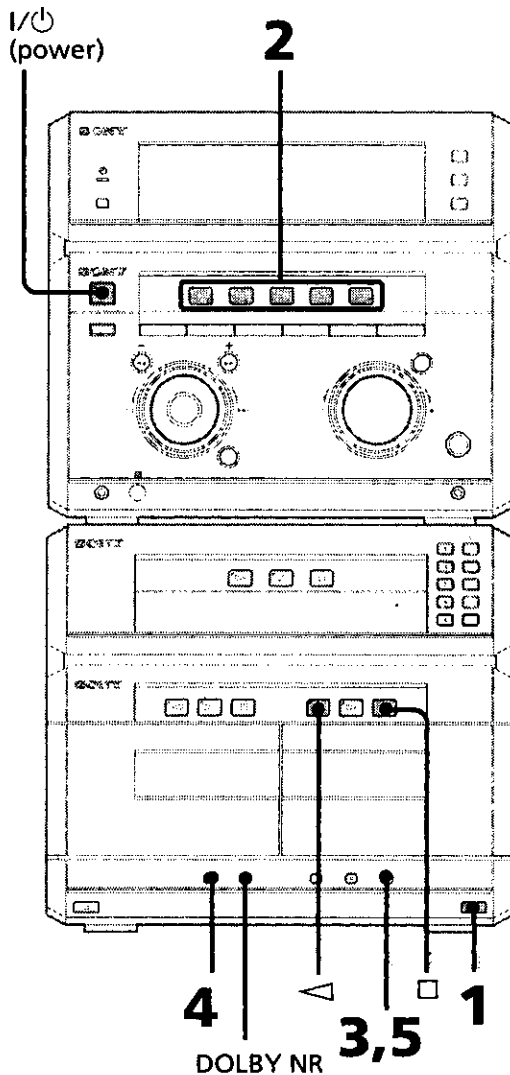

- 1** Insert a recordable tape into deck B.
- 2** Press one of the function buttons you want to record (e.g., CD).
- 3** Press REC PAUSE/START.  
Deck B stands by for recording.  $\blacktriangleright$  (for front side) lights up.

- 4** Press DIRECTION repeatedly to select  $\blacktriangleleft$  to record on one side. Select  $\blacktriangleleft\blacktriangleright$  (or RELAY) to record on both sides.
- 5** Press REC PAUSE/START.  
Recording starts.
- 6** Start playing the source to be recorded.

To	Press
Stop recording	$\square$ on the deck B
Pause recording	REC PAUSE/START

#### Tips

- If you want to record from the reverse side, press  $\blacktriangleleft$  so that  $\blacktriangleleft$  (for reverse side) lights up.
- When you want to reduce the hiss noise in low-level high-frequency signals, press DOLBY NR so that "DOLBY NR" lights up after pressing REC PAUSE/START in step 3.
- When recording from a CD, you can use the jog dial to select tracks during recording pause mode (after pressing REC PAUSE/START in step 3 and before pressing again in step 5).

#### Note

Dolby NR is off and DIRECTION ( $\blacktriangleleft\blacktriangleright$  or RELAY) is  $\blacktriangleleft\blacktriangleright$  when the mains AC power supply is switched off.

# Recording a CD by specifying track order

## — Programme Edit

You can record tracks from all the CDs in the order you want. When programming, make sure the playing times for each side do not exceed the length of one side of the tape.

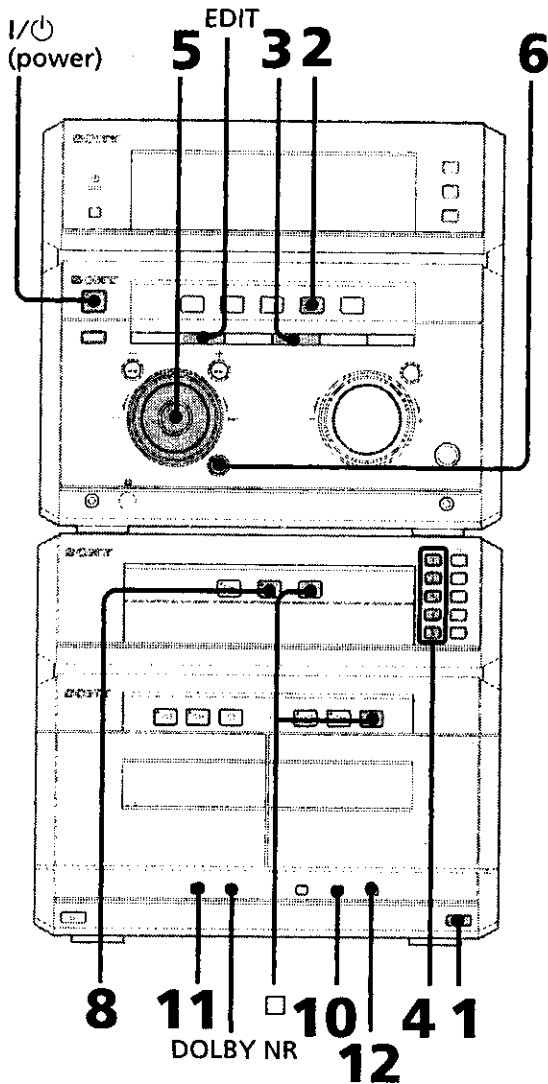

**1** Place a CD and insert a recordable tape into deck B.

**2** Press CD.

**3** Press PLAY MODE repeatedly until "PROGRAM" appears in the display.

**4** Press one of the DISC 1~5 buttons to select a CD.

**5** Turn the jog dial until the desired track appears in the display.

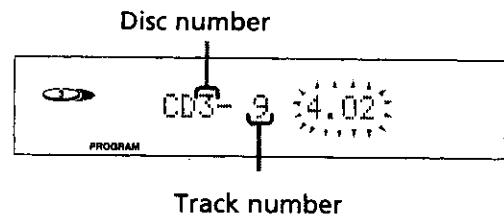

**6** Press ENTER. The track is programmed. The last programmed track and the total programmed track number appear, followed by the total playing time.

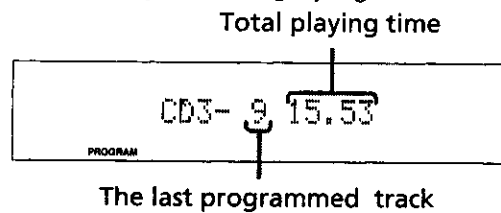

**7** To programme additional tracks to be recorded on side A, repeat steps 4 to 6. Skip step 4 to select tracks from the same disc.

continued

## Recording a CD by specifying track order (continued)

- 8** Press **00** (**||** on the remote) to insert a pause at the end of side A.  
"P" appears in the display and the total playing time resets to "0.00" in the display.
- 9** Repeat steps 5 and 6 for tracks from the same disc or steps 4 to 6 for tracks from another disc to programme the remaining tracks to be recorded on side B.
- 10** Press **CD SYNC**.  
Deck B stands by for recording and the CD player stands by for playback. **▷** (for front side) lights up.
- 11** Press **DIRECTION** repeatedly to select **⇌** to record on one side.  
Select **↔** (or **RELAY**) to record on both sides.
- 12** Press **REC PAUSE/START**.  
Recording starts.

### To stop recording

Press **□** on the deck B or on the CD player.

### To check the order

Press **CHECK** on the remote repeatedly. After the last track, "CHECK END" appears.

### To cancel Programme Edit

Press **PLAY MODE** repeatedly until "PROGRAM" or "SHUFFLE" disappears from the display.

### Tip

When you want to reduce the hiss noise in low-level high-frequency signals, press **DOLBY NR** so that "DOLBY NR" appears after pressing **CD SYNC**.

## Selecting tape length automatically

### — Tape Select Edit

You can check the most suitable tape length for recording a CD. Note that you cannot use Tape Select Edit for discs containing more than 20 tracks.

- 1** Insert a CD.
- 2** Press **CD**.
- 3** Press **EDIT** (**EDIT/PTY** on European model) once so that "EDIT" flashes.  
The required tape length for the currently selected CD appears, followed by the total playing time for side A and side B respectively.

### Notes

- You cannot use this function after programming. In order to use this function, you must first cancel the programme by pressing **PLAY MODE** repeatedly until "PROGRAM" or "SHUFFLE" disappears from the display.
- This function does not work when the total playing time of the CD is shorter than 1 minute.
- Dolby NR is off and **DIRECTION** (**⇌** or **RELAY**) is **↔** when the mains AC power supply is switched off.



# Sound Adjustment

## Adjusting the sound

You can reinforce the bass, create a more powerful sound, and listen with headphones.

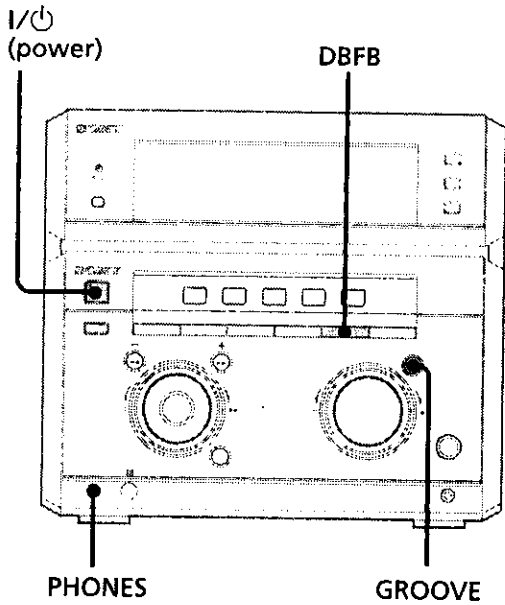

### To reinforce bass (DBFB)

Press DBFB\*.

Every time you press the button, the display changes as follows:

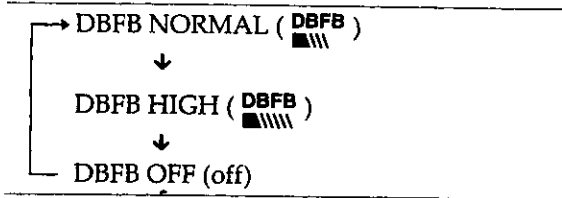

\* DBFB = Dynamic Bass Feedback

### For a powerful sound (GROOVE)

Press GROOVE. The volume switches to power mode, DBFB is automatically set to full strength, the equalizer curve changes, and GROOVE button lights up. Press GROOVE again to return to the previous volume.

#### Notes

- With some songs, the music will sound distorted when you use the DBFB system with the sound effect if the bass is too strong. Set the DBFB to "DBFB" or "OFF", or cancel the sound effect (page 26).
- Cancelling GROOVE sets DBFB to "DBFB" and flattens the equalizer curve. To cancel the DBFB level, press DBFB until the indication disappears.

### To listen through the headphones

Connect the headphones to PHONES jack. No sound will come from the speakers.

#### Note

If you have connected a super woofer, please note that sound comes from the super woofer even when the headphones are connected. Turn off the power of the super woofer when using headphones.

# Selecting the audio emphasis

The audio emphasis menu lets you select the sound characteristic according to the sound you are listening to.

Besides, you can also enjoy audio emphasis using the synchronized equalizer function. When using this function, the system switches the equalizer according to the genre automatically.

## Selecting the effect from the music menu

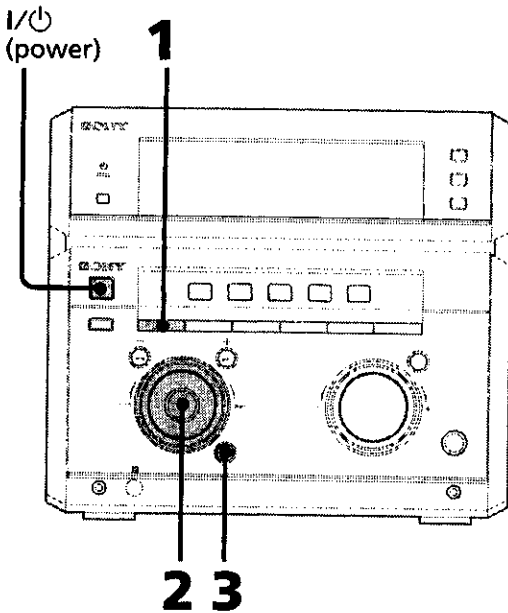

- 1** Press FILE SELECT.  
The last effect chosen appears in the display.
- 2** Use the jog dial to select the preset you desire.  
The preset name appears in the display. See the chart "Music menu options".
- 3** Press ENTER.

### To cancel the effect

Press EFFECT on the remote repeatedly so that "EFFECT OFF" appears in the display.

### Music menu options

"SUR" appears if you select an effect with surround effects.

Effect	For
ROCK POP SOUL HOUSE R&B	Standard music sources
ACTION ROMANCE SF DRAMA SPORTS	Soundtracks and special listening situations
SHOOTING RACING RPG BATTLE ADVENTURE	Video games
P FILE 1~5	Personal file*

\* The personal file function lets you store your own effects (see "Making a personal audio emphasis file" on page 29).

### Tip

When using the remote, pressing  $\blacktriangle/\blacktriangledown$  displays the last effect chosen and you can select a new effect in the music menu.

## Changing the brightness of the display

You can enjoy changing the brightness of the display while listening to the music.

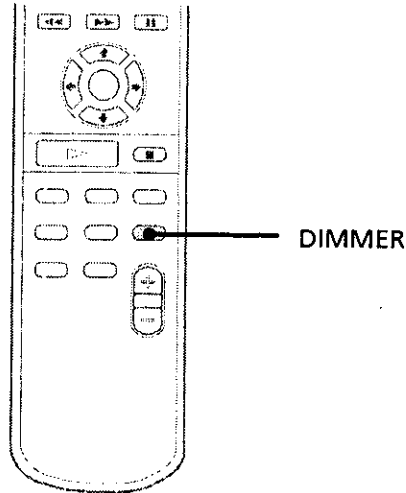

- ➔ Press DIMMER on the remote.  
Every time you press the button, the display changes as follows:

DIMMER ON  
↕  
DIMMER OFF

## Selecting surround effects

You can enjoy surround effects.

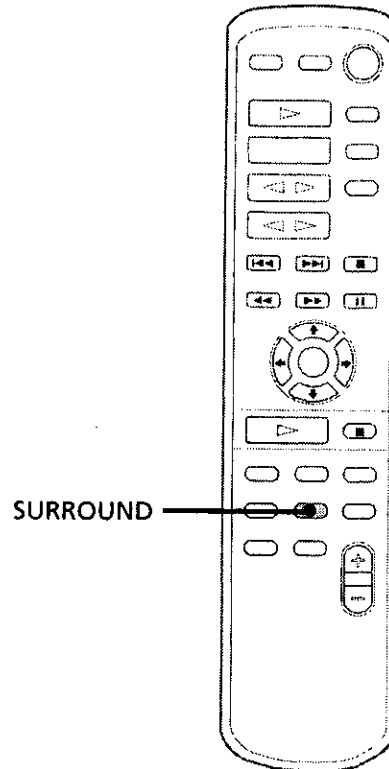

- ➔ Press SURROUND repeatedly to select the surround effect you desire.

Every time you press the button, the display changes as follows:

SURROUND ON (SUR)  
↕  
SURROUND OFF (off)

### Tip

If you want to memorize the effect, store it into a personal file (see "Making a personal audio emphasis file" on page 29).

### Note

When you choose other sound effects, the surround effects will be canceled.

# Adjusting the graphic equalizer

You can adjust the sound by raising or lowering the levels of specific frequency ranges.

Before operation, first select the audio emphasis you want for your basic sound.

## Note

If you choose another menu of audio emphasis (other than "EFFECT OFF"), the adjusted sound effect is lost. To retain the adjusted sound effect for future use, store it in a personal file. (See "Making a personal audio emphasis file" on page 29.)

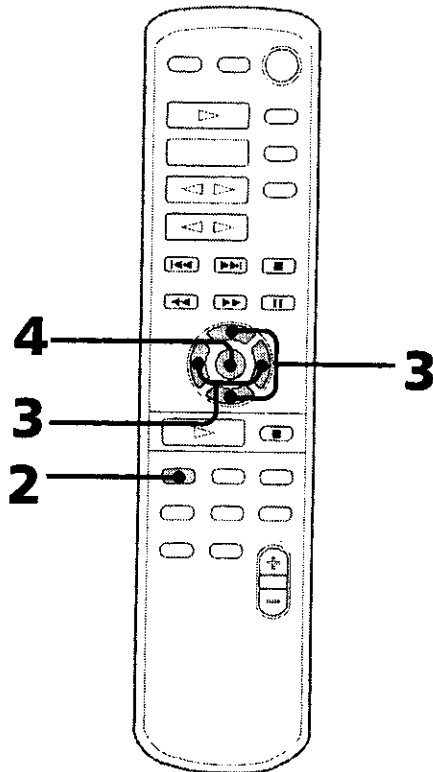

**1** Select the audio emphasis you want for your basic sound (see "Selecting the audio emphasis" on page 26).

**2** Press GEQ.

**3** Press ◀ or ▶ to select frequency, press ▲ or ▼ for the desired frequency band to adjust level.

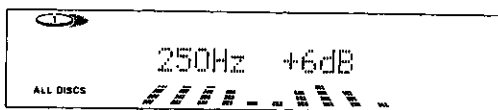

**4** Press ENTER.

---

# Making a personal audio emphasis file

## — Personal file

You can create a personal file of audio patterns (surround effect and graphic equalizer) and store them in the memory of the unit. Later call up an audio pattern to play a favorite tape, CD, or radio programme. Create up to five audio files.

Before operation, first select the audio emphasis you want for your basic sound.

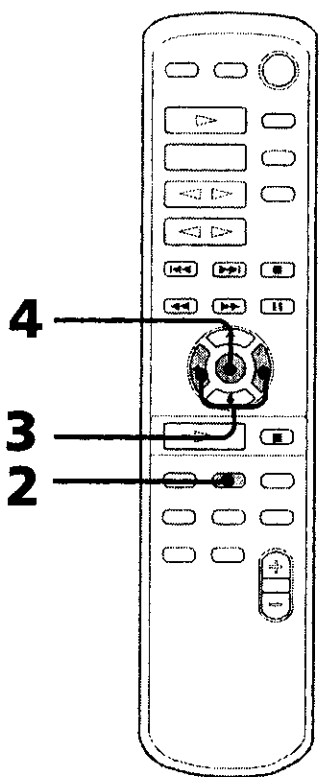

---

**1** Obtain the sound effect you want by using the graphic equalizer and surround effect. (See "Adjusting the graphic equalizer" on page 28, "Selecting surround effects" on page 27 and "Selecting the audio emphasis" on page 26.)

---

**2** Press P FILE.

The personal file number flashes in the display.



---

**3** Press ◀ or ▶ to select the file number (P FILE) where you want to store the sound effect.

---

**4** Press ENTER.

The adjusted sound effects are stored under the selected file number. The settings previously stored at this memory location are erased and replaced by the new settings.

---

## Other Features

# Using the Radio Data System (RDS)

(For European model only)

### What is the Radio Data System?

Radio Data System (RDS) is a broadcasting service that allows radio stations to send additional information along with the regular programme signal. This tuner offers convenient RDS features like station name display and location of stations by programme type. RDS is available only on FM stations.\*

### Note

RDS may not work properly if the station you are tuned to is not transmitting the RDS signal properly or if the signal strength is weak.

\* Not all FM stations provide RDS service, nor do they provide the same type of services. If you are not familiar with the RDS system, check with your local radio stations for details on RDS services in your area.

## Receiving RDS broadcasts

➔ Simply select a station from the FM band.

When you tune in a station that provides RDS services, the station name appears in the display.

### To check the RDS information

Each time you press DISPLAY, the display changes as follows:

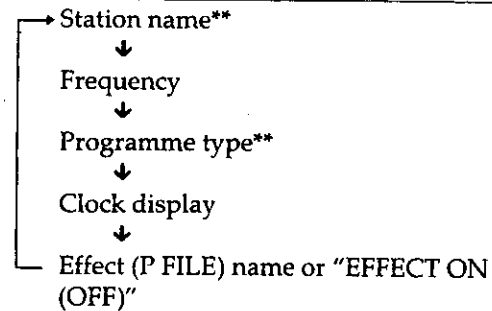

\*\*If the RDS broadcast is not received, the station name and programme type may not appear in the display.

### Tip

Pressing and holding DISPLAY for 2 seconds or more switches the spectrum analyzer ON/OFF.

## Locating a station by programme type (PTY)

You can locate a station you want by selecting a programme type. The unit tunes in the type of programmes currently being broadcast from the RDS stations stored in the tuner's preset memory.

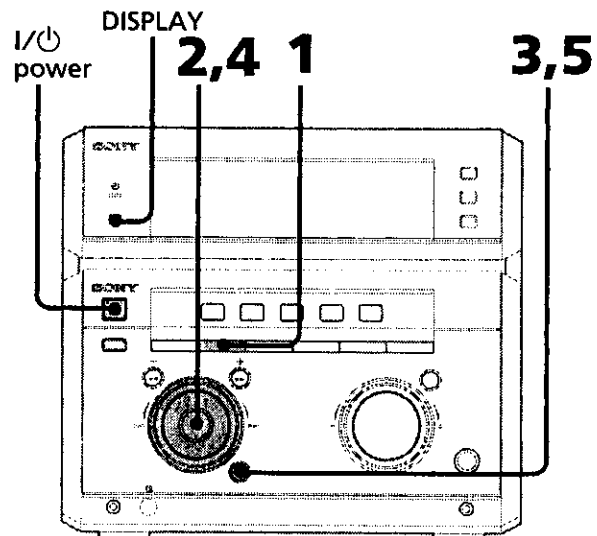

---

**1** Press EDIT/PTY while listening to the radio.

---

**2** Turn jog dial to select the programme type you want. See the "List of programme types" section below.

---

**3** Press ENTER.  
The unit starts searching the preset RDS stations ("SEARCH" and the selected programme type are shown alternately in the display).  
When the tuner receives a programme, the preset station number flashes.

---

**4** Turn jog dial to display the preset station number you desire.

---

**5** Press ENTER while the preset station number is flashing.

---

### To cancel PTY search

Press EDIT/PTY again.

### List of programme types (PTY)

---

#### NEWS

News programmes.

---

#### AFFAIRS

Topical programmes that expand on current news.

---

#### INFORMATION

Programmes about consumer affairs, medical advice.

---

#### SPORT

Sports programmes.

---

#### EDUCATION

Educational programmes, such as "how-to" programmes and advice.

---

#### DRAMA

Radio plays and serials.

---

#### CULTURE

Programmes about national or regional culture, language, and social concerns.

---

#### SCIENCE

Programmes about the natural sciences.

---

#### VARIED

Programmes containing celebrity interviews, panel games, and comedy.

---

#### POP

Popular music programmes.

---

#### ROCK

Rock music programmes.

---

#### EASY MUSIC

Easy listening (middle of the road music).

---

#### L. CLASSICAL

Classical music, such as instrumental, vocal, and choral works.

---

#### S. CLASSICAL

Performances of major orchestras, chamber music, opera, etc.

---

#### OTHER MUSIC

Music, such as rhythm and blues and reggae.

---

#### WEATHER

Weather information.

---

#### FINANCE

Stock market reports and trading, etc.

---

#### CHILDREN

Programmes for young.

---

#### SOCIAL

Programmes about people and the things that affect them.

---

#### RELIGION

Programmes of religious contents.

---

#### PHONE IN

Programmes where members of the public express their views by phone or in a public forum.

---

#### TRAVEL

Programmes about travel. Not for announcements that are located TP/TA.

---

#### LEISURE

Programmes on recreational activities such as gardening, fishing, cooking, etc.

## Using the Radio Data System (RDS) (continued)

### JAZZ

Jazz programmes.

### COUNTRY

Country music programmes.

### NATION

Programmes featuring the popular music of the country or region.

### OLDIES

Programmes featuring oldies music.

### FOLK

Folk Music Programmes.

### DOCUMENTARY

Investigative features.

### ALARM TEST

Test signal for emergency broadcasts.

### ALARM-ALARM

Emergency broadcasts.

### NONE

Any programming not defined above.

### Notes

"NO PTY" appears when the programme type you selected is not currently being broadcast.

## Falling asleep to music

### — Sleep Timer

You can let the system turn off at the preset time, so you can sleep to the music. You can preset the time to be turned off by 10 minutes.

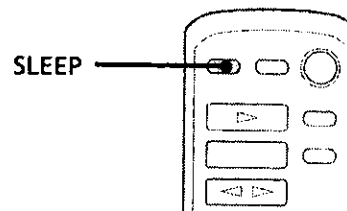

### ➔ Press SLEEP on the remote.

Every time you press the button, the minute display (the turn-off time) changes as follows:

AUTO → 90min → 80min → 70min  
→ ... → 10min → OFF → AUTO ...

### When you choose "AUTO"

The power turns off when the current CD or tape finishes playback (for up to 100 minutes).

### To check the remaining time

Press SLEEP on the remote once.

### To change the time to turn off

Select the time you want by pressing SLEEP on the remote.

### To cancel the Sleep Timer function

Press SLEEP on the remote repeatedly until "SLEEP OFF" appears.



# Waking up to music

## — Daily Timer

You can wake up to music at a preset time every day. Make sure you have set the clock (see "Step 2: Setting the time").

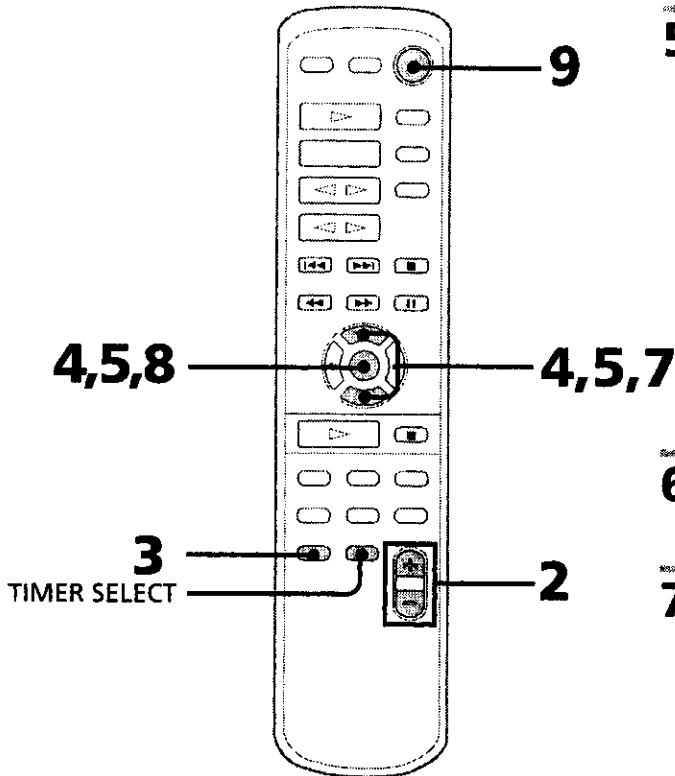

**1** Prepare the music source you want to play.

- CD: Insert a CD. To start from a specific track, make a programme (see "Programming the CD tracks").
- Tape: Insert a tape with the side you want to play facing forward.
- Radio: Tune in the preset station you want (see "Step 3: Presetting radio stations").

**2** Adjust the volume.

**3** Press CLOCK/TIMER.  
"SET (DAILY 1)" appears.

**4** Press  $\uparrow$  or  $\downarrow$  to select DAILY 1 or 2, then press ENTER.  
"ON" appears and the hour digits flash in the display.



**5** Set the time to start playback.  
Press  $\uparrow$  or  $\downarrow$  to set the hour, then press ENTER.  
The minute indication starts flashing.

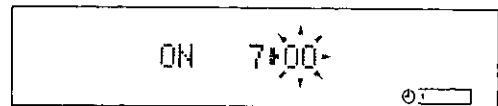

Press  $\uparrow$  or  $\downarrow$  to set the minute, then press ENTER.  
The hour indication flashes again.

**6** Set the time to stop playback following the above procedure.

**7** Press  $\uparrow$  or  $\downarrow$  until the music source you want appears.  
The indications change as follows:



**8** Press ENTER.  
The type of timer (DAILY 1 or DAILY 2), appears followed by the start time, stop time and the music source, then the original display appears.

**9** Turn off the power.

### To check the setting

Press TIMER SELECT and press  $\uparrow$  or  $\downarrow$  to select the respective mode (DAILY 1 or DAILY 2), then press ENTER. To change the setting, start over from step 1.

### To cancel the timer operation

Press TIMER SELECT and press  $\uparrow$  or  $\downarrow$  to select "TIMER OFF", then press ENTER.

### Tip

The power turns on 15 seconds before the preset time.

# Timer-recording radio programmes

To timer-record, you must preset the radio station (see "Step 3: Presetting radio stations") and set the clock (see "Step 2: Setting the time") beforehand.

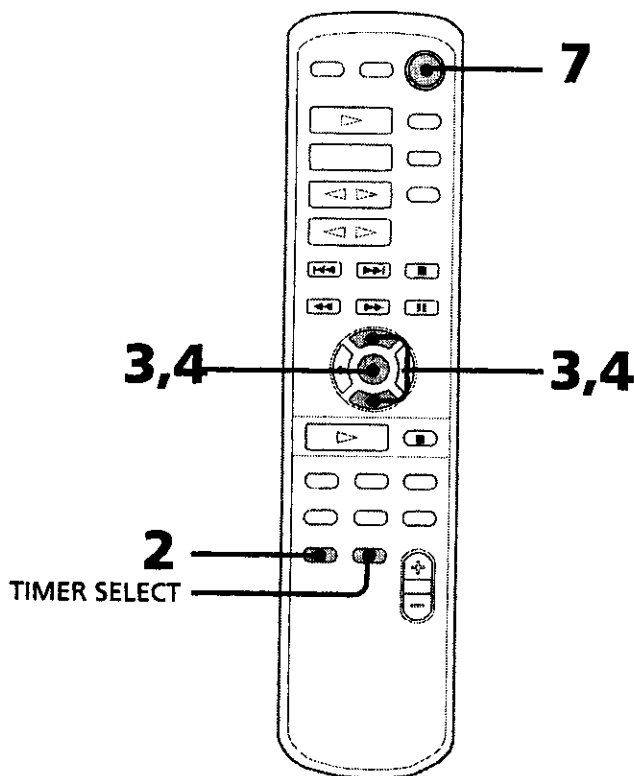

- 1** Tune in the preset radio station (see "Listening to the radio" on page 12).
- 2** Press CLOCK/TIMER.  
"SET (DAILY 1)" appears.
- 3** Press ↑ or ↓ to select "REC", then press ENTER.  
"ON" appears and the hour digits flash in the display.

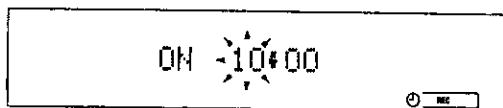

- 4** Set the time to start recording.  
Press ↑ or ↓ to set the hour, then press ENTER.  
The minute indication starts flashing.

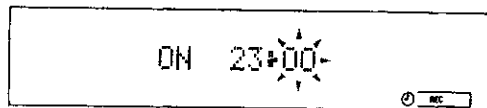

- Press ↑ or ↓ to set the minute, then press ENTER.  
The hour indication flashes again.

- 5** Set the time to stop recording following the above procedure.  
The start time appears, followed by the stop time, the recording source and the radio station, then the original display appears.
- 6** Insert a recordable tape into deck B.
- 7** Turn off the power.  
When the recording starts, the volume level is set to the minimum.

## To check the setting

Press TIMER SELECT and press ↑ or ↓ to select "REC", then press ENTER. To change the setting, start over from step 1.

## To cancel the timer operation

Press TIMER SELECT and press ↑ or ↓ to select "TIMER OFF", then press ENTER.

## Note

If the power is on at the preset time, the recording will not be made.

# Optional components

## Connecting audio components

Select one of the following connections, depending on the equipment to be connected and method of connecting. Refer to the instructions of each component.

## Connecting an MD deck for digital recording

You can record from CD into the MD deck digitally by connecting an optical cable.

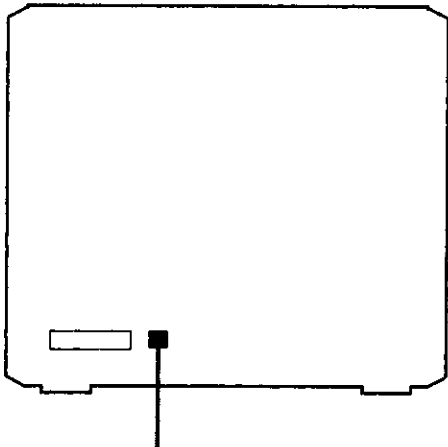

To the DIGITAL IN jack of the MD deck



## Connecting an MD deck for analog recording

Make sure to match the color of the plugs and the connectors. To listen to the sound of the connected MD deck, press MD.

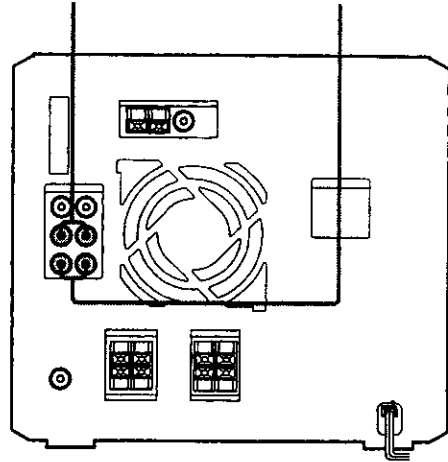
To the audio output of the MD deck      To the audio input of the MD deck



### Tip

When you connect a Sony MD deck, you can use the MD  and  buttons on this unit's remote to perform play and stop operations.

continued

## Connecting audio components (continued)

### Connecting a super woofer speaker

You can connect an optional super woofer speaker.

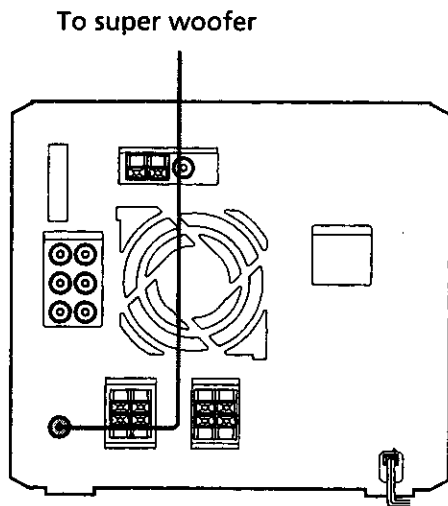

---

## Connecting a VCR

Make sure to match the color of the plugs and the connectors. To listen to the sound of the connected VCR, press VIDEO. Refer to the instructions of each component.

To the audio output of the VCR

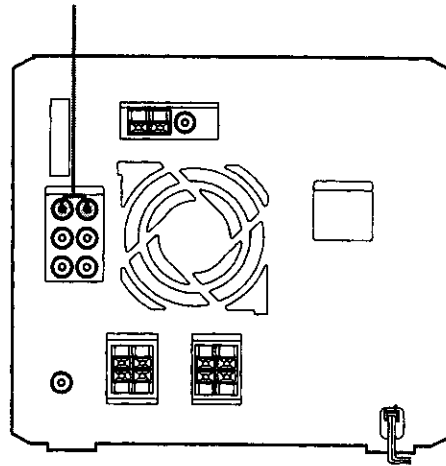

### Connecting a microphone

You can connect an optional microphone to the MIC jack. Adjust the microphone volume by turning MIC LEVEL.

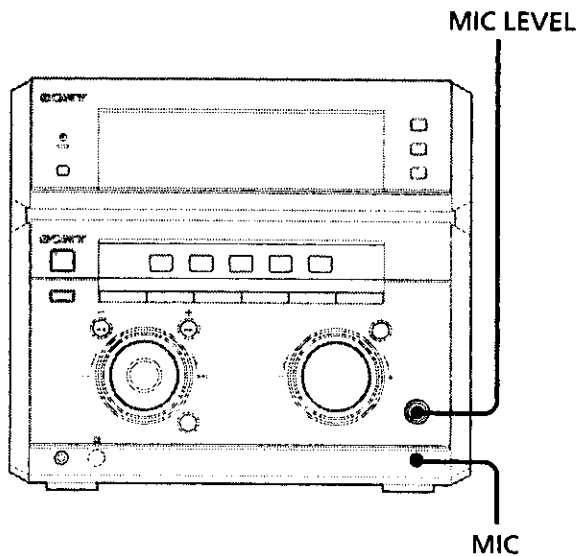

# Connecting external antennas

Connect the external antenna to improve the reception. Refer to the instructions of each component.

## FM antenna

Connect the optional FM external antenna. You can also use the TV antenna instead.

### Jack type ①

IEC standard socket connector (not supplied)

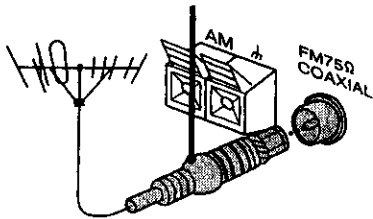

### Jack type ②

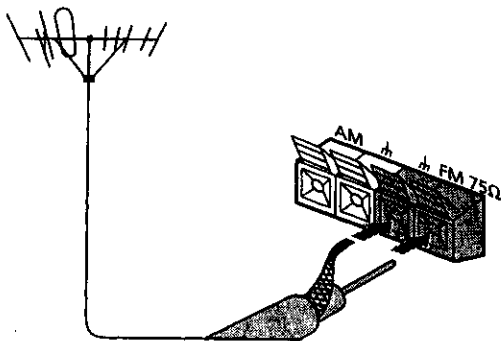

75-ohm coaxial cable (not supplied)

## AM antenna

Connect a 6- to 15- meter (20- to 50- feet) insulated wire to the AM antenna terminal. Leave the supplied AM loop antenna connected.

### Jack type ①

Insulated wire (not supplied)

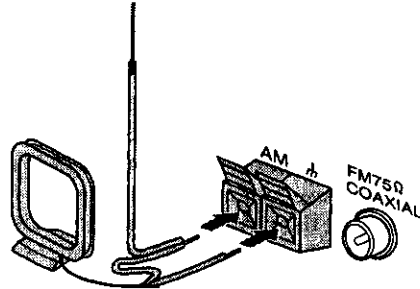

### Jack type ②

Insulated wire (not supplied)

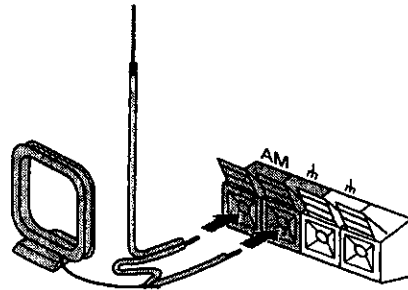

### Note

Set up the AM loop antenna as far as possible from the main unit.

## Additional Information

### Precautions

#### On operating voltage

Before operating the system, check that the operating voltage of your system is identical with the voltage of your local power supply.

#### On safety

- The unit is not disconnected from the AC power source (mains) as long as it is connected to the wall outlet, even if the unit itself has been turned off.
- Unplug the system from the wall outlet (mains) if it is not to be used for an extended period of time. To disconnect the cord (mains lead), pull it out by the plug. Never pull the cord itself.
- Should any solid object or liquid fall into the component, unplug the stereo system and have the component checked by qualified personnel before operating it any further.
- The AC power cord must be changed only at the qualified service shop.

#### On placement

- Place the stereo system in a location with adequate ventilation to prevent heat build-up in the stereo system.
- Do not place the unit in an inclined position.
- Do not place the unit in locations where it is:
  - Extremely hot or cold
  - Dusty or dirty
  - Very humid
  - Vibrating
  - Subject to direct sunlight.

#### On operation

- If the stereo system is brought directly from a cold to a warm location, or is placed in a very damp room, moisture may condense on the lens inside the CD player. Should this occur, the system will not operate properly. Remove the CD and leave the system turned on for about an hour until the moisture evaporates.
- When you move the system, take out any discs.

If you have any questions or problems concerning your stereo system, please consult your nearest Sony dealer.

#### Notes on CDs

- Before playing, clean the CD with a cleaning cloth. Wipe the CD from the centre out.
- Do not use solvents such as benzene, thinner, commercially available cleaners or anti-static spray intended for vinyl LPs.
- Do not expose the CD to direct sunlight or heat sources such as hot air ducts, nor leave it in a car parked in direct sunlight.

- When using CDs that have glue or similar tacky substance on the label side of the disc or that used a special ink when the label was printed, there is a chance that the CD or label may become attached to parts inside this unit. When this occurs, it may not be possible to remove the CD, and may also cause this unit to malfunction. Be sure to check that the label side of the CD is not sticky before using.

The following types of CD should not be used:

- Rental or used CDs with attached seals where the glue extends beyond the seal. The perimeter of the seal on the CD is tacky.
- CDs that have labels printed using a special ink that feels tacky when touched.

#### Cleaning the cabinet

Use a soft cloth slightly moistened with mild detergent solution.

#### To remove the speaker grille

Use both hands and pull the grille straight forward to prevent the ribs from breaking.

#### To save a tape permanently

To prevent a tape from being accidentally recorded over, break off the cassette tab from side A or B as illustrated.

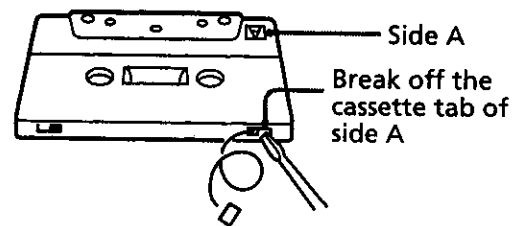
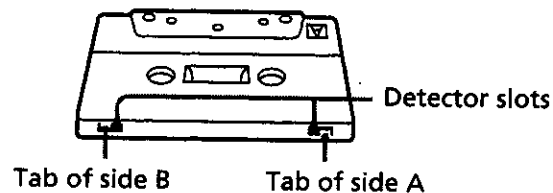

If you later want to reuse the tape for recording, cover the broken tab with adhesive tape. However, be careful not to cover the detector slots which allow the tape player to automatically detect the type of tape.

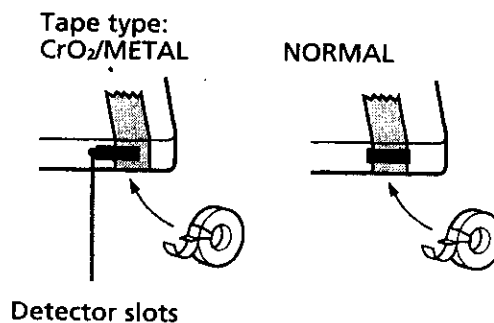

## **Before placing a cassette in the tape deck**

Take up any slack in the tape. Otherwise the tape may get entangled in the parts of the tape deck and become damaged.

## **When using a tape longer than 90 minutes**

The tape is very elastic. Do not change the tape operations such as play, stop, and fast-winding etc. frequently. The tape may get entangled in the tape deck.

## **Cleaning the tape heads**

Clean the tape heads after every 10 hours of use.

When the tape heads become dirty

- the sound is distorted
- there is a decrease in sound level
- the sound drops out
- the tape does not erase completely
- the tape does not record.

Make sure to clean the tape heads before you start an important recording or after playing an old tape. Use separately sold dry-type or wet-type cleaning cassette. For details, refer to the instructions of the cleaning cassette.

## **Demagnetizing the tape heads**

Demagnetize the tape heads and the metal parts that have contact with the tape every 20 to 30 hours of use with a separately sold demagnetizing cassette. For details, refer to the instructions of the demagnetizing cassette.

---

# **Troubleshooting**

If you run into any problem using this stereo system, use the following check list.

First, check that the power cord is connected firmly and the speakers are connected correctly and firmly.

Should any problem persist, consult your nearest Sony dealer.

---

## **General**

---

**The display starts flashing as soon as you plug in the power cord even though you haven't turned on the power (demonstration mode).**

- Press DISPLAY (U.S.A., Canadian and European models) or DEMO (STANDBY) (other models) when the power is turned off.

The demonstration disappears.

The demonstration mode appears automatically the first time you plug in the power cord or if there is a power outage lasting longer than half a day.

---

**The clock setting/radio presetting/timer is canceled.**

- The power cord is disconnected or a power failure occurs longer than half a day.

Redo the followings:

- "Step 2: Setting the time"
- "Step 3: Presetting radio stations"

If you have set the timer, also redo "Waking up to music" on page 33 and "Timer-recording radio programs" on page 34.

---

**"0:00" (or "12:00") flashes in the display.**

- A power interruption occurred. Set the clock and timer settings again.

---

**There is no sound.**

- Rotate VOLUME clockwise.
- The headphones are connected.
- Insert only the stripped portion of the speaker cord into the SPEAKER jack. Inserting the vinyl portion of the speaker cord will obstruct the speaker connections.
- There is no audio output during timer recording.

## Troubleshooting (continued)

---

### There is severe hum or noise.

- A TV or VCR is placed too close to the stereo system. Move the stereo system away from the TV or VCR.
- The A/V control amplifier is placed under the CD player/stereo cassette deck. Place the A/V control amplifier on top of the CD player/stereo cassette deck.

---

### The timer does not function.

- Set the clock correctly.

---

### "DAILY1", "DAILY 2", and "REC" do not appear when you press TIMER SELECT.

- Set the clock.
- Set the timer correctly.

---

### The remote does not function.

- There is an obstacle between the remote and the system.
- The remote is not pointing in the direction of the system's sensor.
- The batteries have run down. Replace the batteries.

---

### There is acoustic feedback.

- Decrease the volume level.
- Move the microphone away from the speakers or change the direction of the microphone.

---

### The colour irregularity on a TV screen persists.

- Turn off the TV set once, then turn it on after 15 to 30 minutes. If the colour irregularity still persists, place the speaker farther away from TV set.

---

### "PROTECT" and "PUSH POWER" appear alternately.

- A strong signal was input. Press I/⏻ to turn off the power, leave the system turned off for a while, then press I/⏻ again to turn on the power.
- 

## Speakers

---

### Sound comes from one channel or unbalanced left and right volume.

- Check the speaker connection and speaker placement.

---

### Sound lacks bass.

- Check that the speaker's + and - jacks are connected correctly.
- 

## CD Player

---

### The CD tray does not close.

- The CD is not placed properly.

---

### The CD will not play.

- The CD is not lying flat in the disc tray.
- The CD is dirty.
- The CD is inserted label side down.
- Moisture condensation has built up. Remove the CD and leave the system turned on for about an hour until the moisture evaporates.

---

### Play does not start from the first track.

- The player is in programme or shuffle mode. Press PLAY MODE repeatedly until "PROGRAM" or "SHUFFLE" disappear.

---

### "OVER" is displayed.

- You have reached the end of the CD. Press and hold ◀◀ to return.
-



## Tape Deck

---

### The tape does not record.

- No tape in the cassette holder.
- The tab has been removed from the cassette (see "To save a tape permanently" on page 38).
- The tape has reeled to the end.

### The tape does not record nor play or there is a decrease in sound level.

- The heads are dirty. Clean them (see "Cleaning the tape heads" on page 39).
- The record / playback heads are magnetized. Demagnetize them (see "Demagnetizing the tape heads" on page 39).

### The tape does not erase completely.

- The record / playback heads are magnetized. Demagnetize them (see "Demagnetizing the tape heads" on page 39).

### There is excessive wow or flutter, or the sound drops out.

- The capstans or pinch rollers are dirty. Clean them (see "Cleaning the tape heads" on page 39).

### Noise increases or the high frequencies are erased.

- The record / playback heads are magnetized. Demagnetize them (see "Demagnetizing the tape heads" on page 39).

### After pressing $\triangleright$ ( $\triangleleft$ ) or $\triangle$ , there is a mechanical noise, "EJECT" appears in the display, and the unit enters standby mode automatically.

- The cassette tape was not inserted correctly. Eject the tape and turn the power back on.
- 

## Tuner

---

### There is severe hum or noise ("TUNED" or "STEREO" flashes in the display).

- Adjust the antenna.
- The signal strength is too weak. Connect the external antenna.

### A stereo FM programme cannot be received in stereo.

- Press STEREO/MONO so that "STEREO" appears.
- 

### If other troubles not described above occur, reset the system as follows:

- 1 Unplug the power cord.
- 2 Plug the power cord back in.
- 3 Press GROOVE and I/⏻ at the same time.
- 4 Press I/⏻ to turn on the power.

The system is reset to the factory settings. All the settings you made, such as the preset stations, clock, and timer are cleared. You should set them again.

# Specifications

## Amplifier section

### For the U.S. model

#### AUDIO POWER SPECIFICATIONS:

##### POWER OUTPUT AND TOTAL HARMONIC DISTORTION:

with 6 ohm loads both channels driven, from 70-20,000 Hz; rates 100 watts per channel minimum RMS power, with no more than 0.9% total harmonic distortion from 250 milliwatts to rated output.

### North American model

#### Front Speaker:

Continuous RMS power output (reference)  
130 + 130 watts  
(6 ohms at 1 kHz,  
10% THD)

Total harmonics distortion  
Less than 0.07%  
(6 ohms at 1 kHz, 40 W)

### European model

#### Front Speaker:

DIN power output (rated) 80 + 80 watts  
(6 ohms at 1 kHz, DIN)

Continuous RMS power output (reference)  
100 + 100 watts  
(6 ohms at 1 kHz,  
10% THD)

Music power output (reference)  
160 + 160 watts  
(6 ohms at 1 kHz,  
10% THD)

### Other models

The following measured at AC 120/220/240 V,  
50/60 Hz

#### Front Speaker:

DIN power output (rated) 90 + 90 watts  
(6 ohms at 1 kHz, DIN)

Continuous RMS power output (reference)  
110 + 110 watts  
(6 ohms at 1 kHz,  
10% THD)

#### Inputs

VIDEO IN:  
(phono jacks) voltage 250 mV,  
impedance 47 kilohms

MD IN:  
(phono jacks) voltage 450 mV,  
impedance 47 kilohms

MIC:  
(mini jack) sensitivity 1 mV,  
impedance 10 kilohms

#### Outputs

MD OUT:  
(phono jacks) voltage 250 mV  
impedance 1 kilohms

PHONES:  
(stereo mini jack) accepts headphones of 8  
ohms or more

FRONT SPEAKER:  
accepts impedance of 6 to  
16 ohms

REAR SPEAKER:  
accepts impedance of 16  
ohms

SUPER WOOFER:  
Voltage 1 V, impedance 1  
kilohms

## CD player section

System Compact disc and digital  
audio system

Laser Semiconductor laser  
( $\lambda=780\text{nm}$ )

Emission duration:  
continuous

Laser output Max. 44.6  $\mu\text{W}^*$   
\*This output is the value  
measured at a distance of  
200 mm from the  
objective lens surface on  
the Optical Pick-up Block  
with 7 mm aperture.

Wavelength 780 - 790 nm

Frequency response 20 Hz - 20 kHz ( $\pm 0.5$  dB)

Signal-to-noise ratio More than 90 dB

Dynamic range More than 90 dB

CD DIGITAL OUT  
(Square optical connector jack, rear panel)

Wavelength 660 nm

Output Level -18 dBm

## Tape player section

Recording system 4-track 2-channel stereo

Frequency response 40 - 13,000 Hz ( $\pm 3$  dB),  
(DOLBY NR OFF) using Sony TYPE I  
cassette

40 - 14,000 Hz ( $\pm 3$  dB),  
using Sony TYPE II  
cassette

Wow and flutter  $\pm 0.15\%$  W.Peak (IEC)  
0.1% W.RMS (NAB)  
 $\pm 0.2\%$  W.Peak (DIN)

## Tuner section

FM stereo, FM/AM superheterodyne tuner

### FM tuner section

Tuning range  
Tourist model: 76.0 – 108.0 MHz  
Other models: 87.5 – 108.0 MHz  
Antenna FM lead antenna  
Antenna terminals 75 ohm unbalanced  
Intermediate frequency 10.7 MHz

### UKV tuner section

#### (3 band (FM-AM-UKV) models only)

Tuning range 65.0 – 74.0 MHz  
Stereo Plus

### AM tuner section

Tuning range  
2 Band type:  
North American models: 530 – 1,710 kHz  
(with the interval set at 10 kHz)  
531 – 1,710 kHz  
(with the interval set at 9 kHz)  
European models: 531 – 1,602 kHz  
(with the interval set at 9 kHz)  
Other models: 531 – 1,602 kHz  
(with the interval set at 9 kHz)  
530 – 1,710 kHz  
(with the interval set at 10 kHz)  
3 Band type:  
Middle Eastern models:  
MW: 531 – 1,602 kHz  
(with the interval set at 9 kHz)  
SW: 5.95 – 17.90 MHz  
(with the interval set at 5 kHz)  
Other models:  
MW: 531 – 1,602 kHz  
(with the interval set at 9 kHz)  
530 – 1,710 kHz  
(with the interval set at 10 kHz)  
SW: 5.95 – 17.90 MHz  
(with the interval set at 5 kHz)  
Antenna AM loop antenna  
Antenna terminals External antenna terminal  
Intermediate frequency 450 kHz

## Speaker

### Front Speaker (SS-NX1)

Speaker system 2-way, bass-reflex type, magnetically shielded type  
Speaker units  
Woofer: 17 cm (6<sup>3</sup>/<sub>4</sub> in.), cone type  
Tweeter: 2.5 cm (1 in.), dome type  
Nominal impedance 6 ohms  
Dimensions (w/h/d) Approx. 210 x 402 x 285 mm (8<sup>3</sup>/<sub>8</sub> x 15<sup>7</sup>/<sub>8</sub> x 11<sup>1</sup>/<sub>8</sub> in.)  
Mass Approx. 7.0 kg (15 lb 7 oz) net per speaker

## General

Power requirements  
North American models: 120 V AC, 60 Hz  
European models: 230 V AC, 50/60 Hz  
Australian model: 230 – 240 V AC, 50/60 Hz  
Other models: 120 V, 220 V or 230 – 240 V AC, 50/60 Hz  
Adjustable with voltage selector

Power consumption  
U.S.A model: 270 watts  
Canadian model: 270 VA  
European model: 190 watts  
Other models: 230 watts

Dimensions (w/h/d)  
STR-NX1: Approx. 225 x 202 x 356 mm (8<sup>7</sup>/<sub>8</sub> x 8 x 14<sup>1</sup>/<sub>8</sub> in.)  
HTC-NX1: Approx. 225 x 202 x 347 mm (8<sup>7</sup>/<sub>8</sub> x 8 x 13<sup>3</sup>/<sub>4</sub> in.)

Mass  
STR-NX1: Approx. 7.2 kg (15 lb 14 oz)  
HTC-NX1: Approx. 4.2 kg (9 lb 4 oz)

Supplied accessories: AM loop antenna (1)  
Remote Commander (1)  
Batteries (2)  
FM lead antenna (1)  
Speaker cords (2)  
Front speaker pads (8)

Design and specifications are subject to change without notice.

# Index

## A

- Adjusting
  - the graphic equalizer 28
  - the sound 25
  - the volume 11, 16
- Aerials 5, 37
- Automatic Source Selection 11, 13, 16

## B

- Batteries 6

## C

- CD player 18
- CD Synchro Recording 11
- Clock setting 7
- Connecting. *See* Hooking up

## D

- Daily timer 33
- DBFB 25
- Display 18

## E, F

- Edit 23

## G

- GROOVE 25

## H, I, J, K, L, M

- Hooking up
  - optional components 35
  - the aerials 5, 37
  - the main unit 4
  - the power 6

## N

- Normal Play 10

## O

- One Touch Play 11, 13, 16

## P, Q

- Personal file 29
- Playing
  - a CD 10
  - a preset radio station 12
  - a tape 15
  - tracks in random order (Shuffle Play) 19
  - tracks in the desired order (Programme Play) 20
  - tracks repeatedly (Repeat Play) 19
- Presetting radio stations 8
- Preset tuning 12
- Programme Play 20
- Protecting recordings 38
- PTY 30

## R

- Radio Data System (RDS) 30
- Radio stations
  - presetting 8
  - tuning in 12
- Recording
  - a CD 11
  - a radio programme 14
  - timer recording 34
- Repeat Play 19
- Resetting the system 41

## S

- Saving recordings 38
- Selecting the audio emphasis 26
- Setting the time 7
- Shuffle Play 19
- Sleep Timer 32
- Sound adjustment 25
- Speakers 36
- Station name 30

## T, U, V, W, X, Y, Z

- Timer
  - falling asleep to music 32
  - timer recording 34
  - waking up to music 33
- Troubleshooting 39
- Tuner 12, 30
- Tuning interval 8