

Stereo Turntable System

Operating Instructions _____

GB**OWNER'S RECORD**

The model and serial numbers are located at the rear. Record the serial number in the space provided below. Refer to them whenever you call upon your Sony dealer regarding this product.

Model No. PS-LX250H Serial No. _____

PS-LX250H

WARNING

To prevent fire or shock hazard, do not expose the unit to rain or moisture.

Do not install the appliance in a confined space, such as a bookcase or built-in cabinet.

For the customers in the U.S.A.

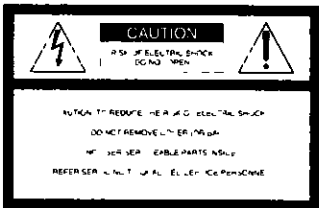

This symbol is intended to alert the user to the presence of uninsulated "dangerous voltage" within the product's enclosure that may be of sufficient magnitude to constitute a risk of electric shock to persons



This symbol is intended to alert the user to the presence of important operating and maintenance (servicing) instructions in the literature accompanying the appliance

CAUTION

You are cautioned that any changes or modification not expressly approved in this manual could void your authority to operate this equipment

For the customers in Canada

CAUTION

TO PREVENT ELECTRIC SHOCK, DO NOT USE THIS POLARIZED AC PLUG WITH AN EXTENSION CORD, RECEPTACLE OR OTHER OUTLET UNLESS THE BLADES CAN BE FULLY INSERTED TO PREVENT BLADE EXPOSURE

Precautions

On safety

- Before operating the unit, check that the operating voltage of your unit is identical with that of your local power supply
- Should any solid object or liquid fall into the cabinet, unplug the unit and have it checked by qualified personnel before operating it any further
- Unplug the unit from the wall outlet if it is not to be used for an extended period of time. To disconnect the cord, pull it out by the plug. Never pull the cord itself
- The unit is not disconnected from the AC power source (mains) as long as it is connected to the wall outlet, even if the unit itself has been turned off
- The nameplate indicating operating voltage, power consumption, etc. is located on the rear exterior

On placement

- Place the unit on a level surface
- Avoid placing the unit near electrical appliances (such as a television, hair dryer, or fluorescent lamp) which may cause hum or noise
- Place the unit where it will not be subject to any vibration, such as from speakers, slamming of doors, etc
- Keep the unit away from direct sunlight, extremes of temperature, and excessive dust and moisture

On repacking

Keep the carton and packing materials. They provide an ideal container to transport the unit

Welcome!

Thank you for purchasing the Sony Stereo Turntable System. Before operating the unit, please read this manual thoroughly and retain it for future reference.

Convention

The following icon is used in this manual:



Indicates hints and tips for making the task easier.

TABLE OF CONTENTS

Getting Started

- Unpacking 3
 - Assembling the Turntable 4
 - Hooking up the Turntable 4
-

Operations

- Playing a Record 5
-

Additional Information

- Maintenance 6
- Troubleshooting 7
- Specifications 7
- Parts and Controls 8

GB

Unpacking

Check that you received the following items with your turntable:

- Platter (with drive belt) (1)
- Rubber mat (1)
- Dust cover (with hinges) (1)
- 45 r/min adaptor (1)

Assembling the Turntable

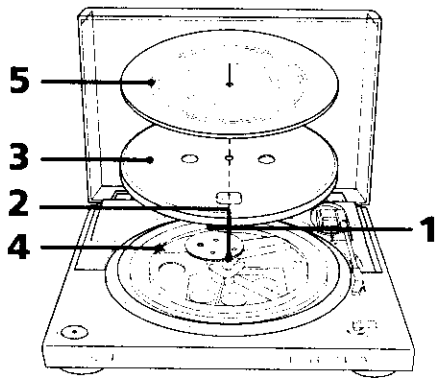

- 1 Set the EQ switch according to the jacks of your stereo system (amplifier).
 - When your stereo system (amplifier) has PHONO input jacks (connect to PHONO input jacks) → set to OFF.
 - When your stereo system (amplifier) does not have PHONO input jacks (connect to AUX, VIDEO input jacks, etc.) → set to ON.

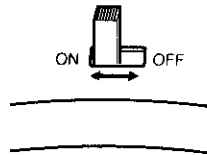

- 2 Move the metallic parts inside the larger gear in the direction of arrows.

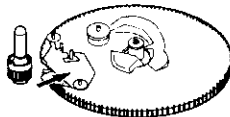

When the power is supplied after assembling or moving the turntable

The turntable sometimes rotates and the tone arm descends to the platter even if START is not pressed. If this occurs, press STOP to return the tone arm to the arm stand.

- 3 Carefully, place the platter on the spindle.
- 4 Using the ribbon, loop the drive belt around the motor pulley. After looping the belt, do not forget to remove the ribbon.

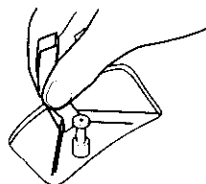

- 5 Place the rubber mat on the platter.

Installing the dust cover

Insert the hinges on the dust cover into the hinge pockets on the rear of the cabinet.

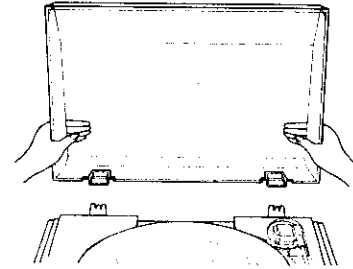

Hooking up the Turntable

The phono cables come attached to the rear of the cabinet.

- 1 Connect the cable with the white plug to the white (L) jack and connect the cable with the red plug to the red (R) jack. Make sure to insert the plugs firmly into the jacks. If the plugs are not inserted firmly, noise may be occurred.

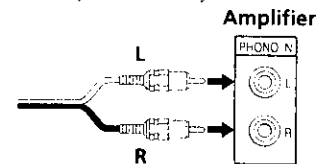

It is necessary to set the EQ switch according to the connected jacks. For details, refer to step 1 in "Assembling the Turntable".

Mains lead hookups

Connect the mains lead to an AC wall outlet after completing all of the previous connections.

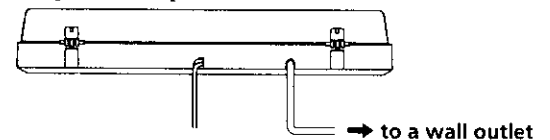

Playing a Record

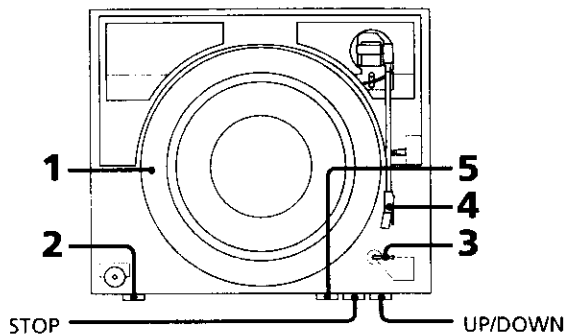

- 1 Place a record on the platter.

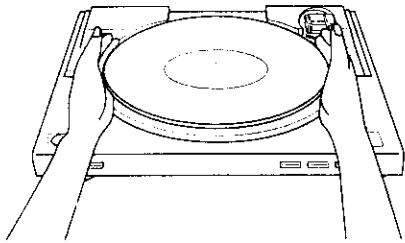

Note

Place only one record on the platter at a time. If two or more records are stacked on the platter, the stylus will not make proper contact with the grooves and the quality of reproduction will be impaired.

- 2 Press the Speed select button to select the speed.
- 3 Set the SIZE SELECTOR to 17 or 30.
- 4 Remove the protective cover from the cartridge, and close the dust cover.
- 5 Press START.
The platter starts rotating.
- 6 Adjust the volume on your amplifier.

To stop playing

Press STOP.

To pause playback

Press the UP/DOWN button to raise the stylus off the record.

To listen to a different part of the record

- 1 Press UP/DOWN button.
- 2 Move the tone arm to the position you desire.
- 3 Press UP/DOWN button.
The tone arm descends to the record.

To play a 17-cm record

Place the supplied 45 r/min adaptor on the spindle. When you have finished using the adaptor, put it back in the adaptor tray.

Maintenance

Stylus and Record Care

In order to prevent premature stylus and record wear, the stylus and record should be cleaned before playback.

To clean the stylus, brush it from back to front using a good quality stylus cleaning brush. Do not clean the stylus with your finger tip. When using a fluid stylus cleaner, make sure not to moisten the stylus too much.

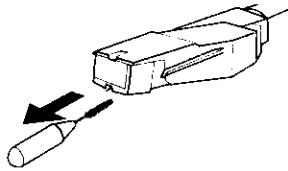

To clean your records, wipe thoroughly using a good quality record cleaner.

Cleaning the Cabinet and Dust Cover

Clean the cabinet and dust cover periodically using a soft dry cloth. If stains are difficult to remove, use a cloth moistened with a mild detergent solution. Do not use solvents such as alcohol, benzine or thinner, since they will damage the finish.

Replacing the Stylus

The life expectancy of the stylus tip is about 500 hours. To preserve maximum sound quality and avoid damage to your records, we recommend replacing the stylus within this time limit.

Additional replacement styli (ATN3600LX) are available from your Sony dealer.

To replace the stylus

- 1 Turn off the amplifier.
- 2 Grasp the stylus holder and pull it away from the body of the cartridge.
- 3 Insert the new stylus by pushing it into the cartridge receptacle.

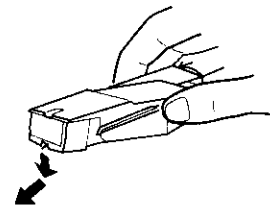

Troubleshooting

Before going through the check list below, first make sure that:

- The power cord is securely connected.
- The speaker cords are securely connected.

Should any problem persist after you have made these checks, consult your nearest Sony dealer.

The tone arm skips, skates or does not advance.

- ◆ The turntable is not level. Place the turntable on a level surface.
- ◆ The record is dirty or scratched.
Clean the record with a commercially available record cleaning kit, or replace the record.

Poor sound quality, excessive noise, intermittent sound, etc...

- ◆ The stylus is dirty or worn. Remove dust on the stylus using a stylus cleaning brush, or replace the worn stylus (see page 6).
- ◆ Dust or dirt has collected on the record. Clean the record using a good quality record cleaner.

Rumble or low-frequency howl*.

- ◆ The turntable is placed too close to speakers. Move speakers away from the turntable.

Tempo is incorrect.

- ◆ Incorrect r/min. Set the r/min setting to match the one indicated on the record. (Select "33" for 33 1/3 r/min records or "45" for 45 r/min records.)

The drive belt is deteriorated.

- ◆ Replace the drive belt. For details, please make a contact with Sony dealer.

Platter does not rotate.

- ◆ Make sure the power cord is inserted all the way into an AC wall outlet.

The drive belt is broken.

- ◆ Replace the drive belt. For details, please make a contact with Sony dealer.

Sound is too low or distorted.

- ◆ The turntable is not connected to the PHONO IN inputs on the amplifier (see page 4).

* This phenomenon, called "acoustic feedback", occurs when vibrations from the speakers are transmitted through the air or via solid objects (such as shelves, a cabinet, or the floor) to the turntable where they are picked up by the stylus, amplified and reproduced through the speakers.

Specifications

Motor and Platter

Drive system	Belt-drive
Motor	DC motor
Platter	295 mm dia. (aluminum, die-cast)
Speeds	33 1/3 and 45 r/min, 2 speed
Wow and flutter	Less than 0.25% (WRMS)
Signal to noise ratio	More than 50 dB (DIN-B)

Tone Arm

Type	Dynamic balanced straight shaped with soft damping control
Effective arm length	195 mm

General

Power requirements	U.S.A. and Canada: 120 V AC, 60 Hz European countries: 230 V, 50/60 Hz
Power consumption	2 W
Dimensions	Approx. 420 x 100 x 342 mm (w/h/d)
Mass	2.7 kg

Supplied Accessories

45 r/min adaptor (1)
Platter (with drive belt) (1)
Rubber mat (1)
Dust cover (1)

Design and specifications are subject to change without notice.

Parts and Controls

- | | |
|----------------------------------|--------------------------|
| 1 EQ switch | 10 Dust cover |
| 2 Spindle | 11 Hinge |
| 3 45 r/min adaptor | 12 Tone arm |
| 4 Speed select button | 13 Arm stand |
| 5 Rubber mat | 14 Finger lift |
| 6 Platter | 15 SIZE SELECTOR |
| 7 Cartridge and headshell | 16 STOP button |
| 8 START button | 17 UP/DOWN button |
| 9 Insulator | |

