

Digital Palmcorder®
PalmSight™

Panasonic®

Digital Video Camcorder
Operating Instructions
Model No. **PV-DV100**

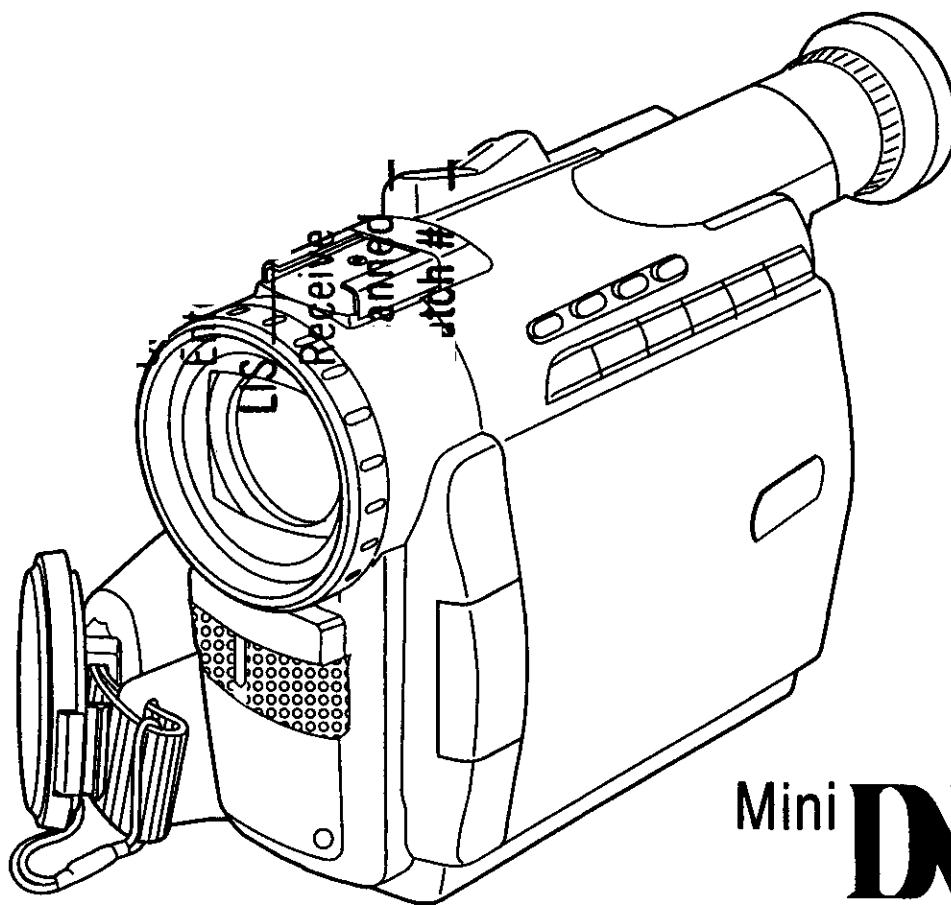

Mini **DV**



Before attempting to connect, operate or adjust this product, please read these instructions thoroughly.

Spanish Quick Use Guide is included.

Guía para rápida consulta en español está incluida.

For assistance, call 1-800-211-PANA(7262)

LSQT0211A

Things You Should Know

Thank you for choosing Panasonic!

You have purchased one of the most sophisticated and reliable products on the market today. Used properly, we're sure it will bring you and your family years of enjoyment. Please take time to fill in the information below. The serial number is on the tag located on the underside of your Palmcorder. Be sure to **retain this manual** as your convenient Palmcorder information source.

Date of Purchase
Dealer Purchased From
Dealer Address
Dealer Phone No.
Model No.
Serial No.

Unpack your Camcorder

1 pc. AC Adaptor
(PV-DAC10)
with AC Cable and DC
Cable

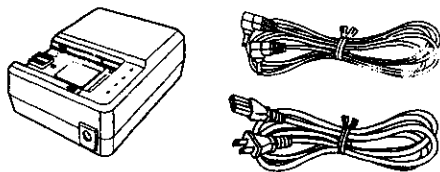

1 pc. Battery Pack
(PV-DBP8 or PV-
DBP8A)

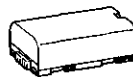

1 pc. AV Cable
(LSJA0280)

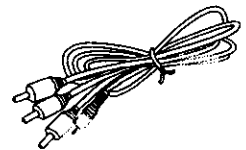

1 pc. Lens Cap
(LSYF0395)



1 pc. PC Connection
Cable for Windows
(LSJA0276)

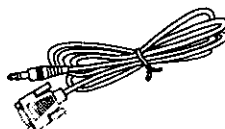

1 pc. PHOTOVU LINK
DRIVER (LSFT0195)

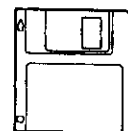

1 pc. Shoulder
Strap (LSFC0013)



Microsoft and Windows are registered trademarks of Microsoft in the United States and other countries.

Things You Should Know

Safety Precautions

**WARNING: TO PREVENT FIRE OR SHOCK HAZARD,
DO NOT EXPOSE THIS EQUIPMENT TO RAIN OR MOISTURE.**

Your MiniDV Palmcorder is designed to record and play back in Standard Play (SP) mode and Long (LP) mode.

It is recommended that only cassette tapes that have been tested and inspected for use in VCR machines with the MiniDV mark be used.

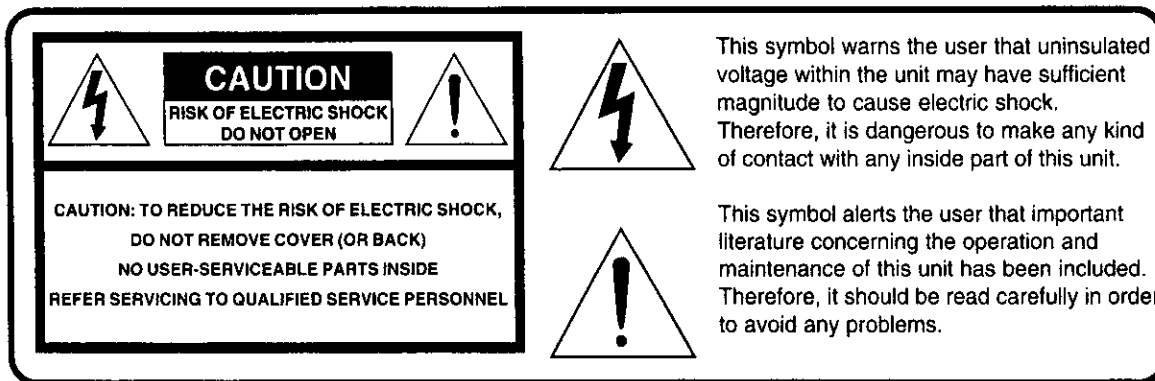

The above markings are located on the appliance bottom cover.

This device complies with Part 15 of the FCC Rules. Operation is subject to the following two conditions: (1) This device may not cause harmful interference, and (2) this device must accept any interference received, including interference that may cause undesired operation.

Note: This equipment has been tested and found to comply with Part 15 of the FCC Rules. These limits are designed to provide reasonable protection against harmful interference when operated in a residential environment.

If this equipment does cause interference to radio or television reception, which can be determined by turning the equipment off and on, use the equipment in another location and/or utilize an electrical outlet different from that used by the receiver.

If necessary, consult the dealer or an experienced radio/TV technician for help. You may find the booklet, 'Something About Interference' available from FCC local regional offices helpful.

FCC Warning: To assure continued FCC compliance, use only the provided shielded interface cable when connecting digital video camera to computer in accordance with instruction herein. Also, any unauthorized changes or modifications to this equipment could void the user's authority to operate.

Important Safeguards

1. **Read Instructions** — All the safety and operating instructions should be read before the unit is operated.
2. **Retain Instructions** — The safety and operating instructions should be retained for future reference.
3. **Heed Warnings** — All warnings on the unit and in the operating instructions should be adhered to.
4. **Follow Instructions** — All operating and maintenance instructions should be followed.
5. **Cleaning** — Unplug this video unit from the wall outlet before cleaning. Do not use liquid or aerosol cleaners. Use a dry cloth for cleaning.
6. **Attachments** — Do not use attachments not recommended by the video product manufacturer as they may be hazardous.
7. **Water and Moisture** — Do not use this video unit near water — for example near a bath tub, wash bowl, kitchen sink, or laundry tub, in a wet basement, or near a swimming pool, and the like.
8. **Accessories** — Do not place this video unit on an unstable cart, stand, tripod, bracket, or table. The video unit may fall, causing serious injury to a child or adult, and serious damage to the unit. Use only with a cart, stand, tripod, bracket, or table recommended by the manufacturer, or sold with the video unit. Any mounting of the unit should follow the manufacturer's instructions and should use a mounting accessory recommended by the manufacturer. An appliance and cart combination should be moved with care. Quick stops, excessive force, and uneven surfaces may cause the appliance and cart combination to overturn.
9. **Ventilation** — Slots and openings in the cabinet are provided for ventilation and to ensure reliable operation of the video unit and to protect it from overheating. These openings must not be blocked or covered. Never place the video unit on a bed, sofa, rug, or other similar surface, or near or over a radiator or heat register. This video unit should not be placed in a built-in installation such as a bookcase or rack unless proper ventilation is provided or the manufacturer's instructions have been adhered to.
10. **Power Sources** — This video unit should be operated only from the type of power source indicated on the marking label. If you are not sure of the type of power supply to your home, consult your appliance dealer or local power company. For video units intended to be operated from battery power, or other sources, refer to the operating instructions.



11. **Grounding or Polarization** — This video unit may be equipped with either a polarized 2-wire AC (Alternating Current) line plug (a plug having one blade wider than the other) or 3-wire grounding type plug, a plug having a third (grounding) pin. The 2-wire polarized plug will fit into the power outlet only one way. This is a safety feature. If you are unable to insert the plug fully into the outlet, try reversing the plug. If the plug still fails to fit, contact your electrician to replace your obsolete outlet. Do not defeat the safety purpose of the polarized plug. The 3-wire grounding type plug will fit into a grounding type power outlet. This is a safety feature. If you are unable to insert the plug into the outlet, contact your electrician to replace your obsolete outlet. Do not defeat the safety purpose of the grounding type plug.
12. **Power-Cord Protection** — Power-supply cords should be routed so that they are not likely to be walked on or pinched by items placed upon or against them, paying particular attention to cords of plugs, convenience receptacles, and the point where they exit from the unit.
13. **Outdoor Antenna Grounding** — If an outside antenna or cable system is connected to the video unit, be sure the antenna or cable system is grounded so as to provide some protection against voltage surges and built-up static charges. Part 1 of the Canadian Electrical Code, in USA Section 810 of the National Electrical Code, provides information with respect to proper grounding of the mast and supporting structure, grounding of the lead-in wire to an antenna discharge unit, size of grounding conductors, location of antenna discharge unit, connection to grounding electrodes, and requirements for the grounding electrode.

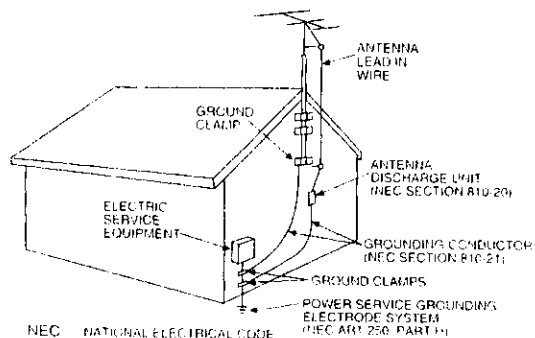

14. **Lightning** — For added protection of this video unit receiver during a lightning storm, or when it is left unattended and unused for long periods of time, unplug it from the wall outlet and disconnect the antenna or cable system. This will prevent damage to the video unit due to lightning and power-line surges.

Important Safeguards

15. **Power Lines** — An outside antenna system should not be located in the vicinity of overhead power lines or other electric light or power circuits, or where it can fall into such power lines or circuits. When installing an outside antenna system, extreme care should be taken to keep from touching such power lines or circuits as contact with them might be fatal.
16. **Overloading** — Do not overload wall outlets and extension cords as this can result in a risk of fire or electric shock.
17. **Objects and Liquids** — Never push objects of any kind into this video unit through openings as they may touch dangerous voltage points or short out parts that could result in a fire or electric shock. Never spill liquid of any kind onto the video unit.
18. **Servicing** — Do not attempt to service this video unit yourself as opening or removing covers may expose you to dangerous voltage or other hazards. Refer all servicing to qualified service personnel.
19. **Damage Requiring Service** — Unplug this video unit from the wall outlet and refer servicing to qualified service personnel under the following conditions:
 - a. When the power-supply cord or plug is damaged.
 - b. If any liquid has been spilled onto, or objects have fallen into the video unit.
 - c. If the video unit has been exposed to rain or water.
 - d. If the video unit does not operate normally by following the operating instructions. Adjust only those controls that are covered by the operating instructions, as an improper adjustment of other controls may result in damage and will often require extensive work by a qualified technician to restore the video unit to its normal operation.
 - e. If the video unit has been dropped or the cabinet has been damaged.
 - f. When the video unit exhibits a distinct change in performance — this indicates a need for service.
20. **Replacement Parts** — When replacement parts are required, be sure the service technician has used replacement parts specified by the manufacturer or have the same characteristics as the original part. Unauthorized substitutions may result in fire, electric shock or other hazards.
21. **Safety Check**— Upon completion of any service or repairs to this video unit, ask the service technician to perform safety checks to determine that the video unit is in safe operating order.

Precautions

USE & LOCATION

- **TO AVOID SHOCK HAZARD** ... Your Camcorder and power supply should not be exposed to rain or moisture. Do not connect the power supply or operate your Camcorder if it gets wet. Your Camcorder has been designed for outdoor use, however it is not designed to sustain direct exposure to water, rain, sleet, snow, sand, dust, or a direct splashing from a pool or even a cup of coffee. This action could permanently damage the internal parts of your Camcorder. Do not attempt to disassemble this unit. There are no user serviceable parts inside. Unplug your Camcorder from the power supply before cleaning.
- **DO NOT AIM YOUR CAMCORDER AT THE SUN OR OTHER BRIGHT OBJECTS**
- **DO NOT LEAVE THE PALMCORDER WITH THE EVF AIMED DIRECTLY AT THE SUN AS THIS MAY CAUSE DAMAGE TO THE INTERNAL PARTS OF THE EVF**
- **DO NOT EXPOSE YOUR CAMCORDER TO EXTENDED HIGH TEMPERATURE** ... Such as, in direct sunlight, inside a closed car, next to a heater, etc... This action could permanently damage the internal parts of your Camcorder.
- **AVOID SUDDEN CHANGES IN TEMPERATURE** ... If the unit is suddenly moved from a cold place to a warm place, moisture may form on the tape and inside the unit.
- **DO NOT LEAVE YOUR CAMCORDER OR THE POWER SUPPLY TURNED ON WHEN NOT IN USE.**
- **STORAGE OF YOUR CAMCORDER** ... Store and handle your Camcorder in a manner that will not subject it to unnecessary movement (avoid shaking and striking). Your Camcorder contains a sensitive pick-up device which could be damaged by improper handling or storage.

CARE

- **TO CLEAN YOUR CAMCORDER** ... Do not use strong or abrasive detergents when cleaning your Camcorder body.
- **TO PROTECT THE LENS** ... Do not touch the surface of the lens with your hand. Use a commercial camcorder lens solution and lens paper when cleaning the lens. Improper cleaning can scratch the lens coating.
- **TO PROTECT THE FINISH OF YOUR CAMCORDER** ... Before handling your Camcorder, make sure your hands and face are free from any chemical products, such as suntan lotion, as it may damage the finish.

Table of Contents

Getting Started

Things You Should Know	2
Important Safeguards	4
Precautions	5
Quick Guide	7
Supplying Power	9
Cassette Information	12
Color Enhancement Light (Optional)	14
Attaching the Shoulder Strap	15
Setting the Clock	17
Using the Palmcorder Menu	18
MENU OSD	19
Electronic Viewfinder/LCD Monitor Indications	24

Basic Operation

Camera Recording	28
Remote Control (Optional)	32
Playback Your Recordings	33

Special Features

Dual Digital Electronic Image Stabilization System (D.E.I.S.)	39
Zoom	40
Digital PhotoShot	41
Index Search	41
White Balance	42
Recording Still Pictures	42
Program AE	43
Digital Functions	44
Focus	45
Audio/Video Fade In/Out	46
Backlight	46
High Speed Shutter	47
Audio Dubbing using the External or Built-in Microphone	48
Memory-Stop Editing	49
Copying your Tapes to S-VHS or VHS Cassette	50
Copying from Digital Equipment (dubbing)	51
PC Connection with DV Interface Cable (IEEE 1394)	52
PC Connection	53
Software Installation (Windows 95/98)	54
PHOTOVU LINK	55
Printer Connection	57

For Your Information

Palmcorder Accessory System	58
Palmcorder Accessory Order Form	59
Notes On Operations	60
Specifications	62
Before Requesting Service	63
Request for Service Notice	65
Index of Controls	66
Warranty	70
Spanish Quick Use Guide/Guía Para Uso Rápido	72
Index	74

Quick Guide

Insert the Battery

Before you begin...

- Charge the Battery (page 9).

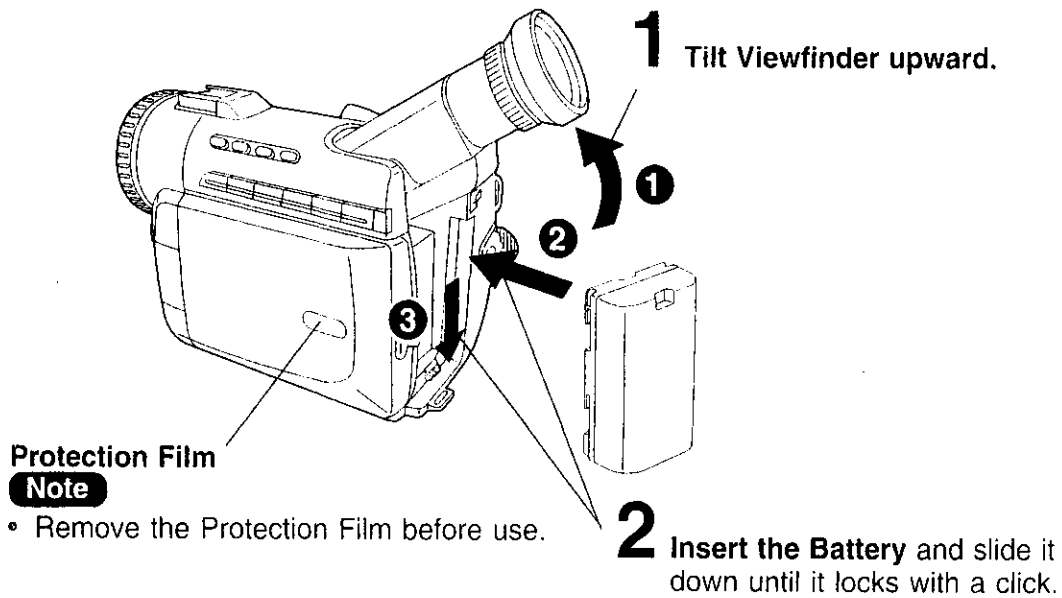

Insert Cassette

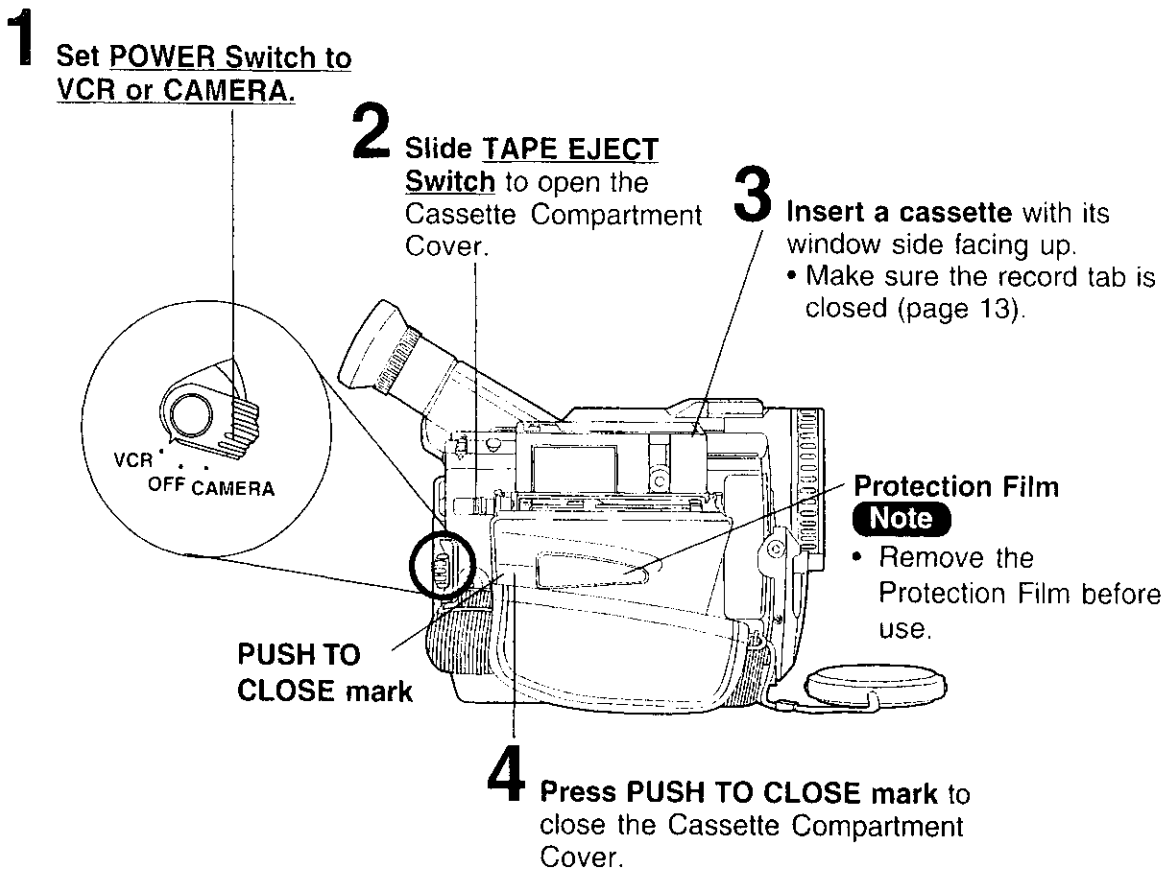

Quick Guide

Camera Recording

When the LCD monitor is fully open, the Viewfinder automatically turns OFF.

2 Adjust the Vision Adjustment Control to your eyesight.

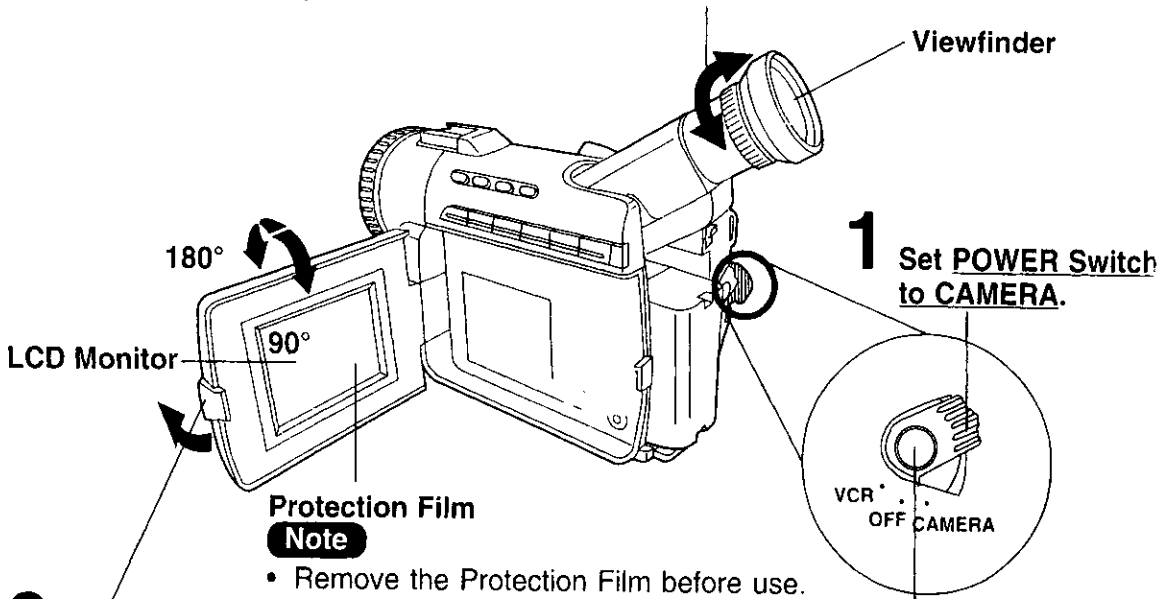

3 Press **LCD-OPEN Button** to unlock the LCD monitor. Swing it fully open and adjust the angle.

4 Press **RECORD/PAUSE Button** to start recording. Press **RECORD/PAUSE Button** again to pause recording.

To Watch Playback in the LCD (Liquid Crystal Display)

When the LCD monitor is fully open, the Viewfinder automatically turns OFF.

Before you begin...

- Charge the Battery (page 9).

2 Press **LCD-OPEN Button** to unlock the LCD monitor. Swing it fully open and adjust the angle.

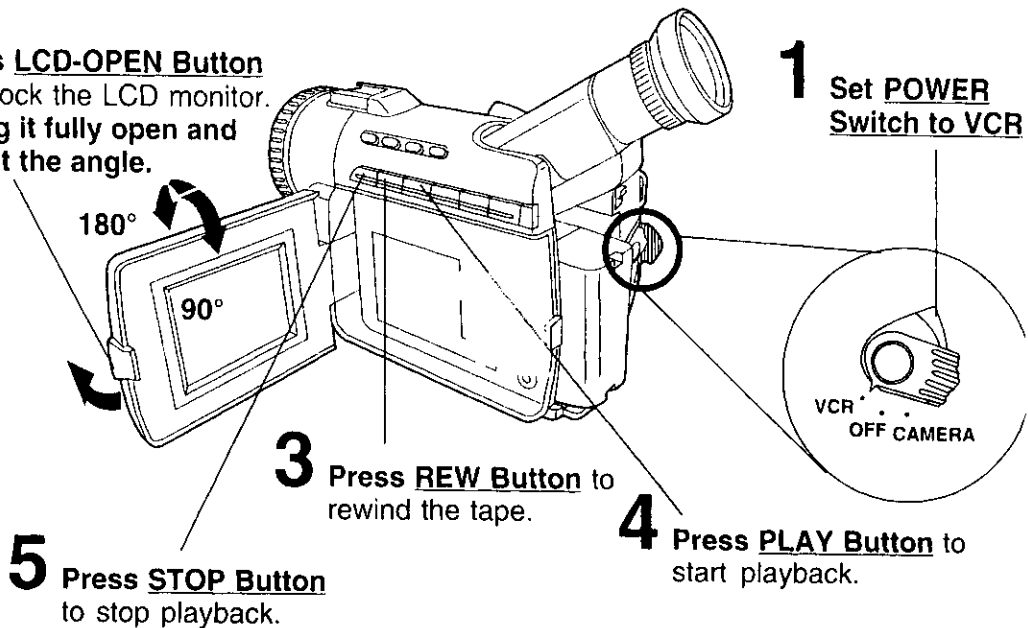

Supplying Power

Charge the Battery Pack on the AC Adaptor

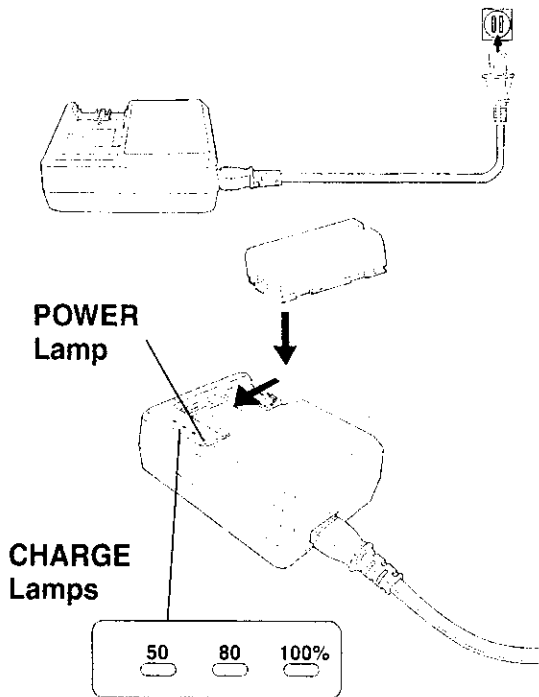

1 Connect and plug in the Cable as shown.
• POWER Lamp will light.

2 Attach the battery as shown to charge.
• Charge lamps on the AC Adaptor will flash and then turn solid red to indicate current charge level. When all 3 lamps are constantly on, the battery is fully charged. (approx. 1 hour) Expect approx. 1 hour 15 minutes of operation when fully charged (EVF usage).

3 Remove the Battery.
Slide the Battery out and then lift up.

Charge Lamps

- The three Charge Lamps "50%", "80%" and "100%" flash and then remain lit one after another to indicate how much the Battery has been charged. When all three lamps are lit, charging is finished.
- The Charge Lamps give a good approximate indication of the charging condition under normal ambient temperature. However, when charging at high or low temperature, the charge lamps may differ considerably from the actual charging condition.

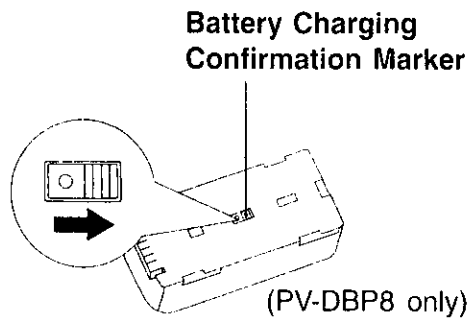

Battery Charging Confirmation Marker

Use this marker as a reminder to yourself when the battery is fully charged or in need of a charge. This marker performs no function and is for your reference only.

- The Battery is no longer serviceable if the operation time is very short, even after a sufficient charge.

Note

- PV-DBP8A has no marker.

Supplying Power

Insert/Remove the Battery Pack

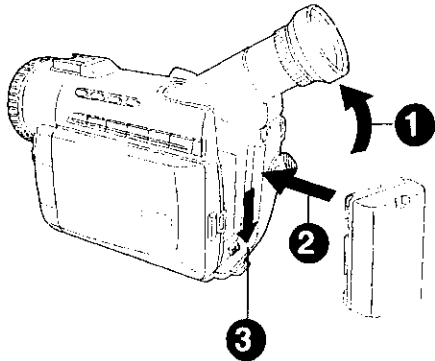

- 1 Tilt Viewfinder upward.
- 2 Insert the Battery and slide it down until it locks with a click.

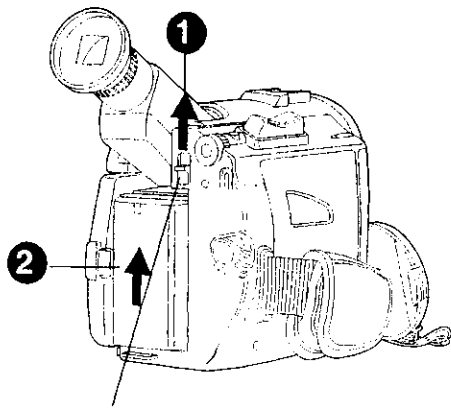

- To remove the Battery:**
Slide the Battery upward while sliding the BATTERY RELEASE.

BATTERY RELEASE Switch

Battery Care

Caution:

- Charge only with specified charger.
- The Battery can be charged within a temperature range of 32° F (0° C) and 104° F (40° C).
- The Battery may be warm after charging or just after use. This is normal.
- Do not use an insufficiently charged or worn out Battery.
- In extreme cold surroundings, Battery charging time will increase.

Safety precautions:

- Do not get the Battery near, or dispose of in fire.
- Do not directly connect (short circuit) the positive (+) and negative (-) terminals.
- Never attempt to disassemble or reassemble the Battery.

To avoid damage to the Battery:

- Do not drop or jar the Battery.
- Use the Battery with specified models only.
- If the Battery is used in extremely high temperatures, a safety device will automatically prevent operation.

To insure longer battery life:

- While not in use, remove Battery from the Palmcorder and AC Adaptor and store in a cool, dark, dry place. If you leave the Battery in the Palmcorder or on AC Adaptor, the Battery will no longer be rechargeable.
- Keep the Battery terminals clean.

Supplying Power

AC Adaptor

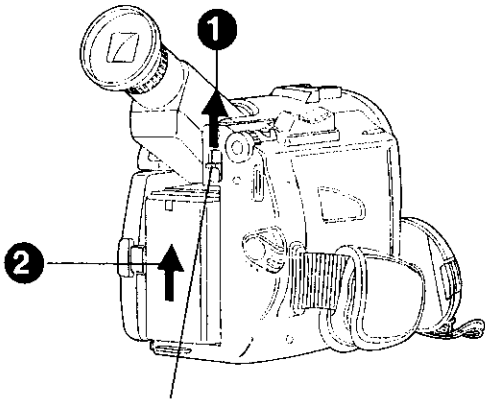

BATTERY RELEASE Switch

- 1 Slide the Battery upward while sliding the **BATTERY RELEASE** to **remove the Battery** (page 10).

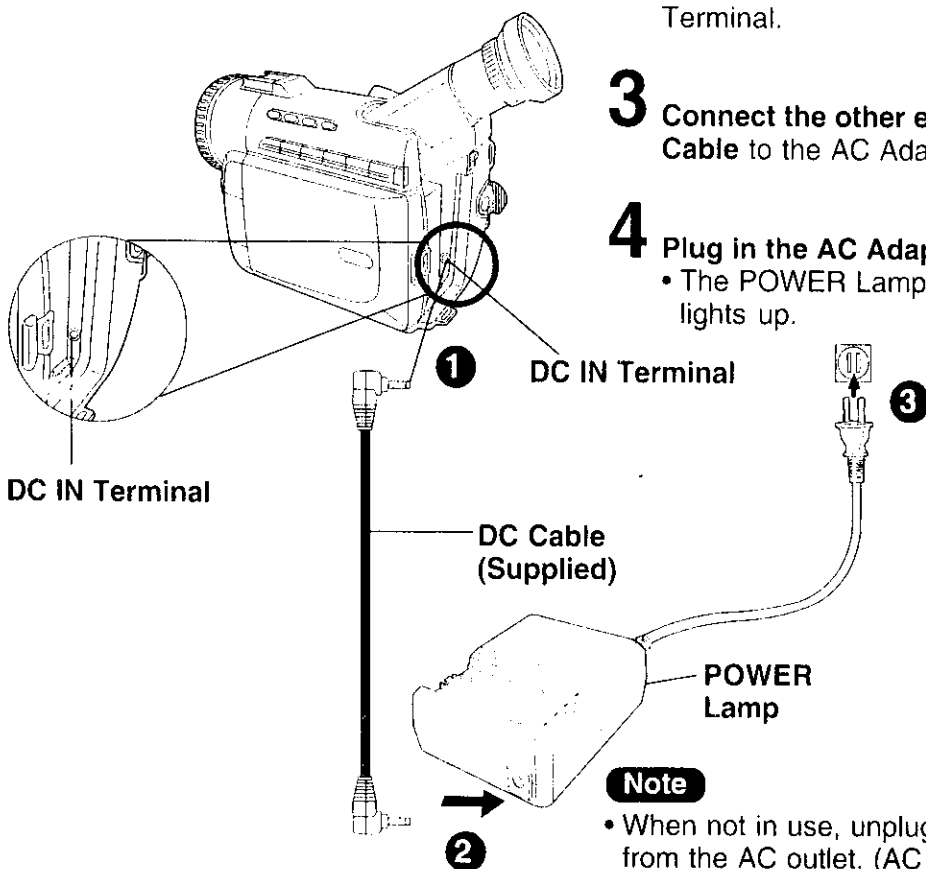

- 2 Insert the DC Cable into the DC IN Terminal.
- 3 Connect the other end of the DC Cable to the AC Adaptor as shown.
- 4 Plug in the AC Adaptor.
 - The POWER Lamp of the AC Adaptor lights up.

Note

- When not in use, unplug the AC Adaptor from the AC outlet. (AC Adaptor consumes 1W of electric power when plugged into an AC outlet even when not in use.)

Cassette Information

Cassette Insertion

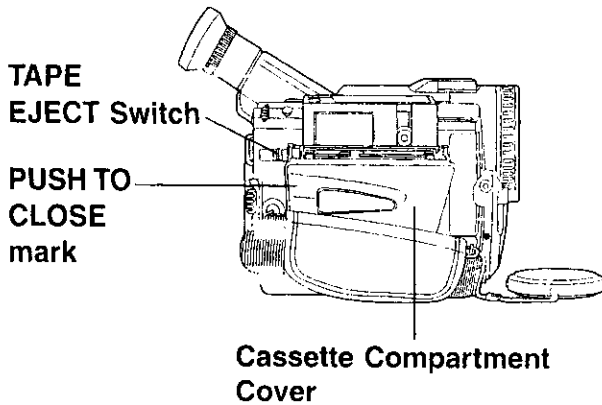

Before you begin...

- Connect the Palmcorder to a power source (pages 10, 11).

- 1** Slide **TAPE EJECT** to open the Cassette Compartment Cover.
- 2** Insert a cassette with its window side facing up.
- 3** Press **PUSH TO CLOSE** mark to close the Cassette Compartment Cover.

Cassette Ejection

- If the Palmcorder is connected to a power source, the cassette can be inserted and ejected without turning the Palmcorder on.

- 1** Slide **TAPE EJECT** to open the Cassette Compartment Cover.
- 2** Pull the cassette tape straight out.

Hint for recording position when inserting Cassette

- When you insert a cassette that is partially recorded, use the Edit Search Function to search for the position from which you want to record again. Especially when you want to record again on a cassette that is already fully recorded, be sure to first locate the position where you want to add the new recording, before starting to record.

Note:

- If hand strap is tight it may prevent Cassette Compartment Cover from fully opening for tape insert or eject. Loosen hand strap if necessary.
- When inserting the cassette, make sure it faces in the right direction and then push in completely.

Cassette Information

Record Speed/Playback Time

Use only those tapes having the **Mini DV** logo indicating the 6.35mm digital standard.

Cassette type	Record Speed/Playback time	
	SP	LP
AY-DVM30EA	30 minutes	45 minutes
AY-DVM60EA	60 minutes	90 minutes
AY-DVM80EA	80 minutes	120 minutes

Erase Protection

Cassettes have a sliding record tab to ensure recordings are not accidentally erased.

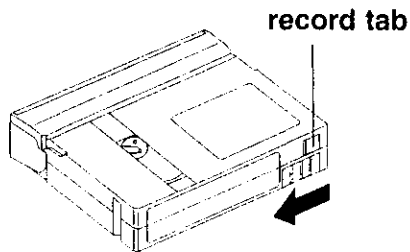

- 1 To prevent accidental erasure**
Slide the tab to the left (open).

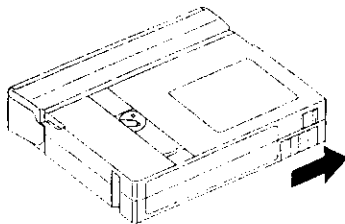

- 2 To record again**
Slide the tab to the right (close).

Color Enhancement Light (Optional) ³

Using the Light

To brighten the natural colors in a scene.

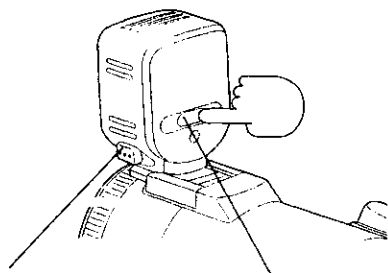
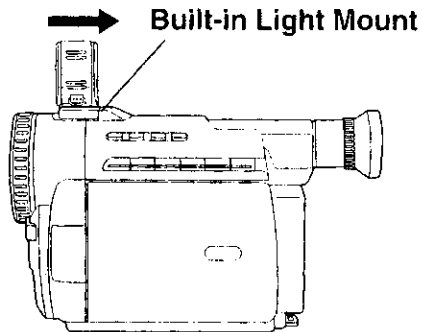

LIGHT RELEASE Button LIGHT Button

Before you begin...

- Connect the Palmcorder to a power source (pages 10, 11).
- Set POWER to CAMERA.

1 Slide Light into the Built-in Light Mount.

Be sure it locks into place.

2 Press LIGHT ON.

3 Press LIGHT again to OFF.

To remove the Light:

Press LIGHT RELEASE and slide the Light out of the mount.

Caution:

This light becomes hot during operation. Make sure nothing covers the Light during operation.

Note

- Using the light will reduce battery operating time.
- If using the enhancement Light for an extended period of time, be sure to provide ventilation when using it in a hot environment.
- Be sure LIGHT is set to OFF when not in use.
- Do not attempt to lift or carry the Palmcorder by holding the Enhancement Light.
- If light bulb needs to be replaced, take Light to your nearest authorized service center.

Attaching the Shoulder Strap

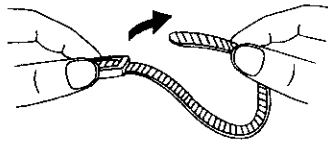

1 Undo the two strap ends from their buckles.

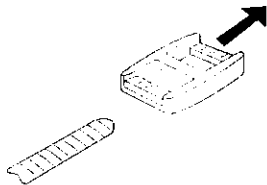

2 Remove the buckles from one end of the strap.

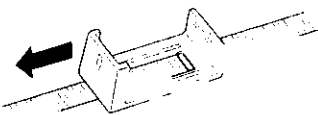

3 Thread the strap (with no buckle) through the Light Holder so that it faces outward. Then reinsert the buckle.

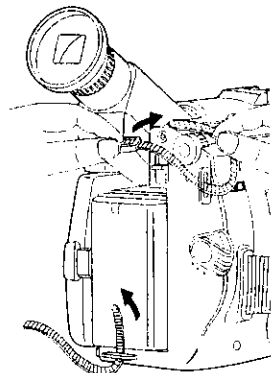

4 Thread the strap ends through the Strap Attachment Rings.

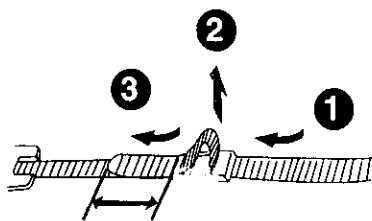

5 Reinsert the strap ends through their buckles.
• Make sure the straps are not twisted.

Adjust the Length

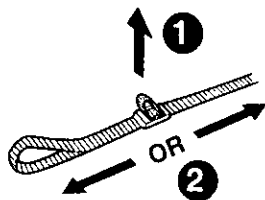

1 Loosen the strap from the Buckle and create a loop.

2 Pull the strap firmly through the Buckle to shorten or lengthen the strap.

Attaching the Shoulder Strap

Attach the Light (Optional)

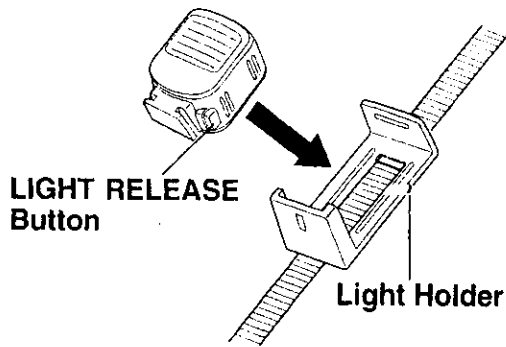

- 1 Insert the Light into the Light Holder for Storage.
- 2 To remove the Light, press **LIGHT RELEASE** and slide Light out from the holder.

Hand Strap

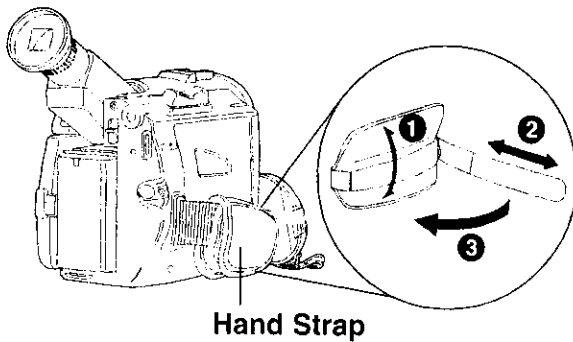

Adjust the length of the Hand Strap to the size of your hand as illustrated.

Lens Cap

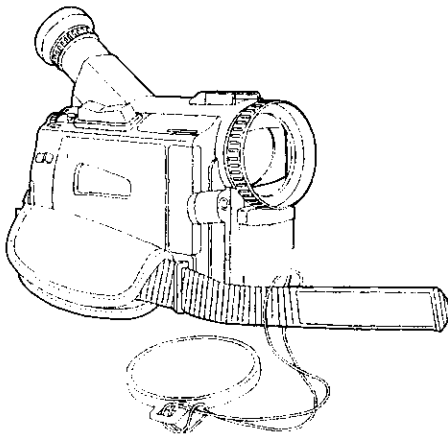

Attaching the Lens Cap Cord to the Hand Strap

Remove the Hand Strap from the front clasp and run the Strap through the Lens Cap Loop.
Reattach the Hand Strap.

Setting the Clock

Set the Date and Time

The date and time is calculated, including leap year, up to DEC 31 2089.

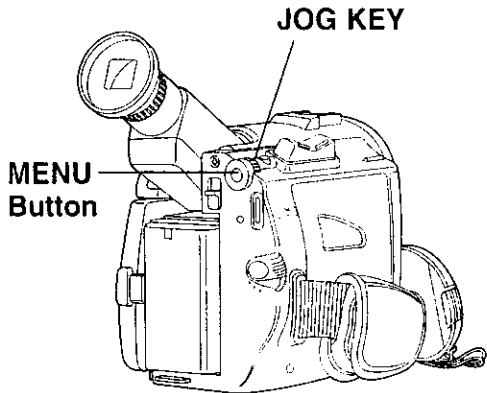

Before you begin...

- Connect the Palmcorder to a power source (pages 10, 11).
- Set POWER to CAMERA or VCR.

1 Press **MENU** to display the Camera or VCR mode menu screen (page 19).

CAMERA MENU

```

CAMERA MENU
1: D.FUNCTION
2: ADJUST
3: REC. MODE
4: SET-UP
5: DISPLAY SETTING
6: LCD SETTING

•SELECT: ROTATE JOG KEY
•SET : PUSH JOG KEY
•EXIT : PUSH MENU KEY
    
```

VCR MENU

```

VCR MENU
1: PLAY FUNCTION
2: REC. MODE
3: PLAY MODE
4: DISPLAY SETTING
5: LCD SETTING

•SELECT: ROTATE JOG KEY
•SET : PUSH JOG KEY
•EXIT : PUSH MENU KEY
    
```

2 Rotate **JOG KEY** to select **5: DISPLAY SETTING**, and then **press JOG KEY** to display the DISPLAY SETTING menu screen.

- DISPLAY SETTING menu is displayed.

3 Rotate **JOG KEY** to select **1: YEAR**, and then **press JOG KEY** to set to ON (pages 20, 22).

- The DATE/TIME SETTING menu appears.

4 Rotate **JOG KEY** to select the desired numbers, then, **press JOG KEY** down to fix that portion and move to the next. Adjust the shaded items for the year, month, day, hour, and minute.

EXAMPLE:

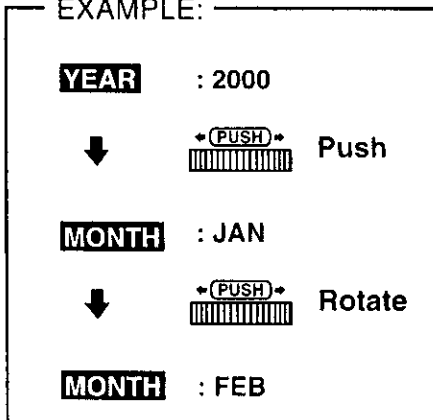

Note

- If you should pass the current year, continue pressing down on the **JOG KEY** until the year appears again.
- A built-in battery maintains clock operation. If the Palmcorder is not connected to a power source for a few months, the built-in battery may discharge and "CLOCK BATTERY" indication appears (page 27).

DATE/TIME SETTING

```

DATE/TIME SETTING
YEAR : 2000
MONTH : OCT
DAY : 18
HOUR : 8PM
MINUTE : 10

•SELECT: PUSH JOG KEY
•SET : ROTATE JOG KEY
•EXIT : PUSH MENU KEY
    
```

When time setting is completed, press the **MENU** to start the clock.

Using the Palmcorder Menu

The Palmcorder features two menu displays: one for CAMERA mode (recording) and the other for VCR mode (Playback) (pages 19~23).

- While the Menu screen is displayed, you cannot record or play the tape.
- While recording, the Menu screen will not be displayed.
- While in playback, the Menu screen can be displayed.

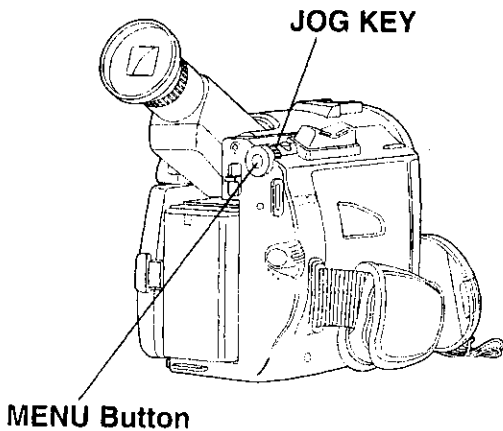

Displaying the MENU

Before you begin...

- Connect the Palmcorder to a power source (pages 10, 11).
- Set POWER to CAMERA or VCR.

1 Press **MENU** to display the CAMERA or VCR menu.

(CAMERA MENU) (VCR MENU)

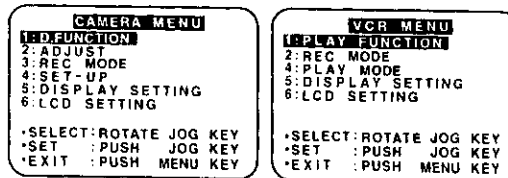

2 Rotate **JOG KEY** select a menu item.

Setting the MENU Items (EX. VCR Mode menu)

1 Press down on the **JOG KEY** to set your selection.

2 Rotate **JOG KEY** to select a menu item.

- The characters of your selection will be inversely displayed.

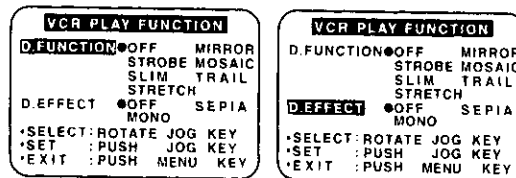

3 Press down on the **JOG KEY** to set your selection.

- The "●" mark will indicate your selection.

4 Press **MENU** twice to exit the menu.

MENU OSD

Camera and VCR main menu

CAMERA MENU

- 1 : D. FUNCTION
- 2 : ADJUST
- 3 : REC MODE
- 4 : SET-UP
- 5 : DISPLAY SETTING
- 6 : LCD SETTING

VCR MENU

- 1 : PLAY FUNCTION
- 2 : REC MODE
- 3 : PLAY MODE
- 4 : DISPLAY SETTING
- 5 : LCD SETTING

CAMERA MENU

1 : D. FUNCTION

CAMERA FUNCTION menu is displayed. To select one of the 9 digital functions (MIRROR, STROBE, MOSAIC, SLIM, TRAIL, STRETCH, GAIN-UP, WIPE, or MIX).

2 : ADJUST

CAMERA ADJUST menu is displayed. To select PROG. AE, W. BALANCE, or H.S.S (High Speed Shutter).

3 : REC MODE

CAMERA REC-MODE menu is displayed. To select REC-SPEED, AUDIO-REC, INDEX, SHUTTER, or SELF-REC.

4 : SET-UP

CAMERA SET-UP menu is displayed. To select REMOTE, TALLY LED, or BEEP.

5 : DISPLAY SETTING

DISPLAY SETTING menu is displayed. To select DISPLAY, C.RESET, DATE/TIME, or CLOCK-SET.

6 : LCD SETTING

LCD SETTING menu is displayed. To select LCD BRIGHTNESS or LCD COLOR.

VCR MENU

1 : PLAY FUNCTION

VCR PLAY FUNCTION menu is displayed. To select D. FUNCTION or D.EFFECT.

2 : REC MODE

VCR REC MODE menu is displayed. To select REC-SPEED.

3 : PLAY MODE

VCR PLAY MODE menu is displayed. To select INDEX, AUDIO, REMOTE, or B.SEARCH.

4 : DISPLAY SETTING

DISPLAY SETTING menu is displayed. To select DISPLAY, C.RESET, DATE/TIME, or CLOCK-SET.

5 : LCD SETTING

LCD SETTING menu is displayed. To select LCD BRIGHTNESS or LCD COLOR.

MENU OSD

Camera Mode Menu Screen

CAMERA FUNCTION
 D. FUNCTION ●OFF MIRROR
 STROBE MOSAIC
 SLIM TRAIL
 STRETCH
 GAIN - UP
 WIPE MIX

CAMERA ADJUST
 PROG. AE ●OFF
 W.BALANCE
 H. S. S ●AUTO SET ●(AUTO)

CAMERA REC MODE
 REC - SPEED ●SP LP
 AUDIO - REC ●12 bit 16 bit
 INDEX ●DAY 2HOUR
 SHUTTER ●OFF ON
 SELF - REC NORMAL ●MIRROR

CAMERA SET-UP
 REMOTE OFF
 TALLY LED ●VCR1 VCR2
 BEEP OFF ●ON ON

DISPLAY SETTING
 DISPLAY OFF MEMORY ●LINEAR
 C.RESET ●OFF T.CODE
 DATE/TIME OFF ON
 CLOCK - SET ●D/T DATE
 OFF ON

LCD SETTING
 LCD BRIGHTNESS
 LOW | | | | HIGH
 LCD COLOR
 LOW | | | | HIGH

Camera Mode Menu Screen

CAMERA FUNCTION

- **DIGITAL FUNCTION** (page 44)
 To select one of the 9 digital functions. Setting to OFF cancels the previously selected digital function.

CAMERA ADJUST

- **PROG. AE** (page 43)
 To select one of the 5 Program AE modes. Setting to OFF cancels the previously selected Program AE mode.
- **W.BALANCE** (page 42)
 To select one of the 3 White Balance modes.
- **H. S. S (High Speed Shutter)** (page 47)
 To select a desired shutter speed.

CAMERA REC MODE

- **REC-SPEED** (page 13)
SP: Normal recording speed mode.
LP: Recording time is 1.5 times as long as in the SP mode. For example, 120 minutes of recording is possible on a 80 minutes tape.
- **AUDIO-REC** (page 48)
12 bit: The sound is recorded in the 12 bit/32 kHz mode.
16 bit: The sound is recorded in the 16 bit/48 kHz high-quality mode.
- **INDEX** (page 37)
DAY: An index signal is recorded when recording is restarted after the date has changed since the last recording.
2 HOUR: An index signal is recorded when recording is restarted after a lapse of more than 2 hours.

- **SHUTTER** (page 41)
When set to ON, still pictures taken in the Photo Shot mode are recorded with a visual shutter effect and click sound.
- **SELF-REC** (page 29)
NORMAL: During self-recording, the picture on the LCD Monitor is the same as it will be recorded.
MIRROR: During self-recording, the picture on the LCD Monitor is horizontally reversed.
- **DATE/TIME** (page 25)
To display the date and time on the screen.
- **CLOCK-SET** (page 17)
When set to ON, the date and time can be set on the screen.

LCD SETTING

- **LCD SETTING** (page 29)
Setting to ON displays the menu for adjusting the LCD brightness and LCD color.

CAMERA SET-UP

- **REMOTE** (page 32)
VCR1: To receive signals from the Remote Control set to VCR1.
VCR2: To receive signals from the Remote Control set to VCR2.
OFF: To prevent reception of signals from the Remote Control.
- **TALLY-LED** (page 28)
Tally LED lights during recording when set to ON.
- **BEEP**
Set to ON to beep when starting and stopping camera recording or when unusual conditions occur. To cancel the beep, set to OFF.
Palmcorder will beep:
 - Once when you start recording
 - Twice when you stop recording
 - Repeatedly when warning of unusual conditions (pages 26, 27).

DISPLAY SETTING

- **DISPLAY** (page 24)
To select the desired type of display and counter indication displayed on the LCD Monitor or in the viewfinder.
- **C.RESET** (page 24)
Setting to ON, resets the counter to zero.

MENU OSD

VCR Mode Menu Screen

VCR PLAY FUNCTION

D. FUNCTION ●OFF MIRROR
 STROBE MOSAIC
 SLIM TRAIL
 STRETCH
 D. EFFECT ●OFF SEPIA
 MONO

VCR REC MODE

REC - SPEED ●SP LP

VCR PLAY MODE

INDEX ●PHOTO SCENE
 AUDIO ●ST1 ST2
 MIX
 REMOTE ●OFF
 ●VCR1 VCR2
 B.SEARCH ●OFF ON

DISPLAY SETTING

DISPLAY OFF ●LINEAR
 MEMORY T.CODE
 C.RESET ●OFF ON
 DATE/TIME ●OFF
 ●D/T DATE
 CLOCK - SET ●OFF ON

LCD SETTING

LCD BRIGHTNESS
 LOW | | | | ----- HIGH
 LCD COLOR
 LOW | | | | ----- HIGH

VCR Mode Menu Screen

VCR PLAY FUNCTION

- **DIGITAL FUNCTION** (page 44)
To select one of the 6 digital functions. Setting to OFF cancels the previously selected digital function.
- **D. EFFECT** (page 44)
To select one of the 2 digital picture effects for playing back. Setting to OFF cancels the previously select digital effect.

VCR REC MODE

- **REC-SPEED** (page 13)
SP: Normal recording speed mode.
LP: Recording time is 1.5 times as long as in the SP mode. For example, 120 minutes of recording is possible on a 80 minutes tape.

VCR PLAY MODE

- **INDEX** (page 37)
To select the desired Index Search function.
- **PHOTO:** To search for PhotoShot pictures.
- **SCENE:** To search for scenes marked with Index signal.
- **AUDIO** (pages 48, 49)
To select the desired audio playback mode after performing audio dubbing in the 12 bit mode.
ST1: The original sound alone is played back.
ST2: The dubbed sound alone is played back.
MIX: The original sound and the dubbed sound are played back together.

- **REMOTE** (page 32)
 - VCR1:**To receive signals from the Remote Control set to VCR1.
 - VCR2:**To receive signals from the Remote Control set to VCR2.
 - OFF:** To prevent reception of signals from the Remote Control.
- **B.SEARCH (Blank Search)** (page 31)
Select ON to go directly to a blank portion of the tape.

DISPLAY SETTING

- **DISPLAY** (page 24)
To select the desired type of display and counter indication displayed on the LCD Monitor or in the viewfinder.
- **C.RESET** (page 24)
Setting to ON, resets the counter to zero.
- **DATE/TIME** (page 25)
To display the date and time on the screen.
- **CLOCK-SET** (page 17)
When set to ON, the date and time can be set on the screen.

LCD SETTING

- **LCD SETTING** (page 29)
Setting to ON displays the menu for adjusting the LCD brightness and LCD color.

Electronic Viewfinder/LCD Monitor Indications

Here are some of the basic indications which will appear on the Palmcorder EVF and LCD Monitor. All indications except, the Date and Time, will NOT be recorded onto the tape.

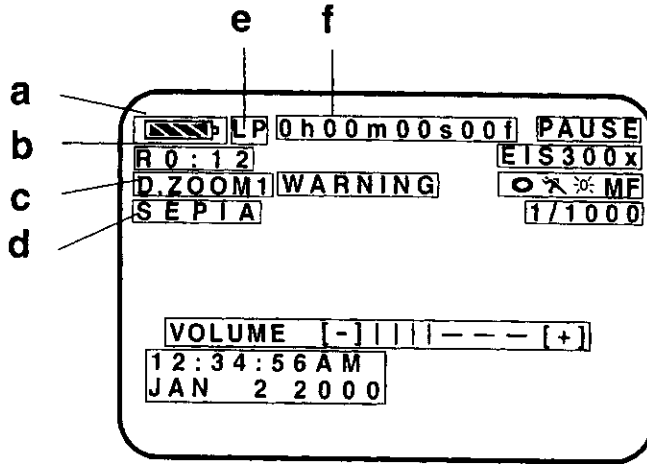

a. Battery Remaining

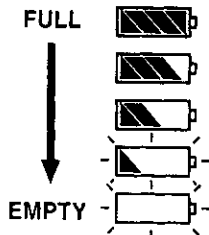

b. Tape Remaining

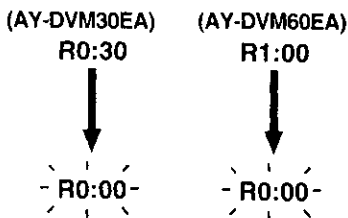

- It will take several seconds for the tape remaining indicator to operate after the tape starts moving.

c. Digital Zoom and other Digital Function (page 40)

This display appears when the digital zoom function has been activated.

d. Playback Effect (page 44)

This display appears when SEPIA or MONO is selected in VCR menu.

e. Tape Speed Indication (page 20)

Indicates the tape speed (SP or LP).

f. Display On/Off and Counter/Time Code

The indication switches as shown below when the desired "DISPLAY" mode is selected from the menu (pages 21, 23).

- When selecting OFF, all displays turned off.

Linear Time Counter Memory Counter

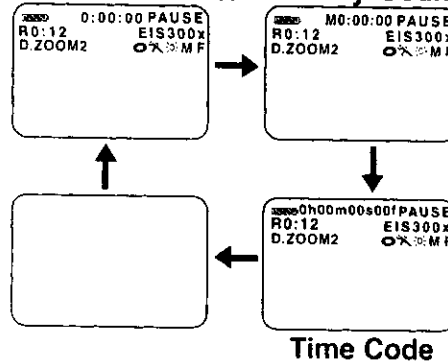

Memory Counter M 0:00:00

The Palmcorder will stop whenever it reaches the point where the counter was previously set to M 0:00:00 during audio dub, fast forward or rewind.

Time Code 0h00m00s00f

The Palmcorder calculates and displays exactly where you are on any tape in terms of hours, minutes, seconds, and frames (30 frames = 1 second).

- This display can not be reset.

IMPORTANT NOTE:

Display must be set to ON for MF, AE, W.BALANCE or BACK LIGHT indications to be displayed on the EVF or LCD Panel when selected.

Electronic Viewfinder/LCD Monitor Indications

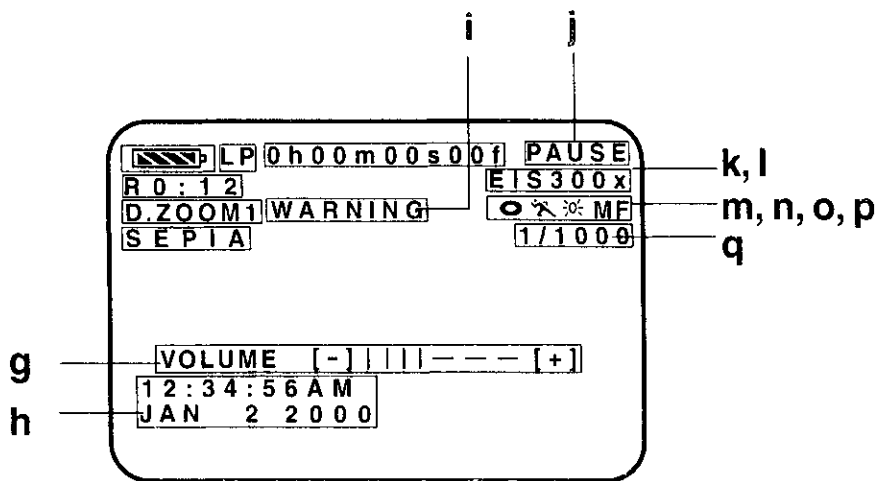

g. Volume Display (page 33)
The volume bar appears when the volume of the built-in speaker is being adjusted.

h. Date and Time Indication
(pages 21, 23)

As shown below, the date and time indication changes each time the DATE/TIME is selected from the Palmcorder's MENU (pages 21, 23) or the DATE/TIME Button is pressed on the remote (optional).

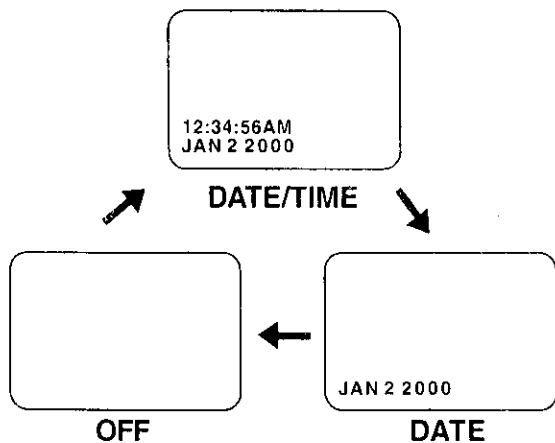

i. WARNING indication (pages 26, 27)
The warning displays appear in the EVF and the LCD monitor.

j. Tape Mode Indications

- REC** Recording.
- PHOTO** PhotoShot Recording.
- PAUSE** Paused during recording.
- PLAY** Playback.
- R ▷** Repeat Playback.
- CHK** Recording Check.
- FF** Fast forward.
- REW** Rewind.
- ▷▷** FF Search.
- ◁◁** REW Search.
- BLANK** Blank Search.
- SEARCH** Index Search.
- Mirror feature recording.
- || Paused during Mirror feature recording.

k. Digital EIS Indications (page 39)

l. Zoom Magnification Level (page 40)

m. Manual Focus Indication (page 45)

n. White Balance Indication (page 42)

o. PROGRAM-AE Indication (page 43)

p. Backlight Indication (page 46)

q. Shutter Mode indication (page 47)

Electronic Viewfinder/LCD Monitor Indications

The following warning displays appear in the EVF and the LCD monitor.

Warning Indications

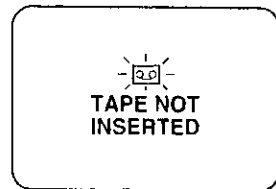

If the Palmcorder is in CAMERA mode without a cassette inserted, " " will flash and "TAPE NOT INSERTED" will appear for 5 seconds. Recording will not start.

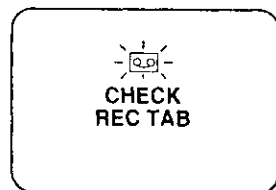

If the Palmcorder is in CAMERA mode with the cassette sliding record tab opened, " " will flash and "CHECK REC TAB" will appear for 5 seconds. Recording will not start.



When Audio dub is performed and the sliding record tab is open, or a blank portion of tape is detected, " " will flash and "CANNOT REC" will appear for 5 seconds.

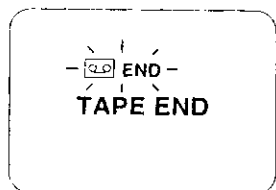

When the tape is about to end in REC mode, " " will flash and "TAPE END" will appear for 5 seconds.



When an incompatible tape is detected, "INCOMPATIBLE TAPE" will appear for 5 seconds.

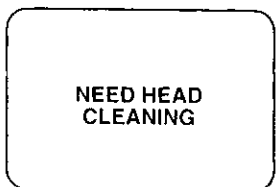

If the video heads require cleaning, "NEED HEAD CLEANING" will appear for 5 seconds.



When the Palmcorder and remote are not set to the same mode (VCR1 or VCR2), "CHECK REMOTE MODE" will also appear for 5 seconds when the Palmcorder is first turned on.

Electronic Viewfinder/LCD Monitor Indications

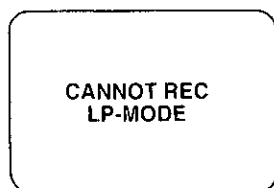

When an AUDIO DUB is attempted on a pre-recorded LP tape, "CANNOT REC LP-MODE" will appear for 5 seconds.

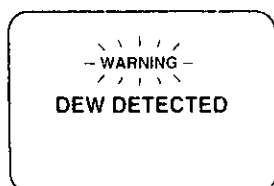

If excessive moisture condenses in the unit, "WARNING" will flash, "DEW DETECTED" will appear, and the Palmcorder will automatically turn OFF in 15 seconds. In this case, wait until the indicator no longer flashes when your Palmcorder is turned on again.

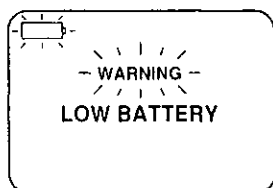

When a battery recharge is necessary, "WARNING" will flash, "LOW BATTERY" will appear, and the Palmcorder will automatically turn OFF in 15 seconds. (page 24).

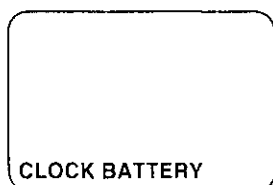

When the built-in lithium clock battery is discharged, "CLOCK BATTERY" will appear. To re-charge the lithium clock battery, connect the AC Adaptor to the Palmcorder. Recharging takes approx. 4 hours. Reset the clock after charging.

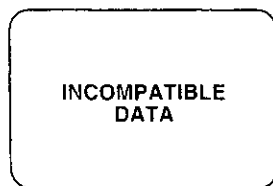

If you play a tape recorded in a format other than NTSC or you try to copy a copy-protected tape, "INCOMPATIBLE DATA" will continuously appear. This message also appears if REC is pressed when DV is input and the copy of copyrighted information is prohibited.

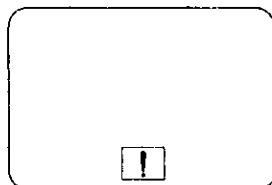

When the LCD monitor is rotated 180° so that it faces the same direction as the lens, the "!" mark indicates that a warning message exists. To view the warning, return the LCD monitor to the original position.

Camera Recording

Simple Recording

Before you begin...

- Connect the Palmcorder to a power source (pages 10, 11).
- Insert a cassette with record tab closed (page 13).

Remove the lens cap and clip it to the hook

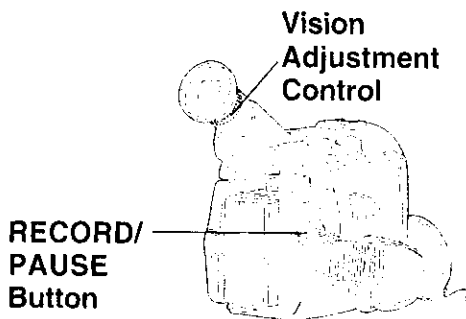
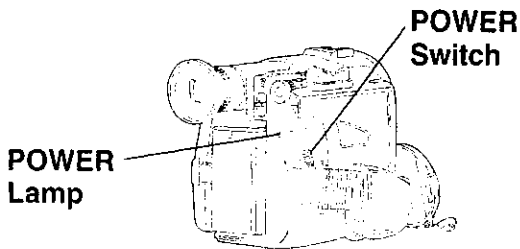
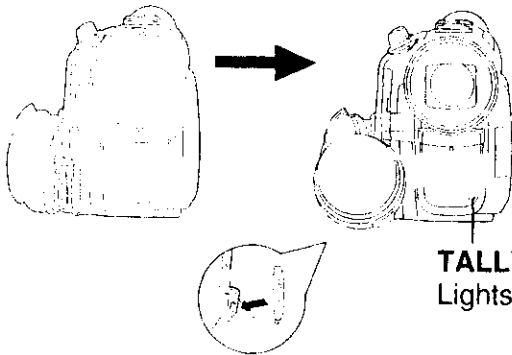

WARNING:

- Do not lift or carry the Palmcorder by the EVF or the LCD Monitor.



1 Set **POWER** to **CAMERA**.

- The POWER lamp lights red.
- Be sure POWER is fully turned to CAMERA position.

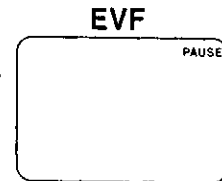

Record/Pause mode.

2 With the Viewfinder Eye Cup up to your eye, adjust the Vision Adjustment Control to your eyesight (page 8).

3 Press **RECORD/PAUSE** to start recording.

The Tally LED will be on.
To turn the Tally LED off, see TALLY LED on page 21.

Press **RECORD/PAUSE** again to pause recording.

- When the Palmcorder is aimed at excessively bright objects, or bright lights, a vertical bar may appear in the picture. This is a normal characteristic of the CCD pick-up device. Try to avoid this whenever possible.

To conserve power

After 5 minutes, the Record/Pause mode will automatically change to Standby mode. To resume recording, set POWER to OFF and then ON again.

Camera Recording

Using the LCD Monitor

The LCD (Liquid Crystal Display) monitor can be used while recording.

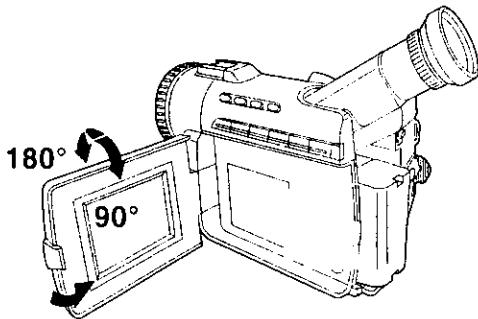
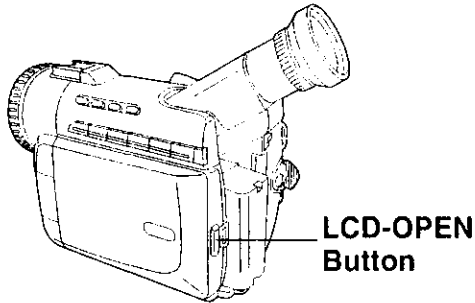

If you adjust the LCD Brightness or color.

- 1 Press **MENU** to display the main menu screen.
- 2 Rotate **JOG KEY** to select from the main menu screen (pages 20, 22).
- 3 Press **JOG KEY** to display the LCD SETTING screen.
- 4 Press **JOG KEY** to select BRIGHTNESS or COLOR, then rotate **JOG KEY** to adjust them.
- 5 Press **MENU** twice to exit this mode.

Before you begin...

- Connect the Palmcorder to a power source (pages 10, 11).
- Insert a cassette with record tab closed (page 13).

1 Press **LCD-OPEN** to unlock the LCD monitor.

2 Swing the LCD monitor fully open and adjust the angle.

- The LCD monitor will automatically turn on.
- When the LCD monitor is completely closed, it will shut off automatically to save power.
- Adjust LCD Brightness and/or color of the LCD monitor if necessary.

3 Start recording (page 28).

Note

- Using the LCD monitor will reduce battery operating time.
- Close the LCD monitor completely when not in use.

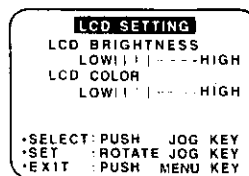

Self Recording

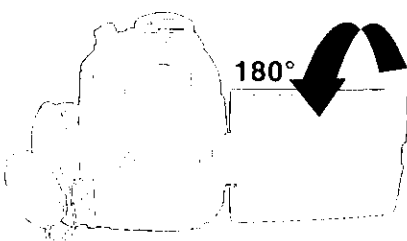

Rotate the LCD monitor 180 degrees so that it faces in the same direction as the lens while in the CAMERA mode to record yourself.

The picture in the LCD monitor will appear reversed.

Set to MIRROR (page 21) on the Camera mode menu screen to see the picture as it is actually being recorded.

Camera Recording

Recording Check

To playback the final few seconds of the last recorded scene in the Recording Pause Mode.

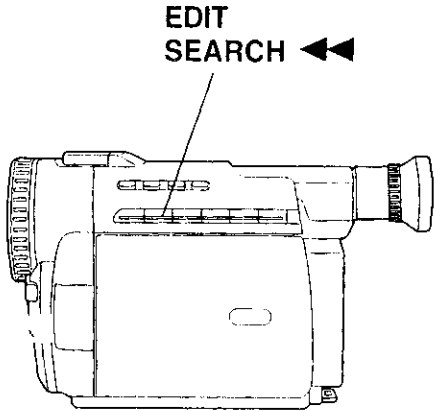

Press **EDIT SEARCH** ◀◀ briefly in the recording Pause Mode.

The [CHK] indication appears. After checking, the Movie Camera returns to the Recording Pause Mode.

- For Recording Check, the Movie Camera must be in the same mode (SP or LP) as used for recording, otherwise the playback picture is distorted.

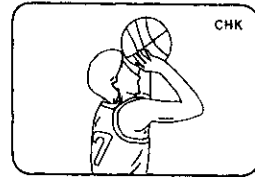

Edit Search

You can visually search for scenes in CAMERA mode to maintain proper continuity when taping.

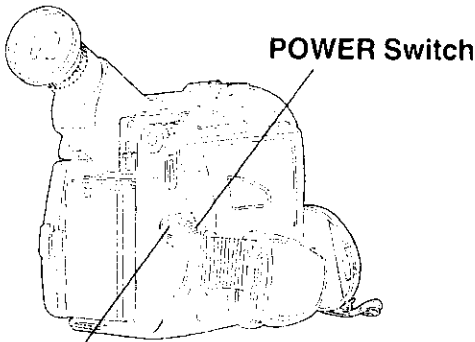

- 1** Set **POWER** to **CAMERA**.
 - The POWER lamp lights red.
 - Be sure POWER is fully turned to CAMERA position.
- 2** In **RECORD/PAUSE** mode, hold down **EDIT SEARCH** ▶▶ to perform a forward visual search or **EDIT SEARCH** ◀◀ to perform a reverse visual search. Releasing the button stops the search.
- 3** Press **RECORD/PAUSE** to continue recording.

Note

- During Edit Search, the picture will have a mosaic pattern. The sound will be muted when using reverse visual search.
- Make sure the SP/LP tape speed setting is the same as the recording to eliminate distortion during edit search.

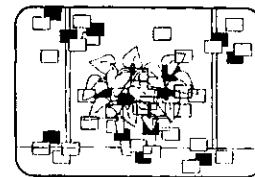

RECORD/PAUSE Button

EDIT SEARCH ◀◀ **EDIT SEARCH** ▶▶

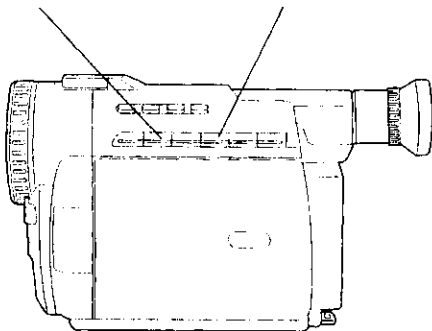

Camera Recording / Remote Control

Blank Search

You can go directly to a blank portion of tape and start recording exactly where you left off.

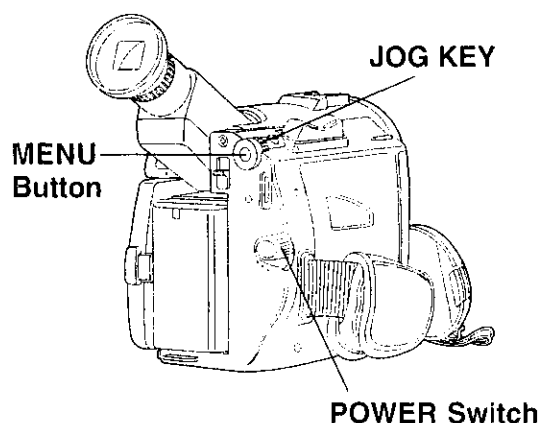

- 1** Set the **POWER** to **VCR**.
 - The **POWER** lamp lights red.
 - Be sure **POWER** is fully turned to **VCR** position.
- 2** Press **MENU** to display the VCR mode menu screen.
- 3** Rotate **JOG KEY** to select **BLANK**, then press **JOG KEY** to display the **VCR PLAY MODE** menu screen.
- 4** Rotate **JOG KEY** to select **ON** in the **VCR PLAY MODE** menu (page 23).
- 5** Press **JOG KEY** to select **ON**.
 - "BLANK" will appear on the screen.

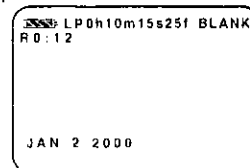

Remote Control (Optional, page 58)

You can operate the major functions of your Palmcorder from up to approximately 16 feet (5 m) away (indoors). Aim the IR Remote Control toward the front of the Palmcorder and press the desired buttons (Remote Sensor is located under the lens).

To operate Camera functions:

Set **POWER** to **CAMERA**.

To operate VCR functions:

Set **POWER** to **VCR**.

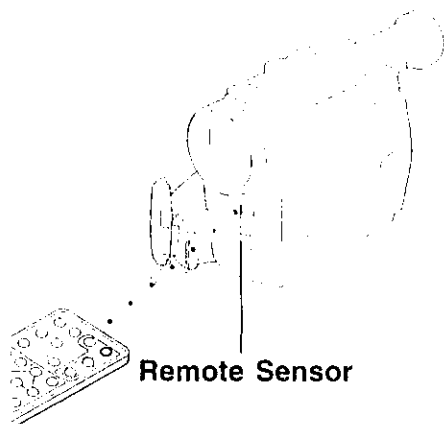

Controlled Functions

- Rec/Pause (page 28)
- Tele (Zoom) (page 40)
- Wide (Zoom) (page 40)
- Date/Time (page 25)
- Reset (page 49)
- PhotoShot (page 41)
- Display On TV (page 38)
- Counter/Time Code (pages 24)
- Audio Dubbing (page 48)
- Record (page 51)
- Menu (page 18)
- Play (page 33)
- FF/Search (page 34)
- REW/Search (page 34)
- Pause/Select (pages 18, 34)
- Stop/Set (pages 18, 33)
- Slow/Frame Advance (Forward) (pages 34, 36)
- Slow/Frame Advance (Backward) (pages 34, 36)
- Index Search (Forward) (page 37)
- Index Search (Backward) (page 37)
- Speaker Volume (page 33)

Remote Control (Optional)

Remote Controlling Two Palmcorders

You can control any two Panasonic Digital Video Camcorder with one Remote control (Optional, page 58). In order for the remote to distinguish between the two units, it is necessary to set one of the Palmcorders to VCR 2. On the remote, press VCR 1 or VCR 2 to control the desired Palmcorder.

Optional

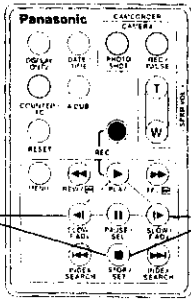

For VCR 2 :
Press these buttons at same time.

For VCR 1 :
Press these buttons at same time.

Note

- When the Palmcorder and remote are not set to the same mode (VCR1 or VCR2), "CHECK REMOTE MODE (REMOTE)" will appear.



- 1** Set the **POWER to VCR or CAMERA.**
 - The POWER lamp lights red.
 - Be sure POWER is fully turned to VCR or CAMERA position.
- 2** Press **MENU** to display the VCR or CAMERA mode menu screen.
- 3** Rotate **JOG KEY** to select [] in the CAMERA mode menu screen or [] in the VCR mode menu screen, then press **JOG KEY** to display the CAMERA SET-UP or VCR PLAY MODE menu screen.
- 4** Rotate **JOG KEY** to select [] and then press JOG KEY to select VCR 2 on one Palmcorder (pages 21, 23). Leave the other Palmcorder set to VCR1.
- 5** Set the Remote Control (Optional, page 58) to VCR 1 or VCR 2 to correspond with the Palmcorder you wish to control. (See illustration at left.)

- After replacing the Remote Control Battery, the remote will default to VCR 1.

Replace the Battery

Optional

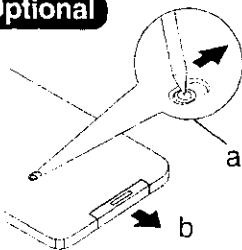

- 1** Insert a slender pointed object, such as the tip of a ball-point pen into the slot so that it fits into the hole (as shown a). Then, while sliding to the right, pull the Battery Tray out with your fingernail.

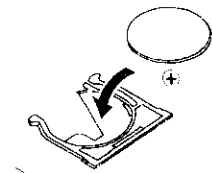

- 2** Insert the battery into the Battery Tray with the ⊕ mark facing down. Do not reverse the polarity.

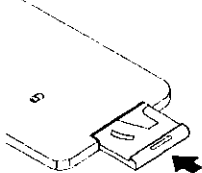

- 3** Insert the Battery Tray.

Replace battery with Panasonic PART NO. VSBW0004 (CR2025) only. Use of another battery may present a risk of fire or explosion. Caution-battery may explode if mistreated. Dispose of used battery promptly. Keep away from children. Do not recharge, disassemble or dispose of in fire.

Playback your Recordings

Playback using the LCD Monitor

You can also use the LCD monitor to playback your recording.

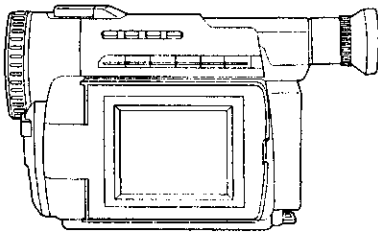
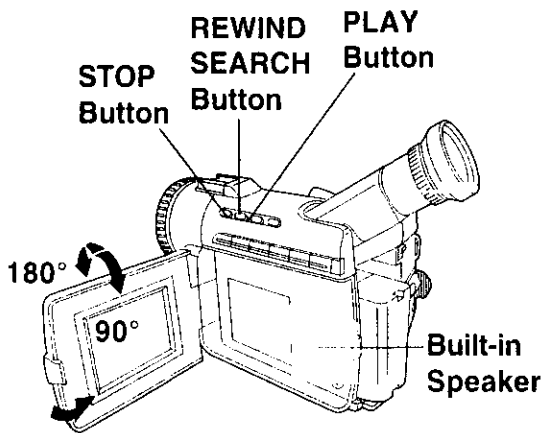
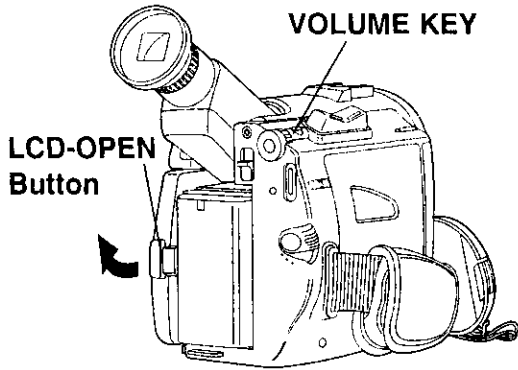

You can place the Palmcorder on a table, etc. for viewing. Rotate the LCD Monitor 180° and swing it up against the Palmcorder body as shown.

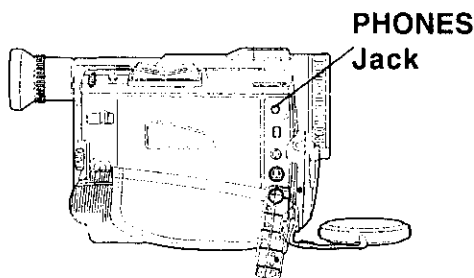

Before you begin...

- Connect the Palmcorder to a power source (pages 10, 11).
- Insert a recorded cassette.
- Set Power to VCR.

1 Press **LCD-OPEN** to unlock the LCD monitor and swing open.

2 Press **REWIND/SEARCH** to rewind the tape.

3 Press **PLAY** to start playback.

To adjust the volume:

Hold down **VOLUME KEY** until the volume setting screen appears (page 25). Then rotate **VOLUME KEY** to adjust the volume of the built-in speaker. To disappear the volume setting screen, hold down **VOLUME KEY** again.

- Adjust the picture on the LCD monitor if needed (page 29).

4 Press **STOP** to stop playback.

- When the tape reaches its beginning during rewind or rewind search, it will stop automatically.
- If you press **PLAY** for more than 5 seconds, the Palmcorder will start the Repeat Playback mode when the tape reaches its end. The letter "R ▷" will appear in the EVF and LCD monitor. To exit the Repeat Playback mode, turn the Palmcorder OFF.



Note

- When a tape recorded in LP mode on another digital video camera is played back on this unit, the picture may appear mosaic.
- Using the LCD monitor reduces battery operating time.
- Connect earphones (not supplied) to the PHONES Jack.

Playback Your Recordings

Special Effect Features During Playback

(Sound is muted during all special effects)

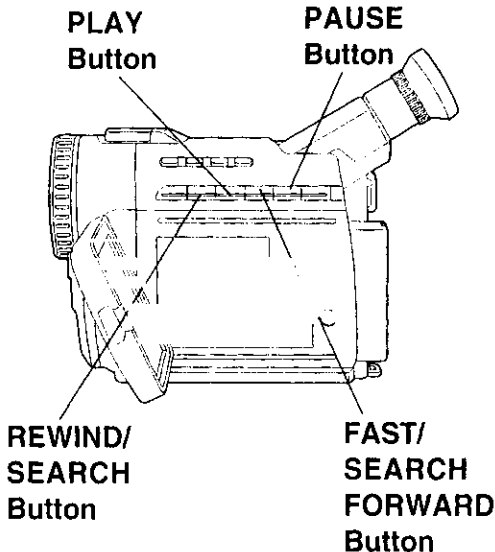

Optional

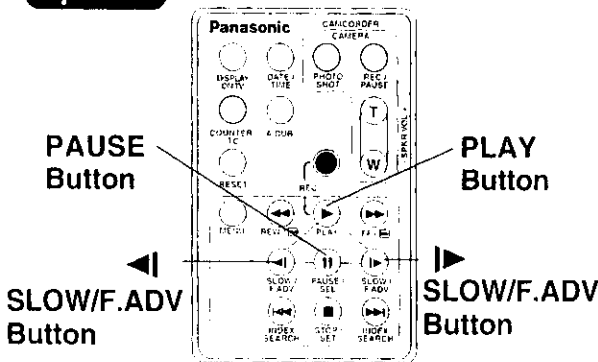

Rapid Visual Search

A During playback, hold down **FAST FORWARD/SEARCH** or **REWIND/SEARCH**.

The search will continue for as long as the button is held down.

OR

B Press **FAST FORWARD/SEARCH** or **REWIND/SEARCH** once for a continuous rapid visual search. Press **PLAY** to release.

Note

- When executing a rapid visual search, the picture may become bluish for an instant or mosaic. This is normal during this mode.



STILL Picture

Press **PAUSE** during playback.

Press **PLAY** or **PAUSE** to release.

Note

- To protect the tape and video heads, your Palmcorder's operating modes will revert as follows:
STILL → STOP (after 5 minutes.)

Slow Motion Playback

Optional Remote Control Only (page 58)

Forward Slow = Press **▶ SLOW/F.ADV** during play.

Reverse Slow = Press **◀ SLOW/F.ADV** during play.

Press **PLAY** to release. (During reverse slow motion playback, time code indication may not change regularly.)

Note

- Palmcorder will automatically STOP when in slow motion for more than 10 minutes.
- During slow motion playback, picture may move up and down. This is normal.
- When you start or stop slow motion playback, the picture may become bluish for an instant.

Playback Your Recordings

Special Effect Features During Playback Continued

(Sound is Muted during all special effects)

PLAY Button

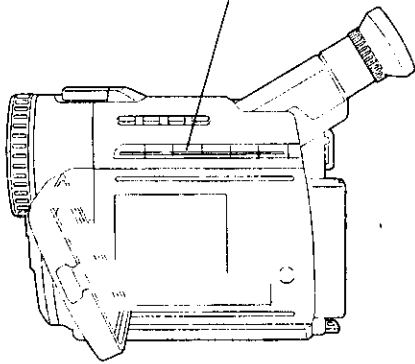

JOG KEY

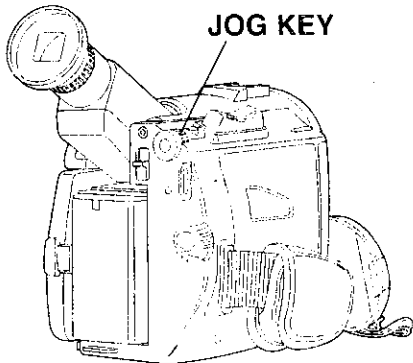

REWIND/SEARCH Button FAST FORWARD/
Button SEARCH Button

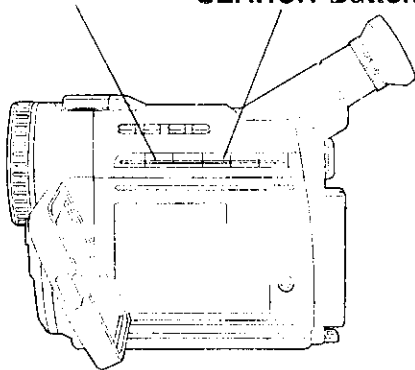

Variable Speed Search

- 1 Press **PLAY** to start playback.
- 2 Press **PLAY** again.
- 3 Rotate the **JOG KEY** to adjust the playback speed.
 - Rotate **JOG KEY** downward for forward playback.
 - Rotate **JOG KEY** upward for reverse playback.

To return to normal playback:

Press **PLAY**. Playback will continue at normal speed.

Note

- The Variable Speed Search function offers a choice of six playback speeds (1/5x, 1x, 2x, 5x, 10x, 20x) both in forward and reverse directions.
- The review playback at the 1x speed is playback in reverse direction.
- During the Variable Speed Search (at a speed other than 1x), mosaic-like patterns will appear in the picture.
- During the Variable Speed Search, sound is muted.

Fast Forward/Rewind Check

Monitor normal picture playback during fast forward or rewind.

- Hold down **FAST FORWARD/SEARCH** during fast forward.
- Hold down **REWIND/SEARCH** during rewind.
- The picture will appear for as long as the button is held down.

Playback Your Recordings

Special Effect Features During Playback Continued

(Sound is Muted during all special effects)

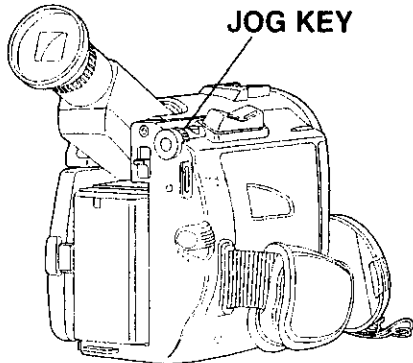
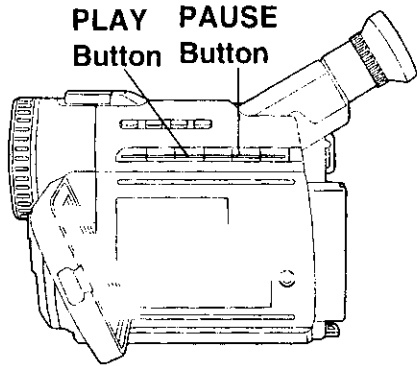

Optional

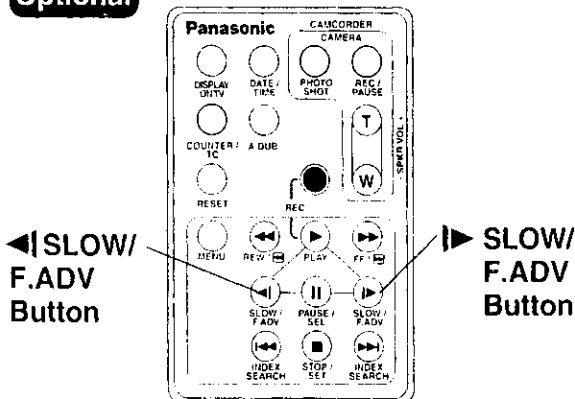

Frame by Frame Advance

Optional Remote Control Only (page 58)

Press **PAUSE** during playback.

Press **▶ SLOW/F.ADV** to do a frame by frame advance.

Press **◀ SLOW/F.ADV** to do a frame by frame reverse.

Press **PLAY** to release.

Note

- If you hold down SLOW/F.ADV, you can see a continuous series of still images at a slower speed than normal slow mode.
- During frame by frame advance, a few frames may move automatically, and the picture may become bluish for an instant.

Jog Frame by Frame Search

(Palmcorder only)

During Still mode, rotate the **JOG KEY** to advance or reverse the picture one frame at a time.

Playback Your Recordings

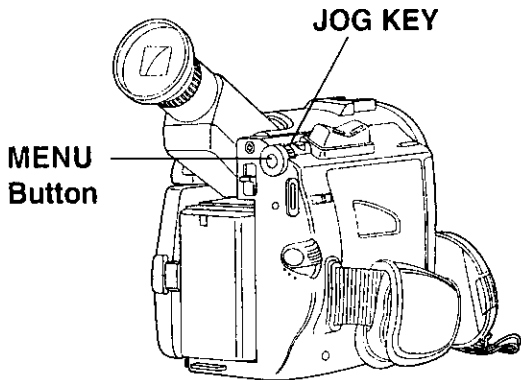

Optional

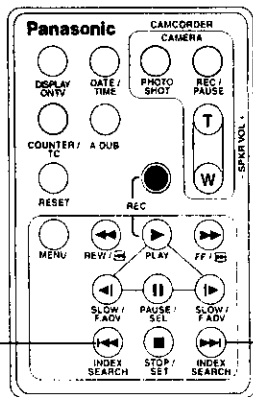

INDEX SEARCH (rewind) Button

INDEX SEARCH (fast forward) Button

Top Scan

If you hold down the **INDEX SEARCH** more than 2 seconds, the Palmcorder will scan for scenes (or PhotoShots) and playback the first few seconds of each.

To cancel this function, press PLAY or STOP.

Index Forward/Reverse Search

Optional Remote Control Only (page 58)

Search for a particular scene by using the electronic index marks placed at the beginning of each recording.

- 1** Set the **POWER** to **VCR**.
 - The **POWER** lamp lights red.
 - Be sure **POWER** is fully turned to **VCR** position.
- 2** Press **MENU** to display the **VCR** mode menu screen.
- 3** Rotate **JOG KEY** to select **PHOTO** or **SCENE**, then press **JOG KEY** to display the **VCR PLAY MODE** menu screen.
- 4** Rotate **JOG KEY** to select **INDEX SEARCH**, and then press **JOG KEY** to select **PHOTO** or **SCENE**.

- 1** Place the Palmcorder in the **VCR STOP** mode.
- 2** Press **INDEX SEARCH fast forward** or **rewind** the number of recordings (indexes) forward or back you want to view. The Palmcorder will advance or rewind to the desired recording and automatically **PLAY**.
 - The number of times you pressed the button is displayed in the **EVF** and the **LCD** monitor if you set **INDEX** on the **VCR** menu to **SCENE** (page 22). (Ex., if you press the button three times, "S3" will appear.)
 - If the interval between scenes is less than 1 minute, index search may not operate properly.
 - Response time between pressing the button and change in the scene number is quite slow. Do not press the **INDEX SEARCH** rapidly and continuously.
 - It won't playback when the tape reached beginning playback during Reverse Index Search mode.

Playback Your Recordings

Connections

TV with AUDIO/VIDEO IN Jacks.

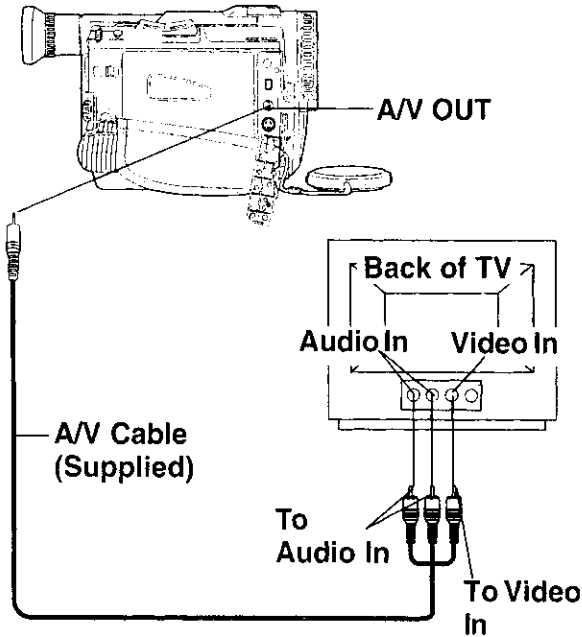

TV with S-VIDEO IN Jacks.

For best Chrominance and Luminance, it is suggested to use the S-Video connection if available on your TV.

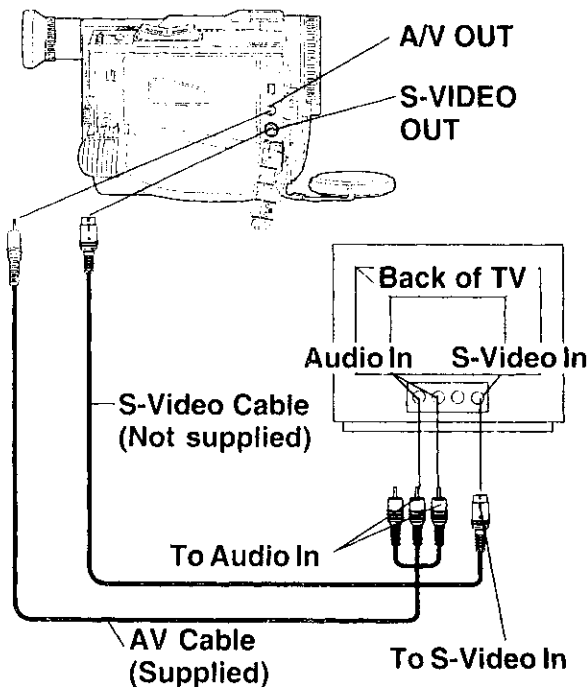

- 1** Set **POWER** to **CAMERA**.
You can now view what the Palmcorder is recording on your TV.
Or, to playback a tape, set POWER to VCR.
You can now playback a recorded tape on your TV.
- 2** Turn your TV **ON** and set it to **LINE INPUT** or **S-VIDEO**.
Check your TV operating instructions for further information.
- 3** Start playback or begin a recording.

Note

- Please fully connect the A/V cable to both the camcorder and the TV.
- Make sure the Palmcorder and TV are turned off while connecting.

Optional Remote Control Only (page 58)

You can display the various EVF and LCD indications on your TV by pressing **DISPLAY ON TV** on remote control. Press again to remove the indications.

DISPLAY ON TV Button

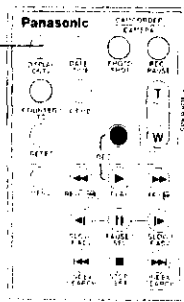

Optional

CATV System Installer

This reminder is provided to call the CATV system installer's attention to Article 820-40 of the NEC in USA (and to the Canadian Electrical code in Canada) that provides guidelines for proper grounding and, in particular, specifies that the cable ground shall be connected to the grounding system of the building, as close to the point of cable entry as practical.

Special Features

Dual Digital Electronic Image Stabilization System (D.E.I.S.)

The feature helps to compensate for any unintentional hand or body movement. It can be used in both the Recording and Playback (VCR) modes.

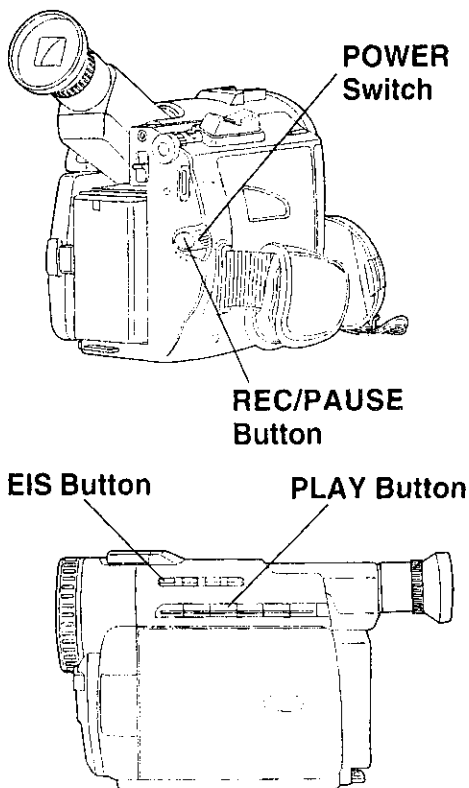
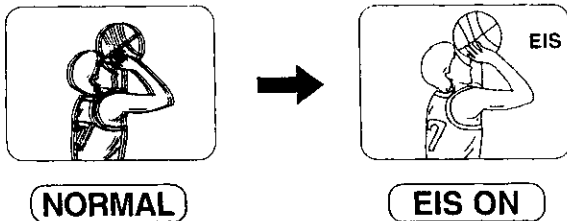

Note

- Digital Functions are turned off automatically when the EIS and Digital Zoom are selected.

Camera mode

- 1** Set **POWER** to **CAMERA**.
 - The POWER lamp lights red.
 - Be sure POWER is fully turned to CAMERA position.
- 2** Press **EIS** to stabilize the picture.
 - Picture flicker may be observed when taping under fluorescent lighting conditions.
 - The EIS indicator flashes when the light level is inadequate.
 - Turn D.E.I.S. OFF during recording when using a tripod.
- 3** Press **REC/PAUSE** to start recording.
- 4** Press **EIS** again to cancel.
 - Be sure that D.E.I.S. is turned off when not needed.

D.E.I.S. may not function when...

- Palmcorder movement is too extreme.
- Recording a subject with distinct horizontal or vertical stripes.
- Recording in low light situations.
- Recording a subject under a great amount of fluorescent light.
- Recording a scene with very fast motions.

VCR mode

- 1** Set **POWER Switch** to **VCR**.
 - The POWER lamp lights red.
 - Be sure POWER is fully turned to VCR position.
- 2** Press **PLAY** to start playback.
- 3** Press **EIS** to stabilize the picture.
- 4** Press **EIS Button** again to cancel.
 - Be sure that D.E.I.S. is turned off when not needed.

Note

- When using D.E.I.S. in VCR mode, the size of the scene may appear slightly larger.

Special Features

Zoom

You can gradually zoom in for close ups or zoom out for wide angle shots.

Zoom slowly : By lightly pressing the "T" (Telephoto) or the "W" (Wide Angle) side of the POWER ZOOM Switch.

Zoom quickly : By applying more pressure.

Note

The zooming speed ranges from a slow 22 seconds to a fast 2 seconds according to the amount of pressure applied to the POWER ZOOM Switch.

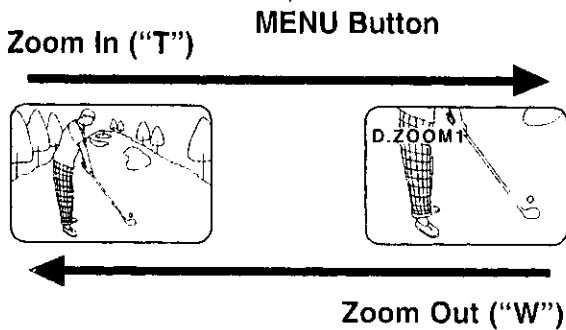
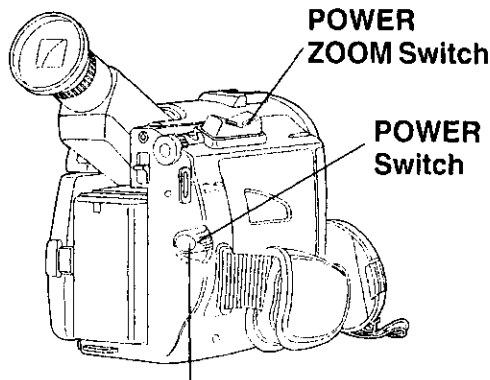

Note

- Digital Functions are turned off automatically when the EIS and Digital Zoom are selected.

Digital Zoom

Camera mode

- 1 Set POWER to CAMERA.**
 - The POWER lamp lights red.
 - Be sure POWER is fully turned to CAMERA position.
- 2 Press D. ZOOM** to select D.ZOOM1 or D.ZOOM2.
 - once** : D.ZOOM1 (from 18x to 36x)
 - twice** : D.ZOOM2 (from 18x to 300x)
 - three times** : Turn off D.ZOOM
- 3 Press REC/PAUSE** to start recording and press **POWER ZOOM** to zoom in or zoom out.
 - The magnification level is always displayed in the EVF or the LCD monitor when DISPLAY is set to ON (pages 21, 23)
- 4 Press D.ZOOM** to turn off Digital Zoom so that no indication appears.

Note

- The normal optical zoom functions from 1x to 18x.
- Because the image is enlarged digitally, the picture may become distorted when higher magnification levels are used.
- When the level falls below 18x, the normal zooming function will resume.
- Focus distance becomes 4 feet (1.2m) if the lens is in full telephoto.

VCR mode

- 1 Set POWER to VCR.**
 - The POWER lamp lights red.
 - Be sure POWER is fully turned to VCR position.
- 2 Press PLAY** to start playback.
- 3 Press D.ZOOM.**
 - The center portion of the image doubles in size.
- 4 Press D.ZOOM** again for normal image size.

Special Features

Digital PhotoShot

Use this feature to record a seven second (approx.) still image from the current camera picture. Audio is also recorded for on the spot narration. Or, you can add narration later with the Audio Dubbing feature to make an interesting slide show, etc. (page 48).

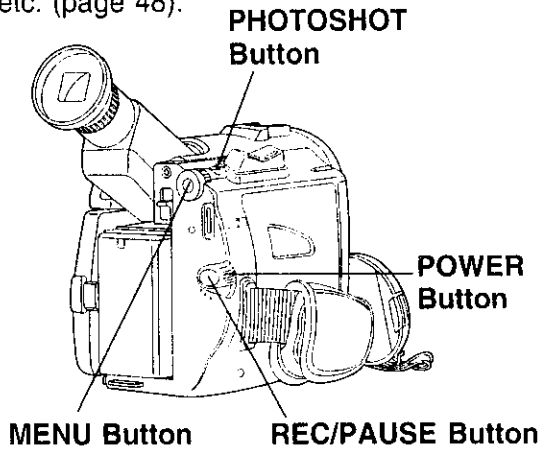

Before you begin...

- Set POWER to CAMERA.

- 1 Press **PHOTOSHOT** in Record/Pause mode. "PHOTO" will appear in the EVF or the LCD monitor.

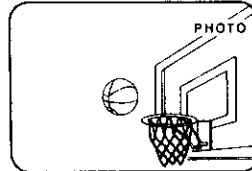

- If SHUTTER on the menu screen is set to ON, a sound effect similar to the shutter of a film camera will be heard when the **PHOTOSHOT** is pressed.
- The Tally Lamp and REC Lamp will be on.
- When **PHOTOSHOT** is pressed, the playback image will take approximately 7 seconds to process. After that, the Camera mode screen will be displayed.

Index Search (Photo/Scene)

Optional Remote Control Only (page 58)

Optional

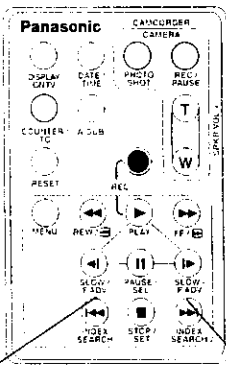

INDEX SEARCH
(rewind Button)

INDEX SEARCH
(fast forward Button)

Note

- The picture quality will deteriorate slightly.
- The tape remaining indicator will not appear while **PHOTOSHOT** feature is used.
- In the Photo/Scene Index Search mode, the shutter sound effect may not be able to be heard even when SHUTTER is set to on.
- Photo Index Search may fail to detect a recorded PhotoShot image if the image is 3 seconds or less.

- 1 Set **POWER** to **VCR**.
 - The POWER lamp lights red.
 - Be sure POWER is fully turned to VCR position.
- 2 Press **MENU** to display the VCR mode menu screen.
- 3 Rotate **JOG KEY** to select **PLAY**, and press **JOG KEY** to display the VCR PLAY MODE menu screen.
- 4 Rotate **JOG KEY** to select **PHOTO** or **SCENE**, and press **JOG KEY** to select **PHOTO** or **SCENE**.
- 5 Press **INDEX SEARCH** fast forward or rewind on the remote control (Optional, page 58) to advance or rewind the tape to playback a PhotoShot scene. To view the next PhotoShot, **INDEX SEARCH** must be pressed again.

Special Features

White Balance

Auto White Balance automatically maintains optimum color balance in most lighting conditions. However, when using Digital Functions, etc., you may get better results using the manual adjustment.

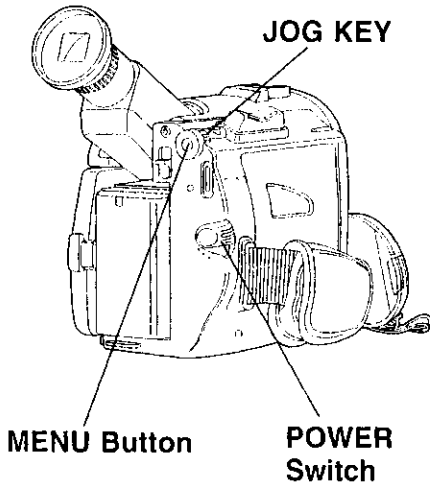

- 1** Set **POWER** to **CAMERA**.
 - The **POWER** lamp lights red.
 - Be sure **POWER** is fully turned to **CAMERA** position.
- 2** Press **MENU** to display the menu screen.
- 3** Press **JOG KEY** to select and then press **JOG KEY** to display the **CAMERA ADJUST** menu screen.
- 4** Rotate **JOG KEY** to select and then press down on **JOG KEY** repeatedly to select either **AUTO**, Indoor halogen lamp "☀", Outdoors "☀".

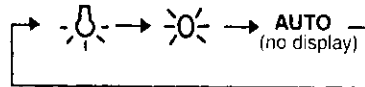

- ☀ : When the source illumination is a halogen lamp.
- ☀ : When shooting outdoors on a sunny day.
- AUTO** : Automatically maintains optimum color balance in most lighting conditions.

Recording Still Pictures

You can record still pictures of any desired duration together with sound.

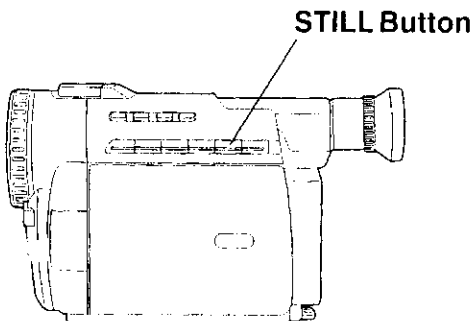

- 1** While in **RECORD** mode, press **STILL** and hold for **2 seconds** to capture still picture. The captured still picture will be recorded together with the sound.
- 2** Press **STILL** once again to release the still picture. The camera will resume recording real-time pictures.

Special Features

Program AE

The Auto Exposure feature can be used to make quality recordings in a variety of scene situations.

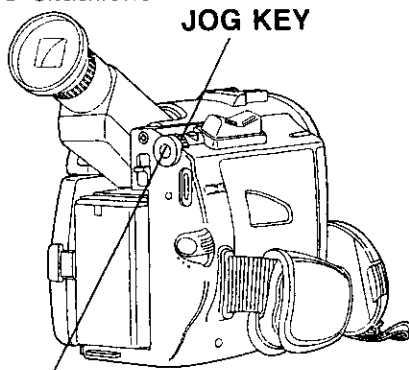

MENU Button

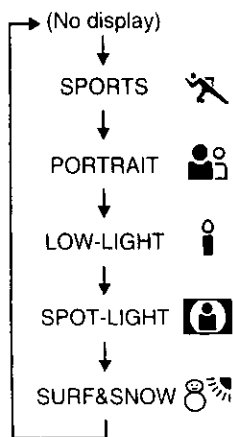

Note

SPORTS mode

- The recorded images will not be so blurred when they are viewed later using slow or still picture playback.
- When playing back a sports mode recording, the movement may appear slightly jerky.
- Do not use this mode when recording under fluorescent, mercury or sodium lighting. These types of lights will affect the color and brightness of the images.
- A vertical band of light might appear when recording objects that are brightly illuminated or which are highly reflective.
- If the amount of light is insufficient, the SPORTS "X" indicator will flash in the EVF or the LCD monitor.
- The image may flicker if this mode is used indoors.

1

Set **POWER** to **CAMERA**.

- The POWER lamp lights red.
- Be sure POWER is fully turned to CAMERA position.

2

Press **MENU** to display the menu screen.

3

Press **JOG KEY** to select **PROGRAM**, and then press **JOG KEY** to display the CAMERA ADJUST menu screen.

4

Rotate **JOG KEY** to select **SPORTS**, and then press **JOG KEY** to select one of the five modes shown below.

5

Repeat steps 4~5 to select OFF to cancel this feature.

- **Sports mode** For recording fast action scenes.
- **Portrait mode** For recording only subjects in the foreground, while ignoring subjects in the background.
- **Low-light mode** For recording in extreme low light conditions.
- **Spot-light mode** Recording in situations where subjects are under a spotlight(s).
- **Surf & Snow mode** For recording in locations with a high degree of "Dazzle", such as snow slopes and the seashore.

PORTRAIT mode

- The image may flicker if this mode is used indoors.

LOW-LIGHT mode

- Scenes recorded in extremely low light levels may not come out properly.

SPOT-LIGHT mode

- If the recorded subject is extremely bright, the picture may appear whitish.

SURF&SNOW mode

- If the recorded subject is extremely bright, the picture may appear whitish.
- It is not possible to select the SPORTS mode and PORTRAIT mode together with the GAIN UP in the Digital function camera menu.

Special Features

Other Digital Functions

Use the following features to add interest and professionalism to your recordings or playback. Select from eleven special effects.

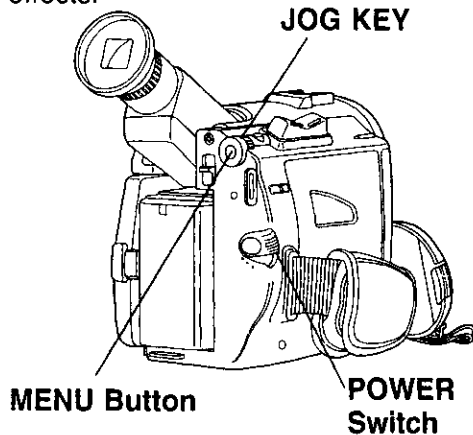

Types of Digital Function

MIRROR

Symmetrical image from the current camera picture.

STROBE

The recording appears as a sequence of still frames.

MOSAIC

The picture appears in a mosaic pattern.

SLIM

The picture is expanded vertically.

TRAIL

The subject being recorded creates a trail when in motion.

STRETCH

The picture is expanded horizontally.

GAIN UP (Not available during playback)

Picture sensitivity is increased.

- Only Manual Focus is available.

WIPE

Successive scenes are separated in a way which simulates the drawing of a curtain.

MIX

The current scene is mixed in with the following scene during scene changes.

SEPIA (Only available during playback)

The picture is played back in sepia, brownish color, giving it an antique look.

MONO (Monotone) (Only available during playback)

The picture is played back in black-and-white.

- 1** Set **POWER** to **CAMERA** or **VCR**.
 - The **POWER** lamp lights red.
 - Be sure **POWER** is fully turned to **CAMERA** or **VCR** position.
- 2** Press **MENU** to display the menu screen.
- 3** Press **JOG KEY** to select **D.FUNCTION** in the **CAMERA** mode menu screen or **PLAYFUNCTION** in the **VCR** mode menu screen, then press **JOG KEY** to display the **CAMERA FUNCTION** or **VCR PLAY FUNCTION** menu screen.
- 3** Rotate **JOG KEY** to select **D.FUNCTION**, and then press **JOG KEY** repeatedly to select one of the Digital Function listed at the left.
- 4** To cancel the Digital Function, press down on **JOG KEY** to select **OFF**.

Note

- The **EIS** and **Digital Zoom** features are turned off automatically when one of the Digital Functions listed at left is selected.
- Refer to the Types of Digital Effects at the left.

To use the WIPE function:

- a. In Camera mode, set the "D.FUNCTION" item in the main menu screen to "WIPE" (page 20).
- b. Press **RECORD/PAUSE** to start recording.
- c. Press **RECORD/PAUSE** to pause the recording. The last scene will be memorized.
- d. Press **RECORD/PAUSE** to start recording again. The new scene will take the place of the memorized scene.

To use the MIX function:

- a. In Camera mode, set the "D.FUNCTION" item in the main menu screen to "MIX" (page 20). Then, perform steps b-d above.

The memorized scene and the new scene will appear mixed as the scene changes from one to the other.

Special Features

Auto Focus

The Palmcorder automatically adjusts the focus over the entire zoom range.

Manual Focus

Use Manual Focus (MF) when recording ...

- a subject through glass.
- a scene where the subject is far from the Palmcorder and there are objects in the foreground.
- a subject with distinct horizontal stripes.
- a subject not centered in the Viewfinder.
- subjects with shiny surfaces.
- an obliquely angled subject.
- a bright, flat subject such as a white wall.
- in low light situations.
- a scene with fast motions, like a golf swing.

• **Re-focusing may be required** when your Palmcorder is aimed at a new scene.

1 Press **MANUAL FOCUS control wheel** so that "MF" (Manual Focus) appears in the EVF or the LCD monitor.

POWER ZOOM Button

MANUAL FOCUS control wheel

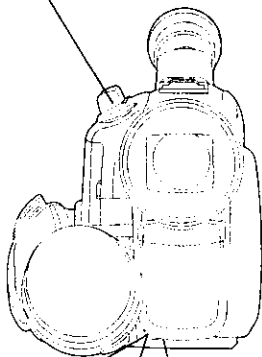

Rotate **2** **1** Press

EVF/LCD Monitor



2 Press and hold **POWER ZOOM** to the "T" side (**Full Telephoto**) until the lens is zoomed in all the way (subject at maximum size).

3 Turn **MANUAL FOCUS control wheel** until the picture is in focus.

- It may be necessary to back away from the subject to focus the image properly.

4 Press **POWER ZOOM** to "W" or "T" as desired.

- The subject will remain in focus over the entire zooming range.
- It may be necessary to back away from the subject to focus the image properly.

Macro Focus (for close-ups)

Press the "W" side of **POWER ZOOM** to the wide angle position.

Auto Focus will function with the subject as close as 1 inch (25mm) in front of the lens.

Special Features

Audio/Video Fade In/Out

This feature allows you to make smoother scene transitions for a more professional look.

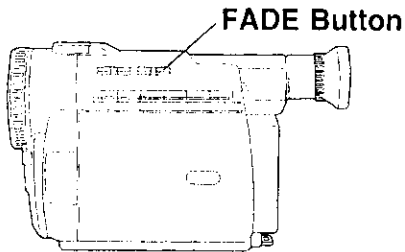

Fade In:

Starting the first scene with "fade in" is very effective.

In Record/Pause mode, hold down **FADE** until the picture fade out.

Then, press **RECORD/PAUSE** to start recording.

Release **FADE** and the picture will gradually fade in.

Fade Out:

Use to create a soft ending or (together with fade in) for a soft transition from one scene to the next.

During recording, hold down **FADE** until the picture fade out.

Then, press **RECORD/PAUSE** to pause the recording.

REC/PAUSE Button

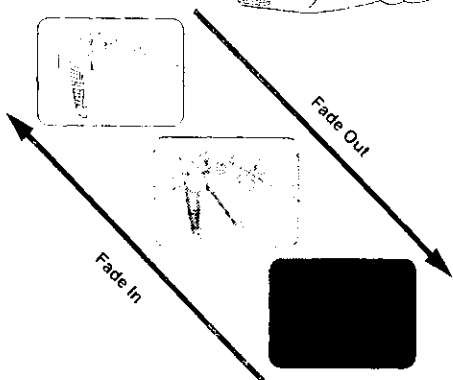
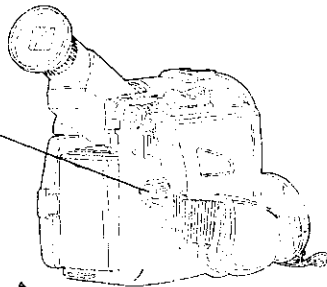

Backlight

Use when recording a subject that is darker than the surrounding scene, in a shadowed area, or when the light source is in the back of your subject.

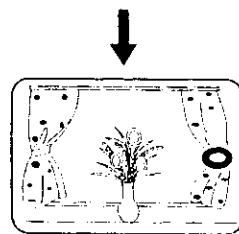

EVF or LCD monitor indication.

Press **BACK LIGHT** to activate the Backlight feature.

The Indicator "●" will appear in the EVF or LCD monitor.

Press **BACK LIGHT** again to cancel the Backlight feature.

BACK LIGHT Button

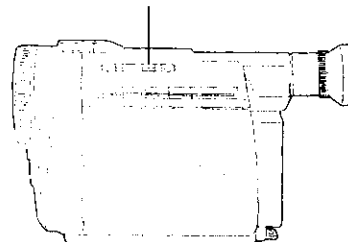

Note

- The Indicator "●" will not appear in the EVF or LCD monitor when OFF is selected in the DISPLAY menu.

Special Features

High Speed Shutter

To record high speed motion (e.g. tennis stroke) for improved STILL or SLOW MOTION playback, when watching the tape on this Camcorder.

Before you begin...

- Connect the Camcorder to a power source (pages 10, 11).
- Set POWER Switch to CAMERA.
- Insert a cassette with record tab (page 13).

Auto Shutter

In the AUTO mode (no indication in the EVF) and LCD monitor, the Camcorder will automatically adjust the shutter speed (up to 1/350).

- AUTO mode is automatically selected whenever the POWER Switch is set to CAMERA.

Manual Selection

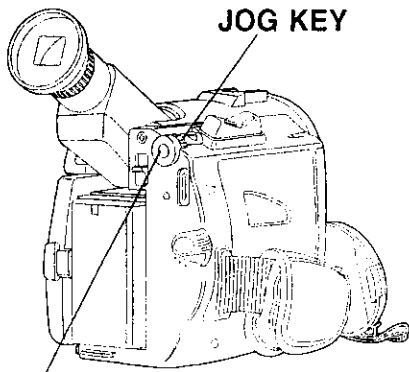

MENU Button

- 1 Press **MENU** to display the camera mode menu in the EVF or the LCD monitor.
- 2 Rotate and press **JOG KEY** to select **SHUTTER SPEED** menu, and then rotate and press **JOG KEY** to select **SHUTTER SPEED** menu is displayed.

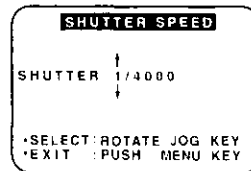

Note

- For proper color reproduction, it is recommended that you use this feature outdoors. For indoor High Speed Shutter recording, additional halogen or tungsten light should be provided. Fluorescent light will degrade the picture quality.
- This feature requires ample light. More light is required for the fastest shutter speeds.
- The Auto Focus system may not operate properly in insufficient light when using the High Speed Shutter.
- When PROG.AE is ON, you cannot manually select the shutter speed.

- 3 Rotate **JOG KEY** to obtain one of the following shutter speeds.

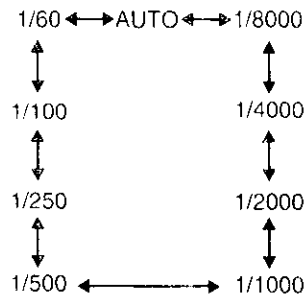

Special Features

Audio Dubbing using the External or Built-in Microphone

The original sound can be replaced with new sound using the built-in Palmcorder microphone or an external microphone.

External Microphone with M3 connector (not supplied)

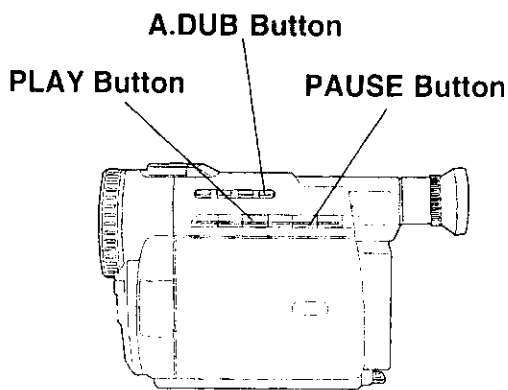
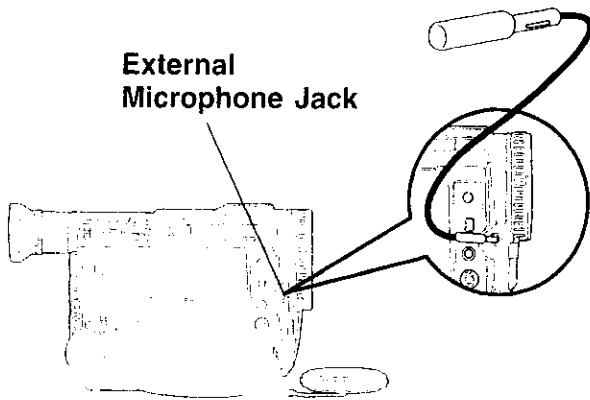

Optional

A.DUB Button

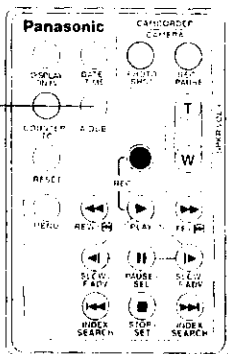

Before you begin...

- Connect the external Microphone (if used).
- Turn On the Palmcorder.
- Insert a pre-recorded tape to be dubbed.

The AUDIO-REC setting in CAMERA MENU mode should be as follows:

12 bit The original sound is recorded on S (Stereo) 1, and the new sound will be recorded on ST (Stereo) 2.

16 bit The original sound is replaced with the new sound.

- Select 12 bit if you do not want the original sound to be completely replaced during an audio dub.
- If you dub over a tape which has both 12 bit and 16 bit audio recordings on it, keep in mind that the original 16 bit audio portion will be completely replaced.

1 Set **POWER** to **VCR**.

- The **POWER** lamp lights red.
- Be sure **POWER** is fully turned to **VCR** position.

2 Press **PLAY**.

Then press **PAUSE** where you want dubbing to begin.

3 Press **A.DUB** on this unit (for three seconds) or the remote control (optional, page 58) to put the Palmcorder in the Audio Dub mode.

- "A.DUB" flashes in the EVF or the LCD monitor.

EVF/LCD Indication

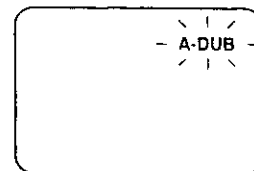

(Continued on next page.)

Special Features

PAUSE Button

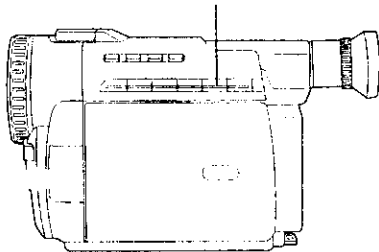

To listen to the desired audio sound, set the AUDIO setting of the VCR mode MENU (page 22) as follows:

AUDIO (The following selections are available for 12 bit AUDIO dubbed recording only)

ST 1 Set this position to listen to the original sound.

ST 2 Set this position to listen to the audio dubbed sound.

MIX Set this position to listen to both the original sound and the audio dubbed sound.

Note

- 16 bit dubbed sound completely erases the original 16 bit recorded sound.
- If you select 12 bit AUDIO recording and dubbed the sound with the AUDIO-MIX on, the sound will be stereo regardless of the AUDIO-OUT setting.
- If you recorded in LP mode, you can not use the A-DUB feature.

Memory-Stop Editing (Optional Remote Control Only, page 58)

You can set an automatic Edit stopping point.

Optional

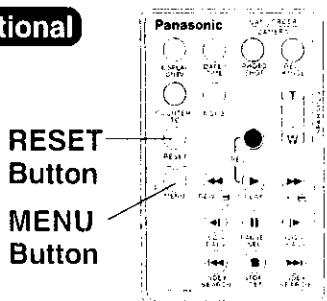

- 4** Press **PAUSE** to start Audio Dubbing.
- Connect Palmcorder to TV in order to monitor the sound (page 38).

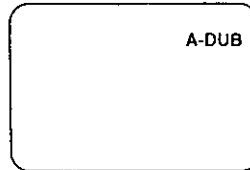

Only NTSC (National Television Standards Committee) recorded tapes can be audio dubbed. The following screen appears if the tape was not recorded in NTSC format.

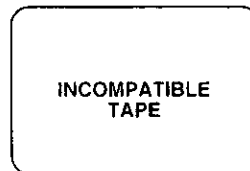

- 5** Press **PAUSE** to stop Audio Dubbing.

- If the microphone used for dubbing gets too near the speaker of your TV, a howling noise (feedback) may occur.
- If the tape position lies or starts in a blank section, you can not use the A-DUB feature.

Before step 2, locate the point at which you want the dubbing to stop.

Press **MENU** to display the VCR menu screen.

Rotate **JOG KEY** to select [] and then press **JOG KEY** to display the DISPLAY SETTING menu.

Rotate **JOG KEY** to select [] and then press **JOG KEY** to set to MEMORY.

Then, press **RESET** on the remote control to reset the Counter Memory to M 0:00:00.

Now, rewind to the editing start point, and continue with steps 2-5. The tape will now stop automatically at "M 0:00:00".

Special Features

Copying your Tapes to S-VHS or VHS Cassette

Source
(Playing)
Palmcorder

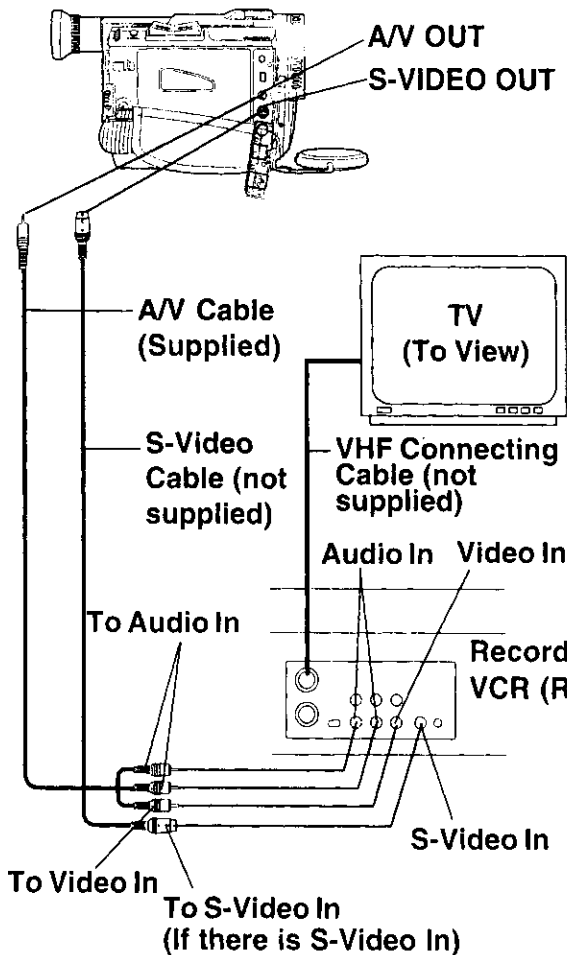

Monitor with your TV

- Turn the TV ON and select its VCR channel (either CH3 or CH4).
- Set the VCR/TV Selector on the recording VCR to VCR.

Before you begin...

- Connect both Palmcorder and VCR to their power sources.
- Connect the Palmcorder to a VCR as illustrated below.
- Turn ON both units.
- **Set the recording VCR's Input Signal Selector to LINE.**
- Set the Palmcorder POWER Switch to VCR.

- 1** Insert a pre-recorded tape into the source (playing) Palmcorder and a blank tape with record tab in place into the target VCR (Recorder).
 - 2** Press **PLAY** on the Palmcorder. When the tape reaches the point you want to start dubbing, press **PAUSE**.
 - 3** Press **REC** or simultaneously **REC** and **PLAY** (depends on VCR) and then pause the recorder.
-
- VCR Buttons**
- 4** Simultaneously, press **PAUSE** on both units to begin the copying.
 - 5** Press **STOP** on both units when copying is completed.

Note

- For technical reasons, dubbing a tape may reduce its quality.
- Press **DISPLAY** on the Palmcorder remote control (optional, page 58) to eliminate EVF/LCD Monitor indications to be recorded on the tape.
- If the Time Code is displayed in the EVF or LCD monitor, this display cannot be reset.

CAUTION:

Unauthorized exchanging and/or copying of copyrighted recordings may be copyright infringement.

Special Features

Copying from Digital Equipment (dubbing)

High quality digital-to-digital copying can be accomplished if both Palmcorders incorporate the digital in/out IEEE 1394 interface (DV interface cable is not supplied).

Source
(Playing)
Palmcorder

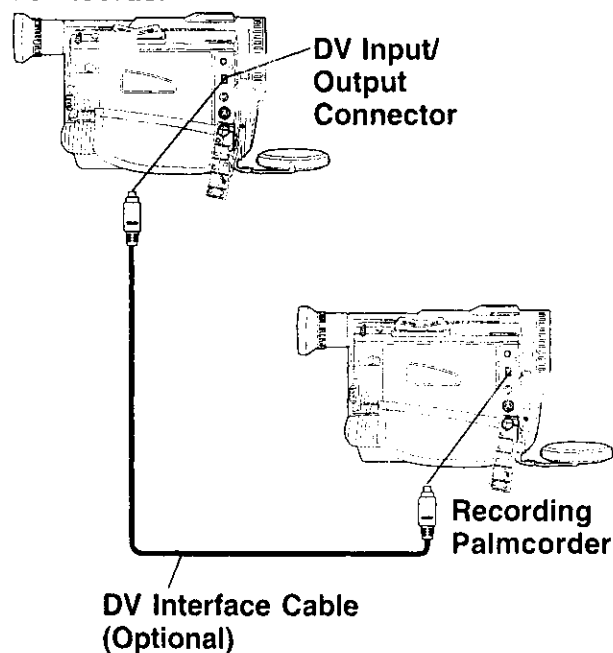

STOP Button PLAY Button PAUSE Button REC Button

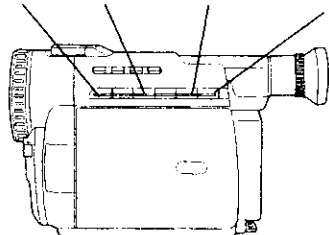

Optional

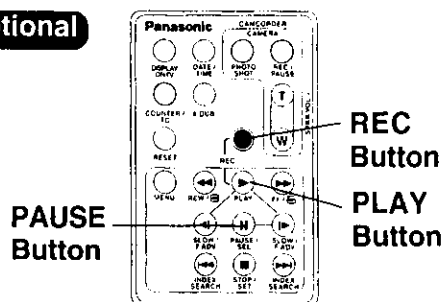

Before you begin...

- Connect both Palmcorders to their power sources.
- Connect the two Palmcorders using the DV interface cable (4-pin to 4-pin).
- Turn both Palmcorders ON.

1 Insert a **pre-recorded tape** into the source (playing) Palmcorder, and set **POWER** to **VCR**.

2 Insert a **blank tape with the record tab** in place into the target (recording) Palmcorder and set **POWER** to **VCR**.

3 Press **PLAY** on the source Palmcorder. When the tape reaches the point you want to start dubbing, press **PAUSE**.

4 Hold down **REC** and press **PLAY** the target (recording) Palmcorder or remote control (optional, page 58). Press **PAUSE** to pause the tape at the starting point of the dub.

5 Simultaneously, press **PAUSE Buttons** on both units to begin the dubbing.

6 Press **STOP** on recording unit, and then press **STOP** on playing unit to end dubbing.

Note

- When two Palmcorders are used for dubbing, it is recommended that the remote control VCR1 or VCR2 setting should be used to avoid mis-operation.
- When two Palmcorders are connected using the DV interface cable (not supplied), a Video Editing Controller cannot be used.
- Do not connect both an S-Video Cable or AV Cable and a DV Interface Cable.

CAUTION:

Unauthorized exchanging and/or copying of copyrighted recordings may be copyright infringement.

Special Features

PC Connection with DV Interface Cable (IEEE 1394)

A live image can be transferred directly to your PC (Personal Computer) via a DV Interface Cable (not supplied) using products and software from Digital Origin (formerly Radius) or Canopus.

Using these products allows you to capture live images onto your PC, edit the captured image, etc.

Note:

- For more detailed information, please their web site at:
<http://www.digitalorigin.com/DVP>
<http://www.justedit.com>
- For assistance on Digital Origin products, call 1-800-572-3487
For assistance on Canopus products, call 1-888-868-2533

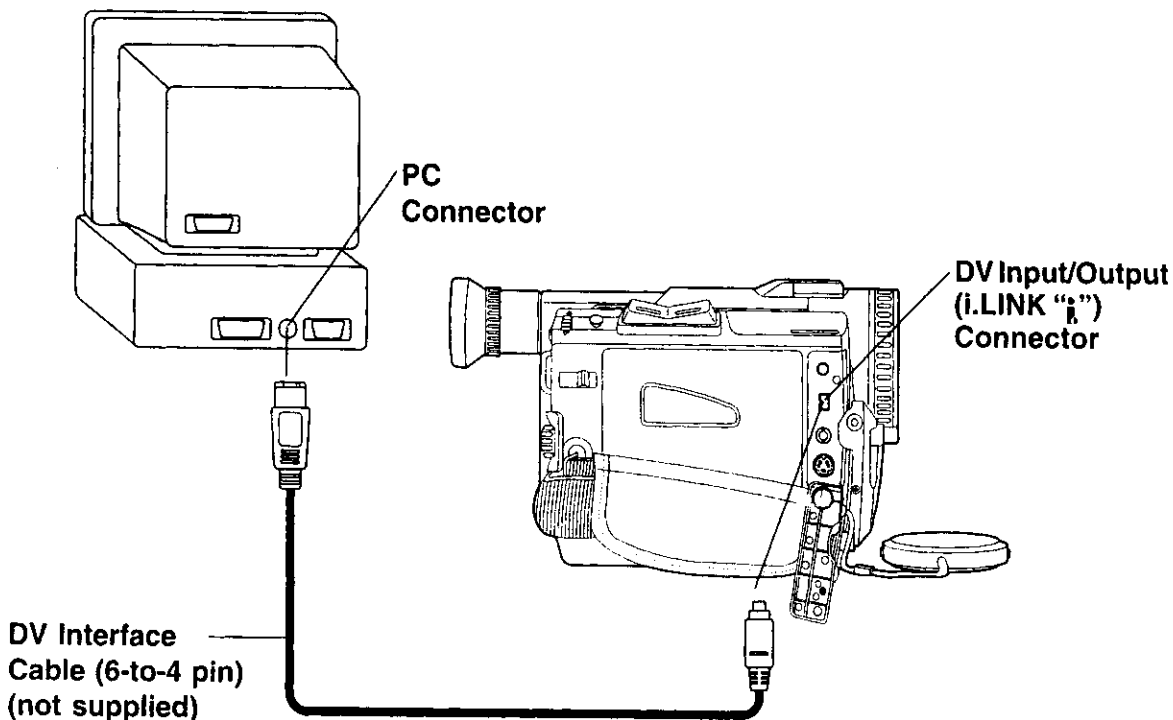

PC Connection

PHOTOVU Link Driver

An image stored in the DV Tape can be transferred to your PC (Personal Computer).

System Requirements for PHOTOVU LINK Driver

- IBM PC/AT or compatible.
- Intel® Pentium® Processor
- Microsoft Windows® 95 or Windows® 98
- RAM: 16 MB or more
- 2 MB minimum available hard disk space.
- 256 color monitor (full color recommended).
- 3.5 inch 1.44 MB floppy disk drive (for installation).
- RS-232C serial port (D-Sub 9-pin). An adaptor (D-Sub 9-pin male to a D-Sub female) is required for a D-Sub 25-pin.
- Mouse or other pointing device.

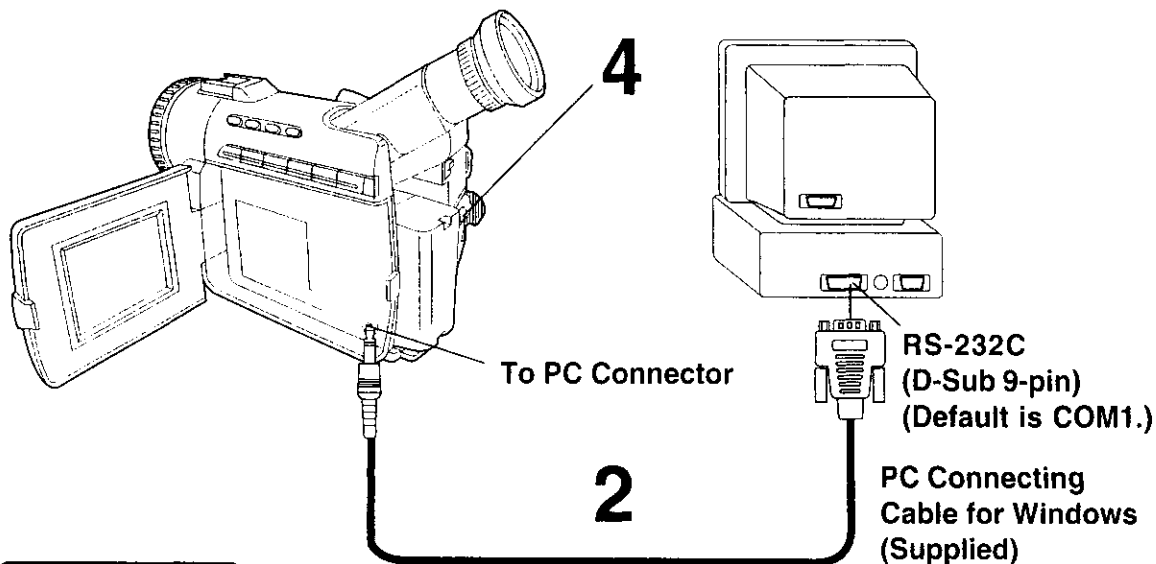

Connection

- 1** Turn off your PC.
- 2** Connect the Digital Video Camcorder to your PC (Windows) using the RS-232C PC connecting cable (supplied).
 - Before connecting the Palmcorder to the PC, make sure the PC power is off to insure that images are transferred properly.
- 3** Turn on your PC.
- 4** Set the Palmcorder POWER to VCR.

Note

- For extended periods of use, it is recommended to use the AC Adaptor as a power source.
- Refer to PC or Windows manual to identify which COM port to be used for connection.

Software Installation (Windows 95/98)

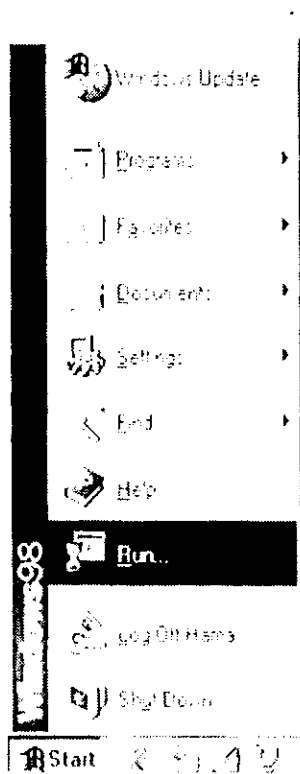

Before you begin...

- Your PC is in the power on mode.

- 1** Turn on PC (Personal computer) and start up Windows.
- 2** Insert **PHOTOVU LINK DRIVER Disk (Windows 95/98)** into a floppy disk drive.
- 3** Click on **Start**, then **“Run...”**

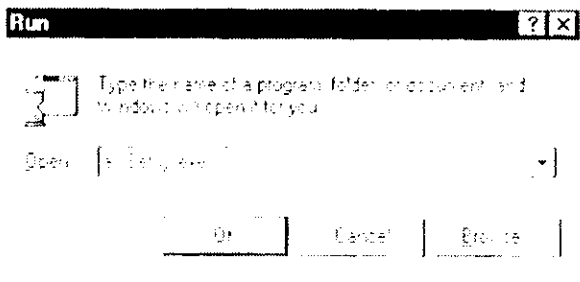

- 4** Type in **“a:\setup.exe”** and click **OK**.
 - If your 3.5 inch floppy disk drive is not “A”, use appropriate letter.
- 5** Follow instructions as they appear on PC screen until the installation is complete.
 - Setup window will disappear when the installation is complete.

PHOTOVU LINK

PHOTOVU LINK: You can transfer images from your Camcorder tape to a PC.

Running the Software (Windows 95/98)

Before you begin...

- Insert the Tape (page 7).
- Make Camcorder-PC connections (page 53).
- Turn your PC on.
- Set Camcorder POWER to VCR.

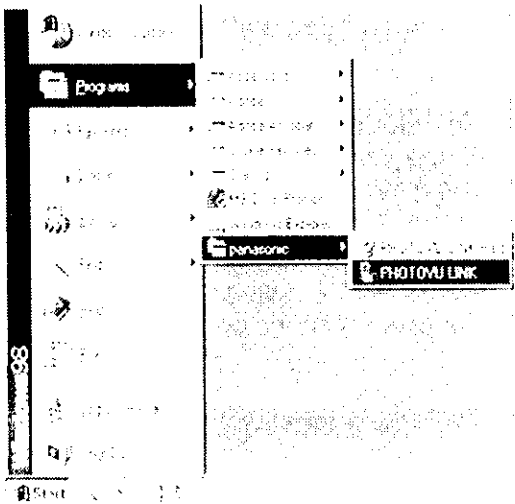

1 Click on Start, "Programs",
"panasonic", then "PHOTOVU LINK".

2 "PHOTOVU LINK" is opened.

Note

- COM Port and Baudrate are automatically selected.

Refer to Help for information about application operations and other Error messages.

PHOTOVU LINK

Using Tape Image Data

Pictures captured with Camcorder can be transferred to your PC.

Before you begin...

- Insert the Tape (page 7).
- Make Camcorder-PC connections (page 53).
- Turn your PC on.
- Set Camcorder POWER to VCR.

1 Repeat step 1 and 2 on page 55 to run the Software.

2 "Preview Window" screen appears.

3 Search and Select a video footage or a scene you want to transfer to your PC using VCR Operation Buttons on the "Preview window" screen. Then click on "**Transfer**" to transfer selected image from camcorder to "Preview Window" in PLAY or STILL mode.

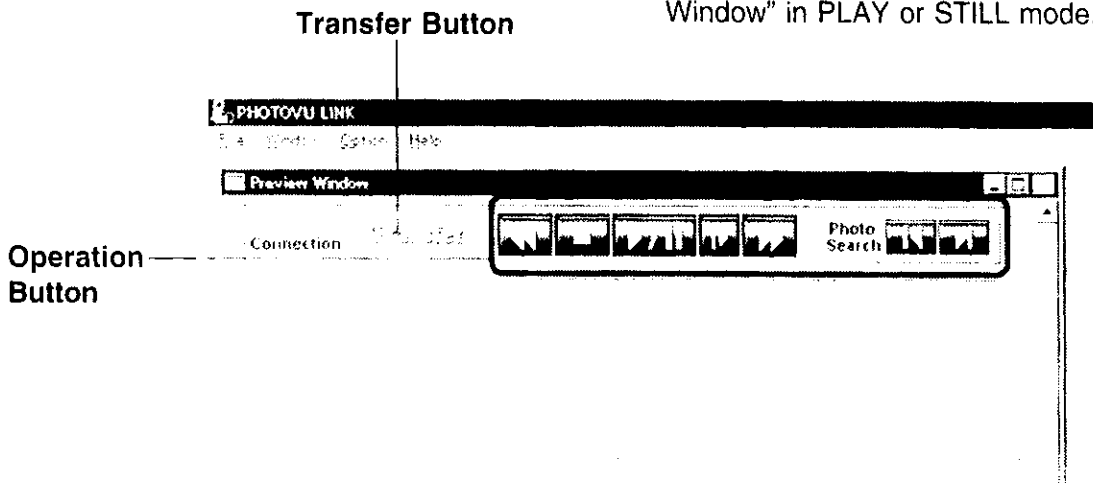

4 Save Transferred image to PC. Click on "File" then "Save As".

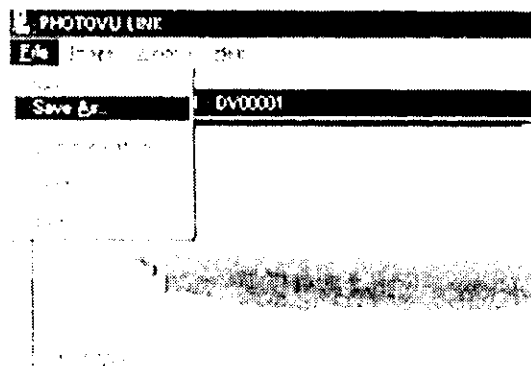

Note

- If, while transferring the image to your PC, the displayed picture appears abnormal, close PHOTOVU LINK and turn Camcorder POWER off, and reset PHOTOVU LINK, and turn Camcorder Power ON.
- Photo Search may fail to detect a recorded PhotoShot image if the image is 3 seconds or less.

Printer Connection

Using the Digital Photo Printer





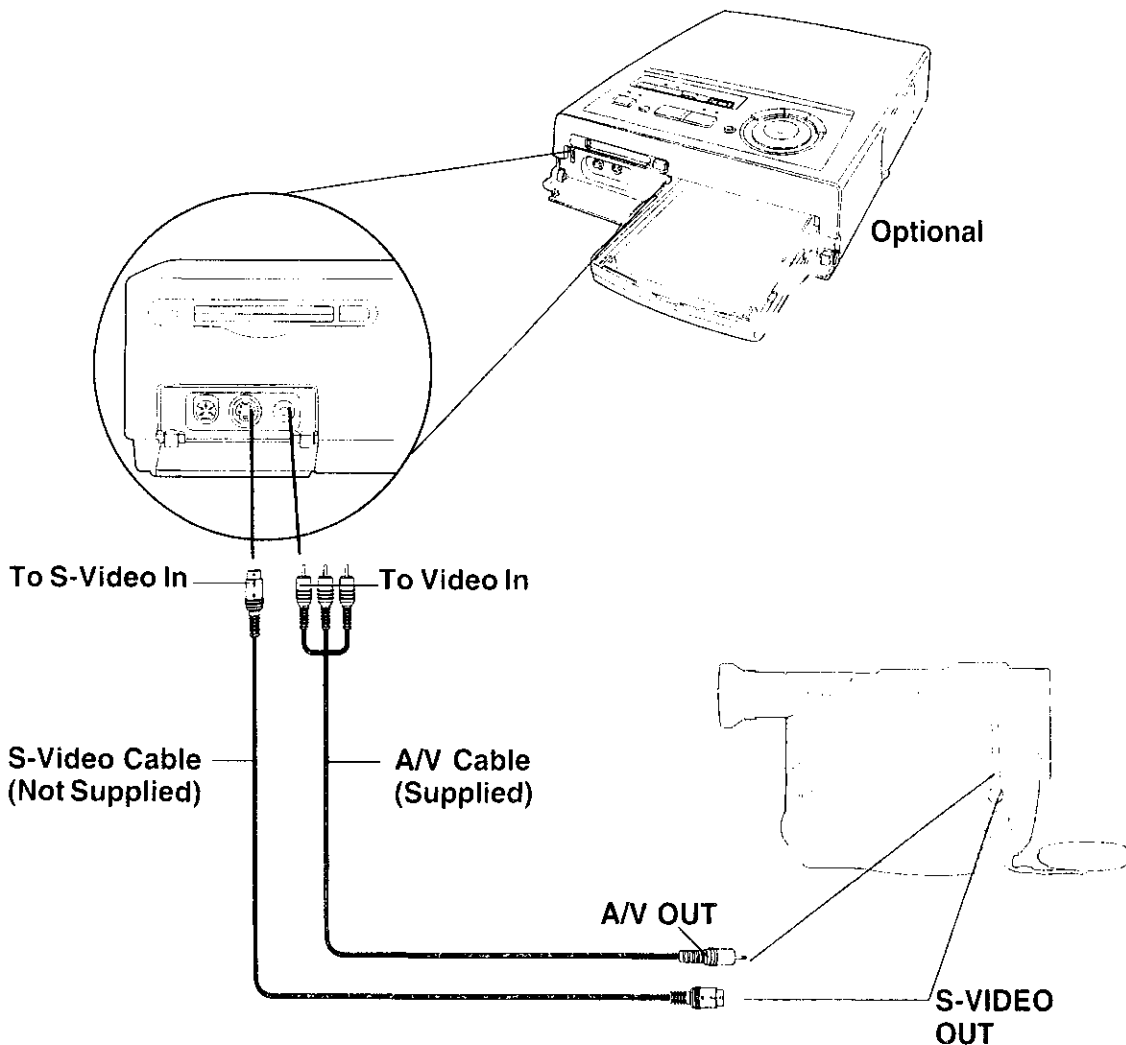

You can print out images by using a digital Photo Printer (Optional).

Before you begin...

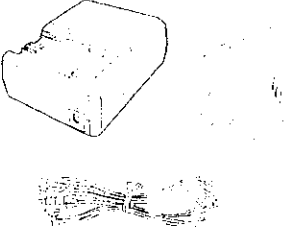
- Connect both Palmcorder and Digital Photo Printer to their power sources.
- Connect the Palmcorder and Digital Photo Printer using a A/V cable (supplied) or S-Video Cable (not supplied).
- Connect the Digital Photo Printer and your TV using a Video cable (not supplied) and turn the TV on.
- If different video sources are connected simultaneously to the S-VIDEO IN Socket and the VIDEO IN Socket, the video for S-VIDEO IN Socket takes precedence.
- To listen to sound from the Palmcorder, connect the audio output from the Palmcorder directly to the television AUDIO IN socket.
- Please refer to the printer's operating instructions for detail on printing.

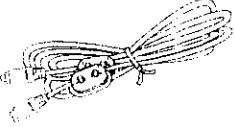
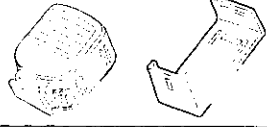

Palmcorder Accessory System

Accessory #	Figure	Description	Price
PV-DAC10		AC Adaptor with AC Cable and DC Cable	\$140.00
CGR-D120A/1B (Same as PV-DBP8/DBP8A)		800mAh / 1 h 15 min Battery Pack	\$60.00
CGR-D220A/1B (Same as PV-DBP9/DBP9A)		1600mAh / 2 h 50 min Battery Pack	\$100.00
CGR-D815A/1B		5300mAh / 9 h Battery Pack	\$200.00
PV-DDC9		DV Interface Cable (4-pin to 4-pin)	\$45.00
PV-DLT9		Color Enhancement Light	\$ 39.95
PV-DRC9		IR Remote Control	\$ 29.95
PV-PD2100		Digital Video Printer	\$599.95

Palmcorder Accessory Order Form

Please photocopy this form when placing an order.

1. Palmcorder Model # _____

2. Items Ordered

Accessory #	Description	Price Each	Quantity	Total Price
Subtotal				
Your State & Local Sales Tax				
Shipping & Handling				5.00
Total Enclosed				

3. Method of payment (check one)

- Check of Money Order enclosed (NO C.O.D.SHIPMENTS)
- VISA Credit Card # _____
- MasterCard Expiration Date _____
- Discover Customer Signature _____

Make Check or Money Order to: MATSUSHITA ACCESSORIES

(Please do not send cash)

4. Shipping information (UPS delivery requires complete street address)

Ship To:

Mr. _____

Mrs. _____

Ms. _____

First _____

Last _____

Phone #:

Day () _____

Street Address _____

Night () _____

City _____

State _____

Zip _____

TO OBTAIN ANY OF OUR OMNIMOVIE/PALMCORDER ACCESSORIES YOU CAN DO ANY OF THE FOLLOWING:

VISIT YOUR LOCAL PANASONIC DEALER

OR

CALL PANASONIC'S ACCESSORY ORDER LINE AT 1-800-332-5368

[6 AM-5 PM M-F, 6 AM-10:30 AM SAT, PACIFIC TIME]

OR

MAIL THIS ORDER TO: PANASONIC SERVICES COMPANY ACCESSORY ORDER OFFICE

20421 84th Avenue South Kent, WA. 98032

Notes On Operations

Cleaning EVF (Electronic Viewfinder)

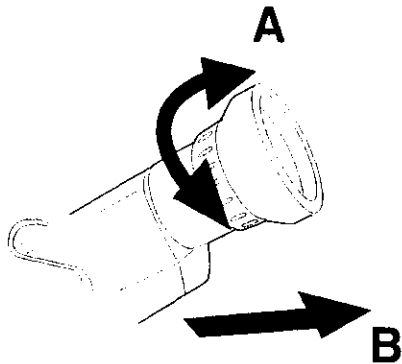

- 1** Turn the Eyepiece counterclockwise 1/8 of a turn.
- 2** Pull the Eyepiece free. Remove any lint or dust particles with a soft clean cloth being careful not to scratch the glass surfaces.
- 3 To re-install the Eyepiece** Line up the marks on the Eyepiece with the grooves inside the EVF shaft and attach. Turn it clockwise 1/8 of a turn to lock in place.

Notes On Operations

Rough Values of Brightness

Your Palmcorder has been designed for normal scene illumination of 150 footcandles (1500 lx). However, the Palmcorder may be used at F1:1.6, if illumination is more than 0.5 footcandles (5 lx).

The table below shows the color temperature for reference.

PALMCORDER SETTINGS	NATURAL LIGHT CONDITIONS	KELVIN COLOR TEMPERATURE	ARTIFICIAL LIGHT SOURCE	COLOR/TINT MIXTURE
	<ul style="list-style-type: none"> Fair weather, blue sky 	10,000	<ul style="list-style-type: none"> Color television 	Bluish
	<ul style="list-style-type: none"> Slightly cloudy sky 	8,000		
	<ul style="list-style-type: none"> Cloudy or rainy sky 	7,000		
		6,500	<ul style="list-style-type: none"> Fluorescent lamp (Daylight) Camera flash bulb 	
		6,000		
		5,500		
		5,000	<ul style="list-style-type: none"> Blue lamp for photography 	
		4,500	<ul style="list-style-type: none"> Fluorescent lamp (White) Normal flash bulb 	Whitish
		4,000	<ul style="list-style-type: none"> Fluorescent lamp (Off-white) 	
		3,500	<ul style="list-style-type: none"> Tungsten lamp for photography 	
	3,200			
	3,000	<ul style="list-style-type: none"> Halogen lamp Iodine lamp 		
	2,800			
	2,800	<ul style="list-style-type: none"> Tungsten lamp Acetylene lamp Kerosene lamp 	Yellowish	
	2,000	<ul style="list-style-type: none"> Candlelight 	Reddish	

Specifications

Power Source:	Digital Video Camera: 7.2 V DC (Battery) 7.8 V DC (AC Adaptor) AC Adaptor: 110/120/220/240 V AC, 50/60 Hz Battery: Lithium-Ion Type DC 7.2 V
Power Consumption:	Digital Video Camera: 7.2 V DC 6.5 W (Max. 9.5 W) AC Adaptor: 18 W 1 W (when not in use.)
Video Signal:	EIA Standard (525 lines, 60 fields) NTSC color signal
Video Recording System:	2 rotary heads, helical scanning system
Audio:	12 bit (32 kHz) 4 tracks 16 bit (48 kHz) 2 tracks
Pick-Up System and Device:	One integral color filter Charge Coupled Device (CCD)
Lens:	18:1 zoom lens, F1:1.6 with auto iris control Focal length: 3.9 mm - 70.2 mm Power zoom function Lens filter diameter: 49 mm
Viewfinder:	0.4 inch (10.2 mm) Electronic Viewfinder
LCD Monitor:	2.5 inch (63.5 mm) Liquid Crystal Display
Minimum Illumination Required:	5 lx (F1:1.6) 0.5 footcandles
Operating Temperature:	32 °F-104 °F (0°C-40°C)
Operating Humidity:	10 %-75 %
Weight:	Digital Video Camera: 1.54 lbs. 0.7 kg AC Adaptor: 0.4 lbs. 0.18 kg
Dimensions:	Digital Video Camera: 3-3/8 (W) x 4-1/4 (H) x 7-3/8 (D) inch 85 (W) x 107.5 (H) x 188 (D) mm AC Adaptor: 4 (W) x 1-5/8 (H) x 3-1/8 (D) inch 103 (W) x 40 (H) x 79 (D) mm

Weight and dimensions shown are approximate.
Designs and specifications are subject to change without notice.

Before Requesting Service

Cleaning Care for Video Heads

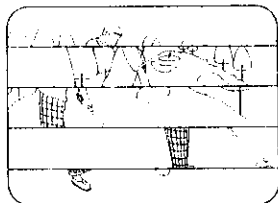

Clogged Video

Head

(a) Video Head Cleaning: Normally, your Palmcorder will not require head cleaning. However, it is possible that the heads may become clogged due to dust in the air, damaged tape, long term use, etc. If "NEED HEAD CLEANING" appears for 5 seconds in the EVF or LCD monitor, the heads may require cleaning.

(b) Cleaning the Heads: It is recommended that head cleaning be performed by a qualified service technician. Please contact your nearest Panasonic Service Center. An alternate solution is to obtain a head cleaning cassette. Please use Panasonic cleaning cassette (AY-DVMCL). Be sure to follow the cleaning instructions carefully. Excessive use of the cleaning cassette could shorten head life.

Use this cassette only when a head clogging symptom occurs.

Refer servicing to qualified service personnel.

Caution for Tape Operations

- When you go from function to function (PLAY, FF, REW etc.), please note that the unit will not accept a new function operation until the previous operation is complete.
- The POWER Button, and all function buttons, (PLAY, FF, REW, etc.) are only operational after the tape has been completely loaded.

Lens Hood Area Operation Caution

- With a Wide or Telephoto Conversion Lens (optional) attached, the four corners of the screen may darken when zoom is set to maximum wide angle.
- Attaching the lens hood, a Wide or Telephoto conversion lens (optional), etc. after a filter (optional) has been attached, the four corners of the screen may darken when zoom is set to maximum wide angle.
- With two filters (optional) attached, the four corners of the screen may darken when zoom is set to maximum wide angle.

Before Requesting Service

If you have a problem with your Palmcorder, it may be something you can correct yourself. Check the list below for symptoms and corrections.

Symptom	Correction
No picture in the EVF or LCD Monitor ...	<ul style="list-style-type: none"> • Make sure the Power Source is connected. (pp. 10, 11) • Make sure the POWER switch is set to ON. (pp. 28, 33) • Check the Dew Indicator. (p. 27) • Make sure the battery is fully charged. (p. 9) • Make sure all necessary cables are connected correctly and firmly. (p. 11)
Video cassette can't be inserted ...	<ul style="list-style-type: none"> • Make sure the Lens Cap is removed. (p. 28) • Make sure the Power Source is connected. (pp. 10, 11)
Video cassette can't be removed ...	<ul style="list-style-type: none"> • Insert the cassette with the window side facing up. (p. 7)
No operation starts when operation buttons are pressed ...	<ul style="list-style-type: none"> • Make sure the Power Source is connected. (pp. 10, 11)
Recording cannot be done ...	<ul style="list-style-type: none"> • Check the Dew Indicator. (p. 27) • Make sure the record tab is closed. (p. 13) • Check the Battery Indicator. (p. 25)
Auto Focus does not operate ...	<ul style="list-style-type: none"> • Make sure the FOCUS is set to AUTO. (p. 45) • Make sure the unit is ON with CAMERA mode. (p. 28)
Sound from microphone can't be monitored ...	<ul style="list-style-type: none"> • Make sure the unit is set to REC or Record/Pause mode.
Sound can't be heard ...	<ul style="list-style-type: none"> • Make sure the Audio on the VCR MENU is set to ST1. (pp. 22, 49)

Request for Service Notice

Please photocopy this form when making a request for service notice.

Request for Service Notice:

In the unlikely event this product needs service.

- Please include your **proof of purchase**.
(Failure to do so will delay your repair.)
- To further speed your repair please provide an explanation of what is wrong with the unit and any symptom it is exhibiting.

Mail this completed form and your Proof of Purchase along with your unit to:
Panasonic Services Company
1705 N. Randall Road
Elgin, IL. 60123-7847
Attn: Camcorder Repair

Please write the displayed Self Diagnostic number here.
(page 63)

Index of Controls

Front View

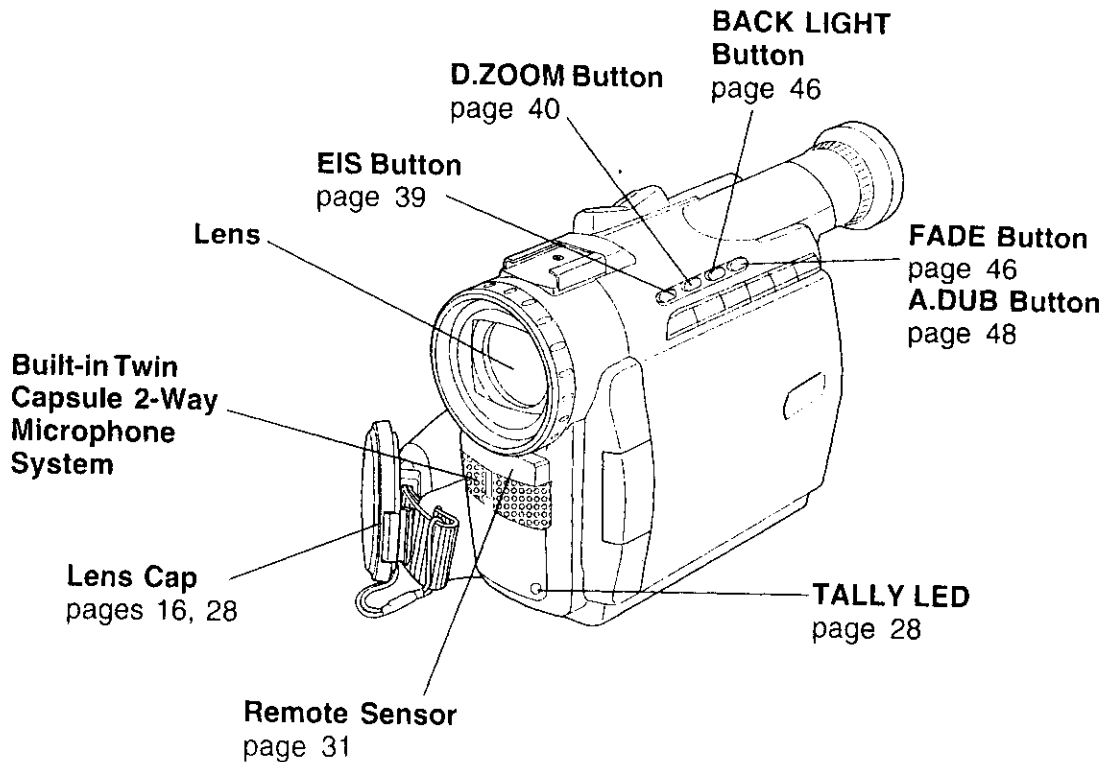

Front View

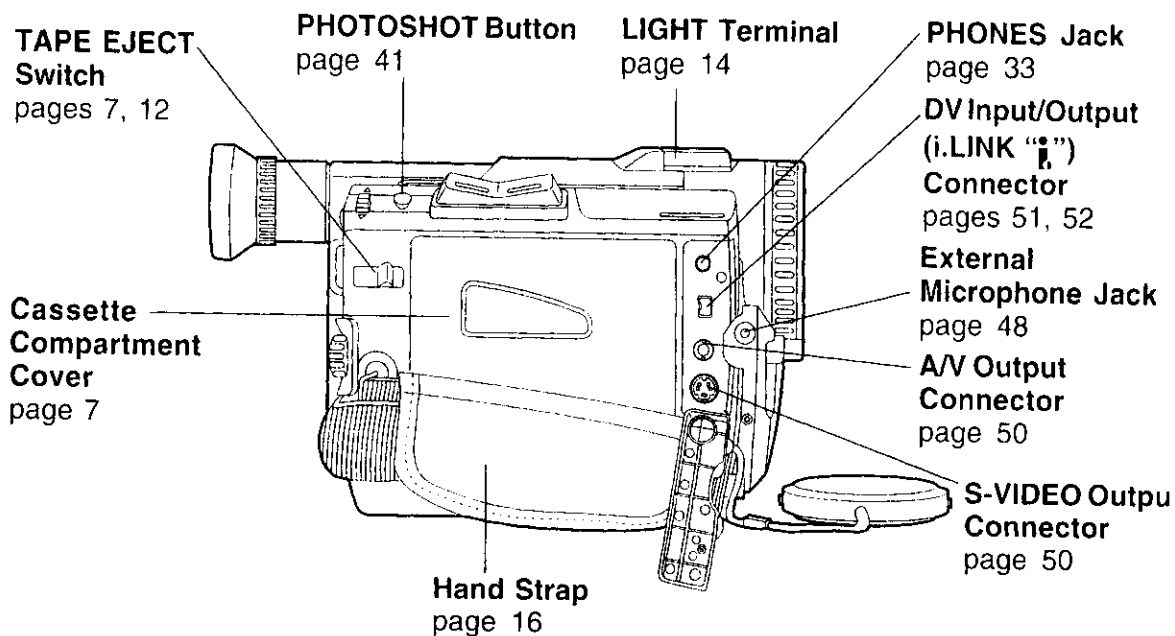

Index of Controls

Rear View

Electronic Viewfinder (EVF)
pages 7, 8, 24, 25, 26, 27

JOG KEY
pages 17, 18
VOLUME KEY
page 33

POWER ZOOM Button
pages 40, 45

Menu Button
pages 17, 18

Battery Release Button
pages 10, 11

Shoulder Strap Attachment Ring
page 15

POWER Lamp
page 28

POWER Switch
pages 7, 8

REC/PAUSE Button
pages 8, 28

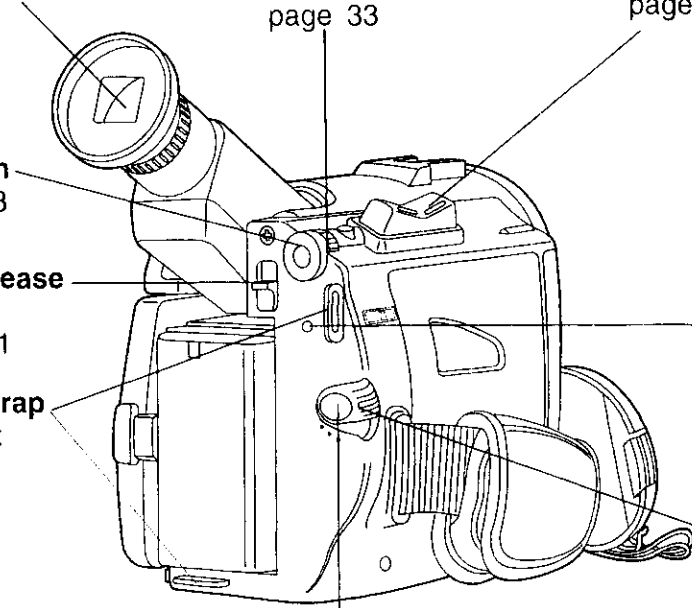

Rear View

LCD (Liquid Crystal Display) Monitor
pages 8, 24, 25, 26, 27

DC IN Terminal
page 11

LCD-OPEN Button
See pages 8, 33

Built-in Speaker
page 33

TO PC Connector
page 53

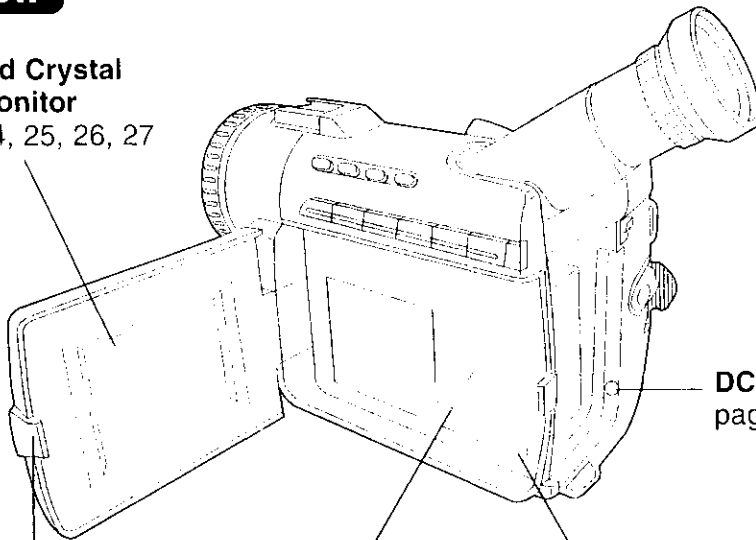

Index of Controls

Side View

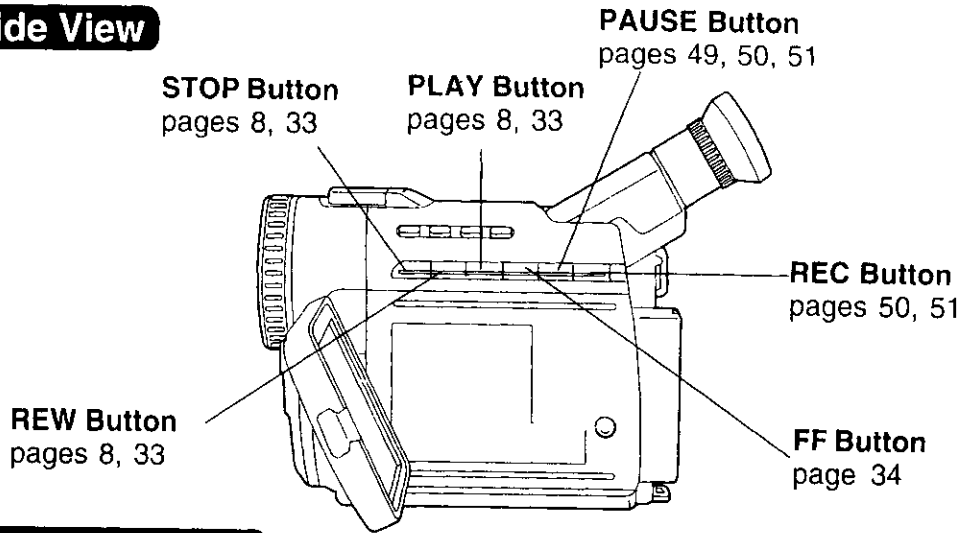

Underside View

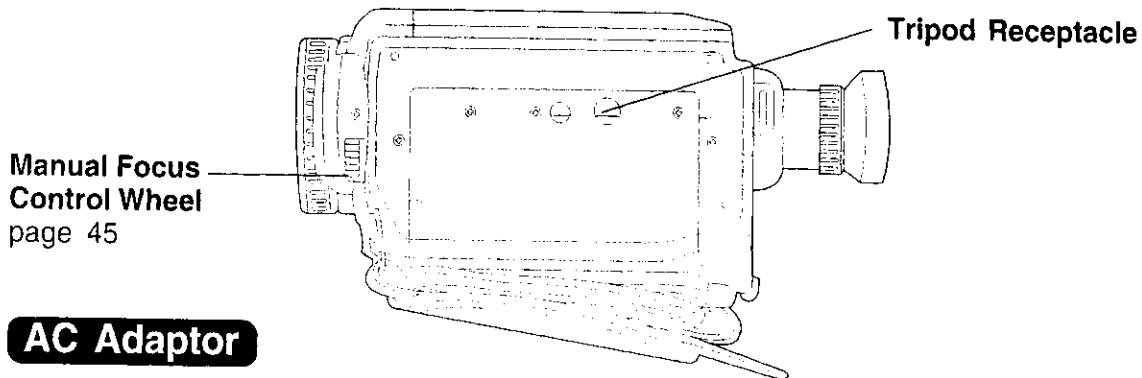

AC Adaptor

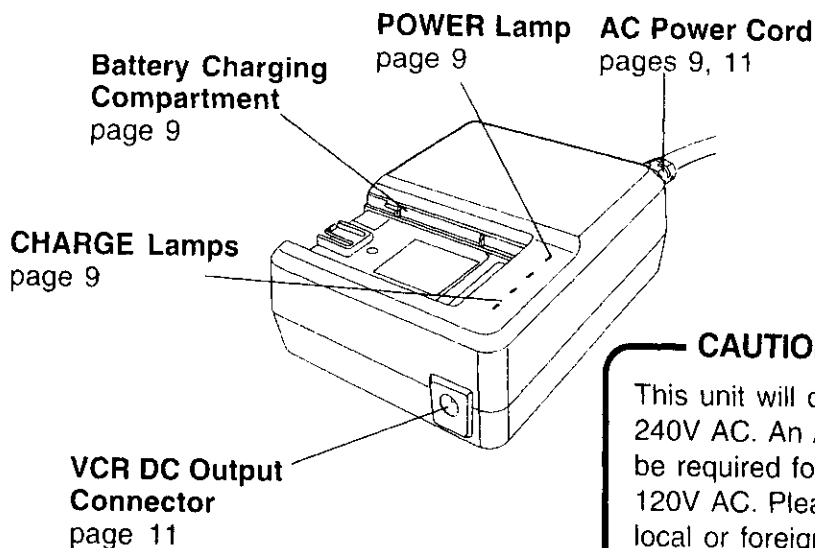

CAUTION:

This unit will operate on 110/120/220/240V AC. An AC plug adaptor may be required for voltages other than 120V AC. Please contact either a local or foreign electrical parts distributor for assistance in selecting an alternate AC plug. We recommend using the accessory power plug adaptor (VJSS0070) in an area which has special AC outlets.

Index of Controls

Remote Control (Optional)

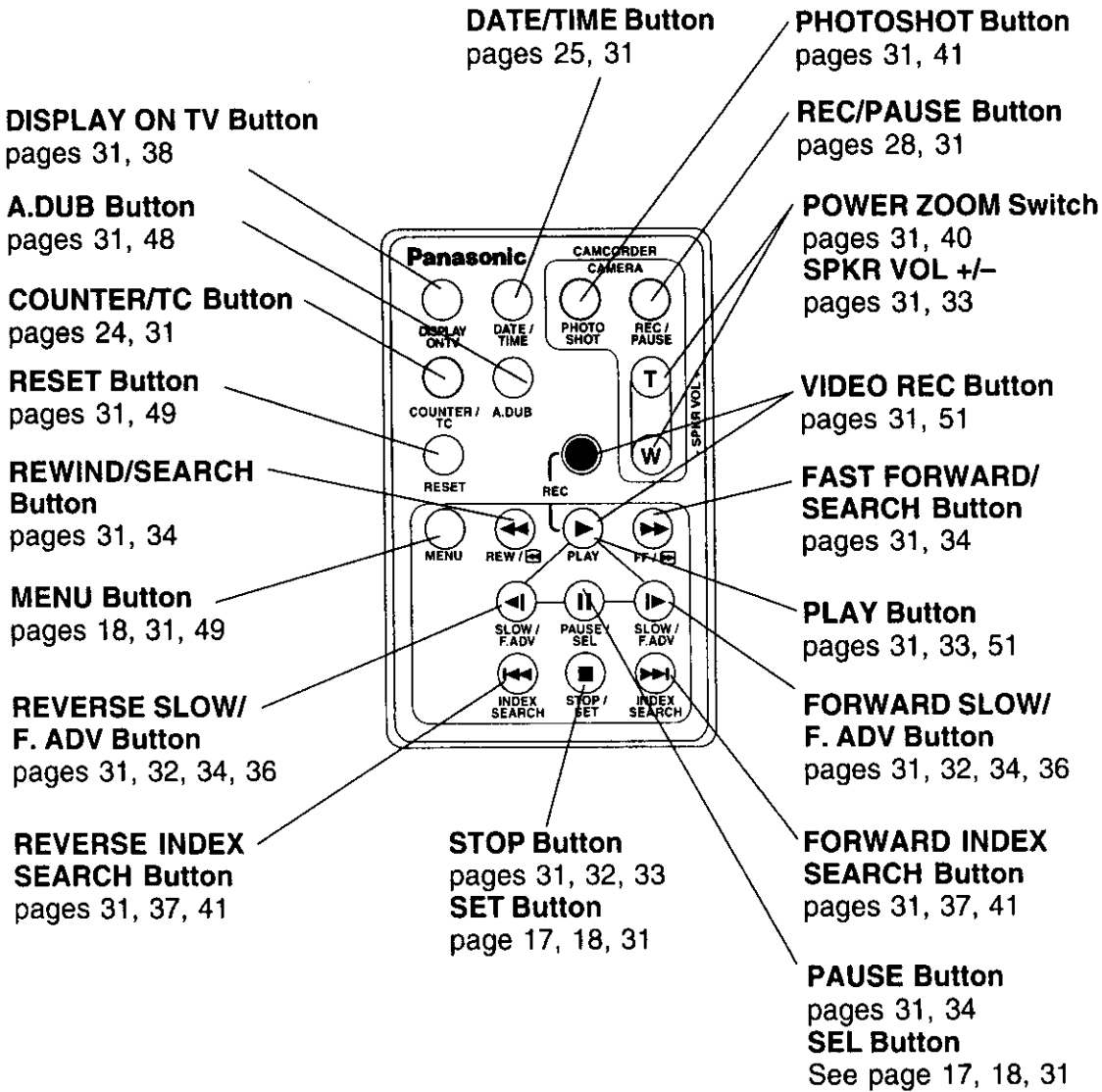

Warranty

Panasonic Consumer Electronics Company, Division of Matsushita Electric Corporation of America

One Panasonic Way Secaucus, New Jersey 07094

Panasonic Sales Company, Division of Matsushita Electric of Puerto Rico, Inc.

Ave. 65 de Infanteria. Km. 9.5 San Gabriel Industrial Park, Carolina, Puerto Rico 00985

PANASONIC/QUASAR Video Products Limited Warranty

Panasonic Consumer Electronics Company or Panasonic Sales Company (collectively referred to as "the Warrantor") will repair this product with new or refurbished parts, free of charge, in the USA or Puerto Rico, in the event of a defect in materials or workmanship as follows (all time periods commence from the date of the original purchase):

PRODUCT	PARTS	LABOR
CAMCORDER	ONE (1) YEAR, EXCEPT CCD IMAGE SENSOR	NINETY (90) DAYS
	CCD IMAGE SENSOR - SIX (6) MONTHS	NINETY (90) DAYS
VCR	ONE (1) YEAR	NINETY (90) DAYS
A/V MIXER	ONE (1) YEAR	NINETY (90) DAYS
MONITOR-VCR	ONE (1) YEAR, EXCEPT CRT	NINETY (90) DAYS
	CRT - TWO (2) YEARS	CRT- NINETY (90) DAYS CUSTOMER PAYS ALL LABOR CHARGES AFTER 90 DAYS

Monitor-VCR In-home or carry-in Service: 22" (diagonal) CRT / LCD and Larger
Monitor-VCR Carry-in Service: 21" (diagonal) CRT / LCD and smaller

Batteries (if included) - New rechargeable batteries in exchange for defective rechargeable batteries for ten (10) days. Non-rechargeable batteries are not warranted.

Tape (if included) - New video cassette tape in exchange for a defective video cassette tape for five (5) days.

In-home, carry-in or mail-in service, as applicable, in the USA can be obtained during the warranty period by contacting a Panasonic Services Company (PASC) Factory Service Center listed in the Service Directory. Or call toll free 1-800-211-PANA(7262), to locate an authorized PASC Service Center. Carry-in or mail-in service in Puerto Rico can be obtained during the warranty period by calling the Panasonic Sales Company telephone number listed in the Service Center Directory.

This warranty is extended only to the original purchaser. A purchase receipt or other proof of the date of the original purchase is required before warranty service is rendered.

This warranty only covers failures due to defects in materials and workmanship which occur during normal use and does not cover normal maintenance, including, but not limited to, video and audio head cleaning. The warranty does not cover damage which occurs in shipment, or failures which are caused by products not supplied by the warrantor, or failures which result from accident, misuse, abuse, neglect, mishandling, misapplication, alteration, modification, faulty installation, set-up adjustments, improper antenna, inadequate signal pickup, maladjustment of consumer controls, improper operation, power line surge, improper voltage supply, lightning damage, commercial use such as hotel, office, restaurant, or other business or rental use of the product, or service by anyone other than a PASC Factory Service Center or a PASC authorized Service Center, or damage that is attributable to acts of God.

LIMITS AND EXCLUSIONS

There are no express warranties except as listed above. THE WARRANTOR SHALL NOT BE LIABLE FOR INCIDENTAL OR CONSEQUENTIAL DAMAGES (INCLUDING, WITHOUT LIMITATION, DAMAGE TO TAPES) RESULTING FROM THE USE OF THIS PRODUCTS, OR ARISING OUT OF ANY BREACH OF THE WARRANTY. ALL EXPRESS AND IMPLIED WARRANTIES, INCLUDING THE WARRANTIES OF MERCHANTABILITY AND FITNESS FOR PARTICULAR PURPOSE, ARE LIMITED TO THE APPLICABLE WARRANTY PERIOD SET FORTH ABOVE. Some states do not allow the exclusion or limitation of incidental or consequential damages, or limitations on how long an implied warranty lasts, so the above exclusions or limitations may not apply to you.

This warranty gives you specific legal rights and you may also have other rights which vary from state to state.

If a problem with this product develops during or after the warranty period, you may contact your dealer or Service Center. If the problem is not handled to your satisfaction, then write to the Customer Satisfaction Center at the Panasonic Consumer Electronics Company address above. SERVICE CALLS WHICH DO NOT INVOLVE DEFECTIVE MATERIALS OR WORKMANSHIP AS DETERMINED BY THE WARRANTOR, IN ITS SOLE DISCRETION, ARE NOT COVERED. COSTS OF SUCH SERVICE CALLS ARE THE RESPONSIBILITY OF THE PURCHASER.

warvid 10/20/97

Warranty

For Product Information, operating Assistance, Literature Request, Dealer Locations, and all Customer Service inquiries please contact:
1-800-211-PANA(7262), Monday-Friday 9am-9pm Saturday-Sunday 9am-7am, EST.

Web Site: <http://www.panasonic.com>
You can purchase parts, accessories or locate your nearest service center by visiting our Web Site.

Accessory Purchases:

1-800-332-5368 (Customer Orders Only)
Panasonic Service Company 20421 84th Avenue South, Kent, WA 98032
(6 am to 5 pm Monday - Friday; 6 am to 10:30 am Saturday; PST)
(Visa, Master Card, Discover Card, American Express, Check)

Product Repairs

Centralized Factory Service Center

Panasonic Services Company
MAIL TO : 1705 N. Randall Road,
Elgin, IL 60123-7847
Attention: Digital Camera Repair

Please carefully pack and ship, prepaid and insured, to the Elgin centralized repair Factory Service Center. While there will be added handling delays, you may bring your unit to one of the following locations who will then forward the unit to Elgin for repair.
Customer's in Puerto Rico, please ship or carry in to location below ("Service in Puerto Rico").

Factory Service Center Locations

CALIFORNIA

550 Katella Avenue
Cypress, CA 90630
800 Dubuque Avenue
S. San Francisco,
CA 94080
20201 Sherman Way
Suite 102
Canoga Park, CA 91306
3878 Ruffin Road
Suite A
San Diego, CA 92123

COLORADO

1640 South Abilene
Street Suite D
Aurora, CO 80012

FLORIDA

3700 North 29th Avenue
Suite 102
Hollywood, FL 33020

GEORGIA

8655 Roswell Road
Suite 100
Atlanta, GA 30350

ILLINOIS

9060 Golf Road
Niles, IL 60714
1703 North Randall Road
Elgin, IL 60123
(Pick-up / Drop-off only)

MARYLAND

62 Mountain Road
Glen Burnie MD 21061

MASSACHUSETTS

60 Glacier Drive,
Suite G
Westwood, MA 02090

MICHIGAN

37048 Van Dyke Avenue
Sterling Heights, MI
48312

MINNESOTA

7850-12th Avenue South
Airport Business Center
Bloomington, MN 55425

OHIO

2236 Waycross Road
Civic Center Plaza
Forest Park, OH 45240

PENNSYLVANIA

2221 Cabot Blvd. West
Suite B
Langhorne, PA 19047
Chartiers Valley
Shopping Center
1025 Washington Pike
Bridgeville, PA 15017

TENNESSEE

3800 Ezel Road
Suite 806
Nashville, TN 37211

TEXAS

7482 Harwin Drive
Houston, TX 77036
13615 Welch Road
Suite 101
Farmers Branch,
TX 75244

WASHINGTON

20425-84th Avenue
South
Kent, WA 98032

HAWAII

99-859 Iwaiwa Street
Aiea, Hawaii 96701
Phone (808) 488-1996
Fax (808) 486-4369

Service in Puerto Rico

Matsushita Electric of Puerto Rico, Inc. Panasonic Sales Company/ Factory ServiceCenter:
Ave. 65 de Infantería. Km. 9.5 San Gabriel Industrial Park Carolina, Puerto Rico 00985
Phone (787) 750-4300 Fax (787) 768-2910

Index

A

AC Adaptor	2, 9, 11, 58, 68
Accessories (Optional)	58
Accessories (Supplied)	2
Audio/Video Cable	2, 38, 50
Audio/Video Fade In/Out	46
Auto Focus	45

B

Backlight	46
Battery Charging Confirmation Marker	9
Battery Pack	2, 7, 9, 10, 58
Battery Remaining Indication	24
Battery Warning	27
Before Requesting Service	63
Blank Search	31

C

Camera Recording	28, 29, 30, 31
Cleaning Care for Video Heads	63
Clock Battery	17, 27
Clock Set	17
Color Enhancement Light (Optional)	14
Copying from Digital Equipment	51
Copying your Tapes	50

D

Date and Time Indication	25
DC Power Cable	2, 11, 58
DEW Indication	27
Digital E.I.S.	39
Digital Functions	44
Digital PhotoShot	41
Digital Video Cassette Tape	13
Digital Zoom	40
Dubbing over Audio(Microphone)	48, 49
DV Interface Cable	51, 52, 58

E

Edit Search	30
Erase Protection Tab	13
EVF/LCD Monitor Indications	24, 25, 26, 27

F

Fade In/Out	46
-------------	----

H

Hand Strap	16
High Speed Shutter	47

J

Jog Search	36
------------	----

L

Lens Cap	2, 16, 28
----------	-----------

M

Macro Focus	45
Manual Focus	45
Memory Counter	24
MENU OSD	19, 20, 21, 22, 23

P

PC Connection	53
PC Connection Cable	2, 53
PLAY Indicator	25
Playback	33, 34, 35, 36, 37, 38
Power Supply	9, 10, 11
Program AE	43

R

REC Indicator	25
Recording Still Pictures	42
Remote Control	31, 32, 58, 69
Request for Service Notice	65