

SEARS Kenmore

CONTENTS

SAFETY

..... 1-5

USE AND CARE

Removal of Packaging Tape	5
Your Range and Its Features	6
Oven Vent	7
Cooktop Controls	7, 8
Clock and Timer	9, 11, 12, 15
Oven Cooking Tips	9, 10
Baking	11, 12
Roasting	12
Broiling	13
The Self-Clean Cycle	14, 15

CLEANING

Cleaning Tips	16
Removable Parts	17, 18

BEFORE CALLING FOR SERVICE

What to Do Before Calling for Service	19, 20
"Do It Yourself" Temperature Adjustments	20

WARRANTY

MODELS 64241, 93241,
93245, 93251



USE • CARE • SAFETY MANUAL



Recycled Paper

229C4020P002-3 SR10199

	WARNING
	<ul style="list-style-type: none"> • ALL RANGES CAN TIP • INJURY TO PERSONS COULD RESULT • INSTALL ANTI-TIP DEVICE PACKED WITH RANGE • SEE INSTALLATION INSTRUCTIONS

STABILITY DEVICE INSTALLATION INSTRUCTIONS FOR BRACKET KIT NO. 342473

TOOLS NEEDED: Phillips head screwdriver
1 3/8" open end or adjustable wrench

Bracket attaches to floor or wall to hold either right or left rear leg leveler. If fastening to floor, be sure that screws do not penetrate electrical wiring or plumbing. If this cannot be determined, use shorter screws that will not penetrate through flooring.

If the bracket came with your range, it is shipped in the prepack located inside the oven. Remove the bracket from the prepack and follow the instructions below.

1. Decide whether the bracket will be installed on the right or left side of range location.
2. If the bracket side of the range is adjacent to a cabinet, place the bracket against back wall and cabinet as shown in Figure 1.

If there is no adjacent cabinet, determine where the location of the range side (painted outside panel) will be. Place the bracket with its outside edge at this location and against back wall. See Figure 1.

3. Determine whether you will anchor the bracket to the floor or wall. Fasten the bracket securely with the screws provided. Screws are self-drilling in wood, plywood, particle and chip board, and most metal framing. If attaching to masonry, you can buy suitable screws and anchors at hardware stores. Use a masonry drill to drill the required holes.
4. Using the wrench, back out the four leg levelers at least two turns. See your installation guide for more leveling information before positioning range.
5. Slide the range into place. Be sure rear leg leveler fully engages slot in bracket. If range cannot be moved back far enough for rear leg leveler to enter bracket, move bracket forward as required and attach to floor in new location.

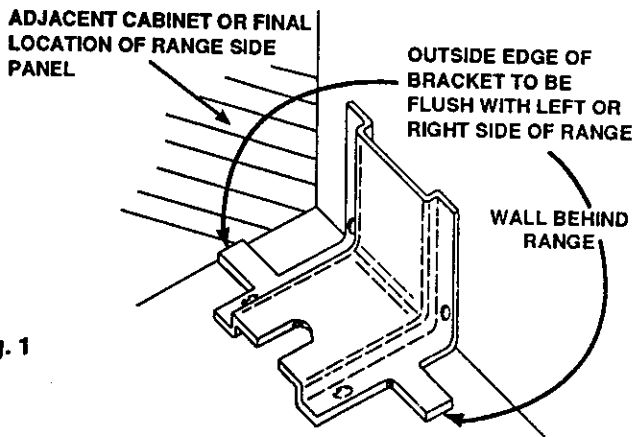

Fig. 1

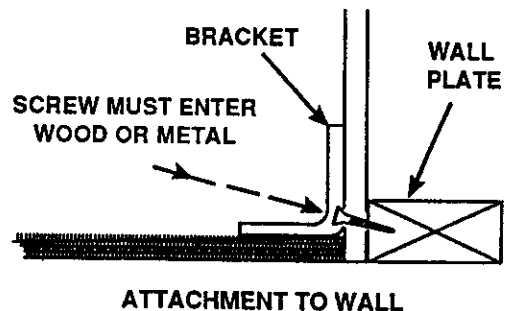

Fig. 2

IMPORTANT IMPORTANT IMPORTANT IMPORTANT IMPORTANT IMPORTANT IMPORTANT IMPORTANT IMPORTANT

IMPORTANT INSTRUCTIONS FOR YOUR SAFETY

SAVE THESE INSTRUCTIONS

Read all instructions before using this appliance. When using electrical appliances, basic safety precautions should be followed, including the following:



Teach children not to play with range knobs or any other part of the range. Never leave children alone or unattended where a range is in use.

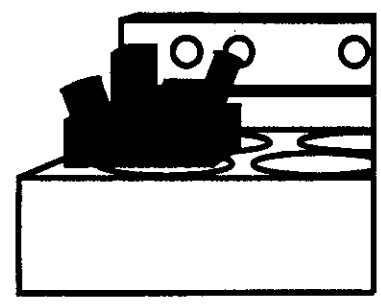

CAUTION:

Items of interest to children should not be stored in cabinets above the range or on the backsplash of the range. Children climbing on the range to reach items could be seriously injured.



Never let anyone climb, sit or stand on the open door or any other part of the range. Their weight may make the range tip over.

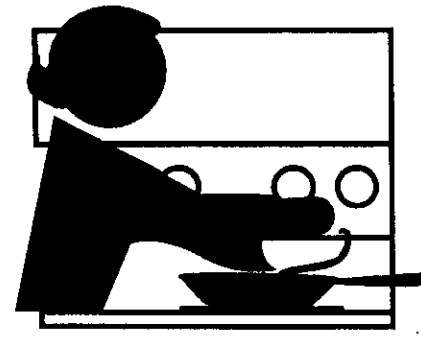

Never leave the oven door open when you are not watching the range.



IMPORTANT
IMPORTANT
IMPORTANT
IMPORTANT
IMPORTANT
IMPORTANT
IMPORTANT
IMPORTANT
IMPORTANT
IMPORTANT

To insure safety for yourself and your home, please read your Owner's Manual carefully. Keep it handy for quick easy reference. Pay close attention to the safety sections of your manual. You can recognize the safety sections by looking for the  symbol or the word "Safety".

Always keep the range area clear and free from things that will burn.

CAUTION:

Never store things in an oven or near cooktop elements/burners. These things may catch fire and plastic items could melt.

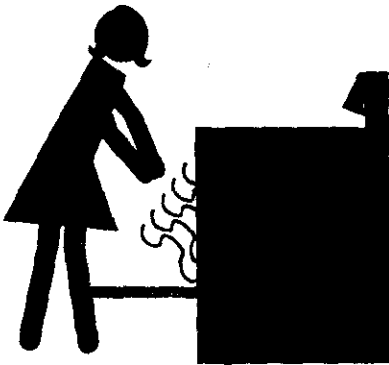

Never use your range for warming or heating a room. You could be burned or seriously injured. Such misuse could also cause damage to the range.

Never wear loose clothing when using your range. Such clothing could catch fire.



Never use a towel or other bulky cloth as a potholder. Such cloths could catch fire on a hot element/burner.

Never let pot handles stick out over the front of the range. Turn handles in so that they cannot be bumped into. Keep the handles away from other hot surface elements/burners.

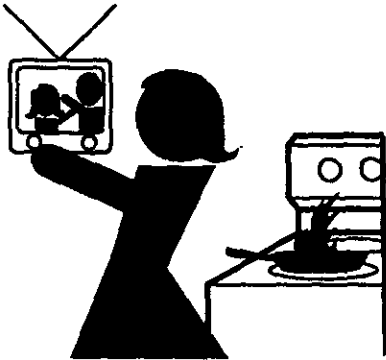

Never leave cooktop elements/burners unwatched at high heat settings. Boilovers cause smoking and greasy splillovers could catch fire.

IMPORTANT SAFETY INSTRUCTIONS

BASIC SAFETY PRECAUTIONS

Keep this book for later use.

Be sure your range is installed and grounded properly by a qualified technician.

Always use dry potholders when removing pans from the oven or cooktop. Moist or damp potholders can cause steam burns.

Always follow cleaning instructions in this book.

Always keep the range and oven clean. Food and grease are easy to ignite. Clean the range, oven and vents regularly.

Clean Only Parts Listed in Manual.

CAUTION: Do not store items of interest to children in cabinets above a range or on the backguard of a range. Children climbing on a range to reach items could be seriously injured.

Always keep combustible wall coverings, curtains, or drapes a safe distance away from your range and oven.

Always keep dish towels, dish cloths, potholders and other linens a safe distance away from your range. Never store such items on your range.

Always keep the appliance area clear and free from things that will burn (gasoline and other flammable vapors and liquids).

Never try to repair or replace any part of the range unless instructions are given in this book. All other work should be done by a skilled technician.

Never heat unopened food containers. Pressure buildup may make container burst and cause injury.

Never leave jars or cans of fat or drippings on or near the range. Never let grease build up on your range. You can keep grease fires from starting if you clean up grease and spills after each range use.

Never try to move a pan of hot fat, especially a deep fat fryer. Wait until the fat has cooled.

Never touch surface units, heating elements, or interior surfaces of the oven. They may be hot even though they appear dark in color.

Always keep wooden utensils, plastic utensils or canned food a safe distance away from your range.



Some cleaners produce noxious fumes and wet cloths or sponges could cause steam burns if used on a hot surface.

COOKTOP SAFETY

Always use care when touching the cooktop. Heating elements could be hot enough to burn you even if they are dark in color.

Only some kinds of glass or ceramic pans can be used for cooktop cooking. Be sure that the pan you use will not break when heated on the cooktop elements.

Never block free airflow through the oven vent.



Choose pots and pans with flat bottoms, large enough to cover the entire cooktop element. This will cut down the risk of setting potholders or clothing on fire with an uncovered element and waste less energy.

OVEN SAFETY

Place oven racks in desired position while oven is cool. If rack must be moved while oven is hot, do not let potholder contact hot heating element in oven.

After broiling, always take the broiler pan out of the range and clean it. Leftover grease in the broiler pan can catch on fire next time you use the pan.

Always use care when opening oven door. Let hot air and steam out before moving food.

Never use aluminum foil to line drip bowls or oven bottoms. Improper use of foil could start a fire.

SELF-CLEAN SAFETY

If the self-cleaning mode malfunctions, turn off and disconnect the power supply. Have serviced by a qualified technician.

Always remove broiler pan and other utensils from the oven before a self-clean cycle.

Never rub, move, or damage the door gasket on self-cleaning ranges. The gasket is essential for a good seal.

Never try to clean utensils, cookware or removable parts of your range during a self-clean cycle.

Do Not Use Oven Cleaners — No commercial oven cleaner or oven liner protective coating of any kind should be used in or around any part of the oven.

SAFETY INSTRUCTIONS (continued)

READ AND UNDERSTAND THIS INFORMATION NOW!

Should you ever need it, you will not have time for reading.

Be sure everyone in your home knows what to do in case of fire.

Never use water on a grease fire - It will only spread the flames.

COOKTOP GREASE FIRE



Never pick up a flaming pan...Instead:

1. Turn off the element.
2. Smother the fire with a tightly fitting pan lid, baking soda or an extinguisher.

OVEN FIRE —

DO NOT TRY TO MOVE THE PAN!



1. Close oven door and turn controls off.
2. If fire continues, throw baking soda on the fire, or use a dry chemical, foam, or halon type extinguisher.

IMPORTANT SAFETY NOTICE

The California Safe Drinking Water and Toxic Enforcement Act requires the governor of California to publish a list of substances known to the state to cause birth defects or other reproductive harm and requires businesses to warn customers of potential exposure to such substances.

The fiberglass insulation in self-clean ovens gives off a very small amount of carbon monoxide during the cleaning cycle. Exposure can be minimized by venting with an open window or using a ventilation fan or hood.

REMOVAL OF PACKAGING TAPE:

To remove adhesive left from packing tape and ensure you do not damage the finish of your new appliance, use an application of household liquid dish washing detergent, mineral oil, or cooking oil. Apply with soft cloth and allow to soak. Wipe with soft cloth. **DO NOT** use plastic pad or equivalent. Wipe dry and then apply an appliance polish to thoroughly clean and protect the surface. This procedure is also safe for the face of microwave doors and other plastic parts.

NOTE: The plastic tape must be removed from chrome trim on range parts. It **CANNOT** be removed if baked on.

WHERE CAN YOU LOOK FOR PACKAGING TAPE?

Elements
Drip pans
Control panel: top, sides, and bottom
Under maintop
Door trim: top, sides, and bottom
Bake element
Door handles

YOUR RANGE

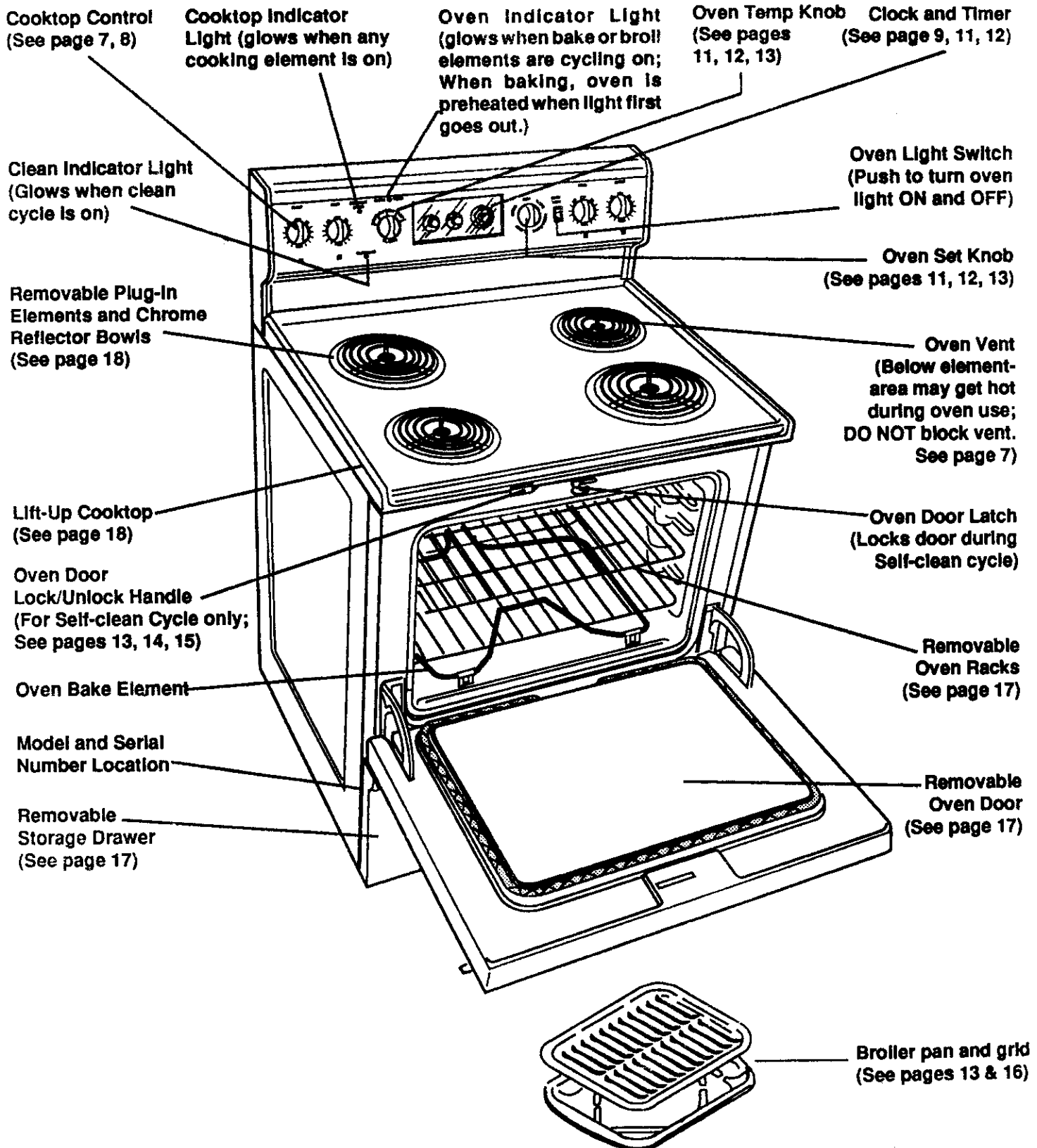

TO START THINGS COOKING

COOKTOP COOKING

Before you use the cooktop for the first time, take a few moments to familiarize yourself with the elements and the knob used to turn on each element.

COOKTOP ELEMENTS

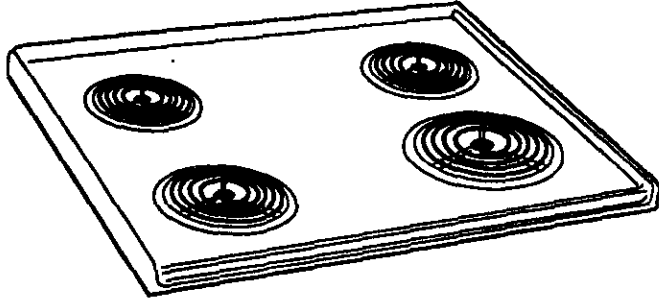

The sign near each cooktop control knob shows which element is turned on by that knob.

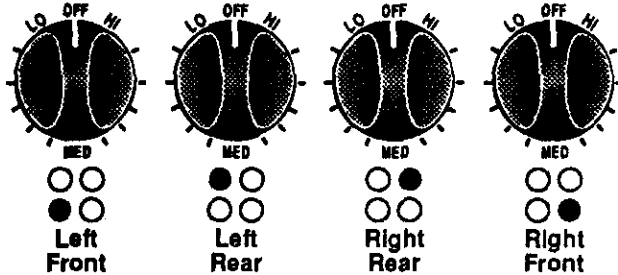

To operate cooktop controls:

1. Push to turn.

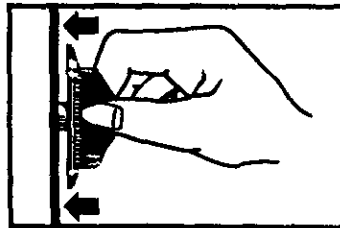

2. Set on or between marks for desired heat.

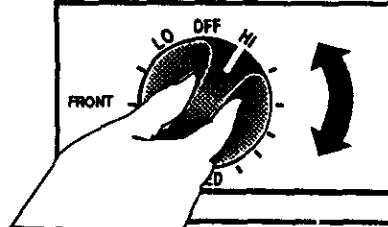

The indicator light will glow when any heating element is activated.

COOKTOP GUIDE TO BASIC SETTINGS

"HI"

Used for quick starts, such as bringing water to a boil.



"MED-HI"

Used for frying and rapid boiling.



"MED"

Used for slow boil and sautéing.

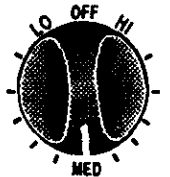

"MED-LO"

Used for cooking foods in small amounts of water.



"LO"

Used for steaming foods or keeping foods at serving temperature.

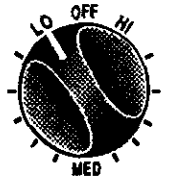

Never line the bowls below cooktop elements with aluminum foil. Foil can block normal heat flow, and damage the range. This is especially true if foil blocks the oven vent tube under the right rear cooktop element.

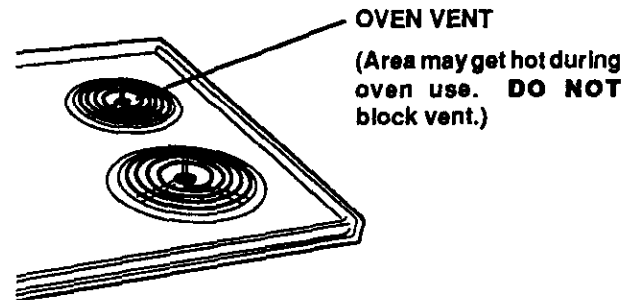

To Start Things Cooking (cont.)

For best cooking results and energy efficient operation, you should use pans that are flat on the bottom. Match the size of the pan to the size of the surface unit. The pan should not extend over the edge of the drip bowl more than 1".



Note: A slight odor is normal when a new cooktop is used for the first time. It is caused by the heating of new parts and insulating materials and will disappear in a short time.

WOK COOKING

We recommend that you use only a flat-bottom wok. They are available at your local retail store.

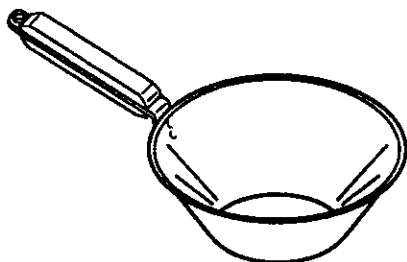

HOME CANNING TIPS

In surface cooking of foods other than canning, the use of large-diameter pots (extending more than 1" beyond edge of drip pan) is not recommended. However, when canning with water-bath or pressure canner, large-diameter pots may be used. This is because boiling water temperatures (even under pressure) are not harmful to cooktop surfaces surrounding heating unit.

HOWEVER, DO NOT USE LARGE DIAMETER CANNERS OR OTHER LARGE DIAMETER POTS FOR FRYING OR BOILING FOODS OTHER THAN WATER.

Most syrup or sauce mixtures — and all types of frying — cook at temperatures much higher than boiling water. Such temperatures could eventually harm cooktop surfaces surrounding heating units.

OBSERVE FOLLOWING POINTS IN CANNING

1. Bring water to boil on HIGH heat, then after boiling has begun, adjust heat to lowest setting to maintain boil (saves energy and best uses surface unit).
2. Be sure canner fits over center of surface unit. If your range does not allow canner to be centered on surface unit, use smaller-diameter pots for good canning results.
3. Flat-bottomed canners give best canning results. Be sure bottom of canner is flat or slight indentation fits snugly over surface unit. Canners with flanged or rippled bottoms (often found in enamelware) are not recommended.

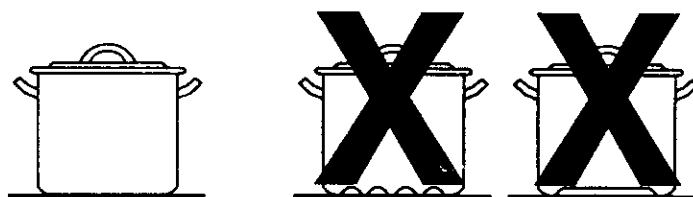

4. When canning, use recipes from reputable sources. Reliable recipes are available from the manufacturer of your canner; manufacturers of glass jars for canning, such as Ball and Kerr; and the United States Department of Agriculture Extension Service.
5. Remember, in following the recipes, that canning is a process that generates large amounts of steam. Be careful while canning to prevent burns from steam or heat.

NOTE: If your range is being operated on low power (voltage), canning may take longer than expected, even though directions have been carefully followed. The process may be improved by:

- (1) using a pressure canner, and
- (2) beginning with hot tap water when heating larger quantities of water.

CLOCK AND TIMER

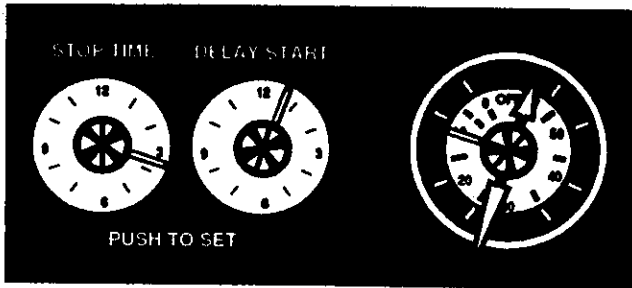

TO SET THE CLOCK:

Push In and turn the Clock Knob clockwise to set the correct time of day.

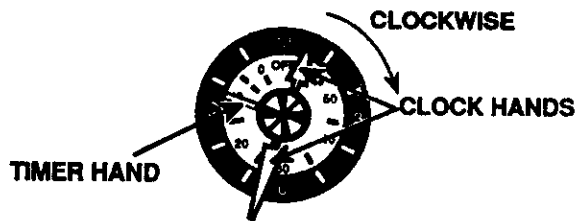

As you turn the knob you will notice that the Timer hand will turn as well. When you have set the correct time of day, turn the Timer hand to the OFF position.

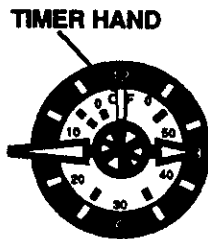

TO SET THE TIMER:

Turn the Timer hand counterclockwise without pushing in, until you have reached the desired time you will need.

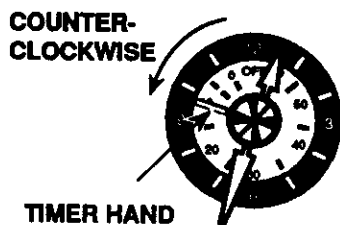

When the timer has counted down to "0" a buzzer will sound, alerting you the time is up. Turn the Timer hand to OFF.

NOTE:

The timer is a reminder. It will not control the oven operations.

OVEN COOKING

GENERAL RULES

- When cooking a food for the first time in your new oven, use time given on recipes as a guide. Your new oven has been set correctly at the factory and is apt to be more accurate than the oven it replaced. After you have used your oven for awhile, if you feel your oven should be hotter or cooler, you can adjust it yourself. See **TEMPERATURE ADJUSTMENTS** in this manual.
- **NO PEEKING** — Opening the door too often to check food during baking will allow heat loss and may cause poor baking results.
- There may be some odor when the oven is first used. This is caused by the heating of new parts and insulation.
- Do not cover an entire oven rack with foil. The foil can block normal heat flow and cause poor baking results. Do not place any foil directly above the bake element. Foil used on the oven bottom under the element may damage the oven surface; therefore, it should not be used.

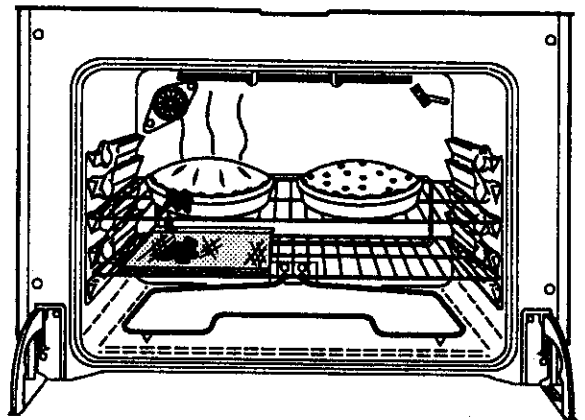

OVEN COOKING (continued)

PREHEATING

- When recipes require preheating, have food nearby before you open the oven door. If the oven door is allowed to remain open for more than a brief time, the preheat temperature will be lost.
- Let the oven preheat thoroughly before cooking baked products. Listen for preheat notification tone (if equipped) or watch for the Indicator light to go off. If your range does not have either of these features, preheat for 10 minutes and put the food in the oven.

BAKEWARE

- Cookies should be baked on flat cookie sheets without sides to allow the air to circulate properly.

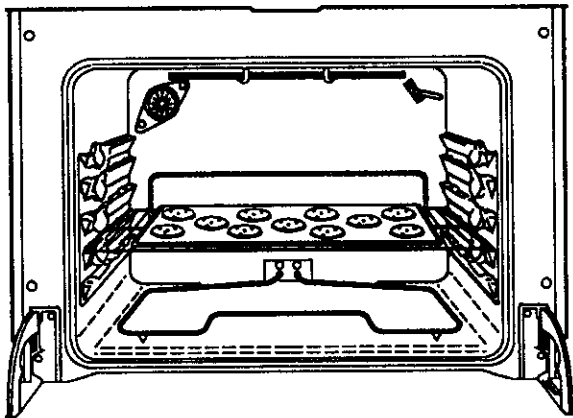

- Cakes, muffins, and quick breads should be baked in shiny pans — to reflect the heat — because they should have a light golden crust. Be sure the underside of the pan is shiny, too. Darkened undersides will absorb the heat and may cause over-browning on the bottom of your food.
- Yeast breads and pie crusts should be baked in glass or dull (non-shiny) pans — to absorb the heat — because they should have a brown, crisp crust.
- Oven temperatures should be reduced 25 degrees below recommended temperatures if exterior of pans are dark non-stick, darkened by age or oven proof glass.

BAKING

- Always follow recipe carefully.
- Measure ingredients properly.
- Use proper pan and rack placement to obtain the best cooking results.

NOTE:

YOUR OVEN HAS FOUR (4) RACK POSITIONS. THE TOP LEVEL IS ONLY A GUIDE; IT CANNOT BE USED AS A RACK POSITION!

TOP LEVEL: GUIDE ONLY!

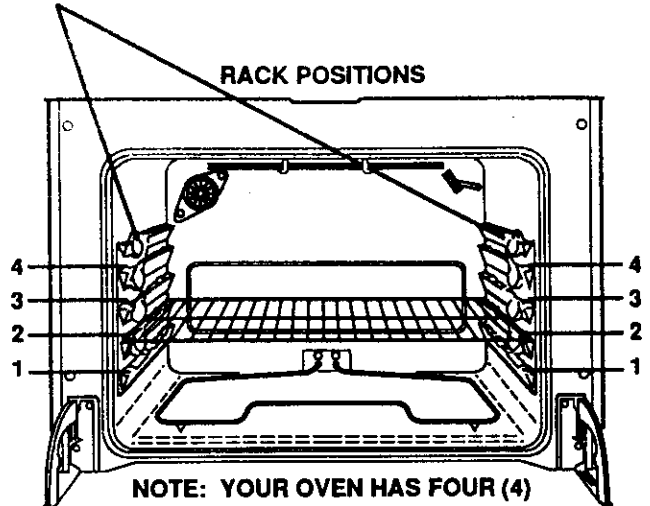

- Place pans on the oven racks with 1" to 1 1/2" of air space on all sides of each pan. Avoid overcrowding the oven.

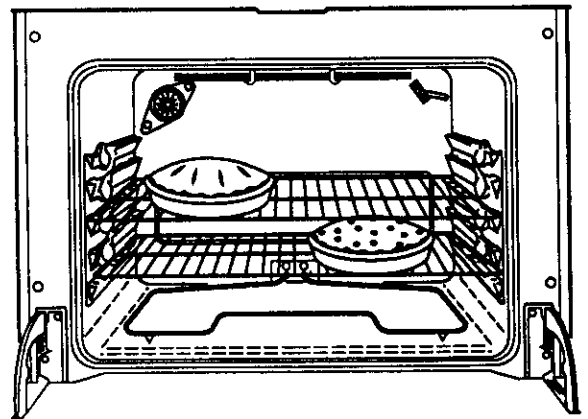

- When baking several items, stagger pans so that no pan is directly above another.
- Pans too close to each other, to oven walls or to the oven bottom block the free movement of air. Improper air movement causes uneven browning and cooking.

OVEN CONTROLS

TO SET BAKE:

1. Set the **OVEN SET KNOB** to **BAKE** for baking.
2. Set the **OVEN TEMP KNOB** to the desired temperature for baking.

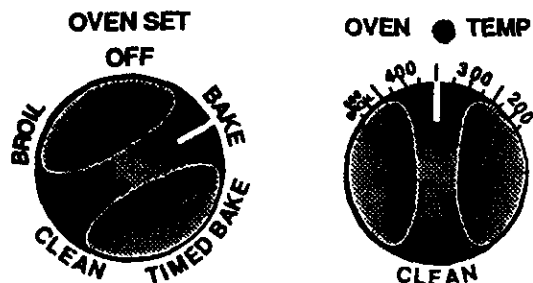

TIMED BAKING:

This function allows you to have the oven turn on and off automatically by setting the desired times you choose for cooking.

You may choose to have the oven cook now and turn off automatically at a later time - this is called **AUTOMATIC OVEN OFF**.

Should you want the oven to automatically begin cooking at a later time and then turn off - this is called **OVEN AUTOMATIC ON, AUTOMATIC OFF**.

Please follow the instructions below for the timed operation you desire to use.

TO SET AUTOMATIC OVEN OFF:

1. Be sure the clock is showing the correct time of day.

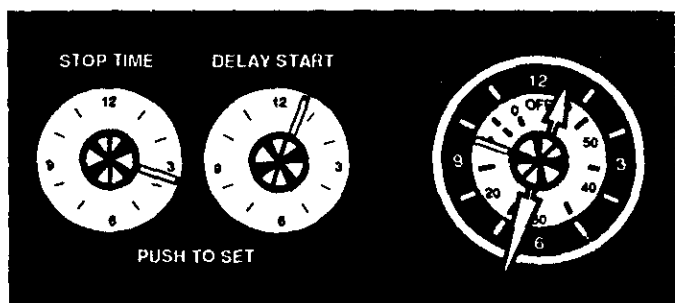

2. Turn the **OVEN SET KNOB** to **TIMED BAKE** (the oven on indicator light will glow).

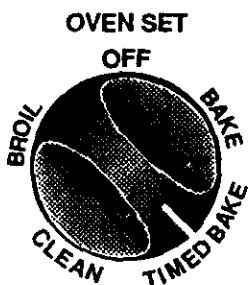

3. Push In and turn the **STOP TIME KNOB** to the time you want the oven to stop cooking.



The **DELAY START** dial should show the same time as the **CLOCK**.

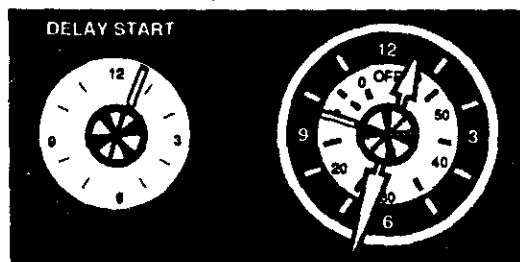

4. Turn the **OVEN TEMP KNOB** to the temperature you want to use.

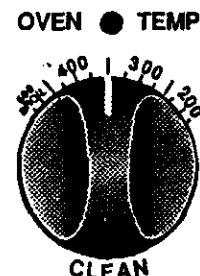

5. When **BAKING** is finished the oven will automatically turn off. Turn the **OVEN SET KNOB** to the "OFF" position.

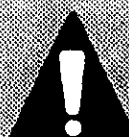

CAUTION:

Foods that are highly perishable, such as milk, eggs, fish, stuffings, poultry and pork, should not be allowed to sit out for more than one hour before or after cooking. Room temperature promotes the growth of harmful bacteria. Be sure that the oven light is off because heat from the bulb will speed harmful bacteria growth.

NOTE: You should consider that food will continue to cook after controls turn off unless you remove the food immediately.

OVEN CONTROLS (continued)

TO SET OVEN AUTOMATIC ON/OFF:

1. Be sure the clock is showing the correct time of day.

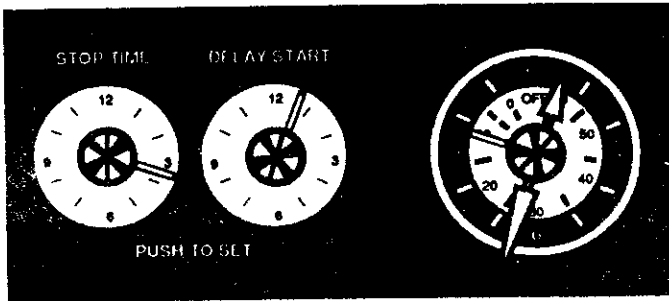

2. Turn the **OVEN SET KNOB** to **TIMED BAKE** (the oven on indicator light will glow).

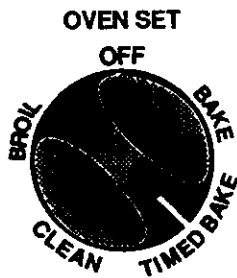

3. Push in and turn the **DELAY START KNOB** to the time you want the oven to start cooking.

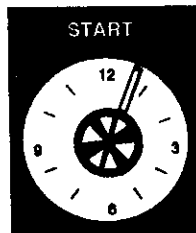

4. Push in and turn the **STOP TIME KNOB** to the time you want the oven to stop cooking.



5. Turn the **OVEN TEMP KNOB** to the temperature you want to use.

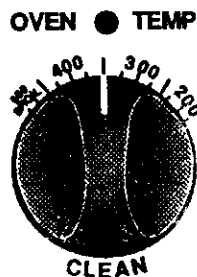

6. When **TIMED BAKING** is finished, turn the **OVEN SET KNOB** to the "OFF" position.

ROASTING

Roasting is cooking tender cuts of meats with dry heat. It is not necessary to preheat your oven before roasting.

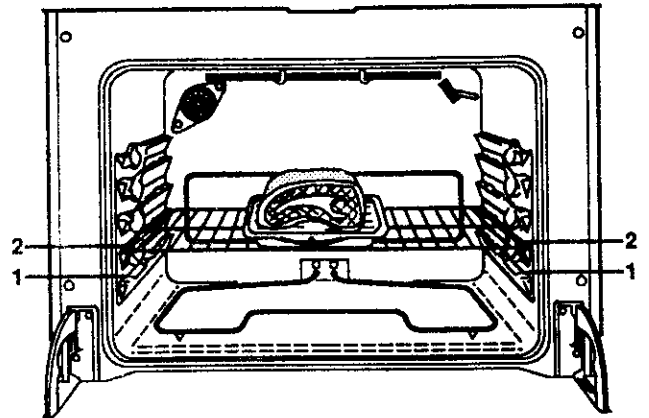

GENERAL ROASTING INSTRUCTIONS

1. Place meat (fatty side up) on a roasting rack or in a shallow pan about the same size of the meat.
2. Place pan in No.1 or No. 2 rack position.
3. Turn the **OVEN SET KNOB** to **BAKE** for baking.
4. Turn the **OVEN TEMP KNOB** to the desired temperature for roasting.

BROILING

BROILING TIPS

Please note:

Your oven door should be open to the broil stop position while broiling.

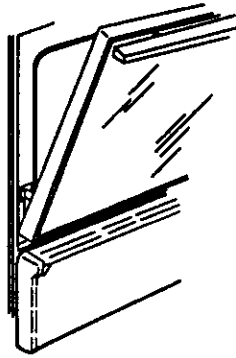

- Use only the broiler pan and grid that came with your range for broiling. They are designed for proper drainage of fat and liquids and help prevent spatter, smoke or fire.
- Do not preheat when broiling. For even broiling on both sides, start the food on a cold pan.
- Trim the outer layer of fat from steaks and chops. Silt the fatty edges to keep the meat from curling.
- For maximum juiciness, salt the first side just before turning the meat. Salt the second side just before serving.
- Brush chicken and fish with butter several times as they broil. When broiling fish, grease the grid to prevent sticking. Broil with skin side down. It is not necessary to turn fish.
- Never leave a soiled broiler pan in the range. Grease in the pan may smoke or burn the next time the oven is used.
- Be sure you know the correct procedure for putting out a grease fire. See the section on safety.

CAUTION:

Do not cover the entire broiler grid with foil (mold foil tightly to grid and cut slits in foil to align with slits in the grid). Poor drainage of hot fat may cause a broiler fire.

If a fire starts, close the oven door and turn controls OFF. If fire continues, throw baking soda on the fire. Do not put water on the fire.

- Do not lock the oven lock/unlock handle while broiling. The oven lock/unlock handle is used for self-clean only.

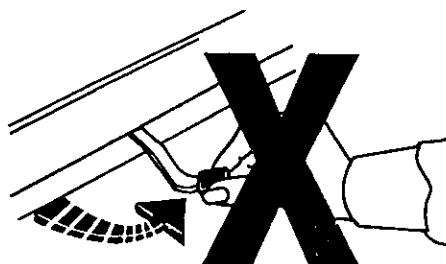

POSITIONING BROILER PAN

Broiling is cooking by direct heat from the broil element. Tender cuts of meat or marinated meat should be selected for broiling. For best results steaks and chops should be at least 3/4" thick.

After placing food on the broiler pan and grid, put the pan on an oven rack in the proper position. The recommended rack position and cooking time can be found in the chart below. If your range is connected to 208 Volts you may wish to use a higher rack position.

The closer the food is to the broil element, the faster the meat browns on the outside, yet stays red to pink in the center. Moving the meat farther away from the element lets the meat cook to the center while browning outside. Side one should be cooked 1 - 2 minutes longer than side two.

Food	Rack Position 4 = Highest 1 = Lowest	Total Time (minutes)
Steak - 1" Thick		
Rare	4	9-11
Medium	3	13-15
Well Done	3	21-23
Ground Beef Patties		
Medium-1" Thick	3	16-18
Medium-1/2" Thick	4	7-9
Lamb Chops - 1" Thick	3	18-21
Pork Chops - 1" Thick	3	27-29
Pork Chops - 1/2" Thick	3	16-18
Ham Slice - 1/2" Thick	3	11-12
Fish (Fillets)	3	11-13
Chicken (Pieces)	2	45-55
Frankfurters	3	8-11
Bacon	3	9-11

This chart is a general guide. The size, weight, thickness, and starting temperature of the food, as well as your own personal preference, will affect the cooking time. Times in the chart are based on the food being at refrigerator temperature. The U.S. Department of Agriculture notes that meats cooked rare are popular, but cooking meat to only 140°F may allow some poisoning organisms to survive.

TO SET BROIL:

1. Set the OVEN SET KNOB to BROIL.
2. Set the OVEN TEMP KNOB to BROIL.

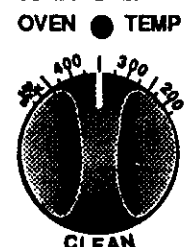
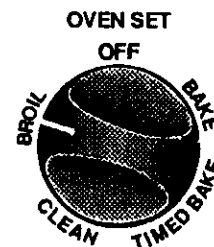

THE SELF-CLEAN CYCLE (3 HOURS - NORMAL CLEAN TIME)

BEFORE A CLEAN CYCLE

1. Remove the broiler pan and grid, oven racks, all utensils and any foil that may be in the oven. Do not try to clean utensils or any other objects in the oven during a self-clean cycle. If oven racks are left in the range during a clean cycle, they will darken, lose their luster and become hard to slide. If you choose to leave the racks in the oven, you can polish the edges of the racks with steel wool and apply a small amount of vegetable oil to the rack edges after the self-clean cycle. This will make the racks easier to slide.

2. Soil on the oven front frame, under the front edge of the cooktop, the door liner outside the door gasket and the front edge of the oven cavity (about 1" into the oven) will not be cleaned during a clean cycle (see illustration below). Clean these areas by hand before starting a clean cycle.

Use hot water with a soap-filled steel wool pad. We recommend a cleanser such as 'Soft Scrub®' brand or a similar cleaning product to keep white surfaces looking clean and new. After cleaning, rinse well to help prevent a brown residue from forming when the oven is heated. Buff these areas dry with a dry cloth.

OVEN LIGHT -

To prolong the life of the bulb, be sure the oven light is OFF during Self-Clean .

FRONT FRAME

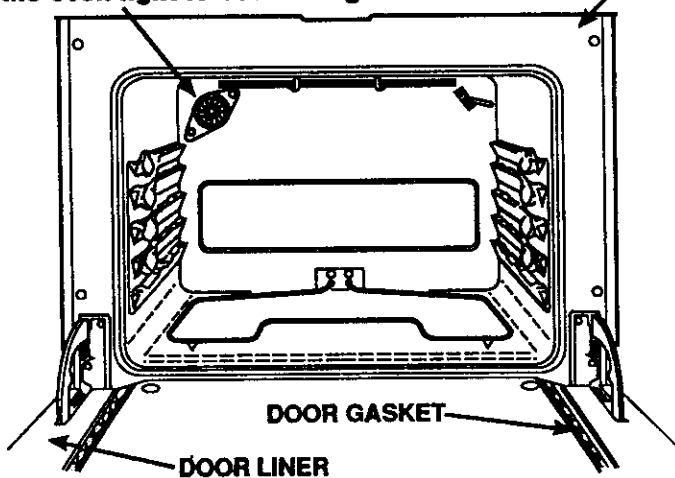

3. Wipe up heavy spillovers on the oven bottom. Too much soil may cause smoking during the clean cycle.
4. Do not rub the door gasket. The fiberglass material of the gasket has an extremely low resistance to abrasion. An intact and well fitting oven door gasket is essential for energy efficient oven operation and good baking results. If you notice the gasket becoming worn, frayed or damaged in any way or if it has become displaced on the door, you should replace the seal.

Please Note:

The door gasket is designed to have a 5" to 6" gap at the bottom of the oven door. This is to allow for proper air circulation.

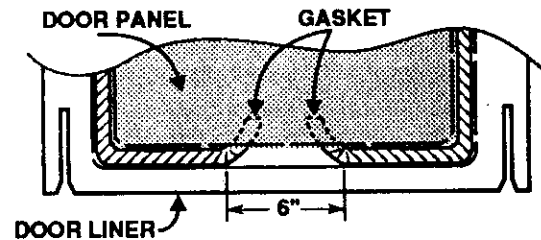

TO SET A CLEAN CYCLE

1. If your handle is hidden, lift the cooktop and pull the handle out as far as it will come.

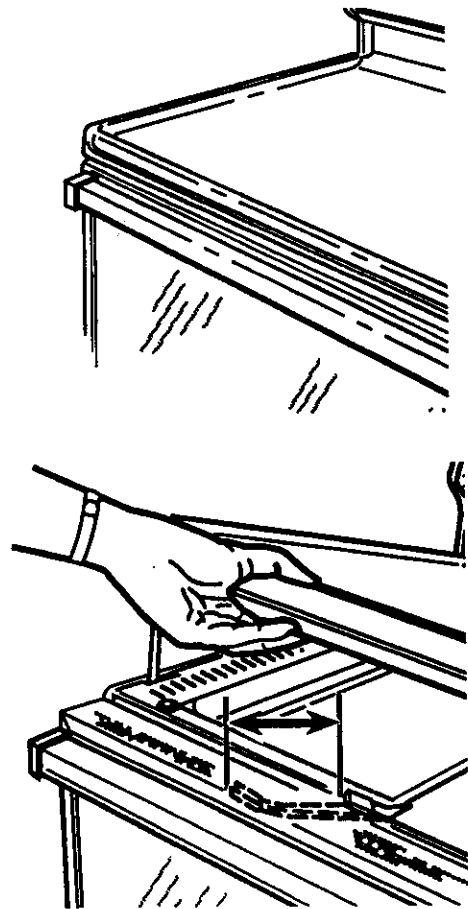

2. Follow the steps under **BEFORE A CLEAN CYCLE**.
3. Make sure the Clock is showing the correct time of day.
4. Turn **OVEN SET KNOB** to **CLEAN**.

Turn **OVEN TEMP KNOB** counterclockwise to **CLEAN**. Turn the knob all the way until it stops.

(Self-Clean continued on next page...)

SELF-CLEAN (continued) TO SET A CLEAN CYCLE

5. Set **DELAY START KNOB** on the clock to the present time of day.
6. Set the **STOP TIME KNOB** to the time of day when you want the clean cycle to end.
7. Slide the door lock/unlock handle all the way to the right to lock the door. You may need to press on the door slightly to get it to lock.

TO LOCK:

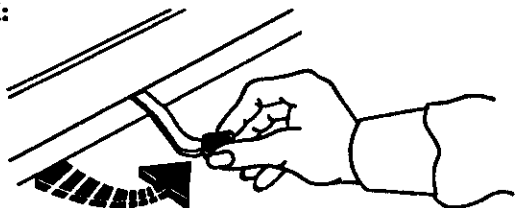

Make sure the oven light is off during the Clean cycle, to prolong the life of the bulb.

TO INTERRUPT A CLEAN CYCLE:

1. Turn **STOP TIME KNOB** to the current time of day.
2. Allow sufficient time for cooling. **The oven door will unlock only after the temperature is below locking temperature.**
Do not force the door lock handle. Slide door lock/unlock handle to left to unlock door.

WHEN A CLEAN CYCLE IS FINISHED:

1. **STOP TIME** will be the same as the time of day.
2. Allow sufficient time for cooling. **Do not force the door lock handle.** Slide door lock/unlock handle to left to unlock door.

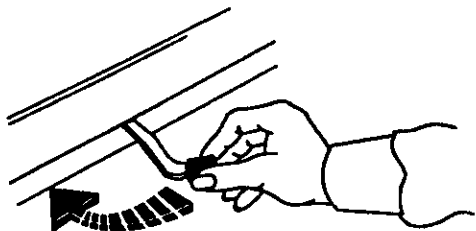

3. Turn **OVEN SET KNOB** to "OFF". Turn **OVEN TEMP KNOB** clockwise.

TO SET DELAYED CLEAN CYCLE:

NOTE: Clock must be set to correct time of day.

1. Turn **OVEN SET KNOB** to **CLEAN**.
2. Set the **DELAY START TIME KNOB** to the time of day when you want cleaning to begin.
3. Set the **STOP TIME KNOB** to the time of day when you want the clean cycle to end.
4. Turn **OVEN TEMP KNOB** counterclockwise to **CLEAN**. Turn the knob all the way until it stops.
5. Slide the door lock/unlock handle all the way to the right to lock the door.

After cleaning ends, wait about 30 minutes for oven to cool. Turn **OVEN SET KNOB** and **OVEN TEMP KNOB** to **OFF**. When oven has cooled, slide door lock/unlock handle to the left.

Make sure the handle is in the unlocked position and raise the cooktop.

Move the handle slowly to the left to ensure it is as far to the left as it will go.

Push the handle back into the latch cover as far as it will go.

Lower the cooktop.

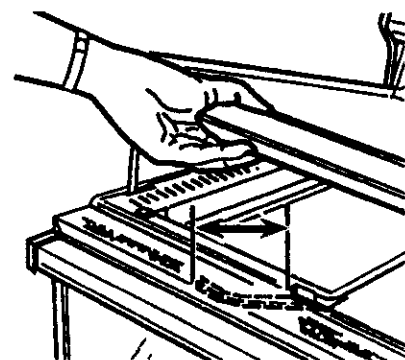

AFTER A CLEAN CYCLE

After a clean cycle, you may notice some white ash in the oven. Just wipe it up with a damp cloth.

If white spots remain, scrub them with a soap-filled steel wool pad. Be sure to rinse thoroughly with a white vinegar and water mixture. These deposits are usually a salt residue that cannot be removed by the clean cycle.

If the oven is not clean after one clean cycle, the cycle may be repeated.

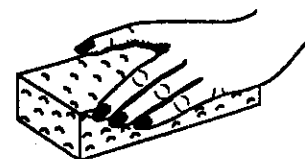

CLEANING TIPS

PART	CLEANING MATERIALS	REMARKS
CONTROL PANEL	Detergent, warm water, soft cloth	Do not use abrasive cleaners, steel wool, or plastic scouring pads. Dry thoroughly after cleaning.
SELF-CLEANING OVEN FINISH	Detergent, warm water and/or soap-filled steel wool pad Do not use oven cleaner in or around any part of the oven	Rinse well after cleaning. Cleaning inside the oven need only be done as an optional touch-up between self-clean cycles. See the self-cleaning section for more information.
OVEN RACK	Detergent, warm water, scouring pad or soap-filled steel wool pad or oven cleaner	Remove from oven to clean. Rinse thoroughly. Racks are dishwasher safe.
BROILER PAN AND GRID	Detergent, warm water, soap-filled scouring pad, commercial oven cleaner or paper towels. Let pan and grid soak for a few minutes. Rinse or scour as needed. Grid and pan may be washed in a dishwasher.	Remove soiled pan from oven to cool. Drain fat or drippings. Fill pan with warm water. Sprinkle grid with detergent and cover with damp cloth while cleaning. Remove stubborn soil with paste of baking soda and water. Do not use abrasive cleaners. Rinse thoroughly. Door can be removed; see removable parts section.
GLASS	Glass cleaner and paper towels. If you need additional cleaning for spotting, wash with equal parts white vinegar and warm water. Rinse well and dry. abrasive cleaners. Rinse thoroughly. Door can be removed; see removable parts section.	The oven door should be completely open when cleaning the top edge. Do not allow water to run down inside vent openings in door while cleaning. Remove stubborn soil with paste of baking soda and water. Do not use
PORCELAIN ENAMEL COOKTOP	Ammonia or abrasive cleaners and scouring pad use a dry paper towel or cloth to wipe it up right away. When the surface has cooled, wash and rinse. For other spills, such as fat splatterings, wash with soap and water when cooled and then rinse. Polish with a dry cloth.	Clean after each spillover. If acidic foods (such as sauerkraut or sauces with vinegar or lemon juice) should spill on the cooktop,
PAINTED SURFACES, FRONT OF DRAWER, SIDES OF RANGE	Soap and water, damp cloth, paper towel basting materials, etc.) should spill on the range while it is hot, use a dry paper towel or cloth to wipe it up right away. When surface has cooled, wash and rinse. For other spills, such as fat splattering, etc., wash with soap and water when cooled, then rinse. Polish with a dry cloth.	Do not use oven cleaners, cleansing powders or harsh abrasives. These might scratch the surface. If acids (marinades, tomato sauces,
BAKE AND BROIL ELEMENT	DO NOT CLEAN NOTE: The bake element can be lifted gently to clean the oven floor. If spillover, residue or ash accumulates around the bake element, gently wipe the cooled element with warm water.	Any soil will burn off when the unit is heated.
CHROME DRIP BOWLS		Bowls can permanently discolor if exposed to excessive heat or if soil is allowed to bake on.
BROWN FOOD STAINS	Detergent and water, plastic scouring pads, mild abrasive cleaners, soap-filled scouring pads, ammonia	After each use, wash, rinse and dry to prevent difficult soils. If heavily soiled, place an ammonia-soaked paper towel on stains to loosen soil, then gently scrub with plastic scouring pad.
BLUE/GOLD HEAT STAINS	Metal Polish These stains are caused by overheating, normally occur over a period of time, and usually are permanent. To minimize: 1. Avoid excessive use of the high heat setting. Use it to start cooking, then lower the heat setting to finish cooking. 2. Use flat bottom pans that do not extend more than two inches from the surface element.	

REMOVABLE OVEN RACKS

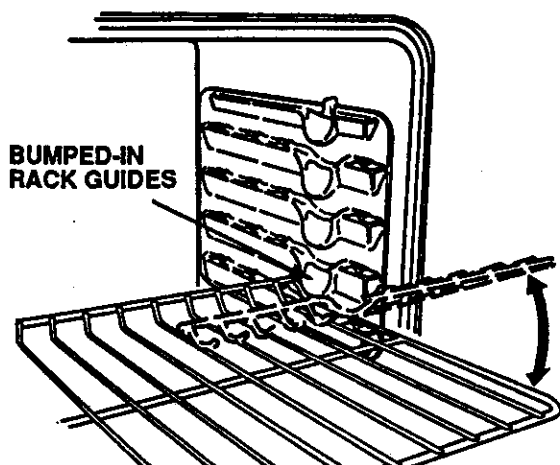

Be careful not to scratch the oven finish when installing or removing oven racks.

To install:

1. Set the raised back edge of the rack on a pair of rack guides.
2. Push the rack in until you reach the bump in the rack guide, then lift the front of the rack and push the rack all the way in.

To remove:

1. Pull the oven rack out, then up.

NOTE:

The racks are designed with stop locks. When the racks are placed correctly on the rack support and extended from the oven, the stop lock prevents the racks from tilting when you are removing food from the racks or placing food on them.

REMOVABLE OVEN DOOR

STOP (BROIL) POSITION

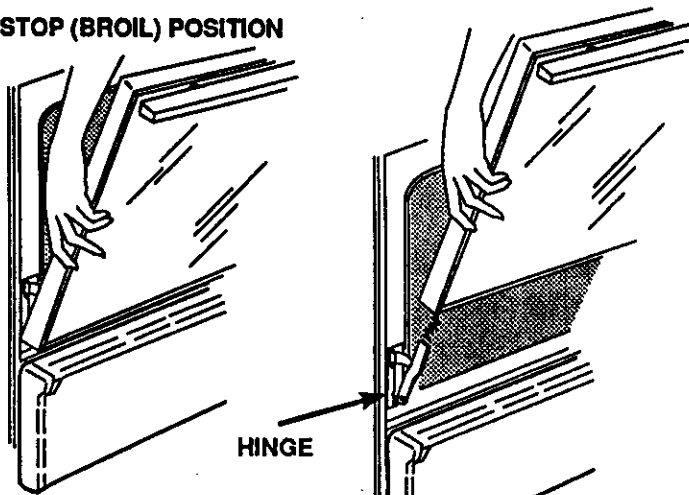

To remove:

1. Open the door to the stop position (see illustration).
2. Grasp the door at each side and lift up and off the hinges. **DO NOT** lift the door by the handle.

NOTE: When the door is removed and hinge arms are at stop position, do not bump or try to move the hinge arms. The hinges could snap back causing an injury to the hands or damage to the porcelain on the front of the range. Cover the hinges with toweling or empty towel rolls while working in the oven area.

To replace:

1. Hold the door over the hinges with the slots at the bottom edge of the door lined up with the hinges. **The hinge arms must still be in the stop position.**
2. Slide the door down onto the hinges as far as it will go and close the door.

REMOVABLE STORAGE DRAWER

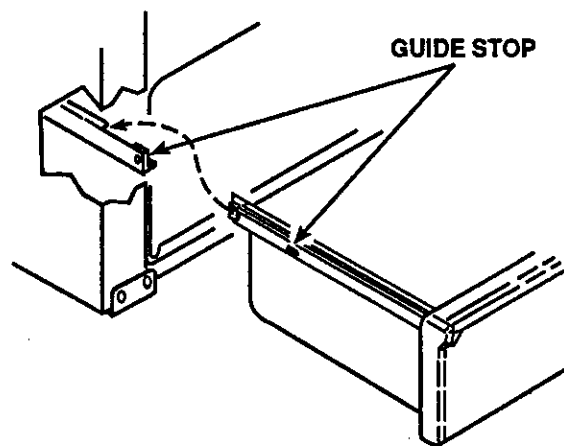

This drawer gives you space for keeping cookware and bakeware. Plastics and flammable material should not be kept in this drawer.

Do not overload the storage drawer. If the drawer is too heavy, it may slip off the track when opened. To open the drawer, grasp the center of the handle and pull straight out.

To remove: Pull drawer straight out and lift over the guide stops.

To replace: Lift over the guide stops and slide drawer into place.

REMOVABLE KNOBS

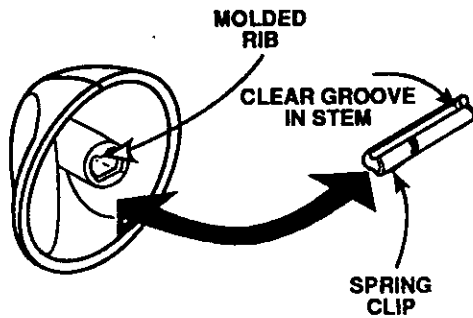

All control knobs may be removed for easy cleaning by pulling the knob straight off the stem. Be sure that the knob is in the OFF position before removal.

Hint: Slip a thin cloth (such as a handkerchief) or a piece of string under and around the knob edge and pull up.

Caution: Read these instructions carefully before replacing the knobs. Replacing the knobs improperly will damage the knobs and the spring clips on the stems. If this happens, the knobs will fit loosely.

To replace the knob:

1. The knob stem has a groove in each side. The groove on one side has a spring clip. The other groove is clear (see illustration).
2. Check the inside of the knob and find the molded rib.
3. Replace the knob by fitting the molded rib inside the knob into the clear groove on the stem.

Note: Be sure to replace knobs on the correct stems.

REPLACING THE OVEN LIGHT

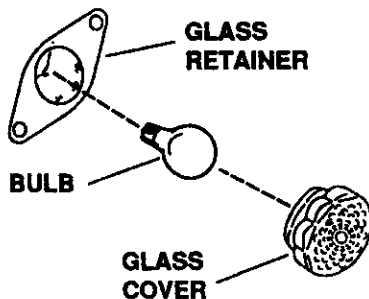

Be sure that the light switch is in the off position. Do not touch hot oven bulb. Do not touch oven bulb with wet hands. Do not wipe oven light area with wet cloth.

Never touch the electrically live collar on the bulb when replacing it.

Electrical power must be shut off if you have to replace a broken bulb.

1. Unscrew glass cover and remove.
2. Replace the bulb with a 40 watt appliance bulb.
3. Replace the cover.

Note: We recommend you use a 40 watt appliance bulb that is no longer than 3 1/2".

LIFT-UP COOKTOP

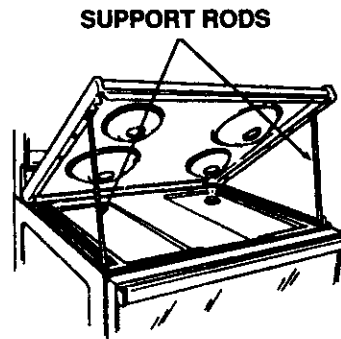

The cooktop can be raised so the area underneath can be cleaned.

Raise the front of the cooktop until the support rods snap into position to hold the cooktop.

To lower cooktop, push in on the front of the supports while lowering top.

Porcelain enamel can chip if dropped. Handle porcelain enameled cooktops carefully.

REMOVABLE COOKTOP UNITS

Do not put the element into water. It cleans itself when heated during normal use.

Be sure all cooktop unit control knobs are turned off and elements are cool before you remove or replace a cooktop unit.

To remove:

1. Grasp element, tilt it upward slightly to clear the bowl, then pull away from the receptacle. The element will not sit level when replaced if it is forced too far upward when removed. Lift out the bowl.

IMPORTANT: Never operate a cooktop element without the bowl in place. This can cause scorching of the cooktop, burning of wiring insulation and loss of energy.

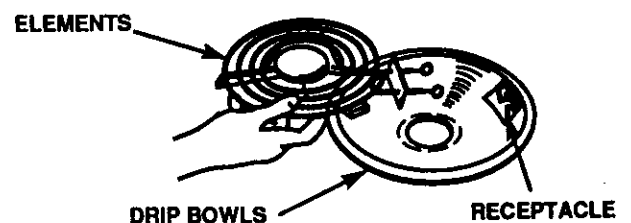

Do not lift plug-in unit more than 1". If you do, it may not lie flat on the drip bowl when you plug it back in.

Repeated lifting of the plug-in unit more than 1" above the drip bowl can permanently damage the receptacle.

To replace:

1. Replace the bowl. Be sure the receptacle is showing in the bowl opening.
2. Slide the plug of the element firmly into the receptacle and lower the element into place.

BEFORE CALLING FOR SERVICE

Save time and money — Check this list before you call for service.

To eliminate unnecessary service calls, first, read all the instructions in this manual carefully. Then, if you have a problem, always check this list of common problems and possible solutions before you call for service.

If you do have a problem you cannot fix yourself, call your nearest Sears Store or Service Center for help. When calling, have this manual, the Repair Parts List, your model number, serial number and purchase date handy.

PROBLEM	POSSIBLE CAUSE	DON'T CALL FOR SERVICE UNTIL YOU CHECK
<ul style="list-style-type: none"> • RANGE DOES NOT WORK; TOTALLY INOPERATIVE 	<ul style="list-style-type: none"> • No power to range 	<ul style="list-style-type: none"> • Check household circuit breaker or fuse. • Check cord (if equipped) to be sure it is plugged in.
<ul style="list-style-type: none"> • OVEN DOES NOT HEAT; COOKTOPELEMENTS OK 	<ul style="list-style-type: none"> • Oven control set incorrectly 	<ul style="list-style-type: none"> • Check oven control.
<ul style="list-style-type: none"> • COOKTOP DOES NOT WORK; OVEN OK 	<ul style="list-style-type: none"> • Element(s) unplugged • Improper operation of control 	<ul style="list-style-type: none"> • Check element connections by removing and re-plugging element(s) firmly. • Be sure knob is pushed in while turning.
<ul style="list-style-type: none"> • FOODS DO NOT BAKE PROPERLY 	<ul style="list-style-type: none"> • Oven not preheated long enough • Improper rack or pan placement • Oven vent blocked or covered • Improper use of foil • Improper temperature setting for utensil used • Recipe not followed • Range and oven rack not level • Using improper cookware 	<ul style="list-style-type: none"> • Be sure to preheat until preheated indicator light goes out. • Maintain uniform air space around pans and utensils; see cooking hints section. • Drip bowl for right rear element must have hole in the center over the oven vent. • Foil use not recommended. • Reduce temperature 25° for glass or dull/darkened pans. • Is recipe tested and reliable? • Check the installation instructions for leveling instructions. • See cooking hints.
<ul style="list-style-type: none"> • OVEN TEMPERATURE SEEMS INACCURATE 	<ul style="list-style-type: none"> • Oven is too hot or too cool for your baking preference 	<ul style="list-style-type: none"> • See adjustments described in TEMPERATURE ADJUSTMENTS section.
<ul style="list-style-type: none"> • FOODS DO NOT BROIL PROPERLY 	<ul style="list-style-type: none"> • Oven door closed • Improper rack position * Low voltage (208) • Oven preheated • Improper utensil used • Improper broiling time 	<ul style="list-style-type: none"> • Open door to broil stop position. • Check broil pan placement; see Broiling section. • You may need to use a higher rack position. • Do not preheat when broiling. • Use broiler pan and grid supplied with range. • Check broiling chart.
<ul style="list-style-type: none"> • OVEN SMOKES 	<ul style="list-style-type: none"> • Dirty oven • Broiler pan full of grease left in 	<ul style="list-style-type: none"> • Check for heavy spillover. • Check pan and grid after each use.
<ul style="list-style-type: none"> • OVEN DOOR ACCIDENTALLY LOCKED WHILE BAKING OR BROILING 	<ul style="list-style-type: none"> • Oven has heated to high temperatures 	<ul style="list-style-type: none"> • Turn Oven Set Knob to OFF. Allow oven to cool until lock handle slides easily. Never force door lock/unlock handle.

BEFORE CALLING FOR SERVICE (continued)

PROBLEM	POSSIBLE CAUSE	DON'T CALL FOR SERVICE UNTIL YOU CHECK
<ul style="list-style-type: none"> • OVEN WILL NOT SELF-CLEAN OR POOR SELF-CLEANING RESULTS 	<ul style="list-style-type: none"> • Controls set Incorrectly • Clean cycle Interrupted too soon • Oven too dirty 	<ul style="list-style-type: none"> • See self-clean instructions. • Heavily soiled ovens require a 3 1/2 hour clean cycle. • Heavy spillovers should be removed before setting clean cycle. Repeat clean cycle.
<ul style="list-style-type: none"> • OVEN DOOR WILL NOT UNLOCK 	<ul style="list-style-type: none"> • Clean cycle not complete • Door accidentally locked while baking or broiling 	<ul style="list-style-type: none"> • Oven must cool below lock temperature. • Turn oven control to OFF. Wait until oven cools and door will unlock. Do not force the door lock.
<ul style="list-style-type: none"> • OVEN LIGHT DOES NOT WORK 	<ul style="list-style-type: none"> • Light switch in OFF position • Light bulb burned out 	<ul style="list-style-type: none"> • Check switch setting; see operating instructions. • Check or replace light bulb; see removable parts section of this manual.
<ul style="list-style-type: none"> • OVEN EMITS ODOR 	<ul style="list-style-type: none"> • Oven insulation may emit odor during first few usages • Failure to wipe out excessive soil during self-cleaning 	<ul style="list-style-type: none"> • Put oven through a self-clean cycle to speed up process of odor "wearing off." • Wipe excessive soil before beginning self-clean cycle.

THERMOSTAT ADJUSTMENTS

The temperature in your new oven has been set correctly at the factory, so be sure to follow the recipe temperatures and times the first few times you bake in your new oven.

We do not recommend the use of inexpensive thermometers, such as those found in the grocery store, to readjust the temperature setting of your new oven. These thermometers can vary by 20° - 40°F. Your oven has been preset to maximize cooking efficiency.

If you think the oven should be hotter or cooler, you can adjust it yourself. To decide how much to change the temperature, set the oven temperature 25°F higher or lower than the temperature in your recipe, then bake. The results of this "test" should give you an idea of how much the temperature should be changed.

To adjust knob:

1. Turn OVEN TEMP KNOB to OFF and remove the knob by pulling straight off.
2. Look at the back of the knob. The arrow pointing to the center of the bottom screw indicates the original factory setting.

3. Use a screwdriver to loosen the two screws about 2 turns each.
4. Hold the knob handle (A on illustration) while turning the disk (B on illustration) in the desired direction to increase or decrease the temperature. (See illustration below for "Self-Clean Thermostat.") As you turn, you should be able to hear clicks and feel notches or teeth. Each click or notch is 15°F. You can turn up to 2 clicks or notches in either direction.
5. When you reach the desired adjustment, retighten both screws.

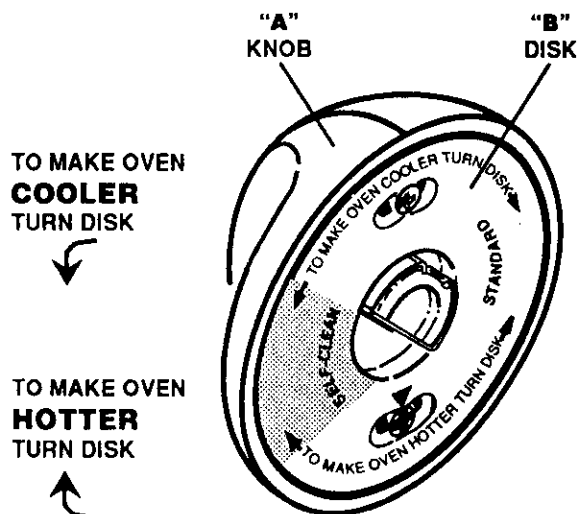

KENMORE ELECTRIC RANGE WARRANTY

Dear Customer:

Our constant efforts are directed toward making sure your new Kenmore Range will arrive at your home in perfect condition and will give you proper performance. As part of these efforts, we feel it is our responsibility to provide you with this warranty for your range.



FULL ONE YEAR WARRANTY ON THE FUNCTIONING OF ALL PARTS EXCEPT GLASS PARTS

If, within one year from the date of installation, any part, other than a glass part, falls to function properly due to a defect in material or workmanship, Sears will repair or replace it, free of charge.

FULL 30-DAY WARRANTY ON GLASS PARTS AND FINISH OF PORCELAIN ENAMEL, PAINTED OR BRIGHT METAL FINISHED PARTS

If, within 30 days from the date of installation, any glass part or the finish on any porcelain enamel, painted or bright metal part is defective in material or workmanship, Sears will replace the part, free of charge.

FULL 90-DAY WARRANTY ON MECHANICAL ADJUSTMENTS

For 90 days from the date of installation, Sears will provide, free of charge, any mechanical adjustments necessary for proper operation of the range, except for normal maintenance.

If the range is subjected to other than private family use, the above warranty coverage is effective for only 90 days.

WARRANTY SERVICE IS AVAILABLE BY CONTACTING THE NEAREST SEARS SERVICE CENTER/DEPARTMENT IN THE UNITED STATES

This warranty applies only while this product is in use in the United States. This warranty gives you specific legal rights, and you may also have other rights which vary from state to state.

SEARS, ROEBUCK and CO.
 Dept. 720PSO
 3333 Beverly Road
 Hoffman Estates, IL 60179

WE SERVICE WHAT WE SELL

"We Service What We Sell" is our assurance to you that you can depend on Sears for service because Sears service is nationwide.

Your Kenmore Range has added value when you consider that Sears has a service unit near you staffed by Sears trained technicians. . . professional technicians specifically trained on Sears appliances, having the parts, tools and equipment to ensure that we meet our pledge to you — "We Service What We Sell!"

TO FURTHER ADD TO THE VALUE OF YOUR RANGE, BUY A SEARS MAINTENANCE AGREEMENT.

Kenmore Ranges are designed, manufactured and tested for years of dependable operation. Yet, any modern appliance may require service from time to time. The Sears Warranty plus the Sears Maintenance Agreement provides protection from unexpected repair bills and assures you of enjoying maximum range efficiency.

Here's a comparative warranty and Maintenance Agreement chart showing you the benefits of a Sears Range Maintenance Agreement.

Years of Ownership Coverage		1st Year	2nd Year	3rd Year
1	Replacement of Defective Parts other than Porcelain or Glass	W	MA	MA
2	Mechanical Adjustment	90 DAYS W	MA	MA
3	Porcelain and Glass Parts	30 DAYS W	MA	MA
4	Annual Preventive Maintenance Check at your request	MA	MA	MA

W - Warranty MA - Maintenance Agreement

CONTACT YOUR SEARS SALESPERSON OR LOCAL SEARS SERVICE CENTER TODAY AND PURCHASE A SEARS MAINTENANCE AGREEMENT.

Kenmore® America's Best Selling Appliance Brand

Sold by SEARS, ROEBUCK AND CO., Hoffman Estates, IL 60179