

# SEARS Kenmore

## CONTENTS

### **SAFETY**

..... 1-3

### **USE AND CARE**

Your Range and Its Features .....	4
Cooktop Controls .....	5
Oven Controls .....	5
Oven Vent .....	4
Oven Cooking .....	6
Broiling .....	7
Self-Clean Cycle .....	8, 9
Cleaning Tips .....	9, 10
Removable Range Parts .....	10-12

### **BEFORE CALLING FOR SERVICE**

What to Do Before Calling for Service .....	13, 14
Thermostat Adjustments .....	14

### **WARRANTY**

MODELS 93121, 93321,  
93325

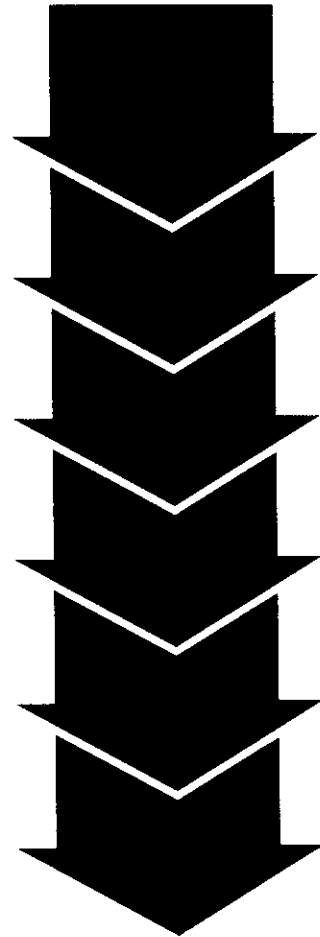

# USE • CARE • SAFETY MANUAL

IMPORTANT IMPORTANT IMPORTANT IMPORTANT IMPORTANT IMPORTANT IMPORTANT IMPORTANT IMPORTANT IMPORTANT

# IMPORTANT INSTRUCTIONS FOR YOUR SAFETY

## SAVE THESE INSTRUCTIONS

Read all instructions before using this appliance. When using electrical appliances, basic safety precautions should be followed, including the following:

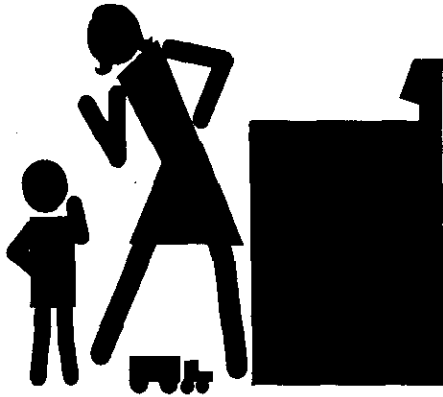

**Teach children not to play with range knobs or any other part of the range.**

**Never leave children alone or unattended where a range is in use.**

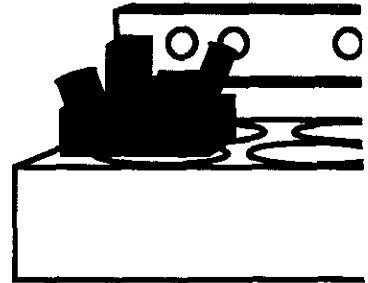

### CAUTION:

**Never store things children might want above a range.**

**Never let anyone climb, sit or stand on the open door or any other part of the range. Their weight may make the range tip over.**



**Never leave the oven door open when you are not watching the range.**

### WARNING:

**To prevent accidental tipping of the range from abnormal usage, including excess loading of the oven door, attach it to the wall or floor by installing the anti-tip bracket supplied. If the range is moved for cleaning, servicing or any reason, be sure anti-tip device is re-engaged properly when the range is replaced. Failure to take this precaution could result in tipping of the range and cause injury.**



**IMPORTANT IMPORTANT IMPORTANT IMPORTANT IMPORTANT IMPORTANT IMPORTANT IMPORTANT IMPORTANT**

To insure safety for yourself and your home, please read your Owner's Manual carefully. Keep it handy for quick easy reference. Pay close attention to the safety sections of your manual. You can recognize the safety sections by looking for the  symbol or the word "Safety".

Always keep the range area clear and free from things that will burn.

**CAUTION:**

Never store things in an oven or near cooktop elements/burners. These things may catch fire and plastic items could melt.

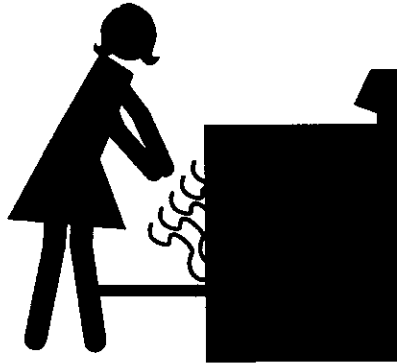

Never use your range for warming or heating a room. You could be burned or seriously injured. Such misuse could also cause damage to the range.

Never wear loose clothing when using your range. Such clothing could catch fire.



Never use a towel or other bulky cloth as a potholder. Such cloths could catch fire on a hot element/burner.

Never let pot handles stick out over the front of the range. Turn handles in so that they cannot be bumped into. Keep the handles away from other hot surface elements/burners.

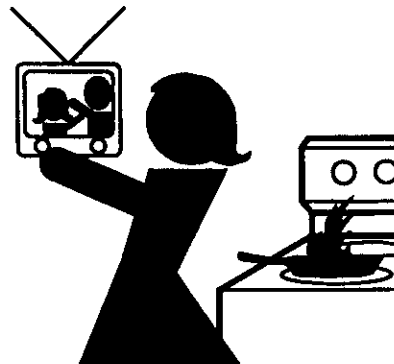

Never leave cooktop elements/burners unwatched at high heat settings. Boilovers cause smoking and greasy spillovers could catch fire.

# IMPORTANT SAFETY INSTRUCTIONS

**Keep this book for later use.**

**Be sure your range is installed and grounded properly by a qualified technician.**

**Always use care when touching surface elements, oven heating elements or inside the oven. Heating elements could be hot enough to burn you even if they are dark in color. The oven vent duct and oven door may also become hot during oven use.**

**After broiling, always take the broiler pan out of the oven and clean it. Leftover grease in the broiler pan can catch on fire next time you use the pan.**

**Always use dry potholders when removing pans from the oven. Moist or damp potholders can cause steam burns.**

**Always use care when opening oven door. Let hot air and steam out before moving food.**

**Always follow cleaning instructions in this book.**

**Always keep the range clean. Food and grease are easy to ignite. Clean the oven regularly.**

**Always keep combustible wall coverings, curtains or drapes a safe distance away from your range. Never store such items in or on your range.**

**Always keep wooden, plastic utensils, or canned food a safe distance away from your range.**

**Always keep the appliance area clear and free from things that will burn, gasoline and other flammable vapors and liquids.**

**Always remove the broiler pan and other utensils from the oven before a self-clean cycle.**

**Clean Only parts listed in the Manual.**

**Always keep dish towels, dish cloths, potholders, and linens a safe distance away from your range. Never store such items in or near your range.**

**Never heat unopened food containers. Pressure buildup may make container burst and cause injury.**

**Never leave jars or cans of fat or drippings on or near the range. Never let grease build up on your range. You can keep grease fires from starting if you clean up grease and spills after each range use.**

**Never use aluminum foil to line oven bottoms. Improper use of foil could start a fire.**

**Be sure everyone in your home knows what to do in case of a fire.**

**Read and understand this information NOW! Should you ever need it, you will not have time for reading.**

## IMPORTANT SAFETY NOTICE

The California Safe Drinking Water and Toxic Enforcement Act requires the Governor of California to publish a list of substances known to the state to cause birth defects or other reproductive harm, and requires businesses to warn customers of potential exposure to such substances.

**Never block free airflow through the oven vent.**

**Never try to move a pan of hot fat, especially a deep fat fryer. Wait until the fat has cooled.**

**Place oven racks in desired position while oven is cool. If racks must be handled when hot, do not let potholder contact hot heating element in oven.**

**Choose pots and pans with flat bottoms, large enough to cover the entire cooktop element. This will cut down the risk of setting potholders or clothing on fire with an uncovered element and waste less energy.**

**Only some kinds of glass or ceramic pans can be used for cooktop cooking. Be sure that the pan you use will not break when heated on the cooktop elements.**

**Never try to clean utensils, cookware or removable parts of your range in the oven during a self-clean cycle.**

**Never rub, move, or damage the door gasket on self-cleaning oven. The gasket is essential for a good seal. Only clean the gasket by soaking it with hydrogen peroxide, as described in the self-clean section of this manual.**

**If the self-cleaning mode malfunctions, turn off and disconnect the power supply. Have serviced by a qualified technician.**

**Never try to repair or replace any part of the range unless instructions are given in this book. All other work should be done by a skilled technician.**

**Do Not Use Oven Cleaners — No commercial oven cleaner or oven liner protective coating of any kind should be used in or around any part of the oven.**

**Never put removable heating elements in water. Do not put them in a dishwasher. Do not put them in the self-clean cycle of your oven.**

**Never use the cooktop without reflector pans or drip bowls in place. If these pans or bowls are not there during cooking, wiring or other range parts may be damaged.**

**Never clean cooktop surface when it is hot. Some cleaners produce noxious fumes and wet cloths could cause steam burns if used on a hot surface.**

## OVEN FIRE

**Do not try to move the pan.**

1. Close oven door and turn controls off.
2. If fire continues, throw baking soda on the fire.

**Never use water on a grease fire — It will only spread the flames.**

The fiberglass insulation in self-clean ovens gives off a very small amount of carbon monoxide during the cleaning cycle. Exposure can be minimized by venting with an open window or using a ventilation fan or hood.

# YOUR RANGE

**IMPORTANT:** The model and serial number of your range can be found on a tag, behind the storage drawer panel, on the left side of the range front frame.

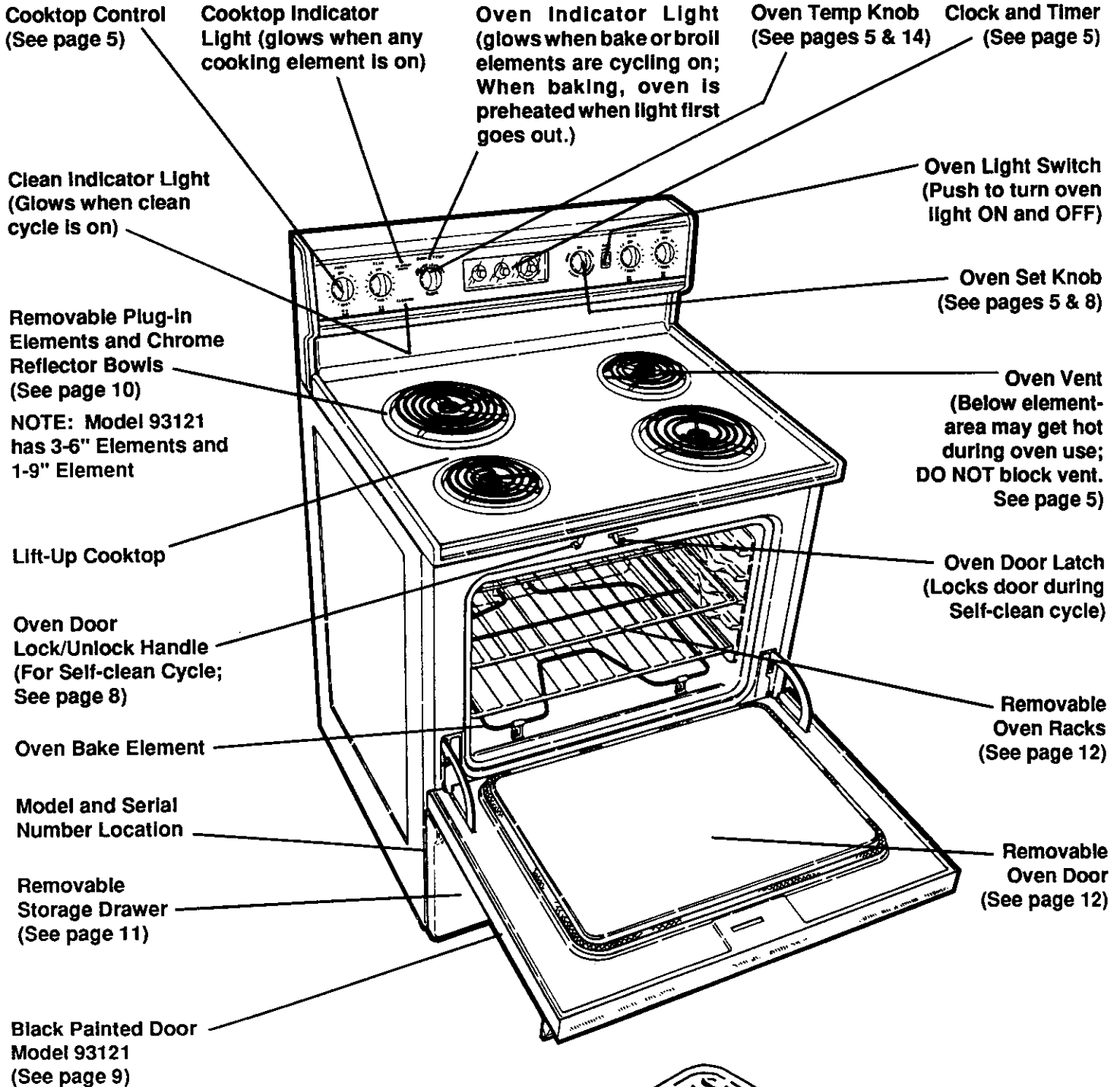

# TO START THINGS COOKING

## COOKTOP COOKING

The sign near each cooktop control knob shows which element is turned on by that knob.

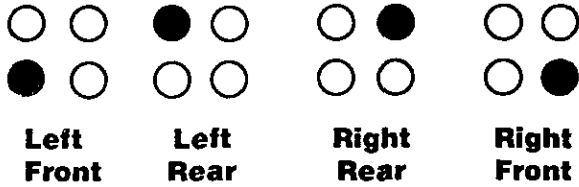

To operate cooktop controls:

1. Push to turn.
2. Set on or between marks for desired heat.

An indicator light will glow when any cooktop element is on.

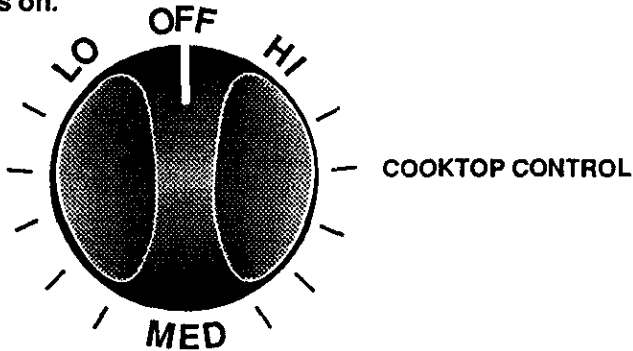

For best cooking results and energy efficient operation, you should use pans that:

- A. Have flat bottoms and straight sides.
- B. Have light handles that do not tilt pans.
- C. Are about the same size as the element.

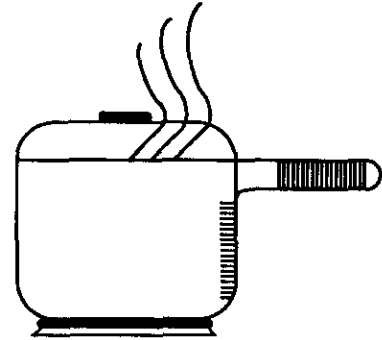



**Never line the bowls below cooktop elements with aluminum foil. Foil can block normal heat flow and damage the range. This is especially true if foil blocks the oven vent tube under the right rear cooktop element.**

## CLOCK AND OVEN CONTROLS

OVEN ● TEMP

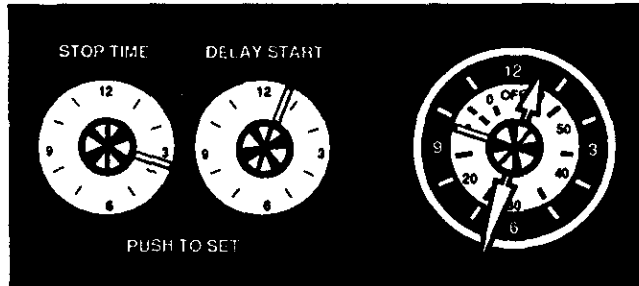
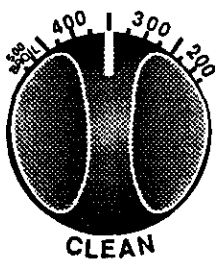

OVEN SET

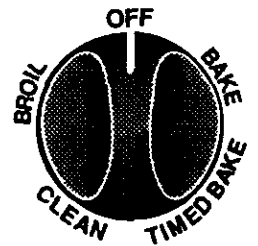

### TO SET THE CLOCK:

Push in and turn CLOCK KNOB to set time. Turn knob without pushing in to set timer hand back to OFF.

### TO SET THE TIMER:

Turn CLOCK KNOB counterclockwise without pushing in.

To turn off buzzer after time is up, reset timer hand to OFF.

**NOTE:** The timer is a reminder only and will not control the range.

### TO BAKE, ROAST OR BROIL:

Be sure that the OVEN SET KNOB is turned to BAKE for baking or roasting or BROIL for broiling.

1. Set the OVEN TEMP KNOB to desired temperature or to BROIL.

For broiling the OVEN TEMP KNOB must be set to 500 BROIL.

2. When finished, turn OVEN SET KNOB to OFF.

**NOTE:** To set an automatic oven operation, the time of day must be correct on the clock.

### AUTOMATIC OVEN OFF:

1. Turn the OVEN SET KNOB to TIME BAKE (oven indicator light will glow).
2. Push in and turn STOP TIME KNOB to set time when oven will turn off. DELAY START TIME should show same as clock.
3. Set OVEN TEMP KNOB to desired temperature.
4. When finished, turn OVEN SET KNOB to OFF.

### AUTOMATIC OVEN ON AND OFF:

1. Turn the OVEN SET KNOB to TIME BAKE.
2. Push in and turn DELAY START TIME KNOB to set time when oven will turn on.
3. Push in and turn STOP TIME KNOB to set time when oven will turn off.
4. Set OVEN TEMP KNOB to desired temperature.
5. When finished, turn OVEN SET KNOB to OFF.

# OVEN COOKING

- When cooking a food for the first time in your new oven, use time given on recipes as a guide.

Your new oven has been set correctly at the factory and is apt to be more accurate than the oven it replaced.

After you have used your oven for awhile, if you feel your oven should be hotter or cooler, you can adjust it yourself. See THERMOSTAT ADJUSTMENTS in this manual.

- Always follow recipe carefully.
- Measure ingredients properly.
- Use proper pan placement.
- Place pans on the oven racks with 1" - 1 1/2" of air space on all sides of each pan. Avoid overcrowding the oven.
- Pans too close to each other, to oven walls or to the oven bottom, block the free movement of air. Improper air movement causes uneven browning and cooking.



2 cake layers

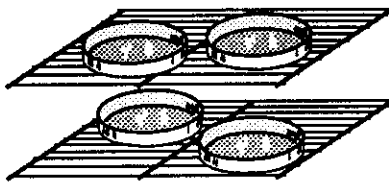

4 cake layers

- When baking several items stagger pans so that no pan is directly above another.
- Always turn oven to OFF before removing food.
- During baking, avoid frequent door openings. Keep oven door open as short a time as possible.
- Let the oven preheat thoroughly before cooking baked products. Watch the oven indicator light and put the food in the oven promptly after the light goes out.



**Never let food such as dairy products, fish, meat, poultry, etc., set for more than 1 hour before cooking starts when you set your oven for a delay start. Room temperature promotes the growth of harmful bacteria. Be sure the oven light is off because heat from the bulb will speed bacteria growth.**

- **Do not lock the oven door during baking.** The lock/unlock handle is used for self-cleaning only.
- Avoid opening the door too often to check the food during baking as heat will be lost. This may cause poor baking results.
- Cakes, cookies, muffins, and quick breads should be baked in shiny pans — to reflect the heat — because they should have a light golden crust. Yeast breads and pie crusts should be baked in glass or dull (non-shiny) pans — to absorb the heat — because they should have a brown, crisp crust.
- Be sure the underside of the pan is shiny too. Darkened undersides will absorb the heat and may cause over-browning on the bottom of your food.

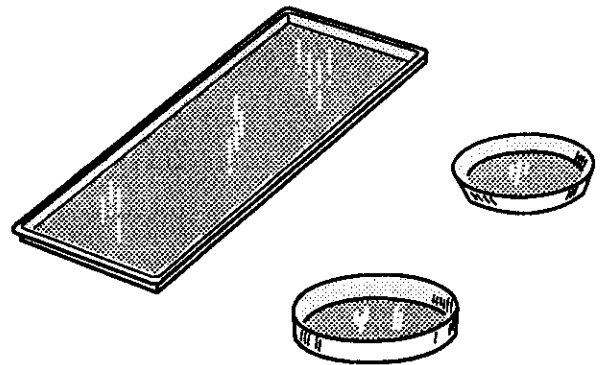

- Oven temperatures should be reduced 25 degrees below recommended temperatures if exterior of pan is predarkened, darkened by age or oven proof glass.
- There may be some odor when the oven is first used. This is caused by the heating of new parts and insulation.
- Do not cover an entire oven rack with foil. The foil can block normal heat flow and cause poor baking results. Do not place any foil directly above the bake element. Foil used on the oven bottom under the element may damage the oven surface; therefore, it should not be used.
- Cookies should be baked on flat cookie sheets without sides to allow the air to circulate properly.
- When recipes require preheating, have food nearby before you open the oven door. If the oven door is allowed to remain open for more than a brief time, the preheat temperature will be lost.
- Use residual heat in oven whenever possible to finish cooking casseroles, oven meals, etc. Use residual heat when warming rolls or precooked desserts.

# BROILING

- **Do not lock oven door during broiling.** The lock/unlock handle is used for self-cleaning only.
- Broiling is cooking by direct heat from the broil burner. Tender cuts of meat or marinated meat should be selected for broiling. For best results steaks and chops should be at least 3/4" thick.
- After placing food on the broiler pan, put the pan on the rack in the lower oven. The recommended rack position and cooking time can be found in the chart at right.
- The closer the food is to the broil burner, the faster the meat browns on the outside, yet stays red to pink in the center. Moving the meat farther away from the burner lets the meat cook to the center while browning outside. Side one should be cooked 1 - 2 minutes longer than side two.



**Your oven door should be open to the broil stop position while broiling. If the door is closed the food will roast and not broil.**

- Use only the broiler pan and grid that came with your range for broiling. They are designed for proper drainage of fat and liquids and help prevent spatter, smoke or fire.
- **Do not preheat when broiling.** Preheating may cause the thermostat to cycle the broil burner off and on. For even broiling on both sides, start the food on a cold pan.
- Trim the outer layer of fat from steaks and chops. Slit the fatty edges to keep the meat from curling.
- For maximum juiciness, salt the first side just before turning the meat. Salt the second side just before serving.
- Brush chicken and fish with butter several times as they broil. When broiling fish, grease the grid to prevent sticking and broil with skin side down. It is not necessary to turn fish.
- **Never leave a soiled broiler pan in the range.** Grease in the pan may smoke or burn the next time the oven is used.
- **Be sure you know the correct procedure for putting out a grease fire. See the section on safety.**



**Do not cover the entire broiler grid with foil. Poor drainage of hot fat may cause a broiler fire.**

**If a fire starts, close the oven door and turn controls off. If fire continues, throw baking soda on the fire. Do not put water on the fire.**

## POSITIONING BROILER PAN

Food	Rack Position 4 = Highest 1 = Lowest	Total Time (minutes)
<b>Steak – 1" Thick</b>		
Rare	4	9-11
Medium	3	13-15
Well Done	3	21-23
<b>Ground Beef Patties</b>		
Medium - 1" Thick	3	16-18
Medium - 1/2" Thick	4	7-9
<b>Lamb Chops – 1" Thick</b>	3	18-21
<b>Pork Chops – 1" Thick</b>	3	27-29
<b>Pork Chops - 1/2" Thick</b>	3	16-18
<b>Ham Slice – 1/2" Thick</b>	3	11-12
<b>Fish (Filets)</b>	3	11-13
<b>Chicken (Pieces)</b>	2	45-55
<b>Frankfurters</b>	3	8-11
<b>Bacon</b>	3	9-11

This chart is a general guide. The size, weight, thickness, and starting temperature of the food, as well as your own personal preference, will affect the cooking time. Times in the chart are based on the food being at refrigerator temperature.



# THE SELF-CLEAN CYCLE

## BEFORE A CLEAN CYCLE

1. Remove the broil pan and grid, oven racks, all utensils and any foil that may be in the oven. Do not try to clean utensils or any other objects in the oven during a self-clean cycle. If oven racks are left in the range during a clean cycle, they will darken, lose their luster and become hard to slide. If you choose to leave the racks in the oven, you can polish the edges of the racks with steel wool and apply a small amount of vegetable oil to the rack edges after the self-clean cycle. This will make the racks easier to slide.
2. Soil on the oven front frame, under the front edge of the cooktop, the door liner outside the door seal and the front edge of the oven cavity (about 1" into the oven) will not be cleaned during a clean cycle (see illustration below). Clean these areas by hand before starting a clean cycle.

Use hot water with a soap-filled steel wool pad, then rinse well.

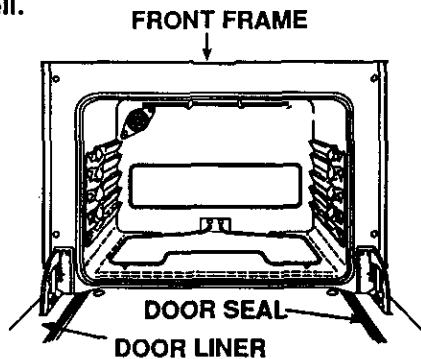

3. Wipe up heavy spillovers on the oven bottom. Too much soil may cause smoking during the clean cycle.
4. Clean the door seal by using a clean sponge to soak the soiled area with hydrogen peroxide. Repeated soaking may be needed depending on the amount of soil. Frequent cleaning will help prevent excessive soil buildup. Do not rub the door seal. The fiberglass material of the seal has an extremely low resistance to abrasion. An intact and well fitting oven door seal is essential for energy efficient oven operation and good baking results. If you notice the seal becoming worn, frayed or damaged in any way or if it has become displaced on the door, you should replace the seal.



**For your safety, the oven door cannot be unlocked while the oven is at cleaning temperature. After a clean cycle, the door cannot be unlocked until the temperature has dropped to a safe level (about 30 minutes).**

## TO SET A CLEAN CYCLE:

Recommended Cleaning Times:

Light Soil .....	1-1/2 hours
Moderate Soil .....	2-1/2 hours
Heavy Soil .....	3-1/2 hours

1. Set DELAY START TIME KNOB on the clock to the present time of day.
2. Set the STOP TIME knob to the time of day when you want the clean cycle to end.  
**Note: The oven will not unlock until the temperature has dropped to a safe level; about 30 minutes after the stop time.**
3. Turn OVEN SET KNOB to CLEAN.
4. Turn OVEN TEMP KNOB counterclockwise to CLEAN. Turn the knob all the way until it stops.
5. Slide the door lock/unlock handle all the way to the right to lock the door. You may need to press on the door slightly to get it to lock.

OVEN ● TEMP

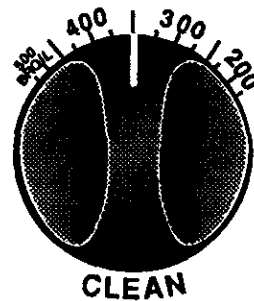

OVEN SET

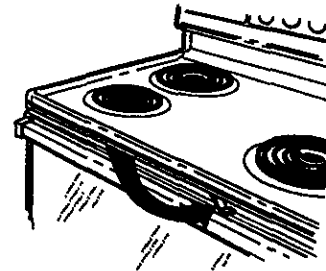
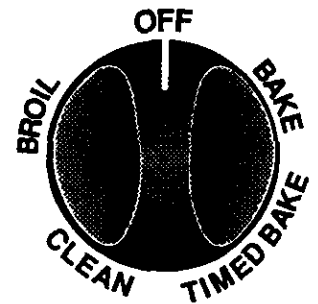

SLIDE DOOR LOCK/UNLOCK HANDLE TO THE RIGHT TO LOCK DOOR

## TO INTERRUPT A CLEAN CYCLE:

1. Turn STOP TIME knob to the current time of day.
2. Wait about 30 minutes.  
Do not force the door lock handle. Slide door lock/unlock handle to left to unlock door.
3. Turn OVEN SET KNOB to OFF.

## WHEN A CLEAN CYCLE IS FINISHED:

1. Stop time will be the same as the time of day.
2. Wait about 30 minutes. Do not force the door lock handle. Slide door/unlock handle to left to unlock door.
3. Turn OVEN SET KNOB to OFF. Turn OVEN TEMP KNOB clockwise.

## AFTER A CLEAN CYCLE

After a clean cycle, you may notice some white ash in the oven. Just wipe it up with a damp cloth.

If white spots remain, scrub them with a soap-filled steel wool pad. Be sure to rinse thoroughly with a white vinegar and water mixture. These deposits are usually a salt residue that cannot be removed by the clean cycle.

If the oven is not clean after one clean cycle, the cycle may be repeated.

## TO SET DELAYED CLEAN CYCLE:

NOTE: Clock must be set to correct time of day.

1. Turn OVEN SET KNOB to CLEAN.
2. Set the Delay Start Time Knob on the clock to the time of day when you want cleaning to begin.
3. Set the Stop Time Knob to the time of day when you want the clean cycle to end. (See recommended cleaning times on previous page.)

4. Turn OVEN TEMP KNOB to CLEAN. Turn the knob all the way until it stops.
5. Slide the door lock/unlock handle all the way to the right to lock the door.

After cleaning ends, wait about 30 minutes for oven to cool. Turn OVEN SET KNOB and OVEN TEMP KNOB to OFF. Slide door lock/unlock handle to left to unlock door. Never force the door lock handle.

## CLEANING TIPS

On the following pages, all removable parts on your range are shown. Refer to those pages when cleaning your range.

Warm water, a mild detergent and a soft cloth are safe to use on all cleanable parts of your range.

Do not use metal scouring pads, except where recommended.

PART	CLEANING MATERIALS	REMARKS
Control panel and knobs	Detergent, warm water, soft cloth	Do not use abrasive cleaners. Knobs pull off for easier cleaning.
Porcelain enameled cooktop	Detergent, warm water, plastic or nylon scouring pad	Clean after each spillover.
Self-cleaning oven finish	Detergent, warm water and/or soap-filled steel wool pad <b>Do not use oven cleaner in or around any part of the oven</b>	Rinse well after cleaning. Cleaning inside the oven need only be done as an optional touch-up between self-clean cycles. See the self-cleaning section for more information.
Oven door gasket	Hydrogen peroxide	Soak with hydrogen peroxide, using a sponge. Frequent soaking helps prevent soil buildup. Do not rub. See self-clean section for more information.
Oven racks	Detergent, warm water, soap-filled scouring pad, plastic scouring pad	Remove from oven to clean. Rinse thoroughly.
Burner box bottom (area under cooktop)	Detergent and water	Clean after each spillover with detergent and water. Dry well.
Broiler pan and grid	Detergent, warm water, soap-filled scouring pad, commercial oven cleaner (pan only)	Remove soiled pan from oven to cool. Drain fat or drippings. Fill pan with warm water. Sprinkle grid with detergent and cover with damp cloth or paper towels. Let pan and grid soak for a few minutes. Rinse or scour as needed. Dry well. Grid and pan may be washed in a dishwasher.
Glass	Glass cleaner and paper towels	Remove stubborn soil with paste of baking soda and water. DO NOT use abrasive cleaners. Rinse thoroughly.
Painted Oven Door Panel (Outer edges and front of door; [Model 93121])	Mild detergent, water, glass cleaner, paper towels	Do not clean with abrasives. Do not use mild or harsh abrasives. Do not use scouring pads.

# CLEANING TIPS (cont.)

PART	CLEANING MATERIALS	REMARKS
Chrome drip bowls		<b>Bowls can permanently discolor if exposed to excessive heat or if soil is allowed to bake on.</b>
Brown food stains	Detergent and water, plastic scouring pads, mild abrasive cleaners, soap-filled scouring pads, ammonia	After each use, wash, rinse and dry to prevent difficult soils. If heavily soiled, place an ammonia-soaked paper towel on stains to loosen soil, then gently scrub with plastic scouring pad.
Blue/gold heat stains	Metal Polish	These stains are caused by overheating, normally occur over a period of time, and usually are permanent. To minimize: <ol style="list-style-type: none"> <li>1. Avoid excessive use of the high heat setting. Use it to start cooking, then lower the heat setting to finish cooking.</li> <li>2. Use flat bottom pans that do not extend more than two inches from the surface element.</li> </ol>

## REMOVABLE KNOBS

The control knobs may be removed for easy cleaning by pulling the knob straight off stem. Be sure that the knob is in the OFF position before removal.

Hint: Slip a thin cloth (such as a handkerchief) or a piece of string under and around the knob edge and pull up.

**Caution: Read these instructions carefully before replacing the knobs. Replacing the knobs improperly will damage the knobs and the spring clip on the stems. If this happens, the knobs will fit loosely.**

**To replace the knob:**

1. The knob stem has a groove in each side. The groove on one side has a spring clip. The other groove is clear (see illustration).

2. Check the inside of the knob and find the molded rib.
3. Replace the knob by fitting the molded rib inside the knob into the clear groove on the stem.

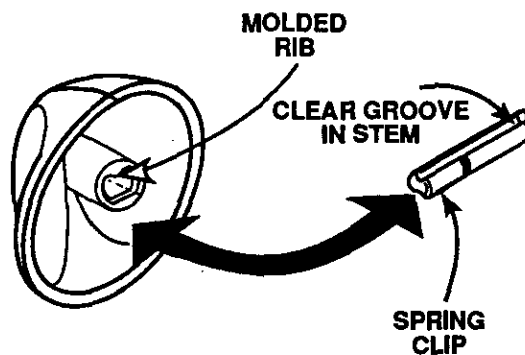

## REMOVABLE COOKTOP UNITS

The cooktop elements can be unplugged and the bowls removed for cleaning.

**Be sure all cooktop unit control knobs are turned off and elements are cool before you remove or replace a cooktop unit.**

**To remove:**

1. Grasp element, tilt it upward slightly to clear the bowl, then pull away from the receptacle. The element will not sit level when replaced if it is forced too far upward when removed.
2. See the Cleaning Tips Section about information on cleaning reflector bowls.
3. Lift out the bowl.

Do not put the element into water. It cleans itself when heated during normal use.

**IMPORTANT: Never operate a cooktop element without the bowl in place. This can cause scorching of the cooktop, burning of wiring insulation and loss of energy.**

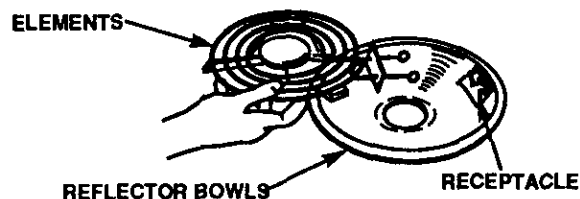

**To replace:**

1. Replace the bowl. Be sure the receptacle is showing in the bowl opening.
2. Slide the plug of the element firmly into the receptacle and lower the element into place.

## ANTI-TIP DEVICE



If your range is removed for cleaning, servicing or any reason, be sure anti-tip device is re-engaged properly when the range is replaced. Failure to take this precaution could result in tipping of the range and cause injury.

When replacing the range:

1. Slide the range into place.
2. Be sure the rear leg leveler fully engages the slot in the bracket. To insure the device is properly installed and engaged, remove the drawer panel and inspect the rear leveling leg. Make sure it fits securely into the slot.

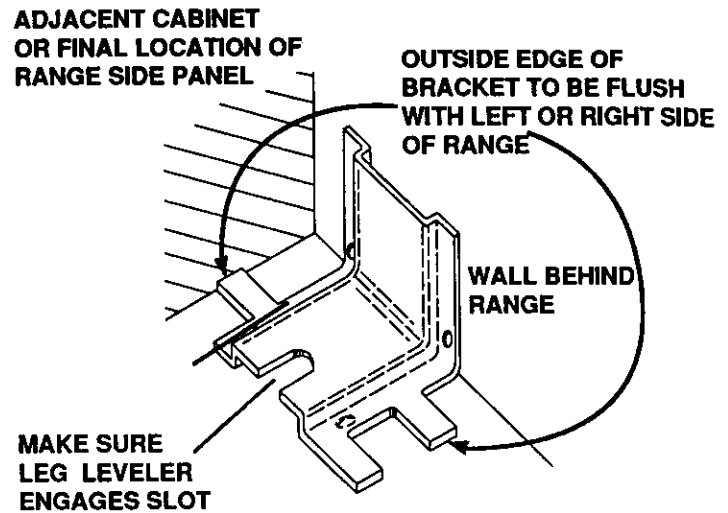

## REMOVABLE STORAGE DRAWER

This drawer gives you space for keeping cookware and bakeware. Plastics and flammable material should not be kept in this drawer.

Do not overload the storage drawer. If the drawer is too heavy, it may slip off the track when opened. To open the drawer, grasp the center of the handle and pull straight out.

**To remove:** Pull drawer straight out and lift over the guide stops.

**To replace:** Lift over the guide stops and slide drawer into place.

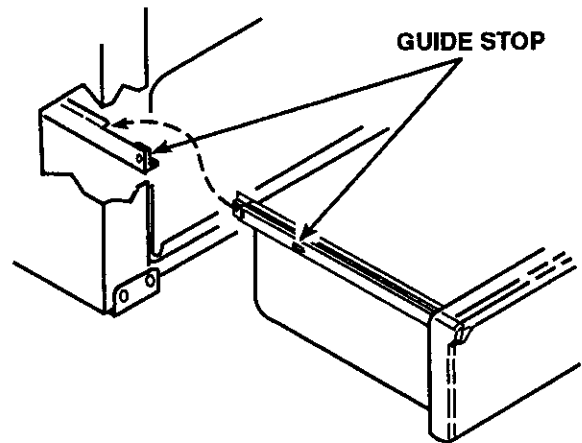

## REPLACING THE OVEN LIGHT

Be sure that the light switch is in the off position.

Do not touch hot oven bulb. Do not touch oven bulb with wet hands. Do not wipe oven light area with wet cloth.

Never touch the electrically live collar on the bulb when replacing it.

Electrical power must be shut off if you have to replace a broken bulb.

1. Unscrew glass cover and remove.
2. Replace the bulb with a 40 watt appliance bulb.
3. Replace the cover.

**Note:** We recommend you use a 40 watt appliance bulb that is no longer than 3 1/2".

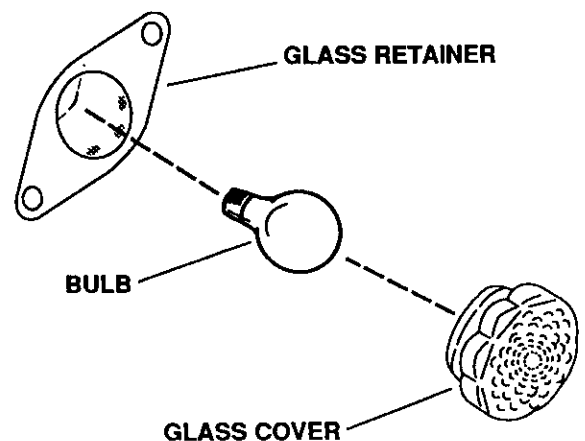

## REMOVABLE OVEN RACKS

Be careful not to scratch the oven finish when installing or removing oven racks.

### To install:

1. Set the raised back edge of the rack on a pair of rack guides.
2. Push the rack in until you reach the bump in the rack guide, then lift the front of the rack and push the rack all the way in.

### To remove:

1. Pull the oven rack out, then up.

Some models have one standard oven rack and one folding oven rack.

The folding rack can be easily stored away when not in use.

**NOTE:** For best performance remove oven racks during a clean cycle. If oven racks are left in the range during a self-clean cycle, they will darken, lose their luster and become hard to slide.

If you choose to leave the racks in the oven, you can polish the edges of the racks with steel wool and apply a small amount of vegetable oil to the rack edges after the self-clean cycle.

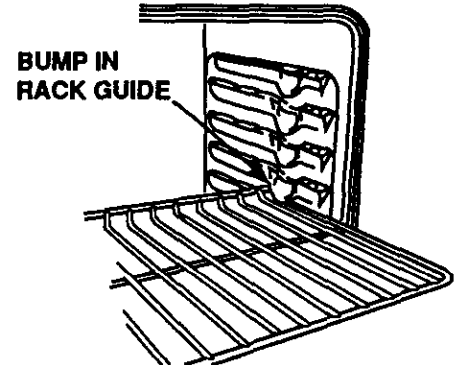

## REMOVABLE OVEN DOOR

### To remove:

1. Open the door to the stop position (see illustration).
2. Grasp the door at each side and lift up and off the hinges.

**NOTE:** When the door is removed and hinge arms are at stop position, do not bump or try to move the hinge arms. The hinges could snap back causing an injury to the hands or damage to the porcelain on the front of the range. Cover the hinges with toweling or empty towel rolls while working in the oven area.

### To replace:

1. Hold the door over the hinges with the slots at the bottom edge of the door lined up with the hinges. The hinge arms must still be in the stop position.
2. Slide the door down onto the hinges as far as it will go and close the door.

STOP (BROIL) POSITION

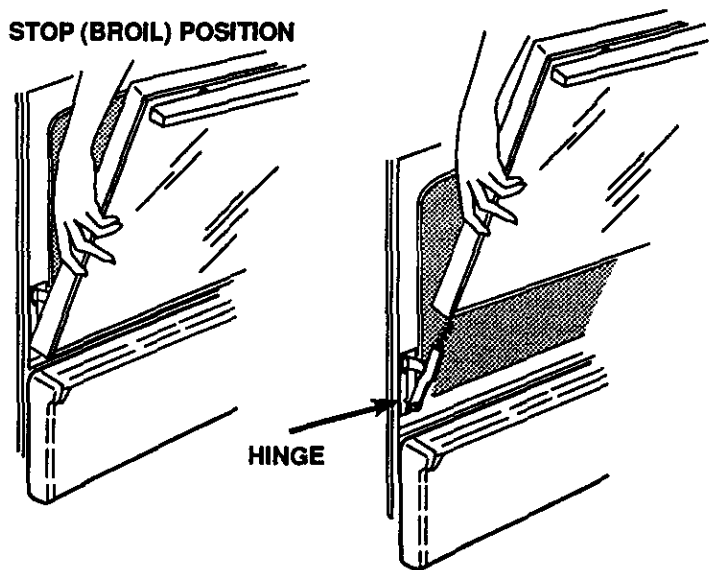

## LIFT-UP COOKTOP

The cooktop can be raised so the area underneath can be cleaned.

### To raise cooktop:

1. Remove the cooktop units.
2. Grasp the front of the cooktop and lift up until the support rods snap into position to hold the cooktop. Porcelain enamel can chip. Handle porcelain enameled cooktops carefully.

### To lower cooktop:

1. Push in on the front of the support rods while lowering the cooktop.

**NOTE:** Some models do not have prop rods.

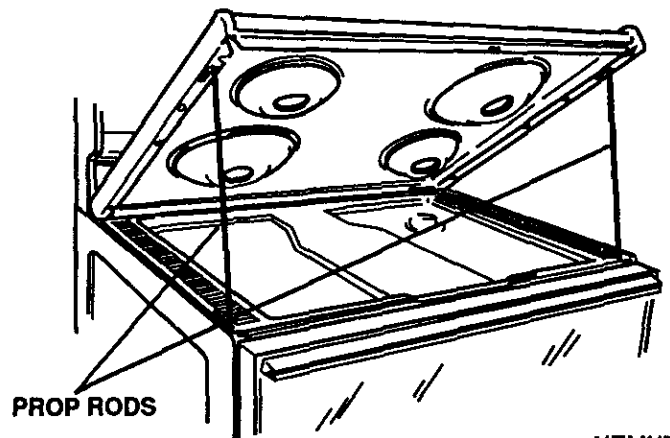

# BEFORE CALLING FOR SERVICE

**Save time and money — Check this list before you call for service.**

To eliminate unnecessary service calls, first, read all the instructions in this manual carefully. Then, if you have a problem, always check this list of common problems and possible solutions before you call for service.

If you do have a problem you cannot fix yourself, call your nearest Sears Store or Service Center for help. When calling, have this manual, the Repair Parts List, your model number, serial number and purchase date handy.

<b>PROBLEM</b>	<b>POSSIBLE CAUSE</b>	<b>DON'T CALL FOR SERVICE UNTIL YOU CHECK</b>
<ul style="list-style-type: none"> <li>• Range does not work; totally inoperative</li> </ul>	<ul style="list-style-type: none"> <li>• No power to range</li> </ul>	<ul style="list-style-type: none"> <li>• Check household circuit breaker or fuse.</li> <li>• Check cord (if equipped) to be sure it is plugged in.</li> </ul>
<ul style="list-style-type: none"> <li>• Oven does not heat; cooktop elements OK</li> </ul>	<ul style="list-style-type: none"> <li>• Oven controls set incorrectly</li> <li>• Oven Temp Knob turned too far past 500 Broil</li> </ul>	<ul style="list-style-type: none"> <li>• Check oven control.</li> <li>• 500 Broil must be aligned with Indicator mark above Oven Temp Knob.</li> </ul>
<ul style="list-style-type: none"> <li>• Cooktop does not work; oven OK</li> </ul>	<ul style="list-style-type: none"> <li>• Element(s) unplugged</li> <li>• Improper operation of control</li> </ul>	<ul style="list-style-type: none"> <li>• Check element connections by removing and re-plugging element(s) firmly.</li> <li>• Be sure knob is pushed in while turning.</li> </ul>
<ul style="list-style-type: none"> <li>• Foods do not bake properly</li> </ul>	<ul style="list-style-type: none"> <li>• Oven not preheated long enough</li> <li>• Improper rack or pan placement</li> <li>• Oven vent blocked or covered</li> <li>• Improper use of foil</li> <li>• Improper temperature setting for utensil used</li> <li>• Recipe not followed</li> <li>• Range and oven rack not level</li> <li>• Using improper cookware</li> </ul>	<ul style="list-style-type: none"> <li>• Be sure to preheat until Oven Temp Indicator Light goes out.</li> <li>• Maintain uniform air space around pans and utensils; see cooking hints section.</li> <li>• Reflector bowl for right rear element <b>must</b> have hole in the center over the oven vent.</li> <li>• Foil use <b>not</b> recommended.</li> <li>• Reduce temperature 25° for glass or dull/darkened pans.</li> <li>• Is recipe tested and reliable?</li> <li>• Check the installation section for leveling instructions.</li> <li>• See cooking hints.</li> </ul>
<ul style="list-style-type: none"> <li>• Oven temperature seems inaccurate</li> </ul>	<ul style="list-style-type: none"> <li>• Thermostat calibration</li> </ul>	<ul style="list-style-type: none"> <li>• See adjustments described in THERMOSTAT ADJUSTMENTS section.</li> </ul>
<ul style="list-style-type: none"> <li>• Foods do not broil properly</li> </ul>	<ul style="list-style-type: none"> <li>• Oven door closed</li> <li>• Improper rack position</li> <li>• Oven preheated</li> <li>• Improper utensil used</li> <li>• Improper broiling time</li> </ul>	<ul style="list-style-type: none"> <li>• Open door to broil stop position.</li> <li>• Check broil pan placement; see Broiling section.</li> <li>• Do not preheat when broiling.</li> <li>• Use broiler pan and grid supplied with range.</li> <li>• Check broiling chart.</li> </ul>
<ul style="list-style-type: none"> <li>• Oven smokes</li> </ul>	<ul style="list-style-type: none"> <li>• Dirty oven</li> <li>• Broiler pan full of grease left in oven</li> </ul>	<ul style="list-style-type: none"> <li>• Check for heavy spillover.</li> <li>• Check pan and grid after each use.</li> </ul>

## BEFORE CALLING FOR SERVICE (continued)

PROBLEM	POSSIBLE CAUSE	DON'T CALL FOR SERVICE UNTIL YOU CHECK
<ul style="list-style-type: none"> <li>Oven will not self-clean or poor self-cleaning results</li> </ul>	<ul style="list-style-type: none"> <li>Controls set incorrectly</li> <li>Clean cycle interrupted too soon</li> <li>Oven too dirty</li> </ul>	<ul style="list-style-type: none"> <li>See self-clean instructions.</li> <li>Heavily soiled ovens require a 3 1/2 hour clean cycle.</li> <li>Heavy spillovers should be removed before setting clean cycle. Repeat clean cycle.</li> </ul>
<ul style="list-style-type: none"> <li>Oven door will not unlock</li> </ul>	<ul style="list-style-type: none"> <li>Clean cycle not complete</li> <li>Door accidentally locked while baking or broiling</li> </ul>	<ul style="list-style-type: none"> <li>Oven must cool below lock temperature (approximately 30 minutes after clean cycle is complete).</li> <li>Turn oven control to OFF. Wait until oven cools and door will unlock. Do not force the door lock.</li> </ul>
<ul style="list-style-type: none"> <li>Oven light does not work</li> </ul>	<ul style="list-style-type: none"> <li>Light switch in OFF position</li> <li>Light bulb burned out</li> </ul>	<ul style="list-style-type: none"> <li>Check switch setting; see operating instructions.</li> <li>Check or replace light bulb; see removable parts section of this manual.</li> </ul>

## THERMOSTAT ADJUSTMENTS

The temperature in your new oven has been set correctly at the factory, so be sure to follow the recipe temperatures and times the first few times you bake in your new oven.

If you think the oven should be hotter or cooler, you can adjust it yourself. To decide how much to change the temperature, set the oven temperature 25°F higher or lower than the temperature in your recipe, then bake. The results of this "test" should give you an idea of how much the temperature should be changed.

### To adjust knob:

- Turn OVEN SET KNOB to OFF and remove the knob by pulling straight off.
- Look at the back of the knob. The arrow pointing to the center of the bottom screw indicates the original factory setting.
- Use a screwdriver to loosen the two screws about 2 turns each.

- Hold the knob handle (A on illustration) while turning the disk (B on illustration) in the desired direction to increase or decrease the temperature. (See illustration below for "Self-Clean Thermostat".) As you turn, you should be able to hear clicks and feel notches or teeth. Each click or notch is 15°F. You can turn up to 2 clicks or notches in either direction.
- When you reach the desired adjustment, retighten both screws.

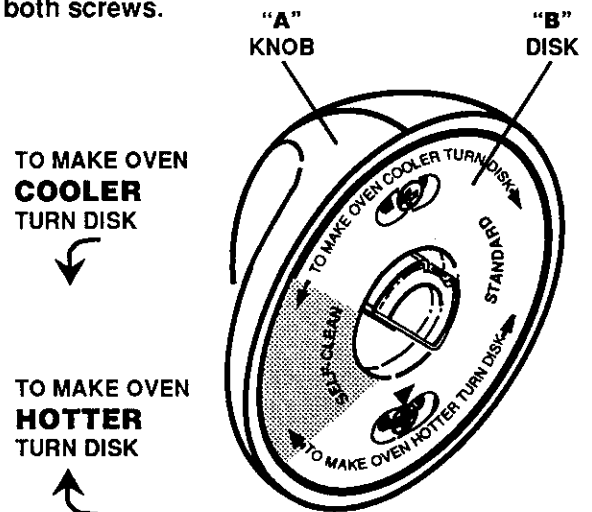

# KENMORE ELECTRIC RANGE WARRANTY

Dear Customer:

Our constant efforts are directed toward making sure your new Kenmore Range will arrive at your home in perfect condition and will give you proper performance. As part of these efforts, we feel it is our responsibility to provide you with this warranty for your range.

## FULL ONE YEAR WARRANTY ON THE FUNCTIONING OF ALL PARTS EXCEPT GLASS PARTS

If, within one year from the date of installation, any part, other than a glass part, fails to function properly due to a defect in material or workmanship, Sears will repair or replace it, free of charge.

## FULL 30-DAY WARRANTY ON GLASS PARTS AND FINISH OF PORCELAIN ENAMEL, PAINTED OR BRIGHT METAL FINISHED PARTS

If, within 30 days from the date of installation, any glass part or the finish on any porcelain enamel, painted or bright metal part is defective in material or workmanship, Sears will replace the part, free of charge.

## FULL 90-DAY WARRANTY ON MECHANICAL ADJUSTMENTS

For 90 days from the date of installation, Sears will provide, free of charge, any mechanical adjustments necessary for proper operation of the range, except for normal maintenance.

If the range is subjected to other than private family use, the above warranty coverage is effective for only 90 days.

## WARRANTY SERVICE IS AVAILABLE BY CONTACTING THE NEAREST SEARS SERVICE CENTER/DEPARTMENT IN THE UNITED STATES

This warranty applies only while this product is in use in the United States. This warranty gives you specific legal rights, and you may also have other rights which vary from state to state.

**SEARS, ROEBUCK and CO.**  
 Dept. 731 CR-W  
 Sears Tower  
 Chicago, IL 60684

## WE SERVICE WHAT WE SELL

"We Service What We Sell" is our assurance to you that you can depend on Sears for service because Sears service is nationwide.

Your Kenmore Range has added value when you consider that Sears has a service unit near you staffed by Sears trained technicians. . . professional technicians specifically trained on Sears appliances, having the parts, tools and equipment to ensure that we meet our pledge to you — "We Service What We Sell!"

**TO FURTHER ADD TO THE VALUE OF YOUR RANGE, BUY A SEARS MAINTENANCE AGREEMENT.**

Kenmore Ranges are designed, manufactured and tested for years of dependable operation. Yet, any modern appliance may require service from time to time. The Sears warranty plus the Sears Maintenance Agreement provides protection from unexpected repair bills and assures you of enjoying maximum range efficiency.

Here's a comparative warranty and Maintenance Agreement chart showing you the benefits of a Sears Range Maintenance Agreement.

Years of Ownership Coverage		1st Year	2nd Year	3rd Year
1	Replacement of Defective Parts other than Porcelain or Glass	W	MA	MA
2	Mechanical Adjustment	90 DAYS W	MA	MA
3	Porcelain and Glass Parts	30 DAYS W	MA	MA
4	Annual Preventive Maintenance Check at your request	MA	MA	MA

W - Warranty MA - Maintenance Agreement

**CONTACT YOUR SEARS SALESPERSON OR LOCAL SEARS SERVICE CENTER TODAY AND PURCHASE A SEARS MAINTENANCE AGREEMENT.**

**Kenmore® America's Best Selling Appliance Brand**

Sold by SEARS, ROEBUCK AND CO., Chicago, IL 60684