

SEARS

CRAFTSMAN®

MODEL NUMBER 917.373980

OWNER'S MANUAL

3one™
Convertible

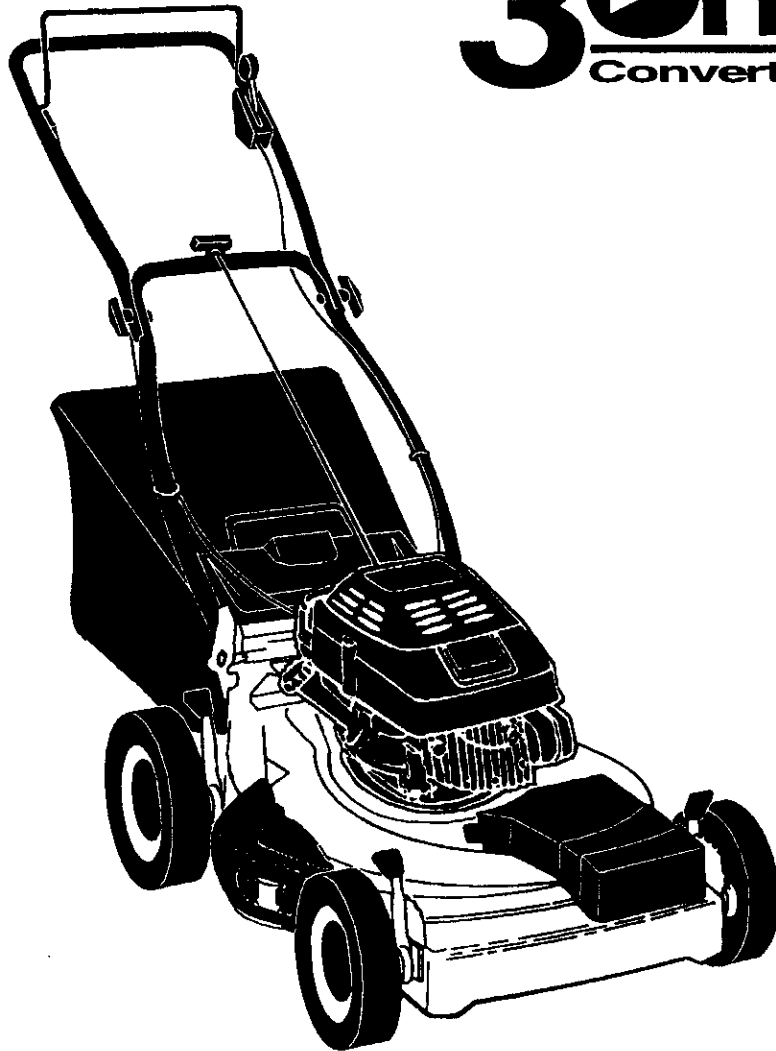

- **Assembly**
- **Operation**
- **Customer Responsibilities**
- **Service**
- **Adjustments**
- **Repair Parts**

Caution:
Read and Follow
all Safety Rules
and Instructions
Before Operating
This Equipment

Sears, Roebuck and Co., Hoffman Estates, IL 60179 U.S.A.

SAFETY RULES



CAUTION: ALWAYS DISCONNECT SPARK PLUG WIRE AND PLACE WIRE WHERE IT CANNOT CONTACT SPARK PLUG TO PREVENT ACCIDENTAL STARTING WHEN SETTING UP, TRANSPORTING, ADJUSTING OR MAKING REPAIRS.



IMPORTANT

SAFETY STANDARDS REQUIRE OPERATOR PRESENCE CONTROLS TO MINIMIZE THE RISK OF INJURY. YOUR UNIT IS EQUIPPED WITH SUCH CONTROLS. DO NOT ATTEMPT TO DEFEAT THE FUNCTION OF THE OPERATOR PRESENCE CONTROLS UNDER ANY CIRCUMSTANCES.

TRAINING:

- Read this operator's manual carefully. Become familiar with the controls and know how to operate your mower properly. Learn how to quickly stop mower.
- Do not allow children to use your mower. Never allow adults to use mower without proper instructions.
- Keep the area of operation clear of all persons, especially small children and pets.
- Use mower only as the manufacturer intended and as described in this manual.
- Do not operate mower if it has been dropped or damaged in any manner. Always have damage repaired before using your mower.
- Do not use accessory attachments that are not recommended by the manufacturer. Use of such attachments may be hazardous.
- The blade turns when the engine is running.
- Always stop the engine whenever you leave or are not using your mower, or before crossing driveways, walks, roads, or any gravel-covered areas.
- Never direct discharge of material toward bystanders allow anyone near the mower while you are operating it
- Before cleaning, inspecting, or repairing your mower, stop the engine and make absolutely sure the blade and moving parts have stopped. Then disconnect the spark plug wire and keep it away from the spark plug to prevent accidental starting.
- Do not continue to run your mower if you hit a foreign object. Follow the procedure outlined above, then repair any damage before restarting and operating your mower.
- Do not change the governor settings or overspeed the engine. Engine damage or personal injury may result.
- Do not operate your mower if it vibrates abnormally. Excessive vibration is an indication of damage; stop the engine safely check for the cause of vibration and repair as required.
- Do not run the engine indoors. Exhaust fumes are dangerous.
- Never cut grass by pulling the mower towards you. Move across the face of slopes, never up and down or you may lose your footing. Do not mow excessively steep slopes. Use caution when operating the mower on uneven terrain when changing directions - maintain good footing.
- Never operate your mower without proper guards, plate grass catcher or other safety devices in place.

PREPARATION:

- Always thoroughly check the area to be mowed and clear it of all stones, sticks, wires, bones, and other foreign objects. These objects will be thrown by the blade and can cause severe injury.
- Always wear safety glasses or eye shields when starting and while using your mower.
- Dress properly. Do not operate mower when barefoot or wearing open sandals. Wear only solid shoes with good traction when mowing.
- Check fuel tank before starting engine. Do not fill gas tank indoors, when the engine is running or when the engine is hot. Allow the engine to cool for several minutes before filling the gas tank. Clean off any spilled gasoline before starting the engine.
- Always make wheel height adjustments before starting your mower. Never attempt to do this while the engine is running.
- Mow only in daylight or good artificial light.

OPERATION:

- Keep your eyes and mind on your mower and the area being cut. Do not let other interests distract you.
- Do not mow wet or slippery grass. Never run while operating your mower. Always be sure of your footing - keep a firm hold on the handles and walk.
- Do not put hands or feet near or under rotating parts. Keep clear of the discharge opening at all times.

MAINTENANCE AND STORAGE:

- Check the blade and the engine mounting bolts often to sure they are tightened properly.
- Check all bolts, nuts and screws at frequent intervals proper tightness to be sure mower is in safe working condition.
- Keep all safety devices in place and working.
- To reduce fire hazard, keep the engine free of grass, leaves or excessive grease and oil.
- Check grass catcher often for deterioration and wear and replace worn bags. Use only replacement bags that are recommended by and comply with specifications of the manufacturer of your mower.
- Always keep a sharp blade on your mower.
- Allow engine to cool before storing in any enclosure.
- Never store mower with fuel in the tank inside a building where fumes may reach an open flame or an ignition source such as a hot water heater, space heater, clothes dryer, etc.



LOOK FOR THIS SYMBOL TO POINT OUT IMPORTANT SAFETY PRECAUTIONS. IT MEANS - ATTENTION!!! BECOME ALERT!!! YOUR SAFETY IS INVOLVED.

CONGRATULATIONS on your purchase of a Sears Lawn Mower. It has been designed, engineered and manufactured to give you the best possible dependability and performance.

Should you experience any problem you cannot easily remedy, please contact your nearest Sears Authorized Service Center/Department. We have competent, well-trained technicians and the proper tools to service or repair this lawn mower.

Please read and retain this manual. The instructions will enable you to assemble and maintain your lawn mower properly. Always observe the "SAFETY RULES".

MODEL NUMBER	917.373980
SERIAL NUMBER	_____
DATE OF PURCHASE	_____
THE MODEL AND SERIAL NUMBERS WILL BE FOUND ON A DECAL ATTACHED TO THE REAR OF THE LAWN MOWER HOUSING	
YOU SHOULD RECORD BOTH SERIAL NUMBER AND DATE OF PURCHASE AND KEEP IN A SAFE PLACE FOR FUTURE REFERENCE.	

PRODUCT SPECIFICATIONS

HORSEPOWER:	5.5
DISPLACEMENT:	12.6 cu. in.
GASOLINE CAPACITY AND TYPE:	1.25 quart UNLEADED REGULAR
OIL TYPE (API-SG):	SAE 30 (above 32°F) SAE 5W-30 (below 32°F)
OIL CAPACITY:	20 oz.
SPARK PLUG: (GAP: .030")	CHAMPION RJ19LM STD361458
VALVE CLEARANCE:	INTAKE: .008" EXHAUST: .008"
SOLID STATE IGNITION AIR GAP:	.0125 in.
BLADE BOLT TORQUE:	35-40 FT. LBS.

MAINTENANCE AGREEMENT

A Sears Maintenance Agreement is available on this product. Contact your nearest Sears store for details.

CUSTOMER RESPONSIBILITIES

- Read and observe the safety rules.
- Follow a regular schedule in maintaining, caring for and using your lawn mower.
- Follow the instructions under "Customer Responsibilities" and "Storage" sections of this owner's manual.

LIMITED TWO YEAR WARRANTY ON CRAFTSMAN POWER MOWER

For two years from date of purchase, when this Craftsman Lawn Mower is maintained, lubricated, and tuned up according to the operating and maintenance instructions in the owner's manual, Sears will repair free of charge any defect in material or workmanship.

If this Craftsman Lawn Mower is used for commercial or rental purposes, this warranty applies for only 90 days from the date of purchase.

This Warranty does not cover:

- Expendable items which become worn during normal use, such as rotary mower blades, blade adapters, belts, air cleaners and spark plug.
- Repairs necessary because of operator abuse or negligence, including bent crankshafts and the failure to maintain the equipment according to the instructions contained in the owner's manual.

WARRANTY SERVICE IS AVAILABLE BY RETURNING THE CRAFTSMAN POWER MOWER TO THE NEAREST SEARS SERVICE CENTER/DEPARTMENT IN THE UNITED STATES. THIS WARRANTY APPLIES ONLY WHILE THIS PRODUCT IS IN USE IN THE UNITED STATES.

This Warranty gives you specific legal rights, and you may also have other rights which vary from state to state.

SEARS, ROEBUCK AND CO., D/817 WA, HOFFMAN ESTATES, ILLINOIS 60179

TABLE OF CONTENTS

SAFETY RULES	2	MAINTENANCE SCHEDULE	1
PRODUCT SPECIFICATIONS	3	SERVICE AND ADJUSTMENTS	1
CUSTOMER RESPONSIBILITIES	3, 12-14	STORAGE	1
WARRANTY	3	TROUBLESHOOTING	1
ASSEMBLY	6	REPAIR PARTS - LAWN MOWER	18-21
OPERATION	8	REPAIR PARTS - ENGINE	23-25
		PARTS ORDERING/SERVICE	BACK COVER





INDEX

A		E		Operation:	
Accessories	5	Engine:		Drive Control	9
Adjustments:		Air Filter	14	Engine Control	9
Carburetor	16	Oil Change	14	Grass Catcher	10
Engine Speed	16	Oil Level	14	Mower	9
Handle Height	16	Oil Type	14	Operator Presence Control Bar	9
Height of Cut	9	Starting	10	Options:	
Air Filter:		Stopping	10	Accessories	5
Replacement	14	Storage	17		
Service	14			R	
Assembly	6			Repair Parts:	
		F		Engine	23-25
		Fuel:		Lawn Mower	18-22
		Capacity	3	Responsibilities, Customer	3, 12-14
		Storage	17		
		Type	10	S	
				Safety Rules	2
		L		Service and Adjustments	15
		Lubrication:		Carburetor	16
		Engine	14	Engine Speed	16
		Lawn Mower	12	Handle	16
				Spark Plug	14
		M		Specifications	3
		Maintenance Agreement	3	Speed Control:	
		Maintenance Schedule	12	Engine	10
		Mowing Tips	11	Starting the Engine	10
				Stopping the Engine	10
		O		Storage	17
		Oil:			
		Engine	10	T	
		Storage	17	Troubleshooting Chart	27
				W	
				Warranty	3

LAWN MOWER ACCESSORIES

These accessories were available when this lawn mower was produced. They are also available at most Sears retail outlets and service centers. Most Sears stores can also order repair parts for you, when you provide the model number of your lawn mower. Some of these accessories may not apply to your lawn mower.

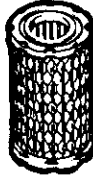
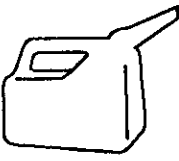
ENGINE

SPARK PLUG 	MUFFLER 	AIR FILTER 	GAS CAN 	ENGINE OIL 	STABILIZER 
--	---	--	--	--	--



If lawn mower is an electric start

CHARGER 	BATTERY 
--	---

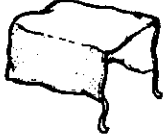
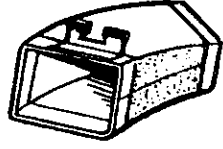
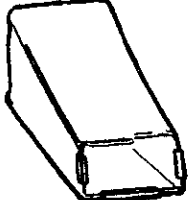
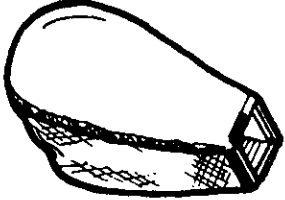
LAWN MOWER PERFORMANCE

REAR BAG OPTIONAL	DUST SHIELD 	CLIPPING DEFLECTOR 	
REPLACEMENT BAG FOR REAR DISCHARGE LAWN MOWERS	FABRIC BAG 	OPTIONAL CATCHER FOR SIDE DISCHARGE LAWN MOWER	SIDE DISCHARGE CATCHER 

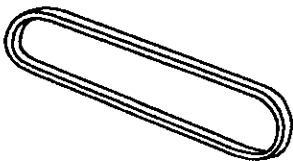
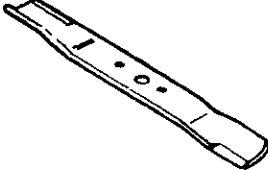
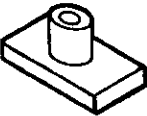
LAWN MOWER MAINTENANCE

BELT 	BLADE 	BLADE ADAPTER 	WHEELS 	LAWN MOWER COVER 
--	---	---	--	--

ASSEMBLY

Read these instructions and this manual in its entirety before you attempt to assemble or operate your new lawn mower. Your new lawn mower has been assembled at the factory with the exception of those parts left unassembled for shipping purposes. To ensure safe and proper operation of your lawn mower, all parts and hardware you assemble must be tightened securely. Use the correct tools as necessary to ensure proper tightness. All parts such as nuts, washers, bolts, etc., necessary to complete the assembly have been placed in the parts bag.

TO REMOVE LAWN MOWER FROM CARTON

- Remove loose parts included with mower.
- Cut down two end corners of carton and lay end panel down flat.
- Remove all packing materials except padding between upper and lower handle and padding holding operator presence control bar to upper handle.
- Roll lawn mower out of carton and check carton thoroughly for additional loose parts.

HOW TO SET UP YOUR LAWN MOWER TO UNFOLD HANDLE (See Fig. 1)

IMPORTANT: UNFOLD HANDLE CAREFULLY SO AS NOT TO PINCH OR DAMAGE CONTROL CABLES.

- Raise handles until lower handle section locks into place in mowing position.
- Raise upper handle section into place on lower handle, remove protective padding and tighten both handle knobs.
- Remove handle padding holding operator presence control bar to upper handle.
- Your lawn mower handle can be adjusted for your mowing comfort. Refer to "Adjust Handle" in the Service and Adjustment section of this manual.

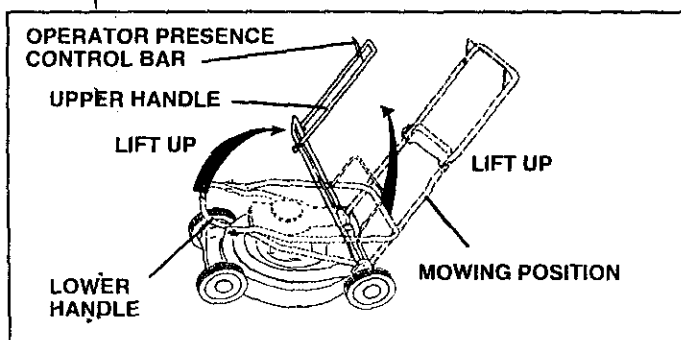

FIG. 1

TO CONVERT MOWER

Your lawn mower was shipped ready to be used as a mulcher. To convert to bagging or discharging:

REAR BAGGING (See Fig. 2A) -

- Open rear door and remove mulcher plate. Store mulcher plate in a safe place.
- You can now install grass catcher.
- To convert to mulching or discharging operation, install mulcher plate into rear discharge opening of mower, making sure all tabs are seated properly.

SIDE DISCHARGING (See Fig. 2B) -

- Mulcher plate must be installed into rear discharge opening of mower (see above instructions).
- Unlock closed discharge guard by lifting latch and allow guard to swing open to discharging position.
- Mower is now ready for discharging operation.
- To convert to mulching or bagging operation, discharge guard must be closed and locked securely.

SIMPLE STEPS TO REMEMBER

WHEN CONVERTING YOUR LAWN MOWER

FOR MULCHING -

- Rear mulcher plate installed.
- Side discharge guard closed and locked securely.

FOR REAR BAGGING -

- Rear mulcher plate removed.
- Grass catcher installed.
- Side discharge guard closed and locked securely.

FOR SIDE DISCHARGING -

- Rear mulcher plate installed.
- Side discharge guard unlocked and open.



CAUTION: Do not run your lawn mower without rear mulcher plate in place or approved grass catcher in place. Never attempt to operate the lawn mower with the rear door removed or propped open.

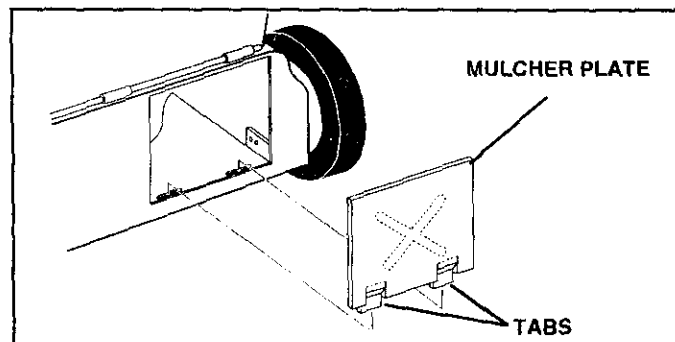

FIG. 2A

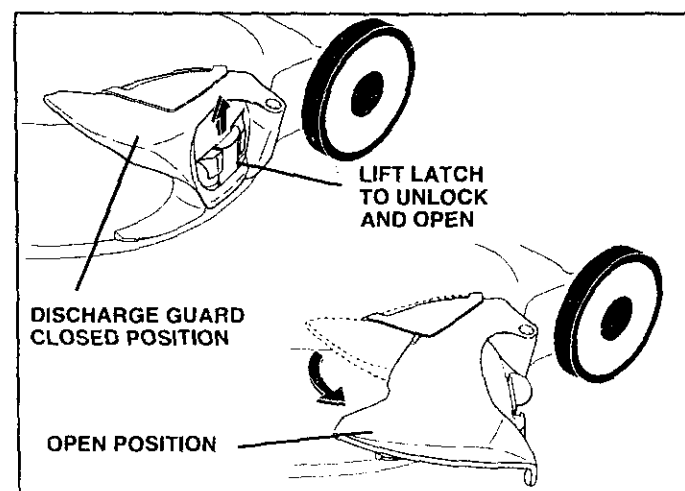

FIG. 2B

ASSEMBLY

TO ASSEMBLE AND ATTACH GRASS CATCHER (See Figs. 3A thru 4)

- To assemble tubular frame to grass bag, work sewn hem of bag out through the front opening of bag to expose the hem.
- Thread tubular frame into hem and gather material at top of frame as shown.
- Push frame inside bag through the opening until only the ends of frame are exposed out of the front.

NOTE: Do not close the flip lid at this time.

- Assemble lower frame to tubular frame as shown. Be sure frames are fully seated together as shown in inset.
- Slip vinyl bindings over frame.

NOTE: If vinyl bindings are too stiff, hold them in warm water for a few minutes. If bag gets wet, let it dry before using.

- Close the flip lid. Flip lid must be closed while operating lawn mower.
- Lift the rear door on the mower housing and place the grass catcher frame onto the formed tabs on the rear door hinge bracket.
- The grass catcher is secured to the lawn mower housing when the rear door is lowered onto the grass catcher frame.

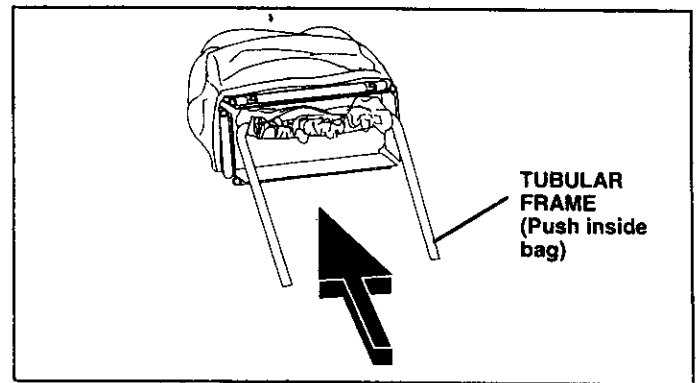

FIG. 3C

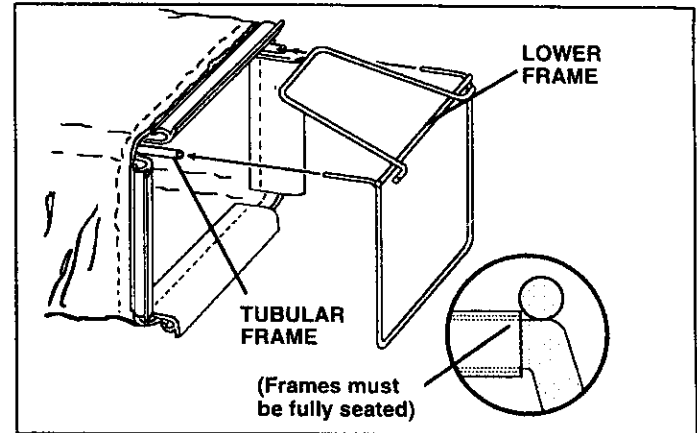

FIG. 3D

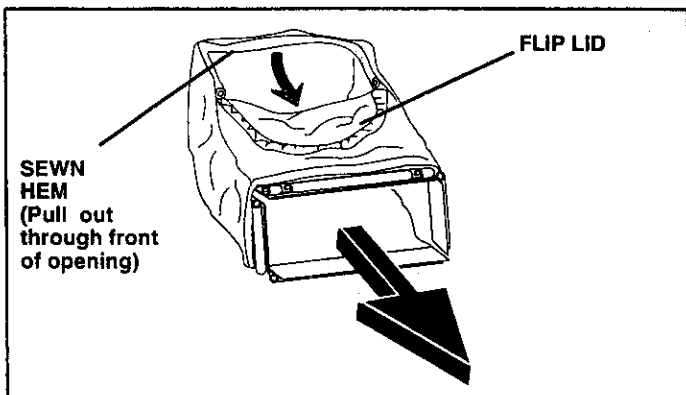

FIG. 3A

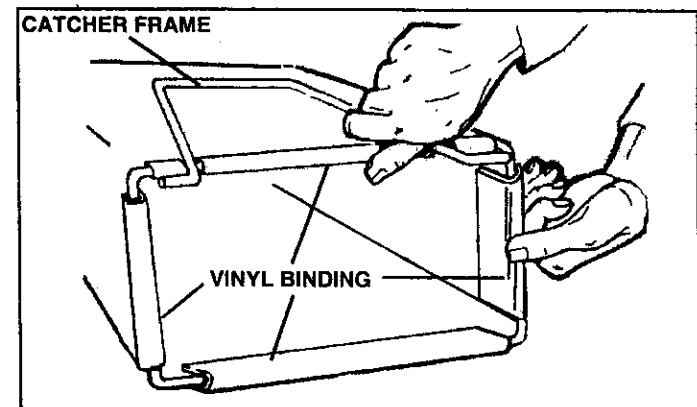

FIG. 3E

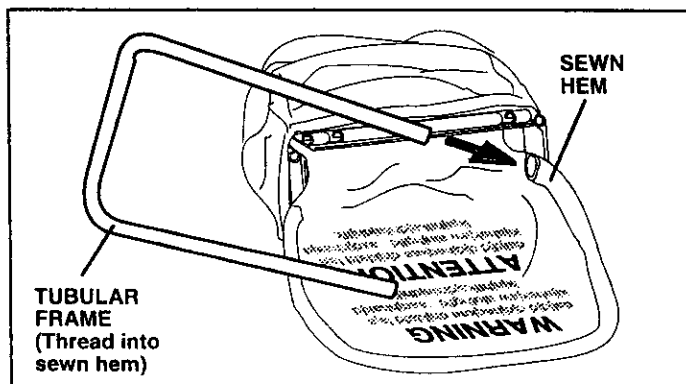

FIG. 3B

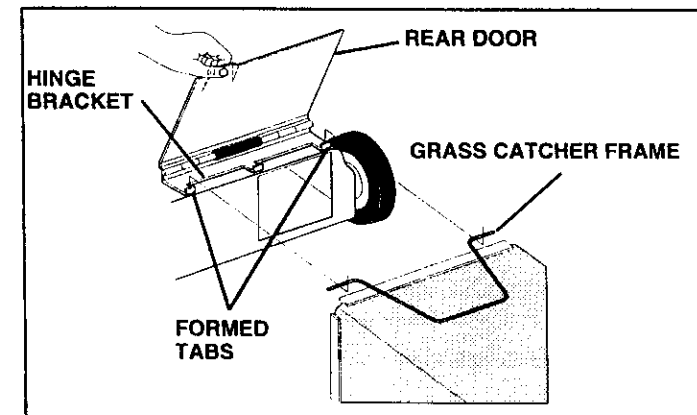

FIG. 4

OPERATION

KNOW YOUR LAWN MOWER

READ THIS OWNER'S MANUAL AND SAFETY RULES BEFORE OPERATING YOUR LAWN MOWER. Compare the illustrations with your lawn mower to familiarize yourself with the location of various controls and adjustments. Save the manual for future reference.

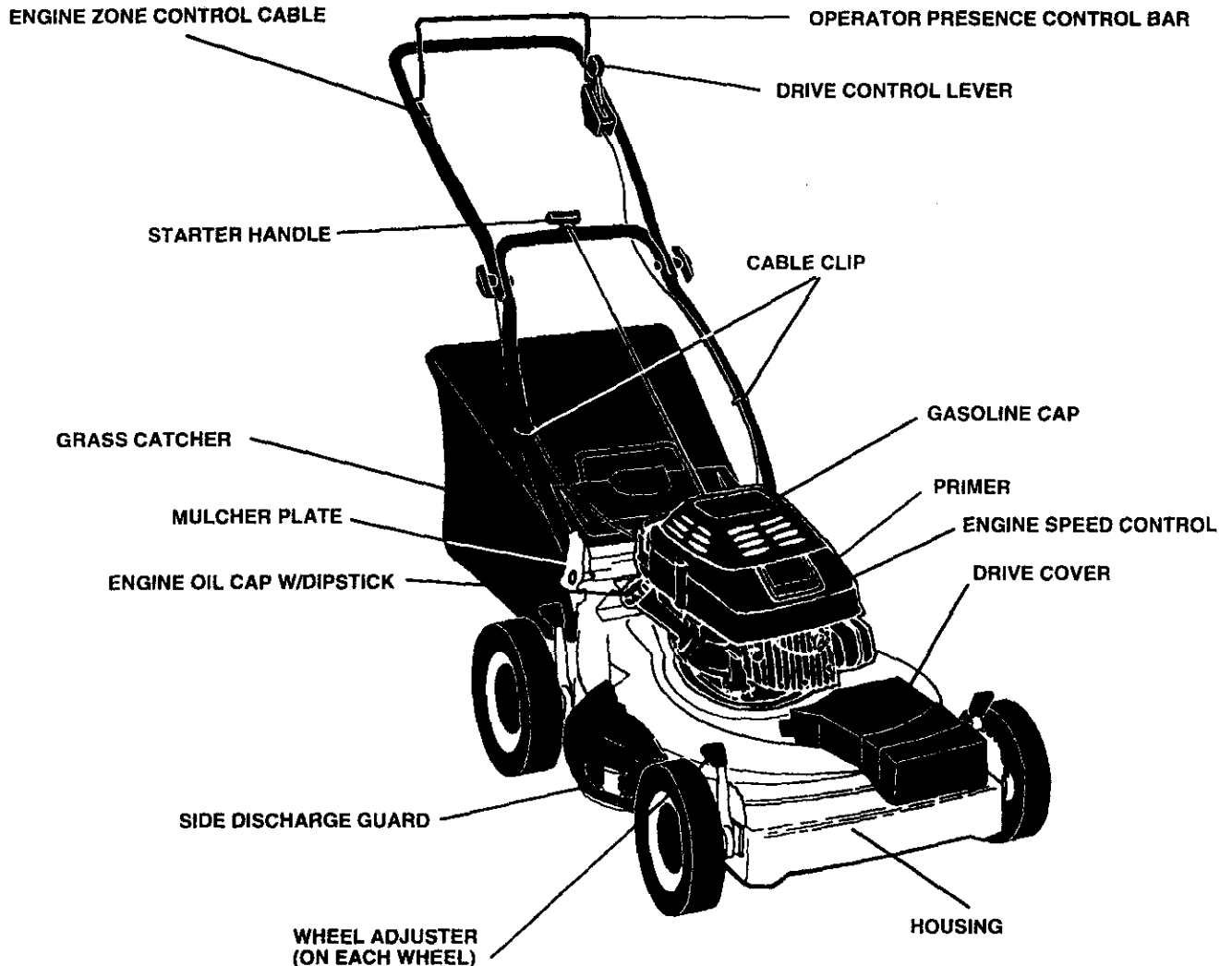

FIG. 5

MEETS CPSC SAFETY REQUIREMENTS

Sears rotary walk-behind power lawn mowers conform to the safety standards of the American National Standards Institute and the U.S. Consumer Product Safety Commission. The blade turns when the engine is running.

OPERATOR PRESENCE CONTROL - must be held down to the handle to start the engine. Release to stop the engine.

PRIMER - pumps additional fuel from the carburetor to the cylinder for use when starting a cold engine.

STARTER HANDLE - used for starting the engine.

DRIVE CONTROL LEVER - used to engage power-propelled forward motion of lawn mower.

ENGINE SPEED CONTROL - located on the side of the engine which allows you to select either fast (🔊) or slow (🔇) engine speed.

MULCHER PLATE - Located at the rear discharge opening must be removed when converting to bagging operation.

OPERATION

HOW TO USE YOUR LAWN MOWER

ENGINE SPEED (See Fig. 6)

The engine speed is controlled by a lever located on the side of the engine. Fast (↶) position is for starting the engine, normal cutting, and better grass bagging. Slow (↷) position is for light cutting, trimming and fuel economy.

ENGINE ZONE CONTROL



CAUTION: Federal regulations require an engine control to be installed on this lawn mower in order to minimize the risk of blade contact injury. Do not under any circumstances attempt to defeat the function of the operator control. The blade turns when the engine is running.

- Your lawn mower is equipped with an operator presence control bar which requires the operator to be positioned behind the lawn mower handle to start and operate the lawn mower.

DRIVE CONTROL (See Fig. 7)

- Self-propelling is controlled by holding the operator presence control bar down to the handle and pushing the drive control lever forward until it clicks; then release the lever.
- Forward motion will stop when the operator presence control bar is released. To stop forward motion without stopping engine, release the operator presence control bar slightly until the drive control disengages. Hold operator presence control bar down to handle to continue mowing without self-propelling.
- To keep drive control engaged when turning corners, push down on handle and lift front wheels off ground while turning lawn mower.

TO CONVERT MOWER

Your lawn mower was shipped ready to be used as a mulcher. To convert to rear bagging or side discharging, see "TO CONVERT MOWER" in Assembly section of this manual.



CAUTION: BEFORE ATTEMPTING TO CONVERT LAWN MOWER:

- Release control bar to stop engine.
- Make sure the blade and all moving parts have completely stopped.

TO ADJUST CUTTING HEIGHT (See Fig. 8)

- Raise wheels for low cut and lower wheels for high cut.
- Wheels are set in low cut for shipping. Adjust cutting height to suit your requirements. Medium position is best for most lawns.
- To change cutting height, squeeze adjuster lever toward wheel. Move wheel up or down to suit your requirements. Be sure all wheels are in the same setting.

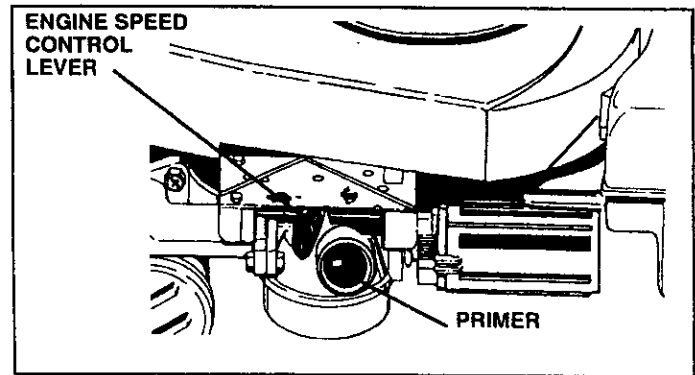

FIG. 6

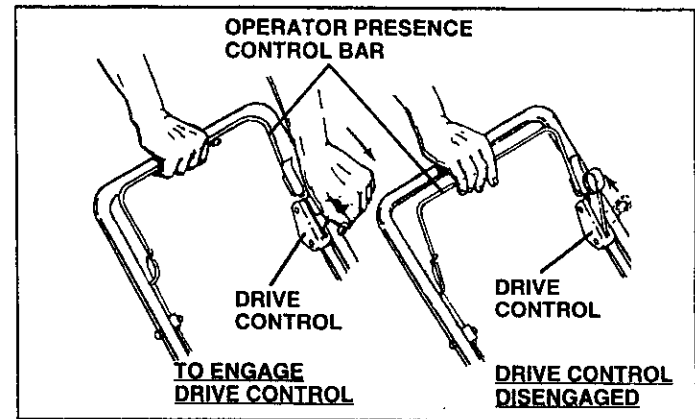

FIG. 7

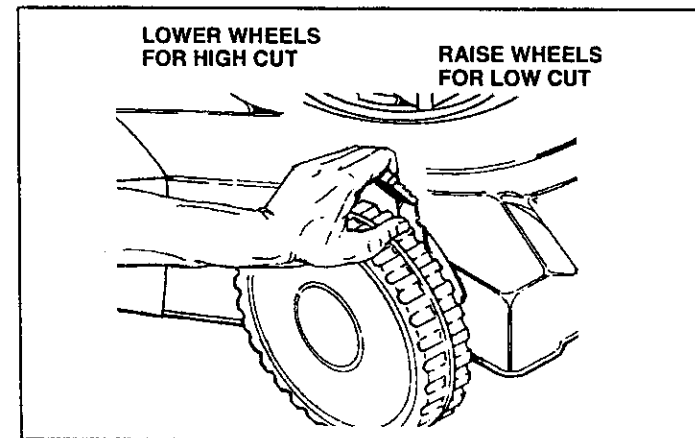

FIG. 8

OPERATION

TO EMPTY GRASS CATCHER (See Fig. 9)

- Simply lift up rear door and remove the grass catcher by the handle.

NOTE: Do not drag the bag when emptying; it will cause unnecessary wear.

BEFORE STARTING ENGINE OIL (See Fig. 10)

Your lawn mower is shipped without oil in the engine.

- Be sure mower is level and area around oil fill is clean.
- Remove engine oil cap w/dipstick and fill to the full line on the dipstick.
- Use 20 ozs. of oil. For type and grade of oil to use, see "ENGINE" in Customer Responsibilities section of this manual.
- Pour oil slowly. Do not over fill.
- Check oil level before each use. Add oil if needed. Fill to full line on dipstick.
- To read proper level, tighten engine oil cap each time.
- Reinstall engine oil cap and tighten.
- After the first two (2) hours of mowing, change the oil, and every 25 hours thereafter. You may need to change the oil more often under dusty, dirty conditions.

GAS (See Fig. 10)

- Fill gasoline tank with fresh, clean, unleaded gasoline. **DO NOT USE PREMIUM GASOLINE. BE CAREFUL NOT TO OVER FILL TANK.**

WARNING: Experience indicates that alcohol blended fuels (called gasohol or using ethanol or methanol) can attract moisture which leads to separation and formation of acids during storage. Acidic gas can damage the fuel system of an engine while in storage. To avoid engine problems, the fuel system should be emptied before storage of 30 days or longer. Drain the fuel tank, start the engine and let it run until fuel lines and carburetor are empty. Use fresh fuel next season. See Storage Instructions for additional information. Never use engine or carburetor cleaner products in fuel tank or permanent damage may occur.

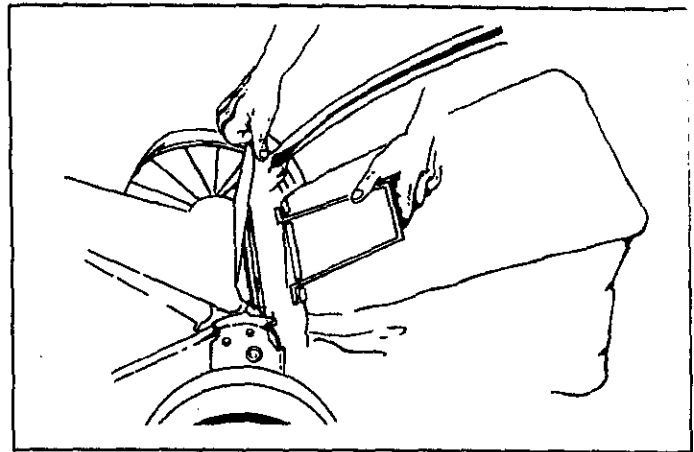

FIG. 9

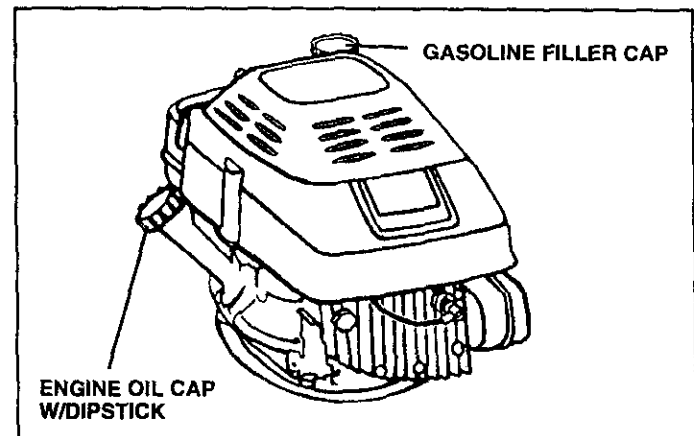

FIG. 10

TO START ENGINE

- To start a cold engine, push primer five (5) times before trying to start. Use a firm push. This step is not usually necessary when starting an engine which has already run for a few minutes.
- Push engine speed control lever to fast (⚡) position.
- Hold operator presence control bar down to the handle and pull starter handle quickly. Do not allow starter rope to snap back.
- To stop engine, release operator presence control bar.

NOTE: In cooler weather it may be necessary to repeat priming steps. In warmer weather over priming may cause flooding and engine will not start. If you do flood engine, wait a few minutes before attempting to start and do not repeat priming steps.

OPERATION

MOWING TIPS

- Under certain conditions, such as very tall grass, it may be necessary to raise the height of cut to reduce pushing effort and to keep from overloading the engine and leaving clumps of grass clippings.
- For extremely heavy cutting, reduce the width of cut by overlapping previously cut path and mow slowly.
- For better grass bagging and most cutting conditions, the engine speed should be set in the fast (←) position.
- When using a rear discharge lawn mower in moist, heavy grass, clumps of cut grass may not enter the grass catcher. Reduce ground speed (pushing speed) and/or run the lawn mower over the area a second time.
- If a trail of clippings is left on the right side of a rear discharge mower, mow in a clockwise direction with a small overlap to collect the clippings on the next pass.
- Pores in cloth grass catchers can become filled with dirt and dust with use and catchers will collect less grass. To prevent this, regularly hose catcher off with water and let dry before using.
- Keep top of engine around starter clear and clean of grass clippings and chaff. This will help engine air flow and extend engine life.

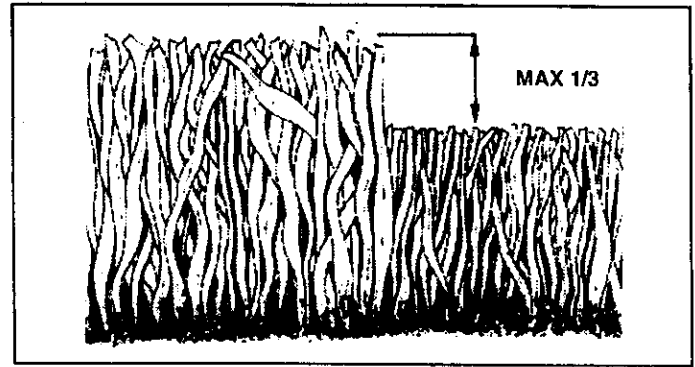

FIG. 11

MULCHING MOWING TIPS

IMPORTANT: FOR BEST PERFORMANCE, KEEP MOWER HOUSING FREE OF BUILT-UP GRASS AND TRASH. SEE "CLEANING" IN CUSTOMER RESPONSIBILITIES SECTION OF THIS MANUAL.

- The special mulching blade will recut the grass clippings many times and reduce them in size so that as they fall onto the lawn they will disperse into the grass and not be noticed. Also, the mulched grass will biodegrade quickly to provide nutrients for the lawn. Always mulch with your highest engine (blade) speed as this will provide the best recutting action of the blades.
- Avoid cutting your lawn when it is wet. Wet grass tends to form clumps and interferes with the mulching action. The best time to mow your lawn is the early afternoon. At this time the grass has dried and the newly cut area will not be exposed to the direct sun.
- For best results, adjust the lawn mower cutting height so that the lawn mower cuts off only the top one-third of the grass blades (See Fig. 11). If the lawn is overgrown it will be necessary to raise the height of cut to reduce pushing effort and to keep from overloading the engine and leaving clumps of mulched grass. For extremely heavy mulching, reduce your width of cut by overlapping previously cut path and mow slowly.
- Certain types of grass and grass conditions may require that an area be mulched a second time to completely hide the clippings. When doing a second cut, mow across or perpendicular to the first cut path.
- Change your cutting pattern from week to week. Mow north to south one week then change to east to west the next week. This will help prevent matting and graining of the lawn.

CUSTOMER RESPONSIBILITIES

MAINTENANCE SCHEDULE		SERVICE DATES																
		BEFORE EACH USE	AFTER EACH USE	FIRST 2 HOURS	EVERY 5 HOURS	EVERY 25 HOURS	EVERY SEASON	BEFORE STORAGE										
MOWER	Check for Loose Fasteners	✓						✓										
	Clean/Inspect Grass Catcher (If Equipped)	✓	✓								✓							
	Clean Lawn Mower		✓								✓							
	Inspect/Clean Drive Wheels (Self-Propelled Mowers)	✓			✓													
	Sharpen/Replace Mower Blade						✓ ₃											
	Lubrication Chart						✓				✓							
	Clean Battery/Recharge (Electric Start Mowers)						✓				✓ ₄							
ENGINE	Check Engine Oil Level	✓			✓													
	Change Engine Oil			✓		✓ _{1,2}												
	Clean Air Filter					✓ ₂												
	Inspect Muffler					✓												
	Replace Spark Plug								✓									
	Replace Air Filter Paper Cartridge								✓ ₂									

- 1 - Change more often when operating under a heavy load or in high ambient temperatures.
- 2 - Service more often when operating in dirty or dusty conditions.
- 3 - Replace blades more often when mowing in sandy soil.
- 4 - Charge 48 hours at end of season.

GENERAL RECOMMENDATIONS

The warranty on this lawn mower does not cover items that have been subjected to operator abuse or negligence. To receive full value from the warranty, operator must maintain mower as instructed in this manual.

Some adjustments will need to be made periodically to properly maintain your unit.

All adjustments in the Service and Adjustments section of this manual should be checked at least once each season.

- Once a year, replace the spark plug, replace air filter element and check blade for wear. A new spark plug and clean/new air filter element assures proper air-fuel mixture and helps your engine run better and last longer.
- Follow the maintenance schedule in this manual.

BEFORE EACH USE

- Check engine oil level.
- Check for loose fasteners.

LUBRICATION

Keep unit well lubricated (See "LUBRICATION CHART").

LUBRICATION CHART

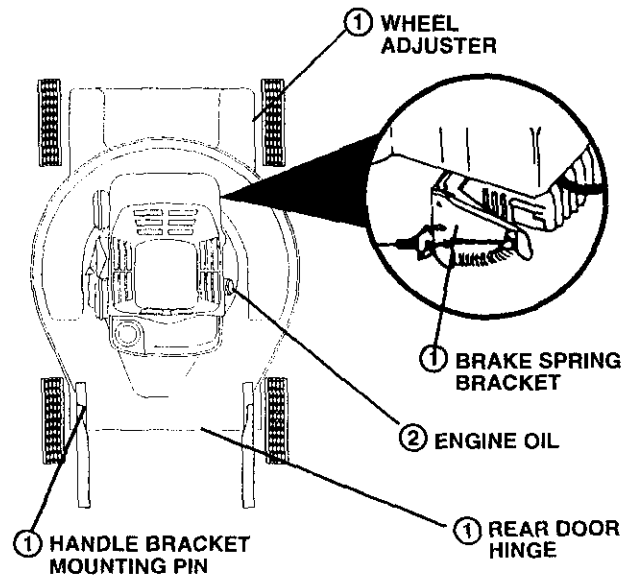

- ① SPRAY LUBRICANT
- ② REFER TO CUSTOMER RESPONSIBILITIES "ENGINE" SECTION.

IMPORTANT: DO NOT OIL OR GREASE PLASTIC WHEEL BEARINGS. VISCOUS LUBRICANTS WILL ATTRACT DUST AND DIRT THAT WILL SHORTEN THE LIFE OF THE SELF LUBRICATING BEARINGS. IF YOU FEEL THEY MUST BE LUBRICATED, USE ONLY A DRY, POWDERED GRAPHITE TYPE LUBRICANT SPARINGLY.

CUSTOMER RESPONSIBILITIES

LAWN MOWER

Always observe safety rules when performing any maintenance.

TIRES

- Keep tires free of gasoline, oil, or insect control chemicals which can harm rubber.
- Avoid stumps, stones, deep ruts, sharp objects and other hazards that may cause tire damage.

BLADE CARE

For best results, mower blade must be kept sharp. Replace bent or damaged blades.

TO REMOVE BLADE (See Fig. 12)

- Disconnect spark plug wire from spark plug and place wire where it cannot come in contact with spark plug.
- Turn lawn mower on its side. Make sure air filter and carburetor are up.
- Use a wood block between blade and mower housing to prevent blade from turning when removing blade bolt.
- Protect your hands with gloves and/or wrap blade with heavy cloth.
- Remove blade bolt by turning counter-clockwise.
- Remove blade and attaching hardware (bolt, lock washer and hardened washer).

NOTE: Remove the blade adapter and check the key inside hub of blade adapter. The key must be in good condition to work properly. Replace adapter if damaged.

TO REPLACE BLADE (See Fig. 12)

- Position the blade adapter on the engine crankshaft. Be sure key in adapter and crankshaft keyway are aligned.
- Position blade on the blade adapter aligning the two (2) holes in the blade with the raised lugs on the adapter.
- Be sure the trailing edge of blade (opposite sharp edge) is up toward the engine.
- Install the blade bolt with the lock washer and hardened washer into blade adapter and crankshaft.
- Use block of wood between blade and lawn mower housing and tighten the blade bolt, turning clockwise.
- The recommended tightening torque is 35-40 ft. lbs.

IMPORTANT: BLADE BOLT IS GRADE 8 HEAT TREATED.

NOTE: We do not recommend sharpening blade - but if you do, be sure the blade is balanced.

TO SHARPEN BLADE

Care should be taken to keep the blade balanced. An unbalanced blade will cause eventual damage to lawn mower or engine.

- The blade can be sharpened with a file or on a grinding wheel. Do not attempt to sharpen while on the mower.
- To check blade balance, drive a nail into a beam or wall. Leave about one inch of the straight nail exposed. Place center hole of blade over the head of the nail. If blade is balanced, it should remain in a horizontal position. If either end of the blade moves downward, sharpen the heavy end until the blade is balanced.

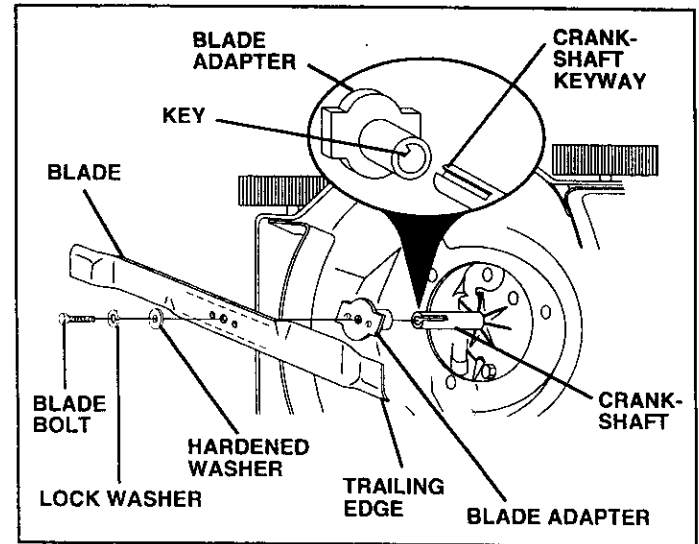

FIG. 12

GEAR CASE

- To keep your drive system working properly, the gear case and area around the drive should be kept clean and free of trash build-up. Clean under the drive cover twice a season.
- The gear case is filled with lubricant to the proper level at the factory. The only time the lubricant needs attention is if service has been performed on the gear case.
- If lubricant is required, use only Texaco Starplex Premium Grease, part no. 750369. Do not substitute.

DRIVE WHEELS

Check front drive wheels each time before you mow to be sure they move freely.

The wheels not turning freely means trash, grass cuttings, etc. are in the drive wheel area and must be cleaned to free drive wheels.

If necessary to clean the drive wheels, check both front wheels.

- Remove hubcaps, hairpin cotters and washers.
- Remove wheels from wheel adjusters.
- Remove any trash or grass cuttings from inside the dust cover, pinion and/or drive wheel gear teeth.
- Put wheels back in place.
- If after cleaning, the drive wheels do not turn freely, contact your nearest authorized service center.

GRASS CATCHER

- The grass catcher may be hosed with water, but must be dry when used.
- Check your grass catcher often for damage or deterioration. Through normal use it will wear. If catcher needs replacing, replace only with a manufacturer approved replacement catcher. Give the lawn mower model number when ordering.

CUSTOMER RESPONSIBILITIES

ENGINE LUBRICATION

Use only high quality detergent oil rated with API service classification SG. Select the oil's SAE viscosity grade according to your expected operating temperature.

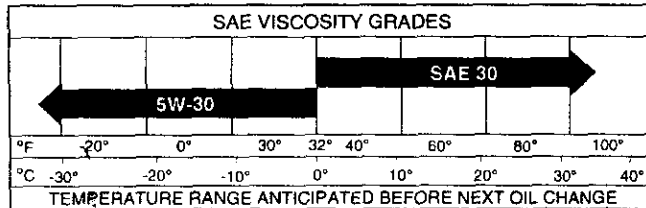

NOTE: Although multi-viscosity oils (5W30, 10W30 etc.) improve starting in cold weather, these multi-viscosity oils will result in increased oil consumption when used above 32°F. Check your engine oil level more frequently to avoid possible engine damage from running low on oil.

Change the oil after the first two hours of operation and every 25 hours thereafter or at least once a year if the lawn mower is not used for 25 hours in one year.

Check the crankcase oil level before starting the engine and after each five (5) hours of continuous use. Tighten oil plug securely each time you check the oil level.

TO CHANGE ENGINE OIL (See Fig. 13)

NOTE: Before tipping lawn mower to drain oil, drain fuel tank by running engine until fuel tank is empty.

- Disconnect spark plug wire from spark plug and place wire where it cannot come in contact with spark plug.
- Remove engine oil cap; lay aside on a clean surface.
- Tip lawn mower on its side and drain oil into a suitable container. Rock lawn mower back and forth to remove any oil trapped inside of engine.
- Wipe off any spilled oil on lawn mower and on side of engine.
- Fill engine with oil. Fill only to the "FULL" line on the dipstick. DO NOT OVER FILL.
- Replace engine oil cap.
- Reconnect spark plug wire to spark plug.

AIR FILTER

Your engine will not run properly and may be damaged by using a dirty air filter.

Replace the air filter every year, more often if you mow in very dusty, dirty conditions. Do not wash air filter.

TO CHANGE AIR FILTER (See Fig. 14)

- Remove the air filter cover by turning counterclockwise to the stop and pull away from collar.
- Remove filter from inside of cover.
- Clean the inside of the cover and the collar to remove any dirt accumulation.
- Insert new filter into cover.
- Put air filter cover and filter into collar aligning the tab with the slot.
- Push in on cover and turn clockwise to tighten.

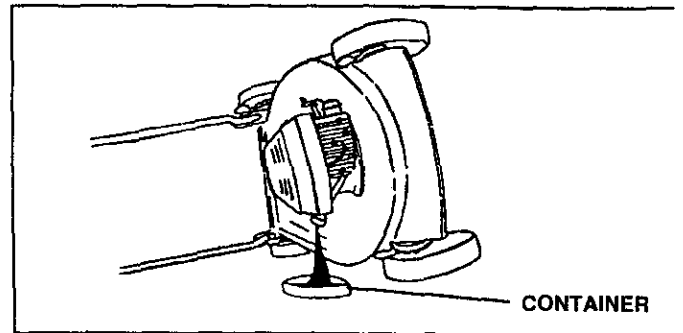

FIG. 13

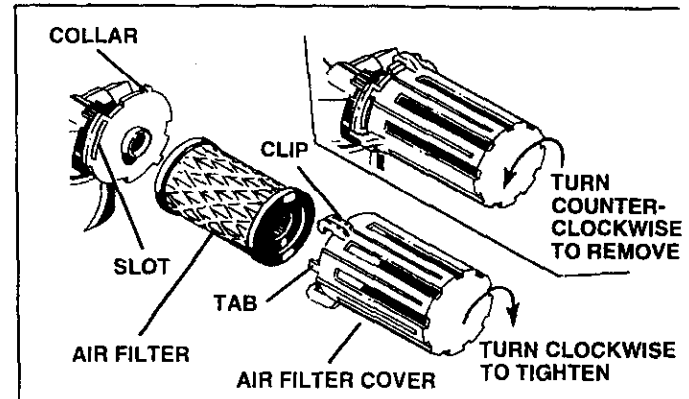

FIG. 14

MUFFLER

Inspect and replace corroded muffler as it could create a fire hazard and/or damage.

SPARK PLUG

Change your spark plug each year to make your engine start easier and run better. Set spark plug gap at .030 inch.

CLEANING

IMPORTANT: FOR BEST PERFORMANCE, KEEP MOWER HOUSING FREE OF BUILT-UP GRASS AND TRASH. CLEAN UNDERSIDE OF MOWER HOUSING AFTER EACH USE.



CAUTION: Disconnect spark plug wire from spark plug and place wire where it cannot come in contact with the spark plug.

- Turn lawn mower on its side. Make sure air filter and carburetor are up. Clean the underside of your lawn mower by scraping to remove build-up of grass and trash.
- Clean engine often to keep trash from accumulating. A clogged engine runs hotter and shortens engine life.
- Keep finished surfaces and wheels free of all gasoline, oil, etc.
- We do not recommend using a garden hose to clean lawn mower unless the electrical system, muffler, air filter and carburetor are covered to keep water out. Water in engine can result in shortened engine life.

CLEAN UNDER DRIVE COVER

Clean under drive cover at least twice a season. Scrape underside of cover with putty knife or similar tool to remove any build-up of trash or grass on underside of drive cover.

SERVICE AND ADJUSTMENTS



CAUTION: BEFORE PERFORMING ANY SERVICE OR ADJUSTMENTS:

- Release control bar.
- Make sure the blade and all moving parts have completely stopped.
- Disconnect spark plug wire from spark plug and place where it cannot come in contact with plug.

LAWN MOWER

TO ADJUST CUTTING HEIGHT

See "TO ADJUST CUTTING HEIGHT" in the Operation section of this manual.

REAR DEFLECTOR

The rear deflector, attached between the rear wheels of your lawn mower, is provided to minimize the possibility that objects will be thrown out the rear of the lawn mower into the operator's mowing position. If the rear deflector becomes damaged, it should be replaced.

TO REMOVE/REPLACE DRIVE BELT

(See Fig. 15)

- Remove drive cover. Remove belt by pushing down on gear case pulley.
- Turn lawn mower on its side with carburetor and fuel cap up.
- Remove blade.
- Remove debris shield.
- Remove belt from engine pulley on crankshaft.
- Install new belt by reversing above steps.
- Always use factory approved belt to assure fit and long life.

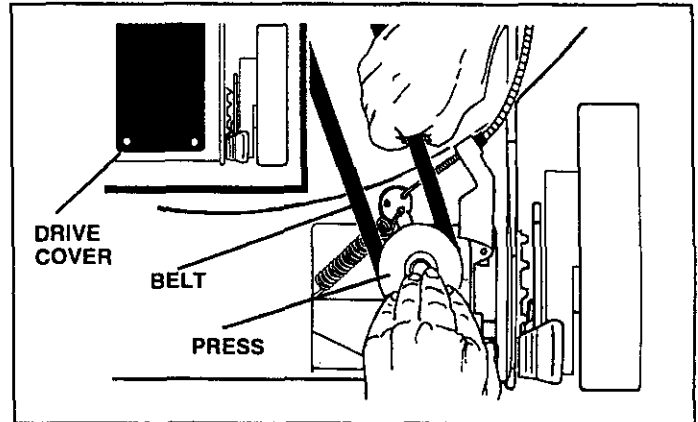

FIG. 15

SERVICE AND ADJUSTMENTS

TO ADJUST HANDLE (See Figs. 16 Thru 18)

Your lawn mower handle can be raised or lowered for your mowing comfort. Four (4) positions are available: high, medium high, medium low and low. Handles are shipped mounted in the medium low position.

- To change from medium low to medium high position, the upper and lower handle sections will have to be turned over (See Fig. 16B).
- Remove the controls and operator presence control bar from the upper handle.
- Remove the starter rope guide from the lower handle.
- Remove hairpin cotters.
- Disconnect the lower handle from the handle brackets (See Fig. 18).
- Turn the handle over and reassemble the hairpin cotters that have been removed.
- Reassemble the starter rope guide.
- Reassemble the controls and the operator presence control bar to the upper handle.



CAUTION: The operator presence control bar must pivot freely to permit blade brake engagement when control bar is released. Do not over tighten the fasteners holding the controls to the upper handle.

- To change from medium low to high position only the upper handle section will have to be turned over (See Fig. 17A).
- To change from medium low to low position, only the lower handle section will have to be turned over (See Fig. 17B).

ENGINE

ENGINE SPEED

Your engine speed has been factory set. Do not attempt to increase engine speed or it may result in personal injury. If you believe that the engine is running too fast or too slow, take your lawn mower to an authorized service center/department for repair and adjustment.

CARBURETOR

Your carburetor has a non-adjustable fixed main jet for mixture control. If your engine does not operate properly due to suspected carburetor problems, take your lawn mower to an authorized service center/department for repair and adjustment.

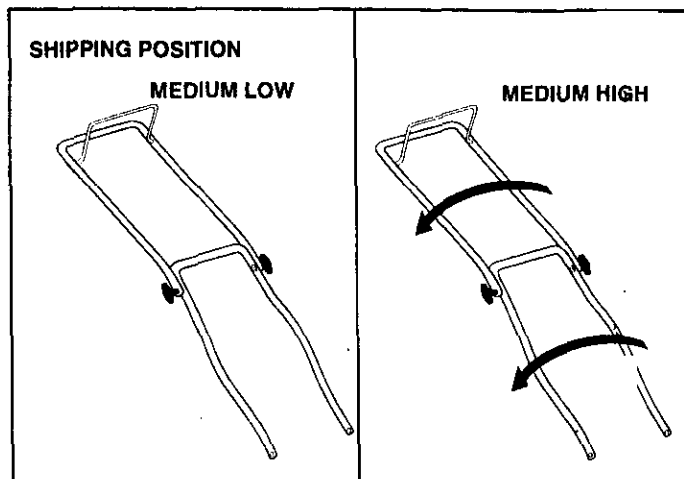

FIG. 16A

FIG. 16B

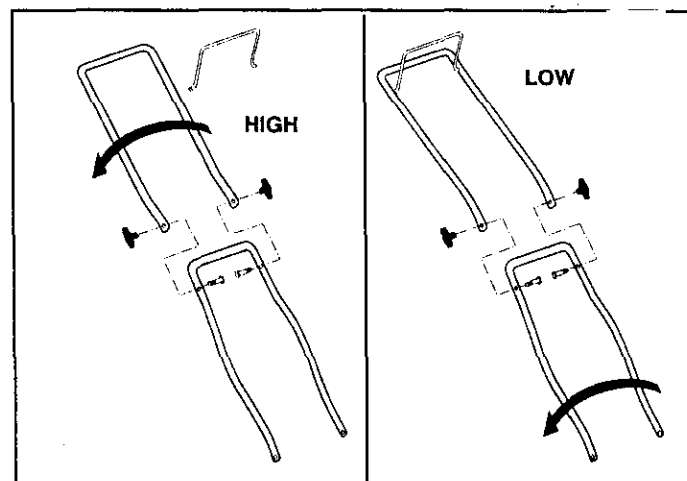

FIG. 17A

FIG. 17B

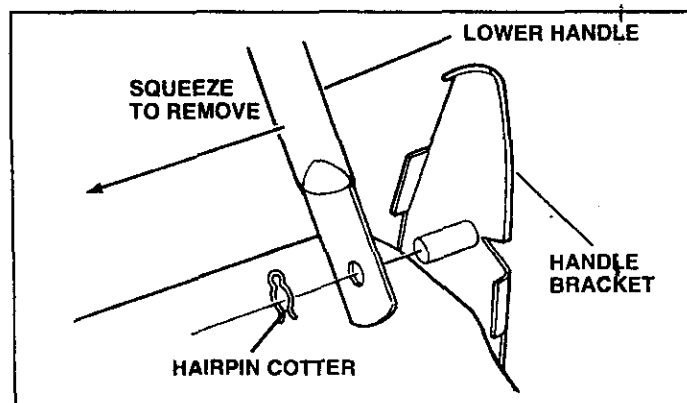

FIG. 18

STORAGE

Immediately prepare your lawn mower for storage at the end of the season or if the unit will not be used for 30 days or more.

LAWN MOWER

When lawn mower is to be stored for a period of time, clean it thoroughly, remove all dirt, grease, leaves, etc. Store in a clean, dry area.

- Clean entire lawn mower (See "CLEANING" in the Customer Responsibilities section of this manual).
- Lubricate as shown in the Customer Responsibilities section of this manual.
- Be sure that all nuts, bolts, screws, and pins are securely fastened. Inspect moving parts for damage, breakage and wear. Replace if necessary.
- Touch up all rusted or chipped paint surfaces; sand lightly before painting.

HANDLE (See Fig. 19)

You can fold your lawn mower handle for storage.

- Squeeze the bottom ends of the lower handle toward each other until the lower handle clears the handle bracket, then move handle forward.
- Loosen upper handle mounting bolts enough to allow upper handle to be folded back.

IMPORTANT: WHEN FOLDING THE HANDLE FOR STORAGE OR TRANSPORTATION, BE SURE TO FOLD THE HANDLE AS SHOWN OR YOU MAY DAMAGE THE CONTROL CABLES.

- When setting up your handle from the storage position, the lower handle will automatically lock into the mowing position.

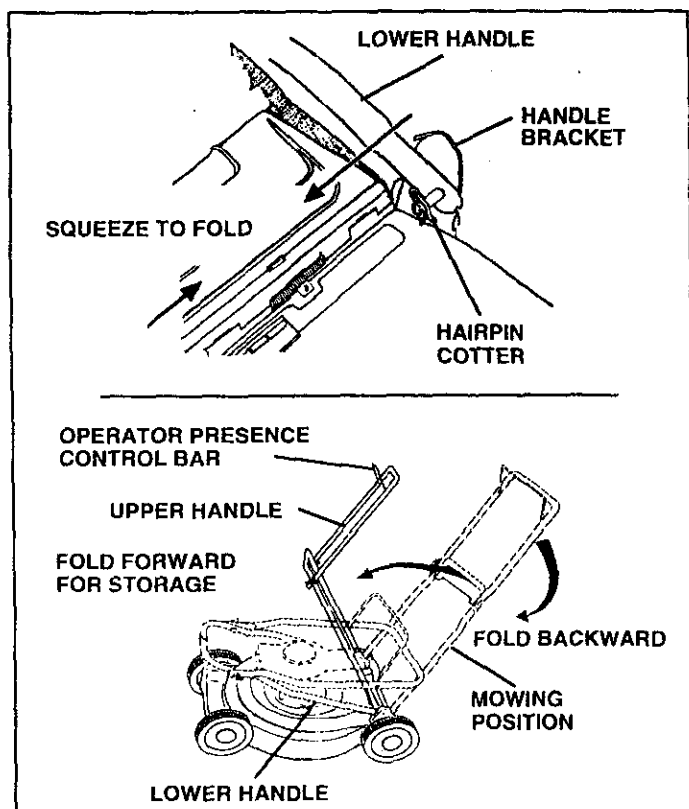

FIG. 19

ENGINE

FUEL SYSTEM

IMPORTANT: IT IS IMPORTANT TO PREVENT GUM DEPOSITS FROM FORMING IN ESSENTIAL FUEL SYSTEM PARTS SUCH AS CARBURETOR, FUEL FILTER, FUEL HOSE, OR TANK DURING STORAGE. ALSO, EXPERIENCE INDICATES THAT ALCOHOL BLENDED FUELS (CALLED GASOHOL OR USING ETHANOL OR METHANOL) CAN ATTRACT MOISTURE WHICH LEADS TO SEPARATION AND FORMATION OF ACIDS DURING STORAGE. ACIDIC GAS CAN DAMAGE THE FUEL SYSTEM OF AN ENGINE WHILE IN STORAGE.

- Drain the fuel tank.
- Start the engine and let it run until the fuel lines and carburetor are empty.
- Never use engine or carburetor cleaner products in the fuel tank or permanent damage may occur.
- Use fresh fuel next season.

NOTE: Fuel stabilizer is an acceptable alternative in minimizing the formation of fuel gum deposits during storage. Add stabilizer to gasoline in fuel tank or storage container. Always follow the mix ratio found on stabilizer container. Run engine at least 10 minutes after adding stabilizer to allow the stabilizer to reach the carburetor. Do not drain the gas tank and carburetor if using fuel stabilizer.

ENGINE OIL

Drain oil (with engine warm) and replace with clean engine oil. (See "ENGINE" in the Customer Responsibilities section of this manual).

CYLINDER

- Remove spark plug.
- Pour one ounce (29 ml) of oil through spark plug hole into cylinder.
- Pull starter handle slowly a few times to distribute oil.
- Replace with new spark plug.

OTHER

- Do not store gasoline from one season to another.
- Replace your gasoline can if your can starts to rust. Rust and/or dirt in your gasoline will cause problems.
- If possible, store your unit indoors and cover it to give protection from dust and dirt.
- Cover your unit with a suitable protective cover that does not retain moisture. Do not use plastic. Plastic cannot breathe which allows condensation to form and will cause your unit to rust.

IMPORTANT: NEVER COVER MOWER WHILE ENGINE AND EXHAUST ARE STILL WARM.

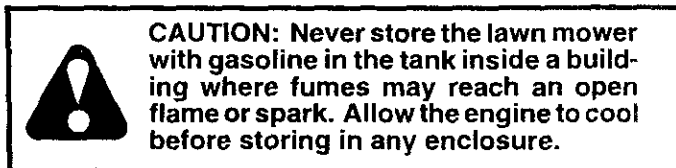

REPAIR PARTS

CRAFTSMAN 22" ROTARY LAWN MOWER MODEL NUMBER 917.373980

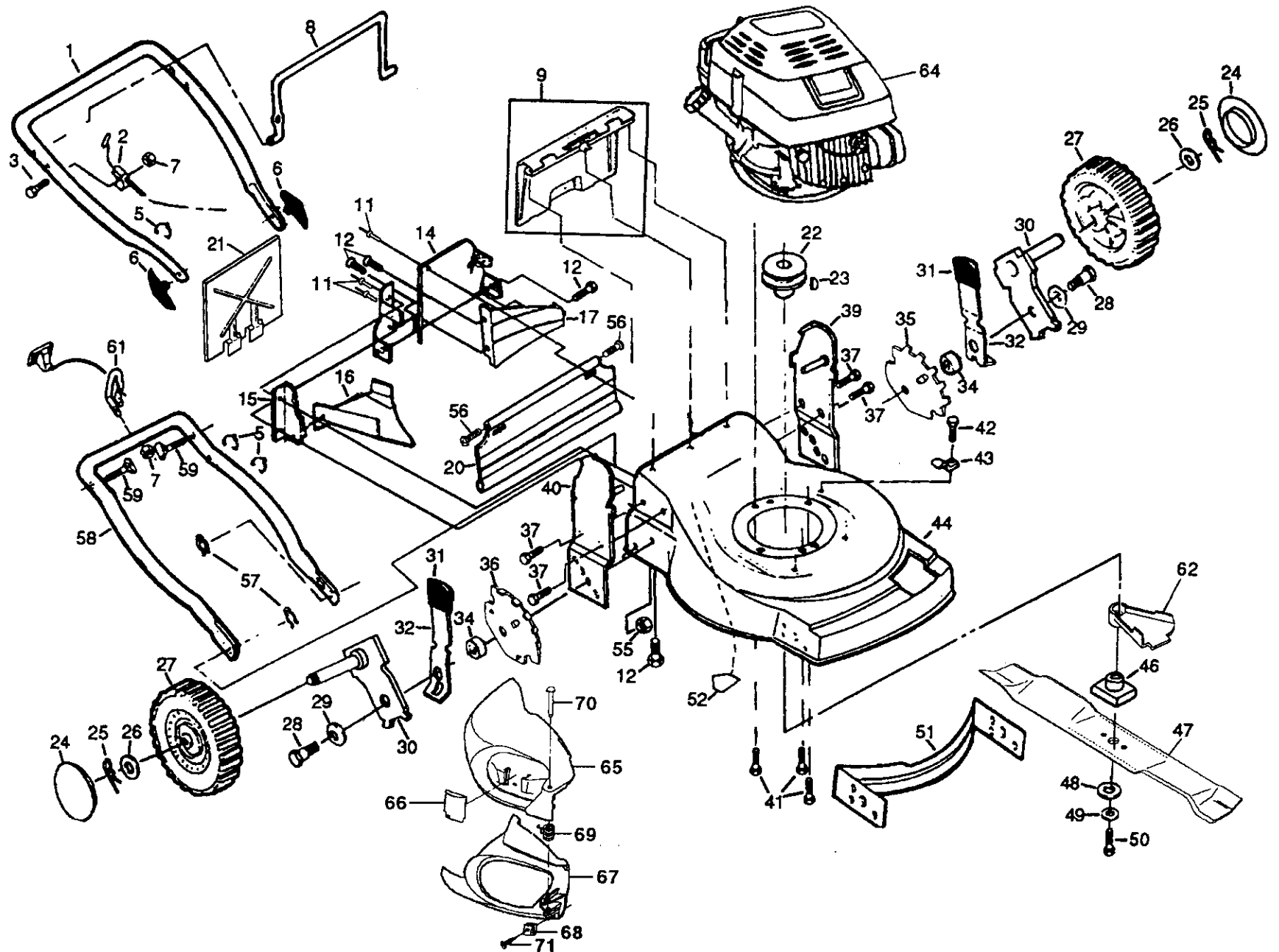

REPAIR PARTS

CRAFTSMAN 22" ROTARY LAWN MOWER MODEL NUMBER 917.373980

19

KEY NO.	PART NO	DESCRIPTION
1	133088X479	Upper Handle
2	130861	Engine Zone Control Cable
3	74350424	Hex Head Bolt 1/4-20 x 1-1/2
5	85827	Cable Clip
6	136376	Handle Knob
7	STD541425	Locknut 1/4-20
8	851509	Control Bar
9	48137	Rear Door Kit
11	128415	Pop Rivets
12	STD512505	Hex Tapping Screw 1/4-20 x 1/2
14	700483X479	Back Plate
15	700365X479	Side Baffle
16	133190X479	Discharge Baffle
17	140661X479	Rear Baffle
20	140540	Rear Skirt
21	133170X479	Mulcher Plate
22	85543	Engine Pulley
23	87677	Hi-Pro Key #505
24	77400	Hubcap
25	85179	Retainer Clip
26	52160	Washer
27	700781	Wheel & Tire Assembly
28	84921	Shoulder Bolt 3/8-16
29	62335	Belleville Washer
30	85021X004	Axle Arm Assembly
31	701037	Selector Knob
32	850855X004	Selector Spring
34	84920	Spacer
35	133759X007	Wheel Adjusting Bracket (Left)
36	133757X007	Wheel Adjusting Bracket (Right)
37	55187	Thread Cutting Screw 5/16-18 x 3/4
39	140629X459	Handle Bracket Assembly (Left)
40	140628X459	Handle Bracket Assembly (Right)
41	850998	Hex Head Thread Rolling Screw 3/8-16 x 1-1/8
42	750097	Hex Washer Head Screw #10-24 x 1/2

KEY NO.	PART NO	DESCRIPTION
43	87930	Guide Clip
44	48377	Lawn Mower Housing (Incl. Key #14,15,51 &52)
46	851514	Blade Adapter
47	141114	Blade 22"
48	851074	Hardened Washer
49	850263	Helical Washer 3/8-24 x 1-3/8 Grd. 8
50	851084	Hex Head Machine Screw 3/8-24 x 1-3/8 Grd. 8
51	700869X479	Front Baffle
52	85463	Danger Decal
55	751592	Locknut 3/8-16
56	88652	Hinge Screw
57	51793	Hairpin Cotter
58	84676X479	Lower Handle
59	131959	Handle Bolt
61	103672X	Rope Guide
62	134612	Debris Shield
64	141137	Engine - Craftsman - Model No. 143.945504
65	701458	Door
66	752240X479	Door Latch
67	702807	Side Discharge Guard
68	141839	Speed Nut
69	702808	Hinge Spring
70	702809	Hinge Rod
71	141841	Screw
--	141763	Decal
--	142413	Owner's Manual (English)
--	142414	Owner's Manual (Spanish)

Available accessories not included with lawn mower:

<u>71</u>	33723	High Wheel Kit
<u>71</u>	33623	Gas Can (2.5 gal.)
<u>71</u>	33500	Fuel Stabilizer
<u>71</u>	33300	SAE 30W Oil (20 oz.).
<u>71</u>	33417	Dust Shield
<u>71</u>	33316	Mower Cover

REPAIR PARTS

CRAFTSMAN 22" ROTARY LAWN MOWER MODEL NUMBER 917.373980

20

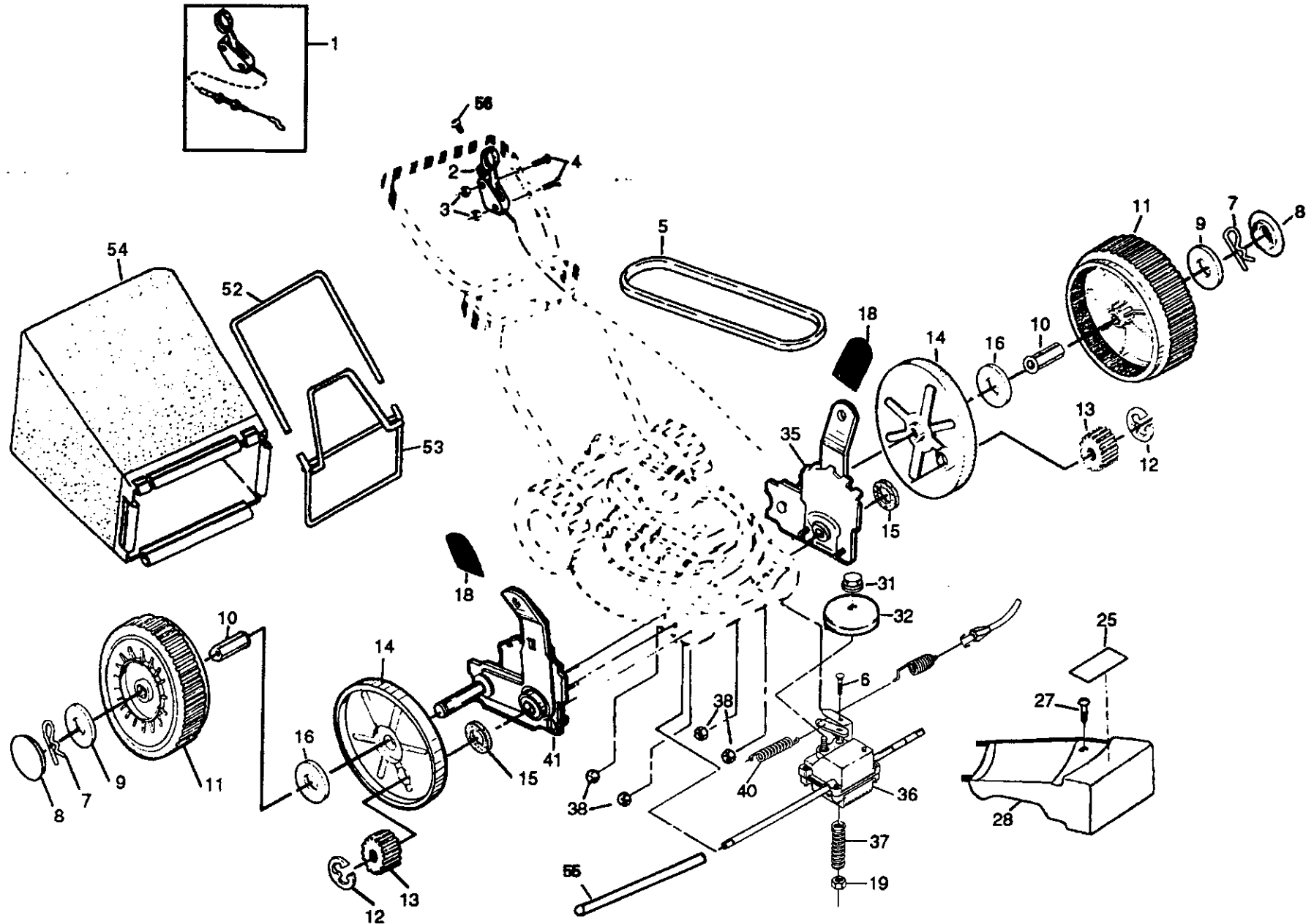

REPAIR PARTS

CRAFTSMAN 22" ROTARY LAWN MOWER MODEL NUMBER 917.373980

KEY NO.	PART NO.	DESCRIPTION	KEY NO.	PART NO.	DESCRIPTION
1	48029	Drive Head Kit	19	63601	Hex Locknut 1/4-20
2	137076	Drive Control	25	141764	Drive Cover Decal
3	69180	Locknut #10-24	27	143603	Hex Washer Head Screw #10-24 x 3/4
4	750029	Pan Head Machine Screw #10-24 x 2	28	702806	Drive Cover
5	137078	V-Belt	31	132010	Hex Flange Nut
6	700875	Carriage Bolt 1/4-20 x 2-3/4	32	137052	Drive Pulley
7	85179	Retainer Clip	35	751809	Wheel Adjuster Assembly (Left)
8	77400	Hubcap	36	702511	Gear Case Assembly
9	52160	Washer	37	137090	Spring
10	86960	Nylon Bushing	38	STD541425	Hex Locknut 1/4-20
11	700783	Wheel & Tire Assembly	40	75192	Spring
12	12000058	E-Ring	41	751810	Wheel Adjuster Assembly (Right)
13	137054	Pinion	52	701242	Catcher Frame
14	88080	Dust Cover	53	701243	Frame Tube
15	88118	Felt Washer	54	141245	Grassbag Assembly
16	67725	Washer 1/2 x 1-1/2 x .134	55	86012	Driveshaft Cover
18	701037	Selector Knob	56	851552	Hi-Lo Pan Head Screw #10-16 x 1/2

REPAIR PARTS

22" ROTARY LAWN MOWER -- MODEL NO. 917.373980

GEAR CASE ASSEMBLY PART NUMBER 702511

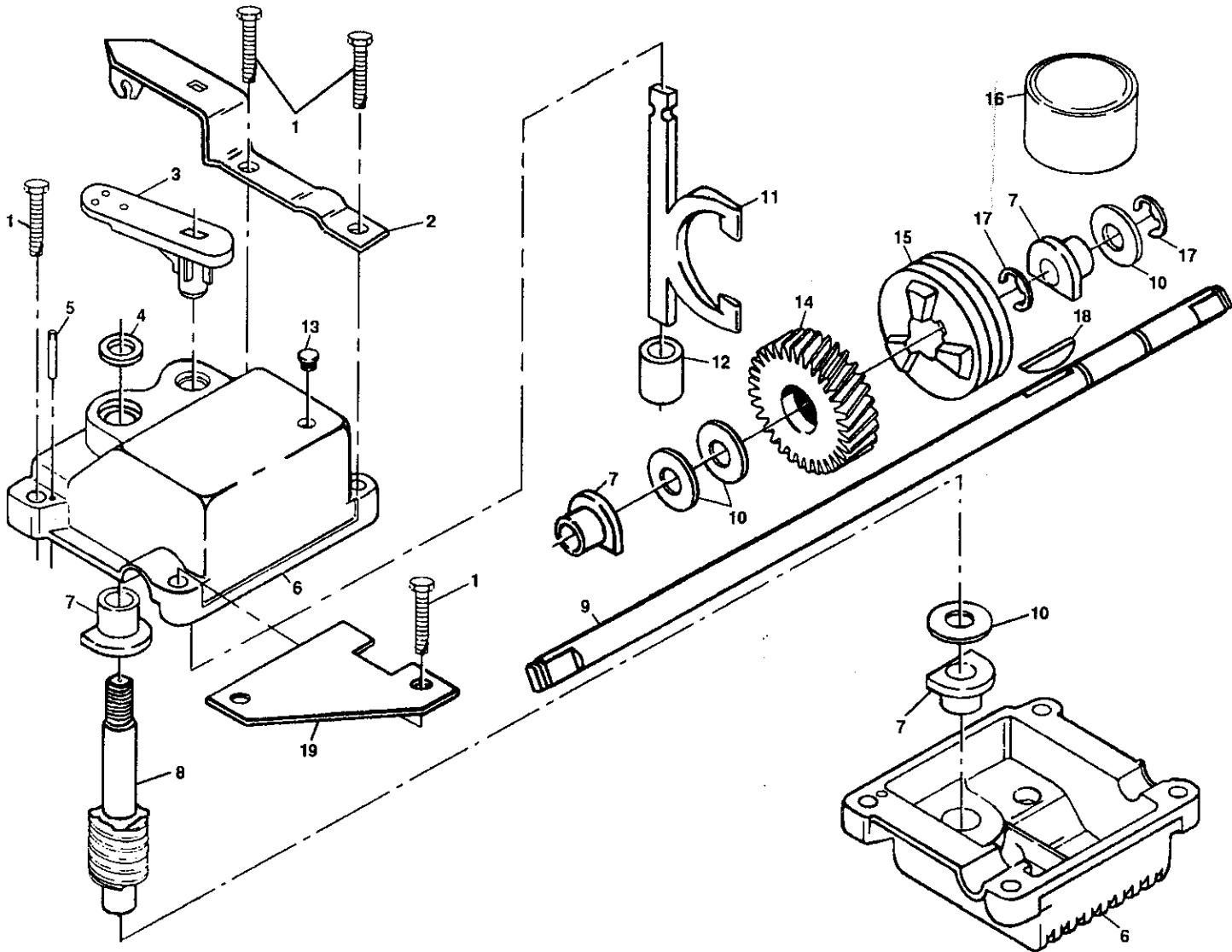

KEY NO.	PART NO.	DESCRIPTION
1	17490416	Tapping Screw 1/4-20 x 1-1/4
2	137055X004	Engagement Bracket
3	137053	Shifter
4	57072	Seal
5	702710	Grooved Pin 1/8 x 5/8
6	48373	Gear Case Halves Kit (Includes Key Nos. 4, 5, and 7)
7	77881	Bearing
8	137051	Worm Shaft
9	137074	Drive Shaft
10	57079	Hardened Washer
11	131484	Clutch Yoke
12	700343	Bushing

KEY NO.	PART NO.	DESCRIPTION
13	86447	Plug
14	137050	Helical Gear
15	750436X	Clutch Jaw
16	750369	Grease
17	12000003	E-Ring
18	850848	Hi-Pro Key
19	81585X004	Spring Bracket

NOTE: To reseal housing halves use Loctite No. 515, Part No. 77923

NOTE: All component dimensions given in U.S. inches.
1 inch = 25.4 mm

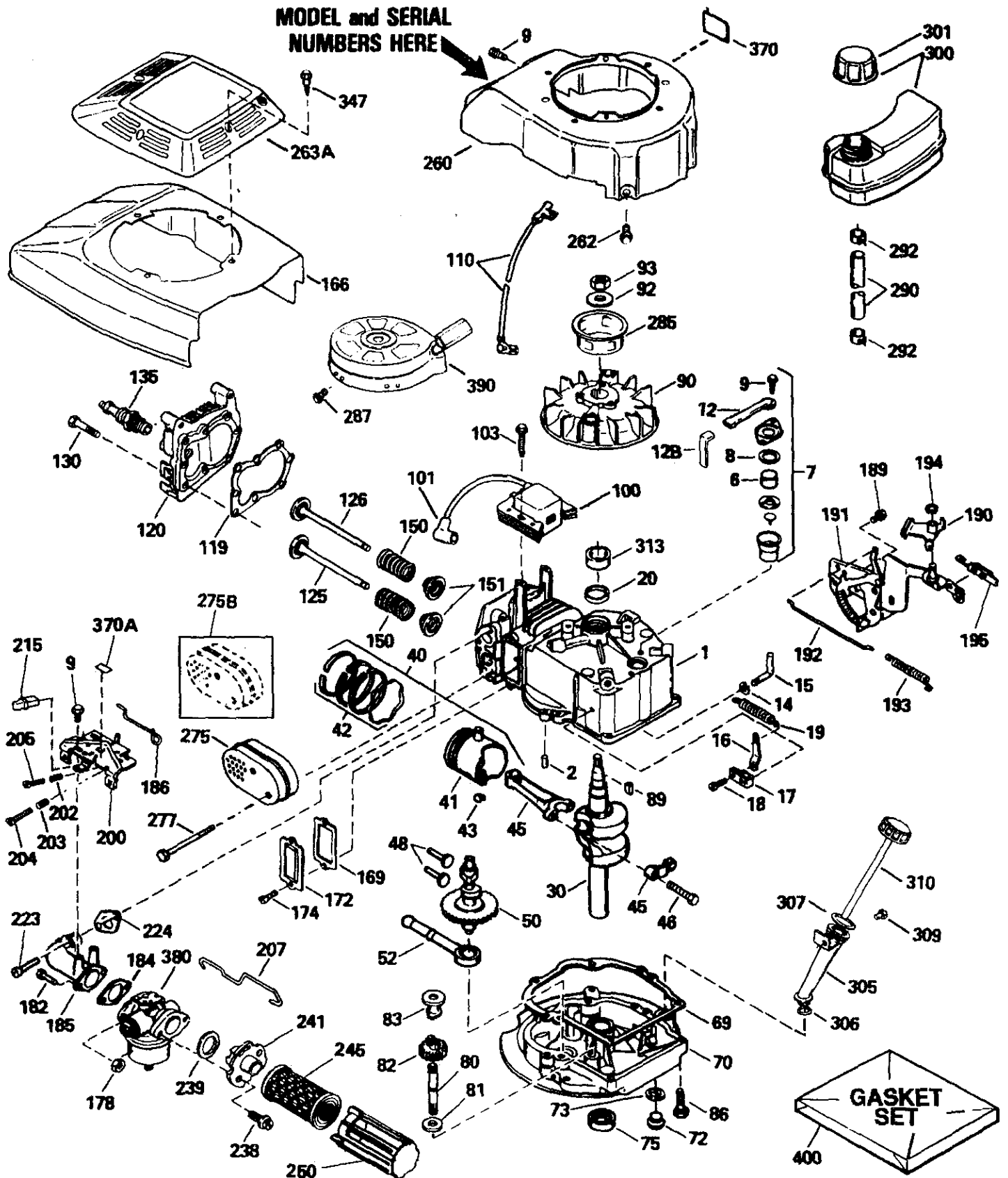

REF NO.	PART NO.	DESCRIPTION	REF NO.	PART NO.	DESCRIPTION
1	36478	Cylinder (Includes Ref. #2 and 20)	169	27234A	* Valve Cover Gasket
2	26727	Dowel Pin	172	32755	Valve Cover
6	33734	Breather Element	174	30200	Screw #10-24 x 9/16
7	34214A	Breather Assembly (Includes Reference #6, 8, 9, 12 and 12B)	178	29752	Nut & Lock Washer 1/4-28
8	33735	* Breather Gasket	182	6201	Screw 1/4-28 x 7/8
9	30200	Screw #10-24 x 9/16	184	26756	* Carburetor To Intake Pipe Gasket
12	33886	Breather Tube	185	31384A	Intake Pipe (Includes Ref. #224)
12B	34695	Breather Tube Elbow	186	34337	Governor Link
14	28277	Washer	189	650839	Screw 1/4-20 x 3/8
15	30589	Governor Rod (Includes Ref. #14)	190	35831	Brake Lever
16	31383A	Governor Lever	191	35039B	S.E. Brake Bracket (Includes #195)
17	31335	Governor Lever Clamp	192	34966	Brake Control Link
18	650548	Screw #8-32 x 5/16	193	34965	Brake Spring
19	36281	Extension Spring	194	32309	Retaining Ring
20	32600	Oil Seal	195	610973	Terminal
30	35801	Crankshaft	200	35727	Control Bracket (Incl. #202-205)
40	36073	Piston, Pin & Ring Set, Std. Size	202	36482	Compression Spring
	36074	Piston, Pin & Ring Set, .010" Over	203	31342	Compression Spring
	36075	Piston, Pin & Ring Set, .020" Over	204	650549	Screw #5-40 x 7/16
41	36070	Piston & Pin Assembly, Std. Size	205	650777	Screw #6-32 x 21/32
	36071	Piston & Pin Assembly, .010" Over	207	34336	Throttle Link
	36072	Piston & Pin Assembly, .020" Over (Assemblies Include Reference #43)	215	35511	Control Knob
42	36076	Ring Set, Piston, Standard Size	223	650451	Screw 1/4-20 x 1
	36077	Ring Set, Piston, .010" Oversize	224	34690A	* Intake Pipe Gasket
	36078	Ring Set, Piston, .020" Oversize	238	650932	Screw #10-32 x 49/64
43	20381	Piston Pin Retaining Ring	239	34338	* Air Cleaner Gasket
45	32875	Connecting Rod Assy. (Incl. #46)	241	35797	Air Cleaner Collar
46	32610A	Connecting Rod Bolt	245	35066	Air Cleaner Filter
48	27241	Valve Lifter	250	35065	Air Cleaner Cover
50	35992	Camshaft (MCR)	260	35826	Blower Housing
52	29914	Oil Pump Assembly	262	650831	Screw #1/4-20 x 1/2
69	35261	* Mounting Flange Gasket	263A	35821	Starter Grill
70	34311D	Mounting Flange (Incl. #72 thru 83)	275	36473	Muffler (Includes Reference #277)
72	30572	Oil Drain Plug	275B	391020	Spark Arrestor Muffler (Optional)
73	28833	Drain Plug Gasket	277	650795	Screw 1/4-20 x 2-1/4
75	27897	Oil Seal	285	35000	Starter Cup
80	30574A	Governor Shaft	287	650926	Screw #8-32 x 21/64
81	30590A	Washer	290	34357	Fuel Line
82	30591	Governor Gear Assy. (Incl. #81)	292	26460	Fuel Line Clamp
83	30588A	Governor Spool	300	35586	Fuel Tank (Includes #292 and 301)
86	650488	Screw 1/4-20 x 1-1/4	301	35355	Fuel Cap
89	611004	Flywheel Key	305	35819A	Oil Fill Tube
90	611109	Flywheel	306	34265	* O-Ring
92	650815	Belleville Washer	307	35499	O-Ring
93	650816	Flywheel Nut	309	650936	Screw #10-32 x 13/32
100	34443A	Solid State Ignition	310	35822	Dipstick
101	610118	Spark Plug Cover	313	34080	Spacer
103	650814	Screw, Torx T-15 #10-24 x 1	347	650898	Screw #10-32 x 27/32
110	34961	Ground Wire	370	36261	Instruction Decal
119	36477	* Cylinder Head Gasket	370A	35167	Instruction Decal
120	36476	Cylinder Head	380	632681	Carburetor (Includes Ref. #184)
125	36471	Exhaust Valve, Standard Size	390	590702	Rewind Starter
	36472	Exhaust Valve, 1/32" Oversize	400	36481	Gasket Set (Incl. items marked*)
126	29314B	Intake Valve, Standard Size			
	29315C	Intake Valve, 1/32" Oversize (All Valves Include Reference #151)			
130	6021A	Screw 5/16-18 x 1-1/2			
135	35395	Resistor Spark Plug (RJ19LM)			
150	35991	Valve Spring			
151	31673	Valve Spring Cap			
166	35827	Engine Shroud			

NOTE: This engine could have been built with starter #590637. Refer to the design of the air intake louvers for part identification (individual starter parts do not interchange).

RPM Settings: Low: 2450-2750, High: 2900-3200

NOTE: All component dimensions given in U.S. inches
1 inch = 25.4 mm

CRAFTSMAN 4-CYCLE ENGINE

MODEL NO. 143.945504

CARBURETOR NO. 632681

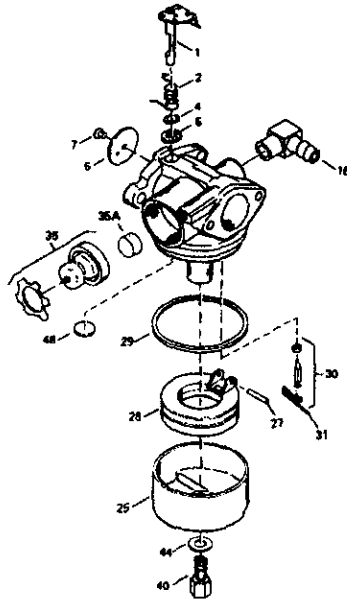

REF PART NO.	NO.	DESCRIPTION
--	632681	Carburetor, Complete (Includes Ref. #184 of Engine Parts List)
1	631615	Throttle Shaft and Lever Assembly
2	631767	Throttle Return Spring
4	631184	Dust Seal Washer
5	631183	Dust Seal, Throttle
6	632504	Throttle Shutter
7	650506	Shutter Screw
16	631775	Fuel Fitting
25	631867	Float Bowl
27	631024	Float Shaft
28	632019	Float
29	631028	Float Bowl O-Ring
30	631021	Inlet Needle, Seat and Clip (Includes Reference Number 31)
31	631022	Spring Clip
35	36045	Primer Bulb/Retainer Ring
35A	632647	Primer Bulb Filter
40	632682	High Speed Bowl Nut
44	27110	Bowl Nut Washer
48	631027	Welch Plug, Atmospheric Vent

REWIND STARTER NO. 590702

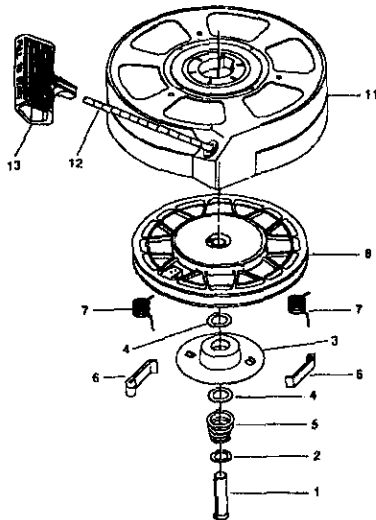

REF PART NO.	NO.	DESCRIPTION
--	590702	Recoil Starter, Complete
1	590599A	Spring Pin (Includes Reference #4)
2	590600	Washer
3	590696	Retainer
4	590601	Washer
5	590697	Brake Spring
6	590698	Starter Dog
7	590699	Dog Spring
8	590700	Pulley & Rewind Spring Assembly
11	590703	Starter Housing Assembly (40 Degree Grommet)
12	590535	Starter Rope (98" Long, 9/64" Dia.)
13	590701	Starter Handle

NOTE: All component dimensions given in U.S. inches
1 inch = 25.4 mm

REWIND STARTER NO. 590637

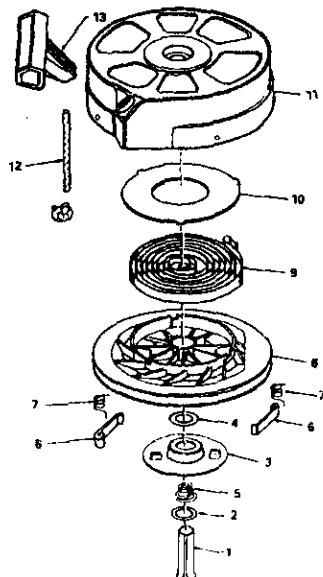

REF PART NO.	NO.	DESCRIPTION
--	590637	Recoil Starter, Complete
1	590599A	Spring Pin (Includes Reference #4)
2	590600	Washer
3	590615	Retainer
4	590601	Washer
5	590598	Brake Spring
6	590616	Starter Dog
7	590617	Dog Spring
8	590618A	Pulley & Rewind Spring Assembly (Includes Reference #9 and 10)
9	590619	Spring, Rewind
10	590620	Cover, Spring
11	590638	Starter Housing Assembly (40 Degree Grommet)
12	590535	Starter Rope (98" Long, 9/64" Dia.)
13	590452	Starter Handle

NOTE: All component dimensions given in U.S. inches
1 inch = 25.4 mm

SERVICE NOTES

TROUBLESHOOTING POINTS

PROBLEM	CAUSE	CORRECTION
Does not start	<ol style="list-style-type: none"> 1. Dirty air filter. 2. Out of fuel. 3. Stale fuel. 4. Water in fuel. 5. Spark plug wire is disconnected. 6. Bad spark plug. 7. Loose blade or broken blade adapter. 8. Control bar in released position 9. Control bar defective 	<ol style="list-style-type: none"> 1. Clean/replace air filter. 2. Fill fuel tank. 3. Drain tank and refill with fresh clean fuel. 4. Drain fuel tank and carburetor and refill tank with fresh gasoline. 5. Connect wire to plug. 6. Replace spark plug. 7. Tighten blade bolt or replace blade adapter. 8. Depress control bar to handle. 9. Replace control bar.
Loss of power	<ol style="list-style-type: none"> 1. Rear of lawn mower housing/blade dragging in heavy grass. 2. Cutting too much grass. 3. Dirty air filter. 4. Buildup of grass, leaves and trash under mower. 5. Too much oil in engine. 6. Walking speed too fast. 	<ol style="list-style-type: none"> 1. Set in "Higher Cut" position. 2. Set in "Higher Cut" position. 3. Clean/replace air filter. 4. Clean underside of mower housing. 5. Check oil level. 6. Cut at slower walking speed.
Poor cut - uneven	<ol style="list-style-type: none"> 1. Worn, bent or loose blade. 2. Wheel heights uneven. 3. Low engine speed. 4. Buildup of grass, leaves, and trash under mower. 	<ol style="list-style-type: none"> 1. Replace blade. Tighten blade bolt. 2. Set all wheels at same height. 3. Set engine speed control in HIGH position. 4. Clean underside of mower housing.
Excessive vibration	<ol style="list-style-type: none"> 1. Worn, bent or loose blade. 2. Bent engine crankshaft. 	<ol style="list-style-type: none"> 1. Replace blade. Tighten blade bolt. 2. Contact Sears Service Department.
Starter rope hard to pull	<ol style="list-style-type: none"> 1. Engine flywheel brake is on when control bar is released. 2. Bent engine crankshaft 3. Blade adapter broken. 4. Blade dragging in grass. 	<ol style="list-style-type: none"> 1. Depress control bar to upper handle before pulling starter rope. 2. Contact Sears Service Department. 3. Replace blade adapter. 4. Move lawn mower to cut grass or to hard surface to start engine.
Loss of drive	<ol style="list-style-type: none"> 1. Drive wheels not turning with drive control engaged. 2. Belt not driving. 	<ol style="list-style-type: none"> 1. Adjust or replace drive control cable, if broken. 2. Put belt on pulleys or replace belts if broken.
Grass catcher not filling (if so equipped)	<ol style="list-style-type: none"> 1. Cutting height too low. 2. Lift on blade worn off. 3. Catcher not venting air. 4. Low engine speed. 	<ol style="list-style-type: none"> 1. Raise cutting height. 2. Replace blade. 3. Clean grass catcher. 4. Set engine speed control in HIGH position.
Hard to push	<ol style="list-style-type: none"> 1. Grass is too high or wheel height is too low. 2. Rear of lawn mower housing/blade dragging in grass. 3. Grass catcher too full. 4. Handle height position not right for you. 	<ol style="list-style-type: none"> 1. Raise cutting height. 2. Raise rear of lawn mower housing one (1) setting higher. 3. Empty grass catcher. 4. Adjust handle height to suit.

SEARS

**OWNER'S
MANUAL**

**MODEL NO.
917.373980**

**IF YOU NEED
REPAIR SERVICE
OR PARTS:**

FOR REPAIR SERVICE, CALL
THIS TOLL FREE NUMBER:

1-800-4-REPAIR
(1-800-473-7247)

FOR REPLACEMENT PARTS
INFORMATION AND
ORDERING, CALL THIS
TOLL FREE NUMBER:

1-800-FON-PART
(1-800-366-7278)

CRAFTSMAN®

**5.5 HORSEPOWER
22" 3 in ONE Convertible
POWER PROPELLED
ROTARY LAWN MOWER**

Each lawn mower has its own model number. Each engine has its own model number.

The model number for your lawn mower will be found on a decal attached to the rear of the lawn mower housing.

The model number for your engine will be found on the blower housing of the engine.

All parts listed herein may be ordered from any Sears, Roebuck and Co. Service Center/Department and most Retail Stores.

**WHEN ORDERING REPAIR PARTS, ALWAYS GIVE THE
FOLLOWING INFORMATION:**

- **PRODUCT - LAWN MOWER**
- **MODEL NUMBER - 917.373980**
- **ENGINE MODEL NO. - 143.945504**
- **PART NUMBER**
- **PART DESCRIPTION**

Your Sears merchandise has added value when you consider Sears has service units nationwide staffed with Sears trained technicians... professional technicians specifically trained to insure that we meet our pledge to you, we service what we sell.