

# Operating Guide & Warranty



9" Color TV/VCR Combination

TVSC0902

# TABLE OF CONTENTS

<ul style="list-style-type: none"> <li>■ <b>IMPORTANT SAFEGUARDS</b> .....3</li> <li>■ <b>SPECIFICATIONS</b> .....5</li> <li>■ <b>SUPPLIED ACCESSORIES</b> .....5</li> <li>■ <b>PRECAUTIONS</b> .....6                     <ul style="list-style-type: none"> <li>Location .....6</li> <li>Avoid the Hazards of Electrical Shock and Fire .....6</li> <li>CAUTION .....6</li> </ul> </li> <li>■ <b>FEATURES</b> .....7</li> <li>■ <b>VIDEO CASSETTE</b> .....8</li> <li>■ <b>OPERATING CONTROLS AND FUNCTIONS</b> .....9</li> <li>■ <b>PREPARATION FOR USE</b> .....11                     <ul style="list-style-type: none"> <li>Antenna/Cable Connections .....11</li> <li>Mobile Connection .....12</li> <li>Installing the Batteries .....13</li> <li>External Input Mode .....13</li> </ul> </li> <li>■ <b>SET UP FOR USE</b> .....14                     <ul style="list-style-type: none"> <li>Channel Set Up for the First Time .....14</li> <li>Deleting (or Adding) Channel .....14</li> <li>Channel Set Up Again .....15</li> <li>Selecting the Language .....15</li> <li>Daylight-Saving Time .....15</li> <li>Clock Set Up (Auto / Manual) .....16</li> </ul> </li> <li>■ <b>ON-SCREEN DISPLAY</b> .....18</li> <li>■ <b>SPECIAL FEATURES</b> .....18                     <ul style="list-style-type: none"> <li>Degaussing .....18</li> <li>Real Time Tape Counter .....18</li> <li>Auto Rewind-Eject .....18</li> </ul> </li> <li>■ <b>TV OPERATION</b> .....19                     <ul style="list-style-type: none"> <li>Watching a TV Program .....19</li> <li>Game Mode .....19</li> <li>Picture Control .....19</li> </ul> </li> </ul>	<ul style="list-style-type: none"> <li>■ <b>PLAYBACK</b> .....20                     <ul style="list-style-type: none"> <li>Normal Playback .....20</li> <li>Tracking Adjustment .....20</li> <li>Picture Search .....20</li> <li>Still Picture .....20</li> <li>Noise line Reduction (in the Still mode) .....20</li> <li>Vertical Hold Control .....20</li> </ul> </li> <li>■ <b>SPECIAL PLAYBACK</b> .....21                     <ul style="list-style-type: none"> <li>Rental Playback .....21</li> <li>Auto Repeat Playback .....21</li> </ul> </li> <li>■ <b>SEARCH</b> .....22                     <ul style="list-style-type: none"> <li>Zero Return .....22</li> <li>Time Search .....22</li> </ul> </li> <li>■ <b>RECORDING</b> .....23                     <ul style="list-style-type: none"> <li>Normal Recording .....23</li> <li>Skipping Unwanted</li> <li>Scenes During Recording .....23</li> <li>OTR (One Touch Recording) .....24</li> <li>Copying a Video Cassette</li> <li>(Requires a VCR or camcorder) .....24</li> </ul> </li> <li>■ <b>TIMER</b> .....25                     <ul style="list-style-type: none"> <li>Automatic Timer Recording .....25</li> <li>Timer Program Extension .....26</li> <li>Auto Return .....27</li> <li>Wake Up Timer .....28</li> <li>Sleep Timer .....28</li> </ul> </li> <li>■ <b>MAINTENANCE</b> .....29</li> <li>■ <b>TROUBLESHOOTING GUIDE</b> .....30</li> </ul>
--	---

## FULL 90 DAY WARRANTY

For 90 days from the date of purchase, Sears will repair any defect in material or workmanship in this TV/VCR combination, free of charge. For one year from the date of purchase, Sears will supply, at no charge, replacement for defective parts.

The above warranty coverage applies only to TV/VCR combinations which are used for private household purposes.

TO OBTAIN WARRANTY SERVICE, SIMPLY RETURN THE TV/VCR COMBINATION TO THE NEAREST SEARS SERVICE CENTER IN THE UNITED STATES.

This warranty gives you specific legal rights, and you may also have other rights which vary from state to state.

**Sears Roebuck and Co., Dept. 817WA Hoffman Estates, IL 60179**  
**For the location of a Sears Service Center in your area : 1-800-488-1222**

**WARNING:** To reduce the risk of fire or electric shock, do not expose this appliance to rain or moisture.



The above CAUTION is located on the back of the TV/VCR cabinet.

**CAUTION:** To reduce the risk of electric shock, do not remove cover (or back). No user serviceable parts inside. Refer servicing to qualified service personnel.



This symbol indicates that dangerous voltage constituting a risk of electric shock is present within this unit.



This symbol indicates that there are important operating and maintenance instructions in the literature accompanying the appliance.

## IMPORTANT SAFEGUARDS

- 1. Read instructions**-Read all safety and operating instructions before operating this appliance.
- 2. Save Instructions**-Save these safety and operating instructions for future reference.
- 3. Heed Warnings**-Adhere to all warnings and cautions on the appliance and in this operating guide.
- 4. Follow Instructions**-Follow all safety and operation instructions.
- 5. Cleaning**-Unplug TV/VCR from the wall outlet before cleaning. Do not use liquid cleaners or aerosol cleaners. Use a damp cloth for cleaning.
- 6. Attachments**-Do not use attachments not recommended by the TV/VCR manufacturer as they may cause hazards.
- 7. Water and Moisture**-Do not use this TV/VCR near water, for example, near a bath tub, wash bowl, kitchen sink, or laundry tub, in a wet basement, or near a swimming pool, and the like.
- 8. Accessories**-Do not place this TV/VCR on an unstable cart, stand, tripod, bracket, or table. The TV/VCR may fall, causing serious injury to someone, and serious damage to the appliance. Use only with a cart, stand, tripod, bracket, or table recommended by the manufacturer, or sold with the TV/VCR. Any mounting of the appliance should follow the manufacturer's instructions and should use a mounting accessory recommended by the manufacturer. An appliance and cart combination should be moved with care. Quick stops, excessive force, and uneven surfaces may cause the appliance and cart combination to overturn.
- 9. Ventilation**-There are slots and openings in the TV/VCR cabinet to provide ventilation and protect it from overheating. **These openings must not be blocked or covered.** Do not place the TV/VCR on a bed, sofa, rug, or similar surface that will cause the ventilation openings to be blocked. Never place the TV/VCR near or over a radiator or heat register. Never place the TV/VCR in a built-in installation such as a bookcase or rack unless proper ventilation space is provided for it according to the instructions in this owner's manual.
- 10. Power Sources**-This TV/VCR should be operated only from the type of power source indicated on the marking label. If you are not sure of the type of power supply to your home, consult your appliance dealer or local power company. For TV/VCRs intended to operate from battery power, or other sources, refer to the operating instructions.
- 11. Grounding or Polarization**-This TV/VCR is equipped with a polarized alternating-current line plug (a plug having one blade wider than the other). This plug will fit into the power outlet only one way. This is a safety feature. If you are unable to insert the plug fully into the outlet, try reversing the plug. If the plug should still fail to fit, contact your electrician to replace your obsolete outlet. Do not defeat the safety purpose of the polarized plug.
- 12. Power-Cord Protection**-Route power supply cords so that they are not likely to be walked on or pinched by items placed on or against them. Take special care to keep all TV/VCR plug and cord-exit points clear of contact with other items.

PORTABLE CART WARNING



S3126A

**FIGURE A**  
**EXAMPLE OF ANTENNA GROUNDING AS PER**  
**NATIONAL ELECTRICAL CODE**

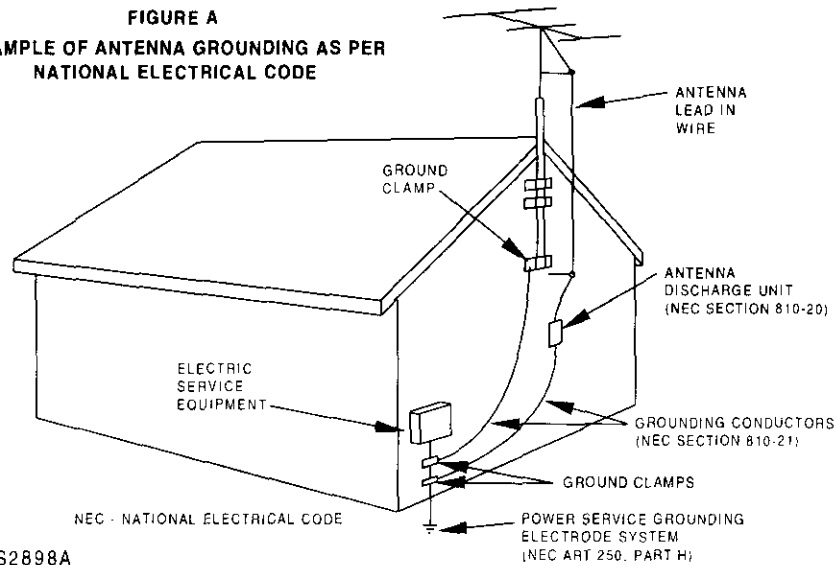

S2898A

**13. Outdoor Antenna grounding**-If an outside antenna or cable system is connected to the TV/VCR, be sure the antenna or cable system is grounded so as to provide some protection against voltage surges and built-up static charges. Article 810 of the National Electrical Code, ANSI/NFPA No. 70, provides information with respect to proper grounding of the mast and supporting structure, grounding of the lead-in wire to an antenna discharge unit, size of grounding conductors, location of antenna-discharge unit, connection to grounding electrodes, and requirements for the grounding electrode. (Fig. A)

**14. Lightning**-During a lightning storm, or before leaving it unattended and unused for a long period of time, unplug the TV/VCR from the wall outlet, and disconnect the antenna or cable system. This will prevent damage to the TV/VCR from lightning and power-surges.

**15. Power Lines**-An outside antenna system should not be located in the vicinity of overhead power lines or other electric light or power circuits, or where it can fall into power lines or circuits. When installing an outside antenna system, extreme care should be taken to keep from touching power lines or circuits, as contact with them might be fatal.

**16. Overloading**-Do not overload wall outlets and extension cords as this can result in a risk of fire or electric shock.

**17. Object and Liquid Entry**-Never push objects of any kind into this TV/VCR through openings as they may touch dangerous voltage points or short out parts that could result in a fire or electric shock. Never spill liquid of any kind on the TV/VCR.

**18. Servicing**-Do not attempt to service this TV/VCR yourself as opening or removing covers may expose you to dangerous voltage or other hazards. Refer all servicing to qualified service personnel.

**19. Damage Requiring Service**-Unplug this TV/VCR from the wall outlet and refer servicing to qualified service personnel under the following conditions:

- a. When the power-supply cord or plug is damaged or frayed.
- b. If liquid has been spilled, or objects have fallen into the TV/VCR.
- c. If the TV/VCR has been exposed to rain or water.
- d. If the TV/VCR does not operate normally by following the operating instructions. Adjust only those controls that are covered by the operating instructions, as improper adjustment of other controls may result in damage and will often require extensive work by a qualified technician to restore the TV/VCR to its normal operation.
- e. If the TV/VCR has been dropped or damaged in any way.
- f. When the TV/VCR exhibits a distinct change in performance it needs to be serviced.

**20. Replacement Parts**-When replacement parts are required, be sure the service technician has used replacement parts specified by the manufacturer that have the same characteristics as the original part. Unauthorized substitutions may result in fire, electric shock, injury to persons or other hazards.

**21. Safety Check**-Upon completion of any service or repairs to this TV/VCR, ask the service technician to perform routine safety checks to determine that the TV/VCR is in proper operating condition.

**22. Heat**- This TV/VCR product should be situated away from heat sources such as radiators, heat registers, stoves, or other products (including amplifiers) that produce heat.

The serial number of this product is found on the back of the unit. Record the serial number and other vital information here and retain this book as a permanent record of your purchase to aid identification in case of theft.

Date of Purchase	
Store Address	
Store Phone Number	
Model Number	
Serial Number	

## SPECIFICATIONS

### GENERAL SPECIFICATIONS

CRT : 9 inch in-line gun, 90° deflection tube  
 Television system : NTSC-M  
 Video Heads : Rotary two-head  
 Tape width : 1/2 inch  
 Tape speed  
   SP : 33.40mm/sec.  
   LP : 16.67mm/sec.  
   SLP : 11.12mm/sec.  
 Tuner channel  
   TV VHF Low : #2~#6  
   TV VHF High : #7~#13  
   TV UHF : #14~#69  
 CATV  
   VHF : 5A  
   MID band : A5~A1, A~I  
   SUPER band : J~W  
   HYPER band : W+1~W+84  
 Terminals  
   Antenna input : VHF/UHF 75 ohms unbalanced  
   Video input : RCA connector × 1  
   Audio input : RCA connector × 1  
   Earphone : 1/8" monaural (3.5 mm)

### ELECTRICAL SPECIFICATIONS

Video input level : 0.5~2.0Vp-p  
 Audio input level : -15dBs  
   Video S/N ratio : More than 46dB  
   Audio S/N ratio : More than 43dB

### OTHER SPECIFICATIONS

Power requirement : AC 120V/60Hz  
                           DC 13.2V  
 Power consumption : AC/DC 60W  
 Dimensions : H:13" (330mm)  
                   W:12-1/8" (308mm)  
                   D:12-15/16" (329mm)  
 Weight : 18.7 lbs (8.5 kg)

- **Designs and specifications are subject to change without notice and without our legal obligation.**



As an ENERGY STAR® Partner, Sears has determined that this product meets the ENERGY STAR® guidelines for energy efficiency. ENERGY STAR® is a U.S. registered mark.

## SUPPLIED ACCESSORIES

- Remote Control - Part No. N0118UD
  - Dipole Antenna
  - Matching Adapter
  - Two(2) AA Batteries
  - Car Adapter Cord
  - AC Cord
- **To order a replacement Remote Control, call 1-800-366-7278.**

# PRECAUTIONS

## Location

For safe operation and satisfactory performance of your TV/VCR, keep the following in mind when selecting a place for its installation:

- Shield it from direct sunlight and keep it away from sources of intense heat.
- Avoid dusty or humid places.
- For proper heat dissipation, avoid places with insufficient ventilation. Do not block the ventilation holes at the top and bottom of the unit. Do not place the unit on a carpet because this will block the ventilation holes.
- Install unit in a horizontal position.
- Avoid locations subject to strong vibration.
- Do not place the TV/VCR near strong magnetic fields.
- Avoid moving TV/VCR to locations where temperature differences are extreme.

## Avoid the Hazards of Electrical Shock and Fire

- Do not handle the power cord with wet hands.
- Do not pull on the power cord when disconnecting it from an AC wall outlet. Grasp it by the plug.
- If, by accident, water is spilled on your unit, unplug the power cord immediately and take the unit to Sears Service Center for servicing.
- Do not put your fingers or objects into the TV/VCR cassette holder.
- Do not place anything directly on top of the unit.

## CAUTION

Moisture condensation may occur inside the unit when it is moved from a cold place to a warm place, or after heating a cold room or under conditions of high humidity. If a tape is played in a TV/VCR which has moisture, it may damage the tape and TV/VCR. Therefore when you suspect that condensation has occurred inside the unit, or if "DEW" appears on the screen, turn the POWER button ON and allow at least 2 hours for the unit to dry out.

## IMPORTANT COPYRIGHT INFORMATION

Unauthorized recording or use of broadcast television programming, video tape, film or other copyrighted material may violate applicable copyright laws. Sears assumes no responsibility for unauthorized duplication, use, or other acts which infringe upon the rights of copyright owners.

## FCC WARNING

This equipment may generate or use radio frequency energy. Changes or modifications to this equipment may cause harmful interference unless the modifications are expressly approved in the instruction manual. Do not operate this equipment if an unauthorized change or modification is made.

This equipment has been tested and found to comply with the limits for a Class B digital device, pursuant to Part 15 of the FCC Rules. These limits are designed to provide reasonable protection against harmful interference in a residential installation. This equipment generates, uses, and can radiate radio frequency energy and, if not installed and used in accordance with the instructions, may cause harmful interference to radio communications.

However, there is no guarantee that interference will not occur in a particular installation. If this equipment does cause harmful interference to radio or television reception, which can be determined by turning the equipment off and on, the user is encouraged to try to correct the interference by one or more of the following measures:

- 1) Reorient or relocate the receiving antenna.
- 2) Increase the separation between the equipment and receiver.
- 3) Connect the equipment into an outlet on a circuit different from that to which the receiver is connected.
- 4) Consult the dealer or an experienced radio/TV technician for help.

## A NOTE ABOUT RECYCLING

This product's packaging materials are recyclable and can be reused. Please dispose of any materials in accordance with your local recycling regulations.

Batteries should never be thrown away or incinerated but disposed of in accordance with your local regulations concerning chemical wastes.

## FEATURES

---

- **Infrared remote control**
- **Bilingual on-screen menu display selectable in English or Spanish**
- **Real time counter–**

This shows the elapsed recording or playback time in hours, minutes, and seconds. The "-" indication will appear when the tape is rewound further than the tape counter position "0:00:00".
- **181 channel capability PLL frequency synthesizer tuner with direct station call–**

A converter may be necessary to view scrambled cable channels.
- **Auto Clock Setting–**

Allows you to set the clock function from a PBS broadcast station.
- **Game mode–**

Automatically sets external input mode and allows TV/VCR display to be suitable for use with TV games.
- **Auto power on and off system–**

Automatically turns on the TV/VCR when you insert the cassette, turns off after auto-rewind, and ejects when the beginning of the tape is reached.
- **Auto rewind when the end of a tape is reached–**

This function doesn't occur when using timer recording.
- **Three different playback tape speeds : SP/LP/SLP**
- **Two different recording tape speeds : SP/SLP**
- **2 Step picture search operation–**

You can view a video program at high speed or super high speed in either a forward or reverse direction in LP and SLP mode. High speed only in SP mode.
- **Dew sensor–**

Indicates that moisture condensation may have occurred inside the TV/VCR.
- **Zero Return–**

The tape returns to counter of 0:00:00 by rewinding or fast-forwarding.
- **Still–**

"Freeze" the picture at any time, for close viewing of a particular scene. Only tapes recorded in SLP mode will show a fairly clear picture.
- **Digital Auto Tracking (DTR)–**

Automatically adjusts the tracking for each tape you play.
- **Rental play mode–**

Improves playback picture quality from worn tapes, such as rental tapes.
- **Auto repeat–**

Allows you to repeat a tape indefinitely without pressing the PLAY button.
- **Time search–**

Let you set the TV/VCR to advance the tape by entering the desired playback time you want to skip.
- **OTR (One Touch Recording)–**

Instant timed recording from 30 to 480 minutes is possible at the push of the REC/OTR button.
- **1 Year, 8 events (including Daily and Weekly Timer Recording)–**

The built-in timer allows you to record up to 8 programs at different times on different channels up to 1 year in advance. The Daily timer allows recordings to be made of daily broadcasts, and the Weekly timer allows recording to be made once a week up to the end of the tape.
- **Auto return–**

After timer recording is finished, the TV/VCR can return to the beginning of the recording.
- **Wake up/Sleep timer–**

Allows you to have the TV/VCR automatically turn on or off at a desired time.
- **Timer Program Extension–**

Allows you to shift the time schedule for automatic timer recording.
- **Dual power–**

Allows you to power TV/VCR with household AC or with car battery.

# VIDEO CASSETTE

This TV/VCR will operate with any cassette that has the **VHS** mark. For best results, we recommend the use of high-quality tapes. Do not use poor quality or damaged tapes.

### PREPARATION

- Avoid moisture. Moisture condensation may occur inside the unit when it is moved from a cold place to a warm place, or after heating a cold room or under conditions of high humidity. If a tape is played in a TV/VCR which has moisture, it may damage the tape and TV/VCR. Therefore when you suspect that condensation has occurred inside the unit, turn the POWER button ON and allow at least 2 hours for the unit to dry out.
- Avoid extreme heat, high humidity and magnetic fields.
- Do not tamper with the cassette mechanism.
- Do not touch the tape with your fingers.

Position cassette with the view-window facing up, as pictured below. Insert cassette into cassette slot by pushing in gently, but continuously, on the center of the cassette back until cassette is drawn into the TV/VCR.

Once cassette is fully inserted, the TV/VCR will automatically turn on.

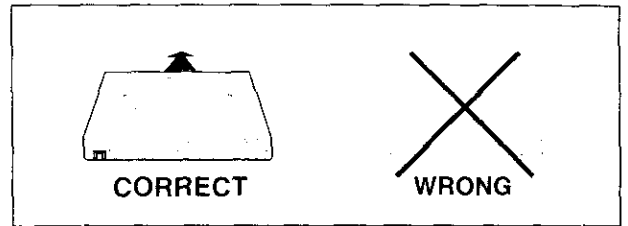

### TAPES

You may choose to record at two different tape speeds:

- **SP-Standard Play**
- **SLP- Super Long Play**

The table below shows the maximum recording/playback time using T60, T120 or T160 tapes in each mode.

Tape Speed	Recording/Playback Time			
	Type of tape	T60	T120	T160
SP mode		1 hour	2 hours	2-2/3 hours
SLP mode		3 hours	6 hours	8 hours

**NOTE:** You can play back a tape recorded in LP (Long Play) mode.

- 1) With the TV/VCR in the Stop mode, press the EJECT button on the remote control, or press the STOP/EJECT button on the TV/VCR. The cassette will eject.
- 2) Pull the cassette out of the cassette compartment.
- 3) Store the cassette in its case as shown.

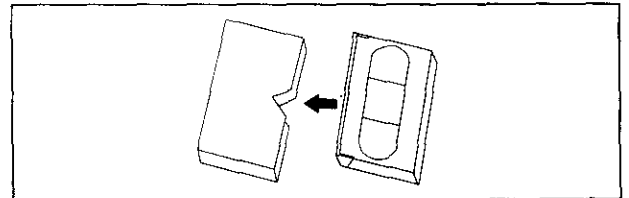

### TRADE PREVENTION

You can prevent accidental erasing of recording by breaking off the tab on the back edge of the cassette.

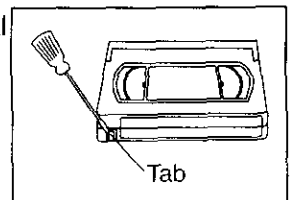

If you decide to record on the tape again, cover the hole with plastic tape.

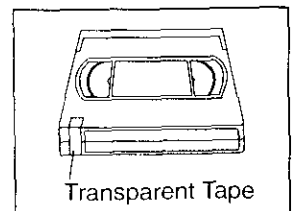



# OPERATING CONTROLS AND FUNCTIONS

## NOTES:

- We do not recommend that you use a "universal" remote control to operate this TV/VCR. Not all of the functions may work. Call the manufacturer of the universal remote control, not Sears, if you have problems with it.
- Depending on your antenna system, you may need other connectors in addition to the coaxial cable supplied with this unit. See Antenna/Cable Connections section of this manual.

## - TV/VCR FRONT PANEL -

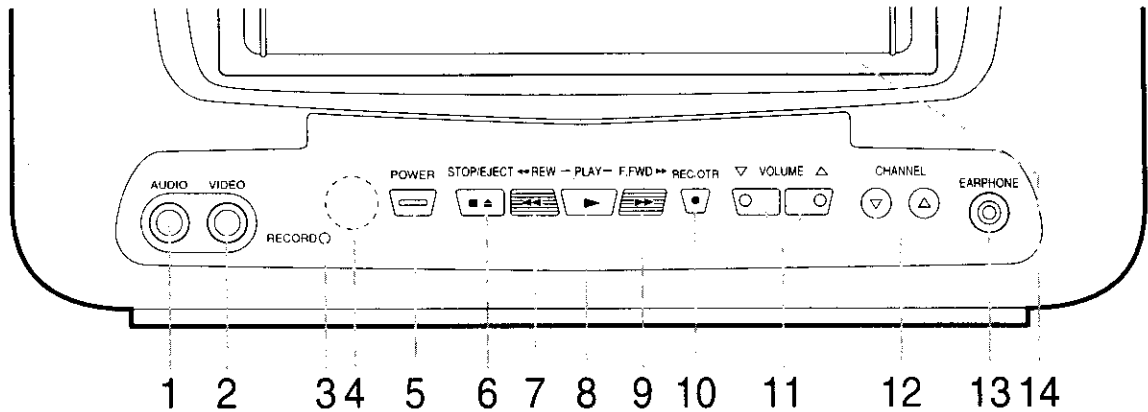

## - REMOTE CONTROL -

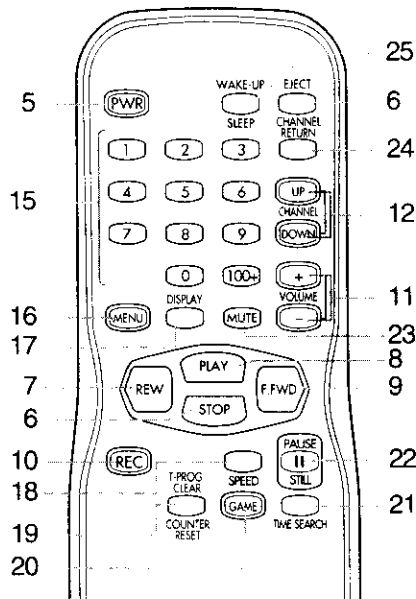

- 1 AUDIO input jack-**  
Connect to the audio output jack of your audio equipment, video camera or another VCR.
- 2 VIDEO input jack-**  
Connect to the video output jack of your video camera or another VCR.
- 3 RECORD indicator-**  
Flashes during recording.  
Lights up in the Stand-by mode for Timer Recording.
- 4 Remote Sensor Window-**  
Receives the infrared signals from the remote control.

- 5 PWR(POWER) button-**  
Press to turn TV/VCR on and off. Press to activate timer recording.
- 6 STOP button-**  
Press to stop the tape motion.  
**EJECT button-**  
Press in the Stop mode to remove tape from TV/VCR.  
Select the setting modes from the on-screen menu. Press to enter digits when setting program. (For example: Setting clock or timer program)
- 7 REW button-**  
Press to rewind the tape, or to view the picture rapidly in reverse during the PLAY mode.  
Press to select a mode from a particular menu. (For example: Language or user's set up)
- 8 PLAY button-**  
Press to start the PLAY mode.  
Select the setting modes from the on-screen menu. Press to enter digits when setting program. (For example: Setting clock or timer program)
- 9 F.FWD button-**  
Press to rapidly advance the tape, or to view the picture rapidly in forward during playback mode.  
When setting program (For example: Setting clock or timer program), press to determine your selection and proceed to the next step you want to input. Press to determine setting modes from on-screen menu. Press to select a mode from a particular menu. (For example: Language or user's set up)

- 10 REC(ORD) button-**  
Press for manual recording.
- OTR button-** Activates One Touch Recording. (Only on the TV/VCR)
- 11 VOLUME +/- (UP/DOWN) buttons-**  
Adjust the volume level.
- 12 CHANNEL UP/DOWN buttons-**  
Press to select the desired channels for viewing or recording.
- TRACKING function-** Press to minimize video 'noise' (lines or dots on screen) during playback mode.
- 13 EARPHONE jack-**  
Connects to earphones (not supplied) for personal listening. The size of jack is 1/8" monaural (3.5mm).
- 14 Cassette slot-**  
Insert the cassette here.
- 15 Number buttons-**  
Press to select desired channels for viewing or recording. To select channels from 1 to 9, first press the 0 button and then 1 to 9.
- 100+ button-** When selecting cable channels which are higher than 99, press this button first, then press the last two digits. (To select channel 125, first press the "100+" button then press "2" and "5").
- 16 MENU button-**  
Press to display the main menu on the TV screen.
- 17 DISPLAY button-**  
Display the counter or the current channel number and current time on the TV screen.
- 18 SPEED button-**  
Press to choose the desired recording speed: SP/SLP.
- 19 T-PROG. CLEAR button-**  
Press to cancel a timer program setting. (See page 27.)
- COUNTER RESET button-** Press to reset counter to 0:00:00.
- 20 GAME button-**  
Sets the game mode and external input mode at the same time.
- 21 TIME SEARCH button-**  
Press to activate Time Search mode.
- 22 PAUSE/STILL button-**  
Press to temporarily stop the tape during the recording or to view a still picture during playback.
- 23 MUTE button-**  
Mutes the sound. Press it again to resume sound.
- 24 CHANNEL RETURN button-**  
Press to go back to the previously viewed channel. For example, pressing this button once will change channel display from 3 (present channel) to 10 (previously viewed channel), and pressing it a second time will return from 10 to 3.
- 25 WAKE UP/SLEEP button-**  
Sets the Wake up or Sleep Timer.
- 26 ANT. terminal-**  
Connect to an antenna or cable system.
- 27 DC 13.2V jack-**  
Connect to the Car Adapter Cord.
- 28 AC 120V jack-**  
Connect to the AC cord.

**- REAR VIEW -**

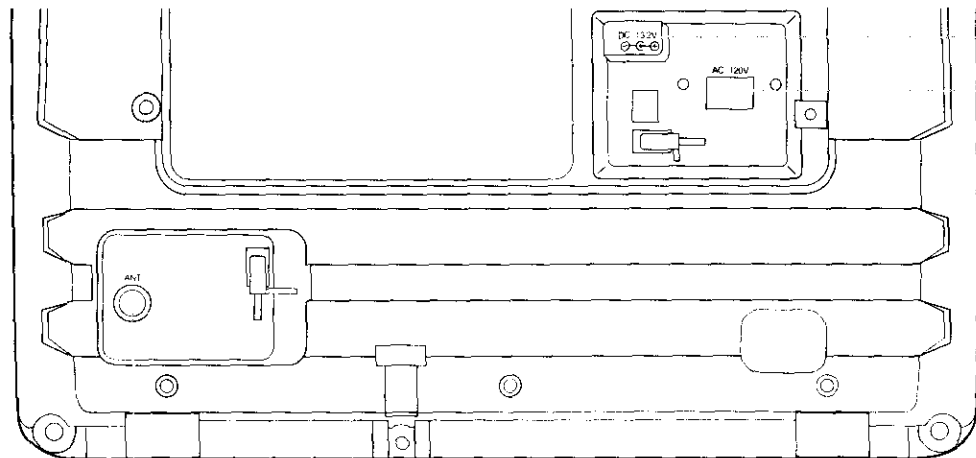

26

# PREPARATION FOR USE

## Antenna/Cable Connections

### VHF/UHF COMBINED ANTENNA

The VHF/UHF Dipole Antenna (supplied) is detachable. Insert the stem of the antenna into the hole on the upper-back portion of the TV/VCR.

Connect the VHF/UHF Dipole Antenna or VHF/UHF Combination Antenna to the Antenna terminal of the TV/VCR as shown in the diagram below.

For the best reception, fully extend the VHF/UHF Dipole Antenna and make the necessary adjustments. (Avoid touching the top section when adjusting.)

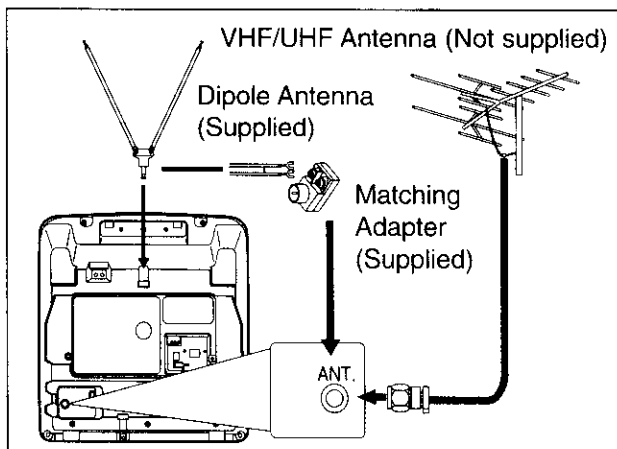

#### NOTE:

The connection of an indoor antenna may not always give acceptable TV reception.

### VHF/UHF OUTDOOR ANTENNAS

In some areas it will be necessary to use an outdoor antenna. If you have separate UHF and VHF antennas, you will need a VHF/UHF combiner (not supplied) to make the connection to the Antenna terminal of the TV/VCR. If you have a VHF/UHF 75 ohm combination antenna, you can make the connection to the Antenna terminal of the TV/VCR without needing a VHF/UHF combiner.

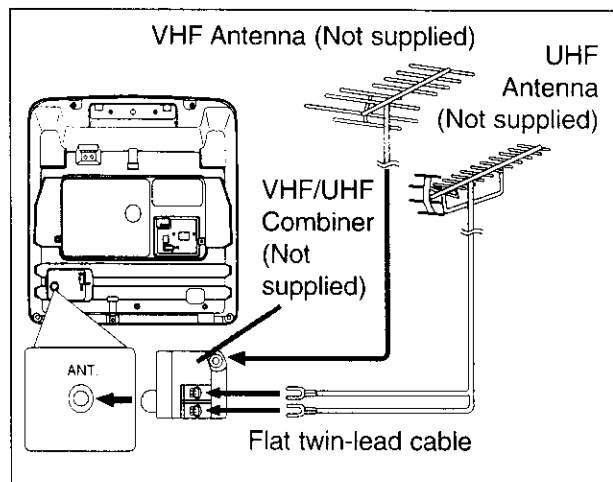

### CABLE WITHOUT CONVERTER/DESCRAMBLER BOX

If your cable system does not require a converter box, simply connect the 75 ohm coaxial cable (not supplied) from the cable system wall outlet to the Antenna terminal of your TV/VCR.

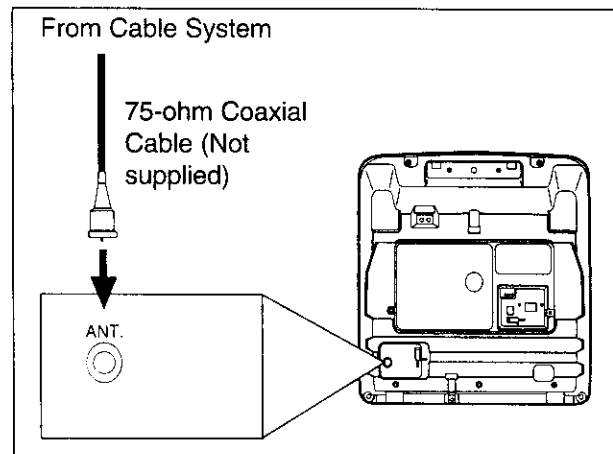

#### Note to CATV system installer:

This reminder is provided to call the CATV system installer's attention to Article 820-40 of the NEC that provides guidelines for proper grounding and, in particular, specifies that the cable ground shall be connected to the grounding system of the building as close to the point of cable entry as practical.

## CABLE WITH CONVERTER/ DESCRAMBLER BOX OR SATELLITE BOX

You cable system may require a converter box, or if you use a satellite system, you will need a satellite box. In each case, you must connect a 75 ohm coaxial cable (not supplied) from the cable system wall outlet to the box, and another 75 ohm coaxial cable from the box to the Antenna terminal of your TV/VCR. See below.

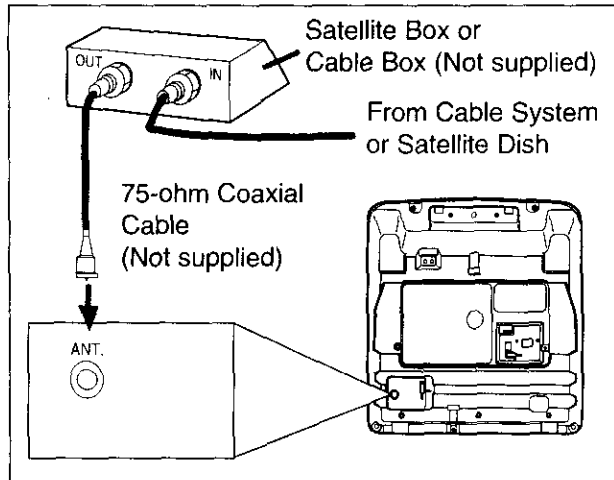

## TO RECORD A SCRAMBLED/UNSCRAMBLED CHANNEL

1. Set the TV/VCR channel selector to the output channel(3 or 4) of the cable or satellite box.
2. Select the channel to be recorded or viewed on the cable or satellite box.

## NOTE:

- Be sure your vehicle has a 13.2-volt, negative-ground electrical system.
- Be sure you use only the supplied car adapter cord. Using another cord could damage the TV/VCR.
- Be sure the socket is free of ashes and any other debris.
- Be sure to push the car adapter cord's plug completely into the cigarette-lighter socket.
- Always unplug the car battery from the cigarette-lighter socket before you unplug it from the TV/VCR.
- You must disconnect the car adapter cord from the TV/VCR before you can use the AC power.
- Be sure to replace the fuse with only the same type, 5A, 250V.

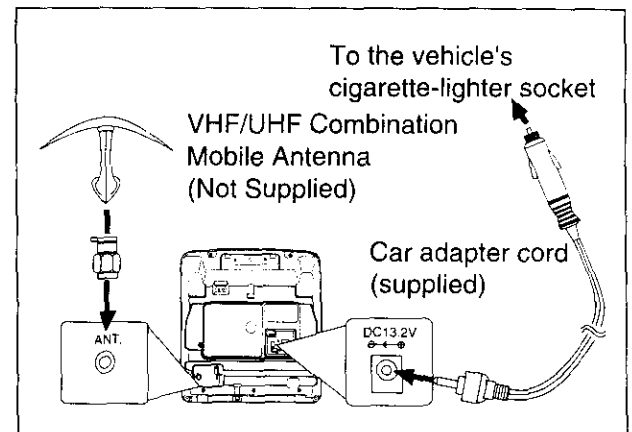

## Mobile Connection

**WARNING:** Never watch the TV/VCR while driving.

**CAUTION:** If you use the TV/VCR with the vehicle's engine off, recharge the vehicle's battery about every 4 hours to prevent it from running down. After you finish using the TV/VCR be sure you unplug the car adapter cord from the cigarette-lighter socket.

- 1) The supplied indoor antenna is adequate when your vehicle is stationary. For best reception on the road, use a high-quality VHF/UHF mobile TV antenna.
- 2) Attach the car adapter cord to the DC13.2V connector on the back of the TV/VCR. Then, connect the other end to your vehicle's cigarette-lighter socket.

---

## Installing the Batteries

- 1) Open the battery compartment cover by pressing the cover on the remote unit in the direction of the arrow.
- 2) Insert 2 "AA" penlight batteries into the battery compartment in the direction indicated by the polarity (+/-) markings.
- 3) Replace the cover.

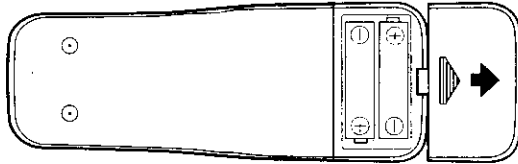

## External Input Mode

When using an external input signal (another VCR or video camera), connect the player's audio/video output cables to the AUDIO IN/VIDEO IN jacks of your TV/VCR. Then press the CHANNEL UP or DOWN button until "AUX" appears on the screen.

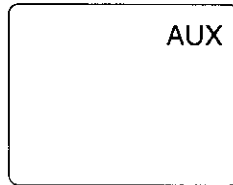

# SET UP FOR USE

## CHANNEL MEMORY PROGRAMMING

Use this feature to program the TV/VCR tuner to scan and memorize all the channels you receive in your area.

You can use this feature to memorize cable channels only if your cable system connects directly from its wall outlet to the Antenna terminal of your TV/VCR. You cannot use this feature when the TV/VCR is connected to a cable or satellite box.

### Channel Set Up for the First Time

1 Plug in the TV/VCR power cord

Attach the smaller end of the supplied AC cord to the AC 120V connector on the back of the TV/VCR. Then, plug the other end into a standard AC outlet. Press the POWER button to turn on the TV/VCR.



#### NOTE:

- The car adapter cord must not be connected to the TV/VCR when you use household AC power.
- If some digits appear in the corner of the screen, press the POWER button to turn off the set, and then press the POWER button again to turn the set back on. This will reset the TV back to customer mode. Do not unplug the power cord during this reset.

2 Turn on the TV/VCR

Press the POWER button to turn on the TV/VCR.

3 Select "ENGLISH" or "ESPAÑOL"

Select "ENGLISH" or "ESPAÑOL" = Spanish using the F.FWD or REW button. "[ ]" indicates the selected language.

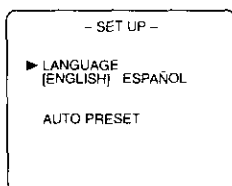

4 Begin auto preset

Press the PLAY or STOP button to point to "AUTO PRESET".

Then press the F.FWD button. The tuner scans and memorizes all active channels in your area.



#### NOTE:

- The TV/VCR distinguishes between standard TV channels and cable channels.
- If you want to play or record a video tape BEFORE presetting the tuner, you must press the MENU button on the remote control. To preset the tuner again, see "CHANNEL SET UP AGAIN" on page 15.
- If reception conditions are poor, the TV/VCR may recognize TV channels as CATV channels or viceversa. If this occurs, try running the AUTO PRESET again when reception conditions are better.

5 After scanning

The tuner stops on the lowest memorized channel. If you want to recall the selected channels, you can select the desired channel directly with the remote control number buttons or CHANNEL UP or DOWN.

### Deleting (or Adding) Channel

The channels you no longer receive or seldom watch can be deleted from the memory. (Of course, you can add the deleted channel into the memory again.)

1 Select "CHANNEL SET UP"

Press the MENU button on the remote control. Press the PLAY or STOP button to point to "CHANNEL SET UP".

Then, press the F.FWD button.

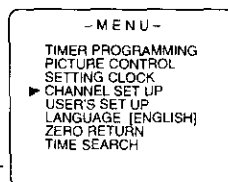

2 Select "ADD/DELETE CH"

Press the PLAY or STOP button to point to "ADD/DELETE CH". Press the F.FWD button.

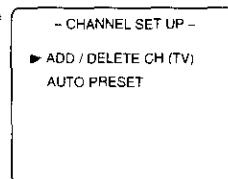

3 Enter the desired channel number

Press the PLAY or STOP button until your desired channel number appears. (You can also use the number buttons or the CHANNEL UP/DOWN button to enter it.)

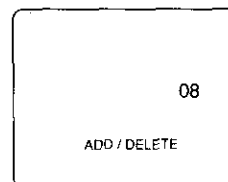

4 Delete (or add) it from (or into) memory

Press the F.FWD or REW button. The channel number changes to **light red**.

The channel is deleted from memory.

If you press the F.FWD or REW button again, the channel number changes to **light blue**. The channel is added to memory again.

To delete another channel, repeat steps 3 and 4.

Press the MENU button on the remote control to return to TV mode.

**NOTE:** Press the CHANNEL UP or DOWN button to confirm that channel(s) have been deleted or added.

## Channel Set Up Again

### Make sure:

- Press the POWER button to turn on the TV/VCR.

#### 1 Select "CHANNEL SET UP"

Press the MENU button on the remote control.

Press the PLAY or STOP button to point to "CHANNEL SET UP".

Then, press the F.FWD button.

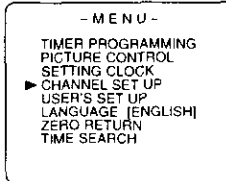

#### 2 Begin auto preset

Press the PLAY or STOP button to point to "AUTO PRESET".

Then, press the F.FWD button. The tuner scans and memorizes all the active channels in your area.

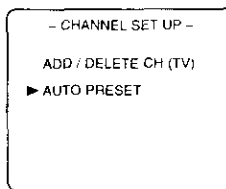

#### 3 After scanning

The tuner stops on the lowest memorized channel.

## Selecting the Language

### Make sure:

- Press the POWER button to turn on the TV/VCR.

**NOTE:** This feature **only** changes the on-screen menu language. It **does not** change the language you hear spoken on the TV.

#### 1 Select "LANGUAGE"

Press the MENU button on the remote control.

Press the PLAY or STOP button to point to "LANGUAGE".

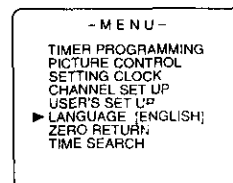

#### 2 Select "ENGLISH" or "ESPAÑOL"

Select "ENGLISH" or "ESPAÑOL" = Spanish using the F.FWD or REW button.

#### 3 Exit the Language mode

Press the MENU button on the remote control to return to TV mode.

**NOTE:** If for some reason the menu is in Spanish, press the MENU button on the remote control, press the PLAY button to point to "IDIOMA [ESPAÑOL]", then press the F.FWD button, then press the MENU button on the remote control.

## Daylight-Saving Time

If you select this feature, the TV/VCR's clock immediately advances one hour in April and reverses one hour in October.

- **First Sunday of April** : At 2 AM the clock immediately changes to 3 AM. Any timer programming you have set to occur between 2 AM and 3 AM will not record.
- **Last Sunday of October** : At 2 AM the clock immediately changes to 1 AM.

### Make sure:

- Press the POWER button to turn on the TV/VCR.

#### 1 Select "SETTING CLOCK"

Press the MENU button on the remote control.

Press the PLAY or STOP button to point to "SETTING CLOCK".

Then, press the F.FWD button.

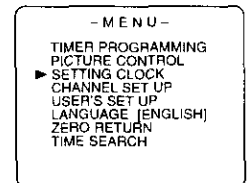

#### 2 Set "D.S.T." (Daylight-Saving Time) to [ON]

Press the PLAY or STOP button to point to "D.S.T.".

Then, press the F.FWD or REW button until [ON] appears.

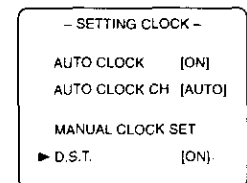

#### 3 Exit the Daylight-Saving Time mode

Press the MENU button on the remote control to return to TV mode.

### TO CANCEL THE DAYLIGHT-SAVING TIME MODE

Repeat steps [1] to [2], select [OFF] using the F.FWD or REW button.

## Clock Set Up (Auto / Manual)

Set the clock accurately for proper automatic timer recording. If a Public Broadcasting Station (PBS) is available in your area, follow "AUTO CLOCK SETTING". If there isn't one, then follow "MANUAL CLOCK SETTING".

### AUTO CLOCK SETTING

You can have the TV/VCR set the clock time and date automatically via the Extended Data Service (XDS) of your local Public Broadcasting Station (PBS) channel.

#### Make sure:

- TV/VCR power must be turned on.
- Antenna connections are correct.
- Cable converter box is turned on if your TV/VCR is connected to one.
- The channel is properly set in advance. (See page 15.)

#### NOTES:

- Auto clock setting only needs to be set once. But it can be done again if the clock's time has become incorrect for some reason.
- If the TV/VCR is connected directly to a cable converter box or satellite box, the local PBS station must be selected on the cable box itself. The TV/VCR must be set to the output channel of the cable or satellite box (usually channel 3 or 4), to be able to set up or correct the clock automatically.
- The TV/VCR cannot control the channels of the cable or satellite box.
- You cannot use AUTO CLOCK and D.S.T. setting with the car adapter cord.

### 1 Select "SETTING CLOCK"

Press the MENU button on the remote control.

Press the PLAY or STOP button to point to "SETTING CLOCK".

Then, press the F.FWD button.



### 2 Set "AUTO CLOCK" to [ON]

Press the F.FWD or REW button repeatedly until [ON] appears.

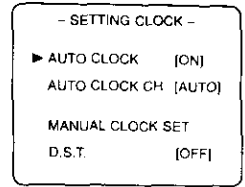

### 3 Enter the channel number for the PBS station

Press the PLAY or STOP button to point to "AUTO CLOCK CH".

Then press the F.FWD or REW button until the channel number for your local PBS station appears.

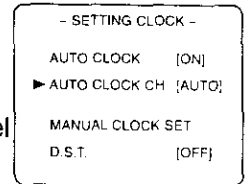

Leave menu set to [AUTO] if you do not know the local PBS channel number. The TV/VCR will automatically search all available channels and select it.

### 4 Exit the Auto Clock Setting

Press the MENU button on the remote control to return to TV mode.

### 5 Turn off the TV/VCR

Turn the TV/VCR off. The Auto Clock functions automatically when the TV/VCR is off.

#### If you choose [AUTO]:

- The TV/VCR must scan each channel for a couple of seconds to determine if it is transmitting an XDS signal.
- If the time automatically set by [AUTO] is incorrect, it may have accessed the XDS signal from a PBS channel outside your time zone. In this case, you must manually enter the correct PBS channel.
- If [AUTO] cannot locate a XDS signal, you must set the clock manually.



## MANUAL CLOCK SETTING

### Make sure:

- TV/VCR power must be turned on.

In the example below, the clock is to be set to:

DATE May 1st, 2000

SETTING TIME 5:40PM

### 1 Select "SETTING CLOCK"

Press the MENU button on the remote control.

Press the PLAY or STOP button to point to "SETTING CLOCK".

Then, press the F.FWD button.

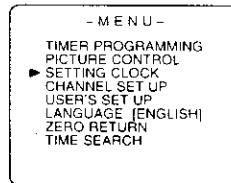

### 2 Press the PLAY or STOP button

until your desired hour appears.

(Example: 5, PM)

Then, press the F.FWD button.

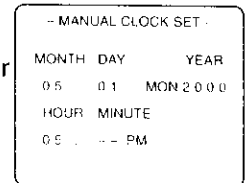

### 2 Select "MANUAL CLOCK SET"

Press the PLAY or STOP button to point to "MANUAL CLOCK SET".

Then, press the F.FWD button.

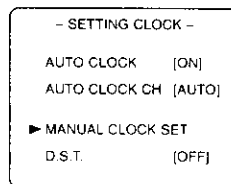

### 3 Select the minute

Press the PLAY or STOP button until the desired minute appears.

(Example: 40)

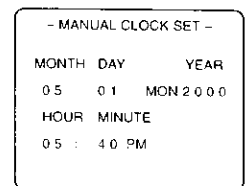

### 3 Select the month

Press the PLAY or STOP button until your desired month appears.

(Example: May → 05)

Then, press the F.FWD button.

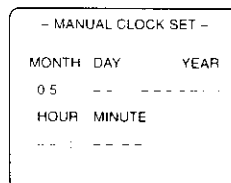

### 4 Start the clock

Press the MENU button on the remote control.

Although seconds are not displayed, they begin counting from 00 when you press the MENU button on the remote control. Use this feature to synchronize the clock with the correct time.

**NOTE:** When unplugging the AC cord or if there is a power failure for more than 30 seconds, you may have to reset the clock.

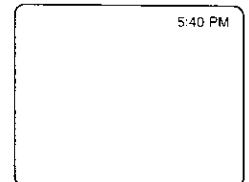

### 4 Select the day

Press the PLAY or STOP button until your desired day appears.

(Example: 1st → 01)

Then, press the F.FWD button.

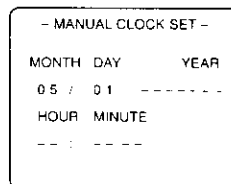

### TO CHANGE CLOCK SETTING

If you want to change the clock,

- 1) Follow steps [1] and [2].
- 2) Select where you want to change using the F.FWD or REW button.
- 3) Enter correct numbers using the PLAY or STOP button.
- 4) Press the MENU button on the remote control to start the clock.

### 5 Select the year

Press the PLAY or STOP button until your desired year appears.

(Example: 2000)

Then, press the F.FWD button.

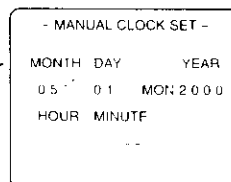

### NOTE:

If there is no local PBS station in your area or on your cable system, select "AUTO CLOCK" and press the F.FWD or REW button to turn [OFF] this function. Then you can manually adjust the clock.

## ON SCREEN DISPLAY

---

To view the Counter or Clock/Channel information, press the DISPLAY button once for Counter mode and twice for Clock/Channel mode. Press the DISPLAY button to clear the Counter or Clock/Channel information.

## SPECIAL FEATURES

---

### Degaussing

Magnetism from nearby appliances might affect the color of the TV picture.

If this happens, move this unit away from the appliance. If the color is still not correct, disconnect the power cord from the AC outlet, then reconnect it after 30 minutes.

### Real Time Tape Counter

This shows the elapsed recording or playback time in hours, minutes, and seconds. (The displayed time will not change on a blank tape or blank portions on the tape.)

The “-” indication will appear when the tape has rewound further than "0:00:00" on the tape counter.

### Auto Rewind-Eject

- When the end of a tape is reached during recording, playback, or fast-forward, the tape will automatically rewind to the beginning. After rewinding finishes, the TV/VCR will eject the tape and turn itself off.
- This function will operate when Repeat Play is turned off.
- The tape will not auto-rewind during timer recording or One Touch Recording.

# TV OPERATION

## Watching a TV Program

1 Turn on the TV/VCR

Press the POWER button to turn on the TV/VCR.

2 Select the channel number

Press the CHANNEL UP or DOWN button to select your desired channel number or press the number buttons on the remote control.

Remember: If the TV/VCR is connected to a cable box or satellite box, the TV/VCR must be on CH3 or CH4, then the channel to be viewed must be selected on the cable box or satellite box.

3 Adjust sound

Press the VOLUME +/- (UP/DOWN) button to adjust the volume.

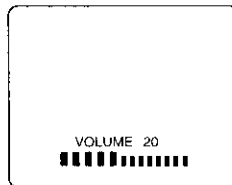

## Game Mode

This function enables you to decrease the TV screen contrast, making it better for Video games.

**NOTE:** This function cannot be set during recording.

Press the GAME button on the remote control. "GAME" appears on the screen.



When you press the GAME button;

- The TV/VCR comes on automatically if it is off.
- The TV/VCR will be in external input mode automatically.

TO CANCEL THE GAME MODE

Press the GAME button or CHANNEL UP or DOWN button on the remote control.

## Picture Control

The TV/VCR's picture controls – **BRIGHT, CONTRAST, COLOR, TINT** and **SHARPNESS** – are preset at the factory. Although they are usually the best, you may need to make some further adjustments for a natural looking image.

**NOTE:**

- Procedures must be performed within 5 seconds or the Picture Control mode will be cancelled.
- When setting the Picture Control, the Game mode will be cancelled.

**Make sure:**

- TV/VCR power must be turned on.

1 Select "PICTURE CONTROL"

Press the MENU button on the remote control.

Press the PLAY or STOP button to point to "PICTURE CONTROL".

Then, press the F.FWD button.

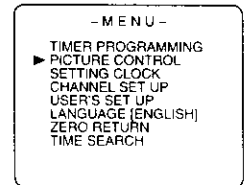

2 Select item you want to adjust

Press the PLAY or STOP button until desired control is displayed.

BRIGHT  
CONTRAST  
COLOR  
TINT  
SHARPNESS

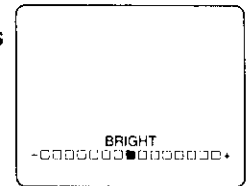

3 Adjust the picture control

Press the F.FWD or REW button to adjust to your desired level.

	REW	F.FWD
<b>BRIGHT</b>	to decrease brightness	to increase brightness
<b>CONTRAST</b>	to decrease contrast	to increase contrast
<b>COLOR</b>	to pale	to brilliant
<b>TINT</b>	to purple	to green
<b>SHARPNESS</b>	to soft	to clear

- If there is a power failure of any kind, the unit will retain its memory for this feature.

# PLAYBACK

## Normal Playback

### Make sure:

- TV/VCR power must be turned on.

Insert a prerecorded tape.

If the erase-protection tab has been removed, the TV/VCR will start playback automatically.

Go to play mode.

Press the PLAY button.

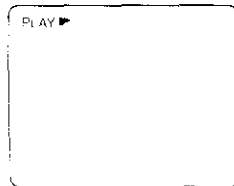

Playback is over.

Press the STOP button when playback is completed.

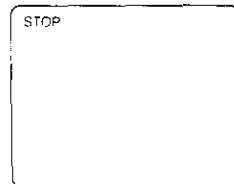

- Tracking adjustment will be set automatically (Digital Tracking function) when you start playback.
- However when playing prerecorded tapes or tapes recorded on units other than your own, noise lines (black and white streaks) may appear on the playback picture. If this occurs, you can adjust the tracking control manually by pressing the CHANNEL UP or DOWN button until the streaks disappear. To return to the DTR function, stop the tape once and start playback again.

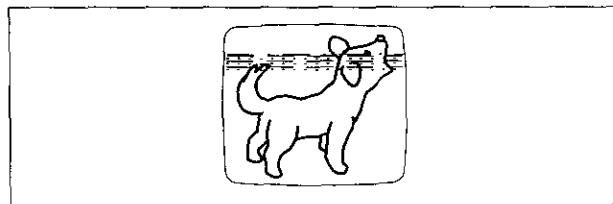

This feature is very useful in finding or skipping over a particular scene on a tape. In this mode, the sound will be muted.

- 1) You may view a video tape at a high speed in either a forward or reverse direction by pressing the F.FWD or REW button. (in the SP / LP / SLP modes).

- 2) Press it again and the TV/VCR will now search in super high speed (in the LP / SLP modes only).

**NOTE:** Tapes recorded in the SP or LP mode will display a noise bar on the TV screen and the picture may appear in Black and White.

This is normal.

- 3) Press the PLAY button to return to normal speed.



## Still Picture

You can view a still picture on the TV (Still mode) screen during playback. Press the PAUSE/STILL button during playback. Tapes recorded in the SLP mode will show the least amount of lines. Press the PLAY button to return to playback.

### NOTE:

- Usually there will be video "noise" lines (black and white streaks or dots) on the screen. This is normal.  
If the tape was originally recorded in SP or LP mode, the still picture will be black and white in addition to the "noise" lines.  
**This is not a fault of the machine, but merely a by-product of the technology involved in producing a TV/VCR with 2 video heads.**
- If it is left in the Pause mode for more than five minutes, the TV/VCR will automatically switch to the Stop mode.



## Noise line Reduction (in the Still mode)

This feature allows you to reposition or reduce the noise lines of a still picture.

Press the PAUSE/STILL button so that the noise lines change position on the screen and you can see the picture in its entirety without distracting noise lines.

**NOTE:** This feature can be activated ONLY when viewing a tape recorded in the SLP mode. If the tape was originally recorded in the SP or LP mode, the still picture may appear in black and white in addition to the "noise bars". This is normal.



In the Pause/Still mode only, when the picture begins to vibrate vertically, stabilize the picture by pressing the CHANNEL UP or DOWN button.

**NOTE:** If there are video noise lines on the screen, reposition or reduce them. Refer to "Noise line Reduction".

# SPECIAL PLAYBACK

## Make sure:

- TV/VCR power must be turned on.
- Insert a prerecorded tape.
- Before playback, follow steps below.

## Rental Playback

This function enables you to improve the picture quality when playing back worn cassettes such as rented tapes.

### 1 Select USER'S SET UP

Press the MENU button on the remote control.

Press the PLAY or STOP button to point to "USER'S SET UP".

Then, press the F.FWD button.

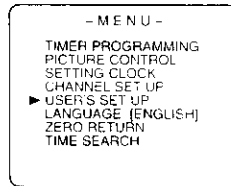

### 2 Set RENTAL mode

Press the PLAY or STOP button to point to "RENTAL".  
Press the F.FWD or REW button until [ON] appears.



### 3 Exit the RENTAL setting

Press the MENU button on the remote control to return to the TV mode.

### 4 Start playback

Press the PLAY button to start playback.  
"RENTAL PLAY ▶" appears.

- Once you select the Rental mode, it stays in effect even after you turn off the TV/VCR.

## TO CANCEL THE RENTAL MODE

Repeat steps [1] and [2], select [OFF] using the F.FWD or REW button on the remote control.  
Press the MENU button on the remote control to return to TV mode.

**If there is a power failure of any kind, the unit will retain its memory for this feature.**

## Auto Repeat Playback

The TV/VCR allows you to repeat a tape indefinitely without using the PLAY button. There are two selections for Repeat Playback.

**ALL REPEAT:** Repeat playback from the beginning to the end of the tape.

**BLANK REPEAT:** Repeat playback from the beginning to a blank part, which is blank for more than 10 seconds.

Press the MENU button on the remote control.

Press the PLAY or STOP button to point to "USER'S SET UP".

Then, press the F.FWD button.

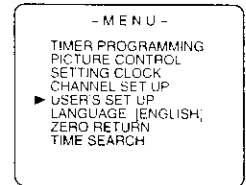

Press the PLAY or STOP button to point to "REPEAT PLAY".

Press the F.FWD or REW button repeatedly until your desired selection [ALL] or [BLANK] appears.

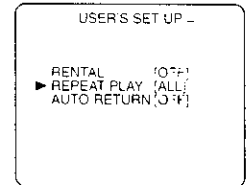

### 4 Start the Repeat Playback

Press the MENU button on the remote control to return to the TV mode.

### 4 Start playback

Press the PLAY button to start the Repeat Play.  
"REPEAT PLAY ▶" appears.

- Once you select the Repeat Play mode, it stays in effect even after you turn off the TV/VCR.
- If the Rental mode is set [ON], the "RENTAL PLAY ▶" display has priority.

Repeat steps [1] and [2], select [OFF] using the F.FWD or REW button on the remote control.  
Press the MENU button on the remote control to return to TV mode.

**If there is a power failure of any kind, the unit will retain its memory for this feature.**

# SEARCH

## Make sure:

- TV/VCR power must be turned on.
- Insert a tape.

## Zero Return

Use this function to mark a point on the tape that you wish to quickly return to later.

**NOTE:** You cannot mark a blank spot on the tape.

- 1 Stop a tape at your desired point.

Rewind or fast forward the tape to the beginning point you want to review.

- 2 Reset the counter to 0:00:00.

Press the COUNTER RESET button repeatedly.

- 3 Begin recording or playback.

Press the REC(ORD) or PLAY button.

Press the STOP button when recording or playback is completed.

- 4 To return to marked point.

Press the MENU button on the remote control.

Press the PLAY or STOP button to point to "ZERO RETURN".

Then, press the F.FWD button.

The counter will appear on the TV screen.

The tape will automatically stop when the counter returns to 0:00:00.

Press the PLAY button to view tape.



## Time Search

This function advances the tape to a specific position when you enter the amount of playback time you want to skip.

### NOTE:

- Time Search can be set up to a maximum of 9 hours 50 minutes (9:50) by 10 minutes at a time.
- This function will not operate in recording mode.

- This function will not operate without a tape in the TV/VCR.

### Time Search Example

To skip a program that is 2 hours and 50 minutes of tape length, in either direction, from the present tape position.

- 1 Insert a tape.

- 2 Select "TIME SEARCH" mode.

Press the TIME SEARCH button (with each push it will increase by 10 minutes).

### OR

Press the MENU button on the remote control.

Press the PLAY or STOP button to point to "TIME SEARCH".

Then, press the F.FWD button.

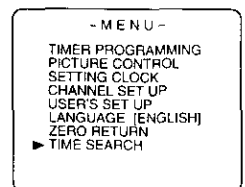

- 3 Enter your desired time.

Press the PLAY or STOP button until your desired time appears.

(Example: "2:50" stands for 2 hours 50 minutes)

If you wish to cancel the Time Search at this point, press the MENU button on the remote control.

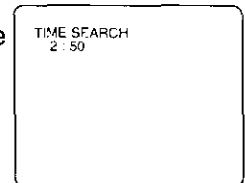

- 4 Begin Time Search

Press the REW or F.FWD button.

The TV/VCR will rewind or fast forward to the specified point.

The time counts down as the searching progresses. When 0:00 is reached, the tape will start playback automatically.

### TO CANCEL THE TIME SEARCH MODE

Press the STOP/EJECT button on the TV/VCR or the remote control. This will delete the selected time.

# RECORDING

## Make sure:

- TV/VCR power must be turned on.
- Insert a cassette tape with its erase prevention tab in place. (If necessary, rewind or fast forward the tape to the point you want to begin recording.)

## Normal Recording

You can **ONLY** watch the same TV program that is being recorded.

### 1 Select the channel to be recorded

Press the number buttons on the remote control or the CHANNEL UP or DOWN button.

Remember: If the TV/VCR is connected to a cable box or satellite box, the TV/VCR must be on CH3 or CH4.

Then the channel to be recorded must be selected on the cable box or satellite box.

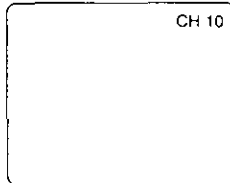

### 2 Select the tape speed

Press the SPEED button to select the desired tape speed (SP/ SLP).

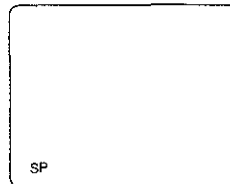

### 3 Begin recording

Press the REC(ORD) button.

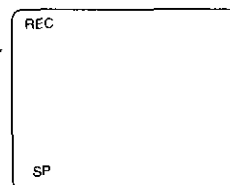

### 4 Stop recording

Press the STOP button when recording is completed.

## Skipping Unwanted Scenes During Recording

Press the PAUSE/STILL button to temporarily stop recording.

Press the PAUSE/STILL or REC(ORD) button to resume recording.

### NOTE:

- After five minutes, the TV/VCR will automatically switch to the Recording mode to prevent tape damage.

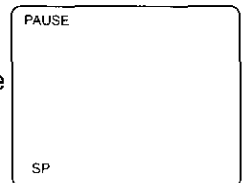

## OTR (One Touch Recording)

This function enables you to set a recording length simply by pressing the REC/OTR button on the TV/VCR.

### Make sure:

- TV/VCR power must be turned on.
- Insert a cassette tape with its erase prevention tab in place. (If necessary, rewind or fast forward the tape to the point you want to begin recording.)

### NOTE:

- This function CANNOT be done from the remote control.
- Recording starts immediately when the REC/OTR button is pressed.
- When the REC/OTR button is pressed 18 times, the TV/VCR returns to the Normal Recording mode.
- To stop the OTR operation, press the STOP button on the TV/VCR or on the remote control.
- To show the remaining time, press the DISPLAY button on the remote control so that "OTR" appears on the TV screen. (It will show up momentarily then disappear.)
- Recording stops when 0:00 is reached.
- Please note that in the SLP mode, maximum recording time, is 8 hours using a T-160 or 6 hours using T-120 tape.
- If the tape runs out before the end time, the TV/VCR will switch to the Stop mode immediately, ejects the tape and turns itself off.

### 1 Select the channel to be recorded

Press the number buttons on the remote control or the CHANNEL UP or DOWN button.

**Remember:** If the TV/VCR is connected to a cable box or satellite box, the TV/VCR must be on CH3 or CH4, then the channel to be recorded is selected on the cable box or satellite box.

### 2 Select the tape speed

Press the SPEED button to select the desired tape speed (SP/SLP).

### 3 Begin recording

Press the REC/OTR button once to begin recording.

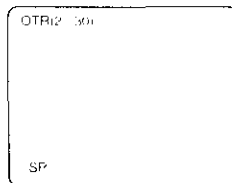

Press twice to set recording length to 30 minutes. Each additional push of the button will increase the recording time by 30 minutes, up to a total of 480 minutes.

Push(es)	Display	Recording length
1 push		(Begin Recording)
2 pushes	0:30	30 minutes
3 pushes	1:00	60 minutes
↓	↓	↓
17 pushes	8:00	480 minutes

## Copying a Video Cassette (From a VCR or camcorder)

Unauthorized recordings of copyrighted video tapes may be an infringement of copyright laws.

Connect your TV/VCR and a Source (Playing) VCR using the following diagram.

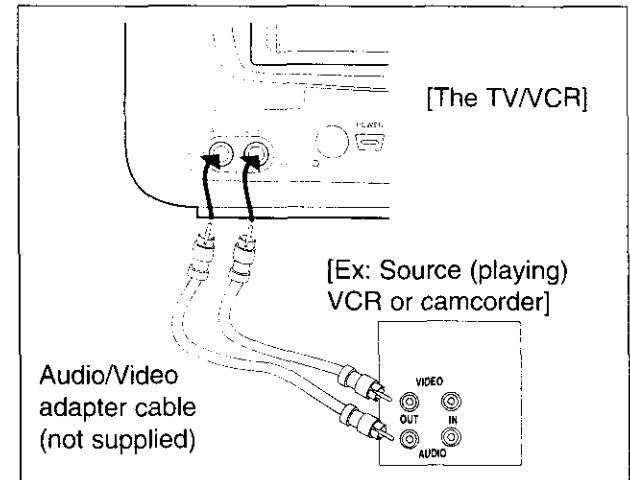

- 1) Insert a pre-recorded video cassette into the Source (Playing) VCR.
- 2) Insert a blank video cassette, or one you want to record over, into the TV/VCR's cassette compartment.
- 3) Press the SPEED button on remote control for the TV/VCR to select the desired recording speed (SP/SLP).
- 4) Press the CHANNEL UP or DOWN button on the TV/VCR until "AUX" appears on the screen.
- 5) Press the REC(ORD) button on the TV/VCR.
- 6) Begin playback of the tape in the source (Playing) VCR or camcorder.

**NOTE:** For best results during copying, use the TV/VCR's front panel controls whenever possible. The remote control might affect the source (Playing) VCR's playback operation.



# TIMER

## Automatic Timer Recording

You may set the TV/VCR to start and end a recording while you are away. You can set 8 programs to record on specific days, daily or weekly within a 1 year period.

The example to the right shows how to set the timer to record channel 7 on July 6th, 2000 from 7:30 PM to 8:50 PM at SP tape speed.

### Make sure:

- If a cable or satellite converter is connected to the TV/VCR, you must set the channel you want to record on the converter (The TV/VCR should always be set to channel 3 or 4).
- Clock must be set to the correct time and date before setting the timer.
- TV/VCR must be turned on to program it.
- Insert a cassette tape with its erase prevention tab in place. If necessary, rewind or fast forward the tape to the point at which you want to begin recording.

### Avoid overlapping of programs

Programs with overlapping starting times may result in some of the programs not recording.

When programs overlap:

- The program with the earliest starting time has recording priority.
- Once the program with the earliest starting time finishes, recording then proceeds according to the sequence in which the programs were entered.
- In the example below, the first 1 1/2 hours of Program 3 were not recorded. The first half-hour was pre-empted by Program 2, which had the earliest starting time. The next hour was pre-empted by Program 1, which was the first program entered into the recording sequence.

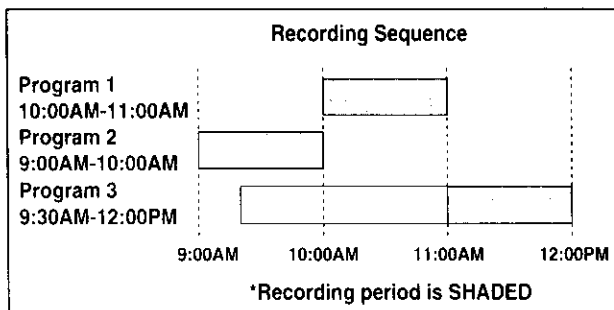

### 1 Select "TIMER PROGRAMMING"

Press the MENU button on the remote control.

Confirm "TIMER PROGRAMMING" is pointed by pressing the PLAY button.

Then press the F.FWD button.

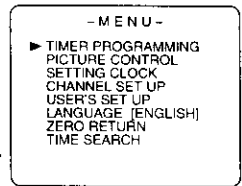

- If you have not yet set the clock, "MANUAL CLOCK SETTING" appears. If so, follow steps [3] to [8] on page 17. Then set the timer recording.

### 2 Set your desired program position

Press the PLAY or STOP button to select the desired program position.

Then, press the F.FWD button.

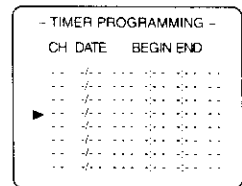

### 3 Set the channel number

Press the PLAY or STOP button until the desired channel number appears. (Example: CH7)

Then, press the F.FWD button.

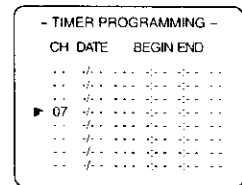

**Remember:** If the TV/VCR is connected to a cable box or satellite box, the TV/VCR must be on CH3 or CH4, then the channel to be recorded is selected on the cable box or satellite box.

### 4 Select ONCE, EVERY DAY or WEEKLY recording

#### For ONCE recording :

Press the PLAY (up) button until the desired date appears. (Example: "7/06" for July 6th). Then, press the F.FWD button.

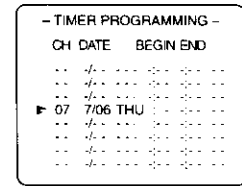

**For EVERY DAY recording :** To record a TV program at the same time on the same channel every day (Example: Monday through Sunday).

Press the STOP (down) button until "EVERY DAY" appears. Then, press the F.FWD button.

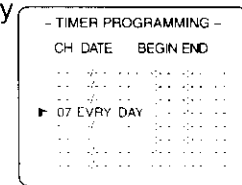

**For WEEKLY recording :** To record a TV program at the same time on the same channel every week (Example: every Monday).

Press the STOP (down) button until "EVRY" and your desired day of the week appear together. Then, press the F.FWD button.

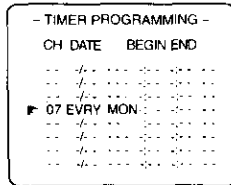

**5 Set beginning hour**  
Press the PLAY or STOP button until the desired hour appears. (Example: " 7, PM" for 7:30PM)

Then, press the F.FWD button.

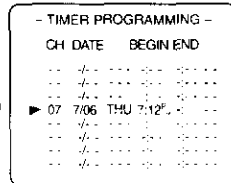

**6 Set beginning minute**  
Press the PLAY or STOP button until the desired minute appears. (Example: "30" for 7:30PM)

Then, press the F.FWD button.

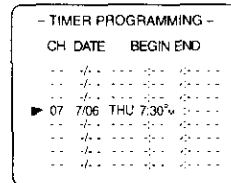

**7 Set end hour**  
Press the PLAY or STOP button until the desired hour appears. (Example: "8, PM" for 8:50PM)

Then, press the F.FWD button.

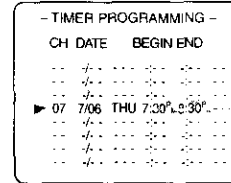

**8 Set end minute**  
Press the PLAY or STOP button until the desired minute appears. (Example: "50" for 8:50PM)

Then, press the F.FWD button.

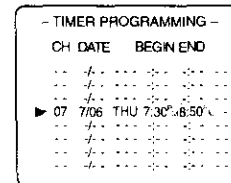

**9 Set the tape speed**  
Press the PLAY or STOP button until the desired tape speed appears. (Example: SP)

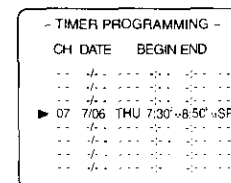

**10 Finish setting the program**  
Press the F.FWD or REW button. The program is now completed.

- To set another program, repeat steps [2] to [10].
- Press the MENU button on the remote control to return to original mode.

**11 Set the timer**  
Press the PWR(POWER) button to set automatic timer recording. The TIMER REC indicator lights up.

- You must turn off the TV/VCR to activate automatic timer recording.  
If power is not turned off and you continue watching TV, "TIMER REC STANDBY" starts flashing on the TV screen 2 minutes before the programmed start time.

### Timer Program Extension

**NOTE:** Any timer recording that is in progress while you perform the following adjustments will continue recording undisturbed.

To set the schedule of a timer recording forward:

- 1) If television is OFF, press the PWR(POWER) button to turn it ON.
  - 2) Press the MENU button on the remote control. Use the PLAY or STOP button to move selection arrow to TIMER PROGRAMMING. Press the F.FWD button to enter the TIMER PROGRAMMING screen.
  - 3) Press the REC(ORD) button once to enter the adjustment mode, then use the PLAY or STOP button to select the recording you want to adjust.
  - 4) Press the REC(ORD) button to set the scheduled BEGIN and END time forward 10 minutes. Each additional press will set the time forward another 10 minutes. (If you choose a recording currently in progress, the BEGIN time will not be affected.) While performing this procedure, you may cancel the new setting and return to the original one by pressing the PAUSE/STILL button.
- NOTE:** If you choose a recording currently in progress, the recording speed will automatically be set to SLP to preserve tape length.
- 5) Press the F.FWD or REW button to exit the adjustment mode. Then press the MENU button on the remote control to exit the TIMER PROGRAMMING screen.
  - 6) If desired, press the PWR(POWER) button to turn the television OFF.

## TO CORRECT A PROGRAM

- **While setting a program;** press the REW button to go back one step and enter the correct numbers using the PLAY or STOP button.
- **After setting a program;**
  - 1) Press the PWR(POWER) button.
  - 2) Repeat steps [1] - [2] on page 25.
  - 3) Press the F.FWD button (or press the REW button to go back one step) until the part you want to correct begins flashing, then make the changes pressing the PLAY or STOP button.
  - 4) Press the PWR(POWER) button to set automatic timer recording.

## TO CANCEL AN AUTOMATIC TIMER RECORDING

- **After setting a program;**
  - 1) Press the PWR(POWER) button.
  - 2) Repeat steps [1] - [2] on page 25 and select a program you want to cancel.
  - 3) Press the T-PROG. CLEAR button.
  - 4) Press the MENU button on the remote control to return to TV mode.
- **While recording is in progress;**
  - 1) Press the PWR(POWER) button.
  - 2) Press the STOP/EJECT button on the TV/VCR.

## TO CHECK THE BEGIN/END TIME

- 1) Press the PWR(POWER) button so that the REC indicator goes off.
- 2) Press the MENU button on the remote control.
- 3) Confirm "TIMER PROGRAMMING" is pointed to.
- 4) Press the F.FWD button. The details of programs appear on the TV screen.
- 5) Press the MENU button on the remote control to return to TV mode.

### AUTO TIMER RECORDING REMINDERS:

- Make sure the channel you want to record is properly set in advance.
- It is not necessary to press the REC(ORD) button for timer recording.
- Recording begins automatically at the Start time.
- If you are recording using a Timer mode, you cannot operate the unit manually.
- The erase-prevention tab on the cassette must be in place (or you must put tape over the hole).

- If the erase-prevention tab is removed, the cassette will be ejected when the PWR(POWER) button is pressed to off.
- If the tape runs out before the end time, the TV/VCR will switch to the Stop mode immediately, and the tape will be ejected.

## Auto Return

With this function, after timer recording is finished, the tape will automatically rewind to the start of the recorded program(s).

### 1. Press the MENU button on the remote control.

Press the MENU button on the remote control.

Press the PLAY or STOP button to point to "USER'S SET UP".

Then, press the F.FWD button.

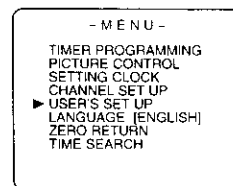

### 2. Press the F.FWD button to point to "AUTO RETURN" to [ON].

Press the PLAY or STOP button to point to "AUTO RETURN".

Press the F.FWD or REW button until [ON] appears.

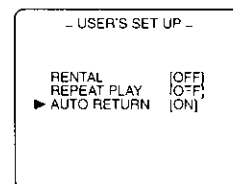

### 3. Auto Return will begin

When all the timer recordings are completed, the TV/VCR will rewind to the beginning of the recorded program(s).

### NOTE:

- If you press the PWR(POWER) button while tape is rewinding, the Auto Return will stop.

### 4. Watch the recorded program

Press the PLAY button.

## TO CANCEL THE AUTO RETURN MODE

Repeat steps [1] and [2], select [OFF] using the F.FWD or REW button.

**If there is a power failure of any kind, the unit will retain its memory for this feature.**

## Wake Up Timer

The Wake Up Timer function turns on the TV/VCR after a desired period of time without using the PWR(POWER) button.

### NOTE:

- Use the remote control for this procedure.
- Clock must be set to the correct time before setting the timer.
- If you want to select [TAPE], you must insert a cassette tape in the TV/VCR. The tape will start playback automatically on your desired time.

#### 1 Select "WAKE UP TIMER"

Press the WAKE UP/SLEEP button on the remote control once, and confirm "ON/OFF" is pointed to.

Press the F.FWD or REW button until [ON] appears.

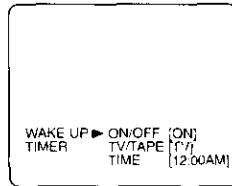

#### 2 Select "TV" or "TAPE"

Press the PLAY or STOP button until it points to "TV/TAPE".

Press the F.FWD or REW button, and select [TV] or [TAPE].

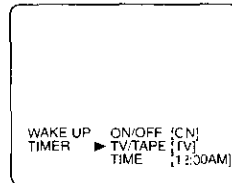

#### 3 Set wake up time

Press the PLAY or STOP button until it points to "TIME".

Press the F.FWD or REW button until your desired wake up time appears.

Each additional push will increase (or decrease) the time by 10 minutes.

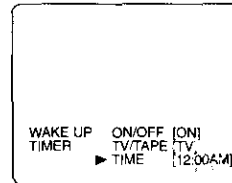

#### 4 Exit the Wake Up Timer setting

Press the MENU button on the remote control to return to TV mode.

#### TO CANCEL THE WAKE UP TIMER

Repeat step [1] but select [OFF].

## Sleep Timer

The Sleep Timer function turns off the TV/VCR automatically after a desired period of time.

### NOTE:

- This function does not operate during Recording mode.

#### 1 Select "SLEEP TIMER"

Press the WAKE UP/SLEEP button on the remote control until "SLEEP TIMER" appears.

#### 2 Set sleep time

Press the PLAY, STOP, F.FWD or REW button until your desired sleep time appears.

Each additional push will increase the time by 30 minutes up to 120 minutes.

Press the MENU button on the remote control to exit the Sleep Timer setting.

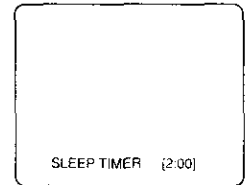

#### TO CANCEL THE SLEEP TIMER

Press the WAKE UP/SLEEP button on the remote control until "SLEEP TIMER" appears.

Then, press the PLAY, STOP, F.FWD or REW button and select [OFF].

To view the time left for sleep timer press the WAKE UP/SLEEP button twice; then press the MENU button on the remote control to exit the sleep timer setting.

## MAINTENANCE

---

### CABINET CLEANING

- Wipe the front panel and other exterior surfaces of the TV/VCR with a soft cloth immersed in lukewarm water and wrung dry.
- Never use a solvent or alcohol. Do not spray insecticide liquid near the TV/VCR. Such chemicals may cause damage and discoloration to the exposed surfaces.

### SERVICING

- Should your TV/VCR become inoperative, do not try to correct the problem by yourself. There are no user-serviceable parts inside. Turn off, unplug the power cord, and take the unit to the nearest Sears Service Center. To locate the nearest Sears Service Center, call 1-800-488-1222.

### HEAD CLEANING

- Playback picture may become blurred or interrupted while the TV program reception is clear. Dirt accumulated on the video heads after long periods of use, or the usage of rental or worn tapes can cause this problem. If a streaky or snowy picture appears during playback, the heads of your TV/VCR may need to be cleaned.
1. Please visit your local Audio/Video store and purchase a good quality VHS Video Head Cleaner.
  2. If a Video Head Cleaner does not solve the problem, consult the nearest Sears Service Center. Professional video head cleaning requires highly technical attention.

### NOTES:

- Remember to read the instructions included with the head cleaner **before use**.
- Clean heads only when problems occur.

## TROUBLESHOOTING GUIDE

PROBLEM	CORRECTIVE ACTION
No power.	<ul style="list-style-type: none"> <li>• Make sure the AC cord is connected to an AC outlet.</li> <li>• Make sure car adapter cord is connected to car's cigarette lighter socket and to the DC13.2V jack on back of unit.</li> <li>• Check the 5A, 250V fuse in the car adapter cord.</li> <li>• Make sure the power is turned on.</li> </ul>
No picture and sound.	<ul style="list-style-type: none"> <li>• Make sure the AC cord is connected to an AC outlet.</li> <li>• Check antenna connection.</li> <li>• Perform channel set-up again.</li> </ul>
No picture or poor picture on TV/VCR.	<ul style="list-style-type: none"> <li>• Adjust direction or replace antenna.</li> <li>• Adjust picture controls.</li> </ul>
No sound or poor sound.	<ul style="list-style-type: none"> <li>• Adjust volume control on remote control or main unit.</li> <li>• Press the MUTE button to restore sound.</li> </ul>
Timer recording is not possible.	<ul style="list-style-type: none"> <li>• Make sure the timer recording is set correctly.</li> <li>• Make sure the power is off.</li> <li>• Make sure the TV/VCR clock is set correctly.</li> </ul>
Cannot go into Record mode.	<ul style="list-style-type: none"> <li>• Make sure the tape has an erase-prevention tab. If necessary, cover the hole with plastic tape.</li> </ul>
Playback picture has some video noise lines.	<ul style="list-style-type: none"> <li>• Adjust tracking control for a better picture using the CHANNEL UP or DOWN button on the TV/VCR.</li> </ul>
No picture but the audio is OK in playback.	<ul style="list-style-type: none"> <li>• Head cleaning may be necessary. Refer to "HEAD CLEANING" on page 29.</li> </ul>
No operation by infrared Remote Control.	<ul style="list-style-type: none"> <li>• Make sure the AC cord is connected to an AC outlet.</li> <li>• Check batteries in remote control.</li> </ul>
Video or color fades in and out when making a copy of a video tape.	<ul style="list-style-type: none"> <li>• You can not copy a copyrighted video tape. You are experiencing copy guard protection.</li> </ul>
Cannot set the auto clock to ON.	<ul style="list-style-type: none"> <li>• Make sure car adapter cord is not connected to the TV/VCR.</li> </ul>
"DEW" appears on the screen.	<ul style="list-style-type: none"> <li>• Refer to page 6 "CAUTION".</li> </ul>

**MEMO**

