

# Owner's Manual

## **CRAFTSMAN®** **6.75 HORSEPOWER** **22" REAR DISCHARGE** **POWER PROPELLED** **ROTARY LAWN MOWER**

Model No.  
**917.377390**

- **Safety**
- **Assembly**
- **Operation**
- **Maintenance**
- **Español**
- **Repair Parts**



### **CAUTION:**

Read and follow all  
Safety Rules and Instructions  
before operating this equipment

Sears, Roebuck and Co., Hoffman Estates, IL 60179

Visit our Craftsman website: [www.sears.com/craftsman](http://www.sears.com/craftsman)

## TABLE OF CONTENTS

Warranty	2	Product Specifications	11
Safety Rules	2	Service and Adjustments	14
Assembly	4	Storage	16
Operation	6	Troubleshooting	17
Maintenance Schedule	10	Repair Parts	37
Maintenance	10	Parts Ordering	Back Cover

## WARRANTY

### LIMITED TWO YEAR WARRANTY ON CRAFTSMAN POWER MOWER

For two years from date of purchase, when this Craftsman Lawn Mower is maintained, lubricated, and tuned up according to the operating and maintenance instructions in the owner's manual, Sears will repair free of charge any defect in material or workmanship. If this Craftsman Lawn Mower is used for commercial or rental purposes, this warranty applies for only 90 days from the date of purchase.

This Warranty does not cover:

- Expendable items which become worn during normal use, such as rotary mower blades, blade adapters, belts, air cleaners and spark plug.
- Repairs necessary because of operator abuse or negligence, including bent crankshafts and the failure to maintain the equipment according to the instructions contained in the owner's manual.

Warranty service is available by returning the Craftsman power mower to the nearest Sears Service Center/Department in the United States. This warranty applies only while this product is in use in the United States.

This Warranty gives you specific legal rights, and you may also have other rights which vary from state to state.

SEARS, ROEBUCK AND CO., D/817 WA, HOFFMAN ESTATES, ILLINOIS 60179

## SAFETY RULES

Safety standards require operator presence controls to minimize the risk of injury. Your unit is equipped with such controls. Do not attempt to defeat the function of the operator presence controls under any circumstances.

### TRAINING:

- Read this operator's manual carefully. Become familiar with the controls and know how to operate your mower properly. Learn how to quickly stop mower.
- Do not allow children to use your mower. Never allow adults to use mower without proper instructions.
- Keep the area of operation clear of all persons, especially small children and pets.
- Use mower only as the manufacturer intended and as described in this manual.

- Do not operate mower if it has been dropped or damaged in any manner. Always have damage repaired before using your mower.
- Do not use accessory attachments that are not recommended by the manufacturer. Use of such attachments may be hazardous.
- The blade turns when the engine is running.

### PREPARATION:

- Always thoroughly check the area to be mowed and clear it of all stones, sticks, wires, bones, and other foreign objects. These objects will be thrown by the blade and can cause severe injury.
- Always wear safety glasses or eye shields when starting and while using your mower.
- Dress properly. Do not operate mower when barefoot or wearing open sandals. Wear only solid shoes with good traction when mowing.

- Check fuel tank before starting engine. Do not fill gas tank indoors, when the engine is running or when the engine is hot. Allow the engine to cool for several minutes before filling the gas tank. Clean off any spilled gasoline before starting the engine.
- Always make wheel height adjustments before starting your mower. Never attempt to do this while the engine is running.
- Mow only in daylight or good artificial light.

### **OPERATION:**

- Keep your eyes and mind on your mower and the area being cut. Do not let other interests distract you.
- Do not mow wet or slippery grass. Never run while operating your mower. Always be sure of your footing — keep a firm hold on the handles and walk.
- Do not put hands or feet near or under rotating parts. Keep clear of the discharge opening at all times.
- Always stop the engine whenever you leave or are not using your mower, or before crossing driveways, walks, roads, and any gravel—covered areas.
- Never direct discharge of material toward bystanders nor allow anyone near the mower while you are operating it.
- Before cleaning, inspecting, or repairing your mower, stop the engine and make absolutely sure the blade and all moving parts have stopped. Then disconnect the spark plug wire and keep it away from the spark plug to prevent accidental starting.
- Do not continue to run your mower if you hit a foreign object. Follow the procedure outlined above, then repair any damage before restarting and operating you mower.
- Do not change the governor settings or overspeed the engine. Engine damage or personal injury may result.
- Do not operate your mower if it vibrates abnormally. Excessive vibration is an indication of damage; stop the engine, safely check for the cause of vibration and repair as required.
- Do not run the engine indoors. Exhaust fumes are dangerous.

- Never cut grass by pulling the mower towards you. Mow across the face of slopes, never up and down or you might lose your footing. Do not mow excessively steep slopes. Use caution when operating the mower on uneven terrain or when changing directions — maintain good footing.
- Never operate your mower without proper guards, plates, grass catcher or other safety devices in place.

### **MAINTENANCE AND STORAGE:**

- Check the blade and the engine mounting bolts often to be sure they are tightened properly.
- Check all bolts, nuts and screws at frequent intervals for proper tightness to be sure mower is in safe working condition.
- Keep all safety devices in place and working.
- To reduce fire hazard, keep the engine free of grass, leaves or excessive grease and oil.
- Check grass catcher often for deterioration and wear and replace worn bags. Use only replacement bags that are recommended by and comply with specifications of the manufacturer of your mower.
- Always keep a sharp blade on your mower.
- Allow engine to cool before storing in any enclosure.
- Never store mower with fuel in the tank inside a building where fumes may reach an open flame or an ignition source such as a hot water heater, space heater, clothes dryer, etc.

**▲** Look for this symbol to point out important safety precautions. It means **CAUTION!!! BECOME ALERT!!! YOUR SAFETY IS INVOLVED.**

**▲CAUTION:** Always disconnect spark plug wire and place wire where it cannot contact spark plug in order to prevent accidental starting when setting up, transporting, adjusting or making repairs.



### **▲WARNING**

The engine exhaust from this product contains chemicals known to the State of California to cause cancer, birth defects, or other reproductive harm.



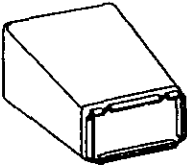
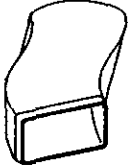
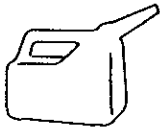

## ACCESSORIES

These accessories were available when this lawn mower was produced. They are not shipped with your mower. They are also available at most Sears retail outlets and service centers. Most Sears stores can also order repair parts for you, when you provide the model number of your lawn mower. Some of these accessories may not apply to your lawn mower.

### LAWN MOWER PERFORMANCE

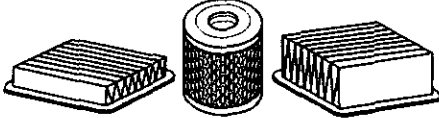
 <p><b>CLIPPING DEFLECTOR FOR REAR DISCHARGE LAWN MOWERS</b></p>	 <p><b>MULCHER KITS</b></p>	 <p><b>STABILIZER</b></p>
 <p><b>GRASS CATCHERS FOR REAR DISCHARGE LAWN MOWERS</b></p>	 <p><b>GRASS CATCHERS FOR SIDE DISCHARGE LAWN MOWERS</b></p>	 <p><b>GAS CANS</b></p>

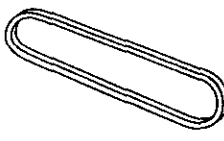
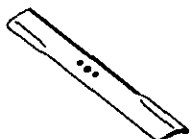
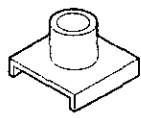
### LAWN MOWER MAINTENANCE

 <p><b>MUFFLERS</b></p>		 <p><b>AIR FILTERS</b></p>		 <p><b>SPARK PLUGS</b></p>
 <p><b>BELTS</b></p>	 <p><b>BLADES</b></p>	 <p><b>BLADE ADAPTERS</b></p>	 <p><b>WHEELS</b></p>	 <p><b>ENGINE OIL</b></p>

## ASSEMBLY

Read these instructions and this manual in its entirety before you attempt to assemble or operate your new lawn mower.

**IMPORTANT:** This lawn mower is shipped WITHOUT OIL OR GASOLINE in the engine. Your new lawn mower has been assembled at the factory with the exception of those parts left unassembled for shipping purposes. All parts such as nuts, washers, bolts, etc., necessary to complete the assembly have been placed in the parts bag. To ensure safe and proper operation of your lawn mower, all parts and hardware you assemble must be tightened securely. Use the correct tools as necessary to ensure proper tightness.

### TO REMOVE LAWN MOWER FROM CARTON

- Remove loose parts included with mower.
- Cut down two end corners of carton and lay end panel down flat.
- Remove all packing materials except padding between upper and lower handle and padding holding operator presence control bar to upper handle.
- Roll lawn mower out of carton and check carton thoroughly for additional loose parts.

## HOW TO SET UP YOUR LAWN MOWER TO UNFOLD HANDLE

**IMPORTANT:** Unfold handles carefully so as not to pinch or damage control cables.

- Raise handles until lower handle section locks into place in mowing position.
- Remove protective padding, raise upper handle section into place on lower handle and tighten both handle knobs.
- Remove handle padding holding operator presence control bar to upper handle.
- Your lawn mower handle can be adjusted for your mowing comfort. Refer to "Adjust Handle" in the Service and Adjustment section of this manual.

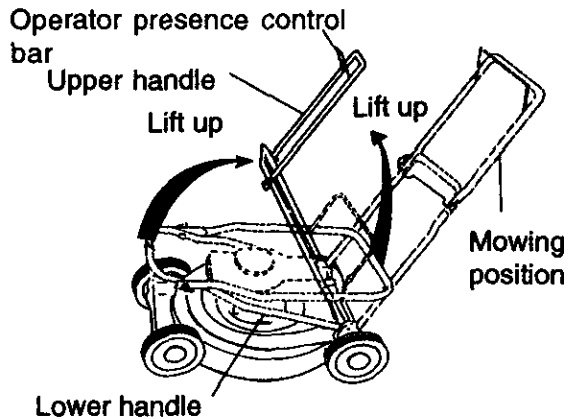

## TO INSTALL ATTACHMENTS

Your lawn mower was shipped ready to be used as a mulcher. To convert to bagging or discharging:

- Open rear door and remove mulcher plug. Store mulcher plug in a safe place.
- You can now install catcher or optional clipping deflector.
- To return to mulching operation, install mulcher plug into discharge opening of mower. Be sure all tabs are seated properly.

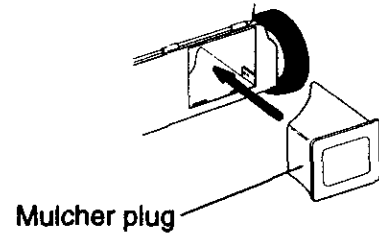

**CAUTION:** Do not run your lawn mower without mulcher plug in place or approved clipping deflector or grass catcher in place. Never attempt to operate the lawn mower with the rear door removed or propped open.

# OPERATION

## KNOW YOUR LAWN MOWER

READ THIS OWNER'S MANUAL AND SAFETY RULES BEFORE OPERATING YOUR LAWN MOWER. Compare the illustrations with your lawn mower to familiarize yourself with the location of various controls and adjustments. Save this manual for future reference.

These symbols may appear on your lawn mower or in literature supplied with the product. Learn and understand their meaning.

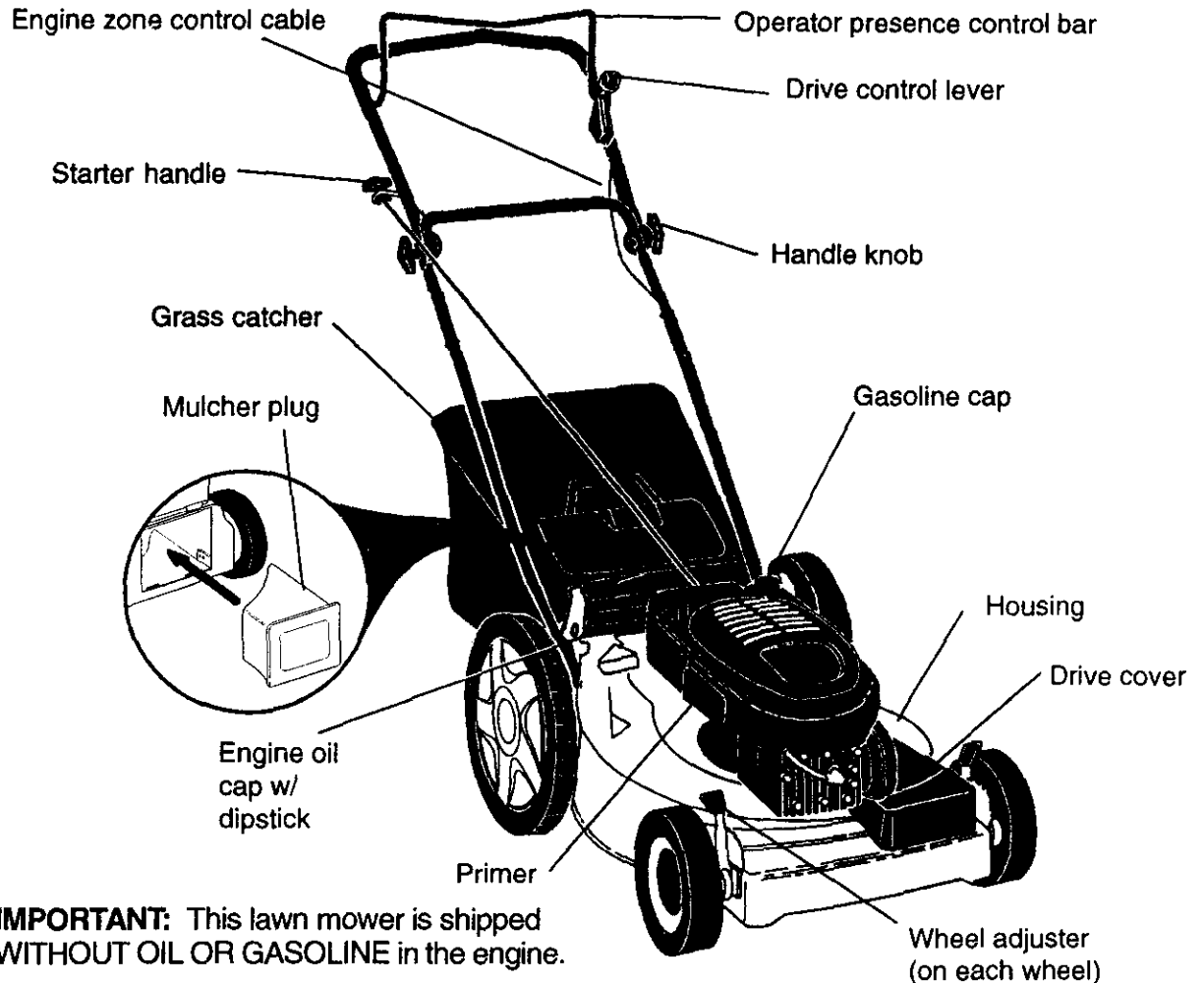
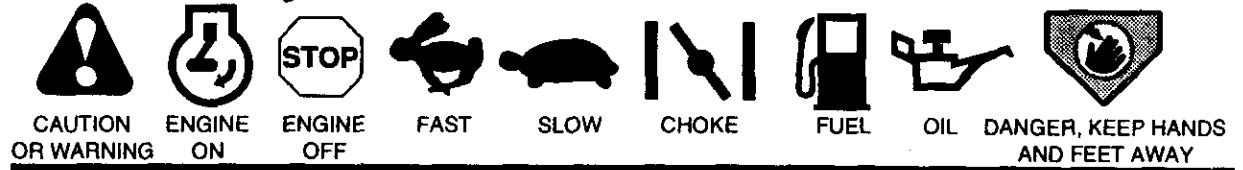

**IMPORTANT:** This lawn mower is shipped WITHOUT OIL OR GASOLINE in the engine.

### MEETS CPSC SAFETY REQUIREMENTS

Sears rotary walk-behind power lawn mowers conform to the safety standards of the American National Standards Institute and the U.S. Consumer Product Safety Commission. The blade turns when the engine is running.

**Operator presence control bar** - must be held down to the handle to start the engine. Release to stop the engine.

**Primer** - pumps additional fuel from the carburetor to the cylinder for use when starting a cold engine.

**Starter handle** - used for starting the engine.  
**Drive control lever** - used to engage power-propelled forward motion of lawn mower.

**Mulcher plug** - must be removed to convert to bagging or discharging operation.



The operation of any lawn mower can result in foreign objects thrown into the eyes, which can result in severe eye damage. Always wear safety glasses or eye shields while operating your lawn mower or performing any adjustments or repairs. We recommend a wide vision safety mask over spectacles or standard safety glasses.

### HOW TO USE YOUR LAWN MOWER ENGINE SPEED

The engine speed was set at the factory for optimum performance. Speed is not adjustable.

### ENGINE ZONE CONTROL

**CAUTION:** Federal regulations require an engine control to be installed on this lawn mower in order to minimize the risk of blade contact injury. Do not under any circumstances attempt to defeat the function of the operator control. The blade turns when the engine is running.

- Your lawn mower is equipped with an operator presence control bar which requires the operator to be positioned behind the lawn mower handle to start and operate the lawn mower.

### TO ADJUST CUTTING HEIGHT

- Raise wheels for low cut and lower wheels for high cut.
- Adjust cutting height to suit your requirements. Medium position is best for most lawns.
- To change cutting height, squeeze adjuster lever toward wheel. Move wheel up or down to suit your requirements. Be sure all wheels are in the same setting.

**NOTE:** Adjuster is properly positioned when plate tab inserts into hole in lever. Also, 9-position adjusters (if so equipped) allow lever to be positioned between the plate tabs.

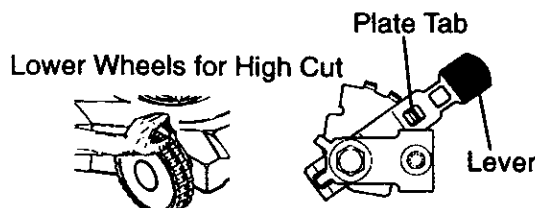

Raise Wheels for Low Cut

### TO ATTACH GRASS CATCHER

- Lift the rear door of the lawn mower and place the grass catcher frame hooks onto the door pivot pins.
- The grass catcher is secured to the lawn mower housing when the rear door is lowered onto the grass catcher frame.

**CAUTION:** Do not run your lawn mower without clipping deflector or approved grass catcher in place. Never attempt to operate the lawn mower with the rear door removed or propped open.

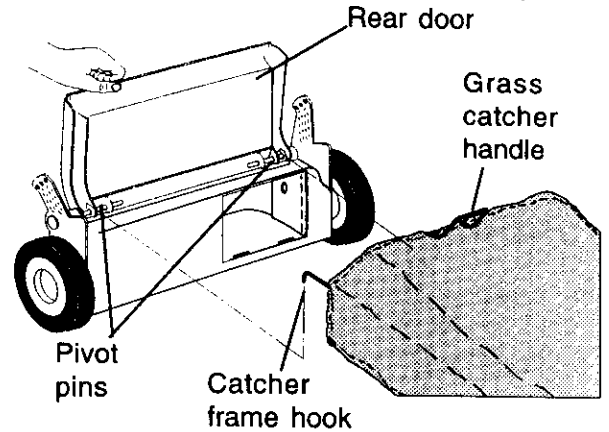

### TO EMPTY GRASS CATCHER

- Lift up on grass catcher using the frame handle.
- Remove grass catcher with clippings from under lawn mower handle.
- Empty clippings from bag using both frame handle and bag handle.

**NOTE:** Do not drag the bag when emptying; it will cause unnecessary wear.

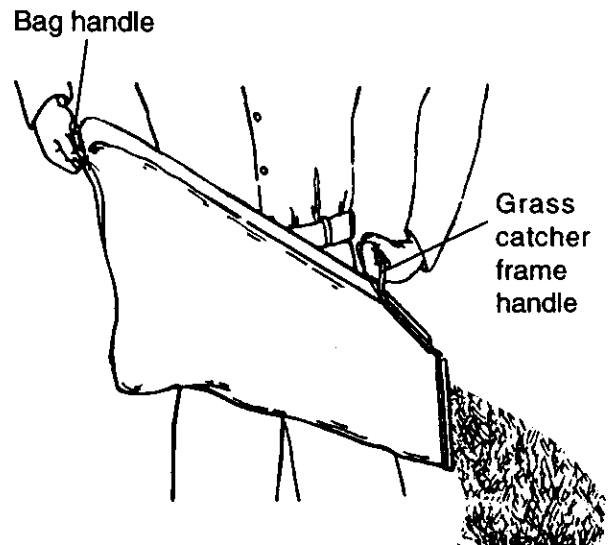

## DRIVE CONTROL

- Self-propelling is controlled by holding the operator presence control bar down to the handle and pushing the drive control lever forward until it clicks; then release the lever.
- Forward motion will stop when the operator presence control bar is released. To stop forward motion without stopping engine, release the operator presence control bar slightly until the drive control disengages. Hold operator presence control bar down to handle to continue mowing without self-propelling.
- To keep drive control engaged when turning corners, push down on handle and lift front wheels off ground while turning lawn mower.

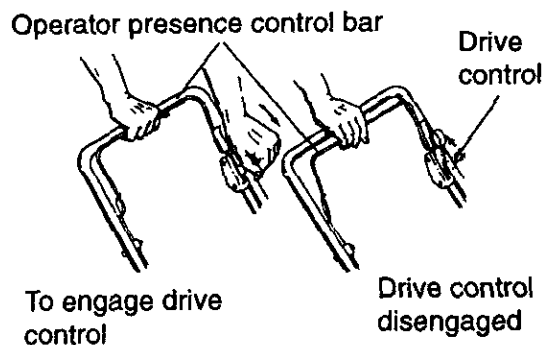

## BEFORE STARTING ENGINE

### OIL

Your lawn mower is shipped without oil in the engine.

- Be sure mower is level and area around oil fill is clean.
- Remove engine oil cap and fill to the full line on the dipstick.

**NOTE:** Allow oil to settle down into engine for accurate dipstick reading.

- Engine holds 20 ozs. of oil. For type and grade of oil to use, see "ENGINE" in Maintenance section of this manual.
- Pour oil slowly. Do not over fill.
- Check oil level before each use. Add oil if needed. Fill to full line on dipstick.
- To read proper level, tighten engine oil cap each time.
- Reinstall engine oil cap and tighten.
- Change the oil after every 25 hours of operation or each season. You may need to change the oil more often under dusty, dirty conditions.

## ADD GASOLINE

- Fill fuel tank. Use fresh, clean, regular unleaded gasoline with a minimum of 87 octane. Do not mix oil with gasoline. Purchase fuel in quantities that can be used within 30 days to assure fuel freshness.

**WARNING:** Experience indicates that alcohol blended fuels (called gasohol or using ethanol or methanol) can attract moisture which leads to separation and formation of acids during storage. Acidic gas can damage the fuel system of an engine while in storage. To avoid engine problems, the fuel system should be emptied before storage of 30 days or longer. Drain the gas tank, start the engine and let it run until the fuel lines and carburetor are empty. Use fresh fuel next season. See Storage Instructions for additional information. Never use engine or carburetor cleaner products in the fuel tank or permanent damage may occur.

**CAUTION:** Fill to bottom of gas tank filler neck. Do not overfill. Wipe off any spilled oil or fuel. Do not store, spill or use gasoline near an open flame.

Engine oil cap      Gasoline filler cap

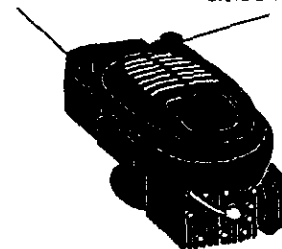

## TO START ENGINE

- To start a cold engine, push primer three (3) times before trying to start. Use a firm push. This step is not usually necessary when starting an engine which has already run for a few minutes.
- Hold operator presence control bar down to the handle and pull starter handle quickly. Do not allow starter rope to snap back.
- To stop engine, release operator presence control bar.

**NOTE:** In cooler weather it may be necessary to repeat priming steps. In warmer weather over priming may cause flooding and engine will not start. If you do flood engine, wait a few minutes before attempting to start and do not repeat priming steps.



## MOWING TIPS

- Under certain conditions, such as very tall grass, it may be necessary to raise the height of cut to reduce pushing effort and to keep from overloading the engine and leaving clumps of grass clippings. It may also be necessary to reduce ground speed and/or run the lawn mower over the area a second time.
- For extremely heavy cutting, reduce the width of cut by overlapping previously cut path and mow slowly.
- For better grass bagging and most cutting conditions, the engine speed should be set in the fast position.
- When using a rear discharge lawn mower in moist, heavy grass, clumps of cut grass may not enter the grass catcher. Reduce ground speed (pushing speed) and/or run the lawn mower over the area a second time.
- If a trail of clippings is left on the right side of a rear discharge mower, mow in a clockwise direction with a small overlap to collect the clippings on the next pass.
- Pores in cloth grass catchers can become filled with dirt and dust with use and catchers will collect less grass. To prevent this, regularly hose catcher off with water and let dry before using.
- Keep top of engine around starter clear and clean of grass clippings and chaff. This will help engine air flow and extend engine life.

## MULCHING MOWING TIPS

**IMPORTANT:** For best performance, keep mower housing free of built-up grass and trash. See "Cleaning" in Maintenance section of this manual.

- The special mulching blade will recut the grass clippings many times and reduce them in size so that as they fall onto the lawn they will disperse into the grass and not be noticed. Also, the mulched grass will biodegrade quickly to provide nutrients for the lawn. Always mulch with your highest engine (blade) speed as this will provide the best recutting action of the blades.
- Avoid cutting your lawn when it is wet. Wet grass tends to form clumps and interferes with the mulching action. The best time to mow your lawn is the early afternoon. At this time the grass has dried and the newly cut area will not be exposed to the direct sun.
- For best results, adjust the lawn mower cutting height so that the lawn mower cuts off only the top one-third of the grass blades. If the lawn is overgrown it will be necessary to raise the height of cut to reduce pushing effort and to keep from overloading the engine and leaving clumps of mulched grass. For extremely heavy mulching, reduce your width of cut by overlapping previously cut path and mow slowly.
- Certain types of grass and grass conditions may require that an area be mulched a second time to completely hide the clippings. When doing a second cut, mow across or perpendicular to the first cut path.
- Change your cutting pattern from week to week. Mow north to south one week then change to east to west the next week. This will help prevent matting and graining of the lawn.

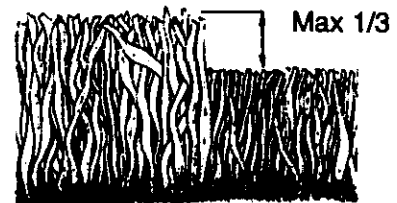



# PRODUCT SPECIFICATIONS

SERIALNUMBER	
DATE OF PURCHASE	
GASOLINE CAPACITY/ TYPE:	1.5 QUARTS UNLEADED REGULAR
OIL TYPE (API-SF/SG/SH):	SAE 30 (ABOVE 32°F) SAE 5W-30 (BELOW 32°F)
OIL CAPACITY:	20 OZS.
SPARK PLUG (GAP: .030")	CHAMPION RJ19LM OR J19LM
VALVE CLEARANCE:	INTAKE: .004 - .008 EXHAUST: .004 - .008
SOLID STATE IGNITION AIR GAP:	.0125 IN.
BLADE BOLT TORQUE:	35-40 FT. LBS.
<p>• The model and serial numbers will be found on a decal attached to the rear of the lawn mower housing. Record both serial number and date of purchase in space provided above.</p>	

## LAWNMOWER

Always observe safety rules when performing any maintenance.

### TIRES

- Keep tires free of gasoline, oil, or insect control chemicals which can harm rubber.
- Avoid stumps, stones, deep ruts, sharp objects and other hazards that may cause tire damage.

### BLADE CARE

For best results, mower blade must be kept sharp. Replace bent or damaged blades.

### TO REMOVE BLADE

- Disconnect spark plug wire from spark plug and place wire where it cannot come in contact with spark plug.
- Turn lawn mower on its side. Make sure air filter and carburetor are up.
- Use a wood block between blade and mower housing to prevent blade from turning when removing blade bolt.
- Protect your hands with gloves and/or wrap blade with heavy cloth.
- Remove blade bolt by turning counter-clockwise.
- Remove blade and attaching hardware (bolt, lock washer and hardened washer).

**NOTE:** Remove the blade adapter and check the key inside hub of blade adapter. The key must be in good condition to work properly. Replace adapter if damaged.

### TO REPLACE BLADE

- Position the blade adapter on the engine crankshaft. Be sure key in adapter and crankshaft keyway are aligned.
- Position blade on the blade adapter aligning the two (2) holes in the blade with the raised lugs on the adapter.
- Be sure the trailing edge of blade (opposite sharp edge) is up toward the engine.
- Install the blade bolt with the lock washer and hardened washer into blade adapter and crankshaft.
- Use block of wood between blade and lawn mower housing and tighten the blade bolt, turning clockwise.
- The recommended tightening torque is 35-40 ft. lbs.

**IMPORTANT:** Blade bolt is grade 8 heat treated.

### TO SHARPEN BLADE

**NOTE:** We do not recommend sharpening blade - but if you do, be sure the blade is balanced.

Care should be taken to keep the blade balanced. An unbalanced blade will cause eventual damage to lawn mower or engine.

- The blade can be sharpened with a file or on a grinding wheel. Do not attempt to sharpen while on the mower.
- To check blade balance, drive a nail into a beam or wall. Leave about one inch of the straight nail exposed. Place center hole of blade over the head of the nail. If blade is balanced, it should remain in a horizontal position. If either end of the blade moves downward, sharpen the heavy end until the blade is balanced.

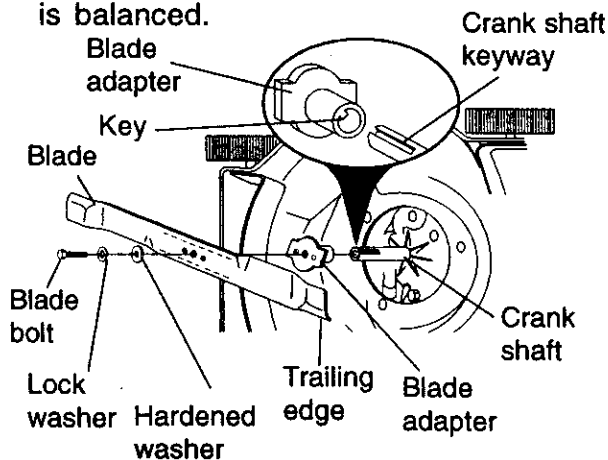

### GRASS CATCHER

- The grass catcher may be hosed with water, but must be dry when used.
- Check your grass catcher often for damage or deterioration. Through normal use it will wear. If catcher needs replacing, replace only with a manufacturer approved replacement catcher. Give the lawn mower model number when ordering.

### DRIVE WHEELS

Check front drive wheels each time before you mow to be sure they move freely. The wheels not turning freely means trash, grass cuttings, etc. are in the drive wheel area and must be cleaned to free drive wheels.

If necessary to clean the drive wheels, check both front wheels.

- Remove hubcaps, hairpin cotters and washers.
- Remove wheels from wheel adjusters.

- Remove any trash or grass cuttings from inside the dust cover, pinion and/or drive wheel gear teeth.
- Put wheels back in place.
- If after cleaning, the drive wheels do not turn freely, contact your nearest authorized service center.

### GEAR CASE

- To keep your drive system working properly, the gear case and area around the drive should be kept clean and free of trash build-up. Clean under the drive cover twice a season.
- The gear case is filled with lubricant to the proper level at the factory. The only time the lubricant needs attention is if service has been performed on the gear case.
- If lubricant is required, use only Texaco Starplex Premium 1 Grease, Part No. 750369. Do not substitute.

### ENGINE

#### LUBRICATION

Use only high quality detergent oil rated with API service classification SF, SG or SH. Select the oil's SAE viscosity grade according to your expected operating temperature.

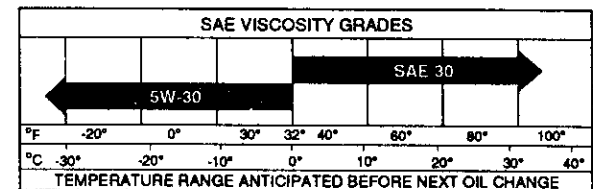

**NOTE:** Although multi-viscosity oils (5W30, 10W30 etc.) improve starting in cold weather, these multi-viscosity oils will result in increased oil consumption when used above 32°F. Check your engine oil level more frequently to avoid possible engine damage from running low on oil.

Change the oil after every 25 hours of operation or at least once a year if the lawn mower is not used for 25 hours in one year.

Check the crankcase oil level before starting the engine and after each five (5) hours of continuous use. Tighten oil plug securely each time you check the oil level.

## TO CHANGE ENGINE OIL

**NOTE:** Before tipping lawn mower to drain oil, drain fuel tank by running engine until fuel tank is empty.

- Disconnect spark plug wire from spark plug and place wire where it cannot come in contact with spark plug.
- Remove engine oil cap; lay aside on a clean surface.
- Tip lawn mower on its side as shown and drain oil into a suitable container. Rock lawn mower back and forth to remove any oil trapped inside of engine.
- Wipe off any spilled oil on lawn mower and on side of engine.
- Fill engine with oil. Fill only to the "FULL" line on the dipstick. DO NOT overfill.
- Replace engine oil cap.
- Reconnect spark plug wire to spark plug.

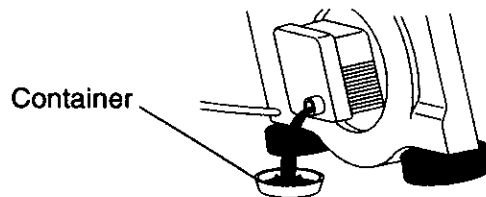

## AIR FILTER

Your engine will not run properly and may be damaged by using a dirty air filter.

Replace the air filter every year, more often if you mow in very dusty, dirty conditions. Do not wash air filter.

### TO CHANGE AIR FILTER

- Remove the air filter by turning clockwise to the stop and pull away from collar.
- Remove filter from inside of cover.
- Clean the inside of the cover and the collar to remove any dirt accumulation.
- Insert new filter into cover.
- Put air filter cover and filter into collar aligning the tab with the slot.
- Push in on cover and turn counter-clockwise to tighten.

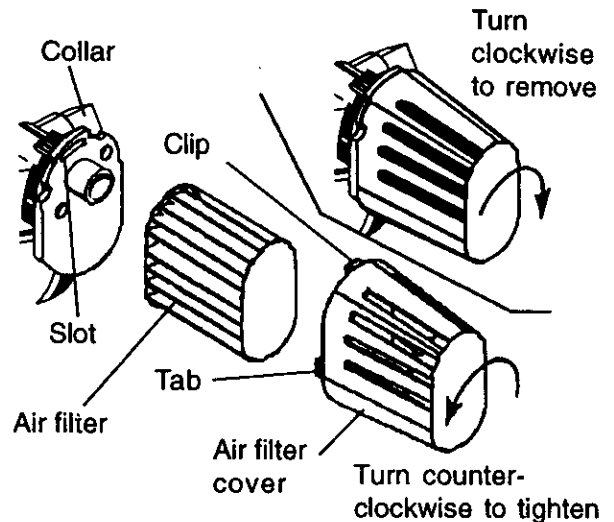

## MUFFLER

Inspect and replace corroded muffler as it could create a fire hazard and/or damage.

## SPARK PLUG

Change your spark plug each year to make your engine start easier and run better. Set spark plug gap at .030 inch.

## CLEANING

**IMPORTANT:** For best performance, keep mower housing free of built-up grass and trash. Clean the underside of your mower after each use.

**CAUTION:** Disconnect spark plug wire from spark plug and place wire where it cannot come in contact with the spark plug.

- Turn lawn mower on its side. Make sure air filter and carburetor are up. Clean the underside of your lawn mower by scraping to remove build-up of grass and trash.
- Clean engine often to keep trash from accumulating. A clogged engine runs hotter and shortens engine life.
- Keep finished surfaces and wheels free of all gasoline, oil, etc.
- We do not recommend using a garden hose to clean lawn mower unless the electrical system, muffler, air filter and carburetor are covered to keep water out. Water in engine can result in shortened engine life.

## CLEAN UNDER DRIVE COVER

Clean under drive cover at least twice a season. Scrape underside of cover with putty knife or similar tool to remove any build-up of trash or grass on underside of drive cover.

# SERVICE AND ADJUSTMENTS

**⚠ CAUTION:** Before performing any service and adjustments:

- Release control bar and stop engine.
- Make sure the blade and all moving parts have completely stopped.
- Disconnect spark plug wire from spark plug and place where it cannot come in contact with plug.

## LAWN MOWER

### TO ADJUST CUTTING HEIGHT

See "TO ADJUST CUTTING HEIGHT" in the Operation section of this manual.

### REAR DEFLECTOR

The rear deflector, attached between the rear wheels of your lawn mower, is provided to minimize the possibility that objects will be thrown out the rear of the lawn mower into the operator's mowing position. If the rear deflector becomes damaged, it should be replaced.

### TO REMOVE/REPLACE DRIVE BELT

- Remove drive cover. Remove belt by pushing down on gear case pulley and roll belt off.
- Turn lawn mower on its side with carburetor and fuel cap up.
- Remove blade.
- Remove debris shield.
- Remove belt from engine pulley on crankshaft.
- Install new belt by reversing above steps.
- Always use factory approved belt to assure fit and long life.

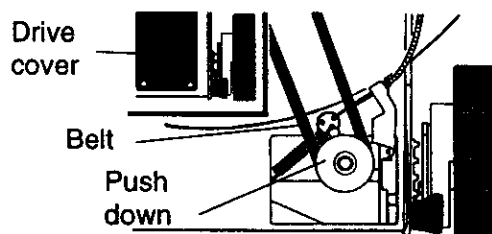

### TO ADJUST HANDLE

The upper handle may be adjusted to four (4) different height positions.

- Loosen both handle knobs only enough to allow the upper handle to pivot to the desired adjustment position..
- Tighten both handle knobs securely.

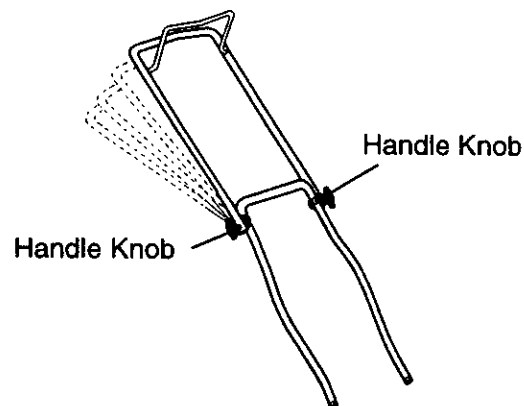

## TO ASSEMBLE GRASS CATCHER

- Put grass catcher frame into grass bag with rigid part of bag on the bottom. Make sure the frame handle is outside of the bag top.
- Slip vinyl bindings over frame.

**NOTE:** If vinyl bindings are too stiff, hold them in warm water for a few minutes. If bag gets wet, let it dry before using.

**CAUTION:** Do not run your lawn mower without clipping deflector or approved grass catcher in place. Never attempt to operate the lawn mower with the rear door removed or propped open.

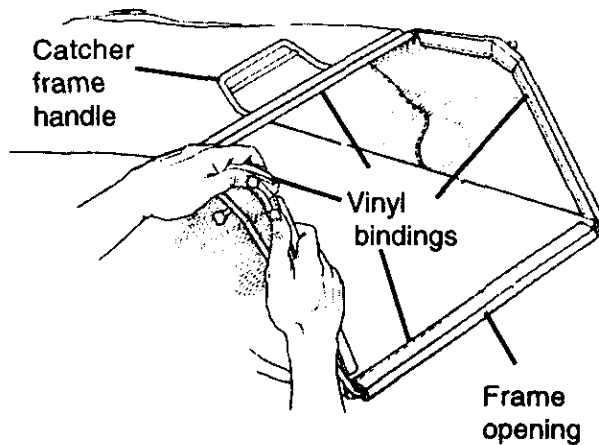

## ENGINE SPEED

Your engine speed has been factory set. Do not attempt to increase engine speed or it may result in personal injury. If you believe that the engine is running too fast or too slow, take your lawn mower to an authorized service center for repair and adjustment.

## CARBURETOR

Your carburetor has a non-adjustable fixed main jet for mixture control. If your engine does not operate properly due to suspected carburetor problems, take your lawn mower to an authorized service center for repair and/or adjustment.

**IMPORTANT:** never tamper with the engine governor, which is factory set for proper engine speed. Overspeeding the engine above the factory high speed setting can be dangerous. If you think the engine-governed high speed needs adjusting, contact your nearest authorized service center, which has proper equipment and experience to make any necessary adjustments.

# STORAGE

Immediately prepare your lawn mower for storage at the end of the season or if the unit will not be used for 30 days or more.

## LAWN MOWER

When lawn mower is to be stored for a period of time, clean it thoroughly, remove all dirt, grease, leaves, etc. Store in a clean, dry area.

- Clean entire lawn mower (See "CLEANING" in the Maintenance section of this manual).
- Lubricate as shown in the Maintenance section of this manual.
- Be sure that all nuts, bolts, screws, and pins are securely fastened. Inspect moving parts for damage, breakage and wear. Replace if necessary.
- Touch up all rusted or chipped paint surfaces; sand lightly before painting.

## HANDLE

You can fold your lawn mower handle for storage.

- Squeeze the bottom ends of the lower handle toward each other until the lower handle clears the handle bracket, then move handle forward.
- Loosen upper handle mounting bolts enough to allow upper handle to be folded back.

**IMPORTANT:** When folding the handle for storage or transportation, be sure to fold the handle as shown or you may damage the control cables.

- When setting up your handle from the storage position, the lower handle will automatically lock into the mowing position.

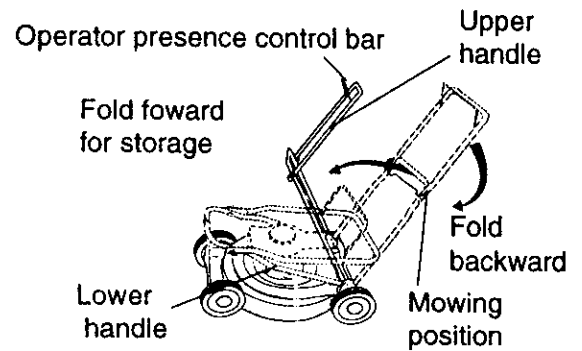
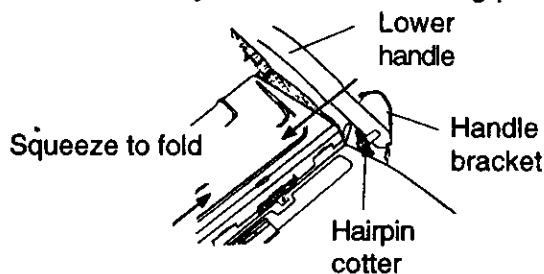

## ENGINE

### FUEL SYSTEM

**IMPORTANT:** It is important to prevent gum deposits from forming in essential fuel system parts such as carburetor, fuel filter, fuel hose or tank during storage. Also, experience indicates that alcohol blended fuels (called gasohol or using ethanol or methanol) can attract moisture which leads to separation and formation of acids during storage. Acidic gas can damage the fuel system of an engine while in storage.

- Drain the fuel tank.
- Start the engine and let it run until the fuel lines and carburetor are empty.
- Never use engine or carburetor cleaner products in the fuel tank or permanent damage may occur.
- Use fresh fuel next season.

**NOTE:** Fuel stabilizer is an acceptable alternative in minimizing the formation of fuel gum deposits during storage. Add stabilizer to gasoline in fuel tank or storage container. Always follow the mix ratio found on stabilizer container. Run engine at least 10 minutes after adding stabilizer to allow the stabilizer to reach the carburetor. Do not drain the gas tank and carburetor if using fuel stabilizer.



### ENGINE OIL

Drain oil (with engine warm) and replace with clean engine oil. (See "ENGINE" in the Maintenance section of this manual).

### CYLINDER

- Remove spark plug.
- Pour one ounce (29 ml) of oil through spark plug hole into cylinder.
- Pull starter handle slowly a few times to distribute oil.
- Replace with new spark plug.

### OTHER

- Do not store gasoline from one season to another.

- Replace your gasoline can if your can starts to rust. Rust and/or dirt in your gasoline will cause problems.
- If possible, store your unit indoors and cover it to give protection from dust and dirt.
- Cover your unit with a suitable protective cover that does not retain moisture. Do not use plastic. Plastic cannot breathe which allows condensation to form and will cause your unit to rust.

**IMPORTANT:** Never cover mower while engine and exhaust areas are still warm.

**CAUTION:** Never store the lawn mower with gasoline in the tank inside a building where fumes may reach an open flame or spark. Allow the engine to cool before storing in any enclosure.

## TROUBLESHOOTING CHART

PROBLEM	CAUSE	CORRECTION
Does not start	<ol style="list-style-type: none"><li>1. Dirty air filter.</li><li>2. Out of fuel.</li><li>3. Stale fuel.</li><li>4. Water in fuel.</li><li>5. Spark plug wire is disconnected.</li><li>6. Bad spark plug.</li><li>7. Loose blade or broken blade adapter.</li><li>8. Control bar in released position.</li><li>9. Control bar defective.</li></ol>	<ol style="list-style-type: none"><li>1. Clean/replace air filter.</li><li>2. Fill fuel tank.</li><li>3. Drain tank and refill with fresh clean fuel.</li><li>4. Drain fuel tank and carburetor and refill tank with fresh gasoline.</li><li>5. Connect wire to plug.</li><li>6. Replace spark plug.</li><li>7. Tighten blade bolt or replace blade adapter.</li><li>8. Depress control bar to handle.</li><li>9. Replace control bar.</li></ol>
Loss of power	<ol style="list-style-type: none"><li>1. Rear of lawn mower housing or cutting blade dragging in heavy grass.</li><li>2. Cutting too much grass.</li><li>3. Dirty air filter.</li><li>4. Buildup of grass, leaves, and trash under mower.</li><li>5. Too much oil in engine.</li><li>6. Walking speed too fast.</li></ol>	<ol style="list-style-type: none"><li>1. Set to "Higher Cut" position.</li><li>2. Set to "Higher Cut" position.</li><li>3. Clean/replace air filter.</li><li>4. Clean underside of mower housing.</li><li>5. Check oil level.</li><li>6. Cut at slower walking speed.</li></ol>
Poor cut – uneven	<ol style="list-style-type: none"><li>1. Worn, bent or loose blade.</li><li>2. Wheel heights uneven.</li><li>3. Buildup of grass, leaves and trash under mower.</li></ol>	<ol style="list-style-type: none"><li>1. Replace blade. Tighten blade bolt.</li><li>2. Set all wheels at same height</li><li>3. Clean underside of mower housing.</li></ol>

## TROUBLESHOOTING CHART

PROBLEM	CAUSE	CORRECTION
<b>Excessive vibration</b>	<ol style="list-style-type: none"> <li>1. Worn, bent or loose blade.</li> <li>2. Bent engine crankshaft.</li> </ol>	<ol style="list-style-type: none"> <li>1. Replace blade. Tighten blade bolt.</li> <li>2. Contact an authorized service center.</li> </ol>
<b>Starter rope hard to pull</b>	<ol style="list-style-type: none"> <li>1. Engine flywheel brake is on when control bar is released.</li> <li>2. Bent engine crankshaft.</li> <li>3. Blade adapter broken.</li> <li>4. Blade dragging in grass.</li> </ol>	<ol style="list-style-type: none"> <li>1. Depress control bar to upper handle before pulling starter rope.</li> <li>2. Contact an authorized service center.</li> <li>3. Replace blade adapter.</li> <li>4. Move lawn mower to cut grass or to hard surface.</li> </ol>
<b>Loss of drive</b>	<ol style="list-style-type: none"> <li>1. Drive wheels not turning with drive control engaged.</li> <li>2. Belt not driving</li> </ol>	<ol style="list-style-type: none"> <li>1. Adjust or replace drive control cable.</li> <li>2. Put belt on pulleys or replace belts if broken.</li> </ol>
<b>Grass catcher not filling (if so equipped)</b>	<ol style="list-style-type: none"> <li>1. Cutting height too low.</li> <li>2. Lift on blade worn off.</li> <li>3. Catcher not venting air.</li> </ol>	<ol style="list-style-type: none"> <li>1. Raise cutting height.</li> <li>2. Replace blade.</li> <li>3. Clean grass catcher.</li> </ol>
<b>Hard to push</b>	<ol style="list-style-type: none"> <li>1. Grass is too high or wheel height is too low.</li> <li>2. Rear of lawn mower housing or blade dragging in grass.</li> <li>3. Grass catcher too full.</li> <li>4. Handle height position not right for you.</li> </ol>	<ol style="list-style-type: none"> <li>1. Raise cutting height.</li> <li>2. Raise rear of lawn mower housing one (1) setting higher.</li> <li>3. Empty grass catcher.</li> <li>4. Adjust handle height to suit.</li> </ol>

# REPAIR PARTS

## ROTARY LAWN MOWER -- MODEL NO. 917.377390 GEAR CASE ASSEMBLY PART NUMBER 702511

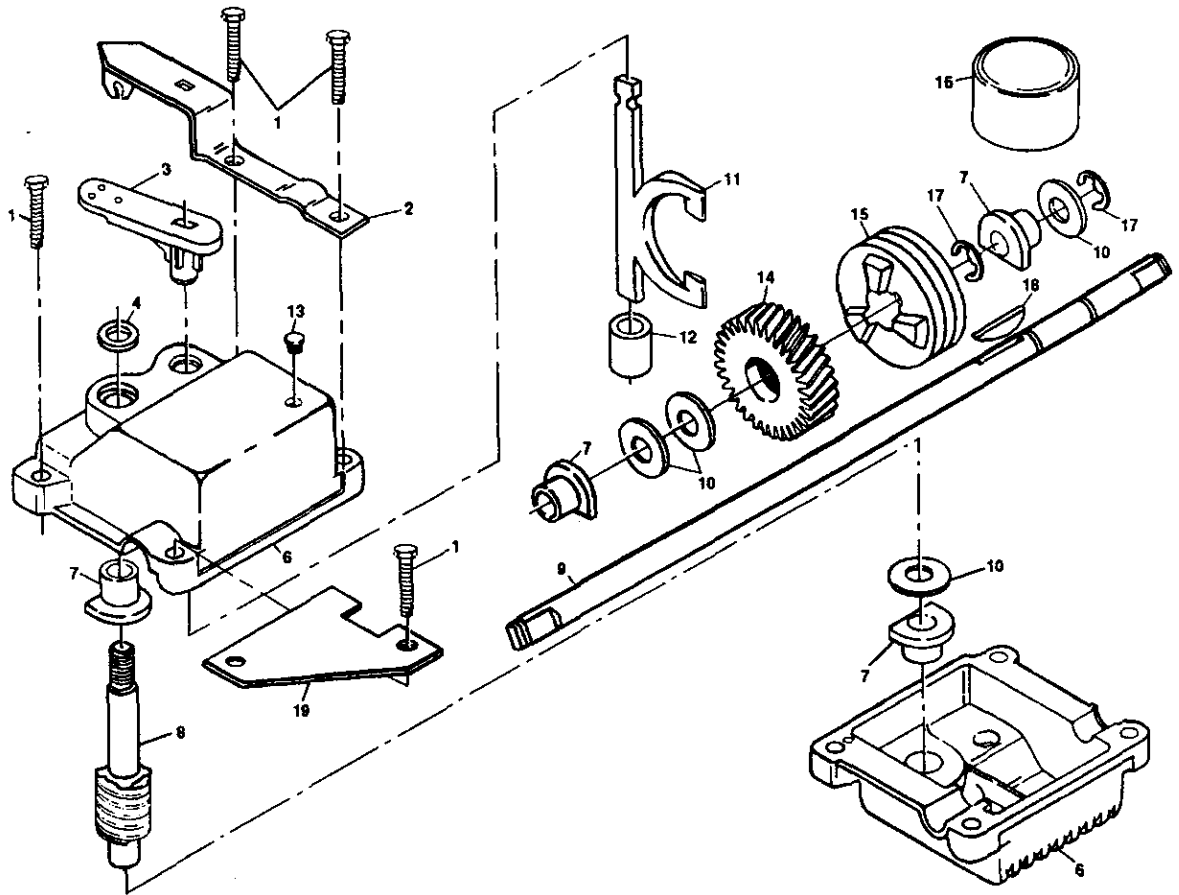

KEY NO.	PART NO.	DESCRIPTION	KEY NO.	PART NO.	DESCRIPTION
1	17490416	Tapping Screw 1/4-20 x 1-1/4	9	137074	Drive Shaft
2	137055X004	Engagement Bracket	10	57079	Hardened Washer
3	137053	Shifter	11	131484	Clutch Yoke
4	57072	Seal	12	700343	Bushing
6	48373	Gear Case Halves Kit (Includes Key Nos. 4, and 7)	13	86447	Plug
7	77881	Bearing	14	137050	Helical Gear
8	137051	Worm Shaft	15	750436X	Clutch Jaw
			16	750369	Grease
			17	12000003	E-Ring
			18	850848	Hi-Pro Key
			19	81585X004	Spring Bracket

**NOTE:** All component dimensions given in U.S. inches. 1 inch = 25.4 mm

# ROTARY LAWN MOWER MODEL NUMBER 917.377390

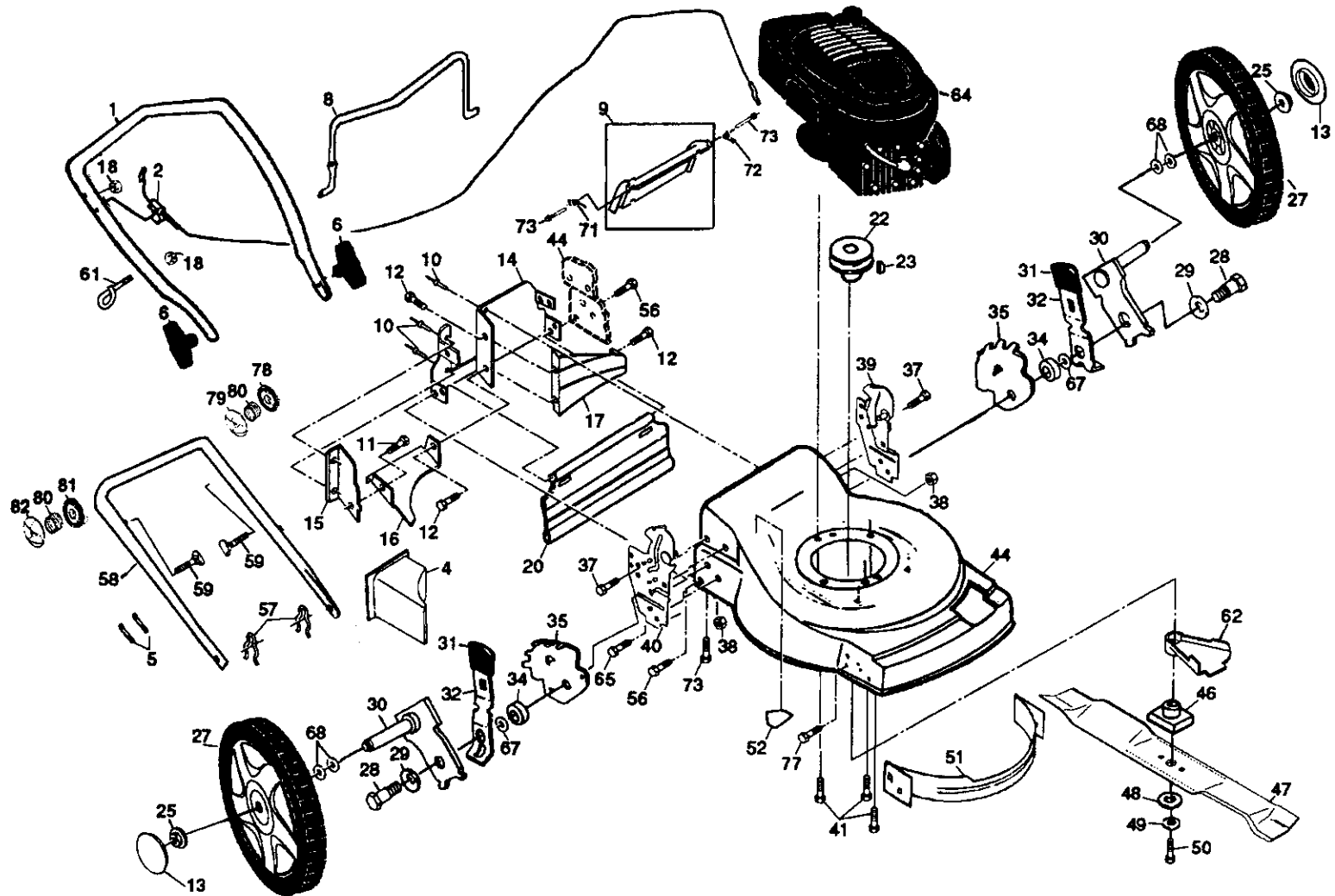

## ROTARY LAWN MOWER MODEL NUMBER 917.377390

39

KEY NO.	PART NO.	DESCRIPTION	KEY NO.	PART NO.	DESCRIPTION
1	169933X479	Upper Handle	44	172835	Lawn Mower Housing (Incl. Key #14, 15, 51 & 52)
2	164322	Engine Zone Control Cable	46	851514	Blade Adapter
4	150425	Mulcher Plug	47	141114	Blade 22"
5	66426	Wire Tie	48	851074	Hardened Washer
6	136376	Handle Knob	49	850263	Helical Washer 3/8-24 x 1-3/8 Gr. 8
8	169936	Control Bar	50	851084	Hex Head Machine Screw 3/8-24 x 1-3/8 Gr. 8
9	170947	Rear Door Kit	51	170031	Kit Baffle
10	128415	Pop Rivet	52	85463	Danger Decal
11	150050	Self Tapping Screw #10-16 x 1/2	56	88652	Hinge Screw 1/4-20 x 1-1/4
12	STD512505	Hex Tapping Screw w/Sems 1/4-20 x 1/2	57	51793	Hairpin Cotter
13	151440	Hubcap	58	151590X479	Lower Handle
14	156374X479	Back Plate	59	171407	Handle Bolt
15	700365X479	Side Baffle	61	132001	Rope Guide
16	133190X479	Discharge Baffle	62	134612	Debris Shield
17	140661X479	Rear Baffle	64	-----	Engine-Craftsman - Model No. 143.006700
18	63601	Keys Locknut 1/4-20	65	74760612	Bolt
20	140540	Rear Skirt	67	88348	Washer
22	85543	Engine Pulley	68	57143	Wave Washer
23	87677	Hi-Pro Key #505	71	170939	Spring RH
25	83923	Hex Flange Nut	72	170938	Spring LH
27	151138	Wheel	73	165912	Bolt
28	142748	Shoulder Bolt 3/8-16 x 1	77	17600406	Screw. Hx. Serrated. 1/4 x 20
29	61651	Belleville Washer	78	170954	Handle Adjuster, Outside, LH
30	750913X004	Axle Arm Assembly	79	170953	Handle Adjuster, Inside, LH
31	161961	Selector Knob	80	170554	Handle Adjuster Spring
32	170136X004	Selector Spring	81	170955	Handle Adjuster, Inside, RH
34	146630	Spacer	82	170956	Handle Adjuster, Outside, RH
35	700325X007	Wheel Adjusting Bracket (Right)	--	161058	Warning Decal (Not Shown)
37	150078	Thread Cutting Screw w/Sems 5/16-18 x 3/4	--	171574	Owner's Manual (English/Spanish)
38	751592	Nut			
39	173571X479	Handle Bracket Assembly (Left)	Available accessories not included with lawn mower:		
40	173572X479	Handle Bracket Assembly (Right)	--	D/98 33313	Clipping Deflector
41	150406	Hex Head Thread Rolling Screw 3/8-16 x 1-1/8	--	71 33623	Gas Can
			--	71 33500	Fuel Stabilizer
			--	71 33300	SAE 30W Oil (20 oz.)

# ROTARY LAWNMOWER MODEL NUMBER 917.377390

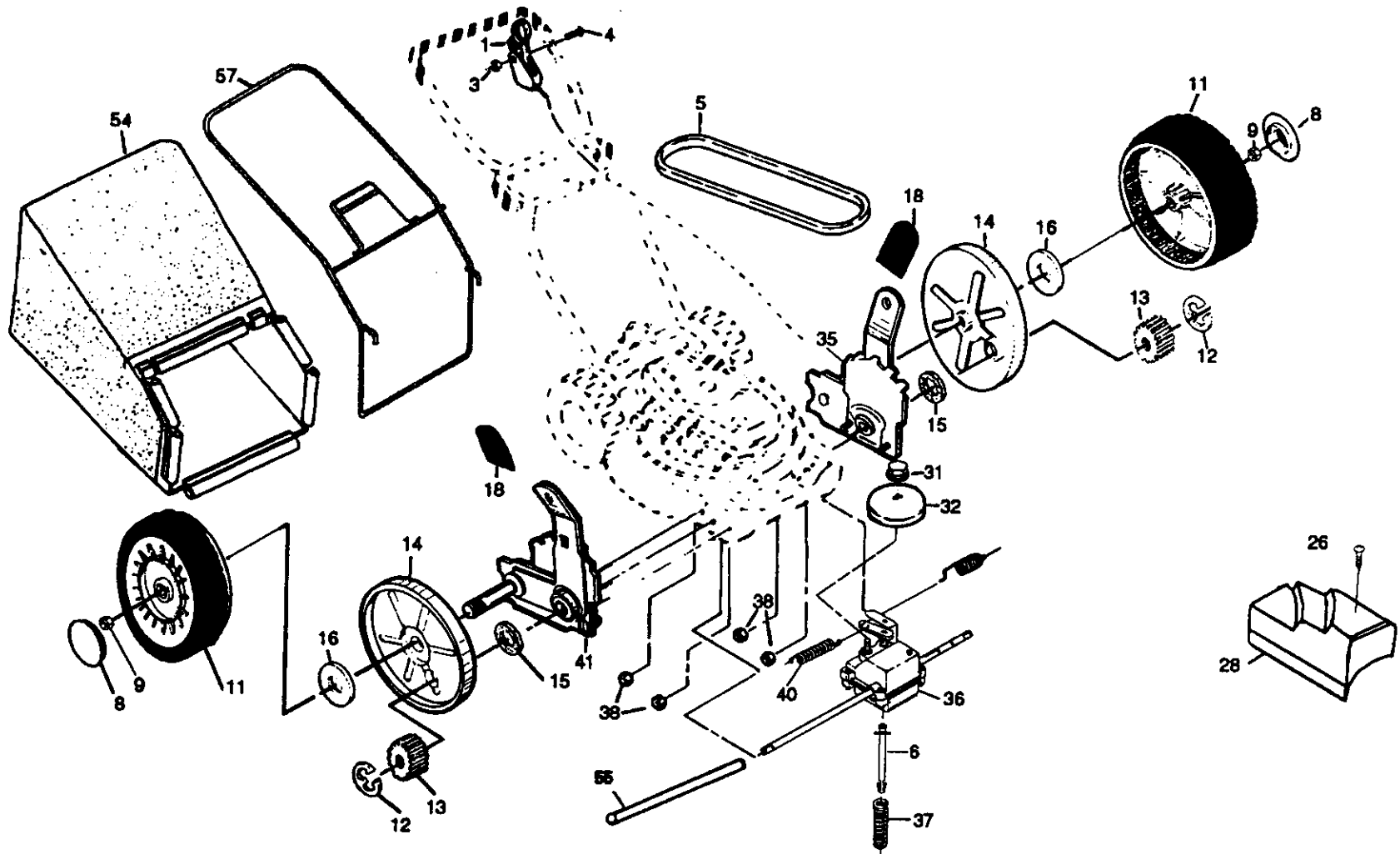

## ROTARY LAWN MOWER MODEL NUMBER 917.377390

KEY NO.	PART NO.	DESCRIPTION	KEY NO.	PART NO.	DESCRIPTION
1	146323	Control Cable Assembly	26	143603	Pan Head Tapping Screw #10-24 x 2-3/4
3	751152	Locknut #10-24	28	154990	Drive Cover
4	158755	Hex Washer Head Screw 1/4-20 x 2.12	31	132010	Hex Flange Nut
5	146527	V-Belt	32	137052	Drive Pulley
6	150495	Spring Retainer	35	151521	Wheel Adjuster Assembly (Left)
8	150182	Hubcap	36	702511	Gear Case Assembly
9	145212	Locknut	37	137090	Spring
11	150340	Wheel & Tire Assembly	38	63601	Locknut 1/4-20
12	12000058	E-Ring	40	75192	Spring
13	137054	Pinion	41	151520	Wheel Adjuster Assembly (Right)
14	88080	Dust Cover	54	169932	Grassbag Assembly
15	88118	Felt Washer	55	86012	Driveshaft Cover
16	67725	Washer 1/2 x 1-1/2 x .134	57	169931	Frame
18	701037	Selector Knob			

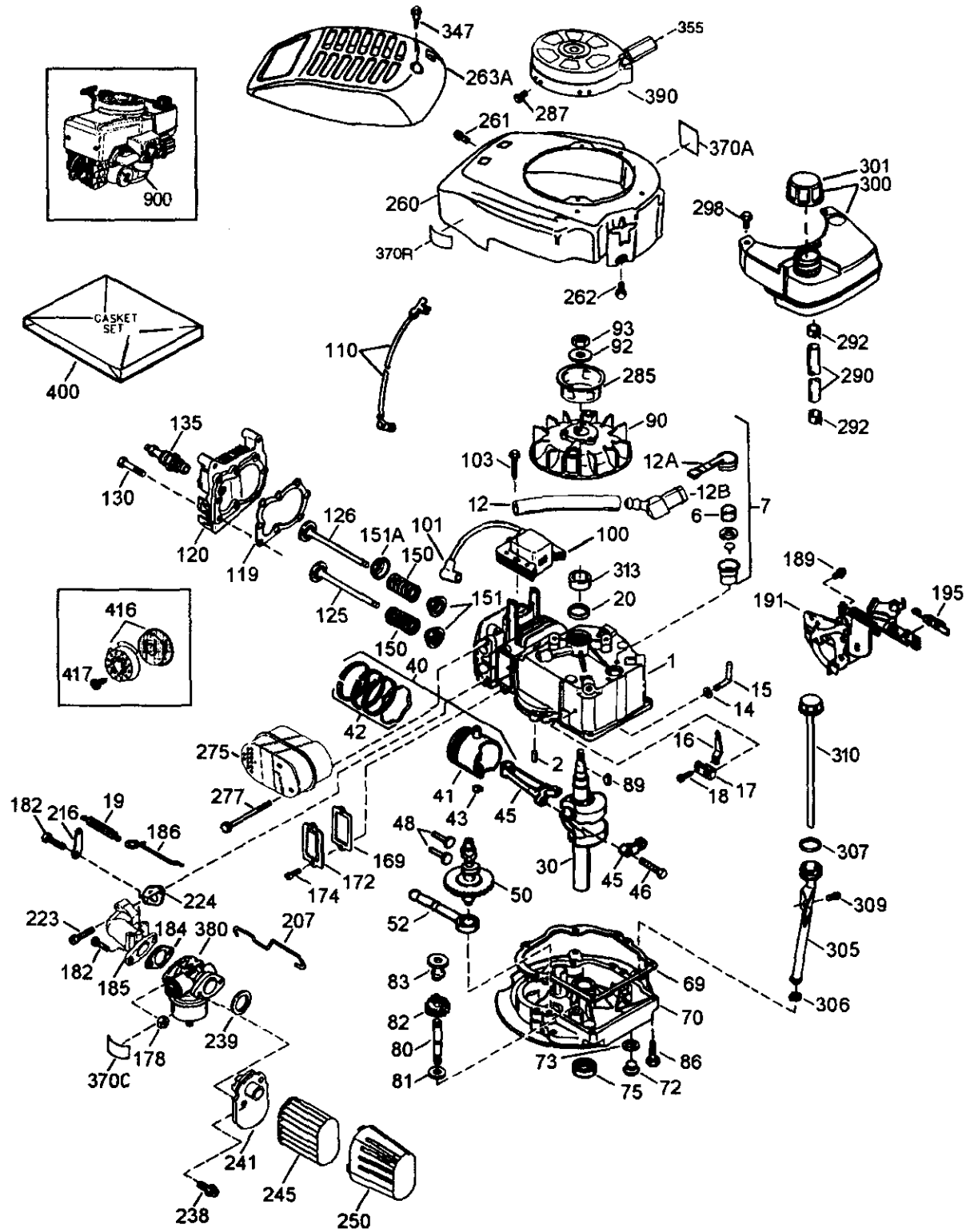



KEY NO.	PART NO.	DESCRIPTION	KEY NO.	PART NO.	DESCRIPTION
1	37465	Cylinder (Incl. 2 & 20)	174	30200	Screw, 10-24 x 9/16"
2	26727	Dowel Pin	178	29752	Nut & Lock Washer, 1/4-28
6	33734	Breather Element	182	6201	Screw, 1/4-28 x 7/8"
7	36557	Breather Ass'y. (Incl. 6 & 12A)	184	26756 *	Carburetor To Intake Pipe Gasket
12	36775	Breather Tube	185	37466	Intake Pipe
12A	36558	Breather Cover & Tube (Incl. 12B)	186	32653	Governor Link
12B	36694	Breather Tube Elbow	189	650839	Screw, 1/4-20 x 3/8"
14	28277	Washer	191	36559A	S.E. Brake Bracket (Incl. 195)
15	30589	Governor Rod (Incl. 14)	195	610973	Terminal
16	34839A	Governor Lever	207	34336	Throttle Link
17	31335	Governor Lever Clamp	216	33086	R.P.M. Adjusting Lever
18	651018	Screw, Torx T-15, 8-32 x 19/64"	223	650451	Screw, 1/4-20 x 1"
19	36281	Extension Spring	224	36786 *	Intake Pipe Gasket
20	32600	Oil Seal	238	650932	Screw, 10-32 x 49/64"
30	37464	Crankshaft	239	34338 *	Air Cleaner Gasket
40	40027	Piston, Pin & Ring Set (Std.)	241	36919	Air Cleaner Collar
41	40042	Piston & Pin Ass'y. (Std.) (Incl. 43)	245	36905	Air Cleaner Filter
42	40006	Ring Set (Std.)	250	36920	Air Cleaner Cover
43	20381	Piston Pin Retaining Ring	260	36980	Blower Housing
45	36777	Connecting Rod Ass'y. (Incl. 46)	261	30200	Screw, 10-24 x 9/16"
46	32610A	Connecting Rod Bolt	262	650831	Screw, 1/4-20 x 1/2"
48	27241	Valve Lifter	263A	37184	Starter Grill
50	37460	Camshaft (MCR)	275	37462	Muffler
52	29914	Oil Pump Ass'y.	277	650988	Screw, 1/4-20 x 2-5/16"
69	35261 *	Mounting Flange Gasket	285	35000A	Starter Cup
70	34311E	Mounting Flange (Incl. 72 thru 83)	287	650926	Screw, 8-32 x 21/64"
72	30572	Oil Drain Plug (Incl. 73)	290	29774	Fuel Line
73	28833	Drain Plug Gasket	292	26460	Fuel Line Clamp
75	27897	Oil Seal	298	28763	Screw, 10-32 x 35/64"
80	30574A	Governor Shaft	300	36916	Fuel Tank (Incl. 292 & 301)
81	30590A	Washer	301	36246	Fuel Cap
82	30591	Governor Gear Ass'y. (Incl. 81)	305	35647	Oil Fill Tube
83	30588A	Governor Spool	306	36996	"O"-Ring P
86	650488	Screw, 1/4-20 x 1-1/4"	307	35499	"O"-Ring
89	611004	Flywheel Key	309	650562	Screw, 10-32 x 1/2"
90	611112	Flywheel	310	35648	Dipstick
92	650815	Belleville Washer	313	34080	Spacer
93	650816	Flywheel Nut	347	651038	Screw, 10-32 x 51/64"
100	34443B	Solid State Ignition	355	590701	Starter Handle
101	610118	Spark Plug Cover	370A	36261	Lubrication Decal
103	651007	Screw, Torx T-15, 10-24 x 15/16"	370C	37318	Primer Decal (3 X)
110	37047	Ground Wire	370R	37317	Warning Decal
119	36787 *	Cylinder Head Gasket	380	640271	Carburetor (Incl. 184)
120	36825	Cylinder Head	390	590739	Rewind Starter
125	36779	Exhaust Valve (Std.) (Incl. 151)	400	36792B	Gasket Set (Incl. Items Marked *)
	36780	Exhaust Valve (1/32" OS) (Incl. 151)	416	36085	Spark Arrestor Kit (Incl. 417)(Optional)
126	36782	Intake Valve (1/32" OS) (Incl. 151)	417	650760	Screw, 8-32 x 3/8" (Optional)
	37289	Intake Valve (Std.) (Incl. 151)	900	— — —	Replacement Engine NONE
130	6021A	Screw, 5/16-18 x 1-1/2"	900	— — —	Replacement S/B 750859, order from 71-999
135	35395	Resistor Spark Plug (RJ19LM)	— — —	— — —	RPM High 2900 to 3200
150	31672	Valve Spring	<b>NOTE:</b> This engine could have been built with 590702 starter.		
151	31673	Valve Spring Cap	<b>NOTE:</b> All component dimensions given in U.S. inches		
151A	40017	Intake Valve Seal	1 inch = 25.4 mm		
169	36783 *	Valve Cover Gasket			
172	36784	Valve Cover			

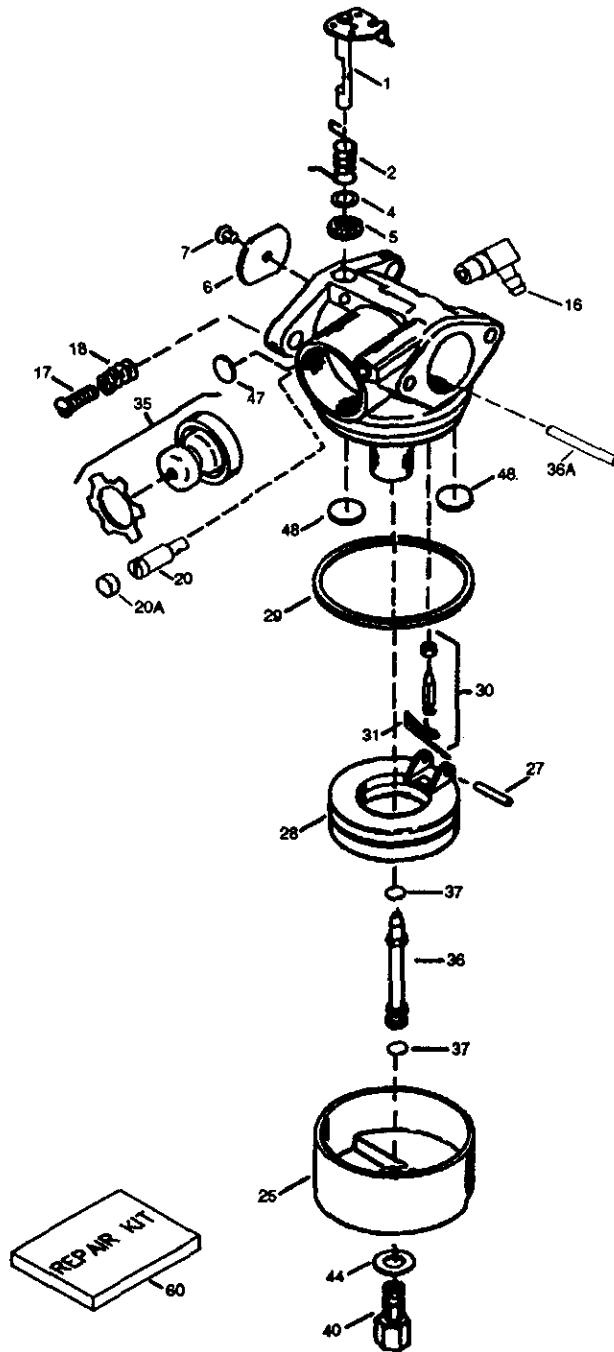

KEY NO.	PART NO.	DESCRIPTION
— —	640271	Carburetor (Incl. 184 of Engine Parts List)
1	631615	Throttle Shaft & Lever Assembly
2	631767	Throttle Return Spring
4	631184 *	Dust Seal Washer
5	631183 *	Dust Seal (Throttle)
6	640070	Throttle Shutter
7	650506 *	Shutter Screw
16	631807	Fuel Fitting
17	651025	Throttle Crack Screw/Idle Speed Screw
18	630766	Tension Spring
20	640027	Idle Restrictor Screw
20A	640200	Idle Restrictor Screw Cap (Black)
25	631867	Float Bowl
27	631024 *	Float Shaft
28	632019	Float
29	631028 *	Float Bowl "O" Ring
30	631021 *	Inlet Needle, Seat, & Clip (Incl. 31)
31	631022	Spring Clip
35	640259	Primer Bulb/Retainer Ring
36	640080	Main Nozzle Tube
36A	632766	Carburetor Tube
37	632547 *	"O" Ring, Main Nozzle Tube
40	640030	High Speed Bowl Nut
44	27110A *	Bowl Nut Washer
47	630748 *	Welch Plug, Idle Mixture Well
48	631027 *	Welch Plug, Atmospheric Vent
60	632760B	Repair kit (Incl. Items Marked *)

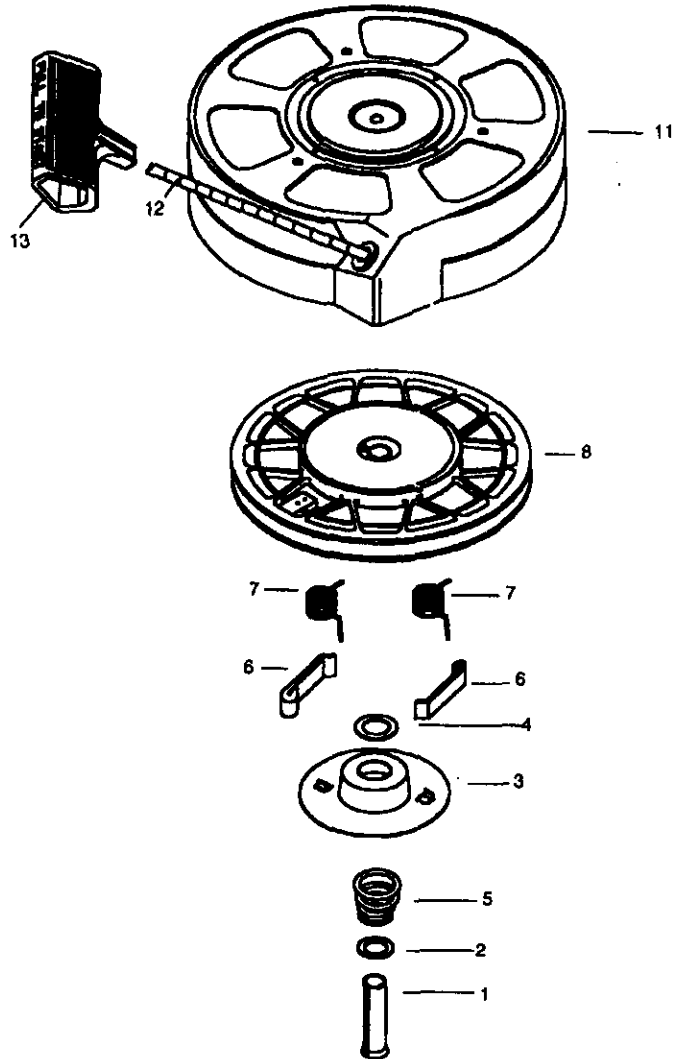

KEY NO.	PART NO.	DESCRIPTION
—	590702	Recoil Starter
1	590599A	Spring Pin (Incl. 4)
2	590600	Washer
3	590696	Retainer
4	590601	Washer
5	590697	Brake Spring
6	590698	Starter Dog
7	590699	Dog Spring
8	590700	Pulley & Rewind Spring Ass'y.
11	590703	Starter Housing Ass'y. (40 degree grommet)
12	590535	Starter Rope ( 98" X 9/64" dia.)
13	590701	Starter Handle

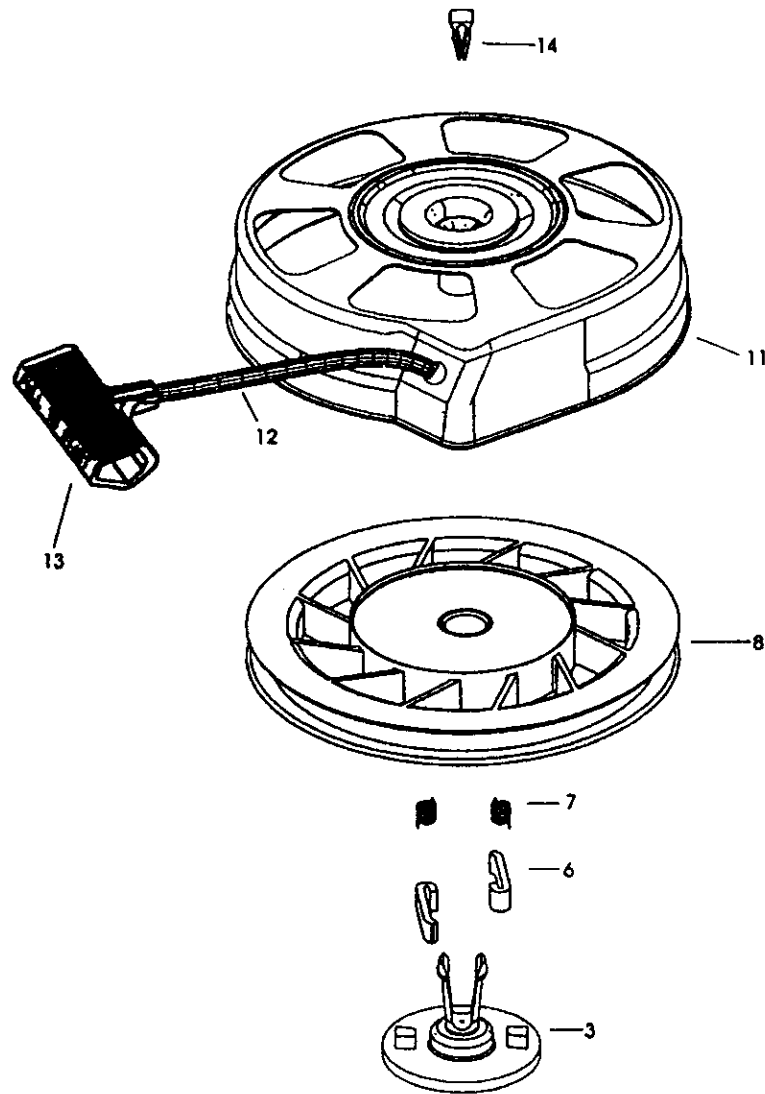

KEY NO.	PART NO.	DESCRIPTION
— —	590739	Rewind Starter
3	590740	Retainer
6	590616	Starter Dog
7	590617	Dog Spring
8	590618A	Pulley & Rewind Spring Ass'y
11	590638	Starter Housing Ass'y (40 degree grommet)
12	590535	Starter Rope (Length 98" x 9/64" dia.)
13	590701	Starter Handle
14	590760	Spring Clip

# Get it fixed, at your home or ours!

For repair of major brand appliances **in your own home...**  
no matter who made it, no matter who sold it!

**1-800-4-MY-HOME<sup>SM</sup>** Anytime, day or night  
(1-800-469-4663)

[www.sears.com](http://www.sears.com)

To bring in products such as vacuums,  
lawn equipment and electronics for repair, call for  
the location of your nearest **Sears Parts & Repair Center.**

**1-800-488-1222** Anytime, day or night

[www.sears.com](http://www.sears.com)

For the replacement parts, accessories and owner's manuals  
that you need to do-it-yourself, call **Sears PartsDirect<sup>SM</sup>**!

**1-800-366-PART** 6 a.m. – 11 p.m. CST,  
(1-800-366-7278) 7 days a week

[www.sears.com/partsdirect](http://www.sears.com/partsdirect)

To purchase or inquire about a Sears Service Agreement:

**1-800-827-6655**

7 a.m. – 5 p.m. CST, Mon. – Sat.

Para pedir servicio de reparación a domicilio,  
y para ordenar piezas con entrega a domicilio:

**1-888-SU-HOGAR<sup>SM</sup>**  
(1-888-784-6427)

Au Canada pour service en français:

**1-877-LE-FOYER<sup>SM</sup>**  
(1-877-533-6937)

