

# CRAFTSMAN®

## 25912

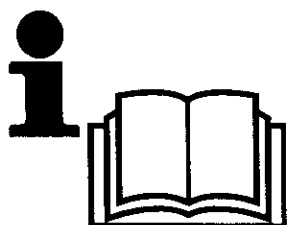
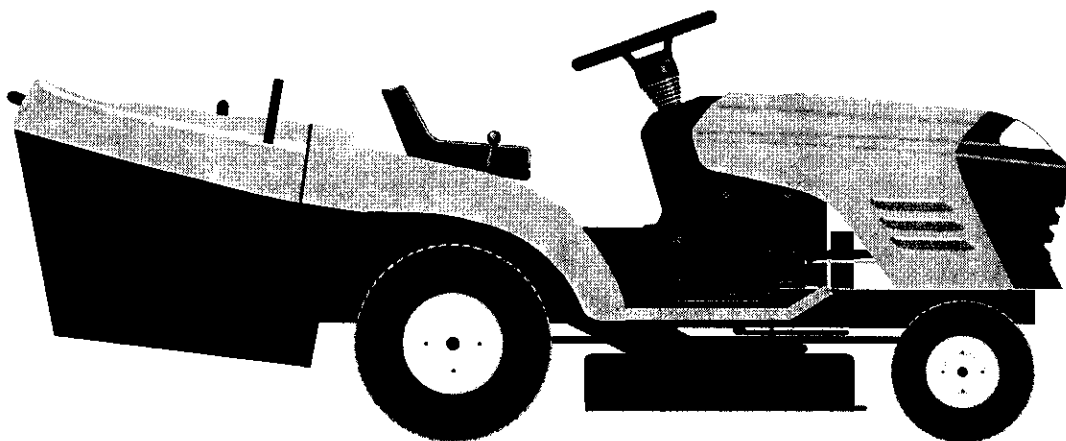

**Instruction manual**

Please read these instructions carefully and make sure you understand them before using this machine.

- 1** Safety specifications.
- 2** Assembly.
- 3** Functional description.
- 4** Procedure before start.
- 5** Driving.
- 6** Maintenance, adjustment.
- 7** Fault tracing.
- 8** Storage.

**We reserve the right to changes without prior notice.**



# 1. Safety Rules



## Safe Operation Practices for Ride-On Mowers

**IMPORTANT:** THIS CUTTING MACHINE IS CAPABLE OF AMPUTATING HANDS AND FEET AND THROWING OBJECTS. FAILURE TO OBSERVE THE FOLLOWING SAFETY INSTRUCTIONS COULD RESULT IN SERIOUS INJURY OR DEATH.

(Eng)

### I. Training

- Read the instructions carefully. Be familiar with the controls and the proper use of the equipment.
- Never allow children or people unfamiliar with the instructions to use the lawnmower. Local regulations may restrict the age of the operator.
- Never mow while people, especially children, or pets are nearby.
- Keep in mind that the operator or user is responsible for accidents or hazards occurring to other people or their property.
- All drivers should seek and obtain professional and practical instruction. Such instruction should emphasize:
  - the need for care and concentration when working with ride-on machines;
  - control of a ride-on machine sliding on a slope will not be regained by the application of the brake.

The main reasons for loss of control are:

- a) insufficient wheel grip;
- b) being driven too fast;
- c) inadequate braking;
- d) the type of machine is unsuitable for its task;
- e) lack of awareness of the effect of ground conditions, especially slopes;
- f) incorrect hitching and load distribution.

### II. Preparation

- While mowing, always wear substantial footwear and long trousers. Do not operate the equipment when barefoot or wearing open sandals.
- Thoroughly inspect the area where the equipment is to be used and remove all objects which may be thrown by the machine.
- **WARNING** - Petrol is highly flammable.
  - Store fuel in containers specifically designed for this purpose.
  - Refuel outdoors only and do not smoke while refueling.
  - Add fuel before starting the engine. Never remove the cap of the fuel tank or add petrol while the engine is running or when the engine is hot.
  - If petrol is spilled, do not attempt to start the engine but move the machine away from the area of spillage and avoid creating any source of ignition until petrol vapors have dissipated.
  - Replace all fuel tanks and container caps securely.
- Replace faulty silencers.
- Before using, always visually inspect to see that the blades, blade bolts and cutter assembly are not worn or damaged. Replace worn or damaged blades and bolts in sets to preserve balance.
- On multi-bladed machines, take care as rotating one blade can cause other blades to rotate.

### III. Operation

- Do not operate the engine in a confined space where dangerous carbon monoxide fumes can collect.
- Mow only in daylight or in good artificial light.

- Before attempting to start the engine, disengage all blade attachment clutches and shift into neutral.
- Do not use on slopes of more than 10°.
- Remember there is no such thing as a "safe" slope. Travel on grass slopes requires particular care. To guard against overturning;
  - do not stop or start suddenly when going up or downhill;
  - engage clutch slowly, always keep machine in gear, especially when traveling downhill;
  - machine speeds should be kept low on slopes and during tight turns;
  - stay alert for humps and hollows and other hidden hazards;
  - never mow across the face of the slope, unless the lawnmower is designed for this purpose.
- Use care when pulling loads or using heavy equipment.
  - Use only approved drawbar hitch points.
  - Limit loads to those you can safely control.
  - Do not turn sharply. Use care when reversing.
  - Use counterweight(s) or wheel weights when suggested in the instruction handbook.
- Watch out for traffic when crossing or near roadways.
- Stop the blades from rotating before crossing surfaces other than grass.
- When using any attachments, never direct discharge of material toward bystanders nor allow anyone near the machine while in operation.
- Never operate the lawnmower with defective guards, shields or without safety protective devices in place.
- Do not change the engine governor settings or overspeed the engine. Operating the engine at excessive speed may increase the hazard of personal injury.
- Before leaving the operator's position:
  - disengage the power take-off and lower the attachments;
  - change into neutral and set the parking brake;
  - stop the engine and remove the key.
- Disengage drive to attachments, stop the engine, and disconnect the spark plug wire(s) or remove the ignition key
  - before cleaning blockages or unclogging chute;
  - before checking, cleaning or working on the lawnmower;
  - after striking a foreign object. Inspect the lawnmower for damage and make repairs before restarting and operating the equipment;
  - if the machine starts to vibrate abnormally (check immediately).
- Disengage drive to attachments when transporting or not in use.
- Stop the engine and disengage drive to attachment
  - before refueling;
  - before removing the grass catcher;
  - before making height adjustment unless adjustment can be made from the operator's position.
- Reduce the throttle setting during engine run-out and, if the engine is provided with a shut-off valve, turn the fuel off at the conclusion of mowing.

#### **IV. Maintenance and Storage**

- Keep all nuts, bolts and screws tight to be sure the equipment is in safe working condition.
- Never store the equipment with petrol in the tank inside a building where fumes may reach an open flame or spark.
- Allow the engine to cool before storing in any enclosure.
- To reduce the fire hazard, keep the engine, silencer, battery compartment and petrol storage area free of grass, leaves, or excessive grease.
- Check the grass catcher frequently for wear or deterioration.
- Replace worn or damaged parts for safety.
- If the fuel tank has to be drained, this should be done outdoors.
- On multi-bladed machines, take care as rotating one blade can cause other blades to rotate.
- When machine is to be parked, stored or left unattended, lower the cutting means unless a positive mechanical lock is used.

 **CAUTION: Always disconnect spark plug wire and place wire where it cannot contact spark plug in order to prevent accidental starting when setting up, transporting, adjusting or making repairs.**

 These symbols may appear on your tractor or in the literature supplied with the product. Learn and understand their meaning.

**R**  
REVERSE

**N**  
NEUTRAL

**H**  
HIGH

**L**  
LOW

  
FAST

  
SLOW

  
LIGHTS ON

  
LIGHTS OFF

  
ENGINE ON

  
ENGINE OFF

  
PARKING BRAKE LOCKED

  
UNLOCKED

  
PARKING BRAKE

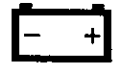
  
BATTERY

  
CLUTCH

  
CHOKE

  
FUEL

  
OIL PRESSURE

  
DIFFERENTIAL LOCK

  
REVERSE

  
FORWARD

  
IGNITION

  
ATTACHMENT  
CLUTCH ENGAGED

  
ATTACHMENT  
CLUTCH DISENGAGED

  
CAUTION

  
MOWER HEIGHT

  
BEWARE OF  
THROWN OBJECTS

Eng These symbols may appear on your tractor or in the literature supplied with the product. Learn and understand their meaning.

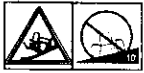

**NO OPERATION  
ON SLOPES MORE THAN 10°**



**KEEP BYSTANDERS AWAY**



**READ OWNERS MANUAL**



**EUROPEAN MACHINERY  
DIRECTIVE FOR SAFETY**



**WARNING**



**MOWER LIFT**



**DANGER, KEEP HANDS AND FEET AWAY**

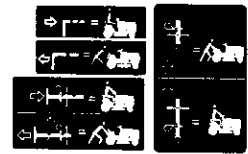

**FREE WHEEL**



**DO NOT OPERATE WITHOUT BAGGER OR DEFLECTOR**

**⚠ DANGER/POISON**

3-3908



**SHIELD EYES.**

**EXPLOSIVE GASES**  
CAN CAUSE BLINDNESS  
OR INJURY.



**NO**

- SPARKS
- FLAMES
- SMOKING



**SULFURIC ACID**

CAN CAUSE  
BLINDNESS OR  
SEVERE BURNS.

**FLUSH EYES  
IMMEDIATELY WITH  
WATER. GET MEDICAL  
HELP FAST.**



**RECYCLE**

Mfg. by/  
**EPM Products**  
Baltimore, MD 21226

MADE IN U.S.A

**KEEP OUT OF THE REACH OF CHILDREN.  
DO NOT TIP. DO NOT OPEN BATTERY!**

## 2. Assembly.

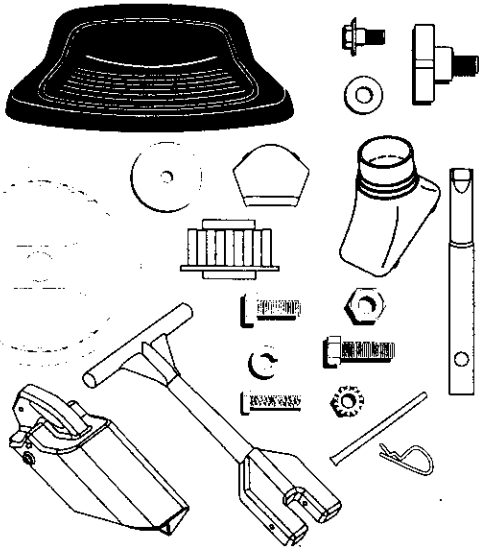

(Eng) Before the tractor can be used certain parts must be assembled, which for transportation reasons are enclosed in the packing. The picture shows which parts must be assembled.

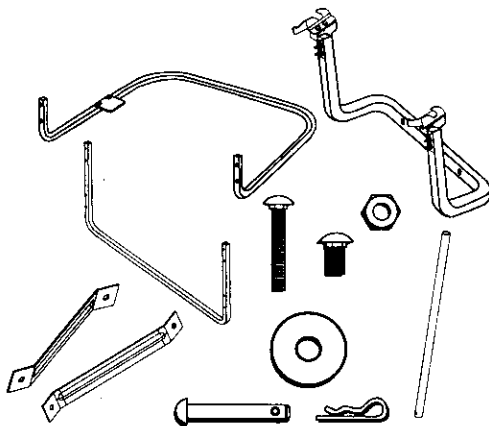

### (Eng) STEERING WHEEL

- Mount extension shaft (1). Tighten securely.
- Mount the main shaft cover. Make sure that the guide tabs in the cover fit the cover in respective holes.
- Remove steering wheel adapter from steering wheel and slide adapter onto steering shaft . Check that the front wheels are aligned forward and place the wheel on the hub.
- Assemble large flat washers, lockwasher and 3/8 hex bolt. Tighten securely.
- Snap insert into center of steering wheel.

#### 1. EXTENSION SHAFT

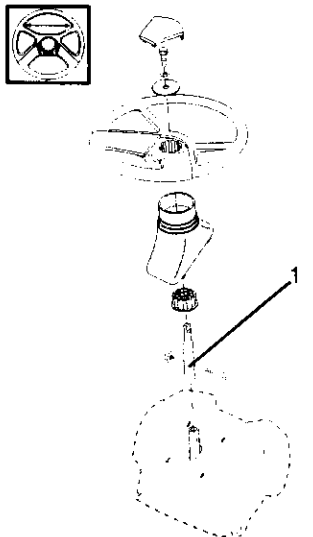



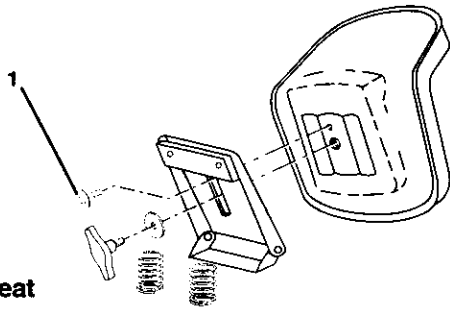

**Eng** **Seat**

Remove the hardware securing seat to the cardboard packing and set the hardware aside for assembly of seat to tractor.

Pivot seat upward and remove from cardboard packing. Remove the cardboard packing and discard.

The seat is adjustable for individual setting in relation to the clutch and brake pedal. Fold up the holder for the seat and fit the barrel screw (1).

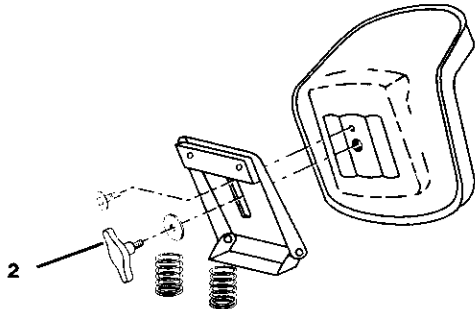

**Eng** Set the seat to the correct position by moving it forwards or backwards. Tighten the adjustment bolt securely (2).

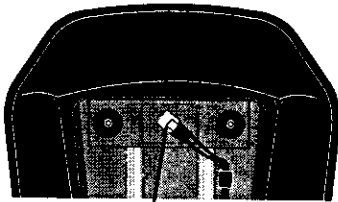

**Eng** **NOTE!**

Check that the flex is correctly connected to the safety switch (3) on the seat holder.

- Ⓔ 1. Battery Cover
- 2. Screw
- 3. Cable Positive (+)
- 4. Cable Negative (-)
- 5. Fender
- 6. Battery terminal
- 7. Battery

Ⓔ **INSTALL BATTERY**

**NOTE:** If battery is put into service after month and year indicated on label, charge battery for minimum of one hour at 6-10 amps.

**⚠ WARNING:** Before installing battery remove metal bracelets, wrist watch bands, rings, etc. from your person. Touching these items to battery could result in burns.

- Remove Battery Cover

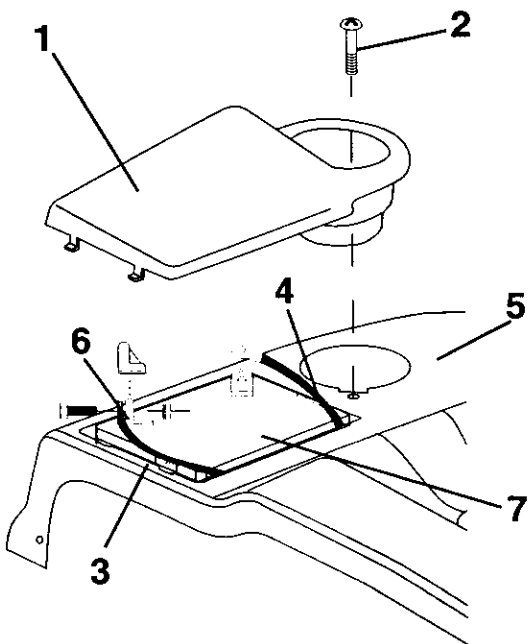

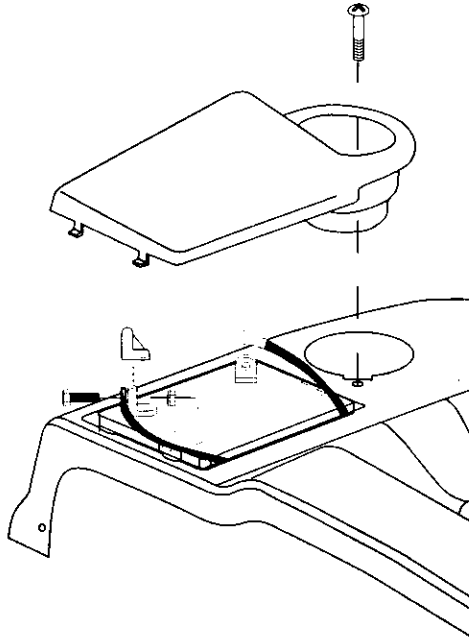

**Eng** **WARNING:** Positive terminal must be connected first to prevent sparks from accidental grounding.



Remove terminal caps and discard. Connect the red cable to + and then the black earth cable to -. Screw tight the cables. Grease the battery poles with vaseline to prevent corrosion. Replace battery cover.

# 2

**(Eng) To install bagger components to tractor**

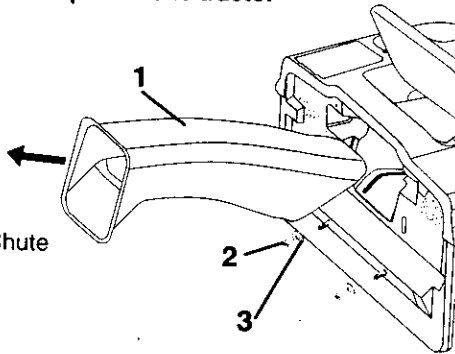

1. Discharge Chute
2. 3/8 Nut
3. Flat Washer

- Remove discharge chute from rear of tractor. Unhook the two (2) straps and pull chute out and away from tractor.
- Remove the two (2) 3/8 nuts and flat washers from the bolts at the tractor back plate.

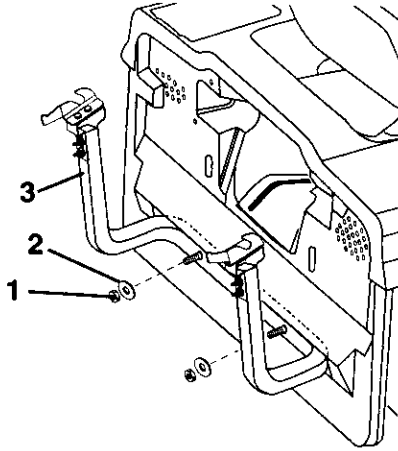

1. 3/8 Lock nut
2. Flat Washer
3. Support Tube

- Using the nuts and flat washers removed from tractor back plate, install the bagger support tube to the back plate as shown. Tighten securely.

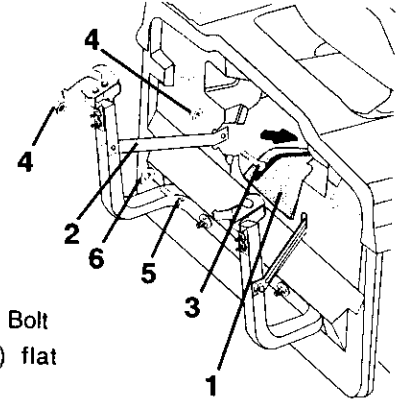

1. Rear Door
2. Support Bracket
3. 3/8 Carriage Bolt
4. 3/8 Lock Nut
5. 3/8 x 63,5mm Hex Bolt
6. 10,3mm (13/32") flat washer

- While holding the rear door open, install the two upper support brackets through the back plate and to the chassis, using the 3/8 x 19mm carriage bolts and locknuts supplied. Tighten securely.
- Assemble both support brackets to the outside of the bagger support tube using two each 3/8 x 63,5mm hex bolts 13/32" I.D. flat washers and 3/8 locknuts from parts bag. Tighten securely.

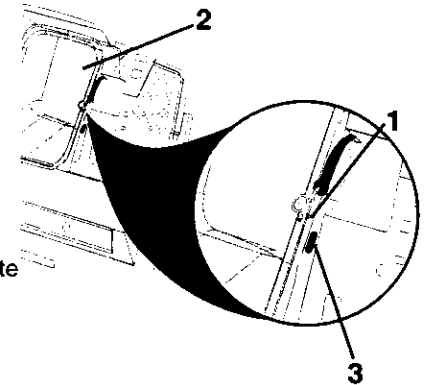

1. Hook
2. Discharge Chute
3. Back plate slot

- Replace discharge chute into rear opening of tractor. Secure the chute with the two hook straps.

**NOTE:** The strap hook must go through the discharge chute only. Do not allow the hook to enter the slot in the tractor back plate. This will allow the discharge chute to float with the mower deck when moving on uneven terrain.

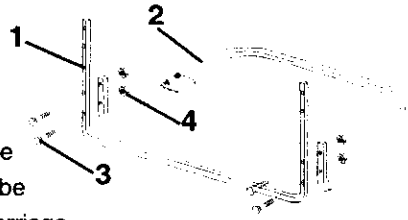

1. Front bagger tube
2. Lower bagger tube
3. 1/4 x 50,8mm Carriage Bolts
4. 1/4 Lock nut

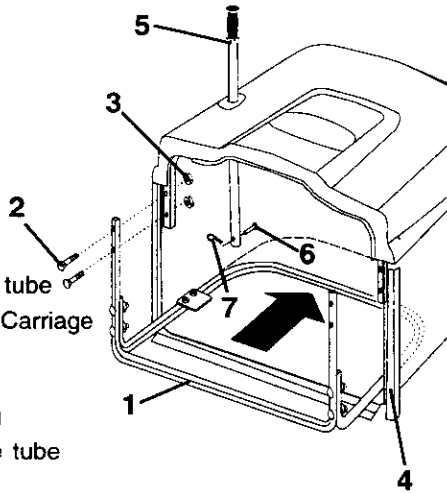

1. Front bagger tube
2. 1/4 x 50,8mm Carriage Bolts
3. 1/4 Lock nut
4. Vinyl Binding
5. Dump handle tube
6. Clevis pin
7. Retainer spring

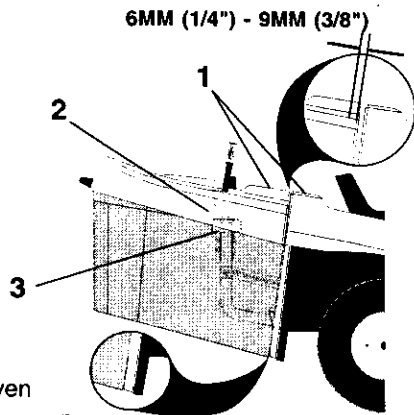

1. Top Surfaces Even
2. Horizontal Adjustment Bracket
3. Vertical Adjustment Bracket

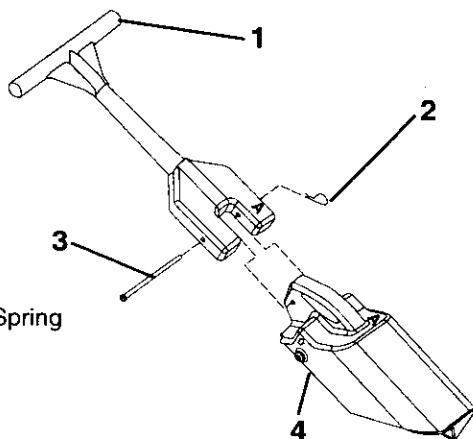

1. Handle
2. Retainer Spring
3. Pin
4. Plug

**Eng To Assemble Bagger**

**NOTE:** For ease of assembly, you may wish to obtain the assistance of another person when putting the bagger together.

- Assemble front and lower bagger tubes using four (4) 1/4 x 50,8mm carriage bolts and lock nuts supplied. Tighten securely.
- Slide front and lower bagger tube assembly into the bagger assembly.
- Assemble front and upper bagger tubes using four (4) 1/4 x 50,8mm carriage bolts and lock nuts supplied. Tighten securely.
- Slip all the vinyl bindings over the bagger tubes
- Slide the bagger dump handle through the hole in the bagger top, install the clevis pin and secure with retainer spring.

**NOTE:** For future use, the clevis pin may be removed in order to use the handle to clear the chute in the event it has become clogged.

**Bagger adjustment**

For proper bag function and appearance, it may be necessary to adjust the bagger assembly. There should be 6mm (1/4")-9mm (3/8") gap between the bagger top and fender and the bagger top surface should be even with the top surface of the fender. To adjust bagger position:

**Horizontal adjustment**

- Slightly loosen the nuts securing the bagger RH and LH horizontal adjustment brackets. Loosen only enough so the brackets keep their position, but allow them to be moved.
- Move the brackets the amount forward or backward you wish the bag assembly to move. Retighten the nuts securely.

**Vertical adjustment**

- Slightly loosen the nuts securing the vertical adjustment brackets. Loosen only enough so the brackets keep their position, but allow them to be moved.
- Move the brackets the amount up or down you wish the bag assembly to move. Retighten the nuts securely.
- Reinstall the bagger assembly and check the bagger to fender fit. If necessary, repeat the procedure until proper fit is attained.

**To convert to bagging, mulching or discharge**  
See "Section 5" of this manual.

**To assemble and install mulcher plug**

- Remove spring retainer and pin from handle.
- Insert plug into handle. Make sure that the letter "A" on both the plug and handle are on the same side and that they can both be seen from the top when laying on the ground.
- Secure with pin and retainer spring provided. For installation see "To Convert Mower" in Section 5 of this manual.

### 3. Functional description.

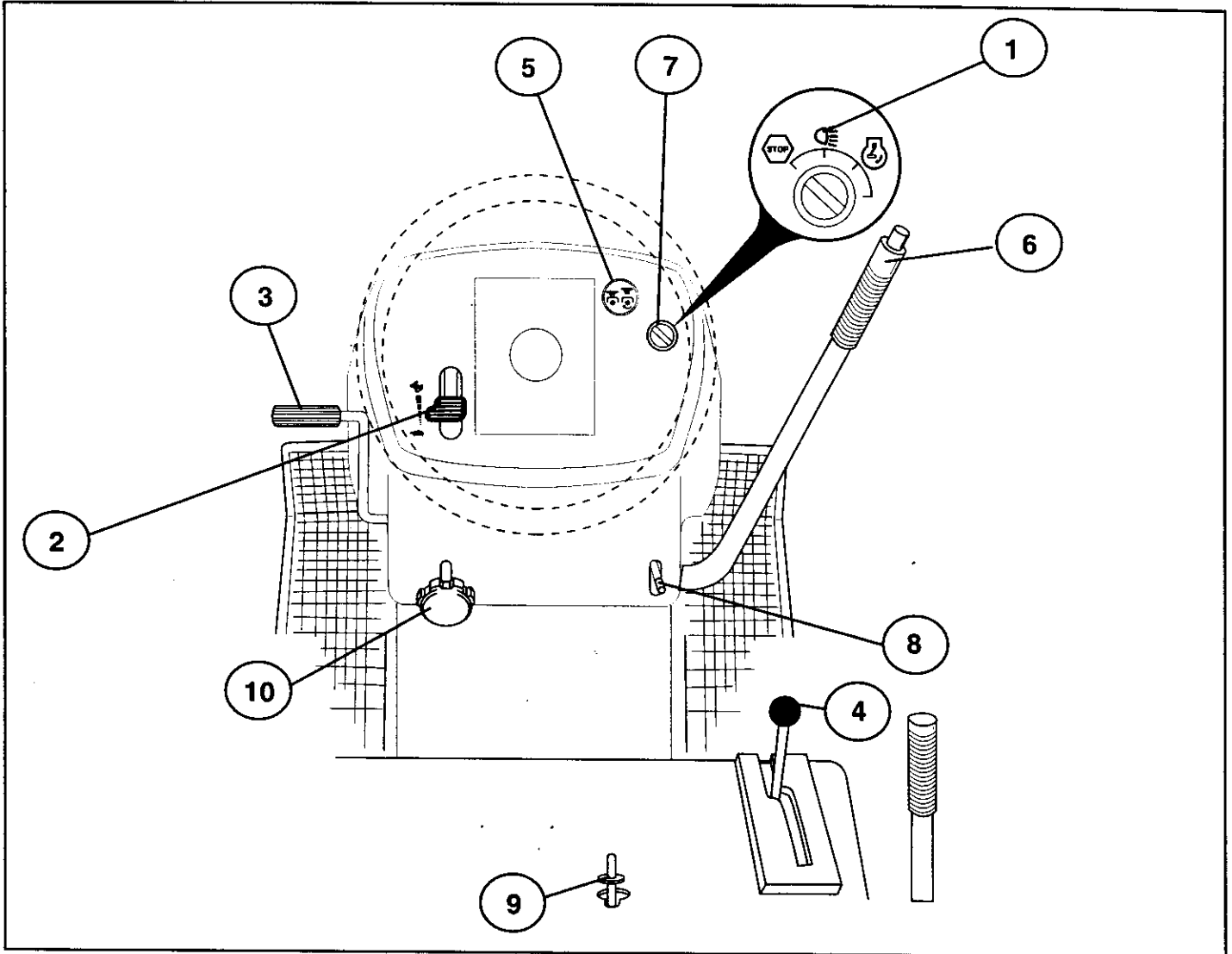

#### Eng Positioning of controls

1. Light Switch.
2. Accelerator and choke control.
3. Brake and clutch pedal.
4. Motion Control Lever.
5. Attachment clutch switch.
6. Quick lifting/lower of the cutting unit.
7. Ignition lock.
8. Parking Brake.
9. Free-wheel control lever.
10. Cutting height setting.

Eng

**1. Light switch**

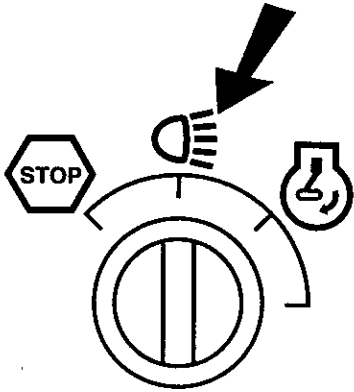

Eng

**2. Accelerator and choke control**

The accelerator control regulates the motor speed and also the speed of the blades. If the lever is in its forward position the choke function is connected. If the lever is in its reverse position the motor is in neutral. Full speed lies between these two positions.

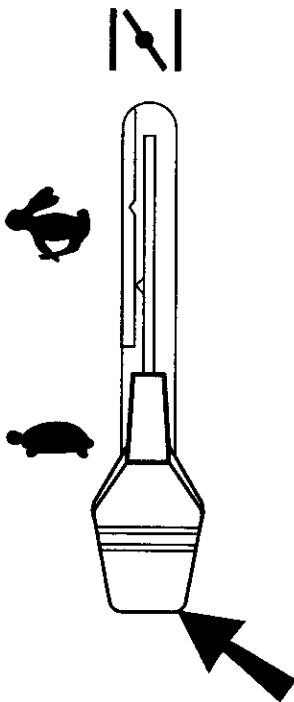

**3. Brake and clutch pedal**  
When the pedal is pushed down the brake is applied and the motor is disengaged.

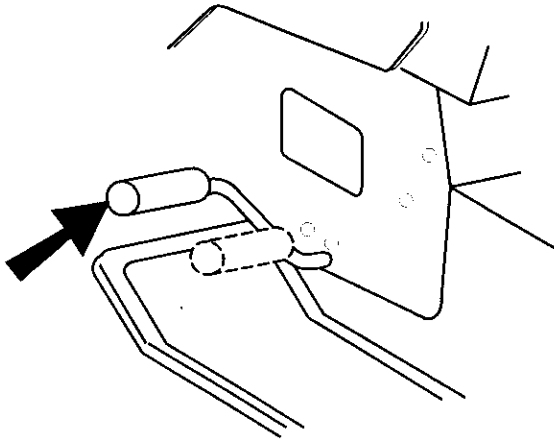



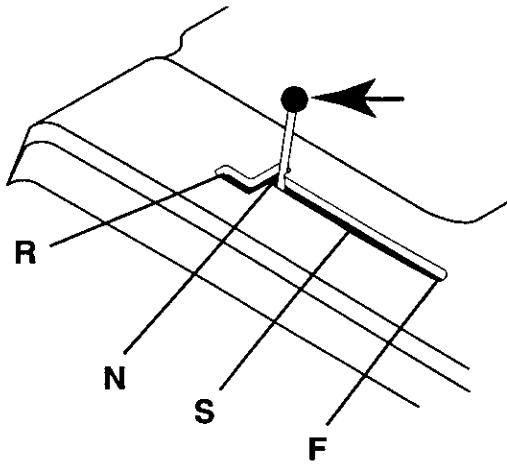

**Eng** **4. Motion control lever**

There are four different positions for this lever:

N = Neutral (no drive)

S = Slow

F = Fast

R = Reverse

The lever can be moved steplessly between S and F to ensure the required speed.

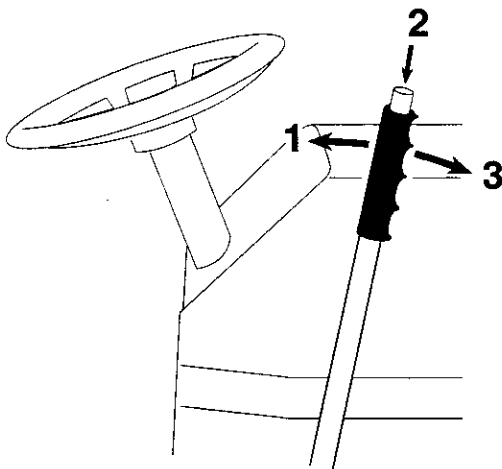
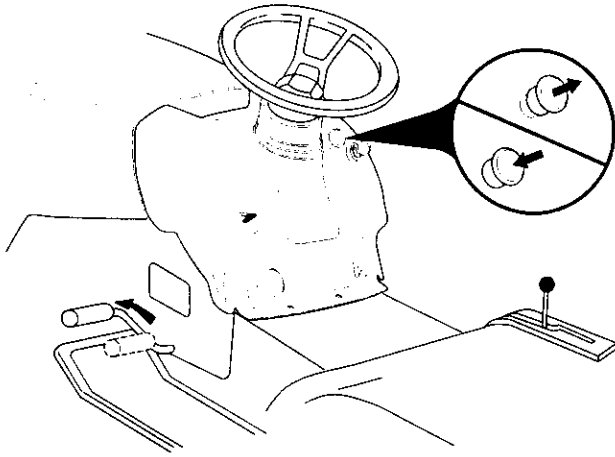
**Eng 5. Attachment clutch switch****Eng 6. Quick lifting/lowering of the cutting unit**

Pull the lever backwards to quickly lift the cutting unit when passing over irregularities in the lawn, etc. During transportation the cutting unit shall be in the highest position. Pull the lever back until it locks. To lower the unit: Pull the lever backwards (1). Push in the button (2) and then move the lever forwards (3).

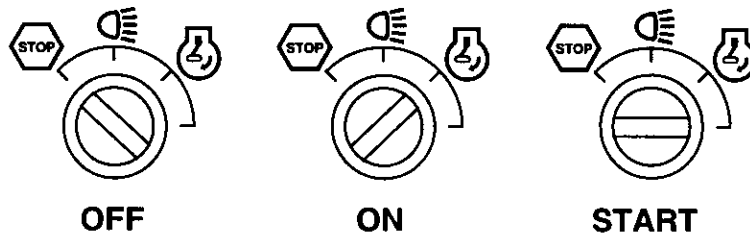

### **(Eng) 7. Ignition Lock**

There are three different positions for the ignition key:

OFF            All electric current broken.

ON             Electric current connected.

START         Start motor connected.

#### **WARNING!**

Never leave the key in the ignition lock when leaving the machine on its own.

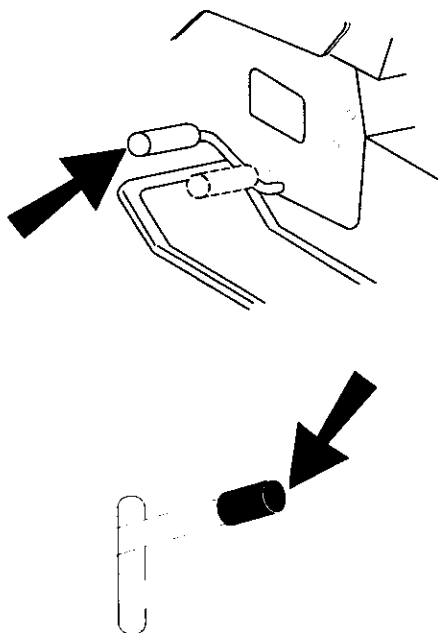

### **(Eng) 8. Parking brake**

Connect the parking brake in the following way:

1. Press down the brake pedal to bottom position.
2. Move the parking brake lever upwards and hold in this position.
3. Release the brake pedal.

To release the parking brake all that is necessary is to push down the brake pedal.

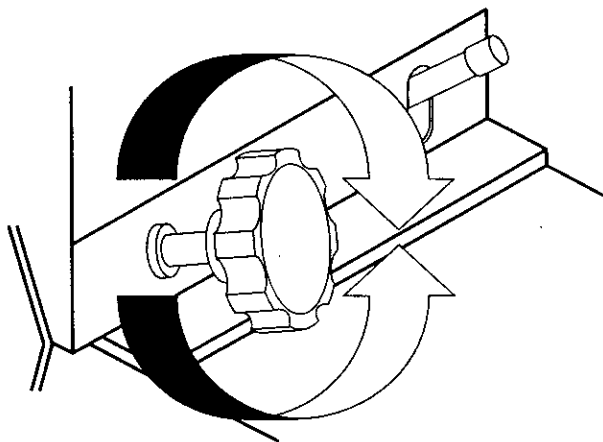

**Eng 10. Cutting height setting**

The required cutting height is set with the aid of the wheel. The cutting height is increased when it is turned clockwise. The wheel is easier to turn if the lever for lifting/lowering of the cutting unit is pulled backwards at the same time.

## 4. Before starting.

### Filling up

The engine should be run of pure (not oil mixed) unleaded petrol. Do not fill beyond the lower edge of the filling hole. Do not fill over max level.

#### **WARNING!**

Petrol is highly inflammable. Proceed with care and fill up with petrol outdoors. Do not smoke when filling with petrol or fill up when the engine is warm. Do not overfill the tank since the petrol can expand and overflow. Make sure that the petrol cap is securely tightened after filling. Store petrol in a cool place in an appropriate container for engine fuel. Check the petrol tank and pipes.

# 4

---

## **(Eng)** Oil level

The combined oil refilling cap and the oil stick is accessible when the bonnet is lifted forwards. The oil level in the engine should be checked before each run. Make sure that the tractor is horizontal. Unscrew the oil stick and wipe clean. Replace the oil stick and screw tight. Remove again and check the level.

**(Eng)** The oil level should lie between the two markings on the oil stick. If more oil is needed add SAE 30 oil to the "FULL" marking. SAE 5W-30 oil should be used during the winter (below freezing point).

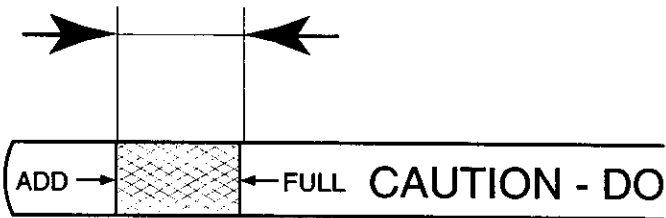

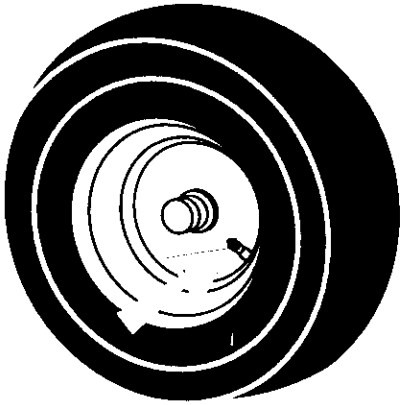
**Tire air pressure**

Check the tyre pressure regularly. The pressure in the front tyres should be 1 bar (14 PSI) and 0.8 bar (12 PSI) in the back tyres.

## 5. Driving.

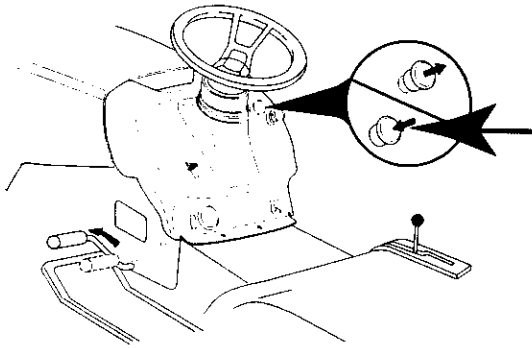

### **(Eng)** Starting of motor

Make sure that the cutting unit is in the transport position (top position) and that the lever for connection/disconnection of the cutting unit is in the disconnection position.

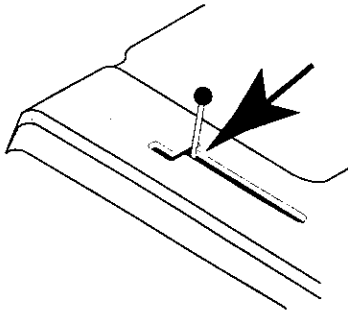

**(Eng)** Press down the clutch/brake pedal completely and hold down.  
Set the gear lever in neutral "N".

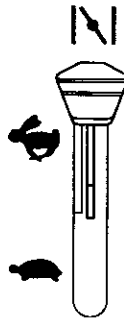

**(Eng)** Cold motor: Push the gas control up to end position choke (↑).





Eng Warm motor: Push the gas control half-way to full gass position "☞".

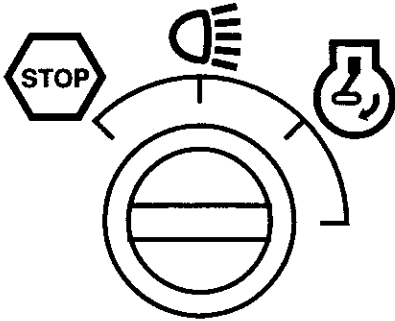

Eng Turn the ignition key to "START position".

**NOTE!**

Do not run the start motor more than 5 seconds at once. If the engine will not start, wait about 10 seconds before the next try.

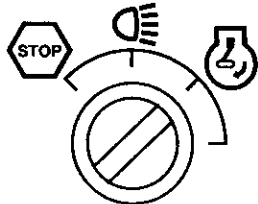

Eng Let the ignition key return to the "ON" position when the engine has started Push the gas control to the required speed. For cutting: full gas.

# 5

## **Eng** IMPORTANT! COLD STARTING FOR HYDRO

**IMPORTANT:** COLD STARTING FOR HYDRO (BELOW 40°F[4°C]) - AFTER STARTING ENGINE AND BEFORE DRIVING, LET TRANSMISSION WARM UP FOR ONE (1) MINUTE BY PLACING MOTION CONTROL LEVER IN NEUTRAL (N) POSITION AND RELEASING CLUTCH/BRAKE PEDAL.

- Start engine and move throttle control to slow position. Be sure parking brake is not engaged.
- Move motion control lever to full forward position and hold for five (5) seconds. Move lever to full reverse position and hold for five (5) seconds. Repeat this procedure three (3) times.
- Move motion control lever to neutral (N) position.
- Stop tractor by turning ignition key to "OFF" position.
- Engage transmission by placing freewheel control in driving position.
- Start engine and move throttle control to slow position.
- Drive tractor forward for approximately five feet then backwards for five feet. Repeat this driving procedure three times.
- Your tractor is now ready for normal operation.

## **Eng** PURGE TRANSMISSION

To ensure proper operation and performance, it is recommended that the transmission be purged before operating tractor for the first time. This procedure will remove any trapped air inside the transmission which may have developed during shipping of your tractor.

**IMPORTANT:** SHOULD YOUR TRANSMISSION REQUIRE REMOVAL FOR SERVICE OR REPLACEMENT, IT SHOULD BE PURGED AFTER REINSTALLATION BEFORE OPERATING THE TRACTOR.

- Park tractor on level surface so it will not roll in any direction. Parking brake must be disengaged for the following procedure.
- Disengage transmission by placing freewheel control in freewheeling position.

Eng

## NOTE!

The machine is equipped with a safety switch which immediately breaks the current to the engine if the driver leaves the seat with engine running and with the connection/disconnection lever in position "connection". Your machine is also equipped with a system that will not allow mower to operate if the bagger or optional rear discharge deflector is not installed properly.

Eng

## Driving

Lower the cutting unit by moving the lever forwards. Release the brake/clutch pedal slowly. Connect the cutting unit and move the motion control lever to the requireposition. Choose a driving speed which suits the terrain and required cutting results.

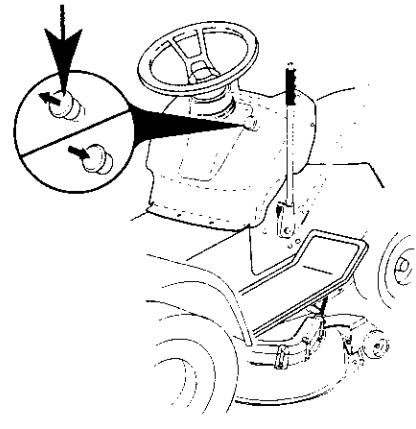

Eng

**Cutting tips**

- Clear the lawn from stones and other objects which can be thrown away by the blades.
- Localize and mark stones and other fixed objects to avoid collision.
- Begin with a high cutting height and reduce until the required cutting result is obtained.
- The cutting result is best with high engine speed (blades rotate quickly) and low gear (machine goes slowly). If the grass is too long and thick the drive speed can be increased by selecting a higher gear or reducing the motor speed, without affecting the cutting result.
- The best lawn is achieved if the grass is cut often. Cutting becomes more even and the cut grass is more evenly distributed over the surface. Total time taken is not greater, since higher drive speed can be selected without affecting the cutting results.
- Avoid cutting wet grass. The cutting results will be worse since the wheels will sink into the soft lawn.
- Spray the cutting unit with water underneath after use.

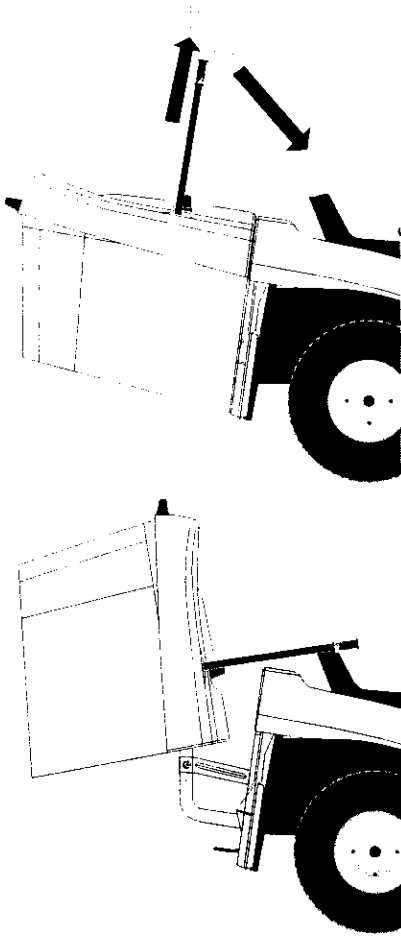

**Eng To Dump Bagger**

Your tractor is equipped with a Dump Bag Alarm. To turn off the alarm disengage the attachment clutch switch.

- Position tractor in location you wish to dump bagger.
- Place motion control lever in Neutral position and set parking brake.
- Raise dump handle to its highest position. Pull handle forward to raise bagger and dump clippings.
- To continue mowing, be sure bagger is down and in proper operating position which will allow mower to operate.

---

**Eng To convert mower**

Converting to mulching or rear discharging will require the purchase of these accessories.)

**To mulching**

- Place deck into the high cut position.
- Remove bagger or optional rear discharge deflector.
- Unhook the two (2) straps and remove discharge chute
- Insert plug and handle assembly through back plate and onto the mower deck chute adaptor.
- Retain the plug assembly by connecting the two straps over the handle and hook into the holes provided.
- Replace bagger or optional rear discharge deflector to allow mower to operate.

You are now ready to begin mulching.

**To rear discharging**

- Place deck into the high cut position.
- Remove bagger and mulching plug (if installed).
- Install discharge chute through opening in backplate and slide over deck adaptor.
- Attach the chute by hooking the two straps into the holes in the flange of the chute.
- Install the discharge deflector to the backplate by screwing the four (4) wing screws into the threaded inserts located in the backplate.
- Tighten the wing screws securely.

**To bagging**

- Place deck into the high cut position.
- Remove the rear discharge deflector or mulching plug.
- Insert the discharge chute into the opening in the backplate and onto the mower deck adaptor.
- Attach the chute to the tractor by hooking the two straps to the flange of the chute.
- Install bagger into tractor.

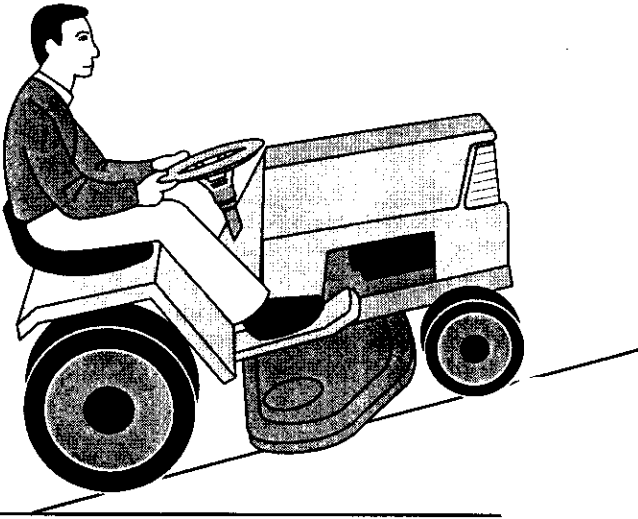

**Eng** **WARNING!**

- Do not drive in terrain at an angle of more than max. 10°. The risk for spark-over backwards is large.
- In steep terrain the risk for tipping is considerable.
- Avoid stopping and starting in sloping terrain.
- Only change gear when the machine is standing still to avoid damaging the gear box.

**Eng** Use the left side of the machine to cut close to trees, bushes and paths, etc. The blade cuts about 15 mm inside the edge of the cover.

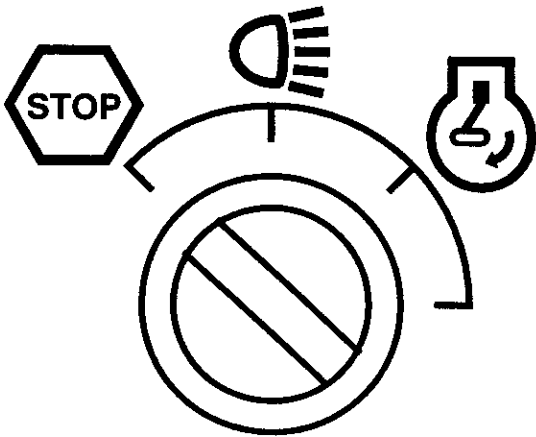

**Eng** **Switching off the engine**

Move the gas control to “”.

Disconnect the cutting unit by moving the connect/disconnect lever downwards.

Lift up the cutting unit and turn the ignition key to “OFF” position.

Allow the engine to idle for 1-2 minutes to cool down before switching off after a hard work.



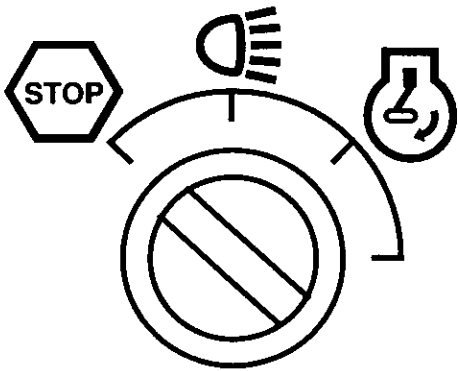

(Eng)

**WARNING!**

Do not leave the ignition key in the machine when not in use to prevent children and other unauthorized persons starting the engine.

## 6. Maintenance, adjustment.

Eng

### WARNING!

Before servicing the engine or cutting unit the following shall be carried out:

- Press down the clutch/brake pedal and engage the parking brake lever.
- Put gear lever in neutral.
- Move connection/disconnection lever to disengaged position.
- Switch off engine.
- Remove the ignition cable from the plug.

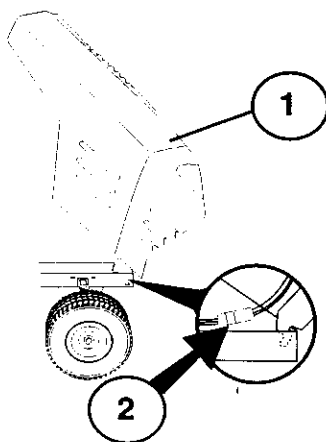

Eng

### Engine hood

- Raise hood.
- Unsnap headlight wire connector.
- Stand in front of tractor. Grasp hood at sides, tilt forward and lift off of tractor.
- To reinstall, slide hood pivot brackets into slots in frame.
- Reconnect headlight wire connector and close hood.

Eng

- (1) Hood  
(2) Headlight wire connector

# 6

(Eng)

## SERVICE RECORD

FILL IN DATES AS YOU COMPLETE REGULAR SERVICE

	As Needed	Every 8 hours	Every 25 hours	Every 50 hours	Every 100 hours	Every 200 hours
Change engine oil .....			•			
Lubricate pivot points .....			•			
Check brake operation .....	•					
Clean air screen .....		•				
Clean air filter and pre-cleaner .....		•				
Replace air cleaner paper cartridge .....					•	
Clean engine cooling fins .....				•		
Replace spark plug .....					•	
Check tire pressure .....	•					
Replace fuel filter .....						•
Clean battery and terminals .....			•			
Check muffler .....				•		
Lubricate ball joints .....					•	
Toe-in adjustment .....	•					
Carburetor adjustment .....	•					

**(Eng) Blades**

The blades should be sharp to achieve best cutting results. Sharpening can be carried out with a file or grinding disc.

**NOTE!**

It is very important that both blades are sharpened equally to avoid imbalance.

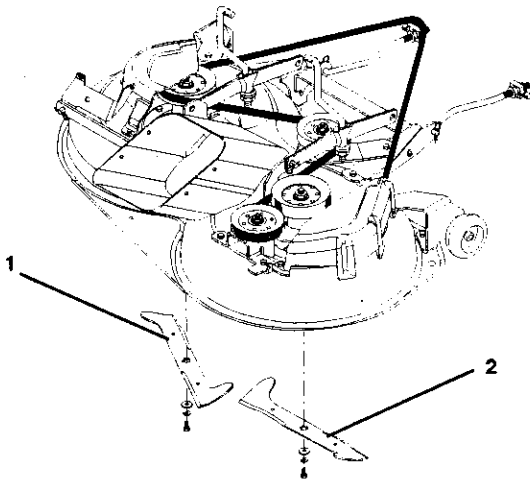

1.

(Eng) 5-Star pattern blade w/  
right hand threaded bolt

2.

(Eng) 6-Star pattern blade w/ left  
hand threaded bolt

**(Eng) Blade Care**

**Important:** The blades on your mower are not the same and must be installed on the correct side. It is suggested that you work on one blade at a time to ensure proper assembly of components.

# 6

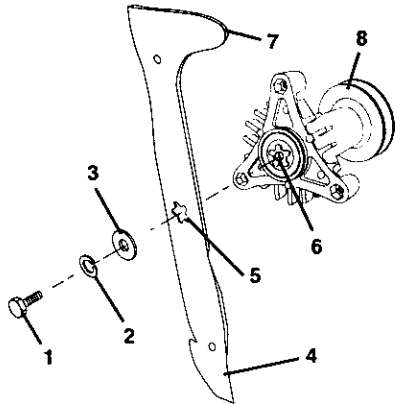

## Eng 5 Star pattern blade

The center of this blade has a five (5) star pattern. The bolt that attaches this blade has normal Right Hand threads that loosens by turning (↺) counter-clockwise and tightens by turning (↻) clockwise.

- Eng
- |                                  |                       |
|----------------------------------|-----------------------|
| 1. Hex bolt right hand threaded. | 5. 5 Star Center Hole |
| 2. Lock Washer                   | 6. 5 Star Pattern     |
| 3. Flat Washer                   | 7. Trailing Edge      |
| 4. Blade                         | 8. Mandrel Assembly   |

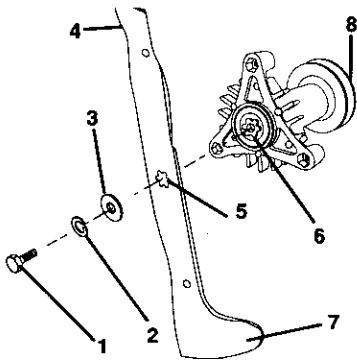

## Eng 6 Star pattern blade

The center of this blade has a 6 star pattern. The bolt attaching this blade has Left Hand threads that loosens by turning (↻) clockwise and tighten by turning (↺) counterclockwise.

- Eng
- |                                 |                       |
|---------------------------------|-----------------------|
| 1. Hex bolt left hand threaded. | 5. 6 Star Center Hole |
| 2. Lock Washer                  | 6. 6 Star Pattern     |
| 3. Flat Washer                  | 7. Trailing Edge      |
| 4. Blade                        | 8. Mandrel Assembly   |

# 6

---

**Eng** For best results mower blades must be kept sharp. Replace bent or damaged blades.

## BLADE REMOVAL

- Raise mower to highest position to allow access to blades.
- Remove hex bolt, lock washer and flat washer securing blade.
- Install new or resharpened blade with trailing edge up towards deck as shown.

**Important:** To ensure proper assembly, center hole in blade must align with star on mandrel assembly.

- Reassemble hex bolt, lock washer and flat washer in exact order as shown.
- Tighten bolt securely (27-35 Ft. Lbs. torque).

**IMPORTANT:** Blade bolt is grade 8 heat treated

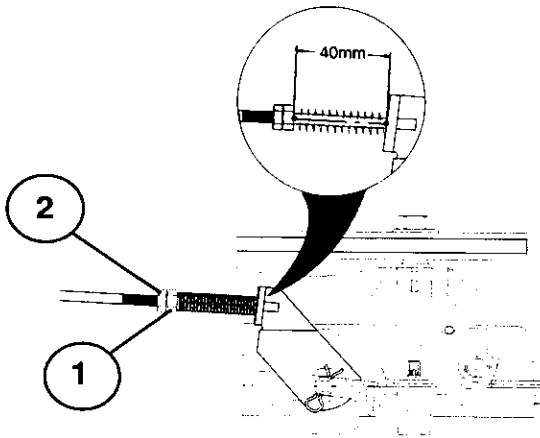

**Eng** **Brakes**

The brakes are located inside the right rear wheel. The wheel should be dismantled for best access.

1. Press down the clutch/brake pedal and engage the parking brake.

- Eng**
1. Measure the distance between the brake lever and the adjuster nut.
  2. The distance should be 40 mm (1.56").
  3. Adjust the distance if necessary by first loosening the lock nut (2) and then adjusting with the nut (1).

**WARNING!**

Do not forget to tighten the lock nut after completing adjustment.

**Eng** **Dismantling of the cutting unit**

Work from the right side of the machine.

1. Take off the belt from the engine pulley (1).
2. Remove the two rear retainer springs (2) and knock off the axle taps with a hammer.

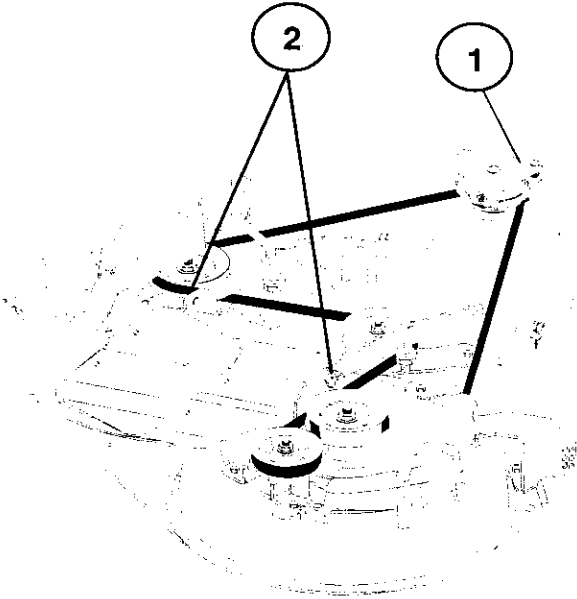



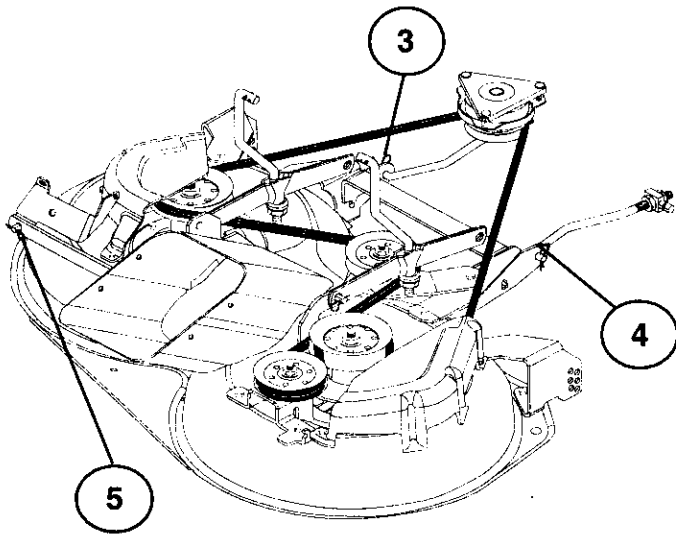

- (Eng) 3. Remove the retainer springs (3), (4), (5) and axles.
4. Pull the lever for lifting/lowering the cutting unit backwards.
5. Pull out the cutting unit from the machine.

- (Eng) **Assembly of the cutting unit**  
Assemble in the reverse order to dismantling.
- Push in the cutting unit under the machine.

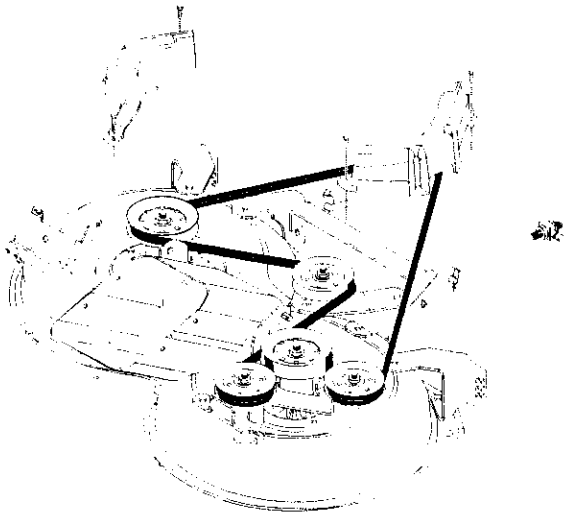

**(Eng) Replacement of drive belt for cutting unit**

1. Dismantle the cutting unit as described previously.
2. Work off the belt from the unit's left pulley and then from the other wheels.
3. Pull the belt away from the cutting unit.
4. The new belt is mounted in the reverse order. Check that the belt lies inside all the belt guides.

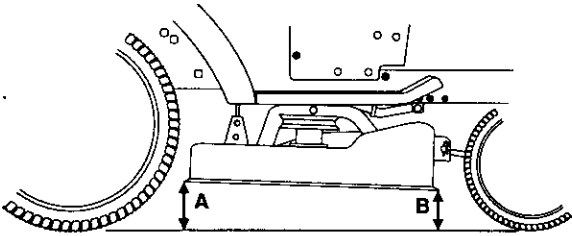

**Eng** **Adjustment of the cutting unit**

**A. In the direction of travel**

1. Check that the air pressure is correct in all four tyres.
2. Make sure that the machine is on a horizontal surface.
3. Lift up the cutting unit to its highest position.
4. Measure the distances A and B.

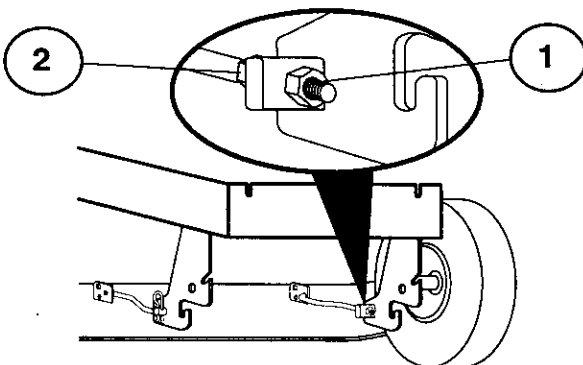

**Eng** To achieve best cutting results the cutting unit's front edge (B) should be about 10 mm (0.375") lower than the back edge (A). Adjust in the following way to raise the back edge:

1. Loosen the nut (1) on both the left and right levers.
2. Screw the nut (2) the same number of turns on both levers.
3. When the correct distance (A) is obtained this setting is locked with the nut (1).

# 6

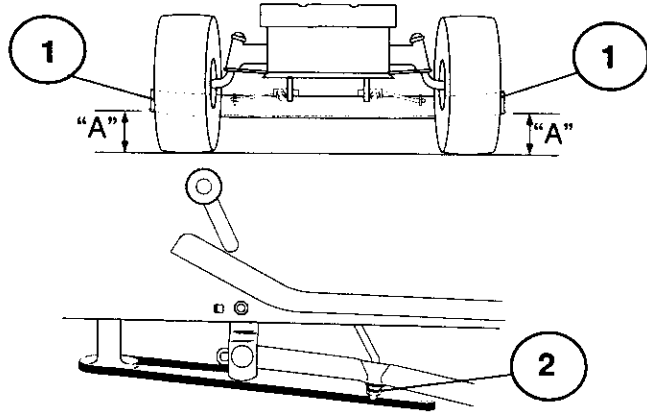

- (Eng) (1) Bottom edge of mower  
(2) Lift link adjustment nut

## (Eng) SIDE-TO-SIDE ADJUSTMENT

- Raise mower to highest position.
- At the midpoint of both sides of mower, measure height from bottom edge of mower to ground. Distance "A" should be the same or within 6mm (1/4") of each other.
- If adjustment is necessary, make adjustment on one side of mower only.
- To raise one side of mower, tighten lift link adjustment nut on that side.
- To lower one side of mower, loosen lift link adjustment nut on that side.

**NOTE:** Three full turns of adjustment nut will change mower height about 1/8".

- Recheck measurements after adjusting.

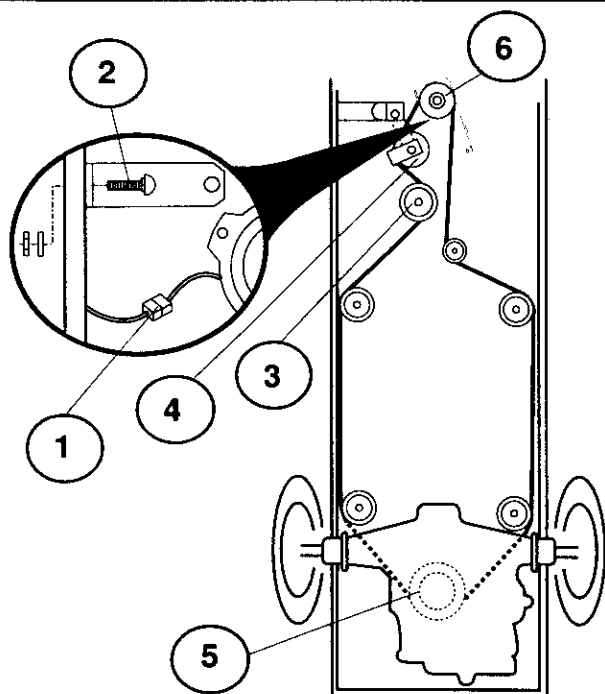

**Eng** **Replacement of drive belt**

1. Dismantle the cutting unit as described previously.
2. Pull apart the contact for the cable to the electrical connection (1).
3. Dismantle the motion restrainer for the clutch (2).
4. Engage the parking brake and work off the belt upwards from the pulley (3), the clutch pulley (4).
5. Push the belt up between two fan blades and rotate the fan clockwise until the belt comes loose (5).
6. Take off the belt from the engine pulley.

# 6

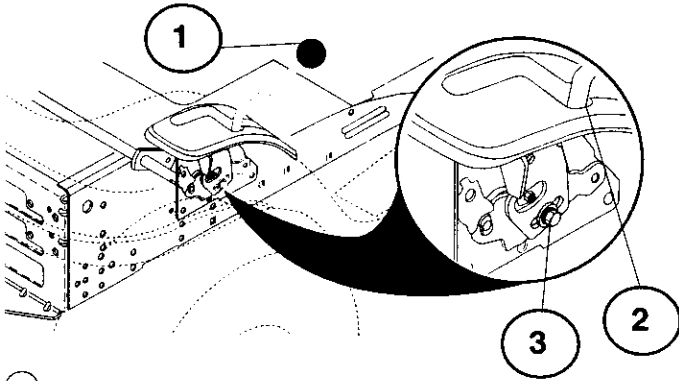

- (Eng) 1. Motion Control Lever  
2. Neutral Lock Gate  
3. Adjustment Bolt

## (Eng) TRANSAXLE MOTION CONTROL LEVER NEUTRAL ADJUSTMENT

The motion control lever has been preset at the factory and adjustment should not be necessary.

- Loosen adjustment bolt in front of the right rear wheel, and lightly tighten.
- Start engine and move motion control lever until tractor does not move forward or backward.
- Hold motion control lever in that position and turn engine off.
- While holding motion control lever in place, loosen the adjustment bolt.
- Move motion control lever to the neutral (N) (lock gate) position.
- Tighten adjustment bolt securely.

**NOTE:** If additional clearance is needed to get to adjustment bolt, move mower deck height to the lowest position. After above adjustment is made, if the tractor still creeps forward or backward while motion control lever is in neutral position, follow these steps:

- Loosen the adjustment bolt.
- Move the motion control lever 1/4 to 1/2 inch in the direction it is trying to creep.
- Tighten adjustment bolt securely.
- Start engine and test.
- If tractor still creeps, repeat above steps until satisfied.

# 6

---

## **Eng** TRANSAXLE COOLING

The fan and cooling fins of transmission should be kept clean to assure proper cooling.

Do not attempt to clean fan or transmission while engine is running or while the transmission is hot.

- Inspect cooling fan to be sure fan blades are intact and clean.
- Inspect cooling fins for dirt, grass clippings and other materials.

## **TRANSAXLE PUMP FLUID**

The transaxle was sealed at the factory and fluid maintenance is not required. Should the transaxle ever leak or require servicing, contact your nearest authorized service center/department.

## 7. Troubleshooting.

Eng

### Engine will not start

1. No fuel in fuel tank.
2. Plug defective.
3. Plug connection defective.
4. Dirt in carburettor or fuel pipe.

### Start motor will not turn engine

1. Battery flat.
2. Poor contact between cable and battery pole.
3. Connection/disconnection level in wrong position.
4. Main fuse defective.
5. Ignition lock defective.
6. Safety contact for clutch/brake pedal defective.
7. Clutch/brake pedal not pushed down.

### Engine runs unevenly

1. Gear too high.
2. Plug defective.
3. Carburettor incorrectly set.
4. Air filter blocked.
5. Fuel tank ventilation blocked.
6. Ignition setting defective.
7. Dirt in fuel pipe.

### Engine feels weak

1. Air filter blocked.
2. Plug defective.
3. Dirt in carburettor or fuel pipe.
4. Carburettor incorrectly set.

### Engine overheats

1. Engine overloaded.
2. Air inlet or cooling fins blocked.
3. Fan damaged.
4. Too little or no oil in engine.
5. Ignition setting defective.
6. Plug defective.

### Battery does not charge

1. Fuse defective.
2. One or several cells defective.
3. Poor contact between battery poles and cables.

### Lighting does not function

1. Bulbs defective.
2. Switch defective.
3. Short-circuit in cable.

### The machine vibrates

1. Blades loose.
2. Engine loose.
3. Unbalance in one or both blades resulting from damage or poor balancing after sharpening.

### Uneven cutting results

1. Blades blunt.
2. Cutting unit skew.
3. Long or wet grass.
4. Grass stuck under cover.
5. Different air pressures in tyres on left and right side.
6. Gear too high.
7. Drive belt slipping.



## 8. Storage.

(Eng) The following steps should be taken when mowing season is over:

- Clean the entire machine, especially underneath the cutting unit cover.
- Touch up all chipped paint surfaces in order to avoid corrosion.
- Change engine oil.
- Drain the fuel tank. Start the engine and allow it to run until it is out of fuel.
- Remove the spark plug and pour one table spoon of engine oil into the cylinder. Pull the engine over in order to distribute the oil. Return the spark plug.
- Remove the battery. Recharge and store it in a cool, dry place. Protect the battery from low temperatures.
- The machine should be stored indoors in a dry, dust-free place.

### **WARNING!**

Never use gasoline when cleaning. Use degreasing detergent and warm water instead.

### **Service**

When ordering, we need the following information:

Date of purchase, model, type and serial number of the mower. Always use original spare parts. Contact your local dealer of distributor for warranty service and repairs.

