

CRAFTSMAN®

25907

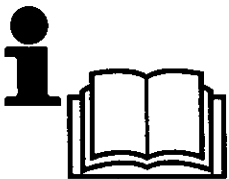
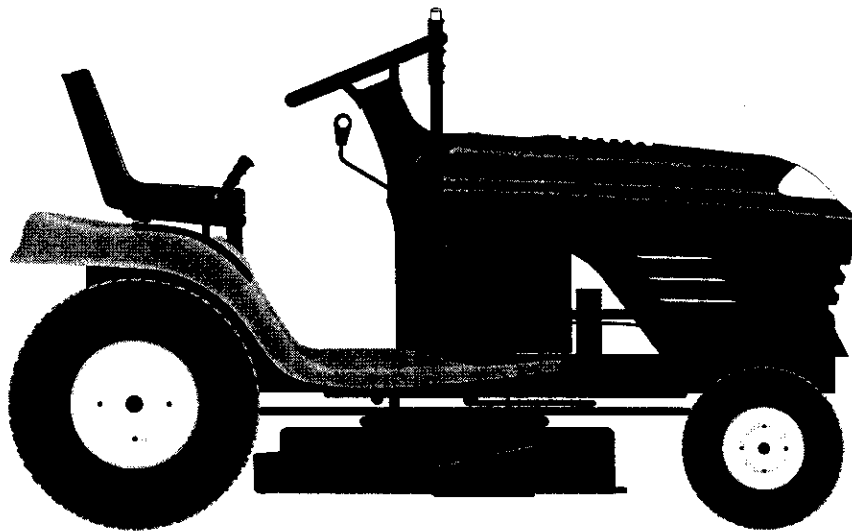

Instruction manual

Please read these instructions carefully and make sure you understand them before using this machine.

- 1** Safety specifications.
Sicherheitsbestimmungen.
Consignes de sécurité. _____
- 2** Assembly.
Zusammenbau.
Montage. _____
- 3** Functional description.
Funktionsbeschreibung.
Description du fonctionnement. _____
- 4** Procedure before start.
Maßnahmen vor dem Anlassen.
Avant de démarrer. _____
- 5** Driving.
Betrieb.
Conduite. _____
- 6** Maintenance, adjustment.
Instandhaltung, Einstellung.
Entretien, réglages. _____
- 7** Fault tracing.
Störungssuche.
Recherche des pannes. _____
- 8** Storage.
Aufbewahrung.
Rangement. _____

We reserve the right to changes without prior notice.



1. Safety Rules



Safe Operation Practices for Ride-On Mowers

IMPORTANT: THIS CUTTING MACHINE IS CAPABLE OF AMPUTATING HANDS AND FEET AND THROWING OBJECTS. FAILURE TO OBSERVE THE FOLLOWING SAFETY INSTRUCTIONS COULD RESULT IN SERIOUS INJURY OR DEATH.

(Eng)

I. Training

- Read the instructions carefully. Be familiar with the controls and the proper use of the equipment.
- Never allow children or people unfamiliar with the instructions to use the lawnmower. Local regulations may restrict the age of the operator.
- Never mow while people, especially children, or pets are nearby.
- Keep in mind that the operator or user is responsible for accidents or hazards occurring to other people or their property.
- All drivers should seek and obtain professional and practical instruction. Such instruction should emphasize:
 - the need for care and concentration when working with ride-on machines;
 - control of a ride-on machine sliding on a slope will not be regained by the application of the brake.

The main reasons for loss of control are:

- a) insufficient wheel grip;
- b) being driven too fast;
- c) inadequate braking;
- d) the type of machine is unsuitable for its task;
- e) lack of awareness of the effect of ground conditions, especially slopes;
- f) incorrect hitching and load distribution.

II. Preparation

- While mowing, always wear substantial footwear and long trousers. Do not operate the equipment when barefoot or wearing open sandals.
- Thoroughly inspect the area where the equipment is to be used and remove all objects which may be thrown by the machine.
- **WARNING** - Petrol is highly flammable.
 - Store fuel in containers specifically designed for this purpose.
 - Refuel outdoors only and do not smoke while refueling.
 - Add fuel before starting the engine. Never remove the cap of the fuel tank or add petrol while the engine is running or when the engine is hot.
 - If petrol is spilled, do not attempt to start the engine but move the machine away from the area of spillage and avoid creating any source of ignition until petrol vapors have dissipated.
 - Replace all fuel tanks and container caps securely.
- Replace faulty silencers.
- Before using, always visually inspect to see that the blades, blade bolts and cutter assembly are not worn or damaged. Replace worn or damaged blades and bolts in sets to preserve balance.
- On multi-bladed machines, take care as rotating one blade can cause other blades to rotate.

III. Operation

- Do not operate the engine in a confined space where dangerous carbon monoxide fumes can collect.
- Mow only in daylight or in good artificial light.

- Before attempting to start the engine, disengage all blade attachment clutches and shift into neutral.
- Do not use on slopes of more than 10°.
- Remember there is no such thing as a "safe" slope. Travel on grass slopes requires particular care. To guard against overturning;
 - do not stop or start suddenly when going up or downhill;
 - engage clutch slowly, always keep machine in gear, especially when traveling downhill;
 - machine speeds should be kept low on slopes and during tight turns;
 - stay alert for humps and hollows and other hidden hazards;
 - never mow across the face of the slope, unless the lawnmower is designed for this purpose.
- Use care when pulling loads or using heavy equipment.
 - Use only approved drawbar hitch points.
 - Limit loads to those you can safely control.
 - Do not turn sharply. Use care when reversing.
 - Use counterweight(s) or wheel weights when suggested in the instruction handbook.
- Watch out for traffic when crossing or near roadways.
- Stop the blades from rotating before crossing surfaces other than grass.
- When using any attachments, never direct discharge of material toward bystanders nor allow anyone near the machine while in operation.
- Never operate the lawnmower with defective guards, shields or without safety protective devices in place.
- Do not change the engine governor settings or overspeed the engine. Operating the engine at excessive speed may increase the hazard of personal injury.
- Before leaving the operator's position:
 - disengage the power take-off and lower the attachments;
 - change into neutral and set the parking brake;
 - stop the engine and remove the key.
- Disengage drive to attachments, stop the engine, and disconnect the spark plug wire(s) or remove the ignition key
 - before cleaning blockages or unclogging chute;
 - before checking, cleaning or working on the lawnmower;
 - after striking a foreign object. Inspect the lawnmower for damage and make repairs before restarting and operating the equipment;
 - if the machine starts to vibrate abnormally (check immediately).
- Disengage drive to attachments when transporting or not in use.
- Stop the engine and disengage drive to attachment
 - before refueling;
 - before removing the grass catcher;
 - before making height adjustment unless adjustment can be made from the operator's position.
- Reduce the throttle setting during engine run-out and, if the engine is provided with a shut-off valve, turn the fuel off at the conclusion of mowing.

IV. Maintenance and Storage

- Keep all nuts, bolts and screws tight to be sure the equipment is in safe working condition.
- Never store the equipment with petrol in the tank inside a building where fumes may reach an open flame or spark.
- Allow the engine to cool before storing in any enclosure.
- To reduce the fire hazard, keep the engine, silencer, battery compartment and petrol storage area free of grass, leaves, or excessive grease.
- Check the grass catcher frequently for wear or deterioration.
- Replace worn or damaged parts for safety.
- If the fuel tank has to be drained, this should be done outdoors.
- On multi-bladed machines, take care as rotating one blade can cause other blades to rotate.
- When machine is to be parked, stored or left unattended, lower the cutting means unless a positive mechanical lock is used.

 **CAUTION: Always disconnect spark plug wire and place wire where it cannot contact spark plug in order to prevent accidental starting when setting up, transporting, adjusting or making repairs.**

 These symbols may appear on your tractor or in the literature supplied with the product. Learn and understand their meaning.

R
REVERSE

N
NEUTRAL

H
HIGH

L
LOW

FAST

SLOW

LIGHTS ON

LIGHTS OFF



ENGINE ON

ENGINE OFF

PARKING BRAKE LOCKED

UNLOCKED

PARKING BRAKE

BATTERY

CLUTCH

CHOKE

FUEL

OIL PRESSURE

DIFFERENTIAL LOCK

REVERSE

FORWARD

IGNITION

ATTACHMENT
CLUTCH ENGAGED

ATTACHMENT
CLUTCH DISENGAGED

CAUTION

MOWER HEIGHT

BEWARE OF
THROWN OBJECTS

Eng These symbols may appear on your tractor or in the literature supplied with the product. Learn and understand their meaning.



**NO OPERATION
ON SLOPES MORE THAN 10°**



KEEP BYSTANDERS AWAY



READ OWNERS MANUAL



**EUROPEAN MACHINERY
DIRECTIVE FOR SAFETY**



WARNING

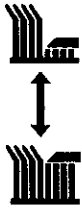

MOWER LIFT



DANGER, KEEP HANDS AND FEET AWAY

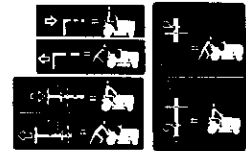

FREE WHEEL



DO NOT OPERATE WITHOUT BAGGER OR DEFLECTOR

⚠ DANGER/POISON

3-3908



SHIELD EYES.

EXPLOSIVE GASES
CAN CAUSE BLINDNESS OR INJURY.



NO

- SPARKS
- FLAMES
- SMOKING



SULFURIC ACID

CAN CAUSE
BLINDNESS OR
SEVERE BURNS.

FLUSH EYES IMMEDIATELY WITH WATER. GET MEDICAL HELP FAST.



RECYCLE

**Mfg. by/
EPM Products
Baltimore, MD 21226**

MADE IN U.S.A.

**KEEP OUT OF THE REACH OF CHILDREN.
DO NOT TIP. DO NOT OPEN BATTERY!**

2. Assembly.

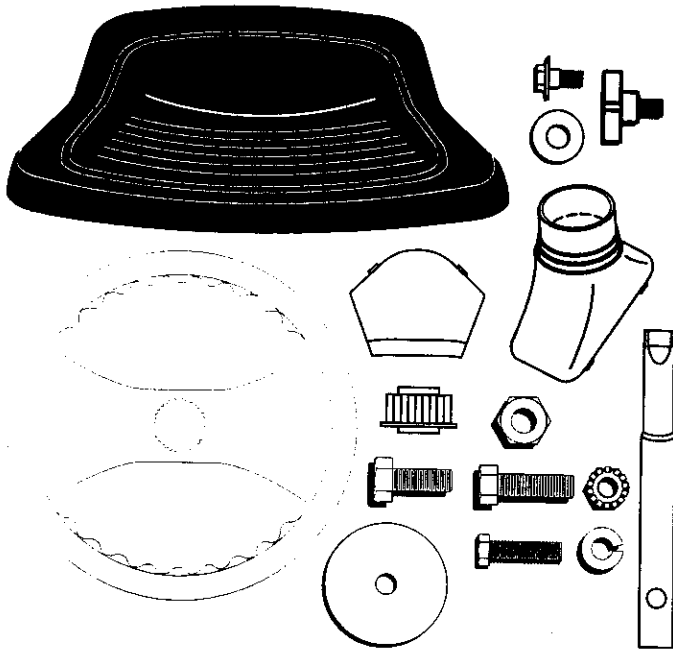

Eng Before the tractor can be used certain parts must be assembled, which for transportation reasons are enclosed in the packing. The picture shows which parts must be assembled.

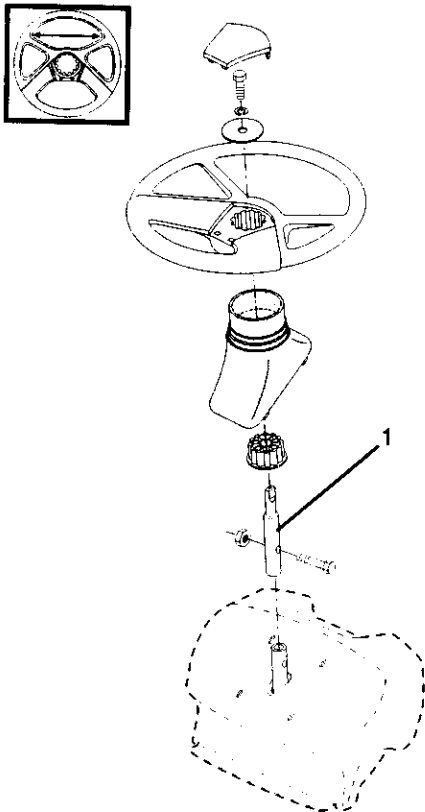

Eng STEERING WHEEL

- Mount extension shaft (1). Tighten securely.
- Mount the main shaft cover. Make sure that the guide tabs in the cover fit the cover in respective holes.
- Remove steering wheel adapter from steering wheel and slide adapter onto steering shaft. Check that the front wheels are aligned forward and place the wheel on the hub.
- Assemble large flat washers, lockwasher and 3/8 hex bolt. Tighten securely.
- Snap insert into center of steering wheel.

1. EXTENSION SHAFT

2

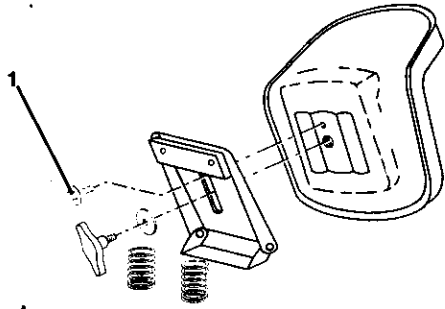

Eng Seat

Remove the hardware securing seat to the cardboard packing and set the hardware aside for assembly of seat to tractor.

Pivot seat upward and remove from cardboard packing. Remove the cardboard packing and discard.

The seat is adjustable for individual setting in relation to the clutch and brake pedal. Fold up the holder for the seat and fit the barrel screw (1).

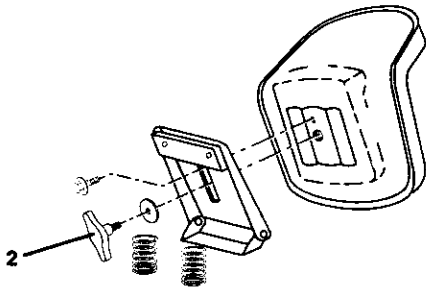

Eng Set the seat to the correct position by moving it forwards or backwards. Tighten the adjustment bolt securely (2).

D Den Sitz vor- oder zurückschieben, bis die richtige Sitzstellung erhalten wird. Die Einstellschraube anziehen (2).

(Eng)

NOTE!

Check that the flex is correctly connected to the safety switch (3) on the seat holder.

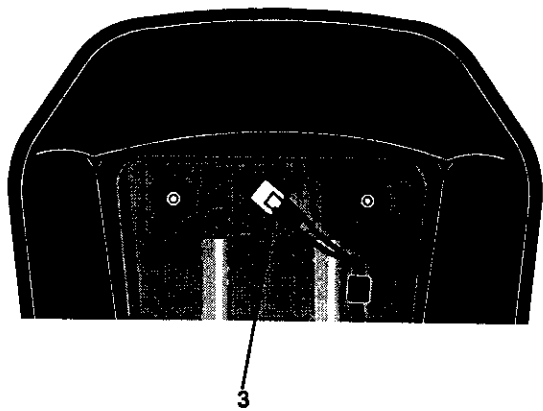

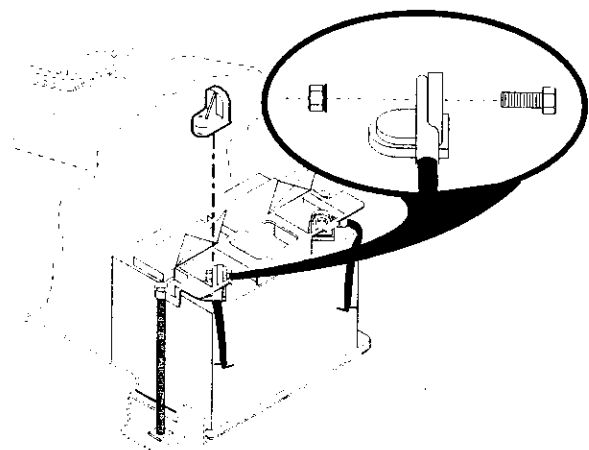

Eng **NOTE:** If battery is put into service after month and year indicated on label, charge battery for minimum of one hour at 6-10 amps.

WARNING: Before installing battery remove metal bracelets, wrist watch bands, rings, etc. from your person. Touching these items to battery could result in burns.

Open doors over battery poles, remove terminal protective caps and discard. Connect the red cable to (+) and then the black earth cable to (-). Screw tight the cables. Grease the battery poles with vaseline to prevent corrosion.

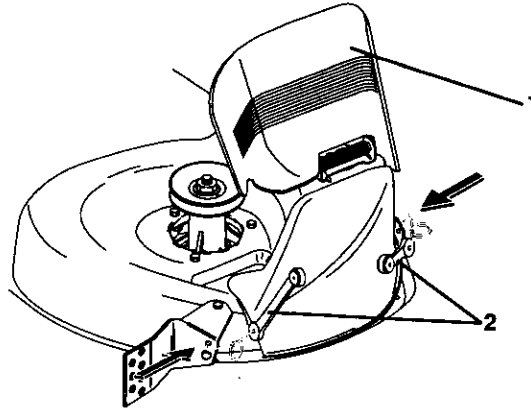

Eng **Install Mulcher Plate**

- Raise deflector shield (1) and place mulcher plate over opening.
- Hook front and rear latches into mower deck (2).

CAUTION: Do not remove deflector shield from mower. Allow deflector shield to rest on mulcher plate while in use.

Convert to bagging or discharging

Remove mulcher plate and store in a safe place. Mower is now ready for discharging or installation of optional grass catcher.

Note: It is not necessary to change blades. The mulcher blades are designed for discharging and bagging also.

3. Functional description.

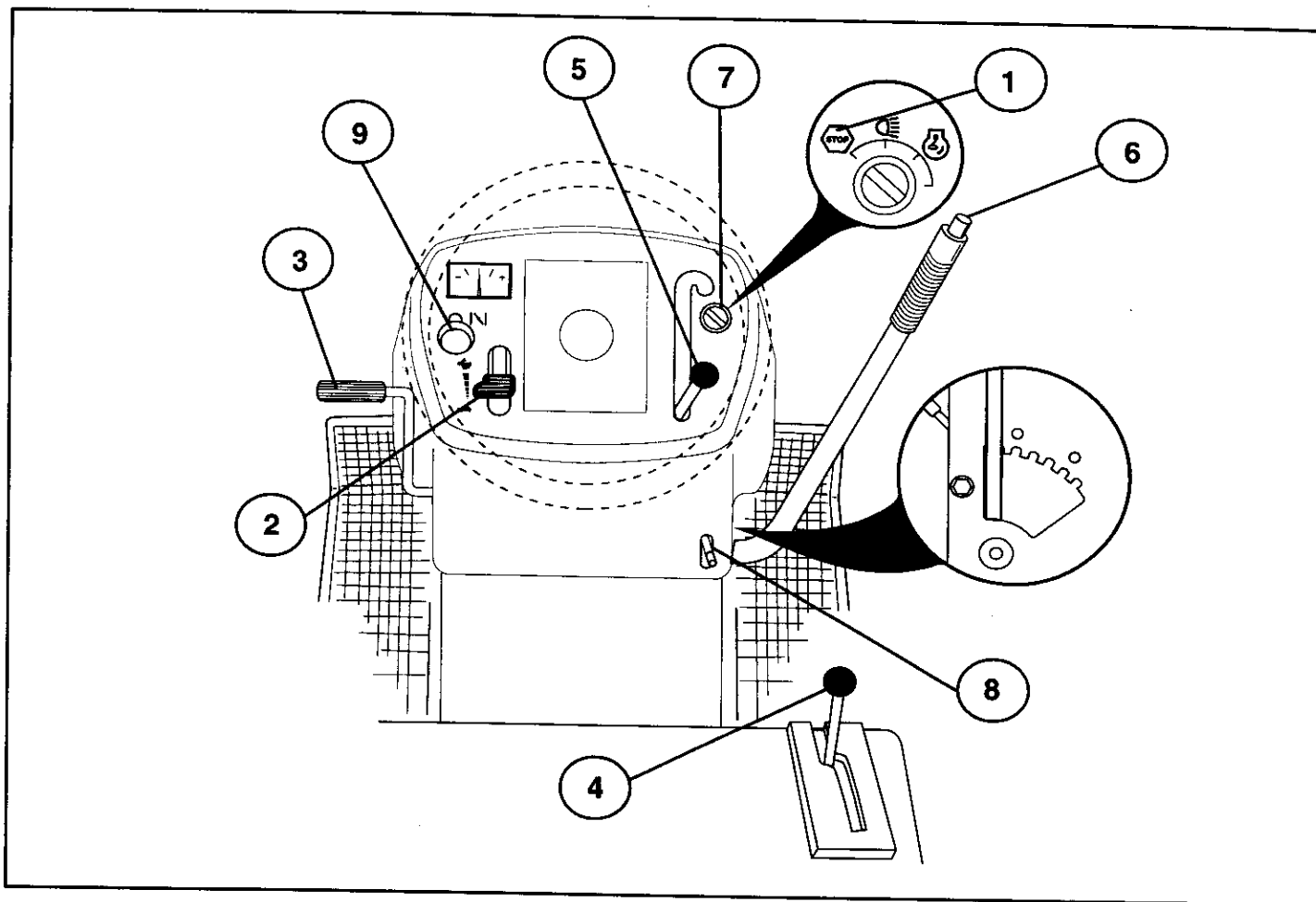

(Eng) Positioning of controls

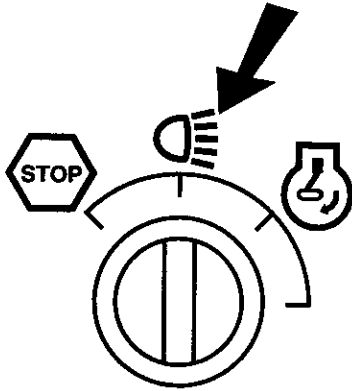

1. Light Switch.
2. Throttle Control.
3. Brake and clutch pedal.
4. Gear Shift Lever.
5. Connection/disconnection of the cutting unit.
6. Quick lifting/lower of the cutting unit.
7. Ignition lock.
8. Parking Brake.
9. Choke Control

(Eng) 1. Light switch



(Eng) 2. Throttle control

The throttle control regulates the engine revs and thus the rotation speed of the blades.

-  = Full speed
-  = Idling speed

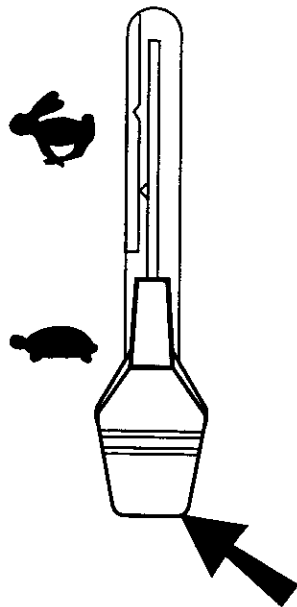

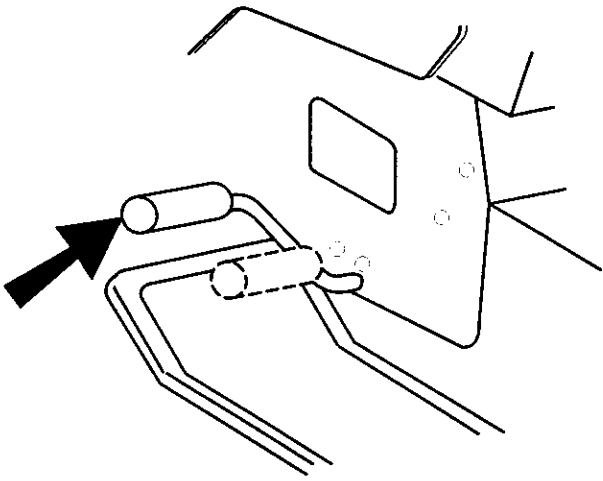

Eng

3. Brake and clutch pedal

When the pedal is pushed down the brake is applied and the motor is disengaged.

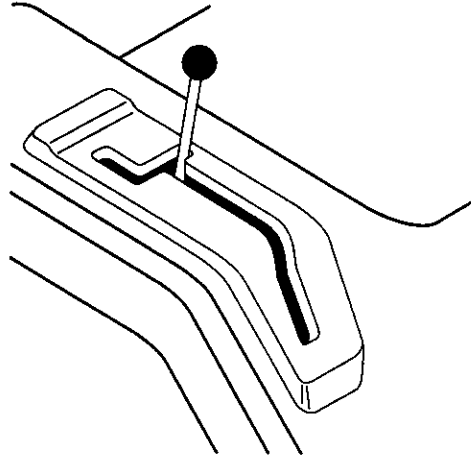

(Eng) 4. Gear shift lever

The gear box has positions forward, neutral and reverse. Gear changing can take place from neutral to top gear without stopping in each gear position. Disengage the motor at each gear position! Start can take place irrespective of the gear lever position.

NOTE!

Stop the machine before changing from reverse to forward gear, or the opposite. Gear changing between the forward gears must not take place when the machine is in motion.

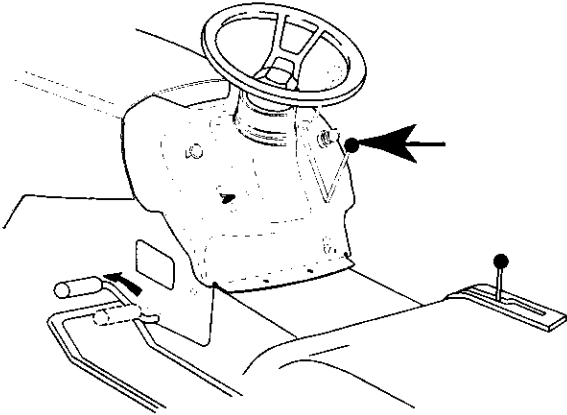

(Eng) 5. Connection/disconnection of the cutting unit

Move the lever forwards to connect the drive to the cutting unit, whereby the drive belt is tensioned and the blades begin to rotate. If the lever is moved backwards the drive will be disconnected and the rotation of the blades slowed down by the action of the brake shoes on the pulley.

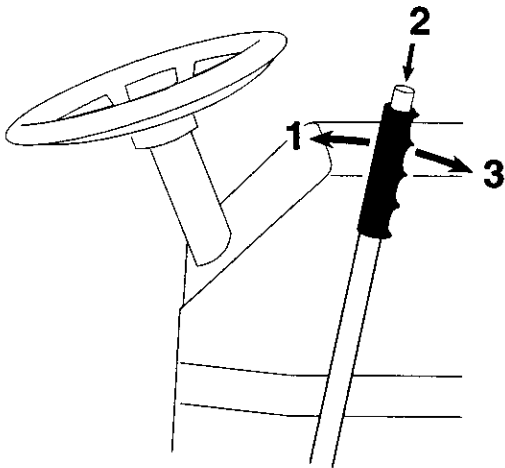

(Eng) 6. Quick lifting/lowering of the cutting unit

Pull the lever backwards to quickly lift the cutting unit when passing over irregularities in the lawn, etc. During transportation the cutting unit shall be in the highest position. Pull the lever back until it locks. To lower the unit: Pull the lever backwards (1). Push in the button (2) and then move the lever forwards (3).

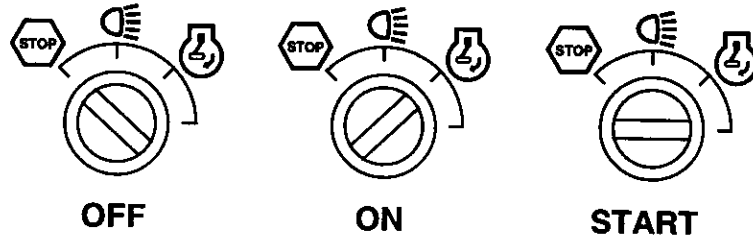

Eng 7. Ignition Lock

There are three different positions for the ignition key:

- OFF All electric current broken.
- ON Electric current connected.
- START Start motor connected.

WARNING!

Never leave the key in the ignition lock when leaving the machine on its own.

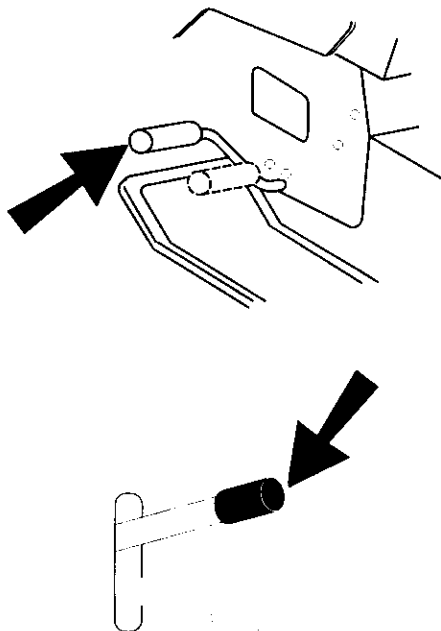

Eng 8. Parking brake

Connect the parking brake in the following way:

1. Press down the brake pedal to bottom position.
2. Move the parking brake lever upwards and hold in this position.
3. Release the brake pedal.

To release the parking brake all that is necessary is to push down the brake pedal.

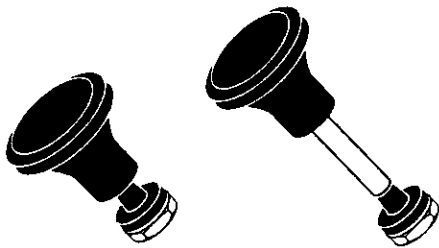
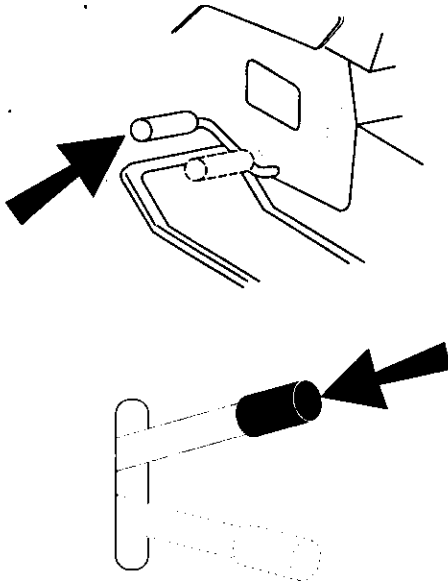

(Eng) 9. Choke control

When the engine is cold the choke should be pulled out before starting. When the engine has started and is running smoothly push the choke in.

4. Before starting.

Filling up

The engine should be run on pure (not oil mixed) unleaded petrol. Do not fill beyond the lower edge of the filling hole. Do not fill over max level.

WARNING!

Petrol is highly inflammable. Proceed with care and fill up with petrol outdoors. Do not smoke when filling with petrol or fill up when the engine is warm. Do not overfill the tank since the petrol can expand and overflow. Make sure that the petrol cap is securely tightened after filling. Store petrol in a cool place in an appropriate container for engine fuel. Check the petrol tank and pipes.

Eng Oil level

The combined oil refilling cap and the oil stick is accessible when the bonnet is lifted forwards. The oil level in the engine should be checked before each run. Make sure that the tractor is horizontal. Unscrew the oil stick and wipe clean. Replace the oil stick and screw tight. Remove again and check the level.

Eng The oil level should lie between the two markings on the oil stick. If more oil is needed add SAE 30 oil to the "FULL" marking. SAE 5W-30 oil should be used during the winter (below freezing point).

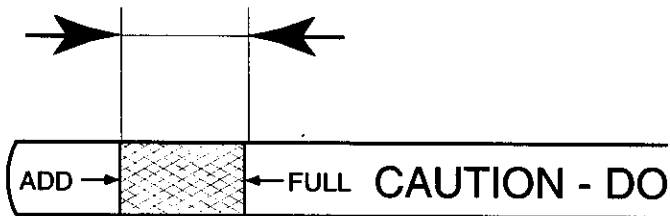



Tire air pressure

Check the tyre pressure regularly. The pressure in the front tyres should be 1 bar (14 PSI) and 0.8 bar (12 PSI) in the back tyres.

5. Driving.

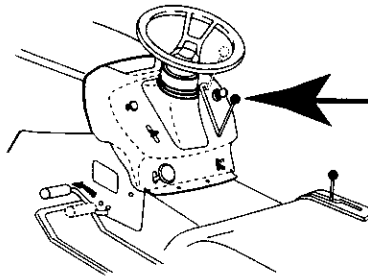

Eng Starting of motor

Make sure that the cutting unit is in the transport position (top position) and that the lever for connection/disconnection of the cutting unit is in the disconnection position.

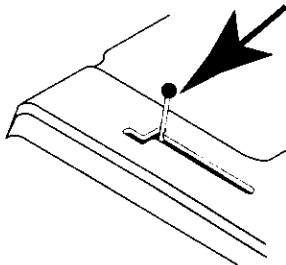

Eng Press down the clutch/brake pedal completely and hold down. Set the gear lever in neutral "N".

Eng Pull out the choke control (if engine is cold).

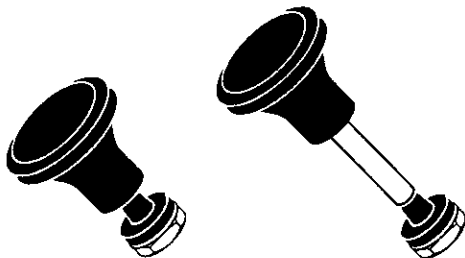

5



(Eng) Warm motor: Push the gas control half-way to full gass position "←".

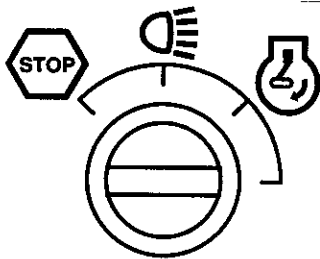

(Eng) Turn the ignition key to "START position".

NOTE!

Do not run the start motor more than 5 seconds at once. If the engine will not start, wait about 10 seconds before the next try.

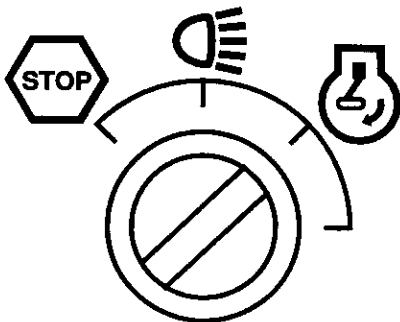

Let the ignition key return to the "ON" position when the engine has started and push in the choke control as soon as the engine is running smoothly. Push the gas control to the required speed. For cutting: full gas.

(Eng)

Eng

NOTE!

The machine is equipped with a safety switch which immediately breaks the current to the engine if the driver leaves the seat with engine running and with the connection/disconnection lever in position "connection". Your machine is also equipped with a system that will not allow mower to operate if the bagger or optional rear discharge deflector is not installed properly.

Eng

Driving

Lower the cutting unit by moving the lever forwards. Connect the cutting unit. Choose a driving speed which suits the terrain and required cutting results. Release the brake/clutch pedal slowly.

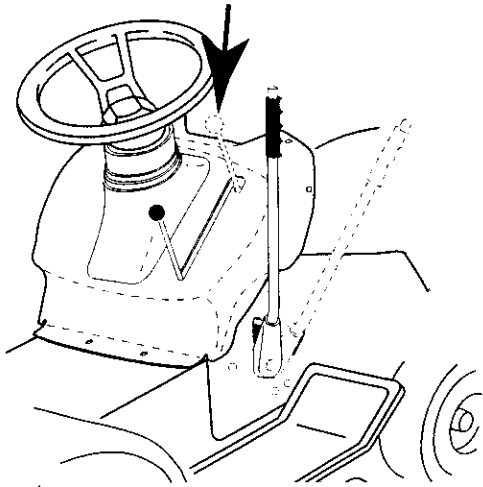



Cutting tips

- Clear the lawn from stones and other objects which can be thrown away by the blades.
- Localize and mark stones and other fixed objects to avoid collision.
- Begin with a high cutting height and reduce until the required cutting result is obtained.
- The cutting result is best with high engine speed (blades rotate quickly) and low gear (machine goes slowly). If the grass is too long and thick the drive speed can be increased by selecting a higher gear or reducing the motor speed, without affecting the cutting result.
- The best lawn is achieved if the grass is cut often. Cutting becomes more even and the cut grass is more evenly distributed over the surface. Total time taken is not greater, since higher drive speed can be selected without affecting the cutting results.
- Avoid cutting wet grass. The cutting results will be worse since the wheels will sink into the soft lawn.
- Spray the cutting unit with water underneath after use.

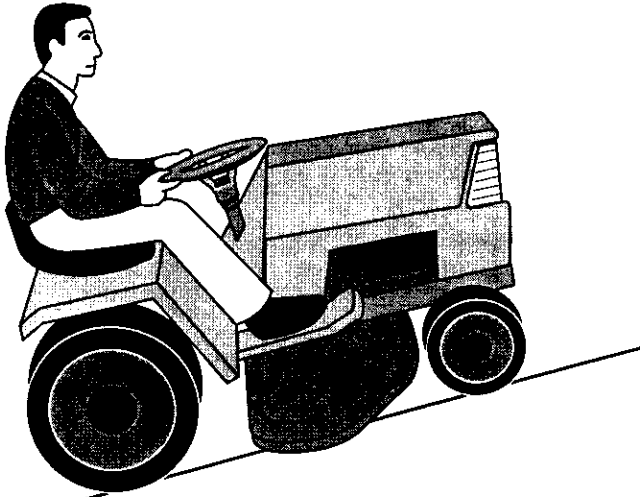

(Eng) WARNING!

- Do not drive in terrain at an angle of more than max. 10°. The risk for spark-over backwards is large.
- In steep terrain the risk for tipping is considerable.
- Avoid stopping and starting in sloping terrain.
- Only change gear when the machine is standing still to avoid damaging the gear box.

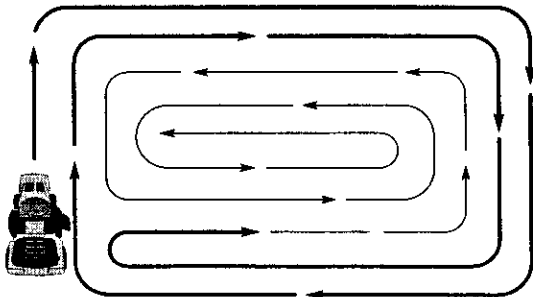

- (Eng)** Drive in right turns so that the cut grass is thrown away from flower beds and paths, etc. For larger lawns the drive direction should be changed after 2-3 turns so that the cut grass is thrown towards the area that has already been cut as shown in the illustration.

(Eng) Use the left side of the machine to cut close to trees, bushes and paths, etc. The blade cuts about 15 mm inside the edge of the cover.

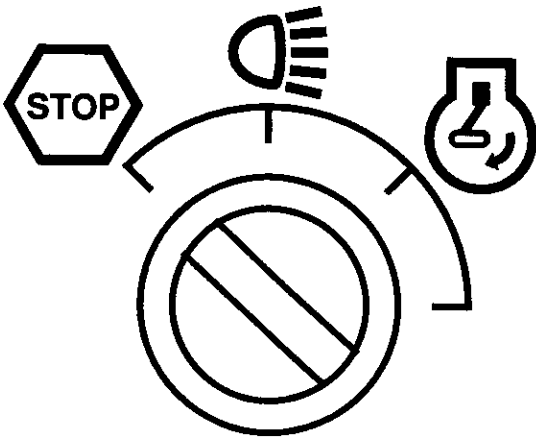

(Eng) **Switching off the engine**

Move the gas control to “”.

Disconnect the cutting unit by moving the connect/disconnect lever downwards.

Lift up the cutting unit and turn the ignition key to “OFF” position.

Allow the engine to idle for 1-2 minutes to cool down before switching off after a hard work.

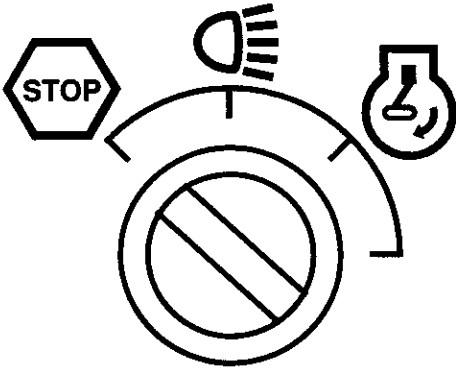

(Eng)

WARNING!

Do not leave the ignition key in the machine when not in use to prevent children and other unauthorized persons starting the engine.

6. Maintenance, adjustment.

Eng

WARNING!

Before servicing the engine or cutting unit the following shall be carried out:

- Press down the clutch/brake pedal and engage the parking brake lever.
- Put gear lever in neutral.
- Move connection/disconnection lever to disengaged position.
- Switch off engine.
- Remove the ignition cable from the plug.

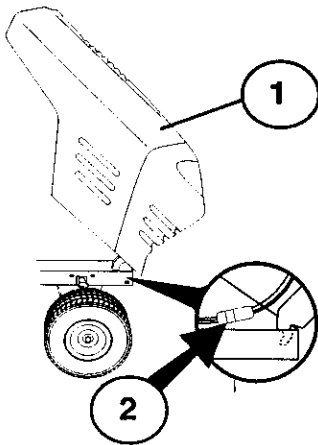

Eng

- (1) Hood
- (2) Headlight wire connector

Eng

Engine hood

- Raise hood.
- Unsnap headlight wire connector.
- Stand in front of tractor. Grasp hood at sides, tilt forward and lift off of tractor.
- To reinstall, slide hood pivot brackets into slots in frame.
- Reconnect headlight wire connector and close hood.

Maintenance

NOTE: Periodic maintenance should be performed on a regular basis in order to keep your tractor in good running condition.

WARNING: Disconnect spark plug wire to prevent accidental starting before attempting any repair, inspection, or maintenance.

Before each use:

- Check oil, lubricate pivot points as necessary.
- Check to see all bolts, nuts, and cotter pins are in place and secure.
- Check the battery, terminals and vents.
- Recharge slowly at 6 amperes if needed.
- Clean air screen.
- Keep tractor free of dirt and chaff to prevent engine damage or overheating.
- Check brake operation.

6

(Eng)

SERVICE RECORD

FILL IN DATES AS YOU COMPLETE REGULAR SERVICE

	As Needed	Every 8 hours	Every 25 hours	Every 50 hours	Every 100 hours	Every 200 hours
Change engine oil			•			
Lubricate pivot points			•			
Check brake operation	•					
Clean air screen		•				
Clean air filter and pre-cleaner		•				
Replace air cleaner paper cartridge					•	
Clean engine cooling fins				•		
Replace spark plug					•	
Check tire pressure	•					
Replace fuel filter						•
Clean battery and terminals			•			
Check muffler				•		
Lubricate ball joints					•	
Toe-in adjustment	•					
Carburetor adjustment	•					

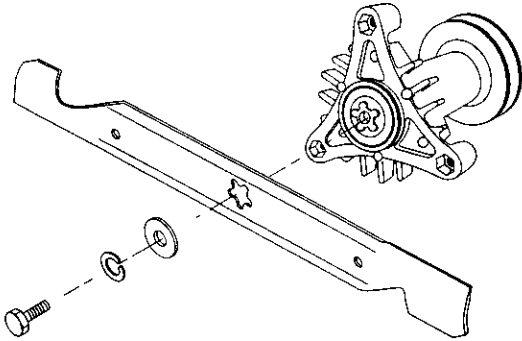

(Eng) Blades

For best results mower blades must be kept sharp. Replace bent or damaged blades. Sharpening can be carried out with a file or grinding disc.

NOTE! It is very important that both blades are sharpened equally to avoid imbalance.

BLADE REMOVAL:

- Raise mower to highest position to allow access to blades.
- Remove hex bolt, lock washer and flat washer securing blade.
- Install new or resharpened blade with trailing edge up towards deck as shown.

IMPORTANT:: To ensure proper assembly, center hole in blade must align with star on mandrel assembly.

- Reassemble hex bolt, lock washer and flat washer in exact order as shown.
- Tighten bolt securely (27-35 Ft. Lbs. torque).

IMPORTANT: Blade bolt is grade 8 heat treated

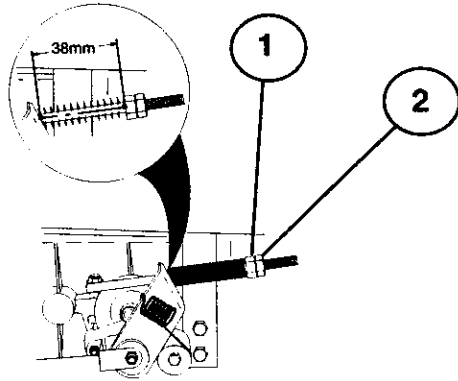

(Eng)

Brakes

The brakes are located inside the right rear wheel. The wheel should be dismantled for best access.

- Press down the clutch/brake pedal and engage the parking brake.

(Eng)

1. Measure the distance between the brake lever and the adjuster nut.
2. The distance should be 38mm (1.5").
3. Adjust the distance if necessary by first loosening the lock nut (2) and then adjusting with the nut (1).

(Eng)

WARNING!

Do not forget to tighten the lock nut after completing adjustment.

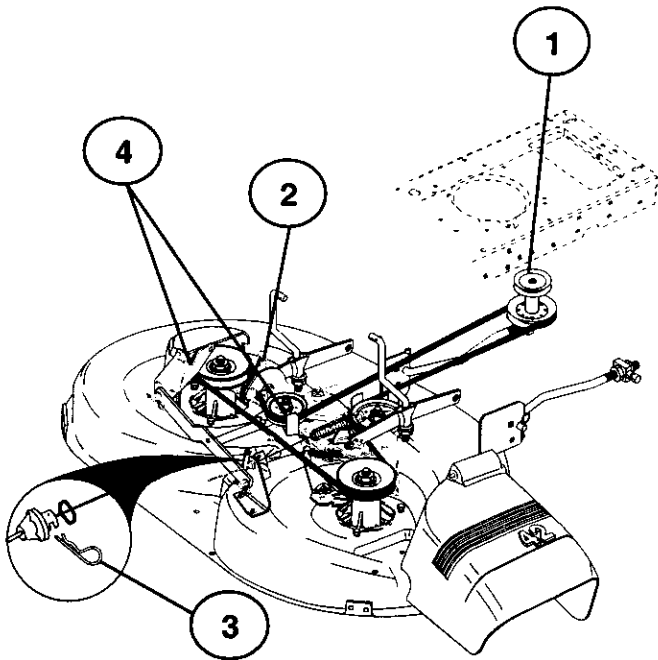

Eng **Dismantling of the cutting unit**

Work from the right side of the machine.

1. Take off the belt from the engine pulley (1).
2. Remove the small retainer spring (2) and lift clutch spring off the pulley bolt.
3. Remove the large retainer spring (3), slide collar off and push housing guide out of the bracket.
4. Remove the two rear retainer springs (4) and knock off the axle taps with a hammer.

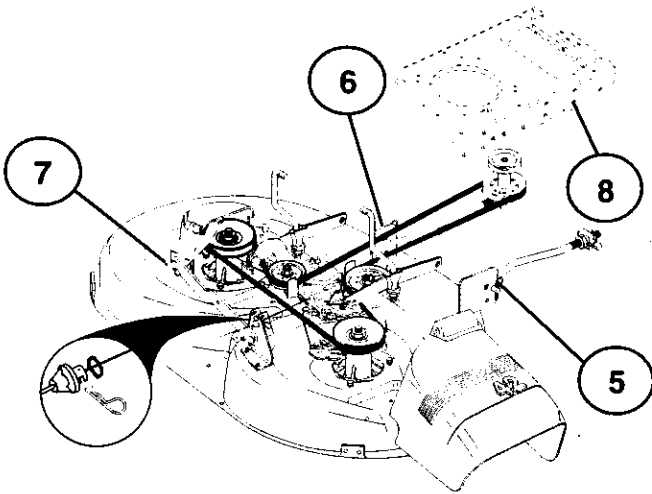

- (Eng) 5: Remove the retainer springs (5), (6), (7) and axles.
6. Pull the lever for lifting/lowering the cutting unit backwards.
7. Pull out the cutting unit from the machine.

IMPORTANT: If an attachment other than the mower deck is to be mounted on the tractor, remove the front links and hook the clutch spring into square hole in frame (8).

(Eng) **Assembly of the cutting unit**

- Push in the cutting unit under the machine. The ejector opening should be to the right.
- Assemble in the reverse order to dismantling.

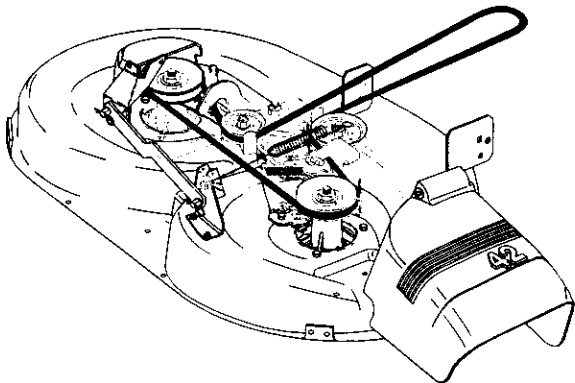

Eng **Replacement of drive belt for cutting unit**

1. Dismantle the cutting unit as described previously.
2. Work off the belt from the unit's left pulley and then from the other wheels.
3. Pull the belt away from the cutting unit.
4. The new belt is mounted in the reverse order. Check that the belt lies inside all the belt guides.

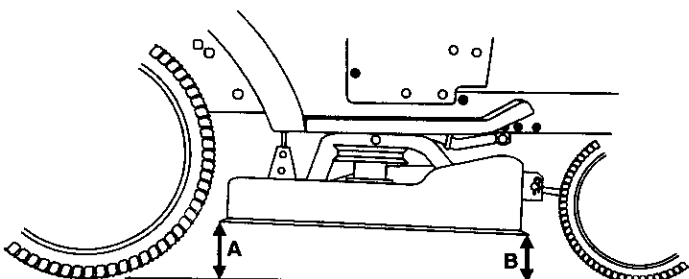

Eng **Adjustment of the cutting unit**

A. In the direction of travel

1. Check that the air pressure is correct in all four tyres.
2. Make sure that the machine is on a horizontal surface.
3. Lift up the cutting unit to its highest position.
4. Measure the distances A and B.

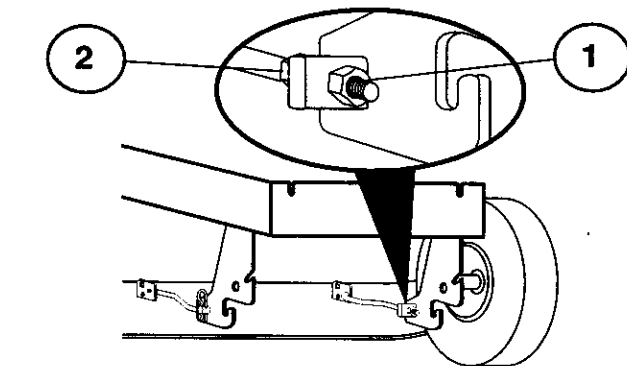
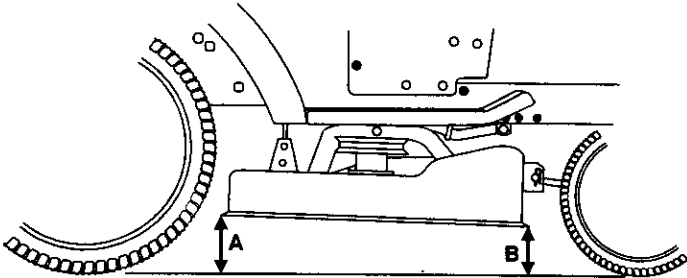

(Eng) To achieve best cutting results the cutting unit's front edge (B) should be about 10 mm (0.375") lower than the back edge (A). Adjust in the following way to raise the back edge:

1. Loosen the nut (1) on both the left and right levers.
2. Screw the nut (2) the same number of turns on both levers.
3. When the correct distance (A) is obtained this setting is locked with the nut (1).

6

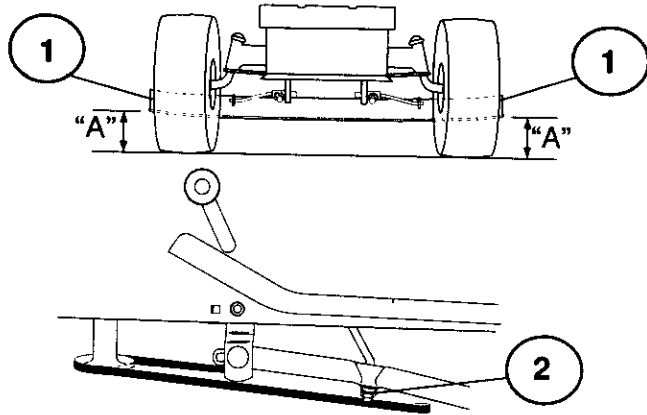

- (Eng) (1) Bottom edge of mower
(2) Lift link adjustment nut

(Eng) SIDE-TO-SIDE ADJUSTMENT

- Raise mower to highest position.
- At the midpoint of both sides of mower, measure height from bottom edge of mower to ground. Distance "A" should be the same or within 6mm (1/4") of each other.
- If adjustment is necessary, make adjustment on one side of mower only.
- To raise one side of mower, tighten lift link adjustment nut on that side.
- To lower one side of mower, loosen lift link adjustment nut on that side.

NOTE: Three full turns of adjustment nut will change mower height about 1/8".

- Recheck measurements after adjusting.

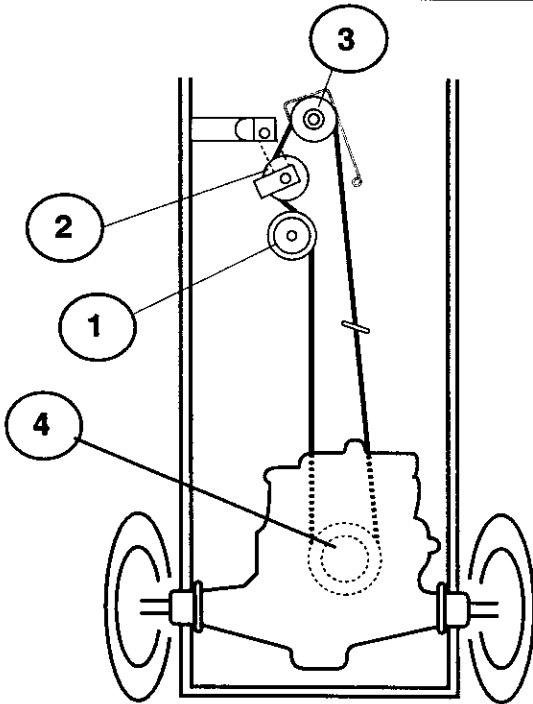

(Eng) Replacement of drive belt

Dismantle the cutting unit as described previously

Engage the parking brake and work off the belt upwards from the pulley (1), the clutch pulley (2) and the engine's drive wheel (3). Work off the belt upwards from the pulley at the rear axle (4).

(Eng) Assemble in the reverse order to dismantling. Check that the belt lies inside all the belt guides. Use original belts only when replacing!

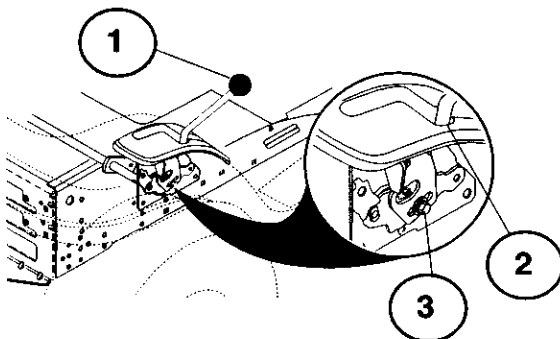

- (Eng)**
1. Gear Shift Lever
 2. Neutral Lock Gate
 3. Adjustment Bolt

(Eng) TRANSAXLE GEAR SHIFT LEVER NEUTRAL ADJUSTMENT

The transaxle should be in neutral when the gear shift lever is in neutral (N) (lock gate) position. The adjustment is preset at the factory; however, if adjustment is needed, proceed as follows:

- Make sure transaxle is in neutral (N).

NOTE: When the tractor rear wheels move freely, the transaxle is in neutral.

- Loosen adjustment bolt in front of the right rear wheel.
- Position the gear shift lever in the neutral (N) position.
- Tighten adjustment bolt securely.

NOTE: If additional clearance is needed to get to adjustment bolt, mow mower deck height to the lowest position.

7. Troubleshooting.

(Eng)

Engine will not start

1. No fuel in fuel tank.
2. Plug defective.
3. Plug connection defective.
4. Dirt in carburettor or fuel pipe.

Start motor will not turn engine

1. Battery flat.
2. Poor contact between cable and battery pole.
3. Connection/disconnection level in wrong position.
4. Main fuse defective.
5. Ignition lock defective.
6. Safety contact for clutch/brake pedal defective.
7. Clutch/brake pedal not pushed down.

Engine runs unevenly

1. Gear too high.
2. Plug defective.
3. Carburettor incorrectly set.
4. Air filter blocked.
5. Fuel tank ventilation blocked.
6. Ignition setting defective.
7. Dirt in fuel pipe.

Engine feels weak

1. Air filter blocked.
2. Plug defective.
3. Dirt in carburettor or fuel pipe.
4. Carburettor incorrectly set.

Engine overheats

1. Engine overloaded.
2. Air inlet or cooling fins blocked.
3. Fan damaged.
4. Too little or no oil in engine.
5. Ignition setting defective.
6. Plug defective.

Battery does not charge

1. Fuse defective.
2. One or several cells defective.
3. Poor contact between battery poles and cables.

Lighting does not function

1. Bulbs defective.
2. Switch defective.
3. Short-circuit in cable.

The machine vibrates

1. Blades loose.
2. Engine loose.
3. Unbalance in one or both blades resulting from damage or poor balancing after sharpening.

Uneven cutting results

1. Blades blunt.
2. Cutting unit skew.
3. Long or wet grass.
4. Grass stuck under cover.
5. Different air pressures in tyres on left and right side.
6. Gear too high.
7. Drive belt slipping.

8. Storage.

(Eng) The following steps should be taken when mowing season is over:

- Clean the entire machine, especially underneath the cutting unit cover.
- Touch up all chipped paint surfaces in order to avoid corrosion.
- Change engine oil.
- Drain the fuel tank. Start the engine and allow it to run until it is out of fuel.
- Remove the spark plug and pour one table spoon of engine oil into the cylinder. Pull the engine over in order to distribute the oil. Return the spark plug.
- Remove the battery. Recharge and store it in a cool, dry place. Protect the battery from low temperatures.
- The machine should be stored indoors in a dry, dust-free place.

WARNING!

Never use gasoline when cleaning. Use degreasing detergent and warm water instead.

Service

When ordering, we need the following information:

Date of purchase, model, type and serial number of the mower. Always use original spare parts. Contact your local dealer of distributor for warranty service and repairs.

(

