



User's Guide

Series 1720 Portable Deep Cleaners

- Assembly
- Operation
- Safety
- Storage

Thanks for buying a BISSELL Portable Deep Cleaner.

We're glad you purchased a BISSELL Little Green™ Portable Deep Cleaner. Everything we know about floor care went into the design and construction of this handy, high-tech home cleaning system.

Your Little Green is well made, and we back it with a full one-year warranty. We also stand behind it with a knowledgeable, dedicated Consumer Services department, so, should you ever have a problem, you'll receive fast, considerate assistance.

My great-grandfather invented the floor sweeper in 1876. Today, BISSELL is a global leader in the design, manufacture, and service of high quality homecare products like your Little Green.

Thanks again, from all of us at BISSELL.

Mark J. Bissell

Mark J. Bissell
President and Chief Executive Officer

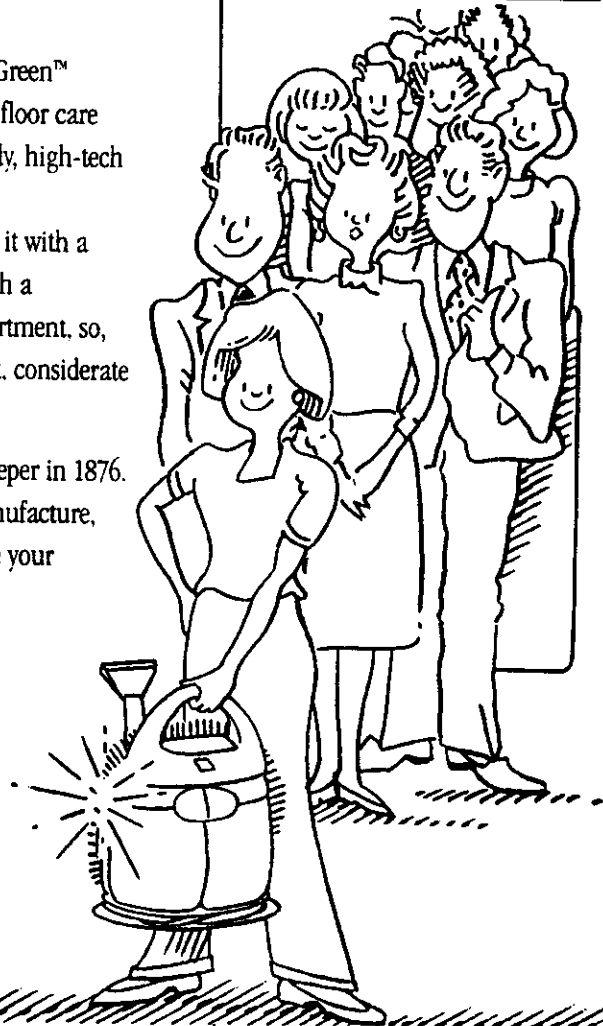

- Easy to fill and empty
- Store ready-to use with cleaning formula
- Specialized tools for all cleaning needs

IMPORTANT SAFETY INSTRUCTIONS

When using an electrical appliance, basic precautions should be observed, including the following:

Read all instructions before using your Little Green

⚠ WARNING: To reduce the risk of fire, electric shock or injury:

- Do not expose to rain
- Do not immerse
- Store indoors
- Use only on surfaces moistened by cleaning process
- Always connect to a properly grounded outlet
- Unplug from outlet when not in use and before conducting maintenance or troubleshooting
- Do not leave machine when it is plugged in
- Do not service machine when it is plugged in
- Do not use with damaged cord or plug
- Do not use machine if it has been dropped, damaged, left outdoors or dropped into water
- Do not handle unit with wet hands
- Do not pull or carry by cord, use cord as a handle, close door on cord, pull cord around sharp corners or edges, run appliance over cord, or expose cord to heated surfaces
- Do not unplug by pulling on cord
- Do not put any object into appliance openings, use with blocked opening, or restrict air flow
- Do not expose hair, loose clothing, fingers or body parts to openings or moving parts
- Do not pick up hot or burning objects
- Do not pick up flammable or combustible materials (lighter fluid, gasoline, kerosene, etc.) or use in the presence of explosive liquids or vapor
- Do not use appliance in an enclosed space filled with vapors given off by oil base paint, paint thinner, some moth proofing substances, flammable dust, or other explosive or toxic vapors
- Do not pick up toxic material (chlorine bleach, ammonia, drain cleaner, gasoline, etc.)
- Do not modify the 3-prong grounded plug
- Do not allow to be used as a toy

- Do not use for any purpose other than described in this User's Guide
- Use only manufacturer's recommended attachments
- Use only cleaning products formulated or recommended by BISSELL for use in this appliance
- Keep openings free of dust, lint, hair, etc.
- Keep appliance on a level surface
- Turn off all controls before unplugging
- Unplug by grasping the plug, not the cord
- Be extra careful when cleaning stairs
- Pay close attention when working around children

SAVE THESE INSTRUCTIONS GROUNDING INSTRUCTIONS

This appliance must be grounded. If it should malfunction or breakdown, grounding provides a path of least resistance for electric current to reduce the risk of electric shock. This appliance is equipped with a cord having an equipment-grounding conductor and grounding plug. The plug must be inserted into an appropriate outlet that is properly installed and grounded in accordance with all local codes and ordinances.

⚠ WARNING: Improper connection of the equipment-grounding conductor can result in a risk of electrical shock. Check with a qualified electrician or service person if you aren't sure if the outlet is properly grounded. **DO NOT MODIFY THE PLUG.** If it will not fit the outlet, have a proper outlet installed by a qualified electrician. This appliance is designed for use on a nominal 120-volt circuit, and has a grounding attachment plug that looks like the plug in the drawing above. Make certain that the appliance is connected to an outlet having the same configuration as the plug. No plug adapter should be used with this appliance.

This model is for household use only.



⚠ WARNING: Do not use this product with any type of a ladder. Do not place the product in a place where it will be stepped on or kicked while in use. Do not place the product on an elevated surface where it may be pulled off the surface while in use.

⚠ WARNING: Do not use an extension cord with this product. The use of an extension cord may result in a severe electrical shock, particularly if the extension cord does not have an electrical rating higher than that of the product, if the extension cord does not have a three prong grounding plug and connector and if the extension cord is not plugged into a circuit box with a ground fault circuit interrupter. Safety precautions such as keeping all connections off the ground and dry will not eliminate the danger.

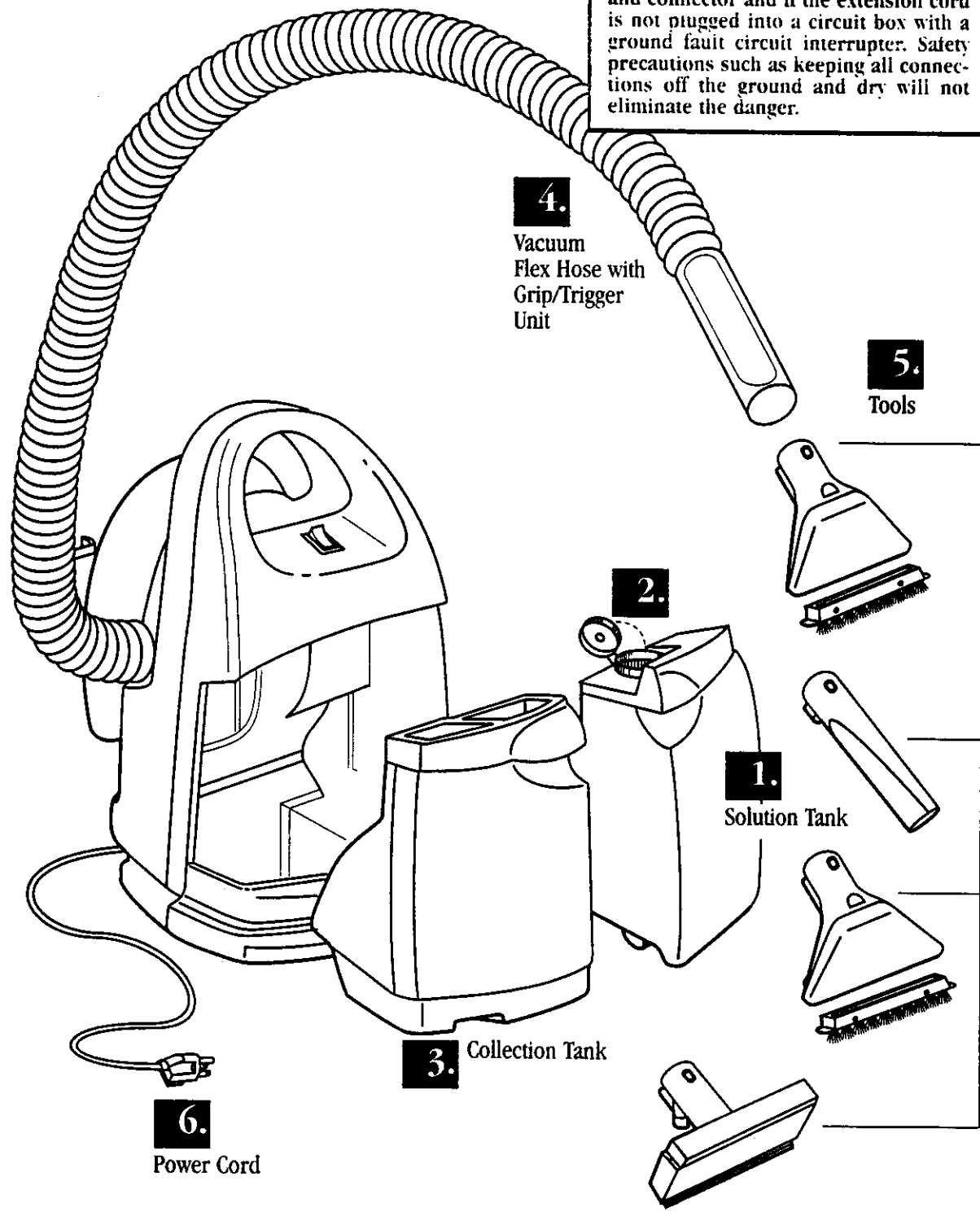

1.
2.
3.
4.

How to use this guide

This User's Guide has been designed to help you get the utmost satisfaction from your Little Green Portable Deep Cleaner. You'll find assembly instructions for all cleaning tasks, safety precautions, pre-cleaning tips, and maintenance and troubleshooting instructions. Please read this Guide thoroughly before using your Little Green.

Pay particular attention to the parts diagram, assembly instructions, and part names. Familiarize yourself with the tools and how they're used. Following the Guide will greatly enhance your ability to get the most performance from your Little Green for many years.

How to put it together

Your Little Green Portable Deep Cleaner comes assembled and ready to use. The exploded view drawing and part names may come in handy if you should need to order a part.

Solution Tank

1. The Solution Tank is the translucent tank at your right as you face the Little Green. Remove the Tank by grasping the indented handle and pulling it toward you, then tilting out.

2. Open the Solution Tank by pulling up on the round cap. Add BISSELL Little Green formula to the formula fill line (8-oz.) on Solution Tank. NOTE: Your Little Green is shipped with an 8 oz. starter bottle of formula.

Fill the Solution Tank with hot (NOT boiling) tap water to the water fill line.

Replace the cap before placing the Solution Tank back into the unit.

Replace the Solution Tank by placing it bottom first into the cavity, then tilting it, pressing gently at top until it snaps closed.

Collection Tank

3. The Collection Tank is the translucent tank at your left as you face the Little Green. It opens and closes just like the Solution Tank. Empty the Collection Tank after each use, when dirty water reaches the indicated maximum fill line, or as instructed in this User's Guide.

Vacuum Flex Hose with Grip/Trigger Unit

4. Store in the Onboard Hose Storage on the back of the Little Green. Cleaning tools attach to the Grip/Trigger Unit.

NOTE: Unwrap Flex Hose completely before operating unit.

WARNING: Use only BISSELL Little Green formula in your cleaner. Use of cleaning formulas which contain lemon or pine oil may damage this appliance and void warranty. Chemical spot cleaners or solvent-based soil removers should not be used. These products may react with the plastic materials used in your cleaner, causing cracking or pitting.



Tools

- 5.** Depending on which Little Green model you purchased, your deep cleaner is equipped with:

- 4" wide Upholstery/Carpet Tool



- 6" Upholstery/Carpet Tool for larger areas



- Spraying Crevice Tool for hard to reach areas



- Glass-Cleaning Tool for streak-free cleaning

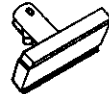

NOTE: You may purchase these tools by calling BISSELL Consumer Services at the telephone number on Page 10.

Power Cord

- 6.** The Cord, with a three-prong grounded plug, stores in the Onboard Cord Storage at the bottom of the Little Green.

NOTE: Unwrap Power Cord completely before operating unit.

Assembly for wet cleaning is now complete.

Index

Safety instructions	2
Product view	3
How to put it together	4-5
Index	5
How to begin	5
How to deep clean carpet or upholstery	6
How to clean glass surfaces	7
Putting it away	7
Troubleshooting	8
Parts	9
Warranty	10
Consumer services	10

How to begin...

Deep cleaning carpet

1. In the case of spills, remove as much surface material as possible before using your Little Green.

Deep cleaning upholstery

1. Check manufacturer's tag before cleaning. "W" or "WS" on the tag means you can use your Little Green. If tag is coded with an "S" (with diagonal strike-through), or says "Dry Clean Only," do not proceed.
2. If manufacturer's tag is missing or not coded, check with your furniture dealer.
3. If possible, check upholstery stuffing. Colored stuffing may bleed through fabric when wet.

Tip:

Check upholstery stuffing before cleaning. Colored stuffing may bleed through fabric when wet.

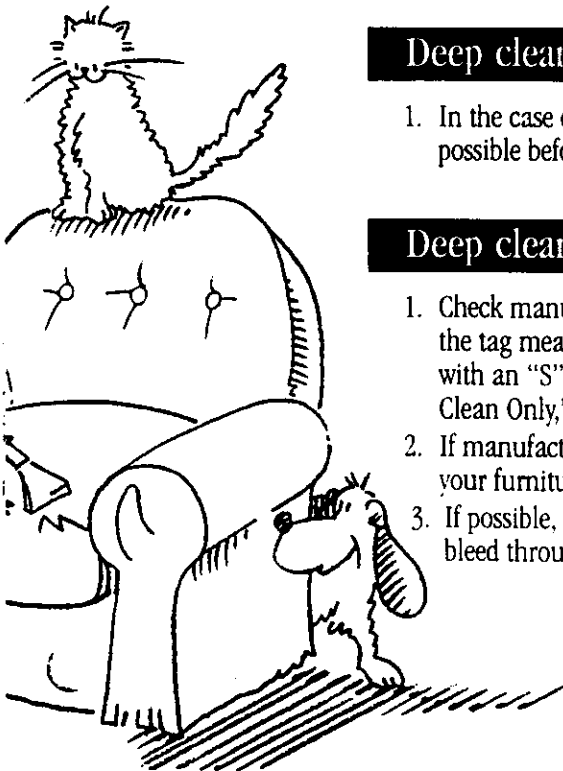

How to deep clean carpet or upholstery

Getting ready

1. Remove Vacuum Flex Hose completely from Onboard Hose Storage.
2. Attach 4" Tool, 6" Tool* or Crevice Tool* to Grip Trigger Unit by pressing Tool onto Grip/Trigger Unit firmly, until button snaps into hole. Make certain Tool is securely attached.
3. Unwrap Power Cord completely from Onboard Cord Storage and plug into 120 Volt, 60 Hz grounded outlet as described in Important Safety Instructions, page 2.
4. If cleaner starts when first plugged in, switch cleaner off until ready for use.
5. Move Power switch to ON position.
6. Press and hold Spray Trigger on Grip/Trigger unit. Spray will start in a few seconds.
7. Raise Upholstery/Carpet Tool slightly to check for spray. If spray does not start, press firmly on the front of the Solution Tank while depressing Spray Trigger.

*Optional on some Little Green models. To order optional parts not originally included in your Little Green model, call

BISSELL Consumer Services
1-800-237-7691

Monday - Friday 8 a.m. — 7 p.m. EST

Saturday 9 a.m. — 1 p.m. EST

Pre-treating

1. Pre-treat stained or highly soiled areas: Hold Upholstery/Carpet Tool or Crevice Tool 4" - 6" above carpet or upholstery, and pull trigger to spray cleaning solution.
2. Wait 3-5 minutes before cleaning.

Deep cleaning

1. Place Upholstery/Carpet Tool directly on soiled surface at arms length. Apply downward pressure on Upholstery/Carpet Tool and pull toward you, while pulling trigger to spray cleaning solution.
2. Repeat, keeping Upholstery/Carpet Tool firmly against surface. Continue until no more dirt can be removed.
Do not overwet.
3. Release spray trigger. **Vacuum area until no more cleaning solution can be removed.** [see WHEN YOU'RE DONE, page 6].
4. If Upholstery/Carpet Tool stops spraying, turn off Power Switch and check cleaning solution level. Refill if needed. Never run pump dry.

Tip:

Deep cleaning stairs and high traffic areas on a regular basis can prolong carpet life.

When you're done

NOTE: Before turning off Little Green, lift Upholstery/Carpet Tool and point upwards. This allows any water still in the Vacuum Flex Hose to flow into the Collection Tank.

1. Turn Power Switch to OFF position.
2. Unplug Power Cord from outlet.
3. Remove and rinse Solution Tank, then replace.
NOTE: If a significant amount of Little Green formula/water remains, you may leave it in the Solution Tank for your next cleaning task.
4. Remove Collection Tank. Be careful not to spill dirty water.
5. Carefully carry Collection Tank to a toilet or sink to empty.
6. Fill Collection Tank with clean water. Rinse thoroughly and discard water.
7. Replace Collection Tank.
8. Disconnect Upholstery/Carpet Tool from Grip/Trigger unit by pushing down on button lock and pulling straight off. (Do NOT twist tools to remove them).
9. Remove brush from Upholstery/Carpet Tool and clean brush under clean running water.
10. Remove clear plastic view window from Upholstery/Carpet Tool by pushing on tab opening while pulling out bottom window lip. Rinse under clean running water.
11. Check Spray Nozzle for accumulated dirt or debris. If necessary, clean with soft bristle brush.
12. See PUTTING IT AWAY on page 7.

How to clean glass surfaces

Getting ready

1. Attach the Glass-Cleaning Tool to the Grip/Trigger unit using the "button-in-hole" method.
2. Remove Solution Tank.
3. Fill Solution Tank with your choice of popular liquid glass-cleaning solution (Windex®, Glass Plus®, etc.).
4. Replace Solution Tank.
5. Unwrap Power Cord completely from Cord Retainer and plug into 120 Volt, 60 Hz grounded outlet as described in Important Safety Instructions, page 2.
6. If cleaner starts when first plugged in, switch cleaner off until ready for use.
7. Move Power Switch to ON position.
8. Press and hold Spray Trigger on Grip/Trigger Unit. Spray will start in a few seconds.
9. Raise Glass-Cleaning Tool slightly to check for spray.

Cleaning

1. The head of the Glass-Cleaning Tool rotates. Begin cleaning with sponge edge of tool rotated in the same direction as the spray tip.
2. Move Power Switch to ON position.
3. Hold Glass-Cleaning Tool approximately 12" from glass mirror, table top, window or other surface to be cleaned, and pull trigger to spray glass-cleaning solution.
4. Use sponge edge to scrub stubborn spots and to spread solution evenly over the glass surface.
5. Rotate head to place squeegee edge at a 45° angle for best results.
6. Repeat this motion over entire surface, until the glass surface is streak-free.
7. Check the Collection Tank. Empty the tank if it is full. [see WHEN YOU'RE DONE, page 6].
8. If Glass-Cleaning Tool stops spraying, turn off Power Switch and check solution level.
9. Refill if needed. Never run pump dry.
10. See WHEN YOU'RE DONE (page 6) and PUTTING IT AWAY (page 7).

NOTE: Before turning off Little Green, lift Glass-Cleaning Tool and point upwards. This allows any water still in the Vacuum Flex Hose to flow into the Collection Tank.

 **WARNING:** Do not use "homemade glass cleaning solutions in your Little Green. These could damage the Little Green and the Glass cleaning Tool. Also, do not use Little Green formula on windows. When cleaning windows after cleaning upholstery or carpet, thoroughly rinse Solution Tank. Then "flush" Little Green by spraying Grip/Trigger Unit over sink or pan until glass cleaner comes out of Spray Nozzle.

 **WARNING:** Keep face away from spray. Failure to do so may result in personal injury.

Putting it away

1. After deep cleaning of carpet or upholstery, or cleaning glass, follow instructions in WHEN YOU'RE DONE, page 6.
2. Wipe all surfaces with a soft cloth.
3. Wrap Power Cord around Onboard Cord Storage at the bottom of Little Green.
4. Wrap Vacuum Flex Hose around Onboard Hose Storage and secure with Hose Clip.
5. Store Cleaner in a protected, dry area, at room temperature (40° to 110°F).

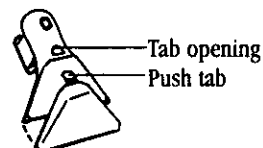

The 4" and 6" cleaning heads are two piece attachments. The attachments clear front window snaps off for easy maintenance and clean-ups.

Troubleshooting



WARNING: To reduce the risk of fire, electric shock or injury, unplug appliance from outlet before servicing.

Cleaner won't run.

<u>Possible Causes</u>	<u>Remedies</u>
Power Unit not plugged in	Check electrical plug
Blown fuse/tripped breaker	Replace household fuse or Reset breaker Call BISSELL Consumer Services

Reduced spray or no spray.

<u>Possible Causes</u>	<u>Remedies</u>
Spray Nozzle clogged	Clean Spray Nozzle
Solution Tank empty	Check/Refill Tank
Solution Tank outlet clogged	Clean outlet at bottom of Solution Tank
Pump needs priming	Push firmly on Solution Tank front while depressing Spray Trigger

Vacuum won't pick up cleaning solution.

<u>Possible Causes</u>	<u>Remedies</u>
Poor Upholstery/Carpet Tool position	Reposition Upholstery/Carpet Tool on surface, follow recommended cleaning procedures.
Poor Glass-Cleaning Tool position	Reposition Tool to 45° angle
Collection Tank is full	Empty Collection Tank
Upholstery/Carpet Tool Brush worn	Replace with new Brush
Excess solution in Vacuum Flex Hose	Lift Tool and point upwards to allow water in Hose to flow into the Collection Tank

Excessive Foam in the Collection Tank.

<u>Possible Causes</u>	<u>Remedies</u>
Residue left in carpet or fabric from prior cleaning	Flush carpet by using clear water in Solution Tank Check Tank often and empty as necessary
Incorrect cleaning formula	Use BISSELL Little Green formula only

Part numbers and descriptions

Item Part No. Part Name

- 1 603-0983 4" Upholstery/Carpet Tool w/Brush
- 2 603-0961 4" Window
- 3 603-0984 4" Removable Brush
- 4 603-0985 6" Upholstery/Carpet Tool w/Brush
- 5 603-0962 6" Window
- 6 603-0986 6" Removable Brush
- 7 603-0987 Spraying Crevice Tool
- 8 603-0988 Glass Cleaning Tool

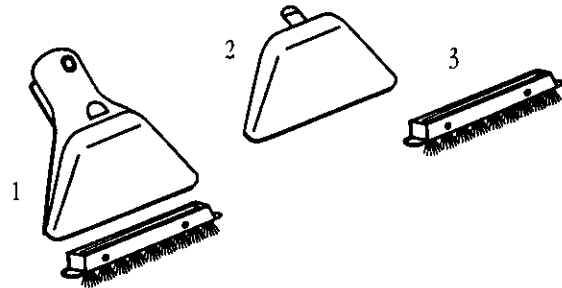

For Model 1720-1/4

- 9 603-1201 Collection Tank-White
- 10 603-1200 Solution Tank-White

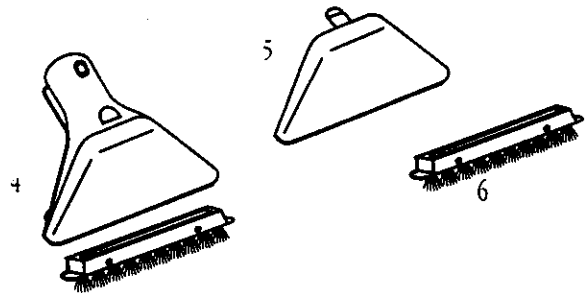

For Model 1720-2

- 11 603-1203 Collection Tank-Tinted
- 12 603-1202 Solution Tank-Tinted

For Model 1720-3/Q

- 13 603-1203 Collection Tank-Tinted
- 14 603-1204 Solution Tank-Tinted

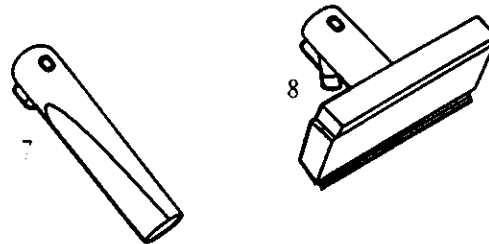

NOTE: To order replacement parts, or to order parts not originally included in your Little Green model, call

BISSELL Consumer Services
1-800-237-7691

Monday - Friday 8 a.m. — 7 p.m. EST

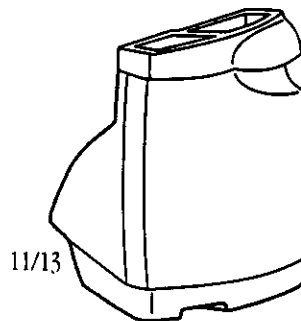
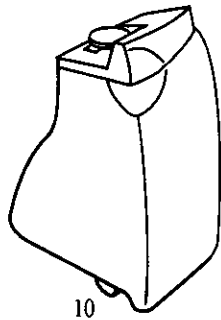
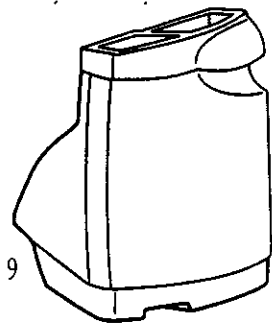

About your warranty

This warranty gives you specific legal rights, and you may also have other rights which may vary from state to state. If you need additional instruction regarding this warranty or have questions regarding what it may cover, call BISSELL Consumer Services.

One Year Warranty

BISSELL Inc., upon receipt of the product, will repair or replace, free of charge, any part which is defective or malfunctioning within one year of the purchase date, provided that it is used for personal and not commercial or rental service. If the deep cleaner cannot be repaired, BISSELL Inc. will replace or refund the full price, at your option.

How to return your BISSELL product for service

1. Call **BISSELL Consumer Services (1-800-237-7691)** for referral to a Bissell Service Center, or for return authorization.
2. Return unit to your dealer with a proof of purchase. (Check return policy of your dealer.)

NOTE: Please keep your original sales receipt. It is your warranty.

BISSELL Consumer Services

For information about repairs or replacement parts, or questions about your warranty, call:

BISSELL Consumer Services

1-800-237-7691

Monday - Friday 8 a.m. — 7 p.m. EST

Saturday 9 a.m. — 1 p.m. EST

Or write:

BISSELL INC

PO Box 3606

Grand Rapids MI 49501

ATTN: Consumer Services

When contacting BISSELL, have model number of unit available.

Please record your Model Number: _____

Please record your Purchase Date: _____



Life's messy. Clean it up.™

© 1997 BISSELL Inc
Grand Rapids, Michigan
All rights reserved. Printed in China
Part Number 603-5840