

USER'S GUIDE

RS-1247
RS-1248

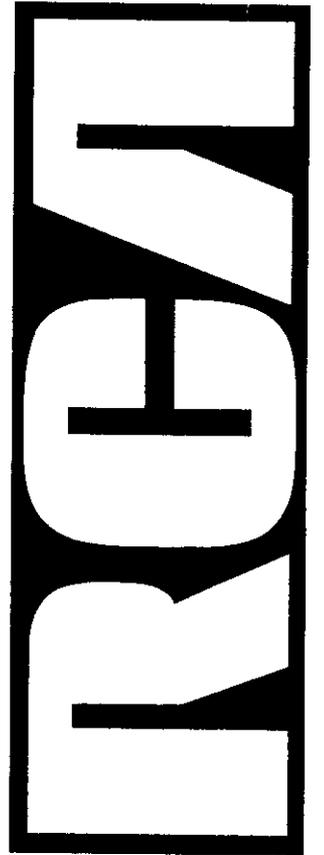

AUDIO SYSTEM

FCC INFORMATION

This device complies with Part 15 of the FCC Rules. Operation is subject to the following two conditions: (1) This device may not cause harmful interference, and (2) this device must accept any interference received, including interference that may cause undesired operation. In accordance with FCC requirements, changes or modifications not expressly approved by Thomson Consumer Electronics could void the user's authority to operate this product.

This product complies with DHHS Rules 21 CFR Subchapter J. Applicable at the date of manufacture.

This device generates and uses radio frequency (RF) energy, and if not installed and used properly, this equipment may cause interference to radio and television reception.

This equipment has been type tested and found to comply with the limits for a Class B Computing Device in accordance with the specifications of FCC Rules. These rules are designed to provide reasonable protection against radio and television interference in a residential installation. However, there is no guarantee that interference will not occur in a particular installation.

If this equipment does cause interference to radio or television reception (which you can determine by turning the equipment off and on), try to correct the interference by one or more of the following measures:

- Reorient the receiving antenna (that is, the antenna for the radio or television that is receiving the interference).
- Change the position of the unit with respect to the radio or television equipment that is receiving interference.
- Move the unit away from the equipment that is receiving interference.
- Plug the unit into a different wall outlet so that the unit and the equipment receiving interference are on different branch circuits.

If these measures do not eliminate the interference, please consult your dealer or an experienced radio/television technician for additional suggestions. Also, the Federal Communications Commission has prepared a helpful booklet, "How To Identify and Resolve Radio TV Interference Problems." This booklet is available from the U.S. Government Printing Office, Washington, DC 20402. Please specify stock number 004-000-00345-4 when ordering copies.

SAFETY PRECAUTIONS

- Never open the cabinet under any circumstances. Any repairs or internal adjustments should be made only by a trained technician.
- **Warning:** Never operate this product with the cabinet removed.
- Do not touch the player with wet hands. If any liquid enters the player cabinet, take the player to a trained technician for inspection.
- This compact disc player uses a laser to read the music on the disc. The laser mechanism corresponds to the cartridge and stylus of a record player. Although this product incorporates a laser pick-up lens, it is completely safe when operated according to directions.

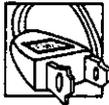

- Discs rotate at high speed inside the player. Do not use damaged, warped, or cracked discs.

FOR YOUR SAFETY

The AC power plug is polarized (one blade is wider than the other) and only fits into AC power outlets one way. If the plug won't go into the outlet completely, turn the plug over and try to insert it the other way. If it still won't fit, contact a qualified electrician to change the outlet, or use a different one. **Do not attempt to bypass this safety feature.**

SERVICE INFORMATION

This product should be serviced only by those specially trained in appropriate servicing techniques. For instructions on how to obtain service, refer to the warranty included in this Guide.

FOR YOUR RECORDS

According to some state laws, and in the event that service should be required, you may need both the model number and the serial number. In the space below, record the date and place of purchase, and the serial number:

Model No. RS-1247/RS-1248

Remote Control No. CRK291B1

Date of Purchase

Place of Purchase

Serial No.

WARNING: TO PREVENT FIRE OR ELECTRICAL SHOCK HAZARD, DO NOT EXPOSE THIS PRODUCT TO RAIN OR MOISTURE.



TABLE OF CONTENTS

FCC INFORMATION	2
<i>Safety Precautions</i>	2
<i>For Your Safety</i>	2
<i>Service Information</i>	2
<i>For Your Records</i>	2
FIRST THINGS FIRST	4
<i>Unpack the System</i>	4
<i>Check for Moisture</i>	4
<i>Choosing System Location</i>	4
CONNECTIONS	5
<i>Speakers</i>	5
<i>Antennas</i>	5
<i>Power Supply</i>	5
PANEL CONTROLS	6
USING THE TUNER	9
USING THE CD PLAYER	10
<i>Loading Discs</i>	10
<i>Basic Operations</i>	10
USING THE CD PLAYER	11
<i>Programming Play Order</i>	11
<i>Recalling and Editing Programmed Play Order</i>	11
USING THE CD PLAYER	12
<i>Playing and Loading Discs Simultaneously</i>	12
<i>Shuffle Play</i>	12
USING THE CD PLAYER	13
<i>Repeat Play</i>	13
USING THE CASSETTE DECKS	15
<i>Loading Cassette Tapes</i>	15
<i>Basic Operations</i>	15
USING THE CASSETTE DECKS	16
<i>Automatic Tape Stop</i>	16
<i>Dual Decks Tape Play</i>	16
<i>Recordings</i>	16
USING THE REMOTE CONTROL	18
<i>Installing Batteries</i>	18
<i>Remote Control Operations</i>	18
DISPLAY MESSAGES IN CD MODE	21
CARE & MAINTENANCE	22
TROUBLESHOOTING TIPS	24
INDEX	26
US WARRANTY	27
CANADIAN WARRANTY	28

FIRST THINGS FIRST

UNPACK THE SYSTEM

Unpack your new RS-1247 or RS-1248 audio system and locate all the accessories. You should have:

- one RS-1247 or RS-1248 main unit;
- one RCA Remote Control (CRK291B1);
- one pair of speakers (different speakers for different models);
- one external AM loop antenna;
- one RS-1247/RS-1248 user's guide;
- and one safety leaflet.

AM loop antenna

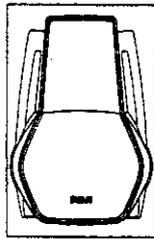

RS-1247 Speakers

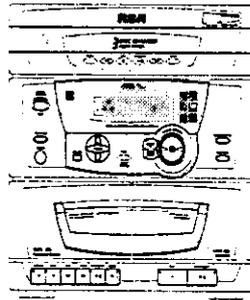
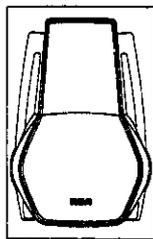

RS-1247/RS-1248
main unit



RS-1248 Speakers

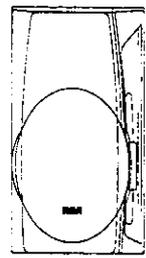

Remote
Control

CHECK FOR MOISTURE

Just as moisture can form on the inside of windows on a cold day, it can also form on the inside of your audio system causing it to malfunction.

If moisture forms inside the system it may not operate properly. In this case the best thing to do is to disconnect power to the unit and wait about 30 minutes for the moisture to evaporate.

CHOOSING SYSTEM LOCATION

It is recommended to follow these guidelines when setting up your system:

- Choose a solid, level surface. Don't place on surfaces like carpet or foam rubber.
- Choose a location away from direct sunlight, radiator, air ducts and sources of heat.
- Avoid locations subject to moisture, mechanical vibration, shock or excessive dust.
- Ensure that the location is adequately ventilated, as it is essential to protect the unit from internal heat build-up.

For optimal listening:

- Speakers should be placed at least three feet apart and facing the listener.
- Speakers should be placed away from the wall to avoid accentuated bass response.

CONNECTIONS

SPEAKERS

If you have purchased our RS-1247, your speakers are identical. If you've selected our RS-1248, you'd find that the physique of the speakers aren't identical, but placing either one on the right and the other on the left won't matter.

Though the speakers for the two models are different, their connections are very much the same. To connect a speaker wire either to the terminals of a speaker or the unit, follow these steps:

1. At the back of a speaker or the unit, press and hold the black tab to open the (-) terminal, fit in the black speaker wire, release hold.
2. Press and hold the red tab to open the (+) terminal, fit in the red speaker wire, release hold.
3. Repeat steps 1 to 2 above for connecting to the speakers and the unit.

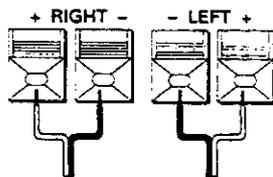

+ & - Terminals at the back of the unit

ANTENNAS

This unit comes with two antennas: an AM loop antenna and a FM T-type antenna. Use the same method of connecting speaker wires to hook the AM loop antenna. To get better reception, try placing it at various locations.

AM Loop Antenna

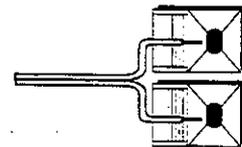
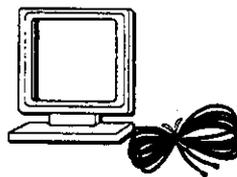

As for the FM T-type antenna, it's already attached to the unit, simply extend it to the full length, then place it at various locations to get clearer reception.

POWER SUPPLY

Plug the power cord into an AC power outlet, be sure to match the wide blade of the plug to the wide slot of the outlet. If the plug doesn't fit in, try plugging it the other way, be sure to plug it in completely.

When the unit is off, the STANDBY light comes on showing that the unit is still plugged to power. To disconnect power completely, unplug the power cord at the AC power outlet, the STANDBY light goes off.

PANEL CONTROLS

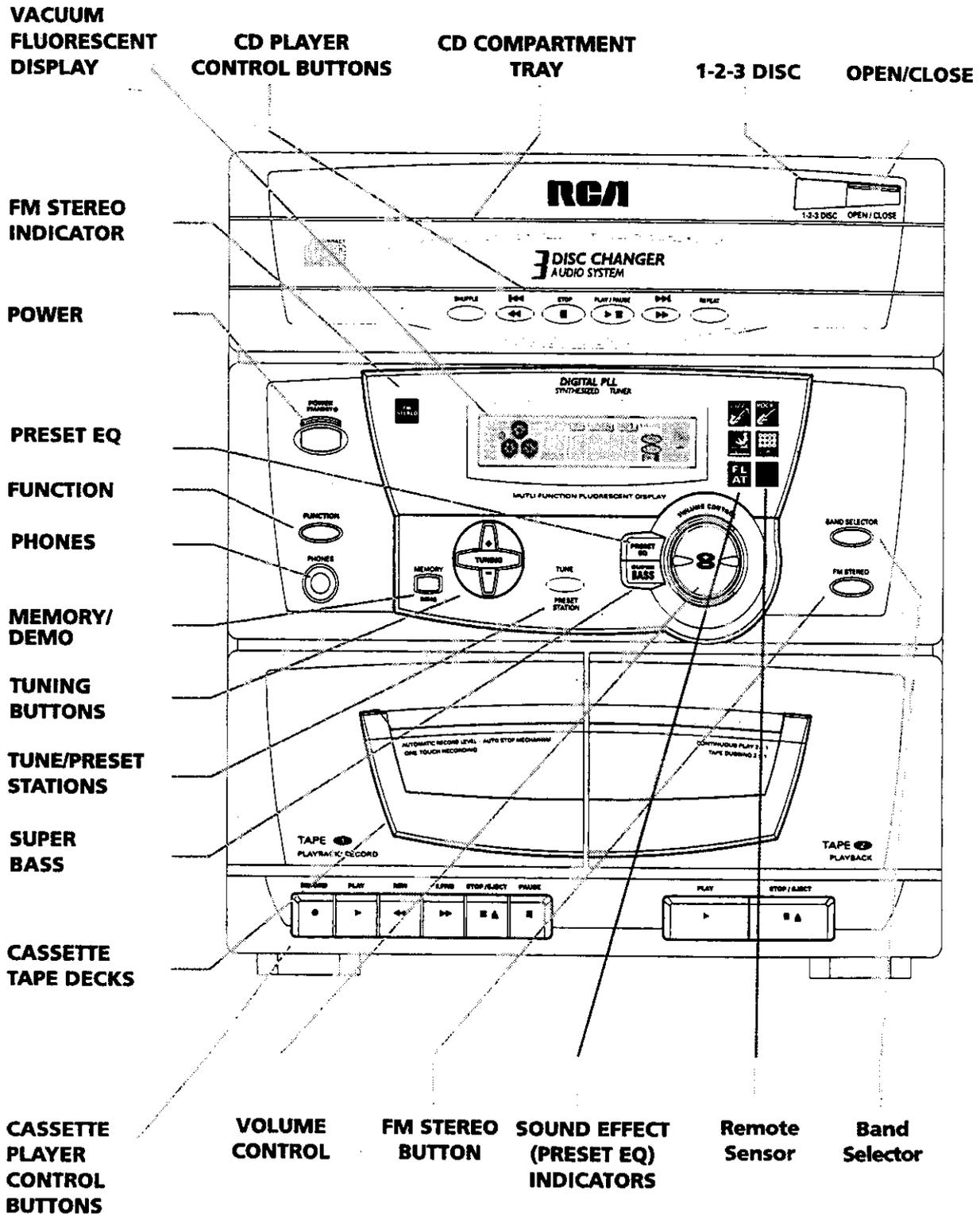

PANEL CONTROLS

VACUUM FLUORESCENT DISPLAY

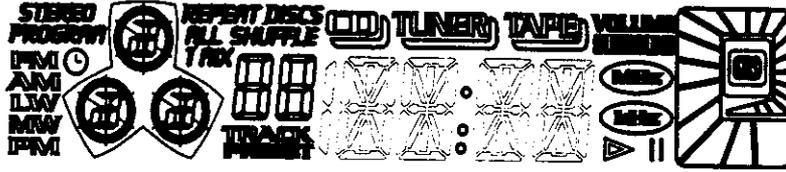

The vacuum fluorescent display (VFD) shows the current status of the unit such as volume level, playing disc number, playing track number, selected play mode, radio frequency, selected Preset EQ, etc.

Further explanation of the display messages will accompany the operational procedures of each function.

CD PLAYER CONTROL BUTTONS

These control buttons are for CD player, they function only in CD mode.

CD COMPARTMENT TRAY

This tray can store 3 CDs at any one time.

1-2-3 DISC

This button's function is for rotating the disc tray to change discs with/without opening the CD Compartment Discs Tray.

OPEN/CLOSE

This button is used for opening and closing the CD Compartment Tray.

FM STEREO INDICATOR

This indicator lights when receiving FM radio in stereo mode.

POWER

To turn on your RS-1247 or RS-1248, press this button. To switch your system to STANDBY mode, press again, the STANDBY indicator light comes on with display showing *STBY*.

PRESET EQ

You can press this button to toggle between 5 preset styles of sound effect (preset equalizers) modes. You have a selection between Jazz, Rock, Classical, Techno, and Flat.

FUNCTION

Press this button to select the 3 functions: Cassette Player, CD Player, and Tuner.

PANEL CONTROLS

PHONES

You can listen to your audio system through a set of headphones (not included). Take note, when a set of headphones is plugged into the system, sound output will divert from the speakers to your set of headphones.

MEMORY/DEMO

In Tuner mode, use MEMORY to store up to 32 preset radio frequencies. In CD mode, use MEMORY to store up to 32 tracks. In Standby mode, press this button to enter display Demonstration mode.

TUNING BUTTONS

The **TUNING +** and **TUNING -** buttons can be used to change radio frequency, select preset stations or select memory locations during station preset.

TUNE/PRESET STATIONS

In Tuner mode, you can store up to 32 preset station frequencies in memory.

SUPER BASS

Select this function to enhance the bass sound effect of heavy-based sound.

CASSETTE TAPE DECKS

Your RS-1247 or RS-1248 is equipped with dual cassette tape decks: one for playback only and one for playback plus recording.

CASSETTE PLAYER CONTROL BUTTONS

All cassette player operations such as Tape Play, Stop, Rewind, Fast Forward, Record, and Tape Eject are at the front panel of the system.

VOLUME CONTROL

Press + to increase sound level, press - to decrease sound level.

FM STEREO BUTTON

When the system is in Tuner mode and FM band, you can press this button and listen to FM radio in stereo mode.

PRESET EQ (SOUND EFFECT) INDICATORS

When you press on the PRESET EQ button repeatedly the indicators light up one by one indicating your choice of the type of sound effect.

BAND SELECTOR

To choose either FM or AM radio band, press on this button to toggle between the two bands (make sure that the system is in Tuner mode).

USING THE TUNER

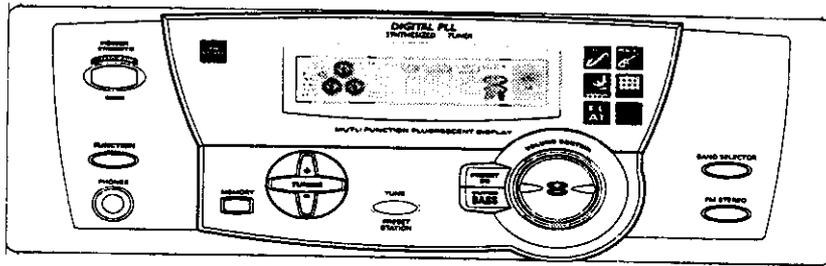

Your system's tuner is very much similar to the usual ones that you'd find in other audio systems. It too has tuning buttons, band selector for choosing between AM and FM radio stations, FM stereo button for stereo effects when listening to FM radio broadcast, plus a Memory button for storing your preset radio frequencies.

TUNER OPERATIONS

1. If the system is not already turned on, press **POWER** to turn system on.
2. Press **FUNCTION** repeatedly until the display shows *Tuner*.
3. Press **BAND SELECTOR** to choose your desired radio band: AM or FM.
4. For tuning to stations manually, press **TUNE PRESET STATION** once or twice so the display does not show *PRESET*.
5. Now press either **TUNING +** or **TUNING -** to select a radio frequency.
6. When listening to FM radio stations, press **FM STEREO** for receiving stereo broadcast.

PRESETTING STATIONS

1. Press **BAND SELECTOR** to choose your desired radio band: AM or FM.
2. If the display shows *PRESET*, press **TUNE PRESET STATION** once so that the display no longer shows *PRESET*.
3. Press either **TUNING +** or **TUNING -** to choose a radio-frequency.
4. Press **MEMORY** to enter program mode, then press either **TUNING +** or **TUNING -** to select a memory location. The display flashes *PRESET*, press **MEMORY** within 5 seconds to set that frequency into the memory location.
5. Repeat steps 1 to 4 in this section to set up to 32 stations into memory.

RECALLING PRESETTING STATIONS

1. Press **TUNE PRESET STATION** once or twice so the display shows *Preset*.
2. Press either **TUNING +** or **TUNING -** to choose one of the preset stations.

USING THE CD PLAYER

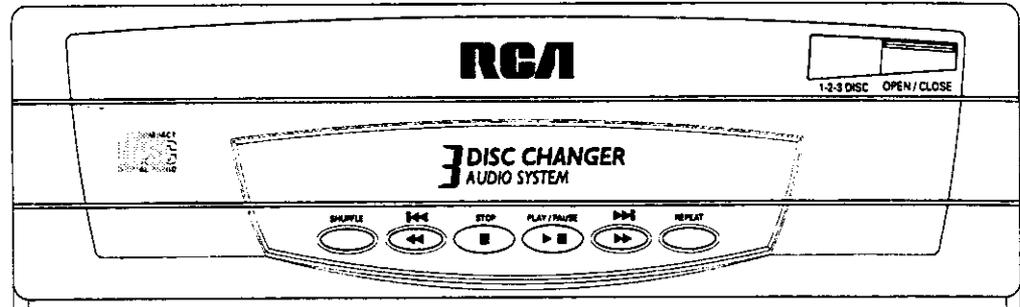

LOADING DISCS

1. Press **POWER** to turn on your RS-1247 or RS-1248.
2. Press **FUNCTION** to select CD mode, the display shows "CD".
3. Press **OPEN/CLOSE** to slide out the CD Compartment Tray.
4. Load one to three CD(s) onto the CD Compartment Tray.
5. Press **1-2-3 DISC** to rotate the tray and place the third disc onto the last vacant position, if so desired.
6. Press **OPEN/CLOSE** to slide the tray back in to the unit.
7. Press **1-2-3 DISC** to select a disc to be played.
8. The display shows "DSC 1" or "DSC 2" or "DSC 3" momentarily. When you've finished your disc selection the display shows "READ". After the system has finished reading the selected disc the display then shows the disc number, total number of tracks on that disc, and total track time of the disc.

BASIC OPERATIONS

1. If discs are not already loaded, follow the above section **LOADING DISCS**.
2. To begin CD play mode, press **PLAY/PAUSE**.
3. To pause disc play momentarily, press **PLAY/PAUSE** again. You can resume to normal disc play by pressing **PLAY/PAUSE** a third time.
4. Return to the beginning of the current playing track by pressing  . To skip backwards to other previous tracks press  repeatedly.
5. Press  for skipping forward to the beginning of the next track. To skip forward to the beginning of other tracks ahead of the current one, press  .
6. To stop disc play completely, press **STOP**.

USING THE CD PLAYER

PROGRAMMING PLAY ORDER

Be sure that the system is in Stop mode prior to setting program play order.

1. If discs are not already loaded, follow the section on **LOADING DISCS**.
2. Press **MEMORY** to enter program mode.
3. Press **1-2-3 DISC** to select a disc.
4. Press  or  to select a track to be placed in memory location 1 (next memory location number for continual programming).
5. Press **MEMORY** to enter selection.
6. Repeat steps 3 to 5 above to program into the other memory locations. You can program up to 32 tracks, when you do program 32 tracks, you'll see the display showing "FULL" after programming the thirty-second track. (For display messages, refer to the **DISPLAY MESSAGES** section on page 21, ten pages ahead in this manual.)
7. Press **PLAY/PAUSE** to start program play.
8. To exit program mode, press **STOP**.

RECALLING AND EDITING PROGRAMMED PLAY ORDER

Again, be sure that the system is in Stop mode prior to recalling or editing programmed play order.

TO RECALL A PROGRAM

1. Press **MEMORY** to enter program mode.
2. To scroll through and check the programmed sequence of tracks, press **MEMORY** repeatedly.
3. To start program play, press **PLAY/PAUSE**.
4. To exit program mode, press **STOP**.

TO EDIT A PROGRAM

1. Press **MEMORY** to enter program mode.
2. Find the memory location by pressing **MEMORY** repeatedly for scrolling to the desired location.
3. Press  or  to select another track for replacing the existing one.
4. Press **MEMORY** to enter selection.
5. To replace other tracks, repeat steps 2 to 4.
6. To start program play, press **PLAY/PAUSE**.
7. To exit program mode, press **STOP**.

USING THE CD PLAYER

PLAYING AND LOADING DISCS SIMULTANEOUSLY

Your 3 Disc Changer Audio System has one other feature that you simply cannot resist; while the system is playing a disc, you can open the CD compartment tray to unload the other 2 discs and re-load 2 new ones without interrupting the playing music.

Let's say if you're playing disc 2 and you want to replace discs 1 and 3 with two other discs. All you'd have to do is press **OPEN/CLOSE** once to slide out the CD compartment tray, unload the two discs you want to replace, reload one or two other discs, then press **OPEN/CLOSE** again to slide the tray back in, and it's done! Now you can listen to the newly loaded discs 1 or 3, just press **1-2-3 DISC** for rotating the tray to different discs.

SHUFFLE PLAY

With this function the system plays the tracks out of its original recorded sequence and you have quite a few choices of how the tracks can be shuffled. You can:

- Repeatedly shuffle play one disc,
- Repeatedly shuffle play all loaded discs,
- Shuffle play the tracks of all discs (playing each track only once) or
- Shuffle play the tracks of one disc (playing each track only once).

Take your pick and follow the steps to set the system playing the way you like.

REPEATEDLY SHUFFLE PLAY WITHIN ONE DISC

1. If discs are not already loaded or selected, follow the section on **LOADING DISCS**.
2. Press **REPEAT** repeatedly until the display shows "*REPEAT 1 DISC*".
3. Press **SHUFFLE** and the display shows "*SHUFFLE*" and begins CD play automatically.

REPEATEDLY SHUFFLE PLAY ALL DISCS

1. If discs are not already loaded or selected, follow the section on **LOADING DISCS**.
2. Press **REPEAT** repeatedly until the display shows "*REPEAT ALL DISCS*".
3. Press **SHUFFLE** and the display shows "*SHUFFLE*" and begins CD play automatically.

USING THE CD PLAYER

SHUFFLE PLAY THE TRACKS OF ALL DISCS

The difference between this mode and the previous one is that with the previous mode, the system continues playing the tracks of all loaded discs repeatedly and CD play mode won't end unless you press Stop. With this mode, it plays each track once for all loaded discs, after all tracks have been played, the system stops CD play mode. Follow the steps below to select this mode:

1. If discs are not already loaded or selected, follow the section on **LOADING DISCS**.
2. Press **REPEAT** repeatedly until the display shows "*ALL DISCS*".
3. Press **SHUFFLE** and the display shows "*SHUFFLE*" and CD play begins automatically.

SHUFFLE PLAY THE TRACKS OF ONE DISC

To shuffle play within one disc only, make sure to load only one disc, otherwise the system will shuffle play all discs. To select this mode, follow the steps below:

1. If discs are not already loaded or selected, follow the section on **LOADING DISCS**.
2. Press **REPEAT** repeatedly until the display shows "*REPEAT 1 DISC*".
3. Press **SHUFFLE** and the display shows "*SHUFFLE*" and CD play begins automatically.

REPEAT PLAY

With this function you can set the system playing one or some tracks over and over. You have the following choices:

- Repeat play - one track,
- Repeat play - one disc,
- Repeat play - all discs,
- Repeat play - program or
- Repeat function off.

Take your pick and follow the steps on the next page to set the system playing the way you like.

USING THE CD PLAYER

REPEAT PLAY - ONE TRACK

To repeat play any one particular track, follow step 5 in **BASIC OPERATIONS** page 10 to skip forward or backwards to that particular track, press **PLAY/PAUSE**, then press **REPEAT** repeatedly until the display shows "*REPEAT 1*". The system will play that track over and over until you press Stop to end CD play.

REPEAT PLAY - ONE DISC

To repeat play a particular disc, press **1-2-3 DISC** for skipping to that particular disc, press **PLAY/PAUSE**, then press **REPEAT** repeatedly until the display shows "*REPEAT 1 DISC*". The system will play that disc over and over until you press Stop to end CD play.

REPEAT PLAY - ALL DISCS

To repeat play all loaded discs, press **PLAY/PAUSE** to start CD play, then press **REPEAT** repeatedly until the display shows "*REPEAT ALL DISCS*". The system will play all loaded disc(s) over and over until you press Stop to end CD play.

REPEAT PLAY - PROGRAM

To repeat play a stored program, press **MEMORY** for entering program mode, press **PLAY/PAUSE**, then press **REPEAT** repeatedly until the display shows "*REPEAT ALL DISCS*". The system will play that program over and over until you press Stop to end CD play.

REPEAT FUNCTION OFF

You can turn the repeat function off by pressing **REPEAT** repeatedly until the display shows "*ALL DISCS*".

USING THE CASSETTE DECKS

Your RS-1247/RS-1248 audio system comes with dual cassette decks. With dual cassette decks you can play cassette tapes one after another. Tape deck 1 can record and playback tapes, while tape deck 2 has only a playback function.

When using cassette tape decks be sure to use the Function button for selecting Tape mode.

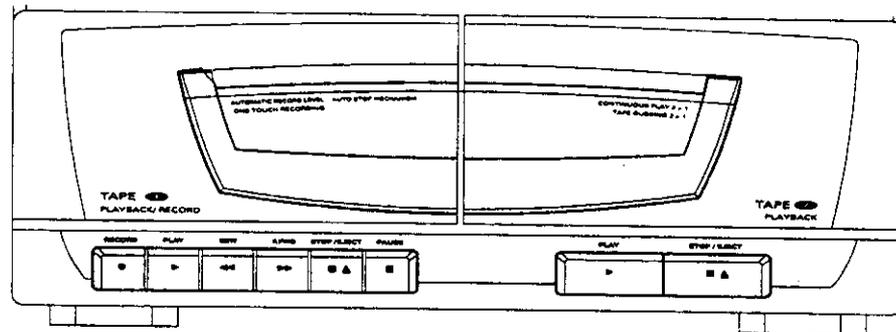

LOADING CASSETTE TAPES

1. Press **POWER** to turn on your RS-1247 or RS-1248.
2. Press **FUNCTION** to select Tape mode, the display shows "TAPE".
3. Press **STOP/EJECT** at either one or both decks to open one or both doors.
4. Insert a tape with its open edge facing downwards.
5. To close a deck door, (for deck 1) lightly push on the top left corner of deck 1's door; (for deck 2) lightly push on the top right corner of deck 2's door.

BASIC OPERATIONS

1. Check that your system is loaded with cassette tape(s) in deck 1 and/or deck 2. If tapes are not already loaded, follow the above section on **LOADING CASSETTE TAPES**.
2. To begin tape play at deck 1, press **PLAY** at deck 1. Tape play at deck 2, press **PLAY** at deck 2.
3. For deck 1, you can rewind or forward wind the tape to the desired position. To rewind, press **REW**. To wind forward, press **F.FWD**.
4. For deck 1 you can also pause tape play temporarily by pressing **PAUSE**. Resume to normal tape play by pressing **PAUSE** again. Since deck 2 has no pause function, use the tape stop function instead by pressing **STOP**.
5. For deck 1, stop tape play completely by pressing **STOP**.

USING THE CASSETTE DECKS

AUTOMATIC TAPE STOP

When a cassette tape is engaged in a particular mode (except Pause mode) and reaches the end of the tape, the tape deck buttons automatically resume to the Off position.

DUAL DECKS TAPE PLAY

Your system can be set to play deck 2 then deck 1 without (prolonged) playback discontinuance.

1. Check that your system is loaded with cassette tapes in both deck 1 and deck 2. If tapes are not already loaded, follow the section on **LOADING CASSETTE TAPES**.
2. Press **PLAY** to start tape play at deck 2.
3. Press **PAUSE** then **PLAY** at deck 1.
4. At this point, deck 2 should be playing. Once deck 2 finishes, it automatically stops, then the system releases pause on deck 1 and starts playing the tape inside deck 1.

RECORDINGS

You have a choice of recording from various sources:

- Recording from radio;
- Recording from the CD player;
- Recording from a cassette tape.

RECORDING FROM RADIO

1. Follow the steps on **LOADING CASSETTE TAPES** to load a completely blank or partially blank tape into deck 1.
2. For partially blank tapes, use Rewind or F.Fwd (forward wind) for winding the tape to the desired starting point.
3. Select Tuner mode by pressing **FUNCTION** repeatedly until the display shows "TUNER".
4. Choose a radio station. Refer to page 9 on **USING THE TUNER**.
5. Press **RECORD** to begin recording from radio.
6. To pause temporarily, press **PAUSE**. Resume recording by pressing **PAUSE** again.
7. To stop recording completely, press **STOP/EJECT**.

USING THE CASSETTE DECKS

RECORDING FROM THE CD PLAYER

1. Follow steps 1 and 2 of the previous section on RECORDING FROM RADIO.
2. Select CD Player mode by pressing **FUNCTION** repeatedly until the display shows "CD".
3. Load one to three CDs into the CD compartment tray, press **1-2-3 DISC** to select the desired disc, then press  or  to select the desired first track you want to record.
4. Quickly press **PLAY/PAUSE** twice to pause CD, avoiding immediate CD play.
5. At deck 1, press **PAUSE** then press **RECORD**.
6. Now...get ready to release both pauses! Put a finger of one hand on the CD player's **PLAY/PAUSE** and put a finger of the other hand on the deck 1's **PAUSE**. Press on both simultaneously to begin recording.

RECORDING FROM A CASSETTE TAPE

1. Follow steps 1 and 2 of the previous section on RECORDING FROM RADIO.
2. Load the pre-recorded tape into deck 2 (this should be the tape that you want to record from).
3. Select Tape mode by pressing **FUNCTION** repeatedly until the display shows "TAPE".
4. At deck 1, press **PAUSE** then press **RECORD**.
5. To begin recording, press **PLAY** at deck 2 and the system automatically releases the Pause on deck 1.
6. To put a pause in the recording, press **PAUSE** at deck 1. To resume recording, press **PAUSE** again.

DON'T INFRINGE !

This product should only be used for the purposes for which it is sold, that is, entertainment, violating no copyright law. Any attempts to use this product for which it is not intended is unlawful and therefore not condoned by Thomson Consumer Electronics.

USING THE REMOTE CONTROL

INSTALLING BATTERIES

The remote control must be inserted with 2 AAA batteries prior use. Follow the steps below to ensure correct installation.

1. Fit the tip of your index finger into **A**, slightly push the tab of the battery compartment lid towards direction **B**, lightly lift upwards to detach the lid.
2. Before inserting the batteries, observe the polarities (that is, **+** and **-**) of the batteries, then relate the polarities to the engraved diagram inside the battery compartment. Now insert the batteries.
3. After installation of the batteries, replace and fit the lid to cover the batteries. Lightly push it close. You should hear a small "CLICK" sound from the closing of the tab.

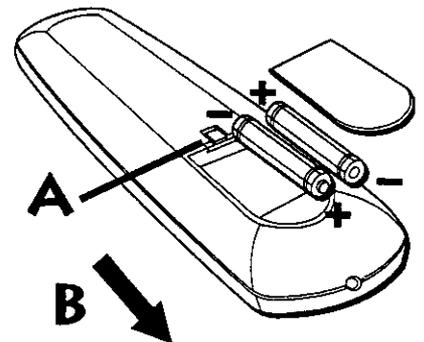

REMOTE CONTROL OPERATIONS

1. Press **POWER** to turn on system.
2. To select one of the available modes: Tuner, CD or Tape, press **TUNER** or **CD** or **TAPE**.
*Note: The **RECORD** button on the remote control is inactive for this model.*
3. To see a display demonstration of the system, press **DEMO**.
4. To turn off system, press **POWER** again.

FOR SOUND EFFECT AND VOLUME ADJUSTMENTS

1. Press **SUPER BASS** to enhance heavy-based sound.
2. To select one of the five preset sound effects, press **PRESET EQ** repeatedly to toggle between the five Preset EQ (Preset Equalizers): Jazz, Rock, Classical, Techno, Flat.
3. Press **MUTE** to silence the sound output. Resume to normal by pressing **MUTE** again.
4. Adjust the sound output level by pressing **VOL +** to increase or **VOL -** to decrease.

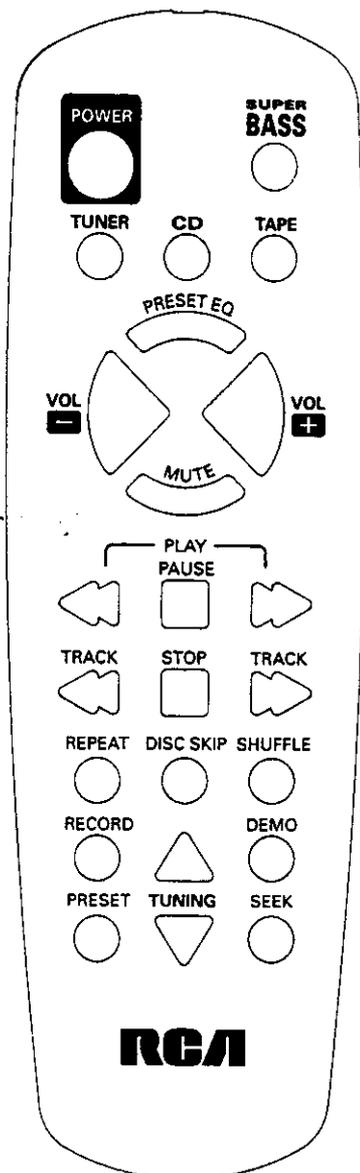

USING THE REMOTE CONTROL

IF YOU SELECT TUNER:

1. Search for a radio station automatically by pressing **SEEK** and the system searches for the next frequency with enough signal strength.
2. To stop auto Seek, press either one of the **TUNING** arrows (▲ or ▼).
3. Search for a radio station manually by pressing either one of the **TUNING** arrows (▲ or ▼).
4. Select a preset radio station frequency by pressing **PRESET** to enter Preset mode, press either one of the **TUNING** arrows (▲ or ▼) to choose a preset memory location.

IF YOU SELECT CD:

1. Select a CD by pressing **DISC SKIP** repeatedly to toggle between and choose one of the loaded discs.
2. Press  (PLAY) to start disc play from the beginning of track 1 of selected disc.
3. To skip forward or backward to the beginning of other tracks, press  (TRACK) or  (TRACK).
4. For fast search forward or backward within a playing track, press and hold either  (TRACK) or  (TRACK). Release hold on button when the fast search reaches your desired search place.
5. You can pause disc play at any one point, just press **PAUSE**. Release pause by pressing  (PLAY).
6. To stop disc play, press **STOP**.

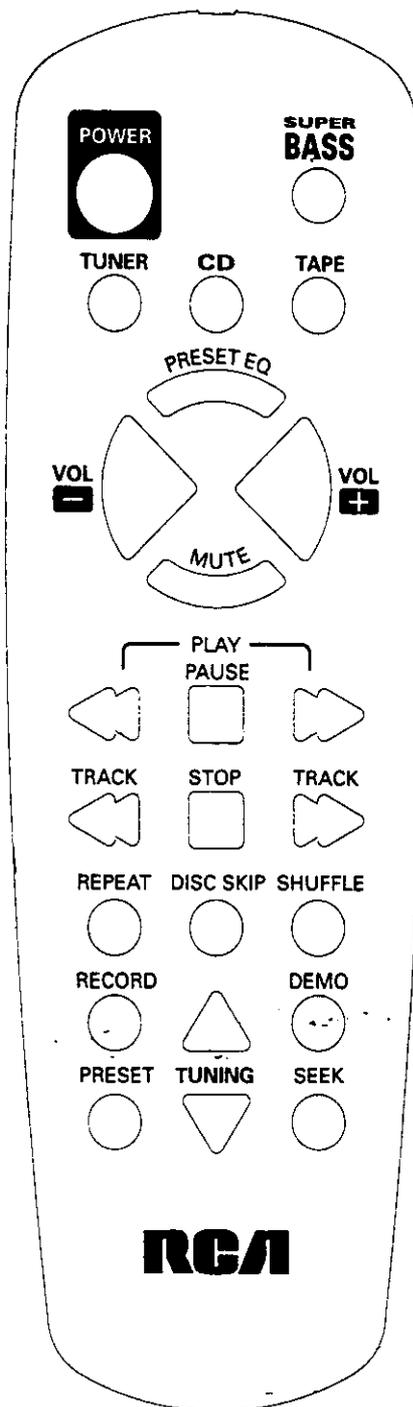

USING THE REMOTE CONTROL

7. The Repeat function is for repeating disc or track play. Press **REPEAT** repeatedly to toggle between and select one of the modes: repeat one track, repeat one disc, repeat all loaded disc(s). During selection, be sure to look at the display to see the changing of modes, stop pressing when the display shows your desired mode.
8. Choosing the Shuffle function will set the system playing tracks in a shuffled sequence. Press **SHUFFLE** once and the display shows *SHUFFLE*. Press **SHUFFLE** again for resuming to normal disc play. The functionality of Shuffle is also dependent on the selected Repeat mode. If the Repeat One Disc mode is selected, then tracks will be shuffle-played within that one disc, repeatedly. If the Repeat All Discs mode is selected, tracks of all discs will be shuffle-played, repeatedly. If the mode All Discs is selected, the system will shuffle-play all discs, play each track once, and returns to Stop mode.

IF YOU SELECT TAPE:

You will need to perform all Tape mode related operations at the front panel of the system. Remote control of Tape mode functions is not possible since the decks are not Logic Decks.

DISPLAY MESSAGES IN CD MODE

The following are some of the messages you may see when the system is in CD mode. Refer to the descriptions below when you see a message on display.

This message is displayed when:

<i>STBY</i>	the system is in Standby mode.
<i>OPEN</i>	the CD compartment tray is opening.
<i>CL</i>	the CD compartment tray is closing.
<i>READ</i>	the system is reading the content of a disc.
<i>MUTE</i>	the Mute function is activated. Also refer to page 18, step 3 of section For Sound Effect and Volume Adjustments for a more detailed functional explanation.
<i>ERR</i>	the CD compartment tray is obstructed as it opens or closes. Press OPEN/CLOSE to re-open or re-close the CD compartment tray. This cancels the error.
<i>FULL</i>	the system's (CD mode) track memory has reached its limit and cannot store any more tracks.
<i>CLR</i>	you clear a stored program. In program mode, press and hold STOP for about 1 second, the display shows this message to indicate that the program is being cleared.
<i>EMP</i>	you try to select program play while no program has been stored in memory.

CARE & MAINTENANCE

CLEANING THE EXTERIOR

Prior to cleaning the exterior, be sure to unplug the power cord from the AC power outlet. Wipe the exterior with a soft, clean, and slightly water-dampened cloth.

CD CARE

HANDLING CDs :

- Always handle CDs by their edges or hold it with your index finger in the hole and a thumb at one edge. Do not put your finger pads onto the signal (shiny) side of a disc.
- The label side of a disc should be left as is; should not affix any adhesive tapes or labels nor should there be any scratching or damage done to it.
- Never use any damaged (such as cracked or warped) discs as the system spins CDs at very high speed.

CLEANING CDs :

- CDs need to be cleaned regularly because any dust or foreign particles may cause the system to output poor sound quality. To clean a CD, use a soft clean cloth to wipe the CD from the hole (at the center of the disc) outwards to the disc's edge.
- If a CD is particularly dirty, wet a soft cloth in clean water, wring it out to rid the cloth of excess water, gently wipe away the dirt. Use another dry cloth to soak up remaining water droplets.
- Cleaning liquids other than clean water can damage a CD. Never use cleaning sprays, antistatic agents, benzene, thinner, nor any other volatile solvents to clean CDs.

CD LENS CARE

When your CD lens gets dirty it can also cause the system to output poor sound quality. To clean the lens you will need to purchase a CD lens cleaner which can maintain the output sound quality of your system. For instructions on cleaning the CD lens, refer to the ones accompanying the lens cleaner.

CARE & MAINTENANCE

TAPE TYPE SELECTION

In today's hypermarkets and stores there are 3 types of cassette tape available for sale: Type I, Type II, Type III. When you purchase new cassette tapes be sure to select Type I because both Type II and Type III are not suitable for use with this system and may cause poor sound quality.

TAPE CARE

STORING TAPES :

- High temperatures such as exposure to sunlight or storage in hot places may warp the tape's case or damage the tape itself.
- Always keep a cassette tape in its box when not in use.
- Keep cassette tapes away from magnets to avoid erasure by magnetic fields. For example, electric motors and electrical transformers are some of the objects that can erase the content of a cassette tape.

CLEANING HEADS :

- The tape head is the part that plays the music on your tape. Since the tape head comes into contact with magnetic tapes the most, iron oxide particles from the tape builds up on the tape head. This build up can cause muffled playback sound, incomplete recordings, and may prevent automatic tape stop.
- You will need to clean the heads regularly, after every 25 hours of use.
- To clean the heads, unplug the power cord from the power outlet, open the deck door, push down the **PLAY** button to expose the heads. Then use a head cleaner to clean the heads, capstan, and pinch wheel. After cleaning, allow about 30 minutes for the heads to dry prior use.
- From time to time, use a head demagnetizing cassette to demagnetize the head (available from most audio equipment stores).
- Never use any metal objects on or near the tape heads.
- Make sure no cleaning material is allowed to fall into the tape assembly.

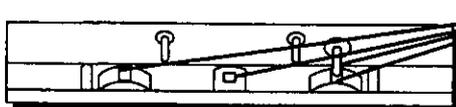

Clean these parts

TROUBLESHOOTING TIPS

SYSTEM DOESN'T TURN ON

- Check your power source, is the power plug fitted and plugged into the power outlet properly, are the batteries in the remote control fresh? If not, do make sure that the power plug is properly plugged in and that the batteries are replaced with fresh ones.
- Unplug the power cord from the power outlet for a moment, then plug it back in again.
- Is there power at that particular power outlet? Try plugging the system to another power outlet.

No SOUND

- Try adjusting the volume level.
- Are the speaker wires properly connected? If not, re-connect the speaker wires properly.
- Is the Mute function activated? If it is, try de-activating the Mute function.
- Make sure you've selected the correct mode: Tape, CD or Tuner.

No SOUND FROM ONE CHANNEL

- Is the connection of that channel's (Left or Right) speaker wire proper? If it's not or you're not certain whether if it is, do reconnect it.

POOR RADIO RECEPTION

- Poor AM or FM reception? AM, adjust the AM loop antenna. FM, adjust the FM T-type antenna.
- Are there electrical appliances near the system (appliances such as hair dryers, vacuum cleaners, or fluorescent lights)? If there are, try turning them off.

CD DOESN'T PLAY

- Is there a disc loaded on the tray? If not, do load one.
- Is the disc's label facing up? If it isn't, turn the disc over and try disc play again.
- Is the Pause mode activated? If yes, de-activate the mode.
- Is the CD function selected? If not, press **FUNCTION** repeatedly until "CD" is displayed.

TROUBLESHOOTING TIPS

CD SOUND SKIPS

- Is the CD dirty? If it is, clean it by following the instructions on page 22.
- Is the disc warped, scratched or cracked? If the disc is damaged in any way don't attempt to play that disc as it may cause damage to the CD lens.
- Is there shock or vibration affecting the system? If so, you should re-locate the system to some other firm, level and stable surface.

DISTORTED OR NOISY RECORDINGS

- Are the tape heads dirty? If they are (or if you're not sure), follow the instructions on page 23 to clean the tape heads.
- Have the tape heads been magnetized? If yes (or if you're not sure), purchase a Head Demagnetizing Cassette which should be available from most audio equipment stores.

REMOTE CONTROL WON'T WORK

- Is the system plugged into a working AC outlet? Try plugging it into one that you know will work.
- Is the system on? Press **POWER** to turn system on.
- Have you selected the correct function when pressing on the buttons? For example, if the system is in CD mode and you try tuning to a particular radio frequency, the remote control is not going to look like it's working. In such cases, press **FUNCTION** to select the correct function first, then press on the buttons.
- Are the batteries weak? Try replacing old batteries with some fresh ones. (Refer to page 18 for instructions on replacing batteries.)
- Are you pointing the remote control directly at the system while pressing the buttons? You should be, because the remote control sensor at the system is right next to the Preset EQ indicators at the right corner of the display.
- Are you too far from the system when using the remote control? The remote control sensor can only sense signals (from the remote control) within a limited distance. So move closer towards the system.
- Are there any obstacles between the remote control and the system? If there are, move all objects standing in the way between the remote control and the system.

INDEX

A

Antennas 5
Automatic Tape Stop 16

B

Band Selector 8

C

Care & Maintenance 22, 23
Cassette Player Control Buttons 8
Cassette Tape Decks 8
CD Care 22
CD Compartment Tray 7
CD Lens Care 22
CD Player Control Buttons 7
Check for Moisture 4
Choosing System Location 4
Connections 5

D

Display Messages in CD Mode 21
Dual Decks Tape Play 16

F

FM Stereo Button 8
FM Stereo Indicator 7
Function 7

I

Installing Batteries (Remote Control) 18

L

Loading Discs (CDs) 10

M

Memo 8

O

Open/Close 7

P

Panel Controls 6, 7, 8
Phones (jack) 8
Playing and Loading CDs Simultaneously 12
Power 7
Power Supply 5
Preset EQ 7
Programming Player Order 11

R

Recalling/Editing Programmed Play Order 11
Recordings 16
Remote Control Operations 18
Repeat Play 13

S

Service Information 2
Shuffle Play 12
Sound Effect (Preset EQ) Indicators 8
Speakers 5
Super Bass 8

T

Tape Care 23
Tape Type Selection 23
Troubleshootin Tips 24, 25
Tune/Preset Stations 8
Tuner Operations 9
Tuning Buttons 8

U

Unpack the System 4
Using the Cassette Decks 15, 16
Using the CD Player 10, 11, 12, 13, 14
Using the Remote Control 18, 19, 20
Using the Tuner 9

V

Vacuum Fluorescent Display 7
Volume Control 8

US WARRANTY

What your warranty covers:

- Any defect in materials or workmanship.

For how long after your purchase:

- One year.

(The warranty period for rental units begins with the first rental or 45 days from date of shipment to the rental firm, whichever comes first.)

What we will do:

- Provide you with a new or, at our option, a refurbished unit.
- The exchange unit is under warranty for the remainder of the original product's warranty period.

How to make a warranty claim:

- Properly pack your unit. Include any cables, etc., which were originally provided with the product. We recommend using the original carton and packing materials.
- Include in the package evidence of purchase date such as the bill of sale. Also print your name and address and a description of the defect. Send standard UPS or its equivalent to:

Thomson Consumer Electronics
Product Exchange Center
11721B Alameda Ave.
Socorro, Texas 79927

- Pay any charges billed to you by the Exchange Center for service not covered by the warranty.
- Insure your shipment in case of loss or damage. Thomson accepts no liability in case of damage or loss.
- A new or refurbished unit will be shipped to you prepaid freight.

What your warranty *does not* cover:

- Customer instruction. (Your Owner's Manual provides information regarding operating instructions and user controls. For additional information, ask your dealer.)
- Installation and set-up service adjustments.
- Batteries.
- Damage from misuse or neglect.
- Products which have been modified or incorporated into other products.
- Products purchased or serviced outside the USA.
- Acts of God, such as but not limited to lightning damage.

Product Registration:

- Please complete and mail the Product Registration Card packed with your unit. It will make it easier to contact you should it ever be necessary. The return of the card is not required for warranty coverage.

How state law relates to this warranty:

- This warranty gives you specific legal rights, and you may have other rights which vary from state to state.

If you purchased your product outside the USA:

- This warranty does not apply. Contact your dealer for warranty information.

CANADIAN WARRANTY

Thomson Consumer Electronics Canada, Inc. warrants to the purchaser or gift recipient that if any manufacturing defect becomes apparent in this product within 1 year from the original date of purchase, it will be replaced free of charge, including return transportation.

This warranty does not include damage to the product resulting from accidents, misuse or leaking batteries.

Should your product not perform properly during the warranty period, either:

1. Return it to the selling dealer with proof of purchase for replacement,
OR
2. Remove the batteries (where applicable), and pack product complete with accessories in the original carton (or equivalent).

Mail prepaid (with proof of purchase) and insured to:

**Thomson Consumer Electronics Canada, Inc.
Distribution Centre
7400 A Bramalea Road
Mississauga, Ontario L5S 1X1**

The provisions of this written warranty are in addition to and not a modification of or subtraction from the statutory warranties and other rights and remedies contained in any applicable legislation, and to the extent that any such provisions purport to disclaim, exclude or limit any such statutory warranties and other rights and remedies, such provisions shall be deemed to be amended to the extent necessary to comply therewith.

If you are unable to find a qualified servicer for out of warranty service, you may write to:

Thomson Consumer Electronics Canada, Inc.
P.O. Box 0944
Indianapolis, Indiana, U.S.A., 46206-0944

Attach your sales receipt to this booklet for future reference. This information is required if service is needed during the warranty period.

PURCHASE DATE _____
NAME OF STORE _____

Model RS-1247/RS-1248
55005530 (E Rev. 0)
98-47 TAHK dn
Printed in the U.S.A.

 **THOMSON CONSUMER ELECTRONICS**
P.O. Box 1976, Indianapolis, IN 46201
© 1998 Thomson Consumer Electronics, Inc.
Trademark(s) ® Registered