

Owner's Manual

**CRAFTSMAN®**

**3.75 HP**

**17 INCH TINE WIDTH**

**FRONT TINE**

**TILLER**

Model No.

**917.292381**

- **Safety**
- **Assembly**
- **Operation**
- **Maintenance**
- **Español**
- **Repair Parts**

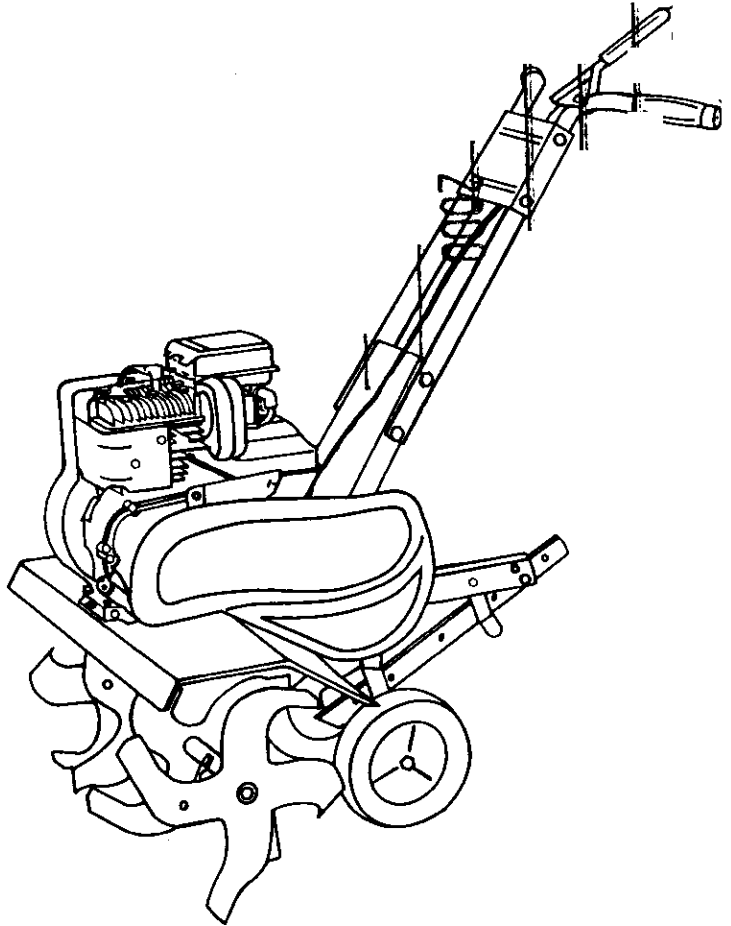

This product has a low emission engine which operates differently from previously built engines. Before you start the engine, read and understand this Owner's Manual.

**CAUTION:**

Read and follow all Safety Rules and Instructions before operating this equipment.

Sears, Roebuck and Co., Hoffman Estates, IL 60179

Visit our Craftsman website: [www.sears.com/craftsman](http://www.sears.com/craftsman)

# TABLE OF CONTENTS

Warranty .....	2	Maintenance .....	11
Safety Rules .....	2	Service and Adjustments .....	13
Product Specifications .....	4	Storage .....	3&16
Assembly .....	5	Troubleshooting .....	17
Operation .....	3&7	Illustrated Parts List .....	36
		Parts Ordering .....	Back Cover

## WARRANTY

### LIMITED ONE YEAR WARRANTY ON CRAFTSMAN TILLER

For one (1) year from date of purchase, when this Craftsman Tiller is maintained, lubricated, and tuned up according to the operating and maintenance instructions in the owner's manual, Sears will repair free of charge any defect in material or workmanship. This Warranty does not cover:

- Expendable items which become worn during normal use, such as tines, spark plugs, air cleaners and belts.
- Repairs necessary because of operator abuse or negligence, including bent crankshafts and the failure to maintain the equipment according to the instructions contained in the owner's manual.
- If this Craftsman Tiller is used for commercial or rental purposes, this Warranty applies for only thirty (30) days from the date of purchase.

Warranty service is available by returning the craftsman power mower to the nearest sears service center/department in the united states. This warranty applies only while this product is in use in the united states.

This Warranty gives you specific legal rights, and you may also have other rights which vary from state to state.

SEARS, ROEBUCK AND CO., D/817WA, HOFFMAN ESTATES, IL 60179

## SAFETY RULES

**IMPORTANT:** This cutting machine is capable of amputating hands and feet and throwing objects. Failure to observe the following safety instructions could result in serious injury or death.

### TRAINING

- Read the Owner's Manual carefully. Be thoroughly familiar with the controls and the proper use of the equipment. Know how to stop the unit and disengage the controls quickly.
- Never allow children to operate the equipment. Never allow adults to operate the equipment without proper instruction.
- Keep the area of operation clear of all persons, particularly small children, and pets.

### PREPARATION

- Thoroughly inspect the area where the equipment is to be used and remove all foreign objects.

- Disengage all clutches and shift into neutral before starting the engine (motor).
- Do not operate the equipment without wearing adequate outer garments. Wear footwear that will improve footing on slippery surfaces.
- Handle fuel with care; it is highly flammable.
- Use an approved fuel container.
- Never add fuel to a running engine or hot engine.
- Fill fuel tank outdoors with extreme care. Never fill fuel tank indoors.
- Replace gasoline cap securely and clean up spilled fuel before restarting.
- Use extension cords and receptacles as specified by the manufacturer for all units with electric drive motors or electric starting motors.

- Never attempt to make any adjustments while the engine (motor) is running (except where specifically recommended by manufacturer).

## **OPERATION**

- Do not put hands or feet near or under rotating parts.
- Exercise extreme caution when operating on or crossing gravel drives, walks, or roads. Stay alert for hidden hazards or traffic. Do not carry passengers.
- After striking a foreign object, stop the engine (motor), remove the wire from the spark plug, thoroughly inspect the tiller for any damage, and repair the damage before restarting and operating the tiller.
- Exercise caution to avoid slipping or falling.
- If the unit should start to vibrate abnormally, stop the engine (motor) and check immediately for the cause. Vibration is generally a warning of trouble.
- Stop the engine (motor) when leaving the operating position.
- Take all possible precautions when leaving the machine unattended. Disengage the tines, shift into neutral, and stop the engine.
- Before cleaning, repairing, or inspecting, shut off the engine and make certain all moving parts have stopped. Disconnect the spark plug wire, and keep the wire away from the plug to prevent accidental starting. Disconnect the cord on electric motors.
- Do not run the engine indoors; exhaust fumes are dangerous.
- Never operate the tiller without proper guards, plates, or other safety protective devices in place.
- Keep children and pets away.
- Do not overload the machine capacity by attempting to till too deep at too fast a rate.
- Never operate the machine at high speeds on slippery surfaces. Look behind and use care when backing.
- Never allow bystanders near the unit.
- Use only attachments and accessories approved by the manufacturer of the tiller.

- Never operate the tiller without good visibility or light.
- Be careful when tilling in hard ground. The tines may catch in the ground and propel the tiller forward. If this occurs, let go of the handlebars and do not restrain the machine.

## **MAINTENANCE AND STORAGE**

- Keep machine, attachments, and accessories in safe working condition.
- Check shear pins, engine mounting bolts, and other bolts at frequent intervals for proper tightness to be sure the equipment is in safe working condition.
- Never store the machine with fuel in the fuel tank inside a building where ignition sources are present, such as hot water and space heaters, clothes dryers, and the like. Allow the engine to cool before storing in any enclosure.
- Always refer to the operator's guide instructions for important details if the tiller is to be stored for an extended period.

**⚠** Look for this symbol to point out important safety precautions. It means **CAUTION!!! BECOME AWARE!!! YOUR SAFETY IS INVOLVED.**

**⚠ CAUTION:** Always disconnect spark plug wire and place wire where it cannot contact spark plug in order to prevent accidental starting when setting up, transporting, adjusting or making repairs.

**⚠ WARNING:** The engine exhaust from this product contains chemicals known to the State of California to cause cancer, birth defects or other reproductive harm.

## PRODUCT SPECIFICATIONS

GASOLINE CAPACITY:	2 QTS UNLEADED REGULAR
OIL(API-SF/SG/SH): (CAPACITY: 20 OZ.)	SAE 30 (ABOVE 32°F) SAE 5W-30 (BELOW 32°F)
SPARK PLUG : (GAP: .030")	CHAMPION RJ19LM OR J19LM

**Congratulations** on your purchase of a Sears Tiller. It has been designed, engineered and manufactured to give you the best possible dependability and performance.

Should you experience any problems you cannot easily remedy, please contact your nearest authorized Sears Service Center/Department. We have competent, well-trained technicians and the proper tools to service or repair this unit.

Please read and retain this manual. The instructions will enable you to assemble and maintain your tiller properly. Always observe the "SAFETY RULES".

Your new tiller has been assembled at the factory with exception of those parts left unassembled for shipping purposes. To ensure safe and proper operation of your tiller all parts and hardware you assemble must be tightened securely. Use the correct tools as necessary to insure proper tightness.

## CUSTOMER RESPONSIBILITIES

- Read and observe the safety rules.
- Follow a regular schedule in maintaining, caring for and using your tiller.
- Follow the instructions under the "Maintenance" and "Storage" sections of this Owner's Manual.





**⚠ WARNING:** This unit is equipped with an internal combustion engine and should not be used on or near any unimproved forest-covered, brush-covered or grass covered land unless the engine's exhaust system is equipped with a spark arrester meeting applicable local or state laws (if any). If a spark arrester is used, it should be maintained in effective working order by the operator.

In the state of California the above is required by law (Section 4442 of the California Public Resources Code). Other states may have similar laws. Federal laws apply on federal lands. See your Sears Authorized Service Center for spark arrester. Refer to the Repair Parts section of this manual for part number.



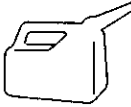

## ACCESSORIES

These accessories were available when the tiller was purchased. They are also available at most Sears Retail outlets and Service Centers. Most Sears Stores can order repair parts for you when you provide the model number of your tiller.

### ENGINE

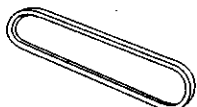
SPARK PLUG	MUFFLER	AIR FILTER	GAS CAN	ENGINE OIL	STABILIZER
					

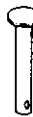
### TILLER MAINTENANCE

BELT	TINES	SHEAR PIN	HAIRPIN CLIP
			

# ASSEMBLY

Your new tiller has been assembled at the factory with exception of those parts left unassembled for shipping purposes. To ensure safe and proper operation of your tiller all parts and hardware you assemble must be tightened securely. Use the correct tools as necessary to insure proper tightness.

## TOOLS REQUIRED FOR ASSEMBLY

A socket wrench set will make assembly easier. Standard wrench sizes are listed.

- (1) Utility knife
- (1) Pair of pliers
- (2) 1/2 Wrench

## OPERATOR'S POSITION

When right or left hand is mentioned in this manual, it means when you are in the operating position (standing behind tiller handles).

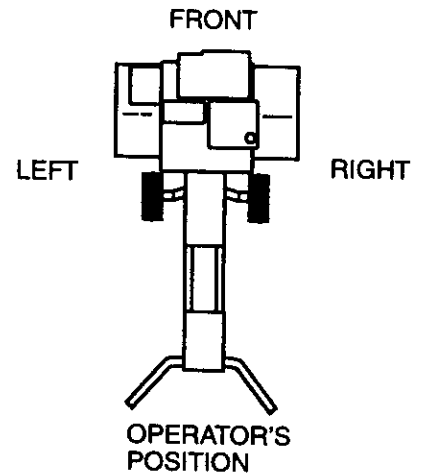

## CONTENTS OF HARDWARE PACK

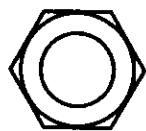
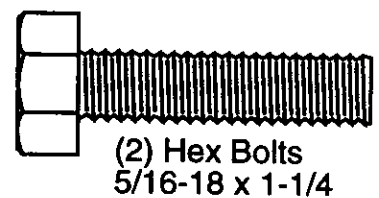
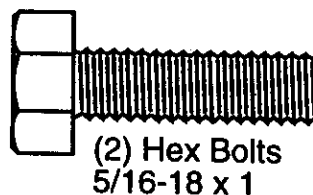
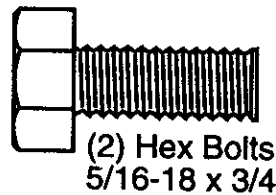

(6) Hex Nuts  
5/16-18



(1) Bottle  
Engine Oil

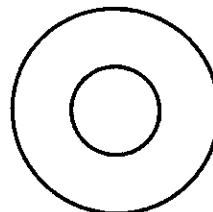

(4) Washers  
3/8 x 7/8 x 14 Ga.



(6) Lock  
Washers 5/16

## UNPACK CARTON & INSTALL HANDLE

**CAUTION:** Be careful of exposed staples when handling or disposing of cartoning material.

**IMPORTANT:** When unpacking and assembling tiller, be careful not to stretch or kink cable(s).

- Cut cable ties securing handles.
- The handle may be assembled in high or low position. Slowly lift handle assembly up and align handle holes with desired handle panel hole and slot.
- Loosely assemble hardware as shown. Be sure the shorter (3/4" long) hex bolt is assembled in lower hole of handle. Repeat for opposite side. Tighten all hardware securely.
- Cut cable ties securing tiller to skid and remove tiller from skid.

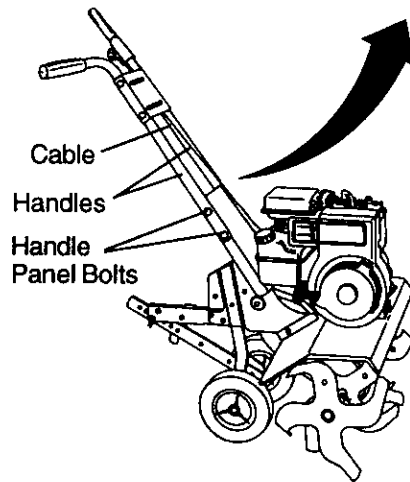
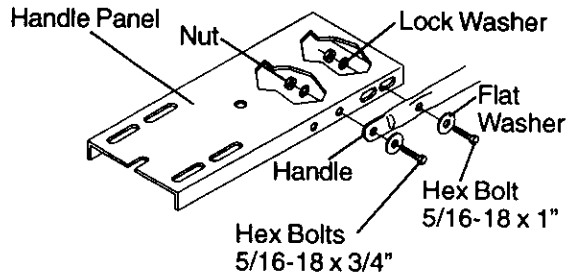

## INSTALL DEPTH STAKE ASSEMBLY

- Loosen nut "A".
- Insert stake support between engine bracket halves with stake spring down.
- Bolt stake support to engine brackets with bolts, lock washers and nuts. Tighten securely. Tighten nut "A".
- Depth stake must move freely. If it does not, loosen support bolt.

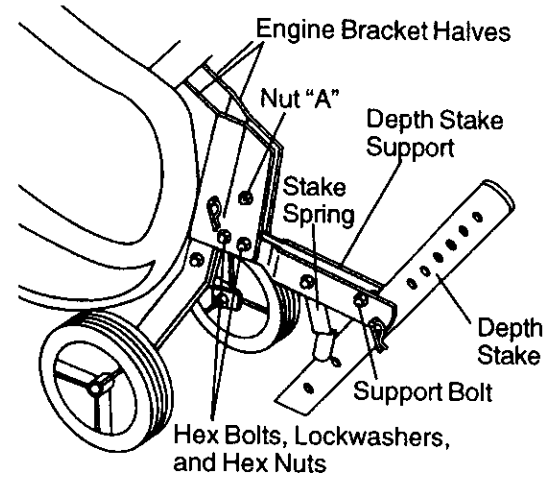

## HANDLE HEIGHT

- Handle height may be adjusted to better suit operator. (See "HANDLE HEIGHT" in the Service and Adjustments section of this manual).

## TILLING WIDTH

- Tilling width may be adjusted to better handle your tilling conditions (See "TINE ARRANGEMENT" in the Service and Adjustments section of this manual).

## TINE OPERATION

- Check tine operation before first use. (See "TINE OPERATION CHECK" in the Service and Adjustments section of this manual).

# OPERATION

These symbols may appear on your Tiller or in literature supplied with the product. Learn and understand their meaning.

## KNOW YOUR TILLER

READ THIS OWNER'S MANUAL AND SAFETY RULES BEFORE OPERATING YOUR TILLER.

Compare the illustrations with your tiller to familiarize with the location of various controls and adjustments. Save this manual for future reference.

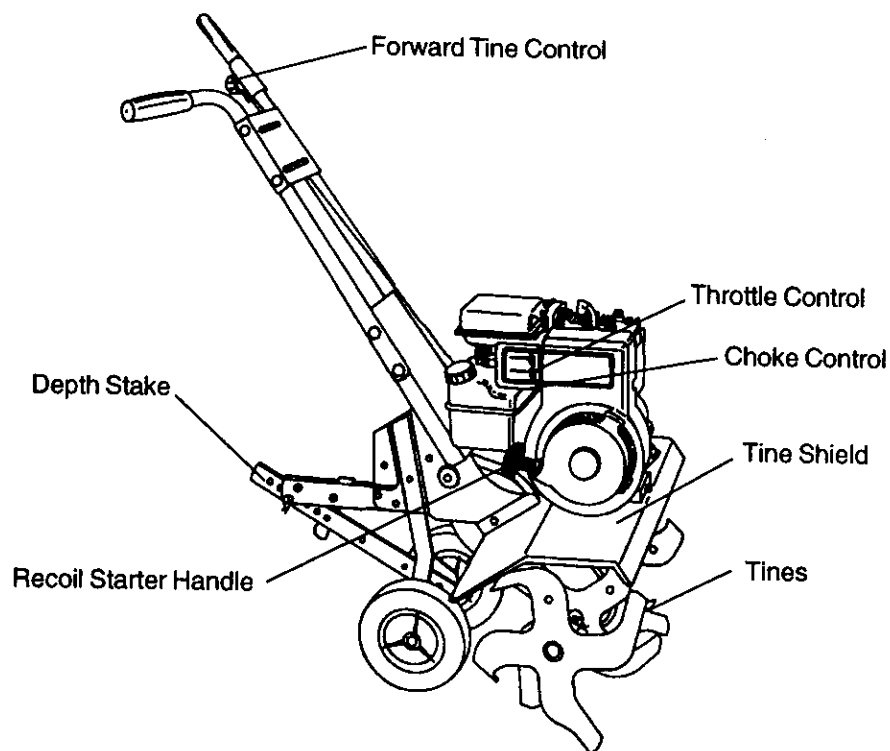
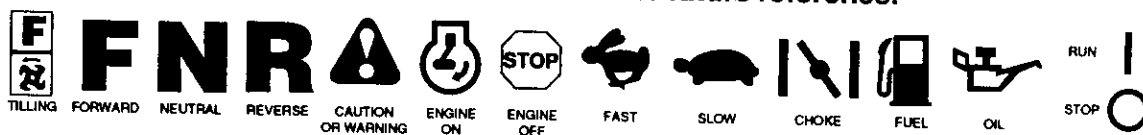

### MEETS ANSI SAFETY REQUIREMENTS

Our tillers conform to the safety standards of the American National Standards Institute.

**FORWARD TINE CONTROL** - Engages tines in forward direction.

**CHOKE CONTROL** - Used when starting a cold engine.

**THROTTLE CONTROL** - Controls engine speed.

**DEPTH STAKE** - Controls forward speed and the depth at which the tiller will dig.

**RECOIL STARTER HANDLE** - Used to start the engine.



The operation of any tiller can result in foreign objects thrown into the eyes, which can result in severe eye damage. Always wear safety glasses or eye shields before starting your tiller and while tilling. We recommend a wide vision safety mask over spectacles or standard safety glasses.

## HOW TO USE YOUR TILLER

Know how to operate all controls before adding fuel and oil or attempting to start engine.

## STOPPING

### TINES

- Release tine control to stop movement.

### ENGINE

- Move throttle control to "STOP" position.
- Never use choke to stop engine.

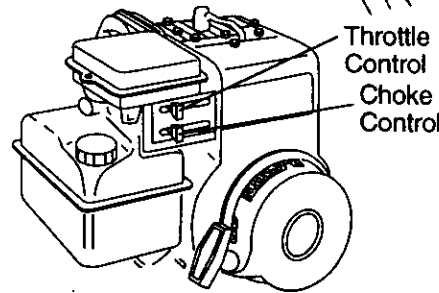
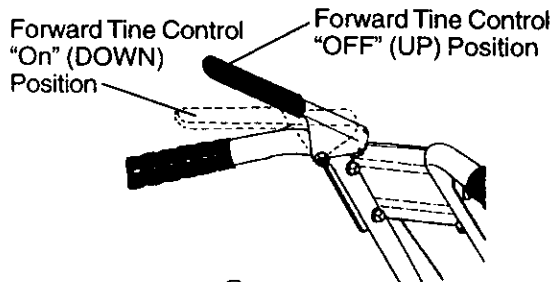

## TINE OPERATION

- Squeeze tine control to handle.

## TILLING

The speed and depth of tilling is regulated by the position of the depth stake and wheel height.

The depth stake should always be below the wheels for digging. It serves as a brake to slow the tiller's forward motion to enable the tines to penetrate the ground. Also, the more the depth stake is lowered into the ground the deeper the tines will dig.

## DEPTH STAKE

Adjust depth stake by removing the hairpin clip and clevis pin. Change depth stake to desired position. Replace the clevis pin and hairpin clip.

- For normal tilling, set depth stake at the second or third hole from the top.

## WHEELS

Adjust wheels by removing the hairpin clip and clevis pin. Change wheel position. Replace the hairpin clip and clevis pin.

- For normal tilling, set wheels at the second or third hole from the top.

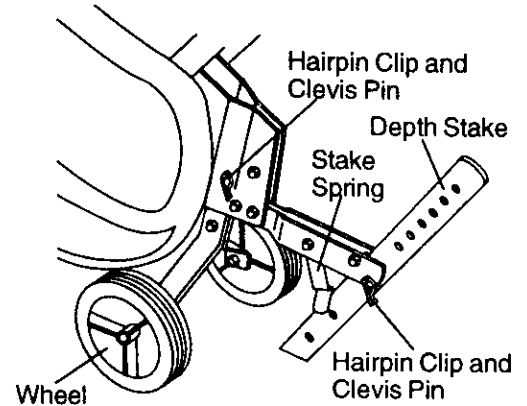

## TO TRANSPORT

**CAUTION:** Before lifting or transporting, allow tiller engine and muffler to cool. Disconnect spark plug wire. Drain gasoline from fuel tank.

### AROUND THE YARD

- Tip depth stake forward until it is held by the stake spring.
- Push tiller handles down, raising tines off the ground.
- Push or pull tiller to desired location.

### AROUND TOWN

- Disconnect spark plug wire.
- Drain fuel tank.
- Transport in upright position to prevent oil leakage.

## BEFORE STARTING ENGINE

**IMPORTANT:** Be very careful not to allow dirt to enter the engine when checking or adding oil or fuel. Use clean oil and fuel and store in approved, clean, covered containers. use clean fill funnels.

### FILL ENGINE WITH OIL

- Remove hangtag from engine.
- With engine level, remove engine oil filler plug.
- Fill engine with oil to point of overflowing. For approximate capacity see "PRODUCT SPECIFICATIONS".
- Tilt tiller back on its wheels and then re-level.



- With engine level, refill to point of overflowing if necessary. Replace oil filler plug.
- For cold weather operation you should change oil for easier starting (See "OIL VISCOSITY CHART" in the Maintenance section of this manual).
- To change engine oil, see the Maintenance section of this manual.

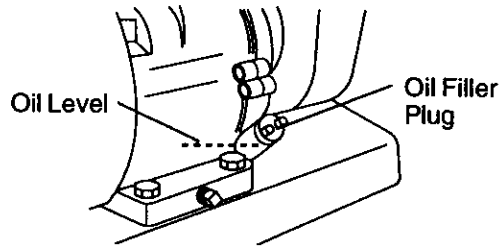

### ADD GASOLINE

- Fill fuel tank. Use fresh, clean, regular unleaded gasoline. (Use of leaded gasoline will increase carbon and lead oxide deposits and reduce valve life.)

**IMPORTANT:** When operating in temperatures below 32°F(0°C), use fresh, clean, winter grade gasoline to help insure good cold weather starting.

**⚠WARNING:** Experience indicates that alcohol blended fuels (called gasohol or using ethanol or methanol) can attract moisture which leads to separation and formation of acids during storage. Acidic gas can damage the fuel system of an engine while in storage. **To avoid engine problems, the fuel system should be emptied before storage of 30 days or longer.** Drain the gas tank, start the engine and let it run until the fuel lines and carburetor are empty. **Use fresh fuel next season.** See Storage section of this manual for additional information. Never use engine or carburetor cleaner products in the fuel tank or permanent damage may occur.

**⚠CAUTION:** Fill to within 1/2 inch of top of fuel tank to prevent spills and to allow for fuel expansion. If gasoline is accidentally spilled, move machine away from area of spill. Avoid creating any source of ignition until gasoline vapors have disappeared. Do not overfill. Wipe off any spilled oil or fuel. Do not store, spill or use gasoline near an open flame.

### TO START ENGINE

**⚠CAUTION:** Keep tine control in "OFF" position when starting engine. When starting engine for the first time or if engine has run out of fuel, it will take extra pulls of the recoil starter to move fuel from the tank to the engine.

- Make sure spark plug wire is properly connected.
- Place throttle control in "FAST" position.
- Move choke control to full "CHOKE" position. Grasp recoil starter handle with one hand and grasp tiller handle with other hand. Pull rope out slowly until engine reaches start of compression cycle (rope will pull slightly harder at this point).
- Pull recoil starter handle quickly. Do not let starter handle snap back against starter. Repeat if necessary.
- If engine fires but does not start, move choke control to half choke position. Pull recoil starter handle until engine starts.
- When engine starts, slowly move choke control to "RUN" position as engine warms up.

**NOTE:** A warm engine requires less choking to start.

- Move throttle control to desired running position.
- Allow engine to warm up for a few minutes before engaging tines.

**NOTE:** If at a high altitude (3000 feet) or in cold temperatures (below 32°F), the carburetor fuel mixture may need to be adjusted for best engine performance. See "TO ADJUST CARBURETOR" in the Service and Adjustments section of this manual.

**NOTE:** If engine does not start, see troubleshooting points.

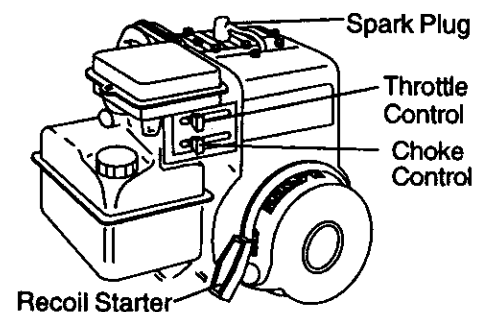

## BREAKING IN YOUR TILLER

Break-in your belt(s), pulleys and tine control before you actually begin tilling.

- Start engine, tip tines off ground by pressing handles down and engage tine control to start tine rotation. Allow tines to rotate for five minutes.
- Check tine operation and adjust if necessary. See "TINE OPERATION CHECK" in the Service and Adjustments section of this manual.

## TILLING HINTS

**CAUTION:** Until you are accustomed to handling your tiller, start actual field use with throttle in slow position.

To help tiller move forward, lift up the handles slightly (thus lifting depth stake out of ground). To slow down the tiller, press down on handles.

If you are straining or tiller is shaking, the wheels and depth stake are not set properly in the soil being tilled. The proper setting of the wheels and depth stake is through trial and error and depends upon the soil condition. (The harder or wetter the ground, the slower the engine and tine speed needed. Under these poor conditions, at fast speed the tiller will run and jump over the ground).

A properly adjusted tiller will dig with little effort from the operator.

- Tilling is digging into, turning over, and breaking up packed soil before planting. Loose, unpacked soil helps root growth. Best tilling depth is 4"-6". A tiller will also clear the soil of unwanted vegetation. The decomposition of this vegetable matter enriches the soil. Depending on the climate (rainfall and wind), it may be advisable to till the soil at the end of the growing season to further condition the soil.
- Soil conditions are important for proper tilling. Tines will not readily penetrate dry, hard soil which may contribute to excessive bounce and difficult handling of your tiller. Hard soil should be moistened before tilling; however, extremely wet soil will "ball-up" or clump during tilling. Wait until the soil is less wet in order to achieve the best results. When tilling in the fall, remove vines and long grass to prevent them from wrapping around the tine shaft and slowing your tilling operation.

- You will find tilling much easier if you leave a row untilled between passes. Then go back between tilled rows. There are two reasons for doing this. First, wide turns are much easier to negotiate than about-faces. Second, the tiller won't be pulling itself, and you, toward the row next to it.
- Set depth stake and wheel height for shallow tilling when working extremely hard soil or sod. Then work across the first cuts at normal depth.

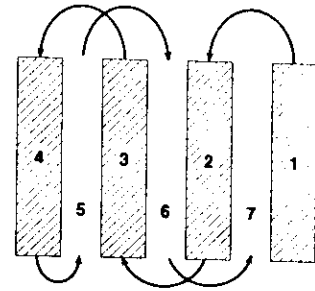

## CULTIVATING

Cultivating is destroying the weeds between rows to prevent them from robbing nourishment and moisture from the plants. At the same time, breaking up the upper layer of soil crust will help retain moisture in the soil. Best digging depth is 1"-3".

- You will probably not need to use the depth stake. Begin by tipping the depth stake forward until it is held by the stake spring.
- Cultivate up and down the rows at a speed which will allow tines to uproot weeds and leave the ground in rough condition, promoting no further growth of weeds and grass.

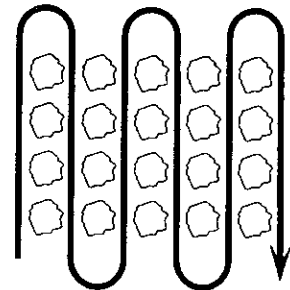

# MAINTENANCE

<b>MAINTENANCE SCHEDULE</b>	BEFORE EACH USE	EVERY 5 HOURS	EVERY 25 HOURS	EVERY 50 HOURS	SERVICE DATES															
FILL IN DATES AS YOU COMPLETE REGULAR SERVICE																				
Check Engine Oil Level	✓	✓																		
Change Engine Oil				✓ <sub>1,2</sub>																
Oil Pivot Points		✓																		
Inspect Spark Arrester / Muffler				✓																
Inspect Air Screen	✓																			
Clean or Replace Air Cleaner Cartridge				✓ <sub>2</sub>																
Clean Engine Cylinder Fins				✓																
Replace Spark Plug				✓																

1 - Change more often when operating under a heavy load or in high ambient temperatures.  
 2 - Service more often when operating in dirty or dusty conditions.

## GENERAL RECOMMENDATIONS

The warranty on this tiller does not cover items that have been subjected to operator abuse or negligence. To receive full value from the warranty, the operator must maintain tiller as instructed in this manual.

Some adjustments will need to be made periodically to properly maintain your tiller. All adjustments in the Service and Adjustments section of this manual should be checked at least once each season.

- Once a year you should replace the spark plug, clean or replace air filter, and check tines and belts for wear. A new spark plug and clean air filter assure proper air-fuel mixture and help your engine run better and last longer.

### BEFORE EACH USE

- Check engine oil level.
- Check tine operation.
- Check for loose fasteners.

### LUBRICATION

Keep unit well lubricated (See "LUBRICATION CHART")

## LUBRICATION

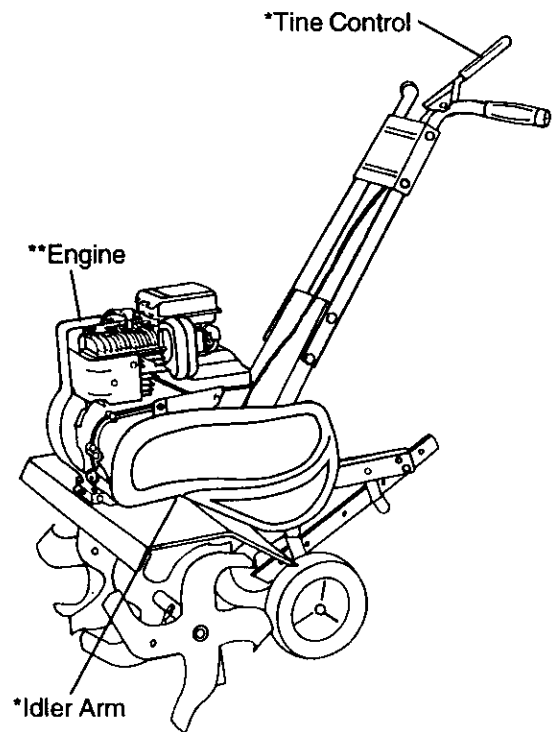

\* SAE30 or 10W-30 Motor Oil  
 \*\* Refer to Maintenance "ENGINE" Section

**CAUTION:** Disconnect spark plug wire before performing any maintenance (except carburetor adjustment) to prevent accidental starting of engine. Prevent fires! Keep the engine free of grass, leaves, spilled oil, or fuel. Remove fuel from tank before tipping unit for maintenance. Clean muffler area of all grass, dirt, and debris. Do not touch hot muffler or cylinder fins as contact may cause burns.

## ENGINE LUBRICATION

Use only high quality detergent oil rated with API service classification SF, SG or SH. Select the oil's SAE viscosity grade according to your expected temperature.

SAE VISCOSITY GRADES	
← 5W-30	SAE 30 →
°F -20°	100°
°C -30°	40°
TEMPERATURE RANGE ANTICIPATED BEFORE NEXT OIL CHANGE	

**NOTE:** Although multi-viscosity oils (5W-30, 10W-30, etc.) improve starting in cold weather, these multi-viscosity oils will result in increased oil consumption when used above 32°F (0°C). Check your engine oil level more frequently to avoid possible engine damage from running low on oil.

Change the oil after every 50 hours of operation or at least once a year if the tiller is not used for 50 hours in one year. Check the crankcase oil level before starting the engine and after each five (5) hours of continuous use. Add SAE 30 motor oil or equivalent. Tighten oil filler plug securely each time you check the oil level.

### TO CHANGE ENGINE OIL

Determine temperature range expected before oil change. All oil must meet API service classification SF, SG or SH.

- Be sure tiller is on level surface.
- Oil will drain more freely when warm.
- Catch oil in a suitable container.
- Remove drain plug.
- Tip tiller forward to drain oil.
- After oil has drained completely, replace oil drain plug and tighten securely.
- Remove oil filler plug. Be careful not to allow dirt to enter the engine.
- Refill engine with oil. See "CHECK ENGINE OIL LEVEL" in the Operation section of this manual.

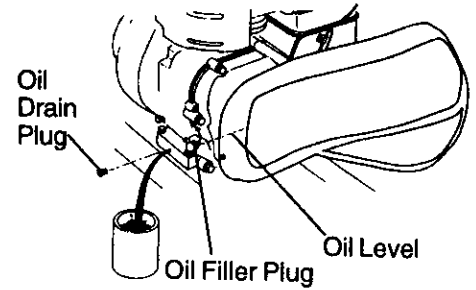

## AIR CLEANER

Service air cleaner cartridge every twenty-five hours, more often if engine is used in very dusty conditions.

- Loosen air cleaner screws, one on each side of cover.
- Remove air cleaner cover.
- Carefully remove air cleaner cartridge. Be careful. Do not allow dirt or debris to fall into carburetor.
- Clean by tapping gently on a flat surface.
- If very dirty or damaged, replace cartridge.
- Clean and replace cover. Tighten screws securely.

**CAUTION:** Petroleum solvents, such as kerosene, are not to be used to clean cartridge. They may cause deterioration of the cartridge. Do not oil cartridge. Do not use pressurized air to clean or dry cartridge.

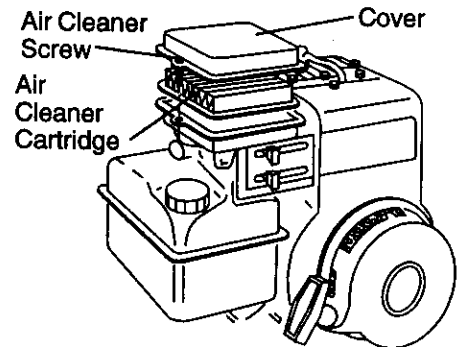

## COOLING SYSTEM

Your engine is air cooled. For proper engine performance and long life keep your engine clean.

- Clean air screen frequently using a stiff-bristled brush.
- Remove blower housing and clean as necessary.
- Keep cylinder fins free of dirt and chaff.

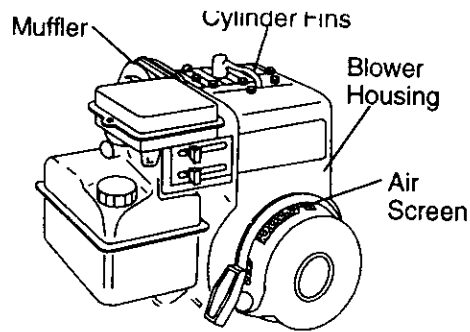

### MUFFLER

Do not operate tiller without muffler. Do not tamper with exhaust system. Damaged mufflers or spark arresters could create a fire hazard. Inspect periodically and replace if necessary. If your engine is equipped with a spark arrester screen assembly, remove every 50 hours for cleaning and inspection. Replace if damaged.

### SPARK PLUG

Replace spark plugs at the beginning of each tilling season or after every 50 hours of use, whichever comes first. Spark plug type and gap setting are shown in "PRODUCT SPECIFICATIONS".

### TRANSMISSION

Your transmission is sealed and will not require lubrication unless serviced.

### CLEANING

- Clean engine, wheels, finish, etc. of all foreign matter.
- Keep finished surfaces and wheels free of all gasoline, oil, etc.
- Protect painted surfaces with automotive type wax.

We do not recommend using a garden hose to clean your unit unless the muffler, air filter and carburetor are covered to keep water out. Water in engine can result in a shortened engine life.

## SERVICE AND ADJUSTMENTS

**CAUTION:** Disconnect spark plug wire from spark plug and place wire where it cannot come into contact with plug.

### TILLER

#### TO ADJUST HANDLE HEIGHT

Factory assembly has provided lowest handle height. Select handle height best suited for your tilling conditions. Handle height will be different when tiller digs into soil.

- If a higher handle height is desired, loosen the four nuts securing handle panel to engine brackets.
- Slide handle panel to desired location.
- Tighten the four nuts securely.

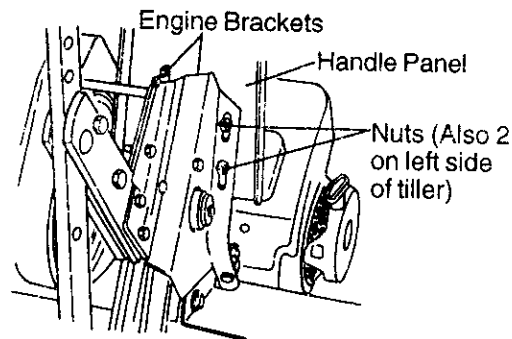

### TINE ARRANGEMENT

Your outer tines can be assembled in several different ways to suit your tilling or cultivating needs.

**CAUTION:** Tines are sharp. Wear gloves or other protection when handling tines.

#### NORMAL TILLING - 17" PATH

- Assemble holes "A" in tine hubs to holes "B" in tine shaft.

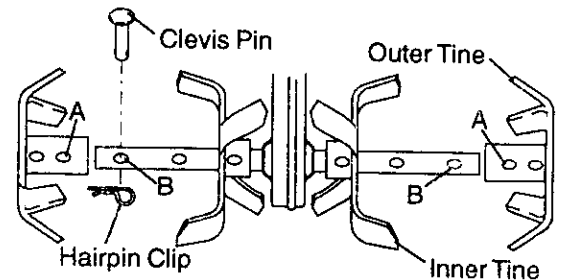

#### MID-WIDTH TILLING - 15" PATH

- Assemble holes "A" in tine hubs to holes "C" in tine shaft.

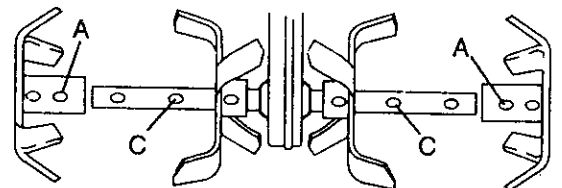

### NARROW TILLING/CULTIVATING - 10-1/4" PATH

- Remove outer tines.

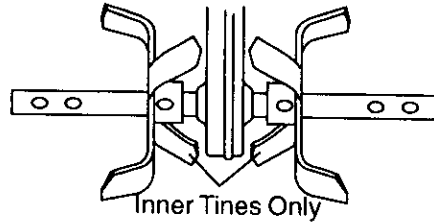

### NARROW CULTIVATING - 12-1/2" PATH

- Remove inner tines.
- Assemble holes "A" in tine hubs to holes "C" in tine shaft.

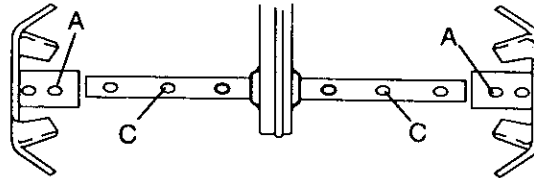

### EDGING - 9-5/8" PATH

- Remove inner tines.
- Assemble holes "A" in tine hubs to holes "D" in tine shaft.

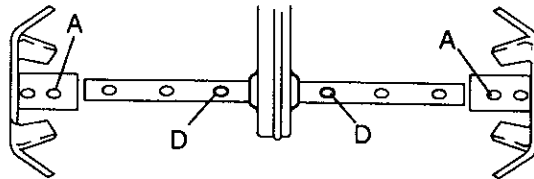

**NOTE:** When reassembling outer tines, be sure right tine assembly (marked "R") and left tine assembly (marked "L") are mounted to correct side of tine shaft.

### TINE OPERATION CHECK

Be sure tines do not rotate when engine is running and tine control is in the "OFF" position.

**CAUTION:** Disconnect spark plug wire from spark plug to prevent starting while checking tine operation.

### FINAL CHECK "OFF" POSITION

- With tine control "OFF" (up), push down on handle to raise tines off the ground.
- Slowly pull recoil starter handle while observing tines. Tines should not rotate.
- If tines rotate, place loop of idler spring in a lower link of chain and retest.

### FINAL CHECK "ON" POSITION

- With tine control "ON" (held down to handle) push down on handle to raise tines off the ground.

- Slowly pull recoil starter handle while observing tines. Tines should rotate forward.
- If tines do not rotate, place loop of idler spring in a higher link of chain and retest.

**NOTE:** If "ON" position check required adjustment, recheck "OFF" position adjustment to insure tines do not rotate when control is "OFF" (up).

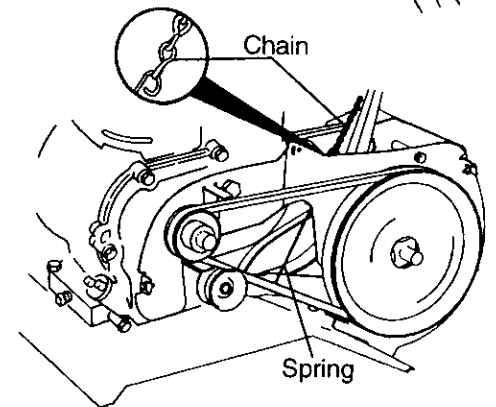
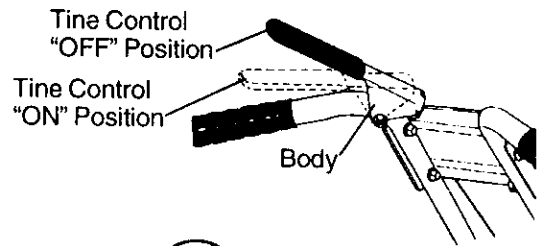

### TO REMOVE BELT GUARD

- Remove cap nut and washer from side of belt guard.
- Pull belt guard out and away from unit.
- Replace belt guard by reversing above procedure. Be sure slot in bottom of belt guard is under head of tine shield bolt and all nuts are tightened securely.

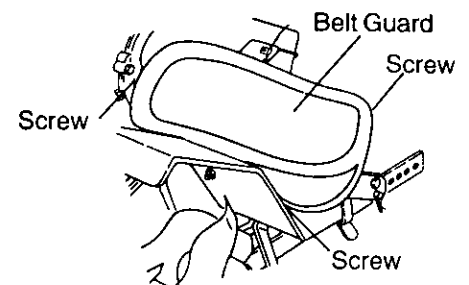

## TO REPLACE V-BELT

Replace V-belt if it has stretched considerably or if it has cracks or frayed edges. Belt guard must be removed to service belt. See "TO REMOVE BELT GUARD" in this section of manual.

### BELT REMOVAL

- Remove V-belt from transmission pulley first and then from engine pulley.

### BELT REPLACEMENT

- Install new V-belt to engine pulley first then to transmission pulley. Be sure belt is positioned on inside groove of both pulleys, inside all belt guides and rests on idler pulley.

### CHECK TINE OPERATION

- See "TINE OPERATION CHECK" in this section of manual.

### REPLACE BELT GUARD

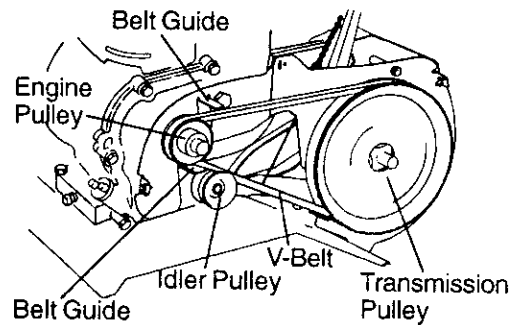

## ENGINE

Maintenance, repair, or replacement of the emission control devices and systems, which are being done at the customers expense, may be performed by any non-road engine repair establishment or individual. Warranty repairs must be performed by an authorized engine manufacturer's service outlet.

### TO ADJUST CARBURETOR

The carburetor has a high speed fixed jet and has been preset at the factory and adjustment should not be necessary. However, minor adjustments may be required to compensate for differences in fuel, temperature, altitude or load. If the carburetor does need adjustment, proceed as follows.

## FINAL SETTING

- Start engine and allow to warm for five minutes.
- With throttle control in "SLOW" position.

### IDLE RPM ADJUSTMENT

- To adjust idle RPM, rotate throttle linkage counterclockwise and hold against stop while adjusting idle speed adjusting screw to obtain 1750 RPM. Release throttle linkage.

High speed stop is factory adjusted. Do not adjust or damage may result.

**IMPORTANT:** Never tamper with the engine governor, which is factory set for proper engine speed. overspeeding the engine above the factory high speed setting can be dangerous. If you think the engine-governed high speed needs adjusting, contact your nearest authorized service center/department, which has the proper equipment and experience to make any necessary adjustments.

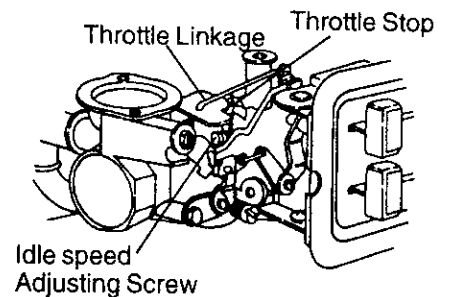

# STORAGE

Immediately prepare your tiller for storage at the end of the season or if the unit will not be used for 30 days or more.

**CAUTION:** Never store the tiller with gasoline in the tank inside a building where fumes may reach an open flame or spark. Allow the engine to cool before storing in any enclosure.

## TILLER

- Clean entire tiller (See "CLEANING" in the Maintenance section of this manual).
- Inspect and replace belts, if necessary (See belt replacement instructions in the Service and Adjustments section of this manual).
- Lubricate as shown in the Maintenance section of this manual.
- Be sure that all nuts, bolts and screws are securely fastened. Inspect moving parts for damage, breakage and wear. Replace if necessary.
- Touch up all rusted or chipped paint surfaces; sand lightly before painting.

## ENGINE

### FUEL SYSTEM

**IMPORTANT:** It is important to prevent gum deposits from forming in essential fuel system parts such as the carburetor, fuel filter, fuel hose, or tank during storage. also, experience indicates that alcohol blended fuels (called gasohol or using ethanol or methanol) can attract moisture which leads to separation and formation of acids during storage. Acidic gas can damage the fuel system of an engine while in storage.

- Drain the fuel tank.
- Start the engine and let it run until the fuel lines and carburetor are empty.
- Never use engine or carburetor cleaner products in the fuel tank or permanent damage may occur.
- Use fresh fuel next season.

**NOTE:** Fuel stabilizer is an acceptable alternative in minimizing the formation of fuel gum deposits during storage. Add stabilizer to gasoline in fuel tank or storage container. Always follow the mix ratio found on stabilizer container. Run engine at least 10 minutes after adding stabilizer to allow the stabilizer to reach the carburetor. Do not drain the gas tank and carburetor if using fuel stabilizer.

### ENGINE OIL

Drain oil (with engine warm) and replace with clean oil. (See "ENGINE" in the Maintenance section of this manual).

### CYLINDER(S)

- Remove spark plug.
- Pour 1 ounce (29 ml) of oil through spark plug hole into cylinder.
- Pull starter handle slowly several times to distribute oil.
- Replace with new spark plug.

### OTHER

- Do not store gasoline from one season to another.
- Replace your gasoline can if your can starts to rust. Rust and/or dirt in your gasoline will cause problems.
- If possible, store your unit indoors and cover it to give protection from dust and dirt.
- Cover your unit with a suitable protective cover that does not retain moisture. Do not use plastic. Plastic cannot breathe which allows condensation to form and will cause your unit to rust.

**IMPORTANT:** Never cover tiller while engine and exhaust areas are still warm.



# TROUBLESHOOTING

PROBLEM	CAUSE	CORRECTION
<b>Will not start</b>	<ol style="list-style-type: none"> <li>1. Out of fuel.</li> <li>2. Engine not "CHOKED" properly.</li> <li>3. Engine flooded.</li> <li>4. Dirty air cleaner.</li> <li>5. Water in fuel.</li> <li>6. Clogged fuel tank.</li> <li>7. Loose spark plug wire.</li> <li>8. Bad spark plug or improper gap.</li> <li>9. Carburetor out of adjustment.</li> </ol>	<ol style="list-style-type: none"> <li>1. Fill fuel tank.</li> <li>2. See "TO START ENGINE" in the Operation section.</li> <li>3. Wait several minutes before attempting to start.</li> <li>4. Clean or replace air cleaner cartridge.</li> <li>5. Drain fuel tank and carburetor, and refill tank with fresh gasoline.</li> <li>6. Remove fuel tank and clean.</li> <li>7. Make sure spark plug wire is seated properly on plug.</li> <li>8. Replace spark plug or adjust gap.</li> <li>9. Make necessary adjustments.</li> </ol>
<b>Hard to start</b>	<ol style="list-style-type: none"> <li>1. Throttle control not set properly.</li> <li>2. Dirty air cleaner.</li> <li>3. Bad spark plug or improper gap.</li> <li>4. Stale or dirty fuel.</li> <li>5. Loose spark plug wire.</li> <li>6. Carburetor out of adjustment.</li> </ol>	<ol style="list-style-type: none"> <li>1. Place throttle control in "FAST" position.</li> <li>2. Clean or replace air cleaner cartridge.</li> <li>3. Replace spark plug or adjust gap.</li> <li>4. Drain fuel tank and refill with fresh gasoline.</li> <li>5. Make sure spark plug wire is seated properly on plug.</li> <li>6. Make necessary adjustments.</li> </ol>
<b>Loss of power</b>	<ol style="list-style-type: none"> <li>1. Engine is overloaded.</li> <li>2. Dirty air cleaner.</li> <li>3. Low oil level/dirty oil.</li> <li>4. Faulty spark plug.</li> <li>5. Oil in fuel.</li> <li>6. Stale or dirty fuel.</li> <li>7. Water in fuel.</li> <li>8. Clogged fuel tank.</li> <li>9. Spark plug wire loose.</li> <li>10. Dirty engine air screen.</li> <li>11. Dirty/clogged muffler.</li> <li>12. Carburetor out of adjustment.</li> <li>13. Poor compression.</li> </ol>	<ol style="list-style-type: none"> <li>1. Set depth stake and wheels for shallower tilling.</li> <li>2. Clean or replace air cleaner cartridge.</li> <li>3. Check oil level/change oil.</li> <li>4. Clean and regap or change spark plug.</li> <li>5. Drain and clean fuel tank and refill, and clean carburetor.</li> <li>6. Drain fuel tank and refill with fresh gasoline.</li> <li>7. Drain fuel tank and carburetor, and refill tank with fresh gasoline.</li> <li>8. Remove fuel tank and clean.</li> <li>9. Connect and tighten spark plug wire.</li> <li>10. Clean engine air screen.</li> <li>11. Clean/replace muffler.</li> <li>12. Make necessary adjustments.</li> <li>13. Contact an authorized Sears Service Center/Department.</li> </ol>

<b>PROBLEM</b>	<b>CAUSE</b>	<b>CORRECTION</b>
<b>Engine overheats</b>	<ol style="list-style-type: none"> <li>1. Low oil level/dirty oil.</li> <li>2. Dirty engine air screen.</li> <li>3. Dirty engine.</li> <li>4. Partially plugged muffler.</li> <li>5. Improper carburetor adjustment.</li> </ol>	<ol style="list-style-type: none"> <li>1. Check oil level/change oil.</li> <li>2. Clean engine air screen.</li> <li>3. Clean cylinder fins, air screen, muffler area.</li> <li>4. Remove and clean muffler.</li> <li>5. Adjust carburetor to richer position.</li> </ol>
<b>Excessive bounce/difficult handling</b>	<ol style="list-style-type: none"> <li>1. Ground too dry and hard.</li> <li>2. Wheels and depth stake incorrectly adjusted.</li> </ol>	<ol style="list-style-type: none"> <li>1. Moisten ground or wait for more favorable soil conditions.</li> <li>2. Adjust wheels and depth stake.</li> </ol>
<b>Soil balls up or clumps</b>	<ol style="list-style-type: none"> <li>1. Ground too wet.</li> </ol>	<ol style="list-style-type: none"> <li>1. Wait for more favorable soil conditions.</li> </ol>
<b>Engine runs but tiller won't move</b>	<ol style="list-style-type: none"> <li>1. Tine control is not engaged.</li> <li>2. V-belt not correctly adjusted.</li> <li>3. V-belt is off pulley(s).</li> </ol>	<ol style="list-style-type: none"> <li>1. Engage tine control.</li> <li>2. Inspect/adjust V-belt.</li> <li>3. Inspect V-belt.</li> </ol>
<b>Engine runs but labors when tilling</b>	<ol style="list-style-type: none"> <li>1. Tilling too deep.</li> <li>2. Throttle control not setting.</li> <li>3. Carburetor out of adjustment.</li> </ol>	<ol style="list-style-type: none"> <li>1. Set depth stake for shallower tilling.</li> <li>2. Check throttle control properly adjusted.</li> <li>3. Make necessary adjustments.</li> </ol>

# REPAIR PARTS

TILLER - - MODEL NUMBER 917.292381

## HANDLE ASSEMBLY

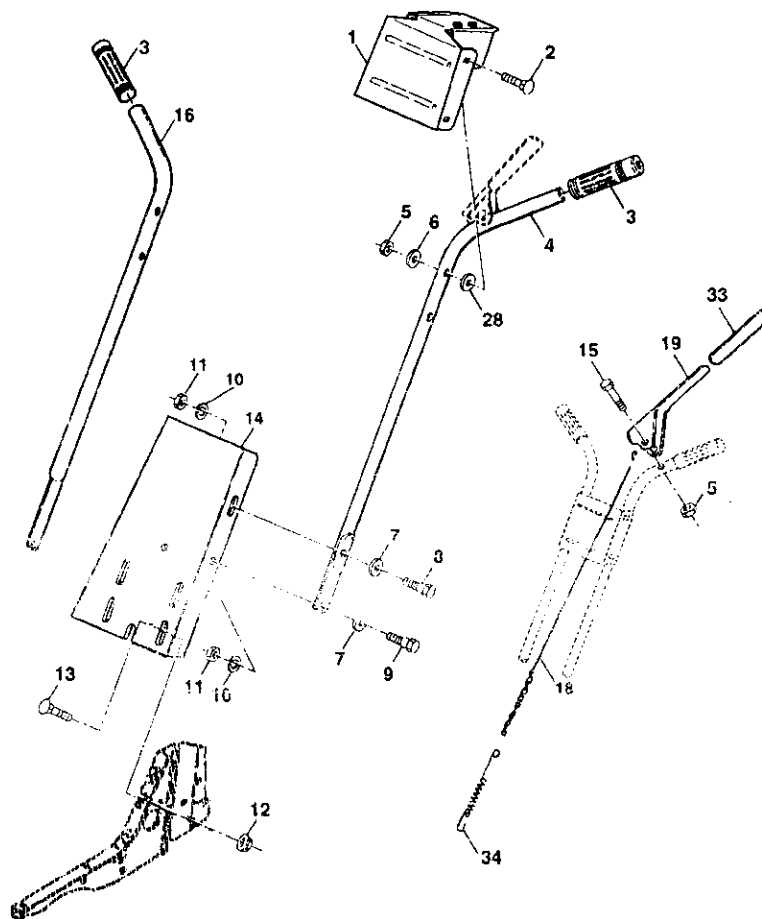

### KEY PART NO. NO.

1 137176X431  
2 72140512  
3 9266R  
4 151473  
5 73680500  
6 19111116  
7 19121414  
8 74760516  
9 74760512  
10 10040500  
11 73220500  
12 98000129

### DESCRIPTION

Bracket, Handle  
\*Bolt, Carriage  
5/16-18 UNC x 1-1/2  
Grip, Handle  
Handle, L.H.  
\*Locknut, Crown 5/16-18  
\*Washer 11/32 x 11/16 x 16 Ga.  
\*Washer 3/8 x 7/8 x 14 Ga.  
Bolt, Hex Hd 5/16-18 x 1  
Bolt, Hex Hd 5/16-18 x 3/4  
\*Washer, Lock 5/16  
\*Nut, Hex 5/16-18  
\*Nut, Flanged 5/16-18

### KEY PART NO. NO.

13 72140506  
14 9209R431  
15 74760524  
16 151474  
18 3067J  
19 164937  
28 19131312  
33 8206H  
34 3070J

### DESCRIPTION

\*Bolt, Carriage 5/16-18 x 3/4  
Gr. 5  
Panel, Handle  
\*Bolt, Hex 5/16-18 x 1-1/2  
Handle, R.H.  
Cable, Control, Tine  
Lever, Clutch 8.00  
Washer 13/32 x 13/16 x 12 Ga.  
Grip, Lever  
Spring, Extension

\*STANDARD HARDWARE—PURCHASE LOCALLY

NOTE: All component dimensions given in U.S. inches. 1 inch = 25.4 mm

**TILLER - - MODEL NUMBER 917.292381**  
**BELT GUARD AND PULLEY ASSEMBLY**

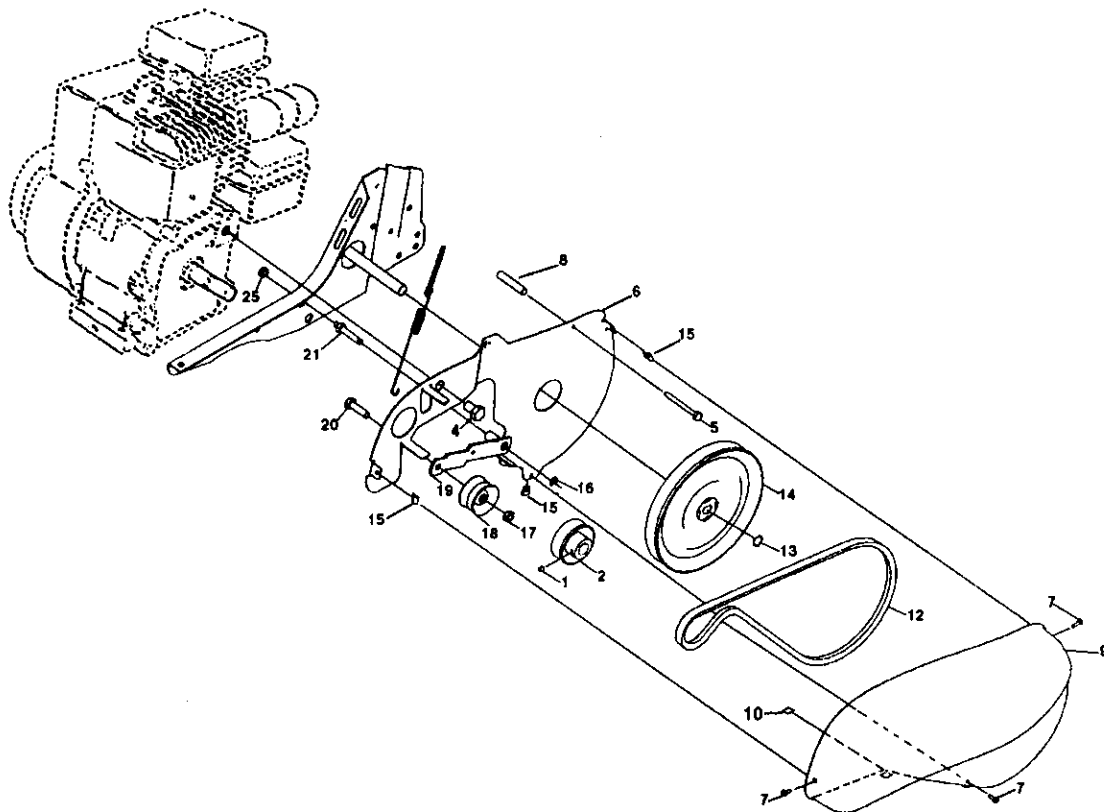

**KEY PART  
NO. NO.**

1	23230506
2	130812
4	74610812
5	17490440
6	165770
7	165503
8	9223R
9	165768X558
10	109227X
12	9180R
13	12000028
14	151223

**DESCRIPTION**

*Screw, Set, Forged Socket, Headless 5/16-18 x 3/8
Sheave, Engine
Bolt, Hex 1/2-20 x 3/4
Bolt, Thd Roller 1/4-20 x 2-1/2
Shield, Inner Guard Blt Ft
Screw Hex Wsh Hd #8-18 x 1/2
Spacer, Split
Guard, Belt
Pad, Idler
V-Belt
Ring, Retainer
Sheave, Transmission

**KEY PART  
NO. NO.**

15	165504
16	12000036
17	73350600
18	161806
19	162290
20	74760620
21	106968X
25	73350500

**DESCRIPTION**

Nut, J Clip
Ring, Klip
*Nut, Hex, Jam 3/8-16
Pulley, Idler
Idler Arm Assembly
*Bolt, Hex 3/8-16 x 1-1/4
Shaft, Idler Arm
*Nut, Hex, Jam 5/16-18

**\*STANDARD HARDWARE—PURCHASE LOCALLY**

**NOTE: All component dimensions given in U.S. inches. 1 inch = 25.4 mm**

**TILLER - - MODEL NUMBER 917.292381**  
**WHEEL AND DEPTH STAKE ASSEMBLY**

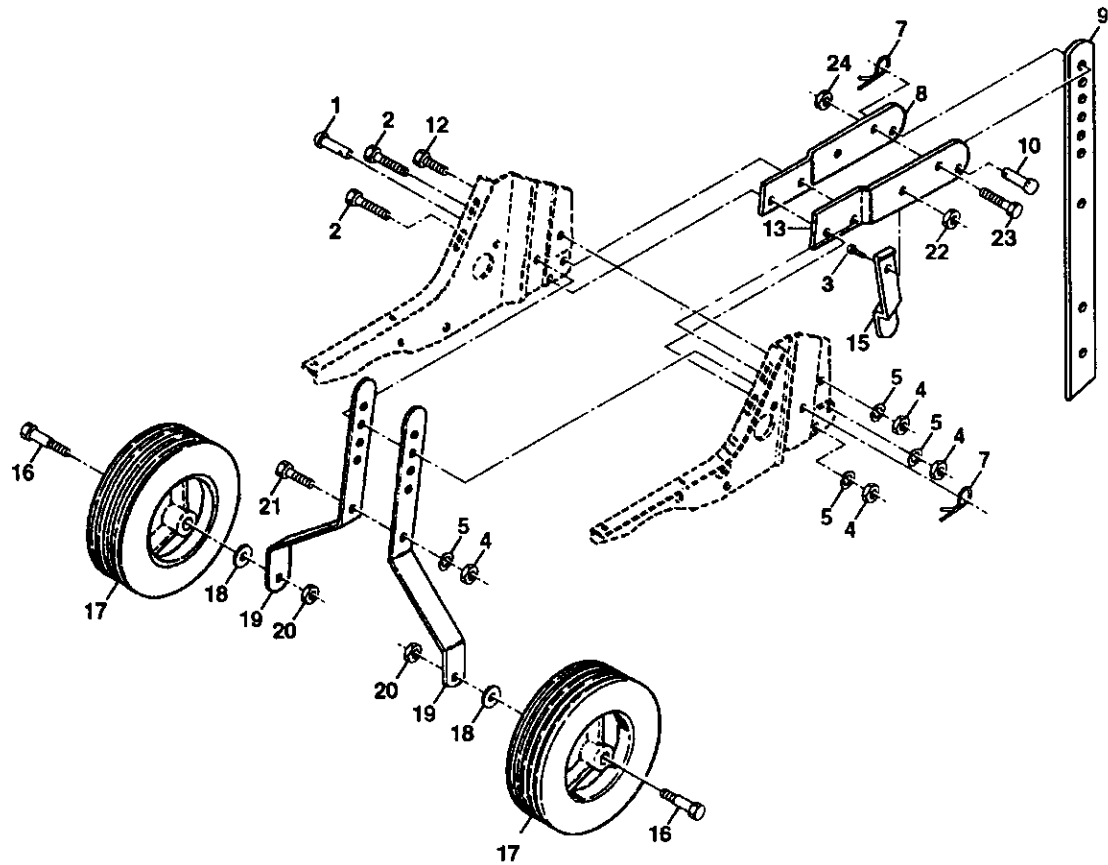

**KEY PART  
NO. NO.**

KEY PART NO.	NO.	DESCRIPTION
1	9194R	Pin Clevis
2	74760520	*Bolt, Hex 5/16-18 x 1-1/4
3	STD523107	Boit Hex Hd 5/16-18 UNC x 3/4
4	STD541031	*Nut, Hex 5/16-18
5	STD551131	*Washer, Lock 5/16
6	STD541437	Locknut, W/insert 3/8-16
7	4921H	Clip, Hairpin
8	318J	Support, Depth Stake, R.H.
9	9193R	Depth Stake
10	9551R	Pin, Clevis
11	74780628	Bolt, Fin, Hex 3/8-16 x 1-3/4
12	74760524	Bolt, Hex 5/16-18 X 1-1/2
13	317J	Support, Depth Stake, L.H.

**KEY PART  
NO. NO.**

KEY PART NO.	NO.	DESCRIPTION
15	5388J	Spring, Depth Stake
16	121117X	Bolt, Shoulder
17	9186R	Wheel
18	STD551037	*Washer 13/32 x 13/16 x 11 Ga
19	9190R	Bracket, Wheel
20	STD541437	*Nut, Crownlock 3/8-16
21	74760516	Bolt Hex 5/16-18 x 1
22	STD541431	Locknut, W/insert 5/16-18

\*STANDARD HARDWARE—PURCHASE LOCALLY

**NOTE:** All component dimensions given in U.S. inches. 1 inch = 25.4 mm

TILLER - - MODEL NUMBER 917.292381

TINE ASSEMBLY

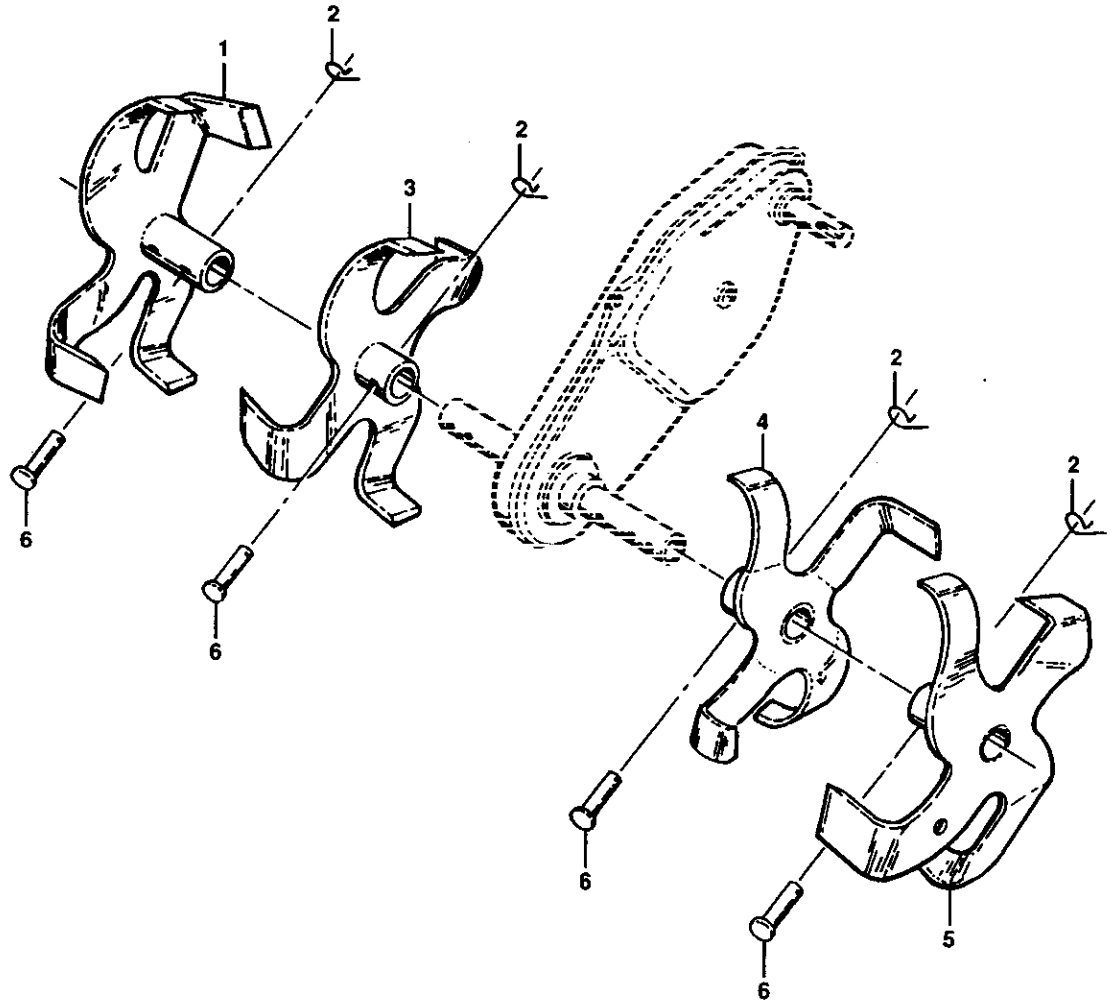

**KEY PART  
NO. NO.**

1 165774  
2 4921H  
3 165772

**DESCRIPTION**

Tine, Outer, R.H.  
Clip, Hairpin  
Tine, Inner, R.H.

**KEY PART  
NO. NO.**

4 165771  
5 165773  
6 9194R

**DESCRIPTION**

Tine, Inner, L.H.  
Tine, Outer, L.H.  
Pin, Clevis

# TILLER - - MODEL NUMBER 917.292381

## TRANSMISSION

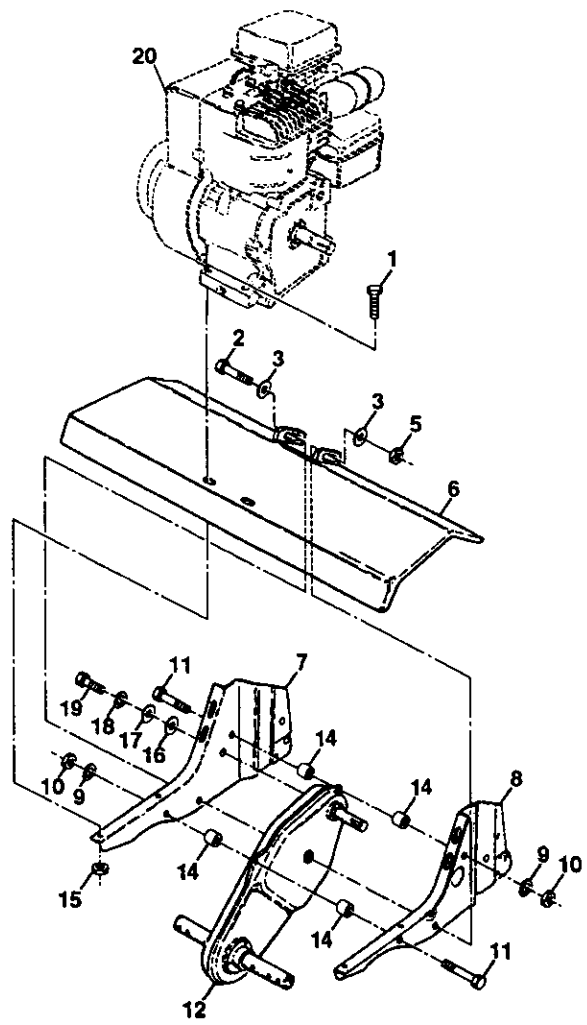

KEY PART NO.	NO.	DESCRIPTION
1	74760524	Bolt, Hex 5/16-18 x 1-1/2 Gr. 2
2	STD523732	Bolt, Fin, Hex 3/8-16 x 3-1/4
3	STD551037	Washer 13/32 x 13/16 x 11
5	STD541437	Locknut, w/washer 3/8-16
6	9056R558	Shield, Tine
7	165835	Bracket, Engine, R.H.
8	165834	Bracket, Engine, L.H.
9	STD551131	Washer, Lock 5/16
10	STD541031	Nut, Hex 5/16-18
11	74760544	Bolt, Hex Hd 5/16-18 x 2-3/4
12	151937	Transmission
14	9173R	Spacer, Split

KEY PART NO.	NO.	DESCRIPTION
15	STD541431	Nut, Keps 5/16-18
16	19091412	Washer 9/32 x 7/8 x 12 Ga.
17	19092016	Washer 9/32 x 1-1/4 x 16 Ga.
18	STD551125	Washer, Lock 1/4
19	74610412	Bolt, Hex 1/4-28 x 3/4 Gr. 5
20	-----	Engine, Briggs & Stratton Model No. 94202-0115-E1

\*STANDARD HARDWARE—PURCHASE LOCALLY

NOTE: All component dimensions given in U.S. inches. 1 inch = 25.4 mm

# TILLER - - MODEL NUMBER 917.292381

## DECALS

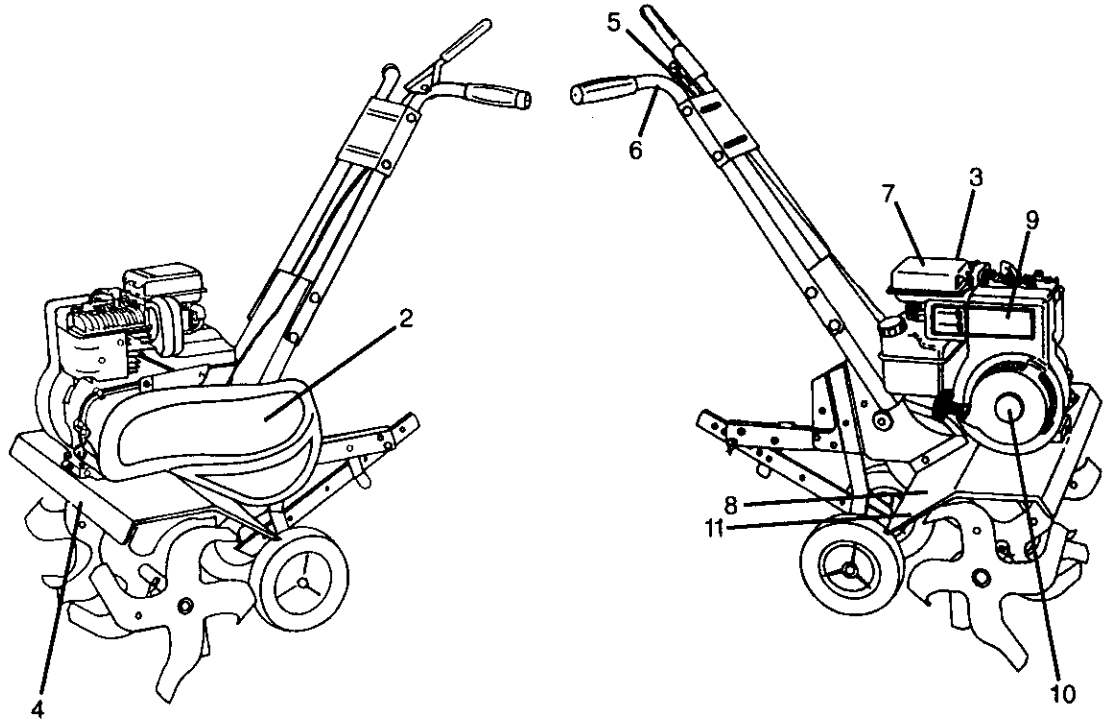

### KEY PART NO. NO.

2 166128  
 3 165327  
 4 166129  
 5 110594X  
 6 120431X  
 7 110719X  
 8 120075X  
 9 171803  
 10 171920  
 11 162215  
 12 163165  
 -- 172054

### DESCRIPTION

Decal, Logo  
 Decal, Engine Ref.  
 Decal, Belt Guard Tine Shield  
 Decal, Control Pnl Inst.  
 Decal, Hand Placement  
 Decal, Oper/Lubrication  
 Decal, Warning, Rotating Tines  
 Decal, Engine  
 Decal, HP  
 Decal, Tine Shield Wmg Dom  
 Decal, Control Panel  
 Manual, Owner's (Eng/Span)



**TILLER - - MODEL NUMBER 917.292381**  
**BRIGGS & STRATTON ENGINE -- MODEL NUMBER 94202, TYPE NO.0115-E1**

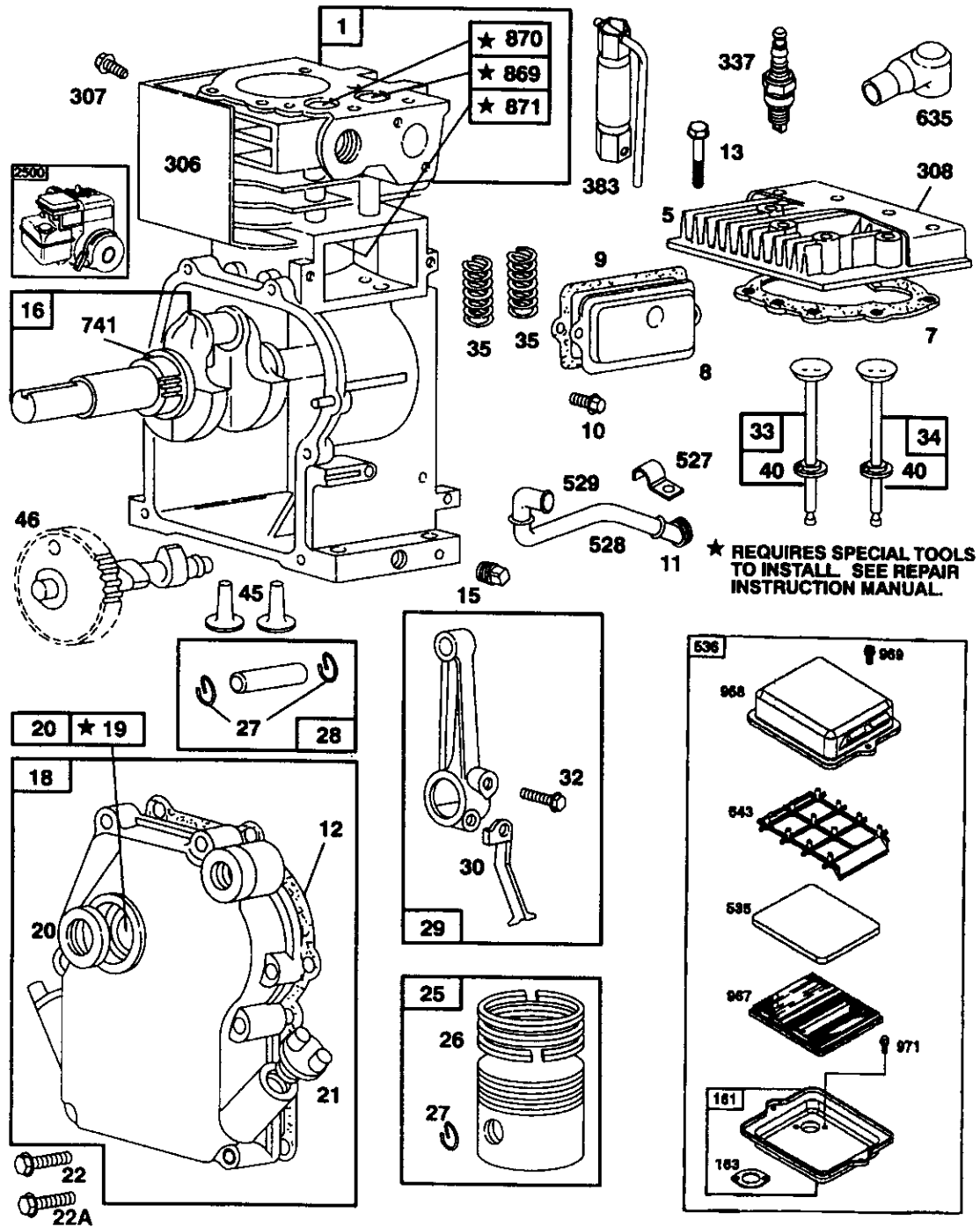

TILLER - - MODEL NUMBER 917.292381  
BRIGGS & STRATTON ENGINE - MODEL NUMBER 94202, TYPE NO.0115-E1

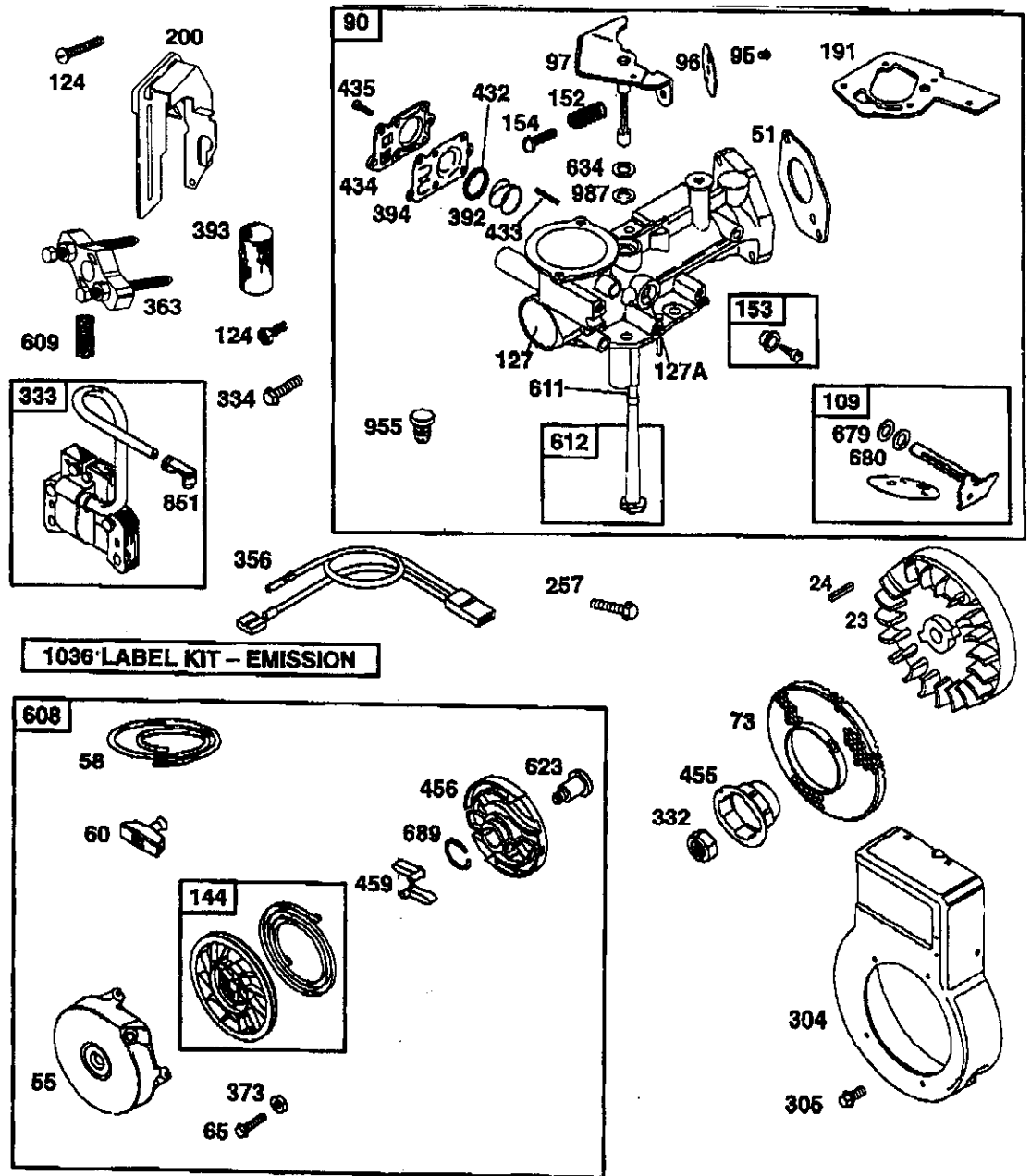

**TILLER - - MODEL NUMBER 917.292381  
BRIGGS & STRATTON ENGINE -- MODEL NUMBER 94202, TYPE NO.0115-E1**

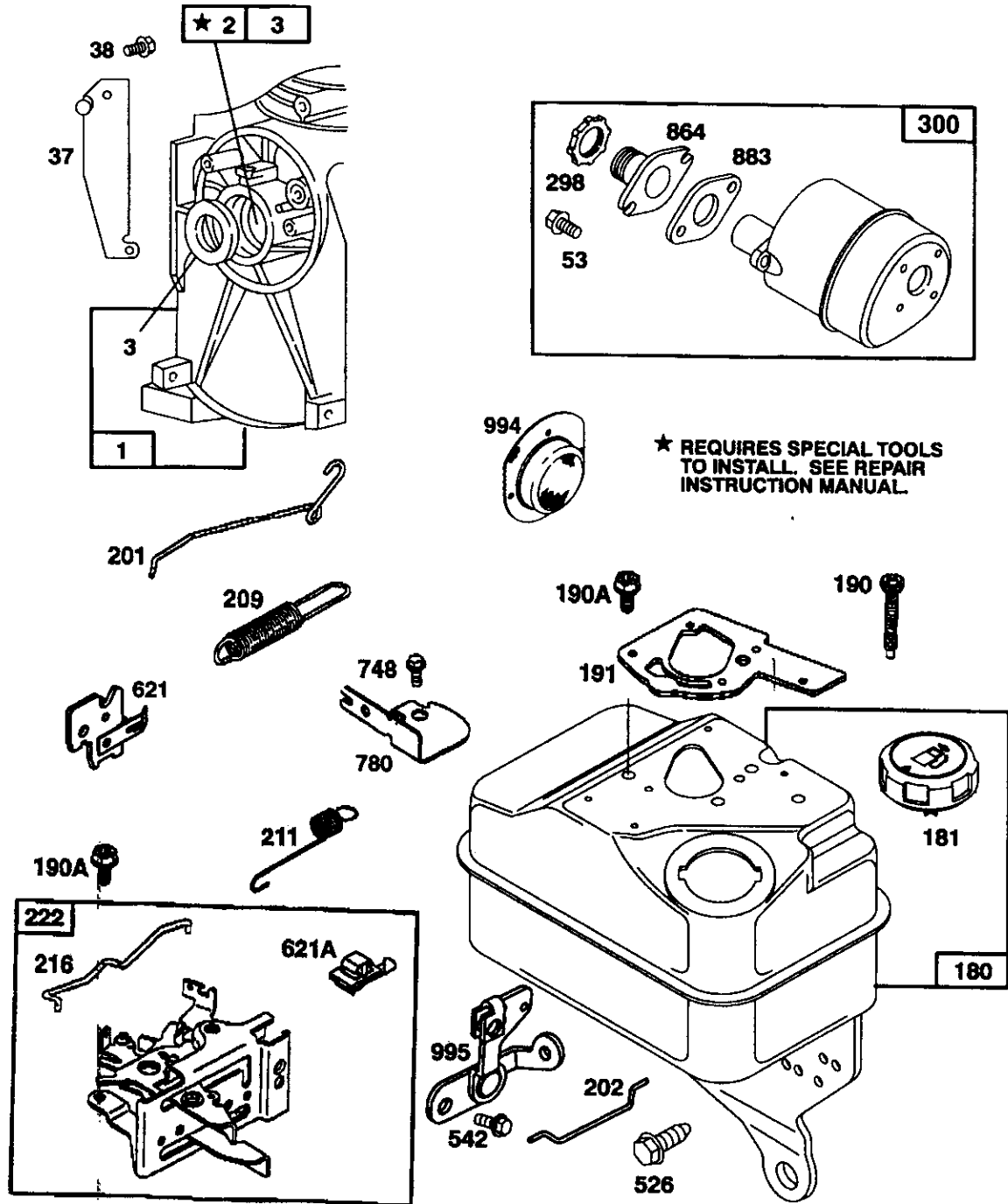

TILLER - - MODEL NUMBER 917.292381  
BRIGGS & STRATTON ENGINE -- MODEL NUMBER 94202, TYPE NO.0115-E1

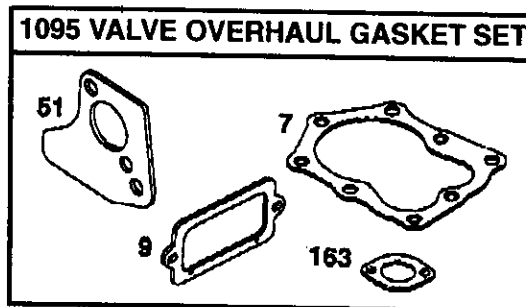
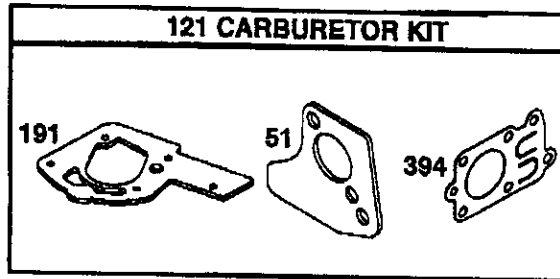
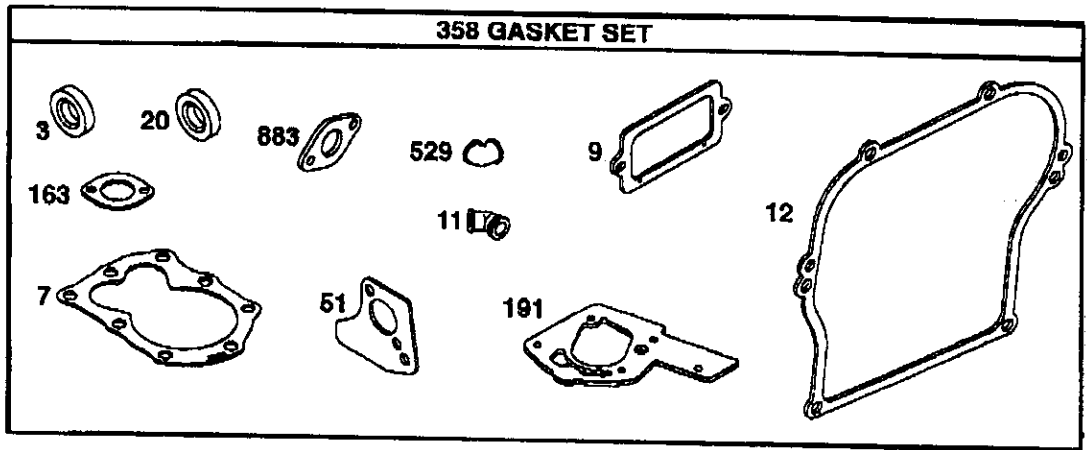

**TILLER - - MODEL NUMBER 917.292381**  
**BRIGGS & STRATTON ENGINE - - MODEL NUMBER 94202, TYPE NO.0115-E1**

KEY NO.	PART NO.	DESCRIPTION	KEY NO.	PART NO.	DESCRIPTION
1	494549	Cylinder Assembly	35	260552	Spring, Valve
2	293708	Bushing, Cylinde (Special Tools Required For Installation)	37	224557	Guard, Flywheel
3	299819	* Seal, Oil	38	94736	Screw, Hex
5	214277	Head, Cylinder	40	93312	Retainer, Valve Spring
7	272694	Ø* Gasket, Cylinder Head	45	230173	Tappet, Valve
8	495774	Breather, Valve Chamber	46	493747	Gear, Cam
9	27549	Ø* Gasket, Valve Cover	51	273113	Ø** Gasket, Carb, Mounting
10	94621	Screw, Sems, Valve Cover Mount.	53	94523	Screw, Exhaust
11	66578	* Grommet, Breather Tube	55	499441	Housing, Rewind, Starter
12	270833	* Gasket, Crankcase, Standard .015"	58	281464	Rope, Starter
	270895	* Gasket, Crankcase .005"	60	393152	Grip, Starter Rope
	270896	* Gasket, Crankcase .009"	65	94904	Screw, Starter, Housing
13	94960	Screw, Cylinder Head	73	225381	Screen, Rotating
15	94387	Plug, Oil Drain (Opposite Carb Side)	90	499491	Carburetor Assembly
16	495211	Crankshaft	95	93499	Screw, Slotted
	499047	Key, Timing Gear Retaining	96	223793	Valve, Throttle
18	394820	Cover Assembly, Crankcase	97	495313	Shaft and Lever, Throttle
19	293708	Bushing, Crankcase	109	497230	Choke, Shaft Kit
20	299819	* Seal, Oil	121	495606	Carburetor, Overhaul Kit
21	281658	Plug, Oil Filler	124	94616	Screw, Torx®
22	94607	Screw, Hex	127	220352	Plug, Welch
22A	94862	Screw, Hex, (Used In Pos. No. 1)	127A	223789	Plug, Welch
23	496278	Flywheel	144	499901	Pulley/Spring Assy.
24	222698	Key, Flywheel	152	260575	Spring Throttle Adjustment
25	498668	Piston Assembly, Standard	153	490501	Collar, Bell, Crank
	498669	Piston Assembly .010" Oversize	154	93527	Screw, Slotted
	498670	Piston Assembly .020" Oversize	161	492797	Base, Air Cleaner
	498671	Piston Assembly .030" Oversize	163	271935	Ø* Gasket, Air Cleaner
26	498680	Ring Set, Piston, Standard	180	495377	Tank, Fuel
	498681	Ring Set, Piston .010" Oversize	181	494559	Cap, Fuel Tank
	498682	Ring Set, Piston .020" Oversize	190	94919	Screw, Torx®
	498683	Ring Set, Piston .030" Oversize	190A	94924	Screw, Torx®
27	26026	Lock, Piston Pin	191	272489	Gasket, Fuel Tank
28	298909	Pin Assembly, Piston, Standard			* Indicates Parts Included in Gasket Set (494550)
	298908	Pin Assembly, Piston .005" Over			** Indicates Parts Included in Carburetor Overhaul Kit (495606)
29	294367	Rod Assembly, Connecting			Ø Indicates Parts Included in Valve Overhaul Gasket Set (292638)
	296079	Rod Assembly, Connecting, .020" Undersize Crankpin Bore			<b>NOTE:</b> All component dimensions given in U.S. inches 1 inch = 25.4 mm
30	220670	Dipper, Connecting Rod			
32	94699	Screw, Connecting Rod			
33	296676	Valve, Exhaust (Includes Retainer Number 93312)			
34	296677	Valve, Intake			

**TILLER - - MODEL NUMBER 917.292381**  
**BRIGGS & STRATTON ENGINE – MODEL NUMBER 94202, TYPE NO.0115-E1**

KEY NO.	PART NO.	DESCRIPTION	KEY NO.	PART NO.	DESCRIPTION
200	495213	Blade, Governor	621A	396847	Switch, Stop
201	263174	Link, Governor	623	94943	Screw, Shoulder
202	262470	Link, Throttle	634	271853	Washer, Throttle Shaft, Foam
209	260041	Spring, Governor	635	66538	Elbow, Spark Plug
211	263030	Spring, Gov. Idle	643	280737	Spacer, Air Cleaner
216	263188	Link, Choke	679	270382	Washer, Choke Shaft, Foam
222	499533	Bracket, Control	680	221839	Washer, Choke Shaft
257	93543	Screw, Hex Head	689	260575	Spring, Friction
298	220859	Locknut, Muffler	741	261533	Gear, Timing
300	493288	Muffler, Exhaust	748	99669	Screw, Hex.
304	499522	Housing, Blower	780	225029	Anchor, Spring
305	94786	Screw, Sems	851	493880	Terminal, Ignition Cable
306	224555	Shield, Cylinder	864	492232	Adapter Assembly, Muffler
307	93758	Screw, Sems, Cylinder Shield Mnt.	869	211172	Seat, Intake Valve
308	224556	Cover, Cylinder Head	870	211291	Seat, Exhaust Valve
332	94877	Nut, Flywheel	871	231348	Guide, Exhaust Valve
333	496914	Armature, Magneto		63709	Guide, Intake Valve (See Repair Manual)
334	94731	Screw, Armature Mounting	883	272203	Gasket, Muffler
337	802592	Plug, Spark	955	281227	Plug
356	497298	Wire, Ground	967	491588	Filter, Air
358	495605	Gasket Set	968	495872	Cover, Air Cleaner
363	19203	Puller, Flywheel	969	490073	Screw, Slotted Hex, (Incl. Grommet)
373	94908	Nut, Hex	971	94902	Screw, Hex
383	89838	Wrench, Spark Plug	987	398970	Seal, Throttle Shaft
392	262328	Spring, Fuel Pump	994	398067	Spark Arrestor
393	225058	Screw, Carburetor	995	497195	Control, Throttle
394	272538	** Diaphragm	1036	499329	Label Kit, Emission
432	221377	Cap, Spring	1095	99669	Gasket Set, Valve Overhaul
433	93265	Pin, Diaphragm	2500	94202-0115	Replacement Engine
434	213963	Cover, Diaphragm	—	495914	Replacement Shortblock
435	93141	Screw, Diaphragm Cover			
455	225502	Cup, Flywheel			RPM Settings: Low: 1200 - 1600 High: 3500 - 3700
456	281503	Plate, Pawl Friction			
459	281505	Pawl, Ratchet			
526	94914	Screw, Hex	*		Indicates Parts Included in Gasket Set (494550)
527	223786	Clamp, Breather Tube	**		Indicates Parts Included in Carburetor Overhaul Kit (495606)
528	491435	Filter, Air	∅		Indicates Parts Included in Valve Overhaul Gasket Set (292638)
529	67838	Grommet, Breather Tube			
535	491435	Filter, Air			
536	494279	Air Cleaner Kit			
542	94897	Screw, Hex Head			
608	499706	Starter Assembly, Rewind			
609	265715	Spring, Choke			
611	231067	Line, Fuel			
612	391813	Tube, Pickup			
621	296110	Switch, Stop			

**NOTE:** All component dimensions given in  
U.S. inches 1 inch = 25.4 mm

Get it fixed, at your home or ours!

For repair of major brand appliances **In your own home...**  
no matter who made it, no matter who sold it!

**1-800-4-MY-HOME**<sup>SM</sup> Anytime, day or night  
(1-800-469-4663)

[www.sears.com](http://www.sears.com)

To bring in products such as vacuums, lawn equipment and electronics  
for repair, call for the location of your nearest **Sears Parts & Repair Center**

**1-800-488-1222** Anytime, day or night

[www.sears.com](http://www.sears.com)

For the replacement parts, accessories and owner's manuals  
that you need to do-it-yourself, call **Sears PartsDirect**<sup>SM</sup>!

**1-800-366-PART** 6 a.m. - 11 p.m. CST,  
(1-800-366-7278) 7 days a week

[www.sears.com/partsdirect](http://www.sears.com/partsdirect)

To purchase or inquire about a Sears Service Agreement:

**1-800-827-6655**

7 a.m. - 5 p.m. CST, Mon. - Sat.

Para pedir servicio de reparación a domicilio,  
y para ordenar piezas con entrega a domicilio:

**1-888-SU-HOGAR**<sup>SM</sup>  
(1-888-784-6427)

Au Canada pour service en français:

**1-877-LE-FOYER**<sup>SM</sup>  
(1-877-533-6937)



© Sears, Roebuck and Co.

© Registered Trademark / <sup>TM</sup> Trademark of Sears, Roebuck and Co.  
© Marca Registrada / <sup>TM</sup> Marca de Fábrica de Sears, Roebuck and Co.

172054 Rev. 2 1.6.00 TR

Printed in U.S.A.