

WESLO

# CADENCE

DX3

Model No. WLTL11090

Serial No. \_\_\_\_\_

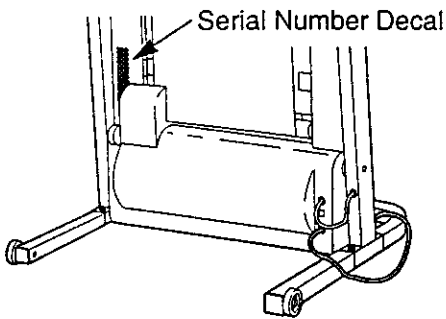

## USER'S MANUAL

### QUESTIONS?

As a manufacturer, we are committed to providing complete customer satisfaction. If you have questions, or if there are missing or damaged parts, we will guarantee complete satisfaction through direct assistance from our factory.

TO AVOID UNNECESSARY DELAYS, PLEASE CALL DIRECT TO OUR TOLL-FREE CUSTOMER HOT LINE. The trained technicians on our Customer Hot Line will provide immediate assistance, free of charge to you.

CUSTOMER HOT LINE:

**1-800-999-3756**

Mon.-Fri., 6 a.m.-6 p.m. MST

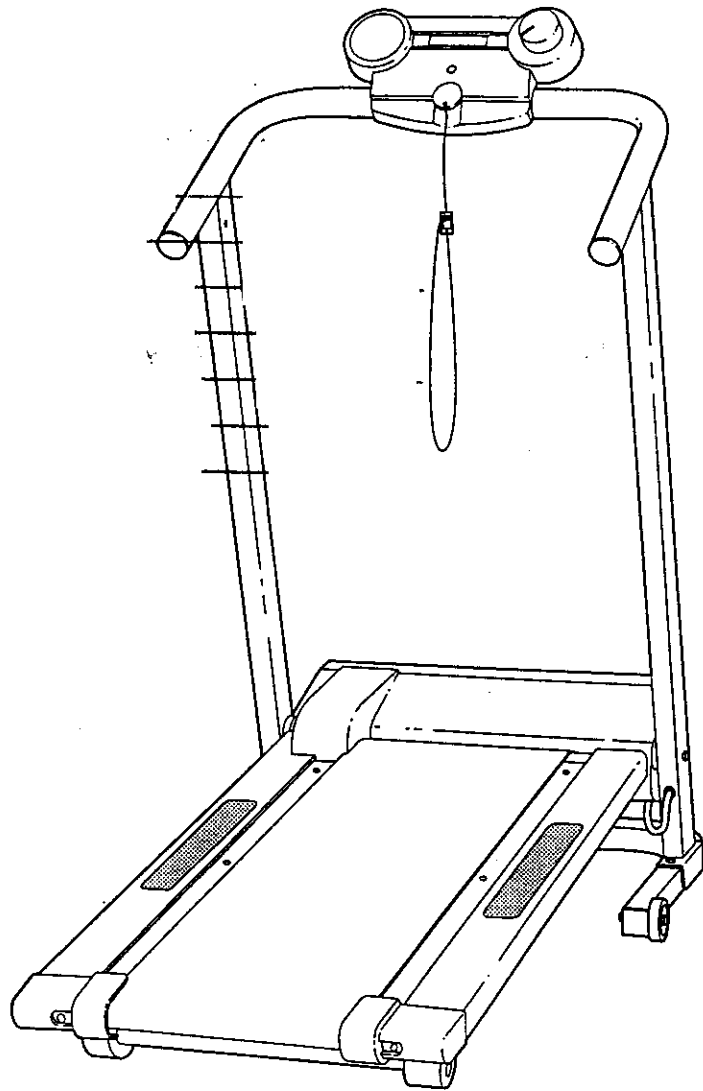

### ⚠ CAUTION

Read all precautions and instructions in this manual before using this equipment. Save this manual for future reference.



Visit our website at

[www.weslo.com](http://www.weslo.com)

*new products, prizes,  
fitness tips, and much more!*

# TABLE OF CONTENTS

IMPORTANT PRECAUTIONS	2
BEFORE YOU BEGIN	4
ASSEMBLY	5
OPERATION AND ADJUSTMENT	7
HOW TO FOLD AND MOVE THE TREADMILL	10
MAINTENANCE AND TROUBLE-SHOOTING	12
CONDITIONING GUIDELINES	14
ORDERING REPLACEMENT PARTS	Back Cover
LIMITED WARRANTY	Back Cover

Note: An EXPLODED DRAWING and a PART LIST are attached in the center of this manual. Please save them for future reference.

## IMPORTANT PRECAUTIONS

**▲ WARNING:** To reduce the risk of burns, fire, electric shock, or injury to persons, read the following important precautions and information before operating the treadmill.

1. It is the responsibility of the owner to ensure that all users of this treadmill are adequately informed of all warnings and precautions.
2. Use the treadmill only as described in this manual.
3. Place the treadmill on a level surface, with at least eight feet of clearance behind it. Do not place the treadmill on any surface that blocks air openings. To protect the floor or carpet from damage, place a mat under the treadmill.
4. Keep the treadmill indoors, away from moisture and dust. Do not put the treadmill in a garage or covered patio, or near water.
5. Do not operate the treadmill where aerosol products are used or where oxygen is being administered.
6. Keep children under the age of 12 and pets away from the treadmill at all times.
7. The treadmill should not be used by persons weighing more than 250 pounds.
8. Never allow more than one person on the treadmill at a time.
9. Wear appropriate exercise clothing when using the treadmill. Do not wear loose clothing that could become caught in the treadmill. Athletic support clothes are recommended for both men and women. *Always wear athletic shoes. Never use the treadmill with bare feet, wearing only stockings, or in sandals.*
10. When connecting the power cord (see page 7), plug the power cord into a surge protector (not included) and plug the surge protector into a grounded circuit capable of carrying 15 or more amps. No other appliance should be on the same circuit. Do not use an extension cord.
11. Use only a UL-listed surge protector, rated at 15 amps, with a 14-gauge cord of five feet or less in length. Do not use an extension cord.
12. Keep the power cord and the surge protector away from heated surfaces.
13. Never move the walking belt while the power is turned off. Do not operate the treadmill if the power cord or plug is damaged, or if the treadmill is not working properly. (See BEFORE YOU BEGIN on page 4 if the treadmill is not working properly.)
14. Never start the treadmill while you are standing on the walking belt. Always hold the handrails while using the treadmill.
15. The treadmill is capable of high speeds. Adjust the speed in small increments to avoid sudden jumps in speed.

16. Never leave the treadmill unattended while it is running. Always remove the key and unplug the power cord when the treadmill is not in use.

17. Do not attempt to raise, lower, or move the treadmill until it is properly assembled. (See ASSEMBLY on page 5, and HOW TO MOVE THE TREADMILL on page 10.) You must be able to safely lift 45 pounds (20 kg) in order to raise, lower, or move the treadmill.

18. Do not change the incline of the treadmill by placing objects under the treadmill.

19. When folding or moving the treadmill, make sure that the storage latch is fully closed.

20. Inspect and tighten all parts of the treadmill regularly.

21. Never drop or insert any object into any opening.

22. **DANGER:** Always unplug the power cord immediately after use, before cleaning the treadmill, and before performing the maintenance and adjustment procedures described in this manual. Never remove the motor hood unless instructed to do so by an authorized service representative. Servicing other than the procedures in this manual should be performed by an authorized service representative only.

23. This treadmill is intended for in-home use only. Do not use this treadmill in any commercial, rental, or institutional setting.

**⚠ WARNING:** Before beginning this or any exercise program, consult your physician. This is especially important for persons over the age of 35 or persons with pre-existing health problems. Read all instructions before using. ICON assumes no responsibility for personal injury or property damage sustained by or through the use of this product.

## SAVE THESE INSTRUCTIONS

The decals shown have been placed on your treadmill. If a decal is missing, or if it is not legible, please call our Customer Service Department, toll-free, to order a free replacement decal (see ORDERING REPLACEMENT PARTS on the back cover of this manual). Apply the decal in the location shown.

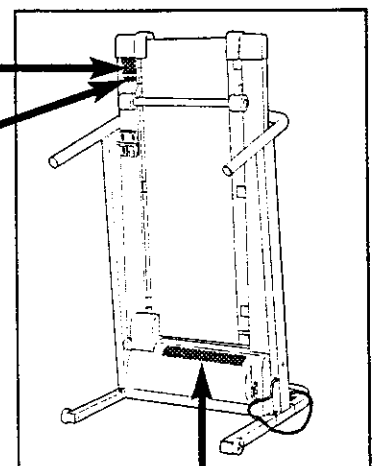
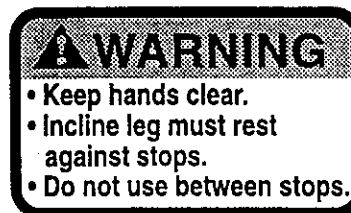

Note: The decal below is shown at 38% of actual size.

**⚠ WARNING:** Protect yourself and others from risk of serious injury. Read the user's manual and:

- Fully engage storage latch before treadmill is moved or stored.
- Reduce incline to lowest level before folding treadmill into storage position.
- Stand only on side rails when starting or stopping treadmill.
- Change speed in small increments.
- Hold handrails to prevent falling, and always wear the safety clip while operating treadmill.
- Stop if you feel faint, dizzy, or short of breath.
- Never allow children on or around treadmill.
- Remove key when not in use.
- Keep clothing, fingers, and hair away from moving belt.
- Never try to adjust or fix the belt while it is moving.
- Always wear athletic shoes while operating treadmill.



# BEFORE YOU BEGIN

Thank you for selecting the WESLO® CADENCE DX3 treadmill. The CADENCE DX3 treadmill combines advanced technology with innovative design to let you enjoy an excellent form of cardiovascular exercise in the convenience and privacy of your home. And when you're not exercising, the unique CADENCE DX3 can be folded up, requiring less than half the floor space of other treadmills.

please call our Customer Service Department toll-free at 1-800-999-3756, Monday through Friday, 6 a.m. until 6 p.m. Mountain Time (excluding holidays). To help us assist you, please note the product model number and serial number before calling. The model number of the treadmill is WLT11090. The serial number can be found on a decal attached to the treadmill (see the front cover of this manual for the location).

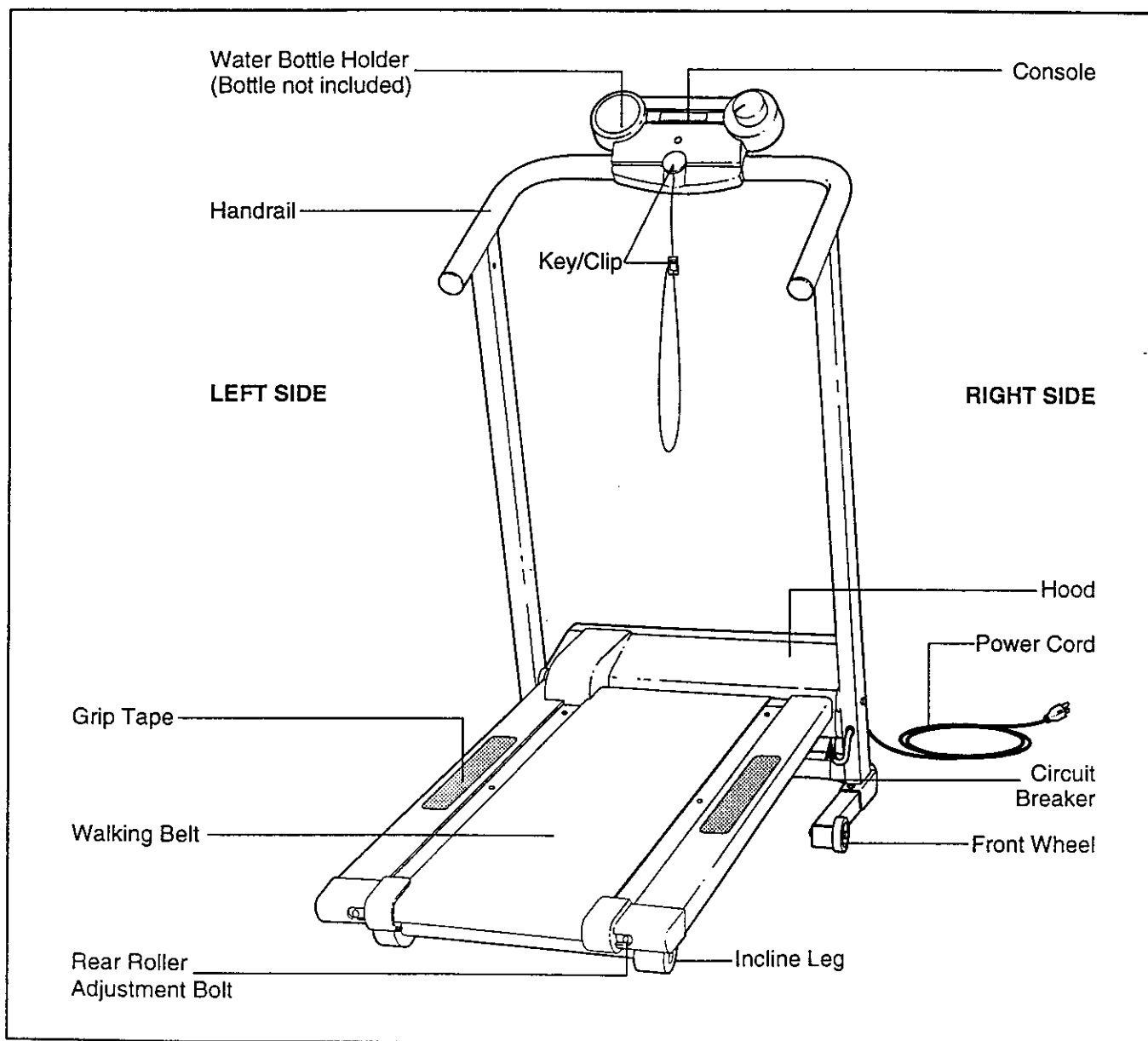

**For your benefit, read this manual carefully before using the treadmill.** If you have additional questions,

Before reading further, please review the drawing below and familiarize yourself with the labeled parts.

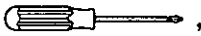

# ASSEMBLY

**Assembly requires two persons.** Set the treadmill in a cleared area and remove all packing materials; **do not dispose of the packing materials until assembly is completed.** Note: The underside of the treadmill walking belt is coated with high-performance lubricant. During shipping, a small amount of lubricant may be transferred to the top of the walking belt or the shipping carton. This does not affect treadmill performance. If there is lubricant on top of the walking belt, simply wipe off the lubricant with a soft cloth and a mild, non-abrasive cleaner.

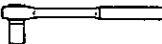
Assembly requires the included allen wrench  and your own phillips screwdriver , two adjustable wrenches  and 9/16 socket wrench .

1. With the help of a second person, carefully raise the Right and Left Handrails (6, 7) to the position shown. Be careful not to pull on the Wire Harness (22) as you raise the Uprights.

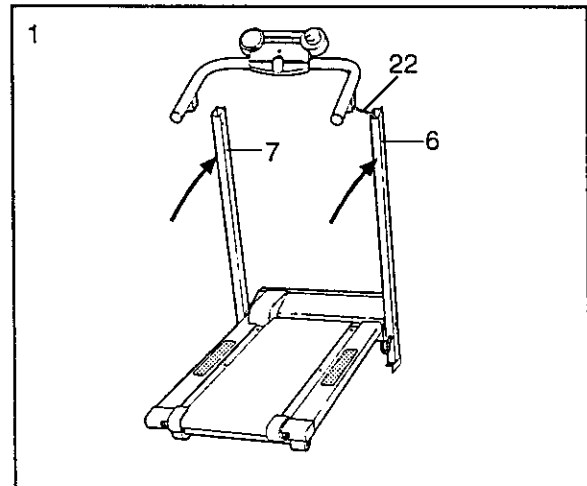

2. With the help of a second person, carefully tip the treadmill onto its right side. Hold the Base (80) against the Left Upright (7) and the Right Upright (not shown). **Make sure the Base Pads (19) are on the bottom.**

Using a 9/16 socket wrench and an adjustable wrench, attach the Base (80) to the Left Upright (7) with two Upright Bolts (84), two Washers (11), and two Upright Nuts (17). **Do not tighten the Upright Bolts yet.** Attach the Base to the Right Upright (not shown) with two Upright Bolts (12), two Washers (11), and two Upright Nuts (17). Then, tighten all four Upright Bolts (84).

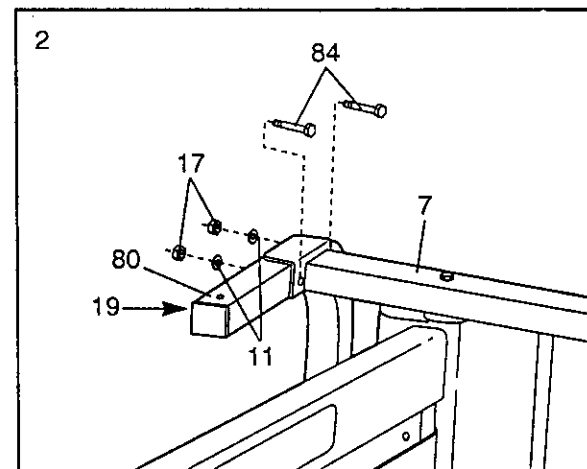

Tip the treadmill back to the position shown in step 1.

3. Insert the Wire Harness (22) into the Right Upright (7) as you insert the Handrail (16) into the Right and Left Uprights (7, 6). **Be careful not to pinch the Wire Harness.** Tighten a Handrail Bolt (12) with a Washer (11) into each Upright.

Loosen the two Console Bolts (9) underneath the Console (1). Rotate the Console to the position shown and tighten the two Console Bolts.

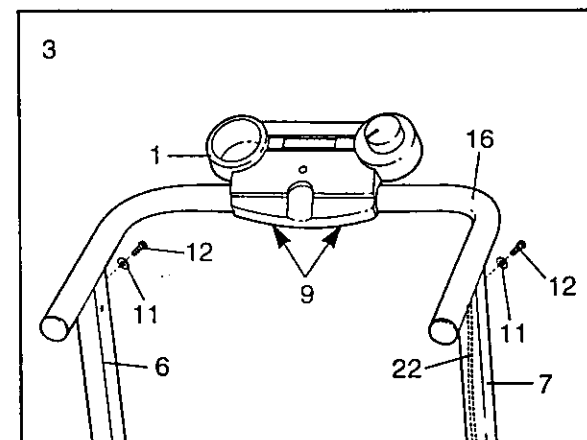

4. Using two adjustable wrenches, attach the Wheels (15) to the Base (80) with the two Wheel Bolts (14) and the two Wheel Nuts (42) as shown. **Do not overtighten the Bolts. The Wheels should turn freely.**

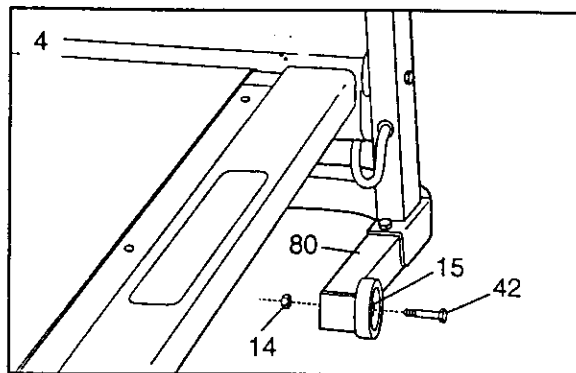

5. **Note: You must be able to safely lift 45 pounds (20 kg) in order to do this step.**

Hold the treadmill with your hands in the locations shown. **Caution: To decrease the possibility of injury, bend your legs and keep your back straight. As you raise the treadmill, make sure to lift with your legs rather than your back.** Raise the treadmill to the vertical position.

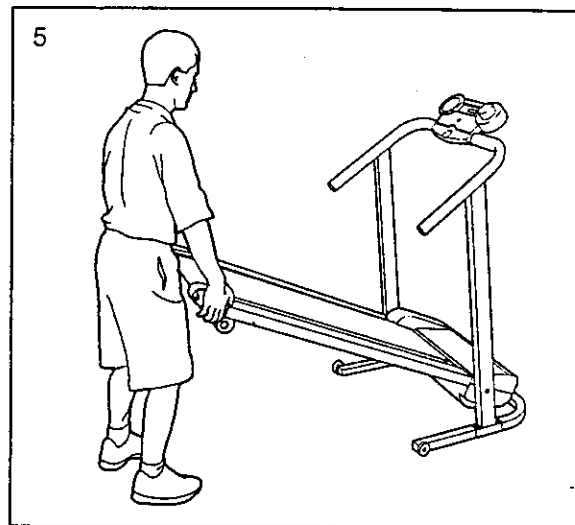

6. Make sure that the Latch Pin (78) is placed in the Storage Latch (77) as shown.

Attach the Storage Latch (77) to the Frame (55) with the three Screws (5). **Do not fully tighten the Screws yet.** Position the Latch so that the Latch Pin (78) is aligned with the hole in the Left Upright (7). Slide the Latch Pin into the hole as shown in the inset drawing. Then, tighten the three Screws.

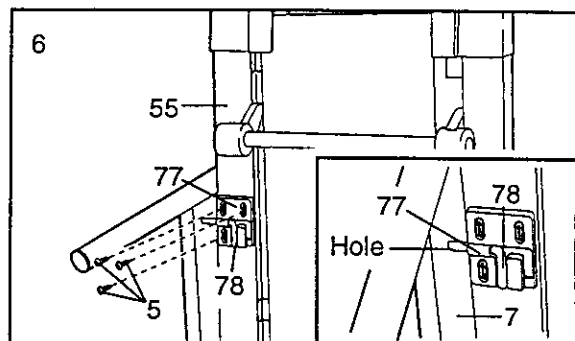

7. The console requires two "AA" batteries (not included). Alkaline batteries are recommended. To install batteries, first **touch the Handrail (16) to discharge any static.** Next, open the Battery Cover (8). Press the batteries into the battery compartment, with the negative (-) ends of the batteries touching the springs. Close the battery cover, push up on the tab, and then push the tab forward as shown in the inset drawing. Be sure that the tab locks into place.

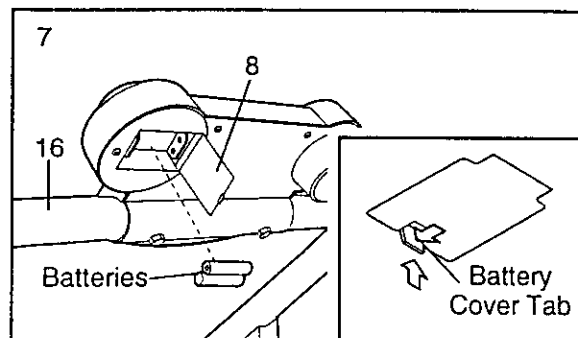

8. **Make sure that all parts are tightened before you use the treadmill.** Keep the included allen wrench in a secure place. The allen wrench is used to adjust the walking belt (see page 13). To protect the floor or carpet, place a mat under the treadmill.

# OPERATION AND ADJUSTMENT

## THE PERFORMANT LUBE™ WALKING BELT

Your treadmill features a walking belt coated with PERFORMANT LUBE™, a high-performance lubricant. **IMPORTANT:** Never apply silicone spray or other substances to the walking belt or the walking platform. They will deteriorate the walking belt and cause excessive wear.

## HOW TO PLUG IN THE POWER CORD

**⚠ DANGER:** Improper connection of the equipment-grounding conductor can result in an increased risk of electric shock. Check with a qualified electrician or serviceman if you are in doubt as to whether the product is properly grounded. Do not modify the plug provided with the product—if it will not fit the outlet, have a proper outlet installed by a qualified electrician.

Your treadmill, like any other type of sophisticated electronic equipment, can be seriously damaged by sudden voltage changes in your home's power. Voltage surges, spikes, and noise interference can result from weather conditions or from other appliances being turned on or off.

**To decrease the possibility of your treadmill being damaged, always use a surge protector (not included) with your treadmill.**

Surge protectors are sold at most hardware stores and department stores. Use only a UL-listed surge protector, rated at 15 amps, with a 14-gauge cord of five feet or less in length.

**This product must be grounded.** If it should malfunction or break down, grounding provides a path of least resistance for electric current to reduce the risk of

electric shock. This product is equipped with a cord having an equipment-grounding conductor and a grounding plug. **Plug the power cord into a surge protector, and plug the surge protector into an appropriate outlet that is properly installed and grounded in accordance with all local codes and ordinances.**

This product is for use on a nominal 120-volt circuit, and has a grounding plug that looks like the plug illustrated in drawing 1 below. A temporary adapter that looks like the adapter illustrated in drawing 2 may be used to connect the surge protector to a 2-pole receptacle as shown in drawing 2 if a properly grounded outlet is not available.

The temporary adapter should be used only until a properly grounded outlet (drawing 1) can be installed by a qualified electrician.

The green-colored rigid ear, lug, or the like extending from the adapter must be connected to a permanent ground such as a properly grounded outlet box cover. Whenever the adapter is used it must be held in place by a metal screw. **Some 2-pole receptacle outlet box covers are not grounded. Contact a qualified electrician to determine if the outlet box cover is grounded before using an adapter.**

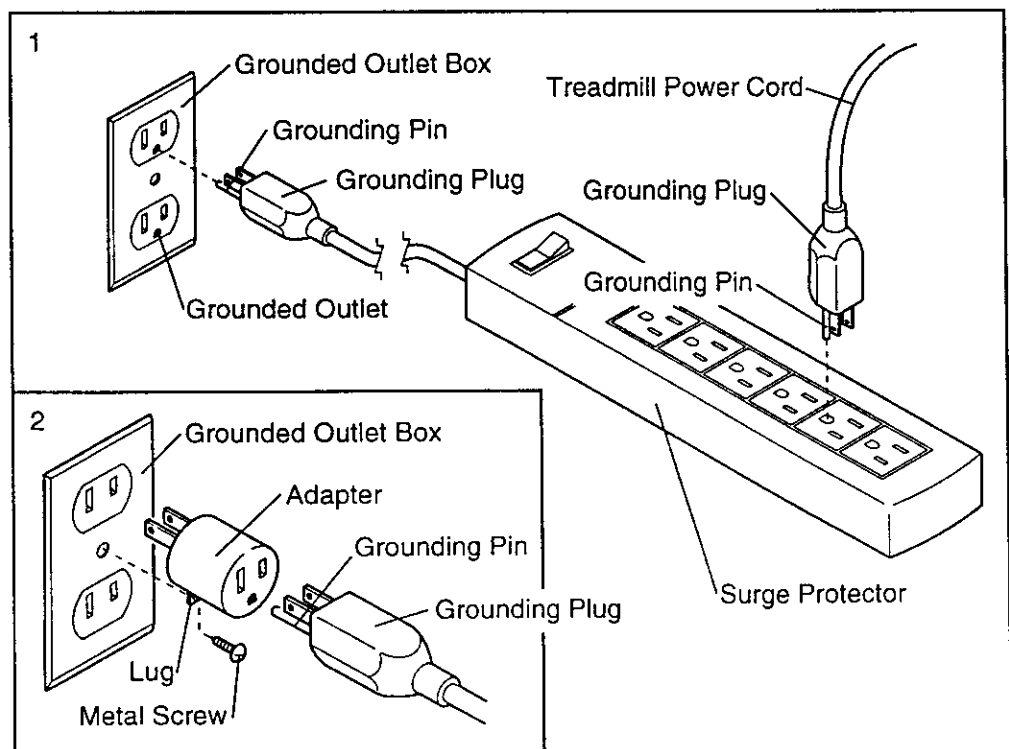

## DIAGRAM OF THE CONSOLE

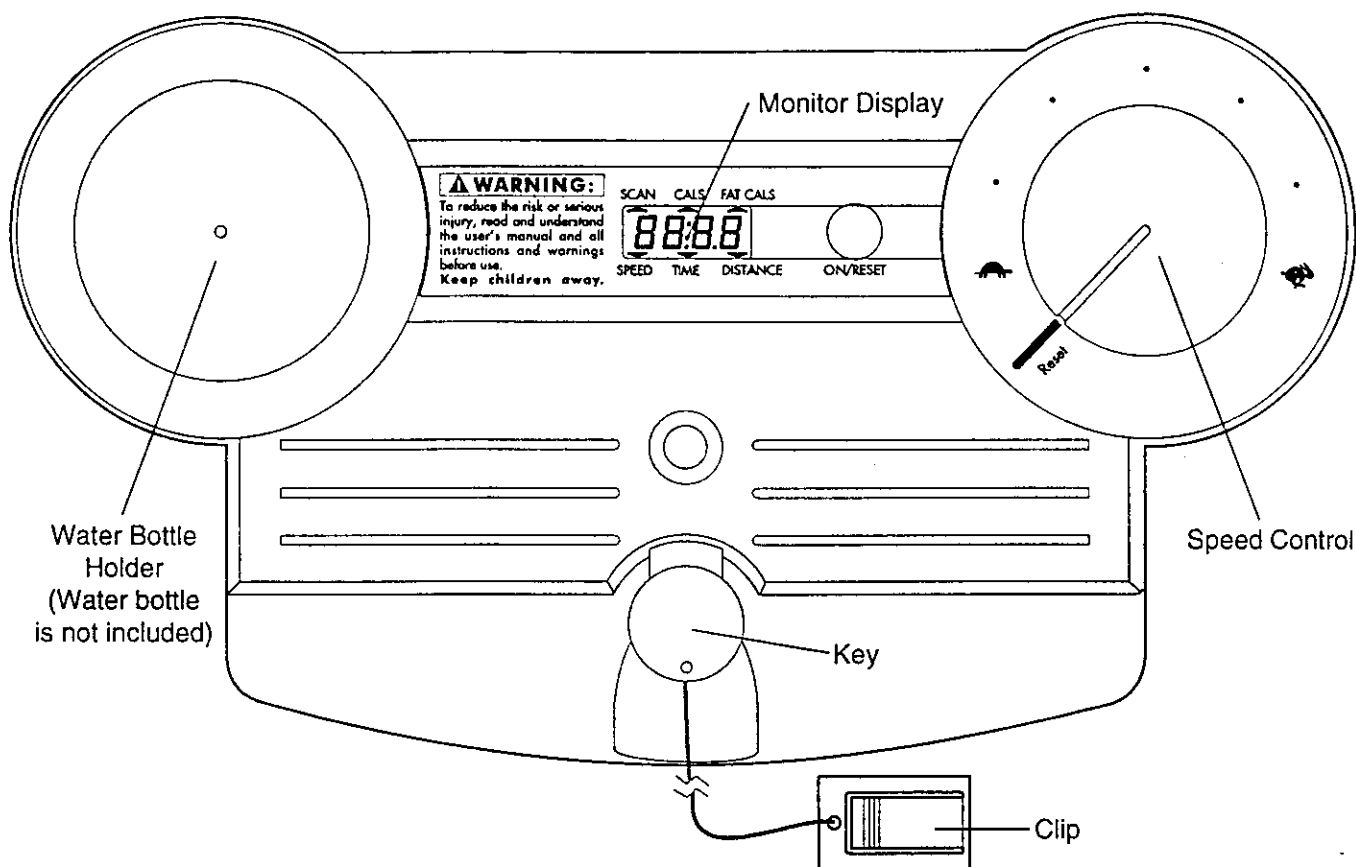

### **⚠ CAUTION:** Before operating the console, read the following precautions.

- Do not stand on the walking belt when turning on the power.
- Always wear the clip (see the drawing above) while operating the treadmill. When the key is removed from the console, the walking belt will stop.
- Adjust the speed in small increments.
- To reduce the possibility of electric shock, keep the console dry. Avoid spilling liquids on the console and use only a sealable water bottle.

## STEP BY STEP CONSOLE OPERATION

Before the console can be operated, two "AA" batteries must be installed (see assembly step 6 on page 6). Follow the steps below to operate the console.

Step onto the grip tape on the treadmill. Find the clip attached to the key (see the drawing above), and slide the clip onto the waistband of your clothing.

Follow the steps at the right and on page 9 to operate the console.

### **1** Insert the key fully into the power switch.

Note: Inserting the key will not turn on the display. The display will turn on when the ON/RESET button is pressed or when the walking belt is started. (If you just installed batteries, the display will already be on.)

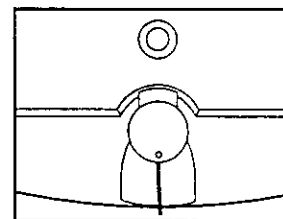



## 2 Reset the console and start the walking belt.

Turn the speed control to the RESET position. **Note: Each time the walking belt is stopped, the speed control must be turned to the RESET position before the walking belt can be restarted.**

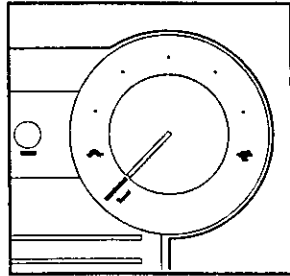

Next, slowly turn the speed control until the walking belt begins to move at slow speed. Carefully step onto the walking belt and begin exercising. Change the speed of the walking belt as desired by turning the speed control.

To stop the walking belt, step onto the foot rails and turn the speed control to the RESET position.

## 3 Follow your progress with the monitor modes

When the power is turned on, the console will automatically scan through four modes. A flashing mode indicator will show which mode is currently displayed. The modes are described below.

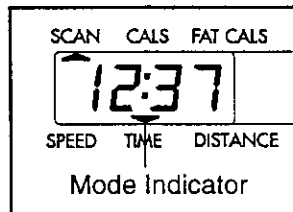

- **Speed**—This mode shows your speed, in miles per hour.
- **Time**—This mode shows the elapsed time. Note: If you stop exercising for ten seconds or longer, the time mode will pause.
- **Distance**—This mode shows the total number of miles you have walked or run.
- **Calories (CALC)**—This mode shows the approximate number of calories you have burned.
- **Fat Calories (FAT CALC)**—This mode shows the approximate number of fat calories you have burned. (See BURNING FAT on page 14.)

If desired, reset the display by pressing the ON/RESET button.

## 4 When you are finished exercising, stop the walking belt and remove the key.

Step onto the grip tape, stop the walking belt and remove the key from the console. The displays will turn off about six minutes after the key is removed. **Note: The display will automatically turn off in order to conserve the batteries any time that the walking belt is stopped and the ON/RESET button is not pressed for six minutes.**

## HOW TO CHANGE THE INCLINE OF THE TREADMILL

To vary the intensity of your exercise, the incline of the treadmill can be changed. There are two different incline levels. **Before changing the incline, remove the key and unplug the power cord.**

To change the incline, raise the back of the treadmill and rotate the incline leg until it rests against the treadmill frame.

**CAUTION:** Before using the treadmill, make sure that the frame is resting on the incline leg.

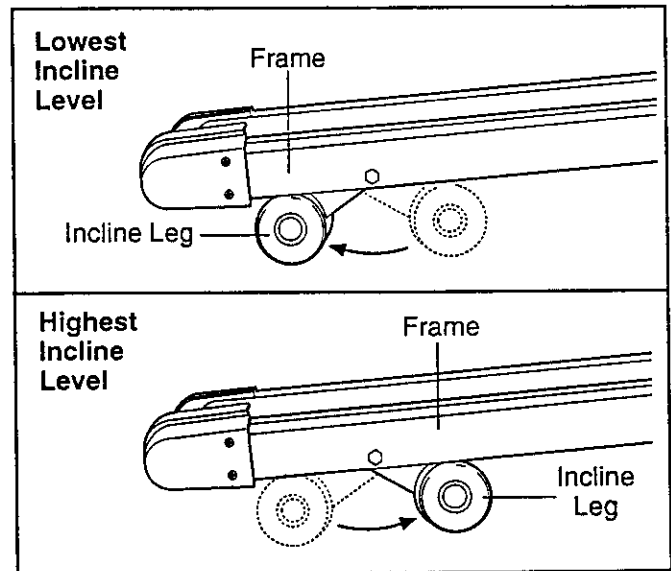

# HOW TO FOLD AND MOVE THE TREADMILL

## HOW TO FOLD THE TREADMILL FOR STORAGE

Unplug the power cord. **Caution: You must be able to safely lift 45 pounds (20 kg) in order to raise, lower, or move the treadmill.**

1. Hold the treadmill with your hands in the locations shown at the right. **Caution: To decrease the possibility of injury, bend your legs and keep your back straight. As you raise the treadmill, make sure to lift with your legs rather than your back.** Raise the treadmill about halfway to the vertical position.

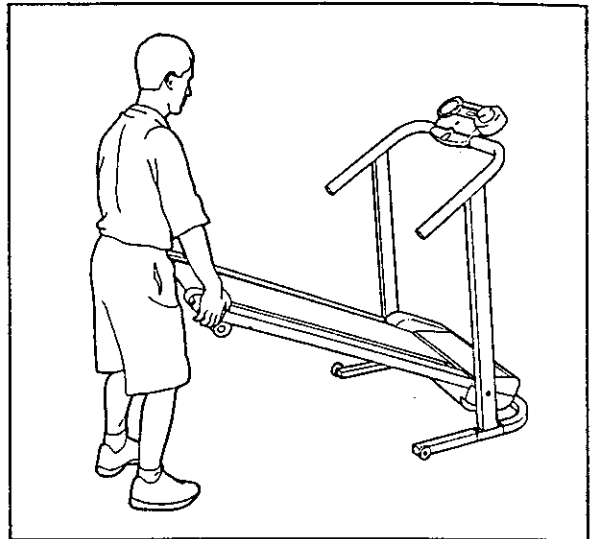

2. Move your right hand to the position shown and hold the treadmill firmly. Raise the treadmill until the latch pin is aligned with the hole in the handrail. Slide the latch pin into the hole. **Make sure that the latch pin is inserted as far as possible into the hole.** Lock the pin by pressing the end of the pin into the slot in the storage latch as shown in the inset drawing.

**To protect the floor or carpet from damage, place a mat under the treadmill. Keep the treadmill out of direct sunlight. Do not leave the treadmill in the storage position in temperatures above 85° Fahrenheit.**

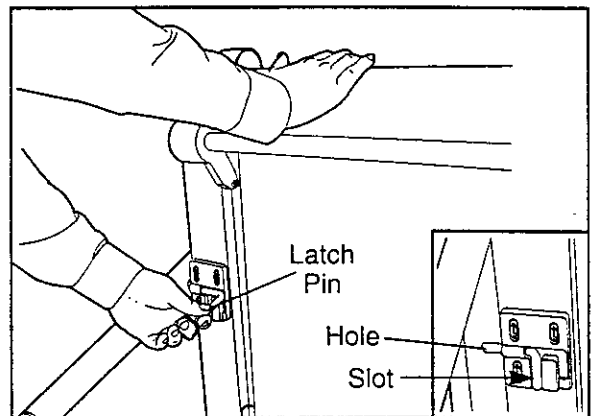

## HOW TO MOVE THE TREADMILL

Before moving the treadmill, convert the treadmill to the storage position as described above. **Make sure that the latch pin is fully inserted into the hole in the handrail and locked into place as described above.**

1. Hold the handrails and place one foot on the base as shown.
2. Tilt the treadmill back until it rolls freely on the front wheels. Carefully move the treadmill to the desired location. **Never move the treadmill without tipping it back. To reduce the risk of injury, use extreme caution while moving the treadmill. Do not attempt to move the treadmill over an uneven surface.**
3. Place one foot on the base, and carefully lower the treadmill until it is resting in the storage position.

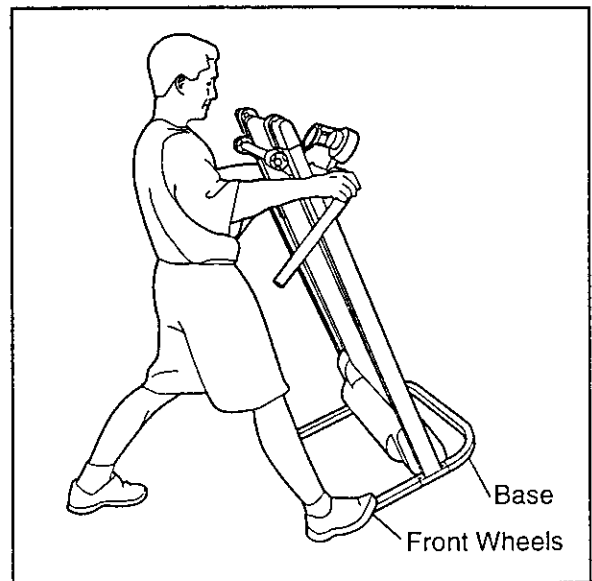

## HOW TO LOWER THE TREADMILL FOR USE

1. Hold the upper end of the treadmill with your right hand as shown. Using your left hand, slide the latch pin to the right. Lock the pin in place by pressing the end of the pin into the slot in the storage latch as shown in the inset drawing.

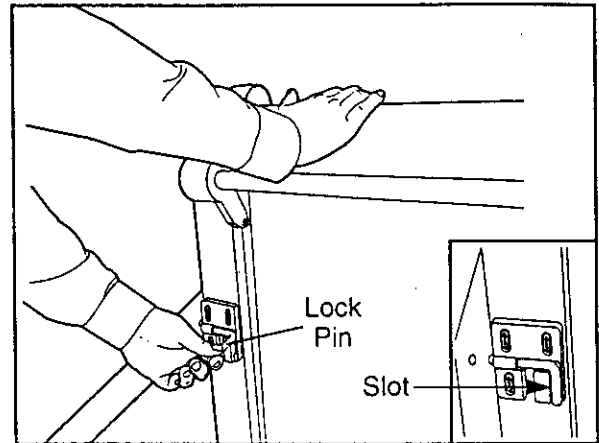

2. Hold the treadmill firmly with both hands, and lower the treadmill to the floor. **To decrease the possibility of injury, bend your legs and keep your back straight.**

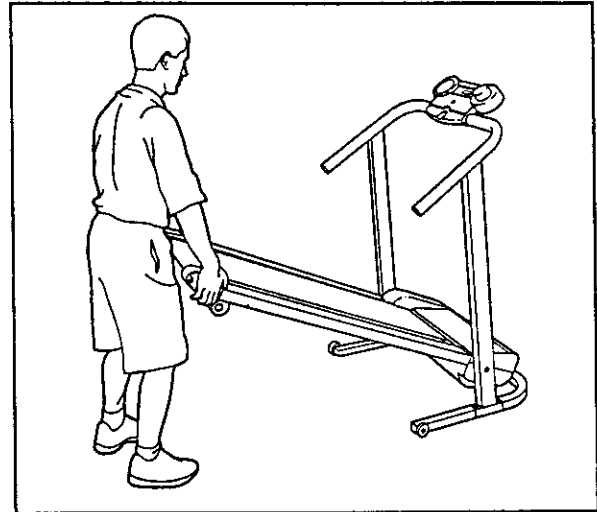

# MAINTENANCE AND TROUBLE-SHOOTING

Most treadmill problems can be solved by following the steps below. Find the symptom that applies, and follow the steps listed. If further assistance is needed, please call our Customer Service Department toll-free at 1-800-999-3756, Monday through Friday, 6 a.m. until 6 p.m. Mountain Time (excluding holidays).

## PROBLEM: The power does not turn on

**SOLUTION:** a. Make sure that the power cord is plugged into a surge protector, and that the surge protector is plugged into a properly grounded outlet. (See HOW TO PLUG IN THE POWER CORD on page 7.) Use only a UL-listed surge protector, rated at 15 amps, with a 14-gauge cord of five feet or less in length.

b. After the power cord has been plugged in, make sure that the key is fully inserted into the console. (See step 1 on page 8.)

c. Check the circuit breaker located on the treadmill near the power cord. If the switch protrudes as shown, the circuit breaker has tripped. To reset the circuit breaker, wait for five minutes and then press the switch back in.

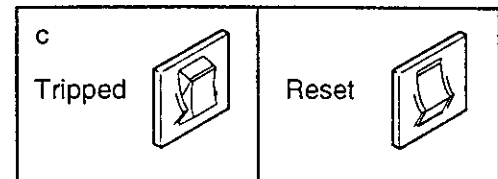

## PROBLEM: The power turns off during use

**SOLUTION:** a. Check the circuit breaker located on the treadmill frame near the power cord (see 1. c. above). If the circuit breaker has tripped, wait for five minutes and then press the switch back in.

b. Make sure that the power cord is plugged in.

c. Remove the key from the console. Reinsert the key fully into the console. (See step 1 on page 8.)

d. If the treadmill still will not run, please call our Customer Service Department, toll-free.

## PROBLEM: The displays of the console do not function properly

**SOLUTION:** a. Check the batteries in the console. See assembly step 6 on page 6. Most problems are the result of drained batteries.

b. Remove the key from the console and **UNPLUG THE POWER CORD**. Remove the screws from the hood. Carefully remove the hood. Locate the Reed Switch (46) and the Magnet (49) on the left side of the Pulley (53). Turn the Pulley until the Magnet is aligned with the Reed Switch. **Make sure that the gap between the Magnet and the Reed Switch is about 1/8"**. If necessary, loosen the Screw (26) and move the Reed Switch slightly. Retighten the Screw. Re-attach the hood, and run the treadmill for a few minutes to check for a correct speed reading.

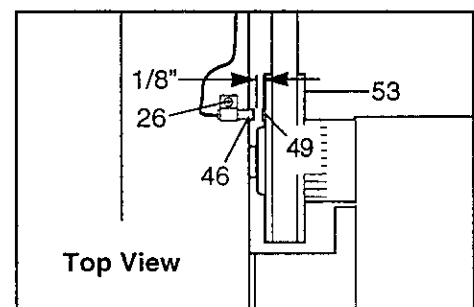

**PROBLEM: The walking belt is off-center**

**SOLUTION:** a. If the walking belt has shifted to the left, first remove the key and **UNPLUG THE POWER CORD**. Using the allen wrench, turn the right adjustment bolt counterclockwise 1/4 of a turn. Plug in the power cord, insert the key and run the treadmill for a few minutes. Repeat until the walking belt is centered.

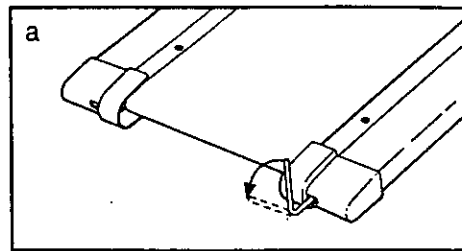

b. If the walking belt has shifted to the right, first remove the key and **UNPLUG THE POWER CORD**. Using the allen wrench, turn the right adjustment bolt clockwise 1/4 of a turn. Plug in the power cord, insert the key and run the treadmill for a few minutes. Repeat until the walking belt is centered.

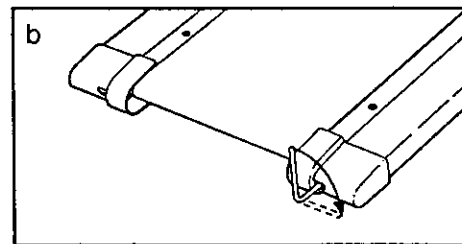

# CONDITIONING GUIDELINES

**⚠ WARNING:** Before beginning this or any exercise program, consult your physician. This is especially important for individuals over the age of 35 or individuals with pre-existing health problems.

The following guidelines will help you to plan your exercise program. Remember—these are general guidelines. For more detailed information about exercise, obtain a book or consult your physician.

## EXERCISE INTENSITY

Whether your goal is to burn fat or strengthen your cardiovascular system, the key to achieving the desired results is to exercise with the proper intensity. The proper intensity level can be found by using your heart rate as a guide. For effective exercise, your heart rate should be maintained at a level between 70% and 85% of your maximum heart rate as you exercise. This is known as your training zone.

You can find your training zone in the table below. Training zones are listed according to age and physical condition.

Age	Training Zone (Beats/Min.)	
	Unconditioned	Conditioned
20	138-167	133-162
25	136-166	132-160
30	135-164	130-158
35	134-162	129-156
40	132-161	127-155
45	131-159	125-153
50	129-156	124-150
55	127-155	122-149
60	126-153	121-147
65	125-151	119-145
70	123-150	118-144
75	122-147	117-142
80	120-146	115-140
85	118-144	114-139

## Burning Fat

To burn fat, you must exercise at a low intensity level for a sustained period of time. During the first few minutes of exercise, your body uses easily accessible *carbohydrate* calories for energy. Only after the first few minutes of exercise does your body begin to use stored *fat* calories for energy. If your goal is to burn fat, adjust the intensity of your exercise until your heart rate is near the low end of your training zone as you exercise.

## Aerobic Exercise

If your goal is to strengthen your cardiovascular system, your exercise must be "aerobic." Aerobic exercise is activity that requires large amounts of oxygen for prolonged periods of time. This increases the demand on the heart to pump blood to the muscles, and on the lungs to oxygenate the blood. For aerobic exercise, adjust the intensity of your exercise until your heart rate is near the middle of your training zone.

## HOW TO MEASURE YOUR HEART RATE

To measure your heart rate, place two fingers on your wrist as shown. Stop exercising and take a six-second heartbeat count. Multiply the result

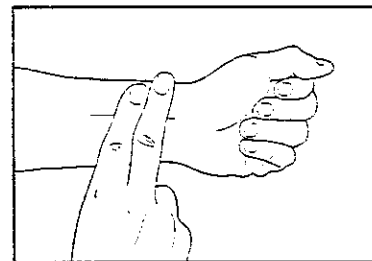

by ten to find your heart rate. (A six-second count is used because your heart rate drops quickly when you stop exercising.) If your heart rate is too high, decrease the intensity of your exercise. If your heart rate is too low, increase the intensity of your exercise.

## WORKOUT GUIDELINES

Each workout should include three basic parts: (1) a warm-up, (2) training zone exercise, and (3) a cool-down.

## Warming Up

Warming up prepares the body for exercise by increasing circulation, delivering more oxygen to the muscles and raising the body temperature. Begin each workout with 5 to 10 minutes of stretching and light exercise to warm up (see SUGGESTED STRETCHES on page 15).

## Training Zone Exercise

After warming up, increase the intensity of your exercise until your pulse is in your training zone for 20 to 60 minutes. (During the first few weeks of your exercise program, do not keep your pulse in your training zone for longer than 20 minutes.) Breathe regularly and deeply as you exercise—never hold your breath.

## Cooling Down

Finish each workout with 5 to 10 minutes of stretching

to cool down. This will increase the flexibility of your muscles and will help to prevent post-exercise problems.

## Exercise Frequency

To maintain or improve your condition, complete three workouts each week, with at least one day of rest between workouts. After a few months, you may complete up to five workouts each week if desired.

*The key to success is to make exercise a regular and enjoyable part of your everyday life.*

## SUGGESTED STRETCHES

The correct form for several basic stretches is shown at the right. Move slowly as you stretch—never bounce.

### 1. Toe Touch Stretch

Stand with your knees bent slightly and slowly bend forward from your hips. Allow your back and shoulders to relax as you reach down toward your toes as far as possible. Hold for 15 counts, then relax. Repeat 3 times. Stretches: Hamstrings, back of knees, and back.

### 2. Hamstring Stretch

Sit with one leg extended. Bring the sole of the opposite foot toward you and rest it against the inner thigh of your extended leg. Reach toward your toes as far as possible. Hold for 15 counts, then relax. Repeat 3 times for each leg. Stretches: Hamstrings, lower back, and groin.

### 3. Calf/Achilles Stretch

With one leg in front of the other, reach forward and place your hands against a wall. Keep your back leg straight and your back foot flat on the floor. Bend your front leg, lean forward and move your hips toward the wall. Hold for 15 counts, then relax. Repeat 3 times for each leg. To cause further stretching of the achilles tendons, bend your back leg as well. Stretches: Calves, achilles tendons, and ankles.

### 4. Quadriceps Stretch

With one hand against a wall for balance, reach back and grasp one foot with your other hand. Bring your heel as close to your buttocks as possible. Hold for 15 counts, then relax. Repeat 3 times for both legs. Stretches: Quadriceps and hip muscles.

### 5. Inner Thigh Stretch

Sit with the soles of your feet together and your knees outward. Pull your feet toward your groin area as far as possible. Hold for 15 counts, then relax. Repeat 3 times. Stretches: Quadriceps and hip muscles.

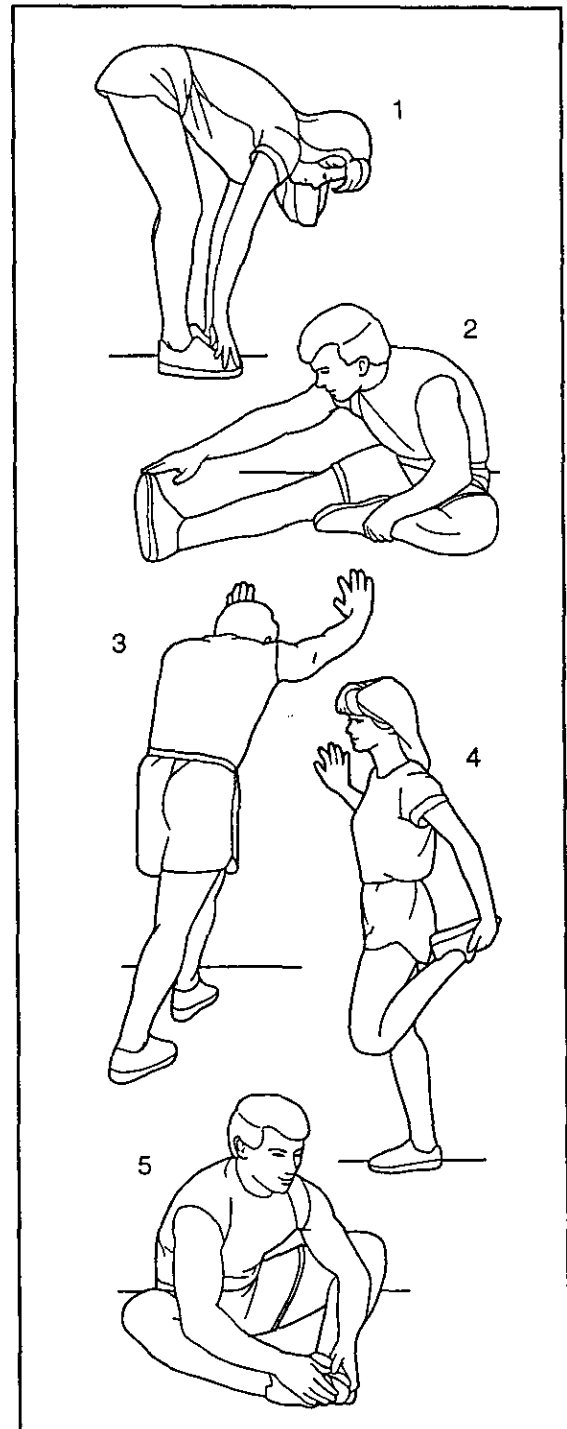

# EXPLODED DRAWING—Model No. WLTL39091

R1199A

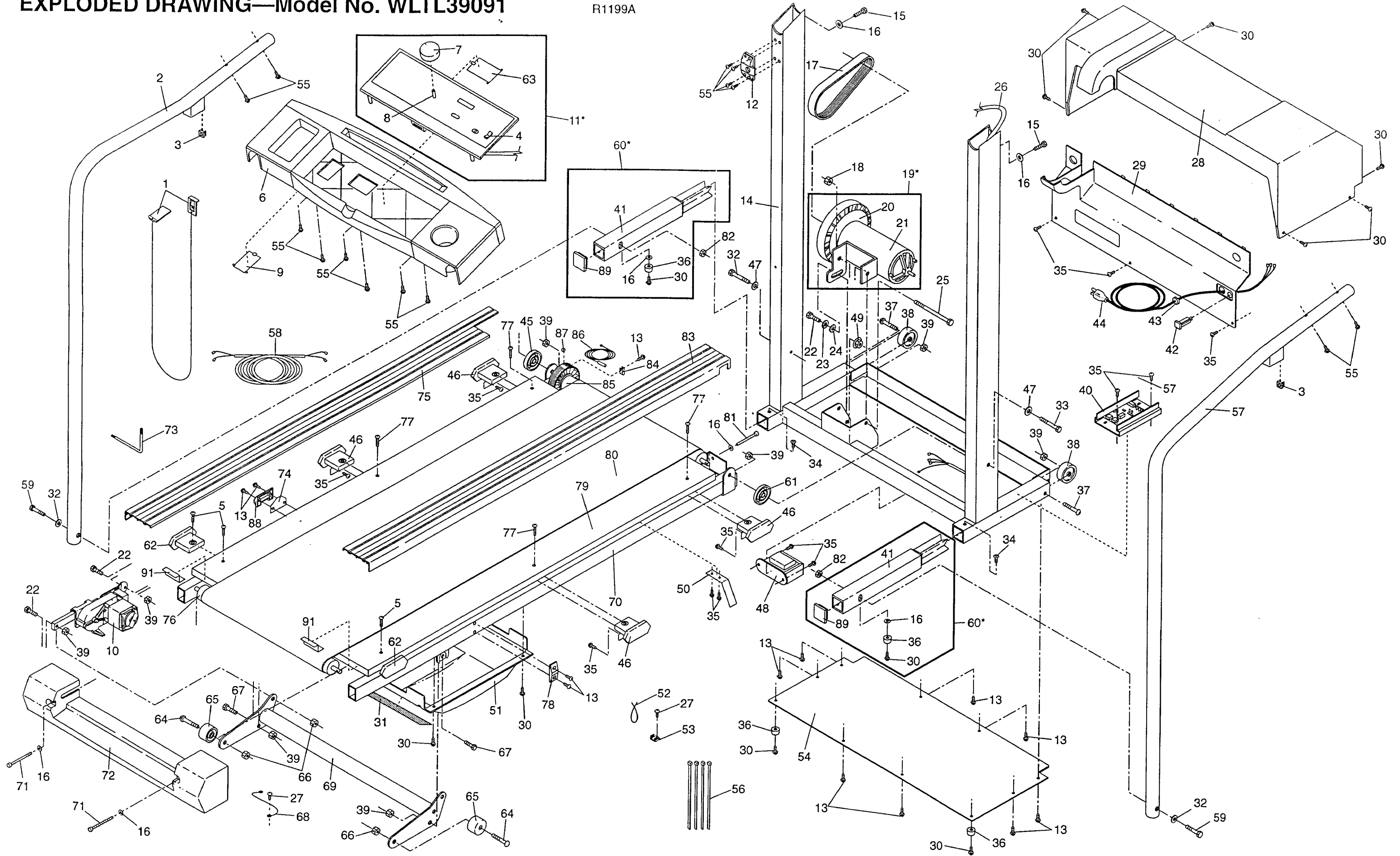



# PART LIST—Model No. WLTL39091

R1199A

Key No.	Qty.	Description	Key No.	Qty.	Description
1	1	Key/Clip	49	1	Motor Locknut
2	1	Left Handrail	50	2	Belt Guide
3	2	Cage Nut	51	1	Belly Pan
4	1	Incline Control	52	1	Releasable Tie
5	4	Rear Isolator Screw	53	2	Cable Tie Clamp
6	1	Console Base	54	1	Motor Belly Pan
7	1	Speed Control Knob	55	18	Screw
8	1	Speed Potentiometer	56	4	8" Wire Tie
9	1	Battery Cover	57	1	Right Handrail
10	1	Incline Motor	58	1	Incline Wire Harness
11*	1	Console Assembly	59	2	3 1/2" Handrail Bolt
12	1	Storage Latch	60	2	Extension Leg Assembly
13	10	1/2" Screw	61	1	Right Upright Spacer
14	1	Upright/Base	62	2	Rear Isolator
15	2	Handrail Bolt	63	1	Latch Catch
16	7	Handrail Washer/Roller Washer	64	2	Incline Wheel Bolt
17	1	Motor Belt	65	2	Incline Wheel
18	1	Motor Swivel Nut	66	4	Incline Leg Nut
19*	1	Motor/Pulley/Flywheel/Fan	67	2	Incline Pivot Bolt
20	1	Pulley/Flywheel/Fan	68	1	Ground Wire
21	1	Motor	69	1	Incline Leg
22	4	Motor Tension Bolt/Incline Bolt	70	1	Frame
23	1	Motor Tension Washer	71	2	Rear Roller Adj. Bolt
24	1	Motor Tension Star Washer	72	1	Rear Roller Endcap
25	1	Motor Swivel Bolt	73	1	Allen Wrench
26	1	Wire Harness	74	1	Latch Catch Spacer
27	2	Ground Wire Screw	75	1	Left Foot Rail
28	1	Hood	76	1	Rear Roller
29	1	Hood Shield	77	4	Platform Screw
30	16	Small Screw	78	1	Frame Guide
31	1	Warning Decal	79	1	Walking Platform
32	4	Handrail Washer	80	1	Walking Belt
33	2	Frame Pivot Bolt	81	1	Front Roller Adjustment Bolt
34	2	Extension Leg Screw	82	2	Handrail Nut
35	10	Electronics Screw	83	1	Right Foot Rail
36	6	Base Pad	84	1	Sensor Clip
37	2	Wheel Bolt	85	1	Front Roller/Pulley
38	2	Wheel	86	1	Reed Switch
39	7	Wheel Nut/Base Pivot Nut	87	1	Magnet
40	1	Controller	88	1	Latch Catch
41	2	Extension Leg	89	2	Extension Leg Endcap
42	1	Circuit Breaker	#	1	4" White Wire, Pig Tail
43	1	Power Cord Grommet	#	1	8" Blue Wire, Pig Tail
44	1	Power Cord	#	1	User's Manual
45	1	Left Upright Spacer			
46	4	Isolator			
47	2	Frame Pivot Washer			
48	1	Choke			

\* Includes all parts shown in the box  
# These parts are not illustrated

**REMOVE THIS EXPLODED DRAWING  
AND PART LIST FROM THE MANUAL.  
Save this page for future reference.**

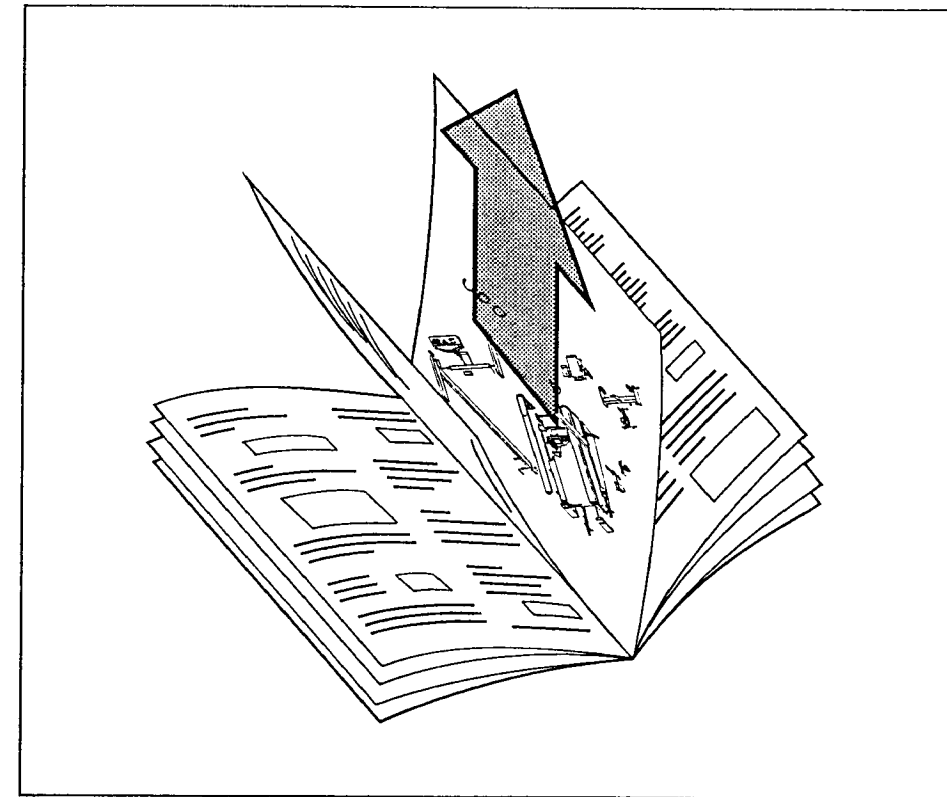

Note: Specifications are subject to change without notice. For information about ordering replacement parts, see the back cover of the User's Manual.

# ORDERING REPLACEMENT PARTS

To order replacement parts, call our Customer Service Department toll-free at 1-800-999-3756, Monday through Friday, 6 a.m. until 6 p.m. Mountain Time (excluding holidays). When ordering parts, please be prepared to give the following information:

- The MODEL NUMBER of the product (WLTL11090)
- The NAME of the product (WESLO® CADENCE DX3 treadmill)
- The SERIAL NUMBER of the product (see the front cover of this manual)
- The KEY NUMBER and DESCRIPTION of the desired part(s) (see the PART LIST and the EXPLODED DRAWING in the center of this manual)

If possible, place the treadmill near your telephone for easy reference when calling.

WESLO is a registered trademark of ICON Health & Fitness, Inc.

## LIMITED WARRANTY

ICON Health & Fitness, Inc. (ICON), warrants this product to be free from defects in workmanship and material, under normal use and service conditions, for a period of ninety (90) days from the date of purchase. This warranty extends only to the original purchaser. ICON's obligation under this warranty is limited to replacing or repairing, at ICON's option, the product at one of its authorized service centers. All products for which warranty claim is made must be received by ICON at one of its authorized service centers with all freight and other transportation charges prepaid, accompanied by sufficient proof of purchase. All returns must be pre-authorized by ICON. This warranty does not extend to any product or damage to a product caused by or attributable to freight damage, abuse, misuse, improper or abnormal usage or repairs not provided by an ICON authorized service center, to products used for commercial or rental purposes, or to products used as store display models. No other warranty beyond that specifically set forth above is authorized by ICON.

ICON is not responsible or liable for indirect, special or consequential damages arising out of or in connection with the use or performance of the product or damages with respect to any economic loss, loss of property, loss of revenues or profits, loss of enjoyment or use, costs of removal, installation or other consequential damages of whatsoever nature. Some states do not allow the exclusion or limitation of incidental or consequential damages. Accordingly, the above limitation may not apply to you.

The warranty extended hereunder is in lieu of any and all other warranties and any implied warranties of merchantability or fitness for a particular purpose is limited in its scope and duration to the terms set forth herein. Some states do not allow limitations on how long an implied warranty lasts. Accordingly, the above limitation may not apply to you.

This warranty gives you specific legal rights. You may also have other rights which vary from state to state.

**ICON HEALTH & FITNESS, INC., 1500 S. 1000 W., LOGAN, UT 84321-9813**