

Owner's Manual

CRAFTSMAN®
6.0 HORSEPOWER
22" REAR DISCHARGE
ROTARY LAWN MOWER

Model No.
917.377170

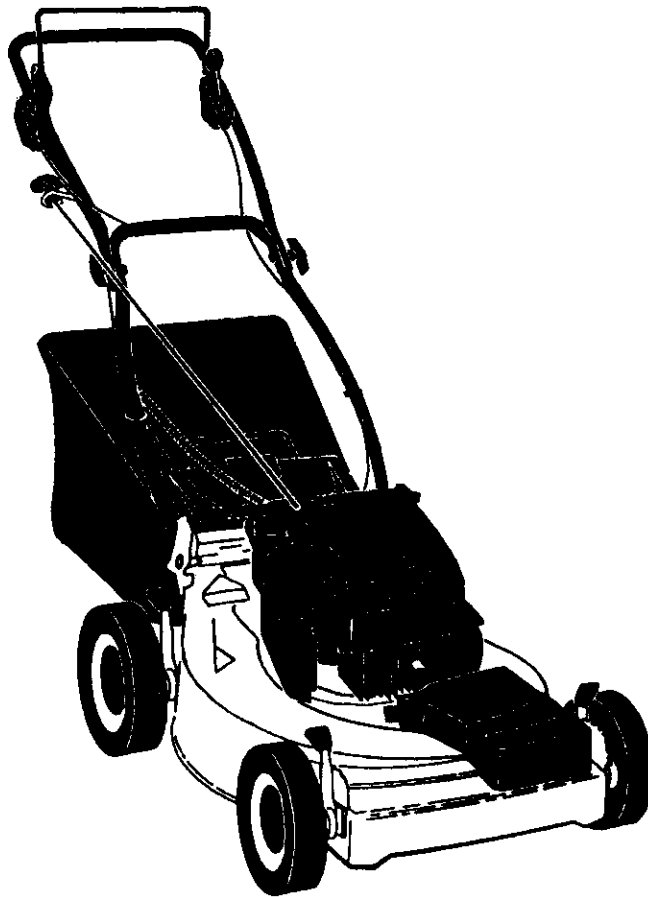

- **Safety**
- **Assembly**
- **Operation**
- **Maintenance**
- **Español**
- **Repair Parts**

CAUTION:

Read and follow all
Safety Rules and Instructions
before operating this equipment

Sears, Roebuck and Co., Hoffman Estates, IL 60179
Visit our Craftsman website: www.sears.com/craftsman

TABLE OF CONTENTS

Warranty	2	Product Specifications	11
Safety Rules	2	Service and Adjustments	14
Assembly	4	Storage	16
Operation	6	Troubleshooting	17
Maintenance Schedule	10	Repair Parts	36
Maintenance	10	Parts Ordering	Back Cover

WARRANTY

LIMITED TWO YEAR WARRANTY ON CRAFTSMAN POWER MOWER

For two years from date of purchase, when this Craftsman Lawn Mower is maintained, lubricated, and tuned up according to the operating and maintenance instructions in the owner's manual, Sears will repair free of charge any defect in material or workmanship.

If this Craftsman Lawn Mower is used for commercial or rental purposes, this warranty applies for only 90 days from the date of purchase.

This Warranty does not cover:

- Expendable items which become worn during normal use, such as rotary mower blades, blade adapters, belts, air cleaners and spark plug.
- Repairs necessary because of operator abuse or negligence, including bent crankshafts and the failure to maintain the equipment according to the instructions contained in the owner's manual.

Warranty service is available by returning the Craftsman power mower to the nearest Sears Service Center/Department in the United States. This warranty applies only while this product is in use in the United States.

This Warranty gives you specific legal rights, and you may also have other rights which vary from state to state.

SEARS, ROEBUCK AND CO., D/817 WA, HOFFMAN ESTATES, ILLINOIS 60179

SAFETY RULES

Safety standard's require operator presence controls to minimize the risk of injury. Your unit is equipped with such controls. Do not attempt to defeat the function of the operator presence controls under any circumstances.

TRAINING:

- Read this operator's manual carefully. Become familiar with the controls and know how to operate your mower properly. Learn how to quickly stop mower.
- Do not allow children to use your mower. Never allow adults to use mower without proper instructions.
- Keep the area of operation clear of all persons, especially small children and pets.
- Use mower only as the manufacturer intended and as described in this manual.

- Do not operate mower if it has been dropped or damaged in any manner. Always have damage repaired before using your mower.
- Do not use accessory attachments that are not recommended by the manufacturer. Use of such attachments may be hazardous.
- The blade turns when the engine is running.

PREPARATION:

- Always thoroughly check the area to be mowed and clear it of all stones, sticks, wires, bones, and other foreign objects. These objects will be thrown by the blade and can cause severe injury.
- Always wear safety glasses or eye shields when starting and while using your mower.

- Dress properly. Do not operate mower when barefoot or wearing open sandals. Wear only solid shoes with good traction when mowing.
- Check fuel tank before starting engine. Do not fill gas tank indoors, when the engine is running or when the engine is hot. Allow the engine to cool for several minutes before filling the gas tank. Clean off any spilled gasoline before starting the engine.
- Always make wheel height adjustments before starting your mower. Never attempt to do this while the engine is running.
- Mow only in daylight or good artificial light.

OPERATION:

- Keep your eyes and mind on your mower and the area being cut. Do not let other interests distract you.
- Do not mow wet or slippery grass. Never run while operating your mower. Always be sure of your footing - keep a firm hold on the handles and walk.
- Do not put hands or feet near or under rotating parts. Keep clear of the discharge opening at all times.
- Always stop the engine whenever you leave or are not using your mower, or before crossing driveways, walks, roads, and any gravel-covered areas.
- Never direct discharge of material toward bystanders nor allow anyone near the mower while you are operating it.
- Before cleaning, inspecting, or repairing your mower, stop the engine and make absolutely sure the blade and all moving parts have stopped. Then disconnect the spark plug wire and keep it away from the spark plug to prevent accidental starting.
- Do not continue to run your mower if you hit a foreign object. Follow the procedure outlined above, then repair any damage before restarting and operating your mower.
- Do not change the governor settings or overspeed the engine. Engine damage or personal injury may result.
- Do not operate your mower if it vibrates abnormally. Excessive vibration is an indication of damage; stop the engine, safely check for the cause of vibration and repair as required.

- Do not run the engine indoors. Exhaust fumes are dangerous.
- Never cut grass by pulling the mower towards you. Mow across the face of slopes, never up and down or you might lose your footing. Do not mow excessively steep slopes. Use caution when operating the mower on uneven terrain or when changing directions - maintain good footing.
- Never operate your mower without proper guards, plates, grass catcher or other safety devices in place.

MAINTENANCE AND STORAGE:

- Check the blade and the engine mounting bolts often to be sure they are tightened properly.
- Check all bolts, nuts and screws at frequent intervals for proper tightness to be sure mower is in safe working condition.
- Keep all safety devices in place and working.
- To reduce fire hazard, keep the engine free of grass, leaves or excessive grease and oil.
- Check grass catcher often for deterioration and wear and replace worn bags. Use only replacement bags that are recommended by and comply with specifications of the manufacturer of your mower.
- Always keep a sharp blade on your mower.
- Allow engine to cool before storing in any enclosure.
- Never store mower with fuel in the tank inside a building where fumes may reach an open flame or an ignition source such as a hot water heater, space heater, clothes dryer, etc.

⚠ Look for this symbol to point out important safety precautions. It means **CAUTION!!! BECOME ALERT!!! YOUR SAFETY IS INVOLVED.**



⚠ CAUTION: Always disconnect spark plug wire and place wire where it cannot contact spark plug in order to prevent accidental starting when setting up, transporting, adjusting or making repairs.

⚠ WARNING: The engine exhaust from this product contains chemicals known to the State of California to cause cancer, birth defects, or other reproductive harm.



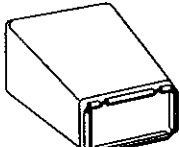
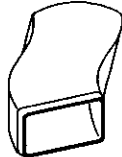
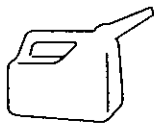

ACCESSORIES

These accessories were available when this lawn mower was produced. They are not shipped with your mower. They are also available at most Sears retail outlets and service centers. Most Sears stores can also order repair parts for you, when you provide the model number of your lawn mower. Some of these accessories may not apply to your lawn mower.

LAWN MOWER PERFORMANCE

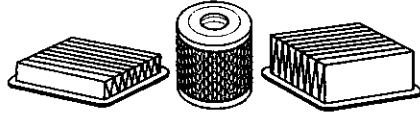
 CLIPPING DEFLECTOR FOR REAR DISCHARGE LAWN MOWERS	 MULCHER KITS	 STABILIZER
 GRASS CATCHERS FOR REAR DISCHARGE LAWN MOWERS	 GRASS CATCHERS FOR SIDE DISCHARGE LAWN MOWERS	 GAS CANS

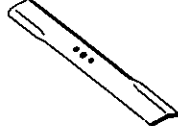
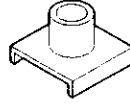
LAWN MOWER MAINTENANCE

 MUFFLERS	 AIR FILTERS	 SPARK PLUGS
 BELTS	 BLADES	 BLADE ADAPTERS
 WHEELS	 ENGINE OIL	

ASSEMBLY

Read these instructions and this manual in its entirety before you attempt to assemble or operate your new lawn mower.

IMPORTANT: This lawn mower is shipped without oil or gasoline in the engine.

Your new lawn mower has been assembled at the factory with the exception of those parts left unassembled for shipping purposes. To ensure safe and proper operation of your lawn mower, all parts and hardware you assemble must be tightened securely. Use the correct tools as necessary to ensure proper tightness. All parts such as nuts, washers, bolts, etc., necessary to complete the assembly have been placed in the parts bag.

TO REMOVE LAWN MOWER FROM CARTON

- Remove loose parts included with mower.
- Cut down two end corners of carton and lay end panel down flat.
- Remove all packing materials except padding between upper and lower handle and padding holding operator presence control bar to upper handle.
- Roll lawn mower out of carton and check carton thoroughly for additional loose parts.

HOW TO SET UP YOUR LAWN MOWER TO UNFOLD HANDLE

IMPORTANT: Unfold handles carefully so as not to pinch or damage control cables

- Raise handles until lower handle section locks into place in mowing position.
- Remove protective padding, raise upper handle section into place on lower handle and tighten both handle knobs.
- Remove handle padding holding operator presence control bar to upper handle.
- Your lawn mower handle can be adjusted for your mowing comfort. Refer to "Adjust Handle" in the Service and Adjustment section of this manual.

Operator presence control bar

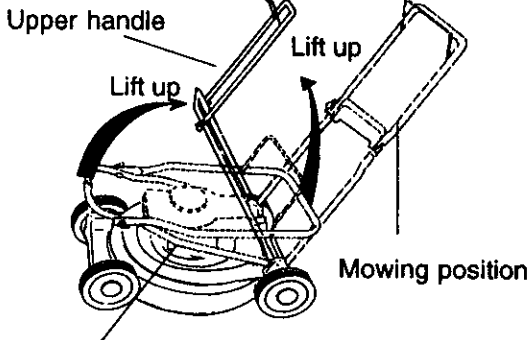

Lower handle

TO INSTALL ATTACHMENTS

Your lawn mower was shipped ready to be used as a mulcher. To convert to bagging or discharging:

- Open rear door and remove mulcher plug. Store mulcher plug in a safe place.
- You can now install catcher or optional clipping deflector.
- To return to mulching operation, install mulcher plug into discharge opening of mower.

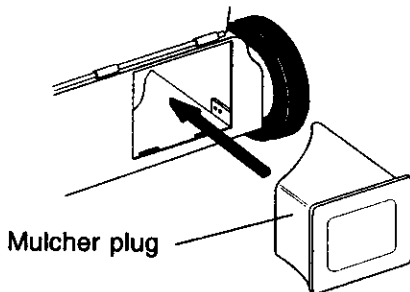

CAUTION: Do not run your lawn mower without mulcher plug in place or approved clipping deflector or grass catcher in place. Never attempt to operate the lawn mower with the rear door removed or propped open.

TO PREPARE BATTERY

NOTE: Your battery must be charged before you can start your lawn mower.

- Disconnect engine battery connector (male) from battery connector (female)
 - Connect battery charger connector (male) to battery connector (female).
 - Plug battery charger into 110 volt A.C. outlet.
 - Leave battery charger connected for 24 hours before starting your engine for the first time.
 - After charging, connect engine connector (male) to battery connector (female).
- Your engine has an integral alternator for partial charging. Connect your battery charger to charge battery as required.

IMPORTANT: The engine alternator will not charge a discharged battery.

At the end of the mowing season the battery should be charged for 48 hours to protect the battery during winter storage.

CAUTION: Always disconnect the engine connector (male) from the battery connector (female) to prevent accidental starting when transporting or storing your lawn mower after the season.

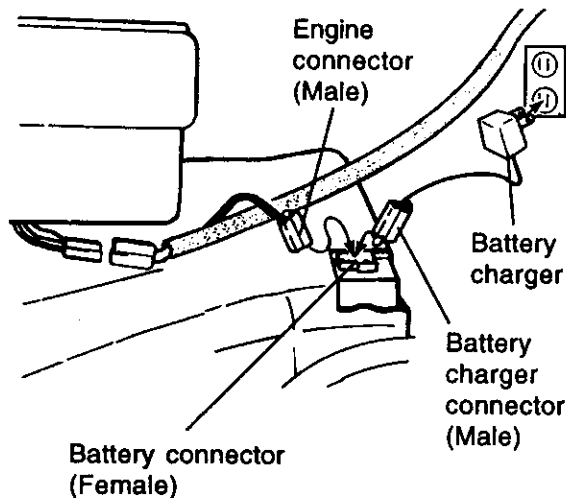

OPERATION

KNOW YOUR LAWN MOWER

READ THIS OWNER'S MANUAL AND SAFETY RULES BEFORE OPERATING YOUR LAWN MOWER. Compare the illustrations with your lawn mower to familiarize yourself with the location of various controls and adjustments. Save this manual for future

These symbols may appear on your lawn mower or in literature supplied with the product. Learn and understand their meaning.

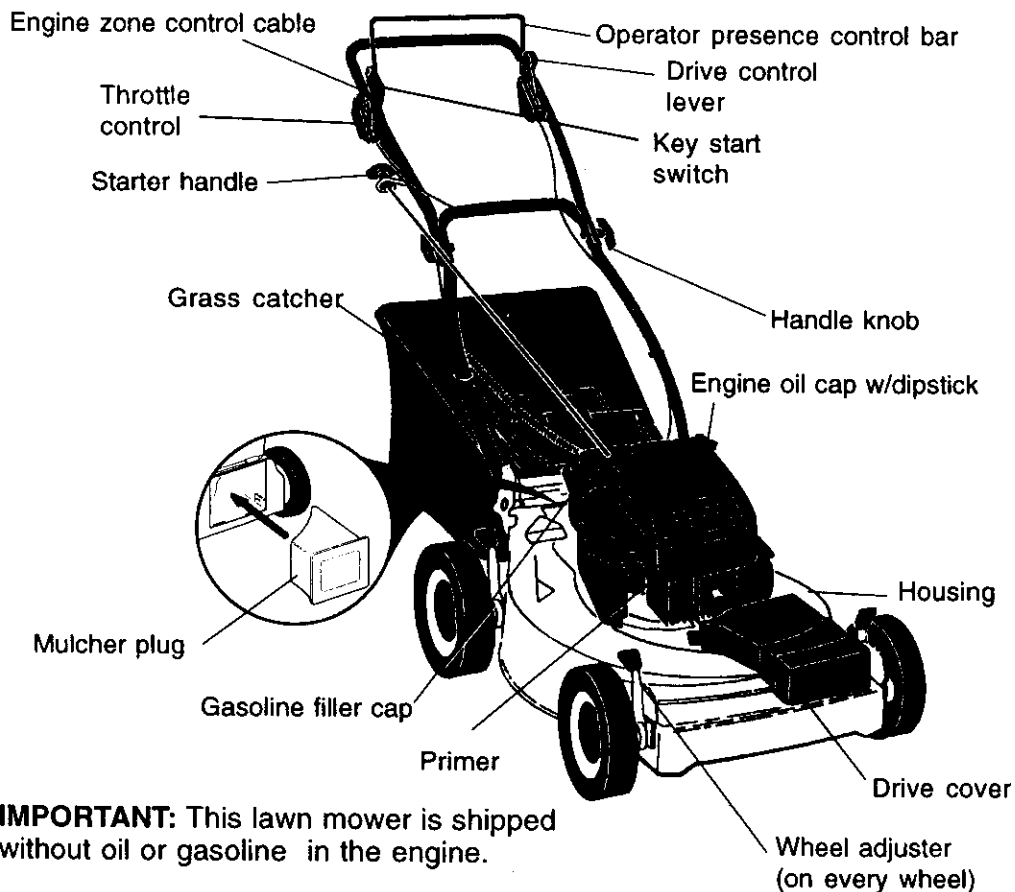
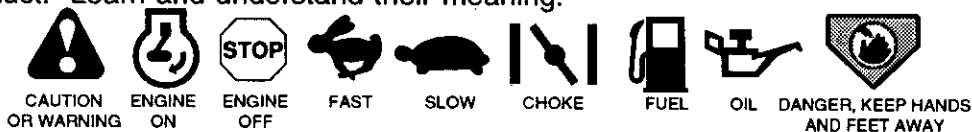

IMPORTANT: This lawn mower is shipped without oil or gasoline in the engine.

MEETS CPSC SAFETY REQUIREMENTS

Sears rotary walk-behind power lawn mowers conform to the safety standards of the American National Standards Institute and the U.S. Consumer Product Safety Commission. The blade turns when the engine is running.

Operator presence control bar - must be held down to the handle to start the engine. Release to stop the engine.

Primer - pumps additional fuel from the carburetor to the cylinder for use when starting a cold engine.

Starter handle - used for starting the engine.

Key start switch - used for starting the engine

Drive control lever - used to engage power-propelled forward motion of lawn mower.

Mulcher plug - must be removed to convert to bagging or discharging operation.

Throttle control - Used for starting the engine and allows you to select either fast or slow engine speed.



The operation of any lawn mower can result in foreign objects thrown into the eyes, which can result in severe eye damage. Always wear safety glasses or eye shields while operating your lawn mower or performing any adjustments or repairs. We recommend a wide vision safety mask over spectacles or standard safety glasses.

HOW TO USE YOUR LAWN MOWER ENGINE SPEED

The engine speed is controlled by a throttle located on the side of the upper handle. Fast position is for starting, normal cutting, trimming and better grass bagging. Slow position is for light cutting, trimming and fuel economy.

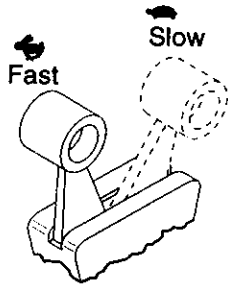

ENGINE ZONE CONTROL

CAUTION: Federal regulations require an engine control to be installed on this lawn mower in order to minimize the risk of blade contact injury. Do not under any circumstances attempt to defeat the function of the operator control. The blade turns when the engine is running.

- Your lawn mower is equipped with an operator presence control bar which requires the operator to be positioned behind the lawn mower handle to start and operate the lawn mower.

TO ADJUST CUTTING HEIGHT

- Raise wheels for low cut and lower wheels for high cut.
- Adjust cutting height to suit your requirements. Medium position is best for most lawns.
- To change cutting height, squeeze adjuster lever toward wheel. Move wheel up or down to suit your requirements. Be sure all wheels are in the same setting.

NOTE: Adjuster is properly positioned when plate tab inserts into hole in lever. Also, 9-position adjusters (if so equipped) allow lever to be positioned between the plate tabs.

Lower Wheels for High Cut Plate Tab

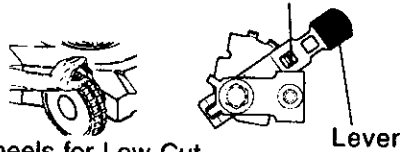

Raise Wheels for Low Cut

TO ATTACH GRASS CATCHER

- Lift the rear door of the lawn mower and place the grass catcher frame hooks onto the door pivot pins.
- The grass catcher is secured to the lawn mower housing when the rear door is lowered onto the grass catcher frame.

CAUTION: Do not run your lawn mower without clipping deflector or approved grass catcher in place. Never attempt to operate the lawn mower with the rear door removed or propped open.

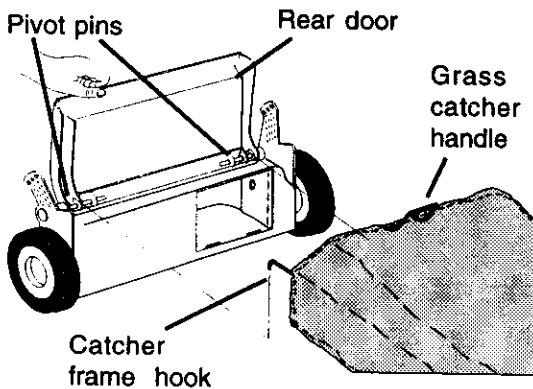

TO EMPTY GRASS CATCHER

- Lift up on grass catcher using the frame handle.
- Remove grass catcher with clippings from under lawn mower handle.
- Empty clippings from bag using both frame handle and bag handle.

NOTE: Do not drag the bag when emptying; it will cause unnecessary wear.

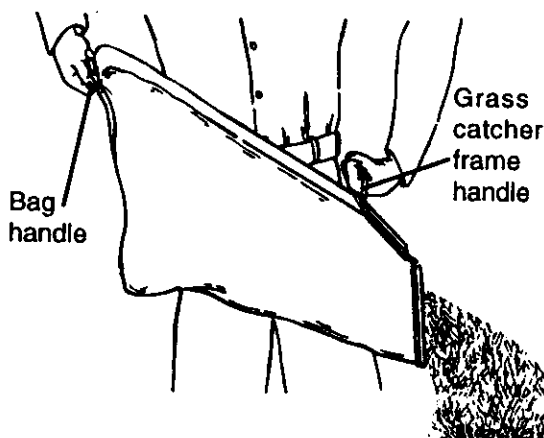

DRIVE CONTROL

- Self-propelling is controlled by holding the operator presence control bar down to the handle and pushing the drive control lever forward until it clicks; then release the drive control lever.
- Forward motion will stop when the operator presence control bar is released. To stop forward motion without stopping engine, release the operator presence control bar slightly until the drive control disengages. Hold operator presence control bar down to handle to continue mowing without self-propelling.
- To keep drive control engaged when turning corners, push down on handle and lift front wheels off ground while turning lawn mower.

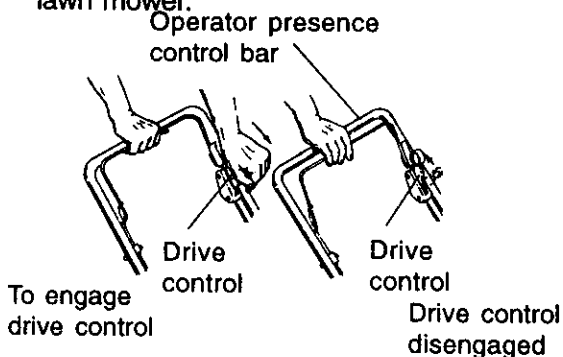

BEFORE STARTING ENGINE

OIL

Your lawn mower is shipped without oil in the engine.

- Be sure mower is level and area around oil fill is clean.
- Remove engine oil cap and fill to the full line on the dipstick.

NOTE: Allow oil to settle down into engine for accurate dipstick reading.

- Engine holds 20 ozs. of oil. For type and grade of oil to use, see "ENGINE" in Maintenance section of this manual.
- Pour oil slowly. Do not over fill.
- Check oil level before each use. Add oil if needed. Fill to full line on dipstick.
- To read proper level, tighten engine oil cap each time.
- Reinstall engine oil cap and tighten.
- Change the oil after every 25 hours of operation or each season. You may need to change the oil more often under dusty, dirty conditions.

ADD GASOLINE

NOTE: Before filling fuel tank, remove and discard the debris plug that is inside the tank.

- Fill fuel tank. Use fresh, clean, regular unleaded gasoline with a minimum of 87 octane (Use of leaded gasoline will increase carbon and lead oxide deposits and reduce valve life). Do not mix oil with gasoline. Purchase fuel in quantities that can be used within 30 days to assure fuel freshness.

WARNING: Experience indicates that alcohol blended fuels (called gasohol or using ethanol or methanol) can attract moisture which leads to separation and formation of acids during storage. Acidic gas can damage the fuel system of an engine while in storage. To avoid engine problems, the fuel system should be emptied before storage of 30 days or longer. Drain the gas tank, start the engine and let it run until the fuel lines and carburetor are empty. Use fresh fuel next season. See Storage Instructions for additional information. Never use engine or carburetor cleaner products in the fuel tank or permanent damage may occur.

CAUTION: Fill to bottom of gas tank filler neck. Do not overfill. Wipe off any spilled oil or fuel. Do not store, spill or use gasoline near an open flame.

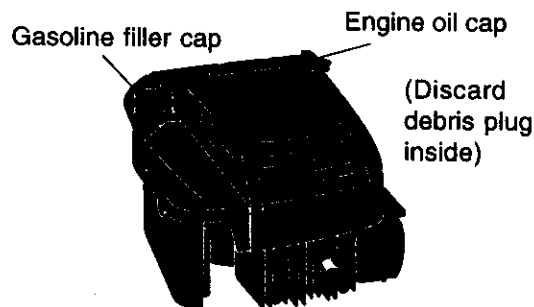

TO START ENGINE

- To start a cold engine, push primer three (3) times before trying to start. Use a firm push. This step is not usually necessary when starting an engine which has already run for a few minutes.
- Move throttle control lever to fast position.
- Hold operator presence control bar down to the handle.
- Turn electric start key clockwise to crank engine.

IMPORTANT: Do not crank engine more than five continuous seconds between each time you try to start. Wait 5 to 10 seconds between each attempt.

- To start engine using the auxiliary starter handle, follow the steps above. Exchange the use of the start key for starter handle. Pull starter handle quickly. Do not allow starter rope to snap back.
- To stop engine, release operator presence control bar.

NOTE: In cooler weather it may be necessary to repeat priming steps. In warmer weather over priming may cause flooding and engine will not start. If you do flood engine wait a few minutes before attempting to start and do not repeat priming steps.

MOWING TIPS

- Under certain conditions, such as very tall grass, it may be necessary to raise the height of cut to reduce pushing effort and to keep from overloading the engine and leaving clumps of grass clippings. It may also be necessary to reduce ground speed and/or run the lawn mower over the area a second time.
- For extremely heavy cutting, reduce the width of cut by overlapping previously cut path and mow slowly.
- For better grass bagging and most cutting conditions, the engine speed should be set in the fast position.
- When using a rear discharge lawn mower in moist, heavy grass, clumps of cut grass may not enter the grass catcher. Reduce ground speed (pushing speed) and/or run the lawn mower over the area a second time.
- If a trail of clippings is left on the right side of a rear discharge mower, mow in a clockwise direction with a small overlap to collect the clippings on the next pass.
- Pores in cloth grass catchers can become filled with dirt and dust with use and catchers will collect less grass. To prevent this, regularly hose catcher off with water and let dry before using.
- Keep top of engine around starter clear and clean of grass clippings and chaff. This will help engine air flow and extend engine life.

MULCHING MOWING TIPS

IMPORTANT: For best performance, keep mower housing free of built-up grass and trash. See "Cleaning" in MAINTENANCE section of this manual.

- The special mulching blade will recut the grass clippings many times and reduce them in size so that as they fall onto the lawn they will disperse into the grass and not be noticed. Also, the mulched grass will biodegrade quickly to provide nutrients for the lawn. Always mulch with your highest engine (blade) speed as this will provide the best recutting action of the blades.
- Avoid cutting your lawn when it is wet. Wet grass tends to form clumps and interferes with the mulching action. The best time to mow your lawn is the early afternoon. At this time the grass has dried and the newly cut area will not be exposed to the direct sun.
- For best results, adjust the lawn mower cutting height so that the lawn mower cuts off only the top one-third of the grass blades. If the lawn is overgrown it will be necessary to raise the height of cut to reduce pushing effort and to keep from overloading the engine and leaving clumps of mulched grass. For extremely heavy mulching, reduce your width of cut by overlapping previously cut path and mow slowly.
- Certain types of grass and grass conditions may require that an area be mulched a second time to completely hide the clippings. When doing a second cut, mow across or perpendicular to the first cut path.
- Change your cutting pattern from week to week. Mow north to south one week then change to east to west the next week. This will help prevent matting and graining of the lawn.

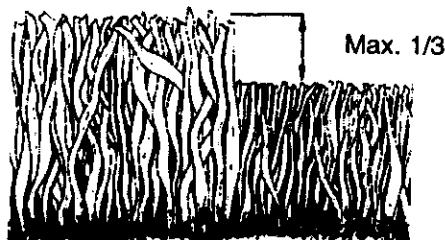

MAINTENANCE

MAINTENANCE SCHEDULE		<div style="display: flex; justify-content: space-between;"> BEFORE EACH USE AFTER EACH USE EVERY 10 HOURS EVERY 25 HOURS OR EVERY SEASON BEFORE STORAGE </div>					SERVICE DATES								
FILL IN DATES AS YOU COMPLETE REGULAR SERVICE															
MOWER	Check for Loose Fasteners	✓					✓								
	Clean/Inspect Grass Catcher (If Equipped)	✓	✓				✓								
	Clean Lawn Mower		✓				✓								
	Clean Under Drive Cover (Power-Propelled Mowers)			✓											
	Check drive belt/pulleys (Power-Propelled Mowers)					✓									
	Check/Sharpen/Replace Blade					✓ ₃									
	Lubrication Chart					✓		✓							
ENGINE	Check Engine Oil Level	✓													
	Change Engine Oil					✓ _{1,2}									
	Clean Air Filter					✓ ₂									
	Inspect Muffler					✓									
	Clean or Replace Spark Plug					✓									
	Replace Air Filter Paper Cartridge					✓ ₂									
	Clean Battery/Recharge (Electric Start Mowers)					✓		✓ ₄							

- 1 - Change more often when operating under a heavy load or in high ambient temperatures.
- 2 - Service more often when operating in dirty or dusty conditions.
- 3 - Replace blades more often when mowing in sandy soil.
- 4 - Charge 48 hours at end of season.

GENERAL RECOMMENDATIONS

The warranty on this lawn mower does not cover items that have been subjected to operator abuse or negligence. To receive full value from the warranty, operator must maintain mower as instructed in this manual.

Some adjustments will need to be made periodically to properly maintain your unit. All adjustments in the Service and Adjustments section of this manual should be checked at least once each season.

- Once a year, replace the spark plug, replace air filter element and check blade for wear. A new spark plug and clean/new air filter element assures proper air-fuel mixture and helps your engine run better and last longer.
- Follow the maintenance schedule in this manual.

BEFORE EACH USE

- Check engine oil level.
- Check for loose fasteners.

LUBRICATION

Keep unit well lubricated (See "LUBRICATION CHART").

LUBRICATION CHART

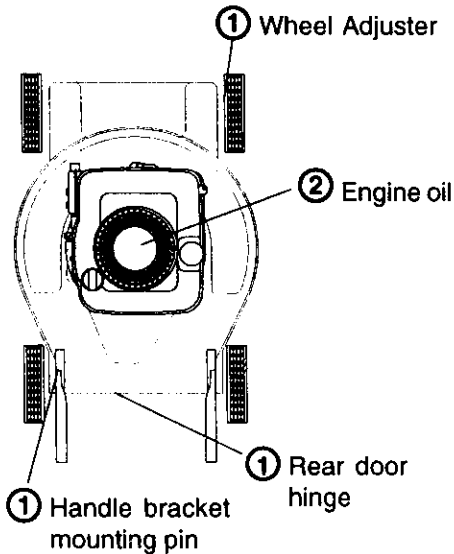

- ① Spay lubricant
- ② Refer to MAINTENANCE "ENGINE" section.

IMPORTANT: Do not oil or grease plastic wheel bearings. Viscous lubricants will attract dust and dirt that will shorten the life of the self lubricating bearings. If you feel they must be lubricated, use only a dry, powdered graphite type lubricant sparingly.

PRODUCT SPECIFICATIONS

SERIAL NUMBER	
DATE OF PURCHASE	
GASOLINE CAPACITY/ TYPE:	1.6 QUARTS
UNLEADED REGULAR	
OIL TYPE (API-SF/SG/SH):	SAE 30 (ABOVE 32°F) SAE 5W-30 (BELOW 32°F)
OIL CAPACITY:	20 OZS.
SPARK PLUG(GAP: .030")	CHAMPIONR J19LM OR J19LM
VALVE CLEARANCE:	INTAKE: .005" - .007" EXHAUST: .007" - .009"
SOLID STATE IGNITION	
AIR GAP:	.010 IN.
BLADE BOLT TORQUE:	35-40 FT. LBS.
<ul style="list-style-type: none"> The model and serial numbers will be found on a decal attached to the rear of the lawn mower housing. Record both serial number and date of purchase in space provided above. 	

LAWN MOWER

Always observe safety rules when performing any maintenance.

TIRES

- Keep tires free of gasoline, oil, or insect control chemicals which can harm rubber.
- Avoid stumps, stones, deep ruts, sharp objects and other hazards that may cause tire damage.

BLADE CARE

For best results, mower blade must be kept sharp. Replace bent or damaged blades.

TO REMOVE BLADE

- Disconnect spark plug wire from spark plug and place wire where it cannot come in contact with spark plug.
- Turn lawn mower on its side. Make sure air filter and carburetor are up.
- Use a wood block between blade and mower housing to prevent blade from turning when removing blade bolt.
- Protect your hands with gloves and/or wrap blade with heavy cloth.
- Remove blade bolt by turning counter-clockwise.
- Remove blade and attaching hardware (bolt, lock washer and hardened washer).

NOTE: Remove the blade adapter and check the key inside hub of blade adapter. The key must be in good condition to work properly. Replace adapter if damaged.

TO REPLACE BLADE

- Position the blade adapter on the engine crankshaft. Be sure key in adapter and crankshaft keyway are aligned.
- Position blade on the blade adapter aligning the two (2) holes in the blade with the raised lugs on the adapter.
- Be sure the trailing edge of blade (opposite sharp edge) is up toward the engine.
- Install the blade bolt with the lock washer and hardened washer into blade adapter and crankshaft.
- Use block of wood between blade and lawn mower housing and tighten the blade bolt, turning clockwise.
- The recommended tightening torque is 35-40 ft. lbs.

IMPORTANT: Blade bolt is grade 8 heat treated.

TO SHARPEN BLADE

NOTE: We do not recommend sharpening blade - but if you do, be sure the blade is balanced.

Care should be taken to keep the blade balanced. An unbalanced blade will cause eventual damage to lawn mower or engine.

- The blade can be sharpened with a file or on a grinding wheel. Do not attempt to sharpen while on the mower.
- To check blade balance, drive a nail into a beam or wall. Leave about one inch of the straight nail exposed. Place center hole of blade over the head of the nail. If blade is balanced, it should remain in a horizontal position. If either end of the blade moves downward, sharpen the heavy end until the blade is balanced.

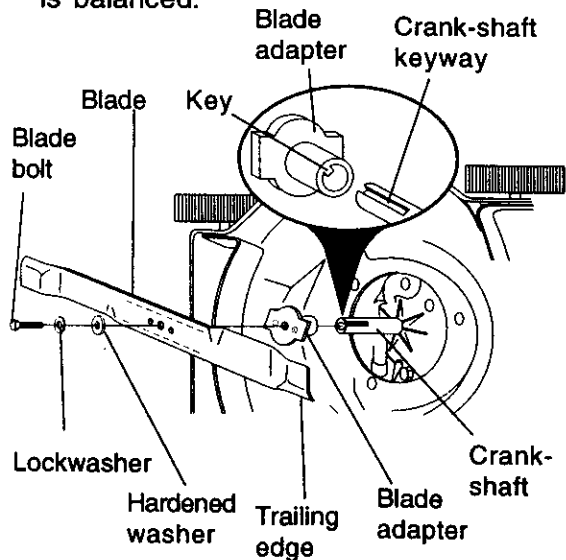

GRASS CATCHER

- The grass catcher may be hosed with water, but must be dry when used.
- Check your grass catcher often for damage or deterioration. Through normal use it will wear. If catcher needs replacing, replace only with a manufacturer approved replacement catcher. Give the lawn mower model number when ordering.

DRIVE WHEELS

Check front drive wheels each time before you mow to be sure they move freely.

The wheels not turning freely means trash, grass cuttings, etc. are in the drive

wheel area and must be cleaned to free drive wheels.

If necessary to clean the drive wheels, check both front wheels.

- Remove hubcaps, hairpin cotters and washers.
- Remove wheels from wheel adjusters.
- Remove any trash or grass cuttings from inside the dust cover, pinion and/or drive wheel gear teeth.
- Put wheels back in place.
- If after cleaning, the drive wheels do not turn freely, contact your nearest authorized service center.

GEAR CASE

- To keep your drive system working properly, the gear case and area around the drive should be kept clean and free of trash build-up. Clean under the drive cover twice a season.
- The gear case is filled with lubricant to the proper level at the factory. The only time the lubricant needs attention is if service has been performed on the gear case.
- If lubricant is required, use only Texaco Starplex Premium 1 Grease, Part No. 750369. Do not substitute.

ENGINE

LUBRICATION

Use only high quality detergent oil rated with API service classification SF, SG or SH. Select the oil's SAE viscosity grade according to your expected operating temperature.

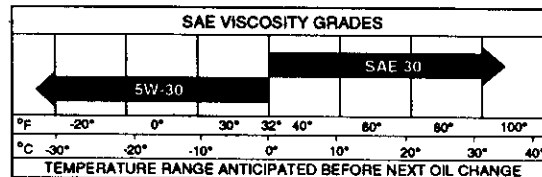

NOTE: Although multi-viscosity oils (5W30, 10W30 etc.) improve starting in cold weather, these multi-viscosity oils will result in increased oil consumption when used above 32°F. Check your engine oil level more frequently to avoid possible engine damage from running low on oil.

Change the oil after every 25 hours of operation or at least once a year if the lawn mower is not used for 25 hours in one year.

Check the crankcase oil level before starting the engine and after each five (5) hours of continuous use. Tighten oil plug securely each time you check the oil level.

TO CHANGE ENGINE OIL

NOTE: Before tipping lawn mower to drain oil, drain fuel tank by running engine until fuel tank is empty.

- Disconnect spark plug wire from spark plug and place wire where it cannot come in contact with spark plug.
- Remove engine oil cap; lay aside on a clean surface.
- Tip lawn mower on its side as shown and drain oil into a suitable container. Rock lawn mower back and forth to remove any oil trapped inside of engine.
- Wipe off any spilled oil on lawn mower and on side of engine.
- Fill engine with oil. Fill only to the "FULL" line on the dipstick. DO NOT overfill.
- Replace engine oil cap.
- Reconnect spark plug wire to spark plug.

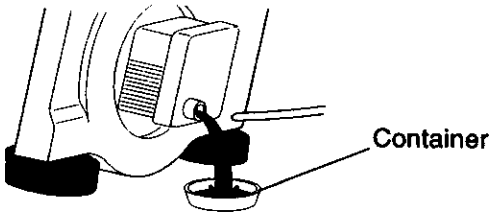

AIR FILTER

Your engine will not run properly and may be damaged by using a dirty air filter. Replace the air filter every year, more often if you mow in very dusty, dirty conditions.

TO CLEAN AIR FILTER

- Loosen screw and tilt cover to remove.
- Carefully remove cartridge.
- Clean by gently tapping on a flat surface. If very dirty, replace cartridge.

CAUTION: Petroleum solvents, such as kerosene, are not to be used to clean cartridge. They may cause deterioration of the cartridge. Do not oil cartridge. Do not use pressurized air to clean or dry cartridge.

- Install cartridge, then replace cover making sure the tabs are aligned with the slots in the back plate. Fasten screw securely.

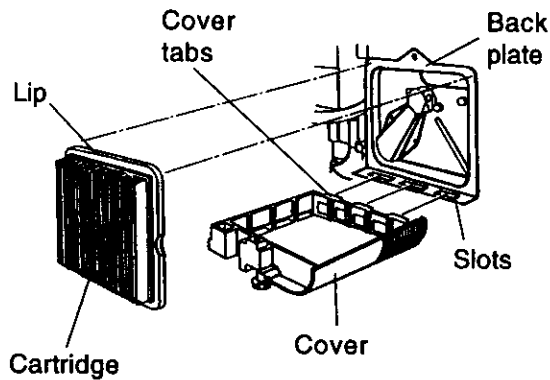

MUFFLER

Inspect and replace corroded muffler as it could create a fire hazard and/or damage.

SPARK PLUG

Change your spark plug each year to make your engine start easier and run better. Set spark plug gap at .030 inch.

CLEANING

IMPORTANT: For best performance, keep mower housing free of built-up grass and trash. Clean the underside of your mower after each use.

CAUTION: Disconnect spark plug wire from spark plug and place wire where it cannot come in contact with the spark plug.

- Turn lawn mower on its side. Make sure air filter and carburetor are up. Clean the underside of your lawn mower by scraping to remove buildup of grass and trash.
- Clean engine often to keep trash from accumulating. A clogged engine runs hotter and shortens engine life.
- Keep finished surfaces and wheels free of all gasoline, oil, etc.
- We do not recommend using a garden hose to clean lawn mower unless the electrical system, muffler, air filter and carburetor are covered to keep water out. Water in engine can result in shortened engine life.

CLEAN UNDER DRIVE COVER

Clean under drive cover at least twice a season. Scrape underside of cover with putty knife or similar tool to remove any buildup of trash or grass on underside of drive cover.

SERVICE AND ADJUSTMENTS

CAUTION: Before performing any service or adjustments.

- Release control bar and stop engine.
- Make sure the blade and all moving parts have completely stopped.
- Disconnect spark plug wire from spark plug and place where it cannot come in contact with plug.

LAWN MOWER

TO ADJUST CUTTING HEIGHT

See "TO ADJUST CUTTING HEIGHT" in the Operation section of this manual.

REAR DEFLECTOR

The rear deflector, attached between the rear wheels of your lawn mower, is provided to minimize the possibility that objects will be thrown out the rear of the lawn mower into the operator's mowing position. If the rear deflector becomes damaged, it should be replaced.

TO REMOVE/REPLACE DRIVE BELT

- Remove drive cover. Remove belt by pushing down on gear case pulley and rolling belt off it.
- Turn lawn mower on its side with carburetor and fuel cap up.
- Remove blade.
- Remove debris shield.
- Remove belt from engine pulley on crankshaft.
- Install new belt by reversing above steps.
- Always use factory approved belt to assure fit and long life.

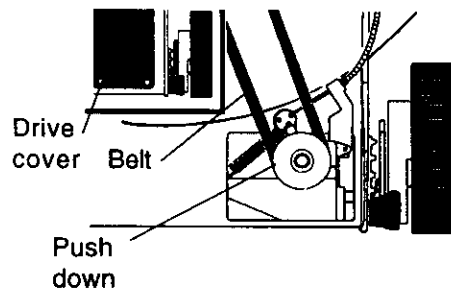

TO ADJUST HANDLE

The handle can be mounted in a high or low position. The mounting holes in the bottom of lower handle are off center for raising or lowering the handle.

- Remove upper handle and all parts attached to lower handle.
- Remove hairpin cotters from lower handle bracket mounting pin.
- Squeeze lower handle in to remove it from mounting pins.
- Turn lower handle over to raise or lower handle.
- Squeeze lower handle in and position holes onto mounting pins on handle bracket.
- Reassemble upper handle and all parts removed from lower handle.

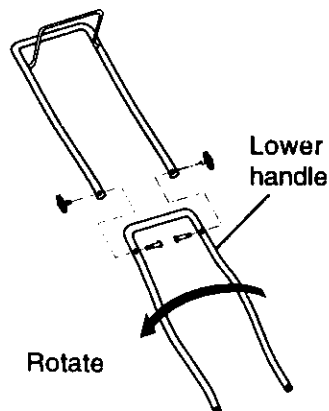
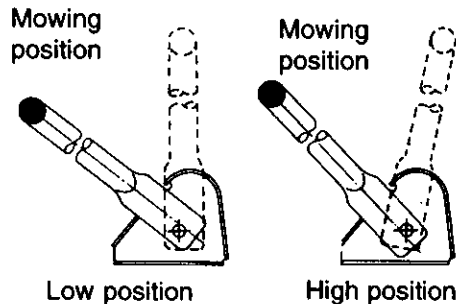

TO ASSEMBLE GRASS CATCHER

- Put grass catcher frame into grass bag with rigid part of bag on the bottom. Make sure the frame handle is outside of the bag top.

- Slip vinyl bindings over frame.

NOTE: If vinyl bindings are too stiff, hold them in warm water for a few minutes. If bag gets wet, let it dry before using.

CAUTION: Do not run your lawn mower without clipping deflector or approved grass catcher in place. Never attempt to operate the lawn mower with the rear door removed or propped open.

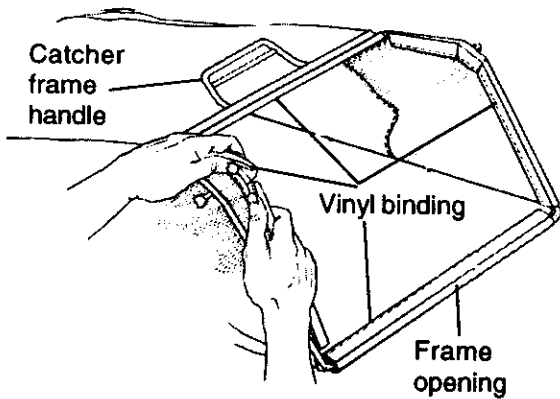

ENGINE

ENGINE SPEED

Your engine speed has been factory set. Do not attempt to increase engine speed or it may result in personal injury. If you believe that the engine is running too fast or too slow, take your lawn mower to an authorized service center for repair and adjustment.

CARBURETOR

Your carburetor is not adjustable. If your engine does not operate properly due to suspected carburetor problems, take your lawn mower to an authorized service center for repair and/or adjustment.

IMPORTANT: Never tamper with the engine governor, which is factory set for proper engine speed. Overspeeding the engine above the factory high speed setting can be dangerous. If you think the engine-governed high speed needs adjusting, contact your nearest authorized service center, which has proper equipment and experience to make any necessary adjustments.

STORAGE

Immediately prepare your lawn mower for storage at the end of the season or if the unit will not be used for 30 days or more.

LAWN MOWER

When lawn mower is to be stored for a period of time, clean it thoroughly, remove all dirt, grease, leaves, etc. Store in a clean, dry area.

- Clean entire lawn mower (See "CLEANING" in the Maintenance section of this manual).
- Lubricate as shown in the Maintenance section of this manual.
- Be sure that all nuts, bolts, screws, and pins are securely fastened. Inspect moving parts for damage, breakage and wear. Replace if necessary.
- Touch up all rusted or chipped paint surfaces; sand lightly before painting.

HANDLE

You can fold your lawn mower handle for storage.

- Squeeze the bottom ends of the lower handle toward each other until the lower handle clears the handle bracket, then move handle forward.
- Loosen upper handle mounting bolts enough to allow upper handle to be folded back.

IMPORTANT: When folding the handle for storage or transportation, be sure to fold the handle as shown or you may damage the control cables.

- When setting up your handle from the storage position, the lower handle will automatically lock into the mowing position.

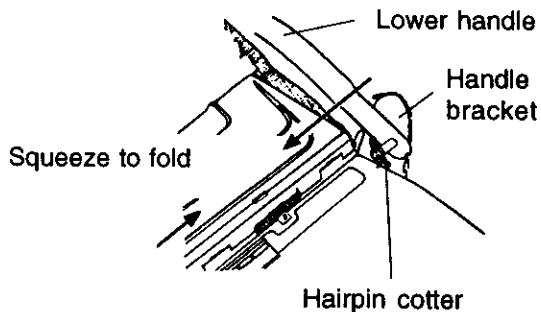

Operator presence control bar

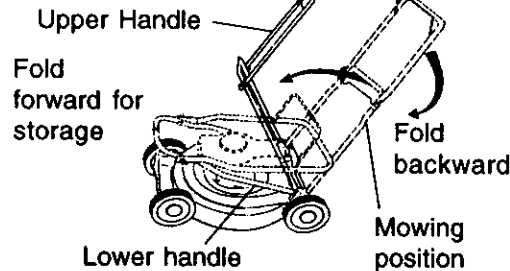

ENGINE

FUEL SYSTEM

IMPORTANT: It is important to prevent gum deposits from forming in essential fuel system parts such as carburetor, fuel filter, fuel hose, or tank during storage. Also, experience indicates that alcohol blended fuels (called gasohol or using ethanol or methanol) can attract moisture which leads to separation and formation of acids during storage. Acidic gas can damage the fuel system of an engine while in storage.

- Drain the fuel tank.
- Start the engine and let it run until the fuel lines and carburetor are empty.
- Never use engine or carburetor cleaner products in the fuel tank or permanent damage may occur.
- Use fresh fuel next season.

NOTE: Fuel stabilizer is an acceptable alternative in minimizing the formation of fuel gum deposits during storage. Add stabilizer to gasoline in fuel tank or storage container. Always follow the mix ratio found on stabilizer container. Run engine at least 10 minutes after adding stabilizer to allow the stabilizer to reach the carburetor. Do not drain the gas tank and carburetor if using fuel stabilizer.

ENGINE OIL

Drain oil (with engine warm) and replace with clean engine oil. (See "ENGINE" in the Maintenance section of this manual).

CYLINDER

- Remove spark plug.
- Pour one ounce (29 ml) of oil through spark plug hole into cylinder.
- Pull starter handle slowly a few times to distribute oil.
- Replace with new spark plug.

BATTERY

Disconnect the battery from the engine connector and charge battery 48 hours.

OTHER

- Do not store gasoline from one season to another.
- Replace your gasoline can if your can starts to rust. Rust and/or dirt in your gasoline will cause problems.
- If possible, store your unit indoors and cover it to give protection from dust and dirt.

- Cover your unit with a suitable protective cover that does not retain moisture. Do not use plastic. Plastic cannot breathe which allows condensation to form and will cause your unit to rust.

IMPORTANT: Never cover mower while engine and exhaust areas are still warm.

CAUTION: Never store the lawn mower with gasoline in the tank inside a building where fumes may reach an open flame or spark. Allow the engine to cool before storing in any enclosure.

TROUBLESHOOTING CHART

PROBLEM	CAUSE	CORRECTION
Does not start	<ol style="list-style-type: none"> 1. Dirty air filter. 2. Out of fuel. 3. Stale fuel. 4. Water in fuel. 5. Spark plug wire is disconnected. 6. Bad spark plug. 7. Loose blade or broken blade adapter. 8. Control bar in released position. 9. Control bar defective. 10. Weak battery 11. Disconnected battery connector. 	<ol style="list-style-type: none"> 1. Clean/replace air filter. 2. Fill fuel tank. 3. Drain tank and refill with fresh clean fuel. 4. Drain fuel tank and carburetor and refill tank with fresh gasoline. 5. Connect wire to plug. 6. Replace spark plug. 7. Tighten blade bolt or replace blade adapter. 8. Depress control bar to handle. 9. Replace control bar. 10. Charge battery. 11. Connect battery to engine.
Loss of power	<ol style="list-style-type: none"> 1. Rear of lawn mower housing or cutting blade dragging in heavy grass. 2. Cutting too much grass. 3. Dirty air filter. 4. Buildup of grass, leaves, and trash under mower. 5. Too much oil in engine. 6. Walking speed too fast. 	<ol style="list-style-type: none"> 1. Set to "Higher Cut" position. 2. Set to "Higher Cut" position. 3. Clean/replace air filter. 4. Clean underside of mower housing. 5. Check oil level. 6. Cut at slower walking speed.
Poor cut – uneven	<ol style="list-style-type: none"> 1. Worn, bent or loose blade. 2. Wheel heights uneven. 3. Low engine speed 4. Buildup of grass, leaves and trash under mower. 	<ol style="list-style-type: none"> 1. Replace blade. Tighten blade bolt. 2. Set all wheels at same height 3. Contact an authorized center/department 4. Clean underside of mower housing.

TROUBLESHOOTING CHART

PROBLEM	CAUSE	CORRECTION
Excessive vibration	<ol style="list-style-type: none"> 1. Worn, bent or loose blade. 2. Bent engine crankshaft. 	<ol style="list-style-type: none"> 1. Replace blade. Tighten blade bolt. 2. Contact an authorized service center.
Starter rope hard to pull	<ol style="list-style-type: none"> 1. Engine flywheel brake is on when control bar is released. 2. Bent engine crankshaft. 3. Blade adapter broken. 4. Blade dragging in grass. 	<ol style="list-style-type: none"> 1. Depress control bar to upper handle before pulling starter rope. 2. Contact an authorized service center. 3. Replace blade adapter. 4. Move lawn mower to cut grass or to hard surface.
Loss of drive	<ol style="list-style-type: none"> 1. Drive wheels not turning with drive control engaged. 2. Belt not driving 	<ol style="list-style-type: none"> 1. Adjust or replace drive control cable. 2. Put belt on pulleys or replace belts if broken.
Grass catcher not filling (if so equipped)	<ol style="list-style-type: none"> 1. Cutting height too low. 2. Lift on blade worn off. 3. Catcher not venting air. 4. Low engine speed. 	<ol style="list-style-type: none"> 1. Raise cutting height. 2. Replace blade. 3. Clean grass catcher. 4. Set engine speed control in fast position
Hard to push	<ol style="list-style-type: none"> 1. Grass is too high or wheel height is too low. 2. Rear of lawn mower housing or blade dragging in grass. 3. Grass catcher too full. 4. Handle height position not right for you. 	<ol style="list-style-type: none"> 1. Raise cutting height. 2. Raise rear of lawn mower housing one (1) setting higher. 3. Empty grass catcher. 4. Adjust handle height to suit.

REPAIR PARTS

ROTARY LAWN MOWER -- MODEL NO. 917.377170

BATTERY

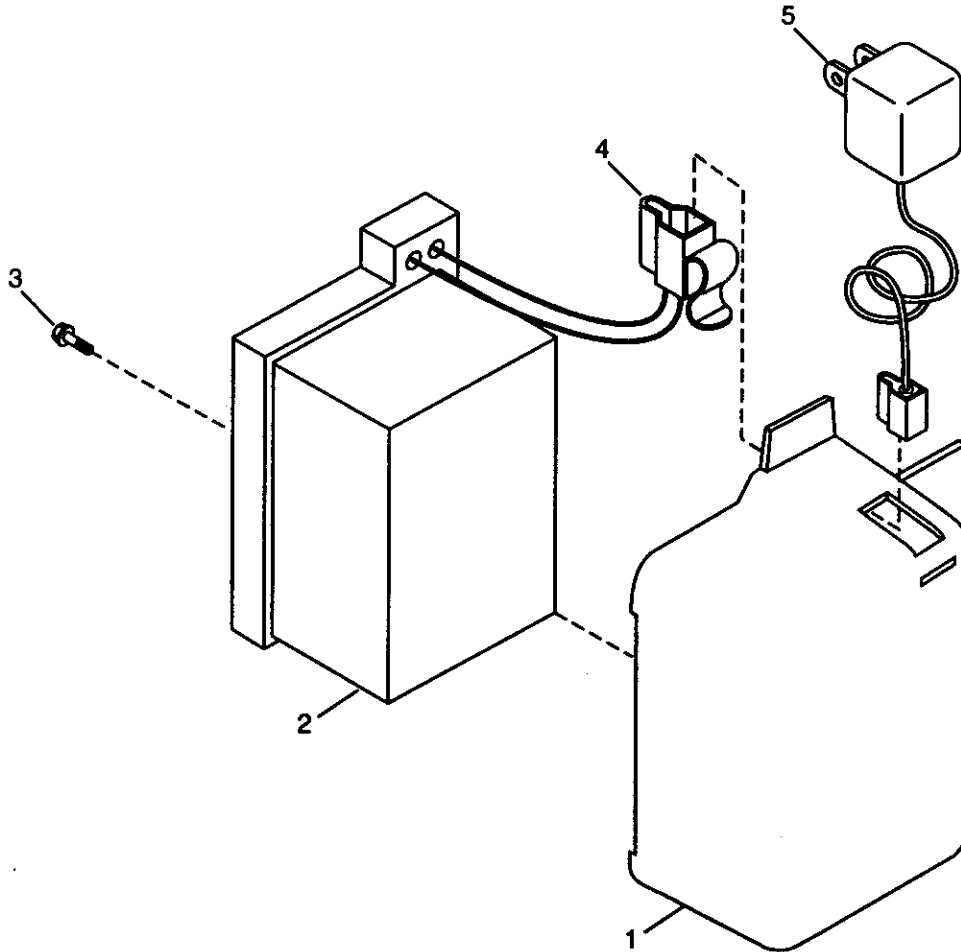

KEY NO.	PART NO.	DESCRIPTION
1	157553	Battery Bracket
2	750909	Battery
3	17411312	Hex Washer Head Screw 13 x .750
4	86353	Connector Mounting Clip
5	111549X	Battery Charger

REPAIR PARTS

ROTARY LAWN MOWER -- MODEL NO. 917.377170

GEAR CASE ASSEMBLY PART NUMBER 702511

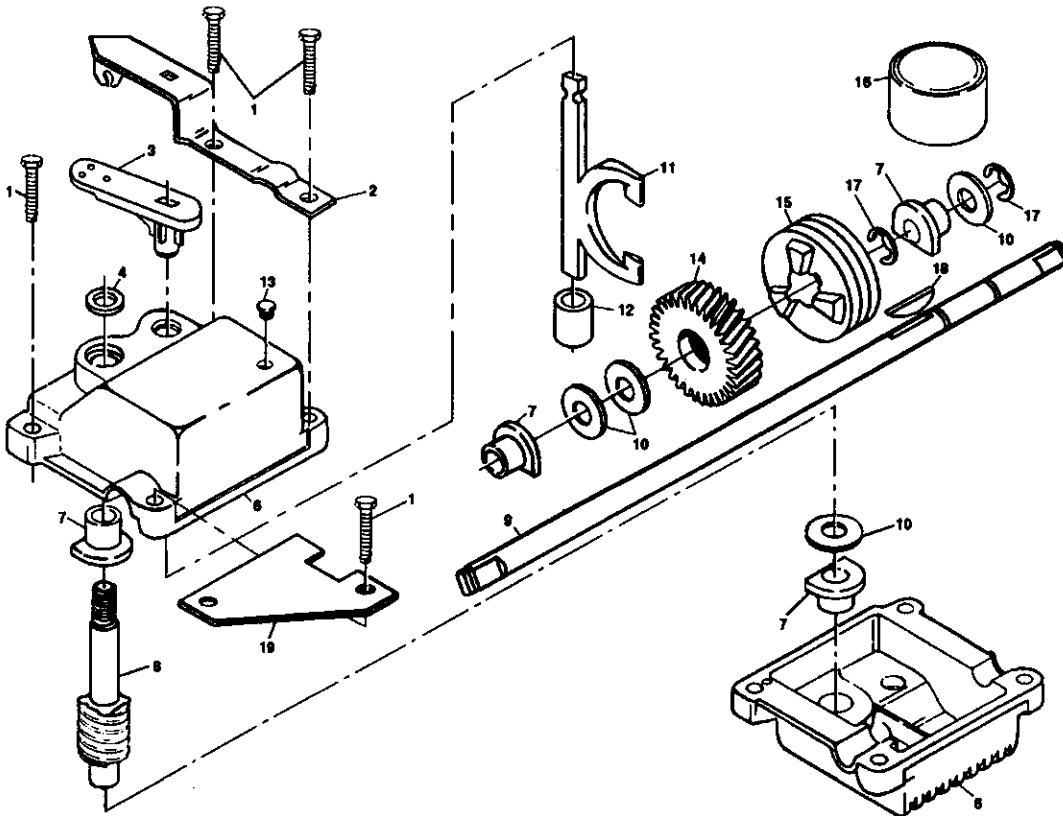

KEY NO.	PART NO.	DESCRIPTION	KEY NO.	PART NO.	DESCRIPTION
1	17490416	Tapping Screw 1/4-20 x 1-1/4	10	57079	Hardened Washer
2	137055X004	Engagement Bracket	11	131484	Clutch Yoke
3	137053	Shifter	12	700343	Bushing
4	57072	Seal	13	86447	Plug
6	48373	Gear Case Halves Kit (Includes Key Nos. 4, and 7)	14	137050	Helical Gear
7	77881	Bearing	15	750436X	Clutch Jaw
8	137051	Worm Shaft	16	750369	Grease
9	137074	Drive Shaft	17	12000003	E-Ring
			18	850848	Hi-Pro Key
			19	81585X004	Spring Bracket

NOTE: All component dimensions given in U.S. inches. 1 inch = 25.4 mm

ROTARY LAWN MOWER MODEL NUMBER 917.377170

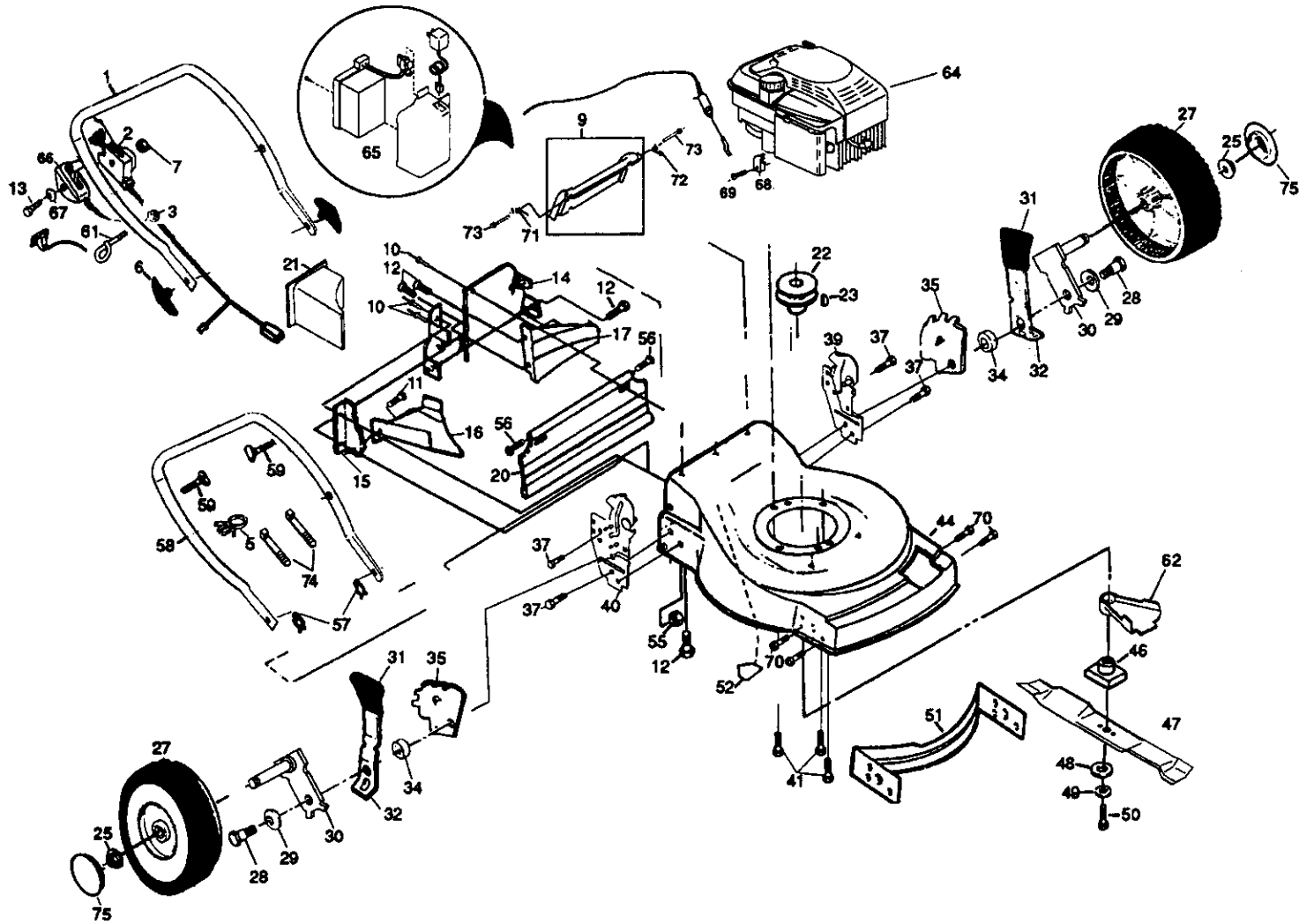

ROTARY LAWN MOWER MODEL NUMBER 917.377170

83

KEY NO.	PART NO.	DESCRIPTION	KEY NO.	PART NO.	DESCRIPTION
1	165452X479	Upper Handle	44	172833	Lawn Mower Housing (Incl. Key #14,15, 17, 51 & 52)
2	171595	Engine zone control cable	46	851514	Blade Adapter
3	63601	Nylon LockNut	47	141114	Blade 22"
6	136376	Handle Knob	48	851074	Hardened Washer
7	63601	Locknut 1/4-20	49	850263	Helical Washer 3/8-24 x 1-3/8 Grd. 8
9	170947	Rear Door Kit	50	851084	Hex Head Machine Screw 3/8-24 x 1-3/8 Grd. 8
10	128415	Pop Rivet	51	170031	Front Baffle
11	150050	Self Tapping Screw #10-24	52	85463	Danger Decal
12	STD512505	Hex Tapping Screw 1/4-20 x 1/2	55	751592	Locknut 3/8-16
13	701650	Hex Washer Head Screw 1/4-20 x 2-1/8	56	88652	Hinge Screw
14	156374X479	Back Plate	57	51793	Hairpin Cotter
15	700365X479	Side Baffle	58	157081X479	Lower Handle
16	133190X479	Discharge Baffle	59	131959	Handle Bolt
17	140661X479	Rear Baffle	61	132001	Rope Guide
20	140540	Rear Skirt	62	134612	Debris Shield
21	150425	Mulcher Plug	64	-----	Engine - (See Breakdown) Briggs & Stratton Model 12H807-2632-B1
22	84596	Engine Pulley	65	-----	See Battery Repair Parts Page
23	87677	Hi-Pro Key #505	66	700417	Throttle control
25	83923	Nut	67	85723	Washer
27	151158	Wheel & Tire Assembly	68	111190X	Cable Clamp
28	142748	Shoulder Bolt 3/8-16	69	83816	Screw
29	62335	Belleville Washer	70	17600406	Screw Hex Serrated 1/4 x 20
30	145935X004	Axle Arm Assembly	71	170938	Spring LH
31	701037	Selector Knob	72	170939	Spring RH
32	700331X004	Selector Spring	73	165912	Bolt
34	146630	Spacer	--	161058	Warning Decal (Not Shown)
35	700325X007	Wheel Adjusting Bracket	74	66426	Wire tie
37	150078	Thread Cutting Screw 5/16-18 x 3/4	75	77400	Hub Cap
39	170943X479	Handle Bracket Assembly (Left)	--	170974	Owner's Manual (English/Spanish)
40	170942X479	Handle Bracket Assembly (Right)			
41	150406	Hex Head Thread Rolling Screw 3/8-16 x 1-1/8			
			Available accessories not included with lawn mower:		
			71	33000	SAE 30W Oil (20 oz.)
				D/9833313	Chute Deflector

ROTARY LAWN MOWER MODEL NUMBER 917.377170

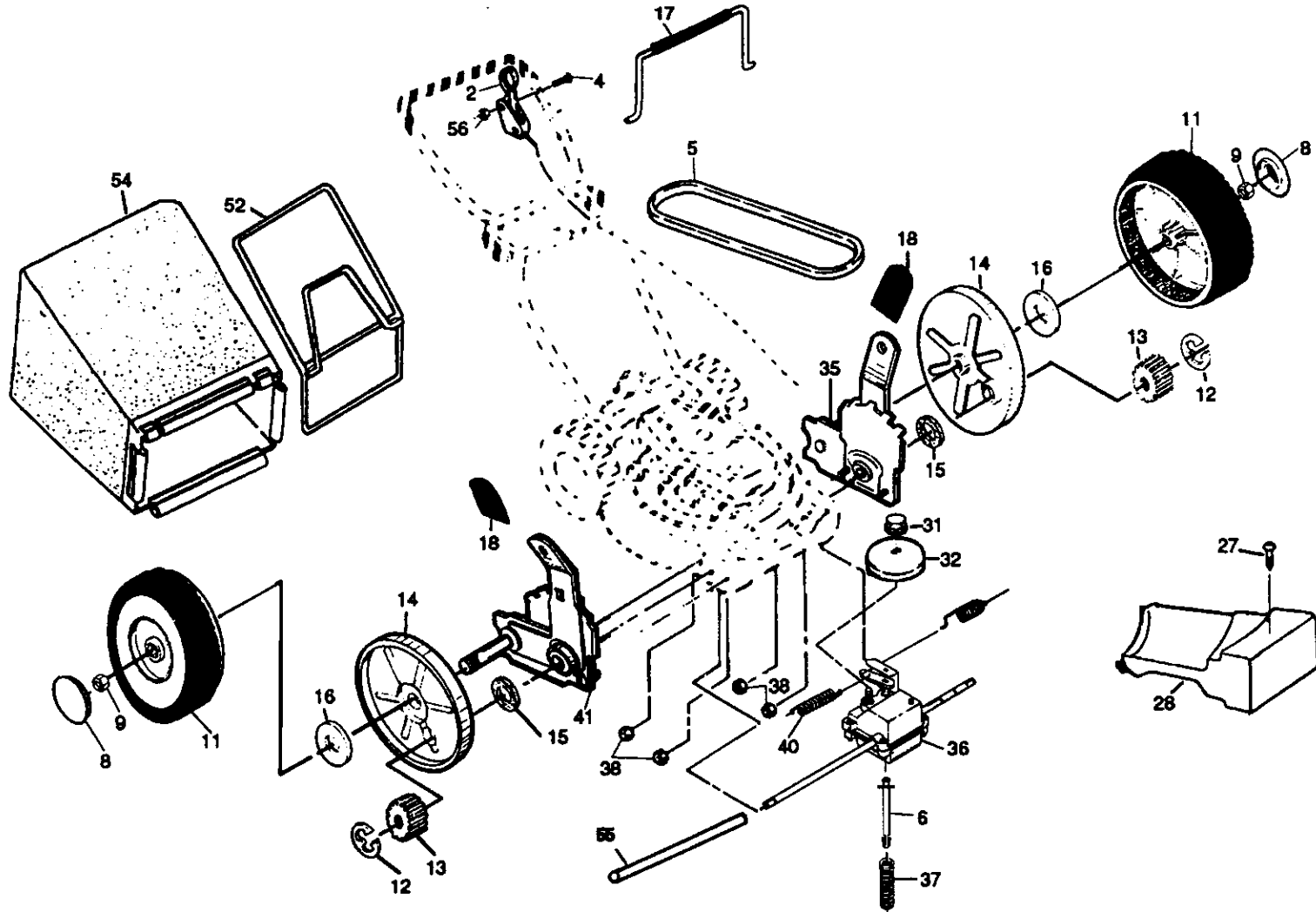

ROTARY LAWN MOWER MODEL NUMBER 917.377170

KEY NO.	PART NO.	DESCRIPTION	KEY NO.	PART NO.	DESCRIPTION
2	145755	Drive Control	28	154990	Drive Cover
4	158755	Hex Washer Head Screw 1/4-20 x 2-1/8	31	132010	Hex Flange Nut
5	146527	V-Belt	32	137052	Drive Pulley
6	150495	Spring Retainer	35	151521	Wheel Adjuster Assembly (Left)
8	77400	Hubcap	36	702511	Gear Case Assembly
9	145212	Hex Nut	37	137090	Spring
11	151156	Wheel & Tire Assembly	38	63601	Nut
12	12000058	E-Ring	40	75192	Spring
13	137054	Pinion	41	151520	Wheel Adjuster Assembly (Right)
14	88080	Dust Cover	52	169931	Catcher Frame
15	88118	Felt Washer	54	169932	Grassbag
16	67725	Washer 1/2 x 1-1/2 x .134	55	86012	Driveshaft Cover
17	145793	Control Bar	56	751152	Nut
18	701037	Selector Knob			
27	143603	Hex Washer Head Screw #10-24 x 3/4			

**BRIGGS & STRATTON
4-CYCLE ENGINE**

**MODEL NO. 12H807
TYPE NO. 2632-B1**

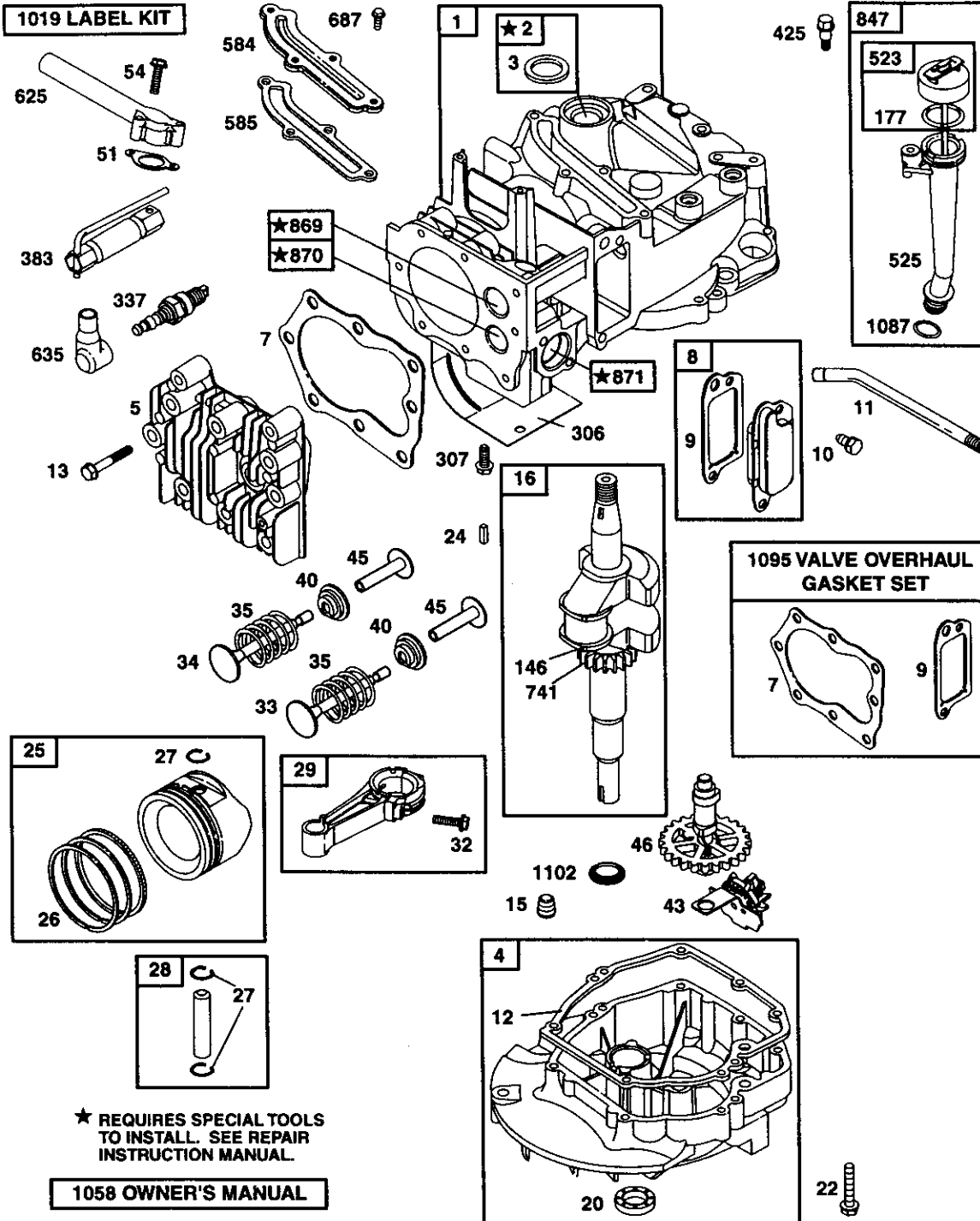

**BRIGGS & STRATTON
4-CYCLE ENGINE**

**MODEL NO. 12H807
TYPE NO. 2632-B1**

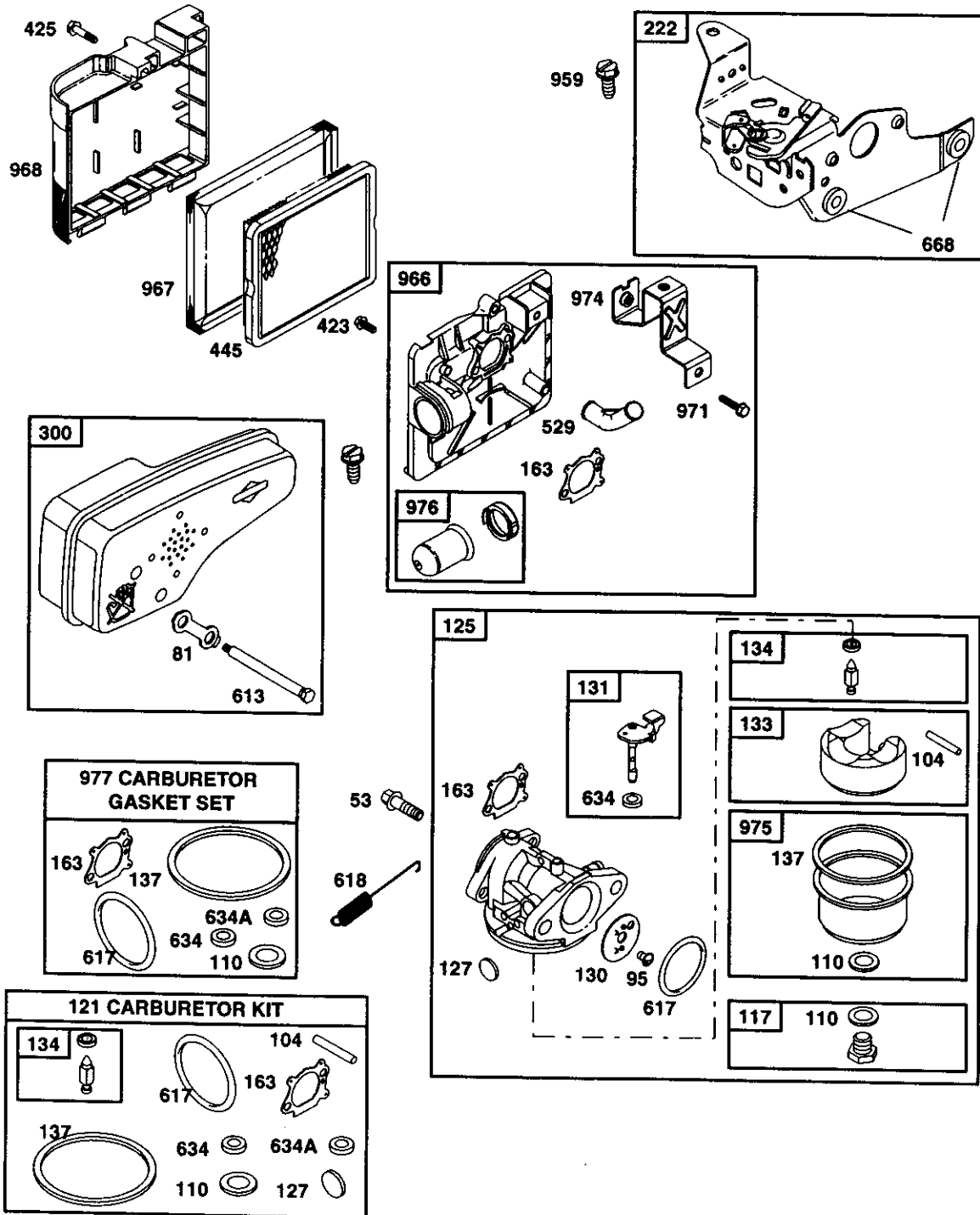

**BRIGGS & STRATTON
4-CYCLE ENGINE**

**MODEL NO. 12H807
TYPE NO. 2632-B1**

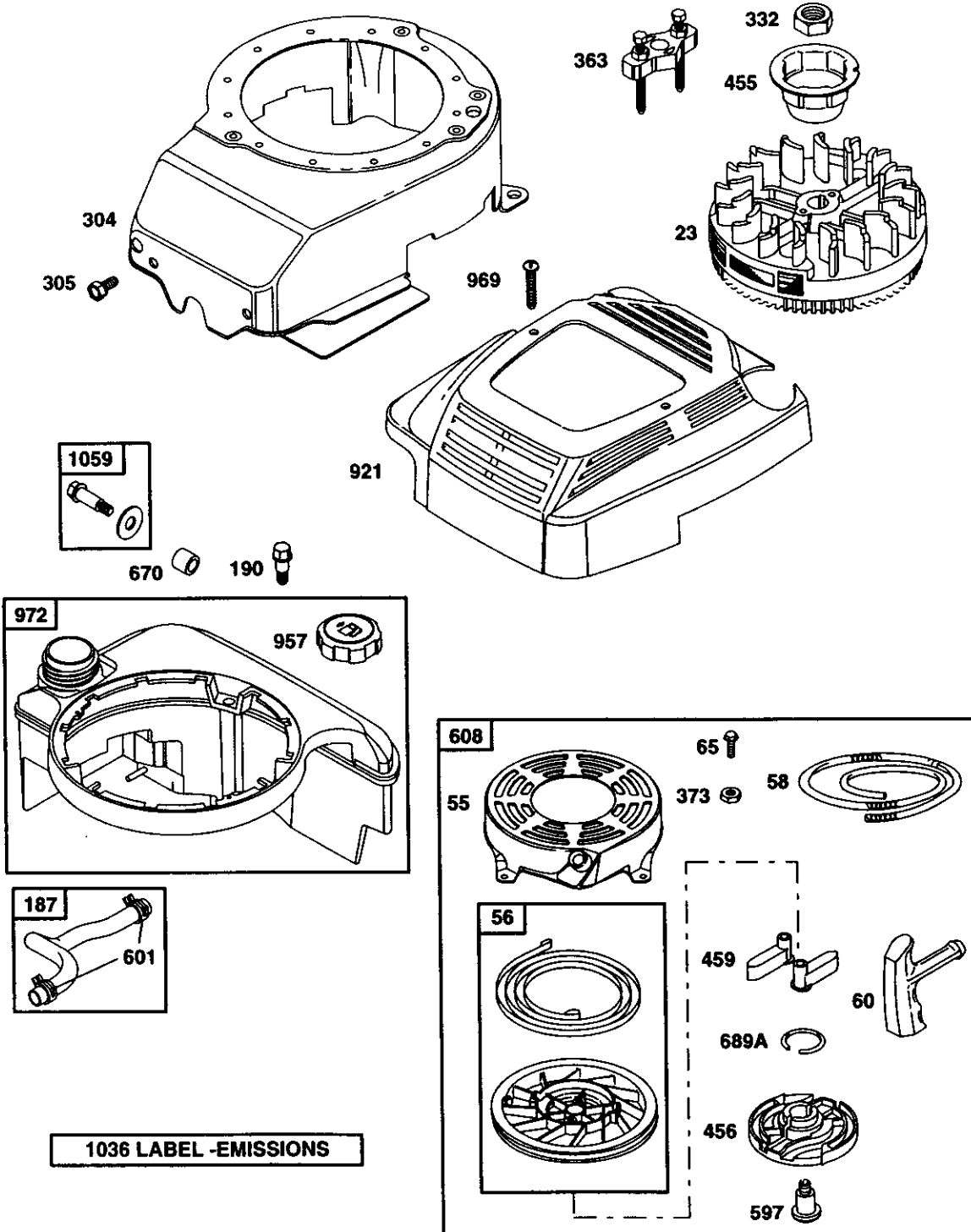

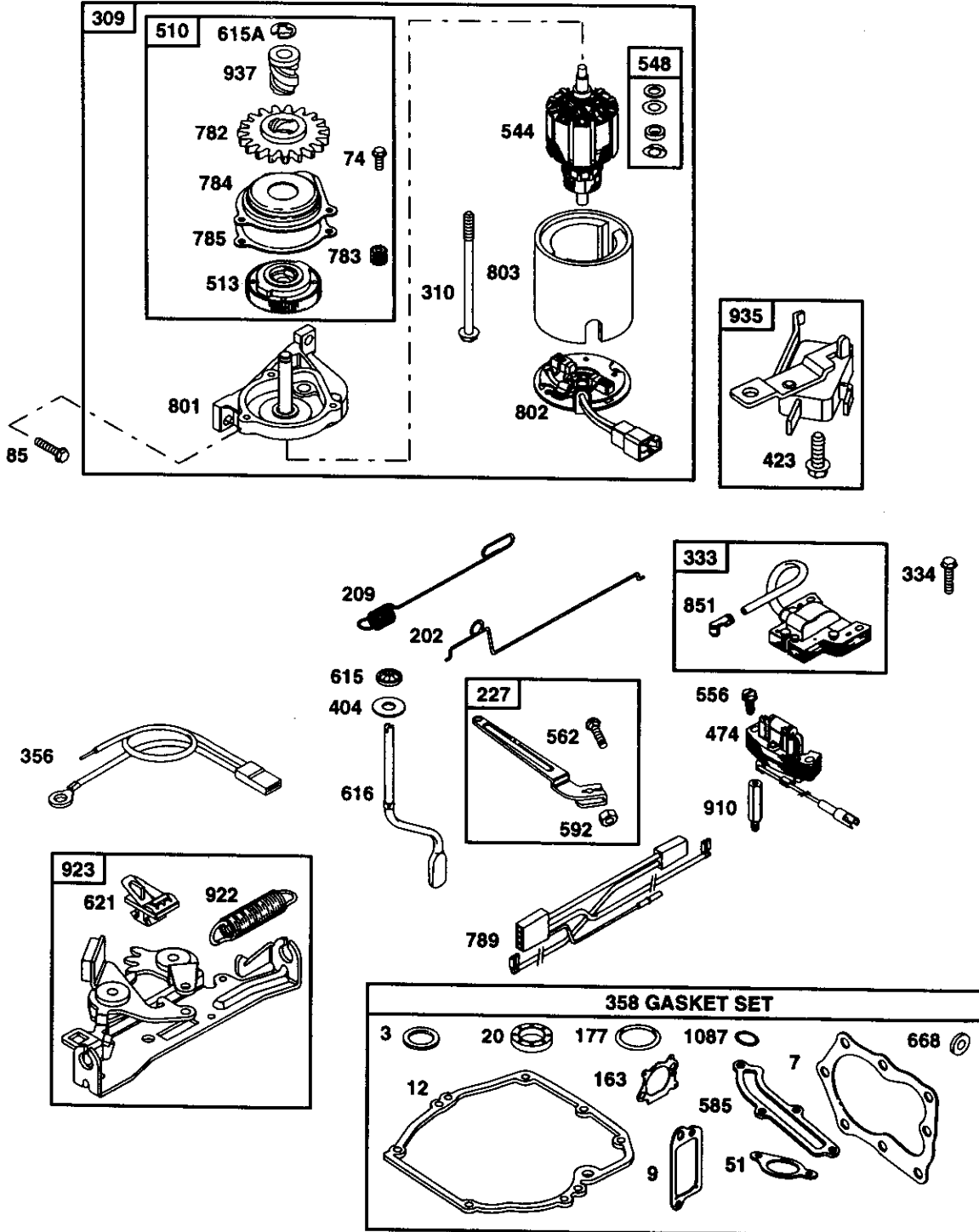

**BRIGGS & STRATTON
4-CYCLE ENGINE**

**MODEL NO. 12H807
TYPE NO. 2632-B1**

KEY PART NO.	PART NO.	DESCRIPTION	KEY PART NO.	PART NO.	DESCRIPTION
1	493260	Cylinder Assembly	65	94686	Screw (Rewind Starter Housing)
2	293708	Bushing/Seal Kit	74	690345	Screw-Hex.
3	299819	★ Seal-Oil	81	223664	Lock-Muffler Screw
4	493279	Sump-Engine	85	94974	Screw-Hex.
5	214368	Head-Cylinder	95	94098	Screw (Throttle Valve)
7	272916	★+ Gasket-Cylinder Head	104	231371	● Pin-Float Hinge
8	495786	Breather Assembly	110	— — —	●◆ Washer (Sold in Kit Only)
9	272481	★+ Gasket-Breather	117	494870	Jet-Main
10	691125	Screw (Breather Assembly)	121	498260	Carburetor Kit
11	691781	Tube-Breather	125	498170	Carburetor
12	272198	★ Gasket-Crankcase	127	— — —	● Plug-Welch (Sold in Kit Only)
13	94547	Screw (Cylinder Head)	130	224908	Valve-Throttle
15	94880	Plug-Oil Drain	131	493267	Shaft-Throttle
16	498565	Crankshaft	133	398187	Float-Carburetor
20	399781	★ Seal-Oil	134	398188	● Valve-Needle (Includes Seat)
22	94220	Screw (Engine Sump)	137	— — —	●◆ Gasket-Float Bowl (Sold in Kit Only)
	94612	Screw (One Used in Hole Nearest Breather)	146	94388	Key-Timing
23	492175	Flywheel	163	272653	★◆ Gasket-Air Cleaner
24	222698	Key-Flywheel	177	280393	★ Seal-O-Ring
25	499429	Piston Assembly (Standard)	187	492791	Line-Fuel (Molded)
	499430	Piston Assy. (.010" O.S.)	190	94511	Screw (Fuel Tank)
	499431	Piston Assy. (.020" O.S.)	202	262579	Link-Mechanical Governor
	499432	Piston Assy. (.030" O.S.)	209	263044	Spring-Governor
26	499425	Ring Set (Standard)	222	497203	Bracket-Control
	499426	Ring Set (.010" O.S.)	227	492349	Lever-Governor
	499427	Ring Set (.020" O.S.)	258	94512	Screw (Brake)
	499428	Ring Set (.030" O.S.)	287	94511	Screw (Oil Fill Tube)
27	263190	Lock-Piston Pin	300	497838	Muffler-Exhaust
28	499423	Pin-Piston	304	493293	Housing-Blower
29	499424	Rod-Connecting	305	691108	Screw (Blower Housing)
32	94699	Screw (Connecting Rod)	306	224324	Shield-Cylinder
33	262651	Valve-Exhaust	307	94515	Screw (Cylinder Shield)
34	262652	Valve-Intake	309	494233	Motor-Starter
35	262224	Spring-Valve	310	94051	Screw-Slotted Hex.
40	93312	Retainer-Valve	332	690662	Nut (Flywheel)
43	493737	Governor/Oil Slinger	333	802574	Armature-Magneto
45	262204	Tappet-Valve	334	94731	Screw (Magneto Armature)
46	498275	Gear-Cam	337	802592	Plug-Spark
48	498826	Short Block	356	398808	Wire-Stop
51	272199	★ Gasket-Intake	—	12J807-2960-B1	Replacement Engine
53	94525	Screw (Carburetor)			RPM Settings: Low Speed: 1900-2100 High Speed: 3000-3200
54	94526	Screw (Intake Manifold)			
55	497440	Housing-Rewind Starter			
56	498144	Pulley-Starter			
58	280399	Rope-Starter (Cut to Required Length)			
60	281434	Grip-Starter Rope			

NOTE: All component dimensions given in U.S. inches 1 inch = 25.4 mm

**BRIGGS & STRATTON
4-CYCLE ENGINE**

**MODEL NO. 12H807
TYPE NO. 2632-B1**

KEY PART NO.	NO.	DESCRIPTION	KEY PART NO.	NO.	DESCRIPTION
358	497316	Gasket Set	783	261606	Gear-Starter
363	19069	Flywheel-Puller	784	224262	Cover-Gear
373	92987	Nut (Rewind Starter Housing)	785	272201	Gasket-Cover
383	89838	Wrench-Spark Plug	789	493380	Harness-Wiring
404	67072	Washer (Governor Crank)	801	492335	Cap-Drive
423	93758	Screw (Interlock Switch)	802	492922	Cap-End
425	94872	Screw (Air Cleaner Cover)	803	492920	Housing-Starter
445	491588	Filter-A/C Cartridge	847	495263	Dipstick/Tube Assembly
455	225121	Cup-Flywheel	851	493880	Terminal-Cable
456	281503	Plate-Pawl Friction	869	213512	Seat-Valve (Intake)
459	281505	Pawl-Ratchet	870	213513	Seat-Valve (Exhaust)
474	492841	Alternator	871	262001	Bushing-Guide (Exhaust Valve)
510	494147	Drive-Starter		63709	Bushing-Guide (Intake Valve)
513	394815	Clutch-Drive	910	94510	Stud (Alternator)
523	495264	Dipstick	921	497233	Cover-Blower Housing
525	495265	Tube-Oil Fill	922	262640	Spring-Brake
529	281299	Grommet	923	493442	Brake
544	492921	Armature-Starter	935	398758	Switch-Interlock
548	492919	Washer Set (Starter)	937	281125	Spline-Starter
556	94512	Screw (Alternator)	957	397974	Cap-Fuel Tank
562	92613	Bolt (Governor Lever)	959	690877	Screw (Control bracket)
584	224328	Breather Passage Cover	966	496116	Base-A/C Primer
585	272238	★ Gasket-Breather Passage	967	493537	Filter-Pre Cleaner
592	231082	Nut (Governor Lever)	968	281340	Cover-Air Cleaner
597	94943	Screw (Pawl Friction Plate)	969	94696	Screw (Blower Housing Cover)
601	93053	Clamp-Fuel Line	971	94749	Screw (Support Bracket)
608	497680	Starter-Rewind	972	495224	Tank-Fuel
613	94231	Screw (Exhaust Muffler)	974	224815	Bracket-Support
615	94474	Retainer	975	493640	Bowl-Float
615A	93941	Retainer	976	496115	Primer-Carburetor
616	263175	Crank-Governor	977	498261	Gasket Set-Carburetor
617	270344	●◆ Seal-Intake Manifold	1019	494256	Label Kit
618	262749	Spring	1036	695111	Label Kit-Emission
621	396847	Switch-Stop	1058	273693	Owner's Manual
625	497465	Manifold-Intake	1059	398540	Screw/Washer Kit
634	280566	●◆ Seal-Throttle Shaft (Sold in Kit Only)	1087	280966	★ Seal-O-Ring
635	66538	Boot-Spark Plug	1095	498528	Gasket Set-Valve Overhaul
668	493823	★ Spacer (Includes 2)	1102	232153	Pilot-Guide
670	280512	Spacer-Fuel Tank	—	12J807-2960-B1	Replacement Engine
687	94515	Screw (Breather Passage Cover)			
689A	263073	Spring-Friction			RPM Settings: Low Speed: 1900-2100
741	262598	Gear-Timing			High Speed: 3000-3200
782	281127	Gear-Starter			

- ★ Included in Gasket Set, Ref Number 358.
- Included in Carburetor Kit, Ref Number 121.
- ◆ Included in Carburetor Gasket Set, Ref Number 977
- + Included in Valve Overhaul Kit, Ref Number 1095.

NOTE: All component dimensions given in U.S. inches 1 inch = 25.4 mm

Get it fixed, at your home or ours!

For repair of major brand appliances **In your own home...**
no matter who made it, no matter who sold it!

1-800-4-MY-HOMESM Anytime, day or night
(1-800-469-4663)

www.sears.com

To bring in products such as vacuums, lawn equipment and electronics
for repair, call for the location of your nearest **Sears Parts & Repair Center**

1-800-488-1222 Anytime, day or night

www.sears.com

For the replacement parts, accessories and owner's manuals
that you need to do-it-yourself, call **Sears PartsDirect**SM!

1-800-366-PART 6 a.m. - 11p.m. CST,
(1-800-366-7278) 7 days a week

www.sears.com/partsdirect

To purchase or inquire about a Sears Service Agreement :

1-800-827-6655

7 a.m. - 5 p.m. CST, Mon. - Sat.

Para pedir servicio de reparacin a domicilio,
y para ordenar piezas con entrega a domicilio:

1-888-SU-HOGARSM
(1-888-784-6427)

Au Canada pour service en franais:

1-877-LE-FOYERSM
(1-877-533-6937)

