

Owner's Manual

**CRAFTSMAN®**

**17.0 HP**

**ELECTRIC START**

**42" MOWER**

**AUTOMATIC**

**LAWN TRACTOR**

Model No.  
**917.270740**

**EZ<sup>3</sup>**

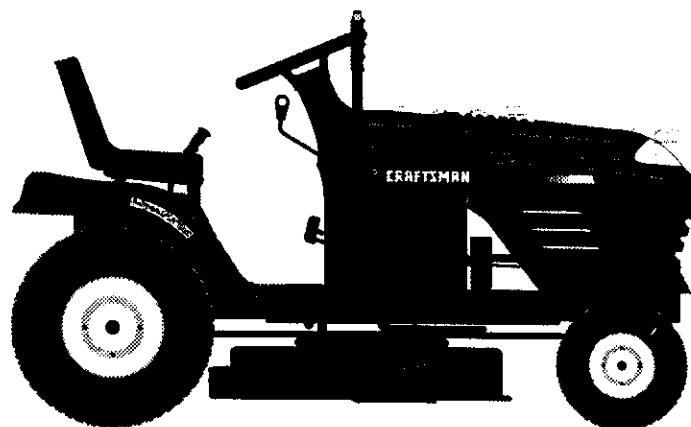

- Safety
- Assembly
- Operation
- Maintenance
- Repair Parts



This product has a low emission engine which operates differently from previously built engines. Before you start the engine, read and understand this Owner's Manual.

**CAUTION:**

Read and follow all Safety Rules and Instructions before operating this equipment.

For answers to your questions about this product, Call:

**1-800-659-5917**

Sears Craftsman Help Line  
5 am - 5 pm, Mon - Sat

Sears, Roebuck and Co., Hoffman Estates, IL 60179

Visit our Craftsman website: [www.sears.com/craftsman](http://www.sears.com/craftsman)

## TABLE OF CONTENTS

|                              |    |                               |            |
|------------------------------|----|-------------------------------|------------|
| Warranty .....               | 2  | Maintenance Schedule .....    | 17         |
| Safety Rules .....           | 2  | Service and Adjustments ..... | 21         |
| Product Specifications ..... | 5  | Storage .....                 | 28         |
| Assembly .....               | 7  | Troubleshooting .....         | 29         |
| Operation .....              | 10 | Repair Parts .....            | 34         |
| Maintenance .....            | 17 | Parts Ordering .....          | Back Cover |

## WARRANTY

### LIMITED TWO YEAR WARRANTY ON CRAFTSMAN RIDING EQUIPMENT

For two (2) years from the date of purchase, if this Craftsman Riding Equipment is maintained, lubricated and tuned up according to the instructions in the owner's manual, Sears will repair or replace, free of charge, any parts found to be defective in material or workmanship.

This Warranty does not cover:

- Expendable items which become worn during normal use, such as blades, spark plugs, air cleaners, belts, etc.
- Tire replacement or repair caused by punctures from outside objects, such as nails, thorns, stumps, or glass.
- Repairs necessary because of operator abuse, negligence, improper storage or accident or the failure to maintain the equipment according to the instructions contained in the owner's manual.
- Riding equipment used for commercial or rental purposes.

### LIMITED 90 DAY WARRANTY ON BATTERY

For ninety (90) days from date of purchase, if any battery included with this riding equipment proves defective in material or workmanship and our testing determines the battery will not hold a charge, Sears will replace the battery at no charge. In-home warranty service on your Craftsman riding equipment is available at no charge for 30 days from the date of purchase. Please contact your nearest service center. After 30 days from the date of purchase, warranty service is available by taking your Craftsman riding equipment to your nearest Sears Service Center. (In-home warranty service will still be available after 30 days from the date of purchase but a standard trip charge will apply). This warranty applies only while this product is in the United States. This Warranty gives you specific legal rights, and you may also have other rights which may vary from state to state.

Sears, Roebuck and Co., D/817 WA, Hoffman Estates, IL 60179

## SAFETY RULES

**IMPORTANT:** This cutting machine is capable of amputating hands and feet and throwing objects. Failure to observe the following safety instructions could result in serious injury or death.

### GENERAL OPERATION

- Read, understand, and follow all instructions in the manual and on the machine before starting.
- Only allow responsible adults, who are familiar with the instructions, to operate the machine.
- Clear the area of objects such as rocks, toys, wire, etc., which could be picked up and thrown by the blade.

- Be sure the area is clear of other people before mowing. Stop machine if anyone enters the area.
- Never carry passengers.
- Do not mow in reverse unless absolutely necessary. Always look down and behind before and while backing.
- Be aware of the mower discharge direction and do not point it at anyone. Do not operate the mower without either the entire grass catcher or the guard in place.
- Slow down before turning.
- Never leave a running machine unattended. Always turn off blades, set parking brake, stop engine, and remove keys before dismounting.

# SAFETY RULES

- Turn off blades when not mowing.
- Stop engine before removing grass catcher or unclogging chute.
- Mow only in daylight or good artificial light.
- Do not operate the machine while under the influence of alcohol or drugs.
- Watch for traffic when operating near or crossing roadways.
- Use extra care when loading or unloading the machine into a trailer or truck.
- Data indicates that operators, age 60 years and above, are involved in a large percentage of riding mower-related injuries. These operators should evaluate their ability to operate the riding mower safely enough to protect themselves and others from serious injury.

## SLOPE OPERATION

Slopes are a major factor related to loss-of-control and tipover accidents, which can result in severe injury or death. All slopes require extra caution. If you cannot back up the slope or if you feel uneasy on it, do not mow it.

### DO:

- Mow up and down slopes, not across.
- Remove obstacles such as rocks, tree limbs, etc.
- Watch for holes, ruts, or bumps. Uneven terrain could overturn the machine. Tall grass can hide obstacles.
- Use slow speed. Choose a low gear so that you will not have to stop or shift while on the slope.
- Follow the manufacturer's recommendations for wheel weights or counterweights to improve stability.
- Use extra care with grass catchers or other attachments. These can change the stability of the machine.
- Keep all movement on the slopes slow and gradual. Do not make sudden changes in speed or direction.
- Avoid starting or stopping on a slope. If tires lose traction, disengage the blades and proceed slowly straight down the slope.

### DO NOT:

- *Do not* turn on slopes unless necessary, and then, turn slowly and gradually downhill, if possible.
- *Do not* mow near drop-offs, ditches, or embankments. The mower could suddenly turn over if a wheel is over the edge of a cliff or ditch, or if an edge caves in.
- *Do not* mow on wet grass. Reduced traction could cause sliding.
- *Do not* try to stabilize the machine by putting your foot on the ground.
- *Do not* use grass catcher on steep slopes.

## CHILDREN

Tragic accidents can occur if the operator is not alert to the presence of children. Children are often attracted to the machine and the mowing activity. *Never* assume that children will remain where you last saw them.

- Keep children out of the mowing area and under the watchful care of another responsible adult.
- Be alert and turn machine off if children enter the area.
- Before and when backing, look behind and down for small children.
- Never carry children. They may fall off and be seriously injured or interfere with safe machine operation.
- Never allow children to operate the machine.
- Use extra care when approaching blind corners, shrubs, trees, or other objects that may obscure vision.

## SERVICE

- Use extra care in handling gasoline and other fuels. They are flammable and vapors are explosive.
  - Use only an approved container.
  - Never remove gas cap or add fuel with the engine running. Allow engine to cool before refueling. Do not smoke.
  - Never refuel the machine indoors.
  - Never store the machine or fuel container inside where there is an open flame, such as a water heater.
- Never run a machine inside a closed area.

## SAFETY RULES

- Keep nuts and bolts, especially blade attachment bolts, tight and keep equipment in good condition.
- Never tamper with safety devices. Check their proper operation regularly.
- Keep machine free of grass, leaves, or other debris build-up. Clean oil or fuel spillage. Allow machine to cool before storing.
- Stop and inspect the equipment if you strike an object. Repair, if necessary, before restarting.
- Never make adjustments or repairs with the engine running.
- Grass catcher components are subject to wear, damage, and deterioration, which could expose moving parts or allow objects to be thrown. Frequently check components and replace with manufacturer's recommended parts, when necessary.
- Mower blades are sharp and can cut. Wrap the blade(s) or wear gloves, and use extra caution when servicing them.

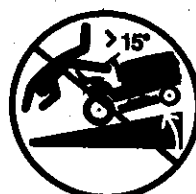

- Check brake operation frequently. Adjust and service as required.
- Be sure the area is clear of other people before mowing. Stop machine if anyone enters the area.
- Never carry passengers or children even with the blades off.
- Do not mow in reverse unless absolutely necessary. Always look down and behind before and while backing.
- Never carry children. They may fall off and be seriously injured or interfere with safe machine operation.
- Keep children out of the mowing area and under the watchful care of another responsible adult.
- Be alert and turn machine off if children enter the area.
- Before and when backing, look behind and *down* for small children.
- Mow up and down slopes (15° Max), not across.
- Remove obstacles such as rocks, tree limbs, etc.
- Watch for holes, ruts, or bumps. Uneven terrain could overturn the machine. *Tall grass can hide obstacles.*
- Use slow speed. Choose a low gear so that you will not have to stop or shift while on the slope.
- Avoid starting or stopping on a slope. If tires lose traction, disengage the blades and proceed slowly *straight* down the slope.
- If machine stops while going uphill, disengage blades, shift into reverse and back down slowly.
- *Do not* turn on slopes unless necessary, and then, turn slowly and gradually downhill, if possible.

**⚠** Look for this symbol to point out important safety precautions. It means **CAUTION!!! BECOME AWARE!!! YOUR SAFETY IS INVOLVED.**

**⚠ CAUTION:** In order to prevent accidental starting when setting up, transporting, adjusting or making repairs always disconnect spark plug wire and place wire where it cannot contact spark plug.

**⚠ CAUTION:** Do not coast down a hill in neutral, you may lose control of the tractor.

**⚠ CAUTION:** Tow only the attachments that are recommended by and comply with specifications of the manufacturer of your tractor. Use common sense when towing. Operate only at the lowest possible speed when on a slope. Too heavy of a load, while on a slope, is dangerous. Tires can lose traction with the ground and cause you to lose control of your tractor.

**⚠ WARNING:** The engine exhaust from this product contains chemicals known to the State of California to cause cancer, birth defects, or other reproductive harm.

## PRODUCT SPECIFICATIONS

|                             |                                               |
|-----------------------------|-----------------------------------------------|
| GASOLINE CAPACITY AND TYPE: | 1.25 GALLONS UNLEADED REGULAR                 |
| OIL TYPE (API-SF/SG/SH):    | SAE 30 (ABOVE 32°F)<br>SAE 5W-30 (BELOW 32°F) |
| OIL CAPACITY:               | 3.0 PINTS                                     |
| SPARK PLUG (GAP: .030")     | CHAMPION RJ19LM OR J19LM                      |
| VALVE CLEARANCE:            | INTAKE: .005-.007<br>EXHAUST: .009-.011       |
| GROUND SPEED FORWARD (MPH): | 5.5<br>REVERSE: 2.4                           |
| TIRE PRESSURE:              | FRONT: 14 PSI<br>REAR: 10 PSI                 |
| CHARGING SYSTEM:            | 3 AMPS BATTERY<br>5 AMPS HEADLIGHTS           |
| BATTERY:                    | AMP/HR: 25<br>MIN. CCA: 190<br>CASE SIZE: U1R |
| BLADE BOLT TORQUE:          | 27-35 FT. LBS.                                |

**CONGRATULATIONS** on your purchase of a Craftsman Tractor. It has been designed, engineered and manufactured to give you the best possible dependability and performance.

Should you experience any problem you cannot easily remedy, please contact your nearest Sears Authorized Service Center. We have competent, well-trained technicians and the proper tools to service or repair this tractor.

Please read and retain this manual. The instructions will enable you to assemble and maintain your tractor properly. Always observe the "SAFETY RULES".

## MAINTENANCE AGREEMENT

A Sears Maintenance Agreement is available on this product. Contact your nearest Sears store for details.

## CUSTOMER RESPONSIBILITIES

- Read and observe the safety rules.
- Follow a regular schedule in maintaining, caring for and using your tractor.
- Follow the instructions under "Maintenance" and "Storage" sections of this owner's manual.

**▲ WARNING:** This tractor is equipped with an internal combustion engine and should not be used on or near any unimproved forest-covered, brush-covered or grass-covered land unless the engine's exhaust system is equipped with a spark arrester meeting applicable local or state laws (if any). If a spark arrester is used, it should be maintained in effective working order by the operator.

In the state of California the above is required by law (Section 4442 of the California Public Resources Code). Other states may have similar laws. Federal laws apply on federal lands. A spark arrester for the muffler is available through your nearest authorized service center/department (See REPAIR PARTS section of this manual).

# UNASSEMBLED PARTS

## Steering Wheel

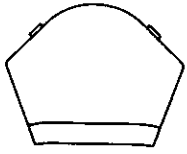

Steering Wheel Insert

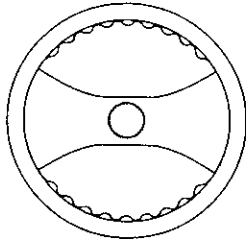

(1) Hex Bolt 3/8-16 x 1

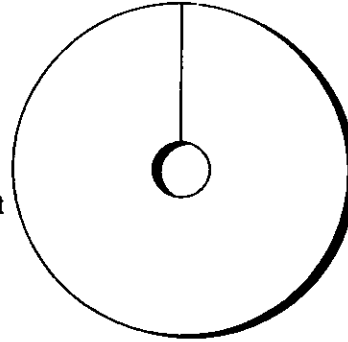

(1) Large Flat Washer



(1) Hex Bolt 5/16-18 x 1-1/4



(1) Locknut 5/16-18

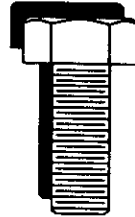

(1) Lockwasher 3/8



Steering Wheel Adapter

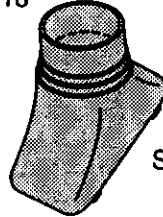

Steering Boot



Steering Extension Shaft

## Seat

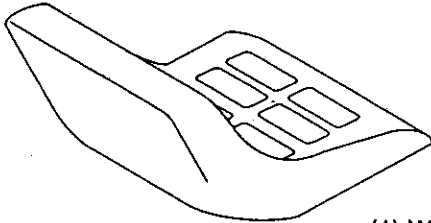

(1) Washer 17/32 x 1-3/16 x 12 Gauge  
(1) Knob

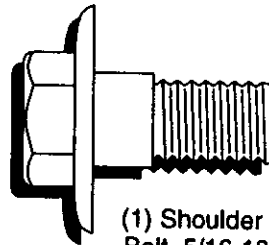

(1) Shoulder Bolt 5/16-18

## Keys

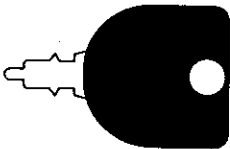

(2) Keys

## Video Cassette

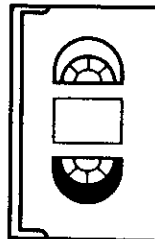

## Slope Sheet

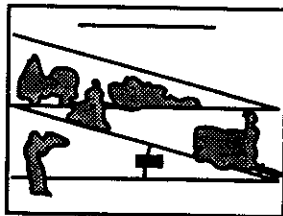

# ASSEMBLY

Your new tractor has been assembled at the factory with exception of those parts left unassembled for shipping purposes. To ensure safe and proper operation of your tractor all parts and hardware you assemble must be tightened securely. Use the correct tools as necessary to insure proper tightness. Review the video cassette before you begin.

## TOOLS REQUIRED FOR ASSEMBLY

A socket wrench set will make assembly easier. Standard wrench sizes you need are listed below.

- (1) 9/16" wrench
- (1) Pliers
- (2) 1/2" wrench
- (1) Utility knife
- (1) Tire pressure gauge

When right or left hand is mentioned in this manual, it means, from your point of view, when you are in the operating position (seated behind the steering wheel).

## TO REMOVE TRACTOR FROM CARTON

### UNPACK CARTON

- Remove all accessible loose parts and parts boxes from shipping carton.
- Cut, from top to bottom, along lines on all four corners of shipping carton, and lay panels flat.
- Check for any additional loose parts or boxes and remove.

## BEFORE ROLLING TRACTOR OFF SKID

### ATTACH STEERING WHEEL

### ASSEMBLE EXTENSION SHAFT AND BOOT

- Slide extension shaft onto lower steering shaft. Align mounting holes in extension and lower shafts and install 5/16 hex bolt and locknut. Tighten securely.
- Place tabs of steering boot over tab slots in dash and push down to secure.

### INSTALL STEERING WHEEL

- Position front wheels of the tractor so they are pointing straight forward.
- Remove steering wheel adapter from steering wheel and slide adapter onto steering shaft extension.
- Position steering wheel so cross bars are horizontal (left to right) and slide inside boot and onto adapter.

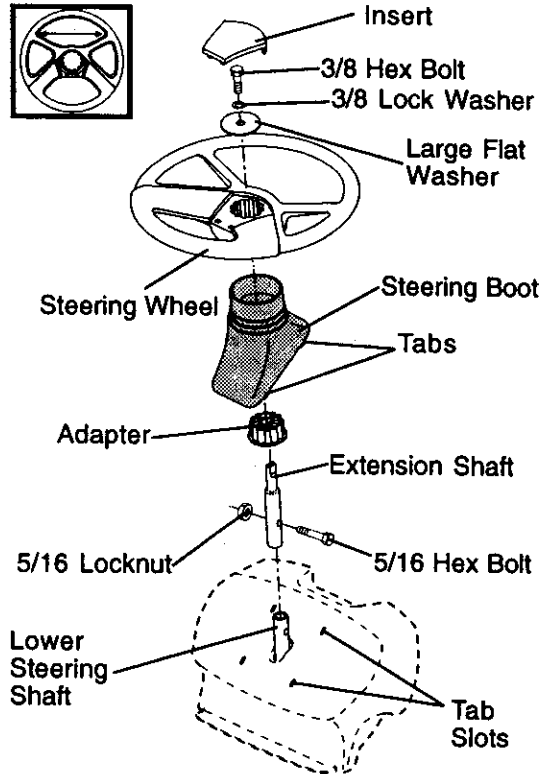

- Assemble large flat washer, 3/8 lock washer, 3/8 hex bolt and tighten securely.
- Snap steering wheel insert into center of steering wheel.
- Remove protective materials from tractor hood and grill.

**IMPORTANT:** Check for and remove any staples in skid that may puncture tires where tractor is to roll off skid.

## HOW TO SET UP YOUR TRACTOR

### CHECK BATTERY

- Lift seat pan to raised position and open battery box door.
- If this battery is put into service after month and year indicated on label (label located between terminals) charge battery for minimum of one hour at 6-10 amps. (See "BATTERY" in MAINTENANCE section of this manual for charging instructions.)

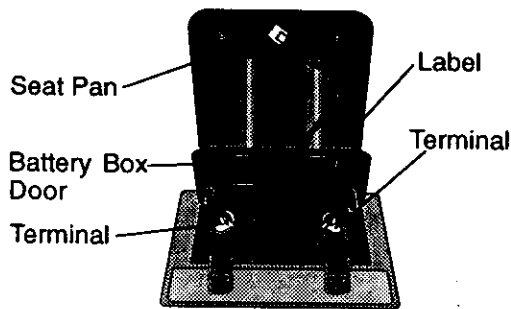

### INSTALL SEAT

Adjust seat before tightening adjustment knob.

- Remove adjustment knob and flat washer securing seat to cardboard packing and set aside for assembly of seat to tractor.
- Pivot seat upward and remove from the cardboard packing. Remove the cardboard packing and discard.
- Place seat on seat pan and assemble shoulder bolt. Tighten shoulder bolt securely.
- Assemble adjustment knob and flat washer loosely. Do not tighten.
- Lower seat into operating position and sit on seat.
- Slide seat until a comfortable position is reached which allows you to press clutch/brake pedal all the way down.
- Get off seat without moving its adjusted position.
- Raise seat and tighten adjustment knob securely.

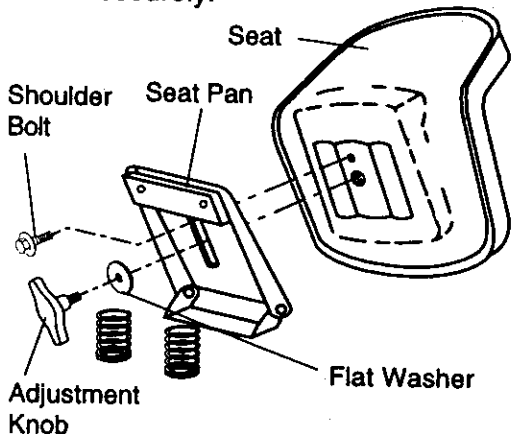

**NOTE:** You may now roll or drive your tractor off the skid. Follow the appropriate instruction below to remove the tractor from the skid.

### TO ROLL TRACTOR OFF SKID (See Operation section for location and function of controls)

- Press lift lever plunger and raise attachment lift lever to its highest position.
- Release parking brake by depressing clutch/brake pedal.
- Place freewheel control in freewheeling position to disengage transmission (See "TO TRANSPORT" in the Operation section of this manual).
- Roll tractor forward off skid.
- Remove banding holding discharge guard up against tractor.

### TO DRIVE TRACTOR OFF SKID (See Operation section for location and function of controls)

**WARNING:** Before starting, read, understand and follow all instructions in the Operation section of this manual. Be sure tractor is in a well-ventilated area. Be sure the area in front of tractor is clear of other people and objects.

- Be sure all the above assembly steps have been completed.
  - Check engine oil level and fill fuel tank with gasoline.
  - Place freewheel control in "transmission engaged" position.
  - Sit on seat in operating position, depress clutch/brake pedal and set the parking brake.
  - Place motion control lever in neutral (N) position.
  - Press lift lever plunger and raise attachment lift lever to its highest position.
  - Start the engine. After engine has started, move throttle control to idle position.
  - Release parking brake.
  - Slowly move the motion control lever forward and slowly drive tractor off skid.
  - Apply brake to stop tractor, set parking brake and place motion control lever in neutral position.
  - Turn ignition key to "OFF" position.
- Continue with the instructions that follow.



## INSTALL MULCHER PLATE

(If previously removed)

- Raise and hold deflector shield in upright position.
- Place front of mulcher plate over front of mower deck opening and slide into place, as shown.
- Hook front latch into hole on front of mower deck.
- Hook rear latch into hole on back of mower deck.

**CAUTION:** Do not remove deflector shield from mower. Raise and hold shield when attaching mulcher plate and allow it to rest on plate while in operation.

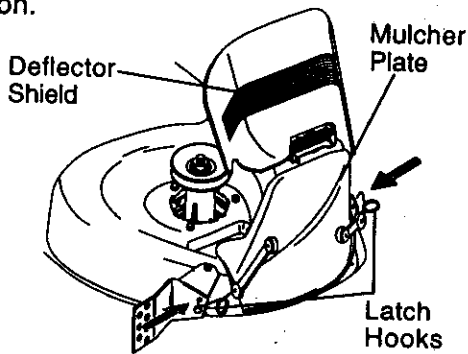

## TO CONVERT TO BAGGING OR DISCHARGING

Simply remove mulcher plate and store in a safe place. Your mower is now ready for discharging or installation of optional grass catcher accessory.

**NOTE:** It is not necessary to change blades. The mulcher blades are designed for discharging and bagging also.

## CHECK TIRE PRESSURE

The tires on your tractor were overinflated at the factory for shipping purposes. Correct tire pressure is important for best cutting performance.

- Reduce tire pressure to PSI shown in "PRODUCT SPECIFICATIONS" section of this manual.

## CHECK DECK LEVELNESS

For best cutting results, mower housing should be properly leveled. See "TO LEVEL MOWER HOUSING" in the Service and Adjustments section of this manual.

## CHECK FOR PROPER POSITION OF ALL BELTS

See the figures that are shown for replacing motion and mower blade drive

belts in the Service and Adjustments section of this manual. Verify that the belts are routed correctly.

## CHECK BRAKE SYSTEM

After you learn how to operate your tractor, check to see that the brake is properly adjusted. See "TO ADJUST BRAKE" in the Service and Adjustments section of this manual.

### ✓CHECKLIST

Before you operate and enjoy your new tractor, we wish to assure that you receive the best performance and satisfaction from this quality product.

Please review the following checklist:

- ✓ All assembly instructions have been completed.
  - ✓ No remaining loose parts in carton.
  - ✓ Battery is properly prepared and charged. (Minimum 1 hour at 6 amps).
  - ✓ Seat is adjusted comfortably and tightened securely.
  - ✓ All tires are properly inflated. (For shipping purposes, the tires were overinflated at the factory).
  - ✓ Be sure mower deck is properly leveled side-to-side/front-to-rear for best cutting results. (Tires must be properly inflated for leveling).
  - ✓ Check mower and drive belts. Be sure they are routed properly around pulleys and inside all belt keepers.
  - ✓ Check wiring. See that all connections are still secure and wires are properly clamped.
  - ✓ Before driving tractor, be sure free-wheel control is in drive position.
- While learning how to use your tractor, pay extra attention to the following important items:
- ✓ Engine oil is at proper level.
  - ✓ Fuel tank is filled with fresh, clean, regular unleaded gasoline.
  - ✓ Become familiar with all controls - their location and function. Operate them before you start the engine.
  - ✓ Be sure brake system is in safe operating condition.
  - ✓ It is important to purge the transmission before operating your tractor for the first time. Follow proper starting and transmission purging instructions (See "TO START ENGINE" and "PURGE TRANSMISSION" in the Operation section of this manual).

# OPERATION

These symbols may appear on your tractor or in literature supplied with the product. Learn and understand their meaning.



BATTERY



CAUTION OR WARNING



REVERSE



FORWARD



FAST



SLOW



ENGINE ON



ENGINE OFF



OIL PRESSURE



LIGHTS ON



OVER TEMP LIGHT

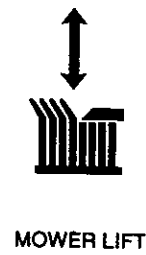

MOWER LIFT



FUEL



CHOKE



MOWER HEIGHT



PARKING BRAKE LOCKED



UNLOCKED



ATTACHMENT CLUTCH ENGAGED



REVERSE



NEUTRAL



HIGH



LOW



PARKING BRAKE



IGNITION



ATTACHMENT CLUTCH DISENGAGED



KEEP AREA CLEAR



SLOPE HAZARDS

(SEE SAFETY RULES SECTION)

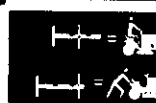
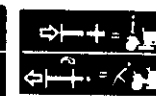
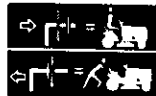

FREE WHEEL  
(Automatic Models only)



DANGER, KEEP HANDS AND FEET AWAY

## KNOW YOUR TRACTOR

### READ THIS OWNER'S MANUAL AND SAFETY RULES BEFORE OPERATING YOUR TRACTOR

Compare the illustrations with your tractor to familiarize yourself with the locations of various controls and adjustments. Save this manual for future reference.

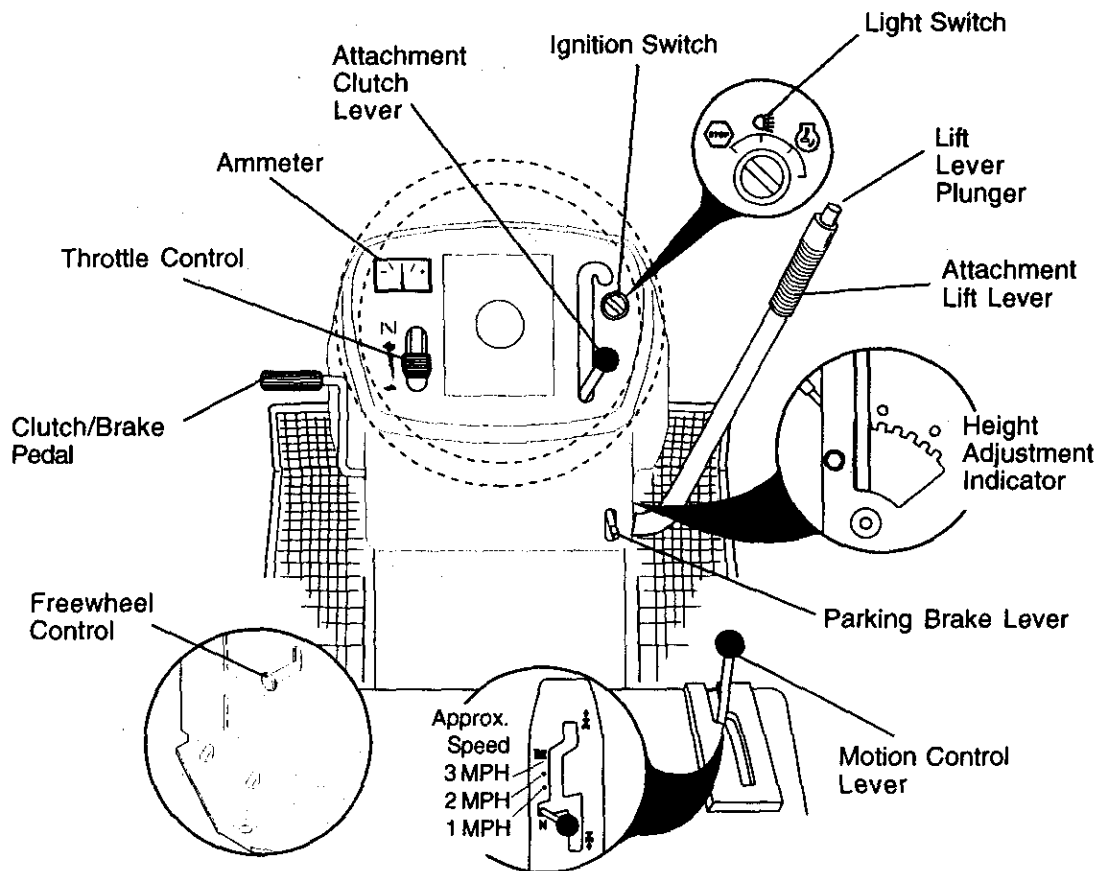

---

Our tractors conform to the safety standards of the American National Standards Institute.

---

**AMMETER** - Indicates charging (+) or discharging (-) of battery.

**ATTACHMENT CLUTCH LEVER** - Used to engage the mower blades, or other attachments mounted to your tractor.

**ATTACHMENT LIFT LEVER** - Used to raise, lower, and adjust the mower deck or other attachments mounted to your tractor.

**CLUTCH/BRAKE PEDAL** - Used for declutching and braking the tractor and starting the engine.

**MOTION CONTROL LEVER** - Selects the speed and direction of tractor.

**IGNITION SWITCH** - Used for starting and stopping the engine.

**LIFT LEVER PLUNGER** - Used to release attachment lift lever when changing its position.

**LIGHT SWITCH** - Turns the headlights on and off.

**PARKING BRAKE LEVER** - Locks clutch/brake pedal into the brake position.

**THROTTLE/CHOKE CONTROL** - Used for starting and controlling engine speed.

**FREEWHEEL CONTROL** - Disengages transmission for pushing or slowly towing the tractor with the engine off.



The operation of any tractor can result in foreign objects thrown into the eyes, which can result in severe eye damage. Always wear safety glasses or eye shields while operating your tractor or performing any adjustments or repairs. We recommend a wide vision safety mask over spectacles or standard safety glasses.

## HOW TO USE YOUR TRACTOR TO SET PARKING BRAKE

Your tractor is equipped with an operator presence sensing switch. When engine is running, any attempt by the operator to leave the seat without first setting the parking brake will shut off the engine.

- Depress clutch/brake pedal into full "BRAKE" position and hold.
- Place parking brake lever in "ENGAGED" position and release pressure from clutch/brake pedal. Pedal should remain in "BRAKE" position. Make sure parking brake will hold tractor secure.

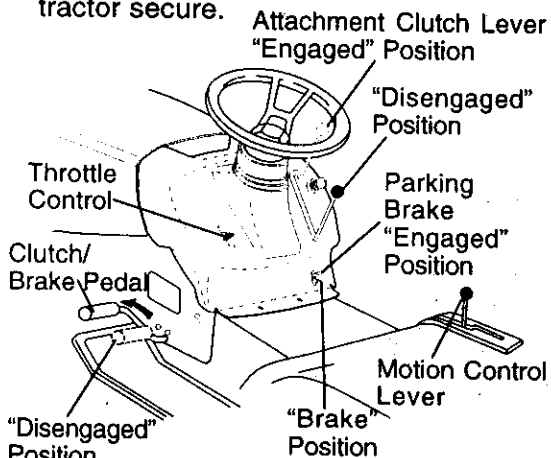

## STOPPING

### MOWER BLADES -

- To stop mower blades, move attachment clutch lever to "DISENGAGED" position.

### GROUND DRIVE -

- To stop ground drive, depress clutch/brake pedal into full "BRAKE" position.
- Move motion control lever to neutral (N) position.

**IMPORTANT:** The motion control lever does not return to neutral (N) position when the clutch/brake pedal is depressed.

### ENGINE -

- Move throttle control to slow position.
- NOTE:** Failure to move throttle control to slow position and allowing engine to idle before stopping may cause engine to "backfire".

- Turn ignition key to "OFF" position and remove key. Always remove key when leaving tractor to prevent unauthorized use.

- Never use choke to stop engine.

**IMPORTANT:** Leaving the ignition switch in any position other than "OFF" will cause the battery to be discharged, (dead).

**NOTE:** Under certain conditions when tractor is standing idle with the engine running, hot engine exhaust gases may cause "browning" of grass. To eliminate this possibility, always stop engine when stopping tractor on grass areas.

**CAUTION:** Always stop tractor completely, as described above, before leaving the operator's position; to empty grass catcher, etc.

## TO USE THROTTLE CONTROL

Always operate engine at full throttle.

- Operating engine at less than full throttle reduces the battery charging rate.
- Full throttle offers the best bagging and mower performance.

## TO MOVE FORWARD AND BACKWARD

The direction and speed of movement is controlled by the motion control lever.

- Start tractor with motion control lever in neutral (N) position.
- Release parking brake and clutch/brake pedal.
- Slowly move motion control lever to desired position.

## TO ADJUST MOWER CUTTING HEIGHT

The position of the attachment lift lever determines the cutting height.

- Grasp lift lever.
- Press plunger with thumb and move lever to desired position.

The cutting height range is approximately 1-1/2 to 4". The heights are measured from the ground to the blade tip with the engine not running. These heights are approximate and may vary depending upon soil conditions, height

of grass and types of grass being mowed.

- The average lawn should be cut to approximately 2-1/2 inches during the cool season and to over 3 inches during hot months. For healthier and better looking lawns, mow often and after moderate growth.
- For best cutting performance, grass over 6 inches in height should be mowed twice. Make the first cut relatively high; the second to desired height.

### TO ADJUST GAUGE WHEELS

Gauge wheels are properly adjusted when they are slightly off the ground when mower is at the desired cutting height in operating position. Gauge wheels then keep the deck in proper position to help prevent scalping in most terrain conditions.

- Adjust gauge wheels with tractor on a flat level surface.
- Adjust mower to desired cutting height (See "TO ADJUST MOWER CUTTING HEIGHT" in the Operation section of this manual).
- With mower in desired height of cut position, gauge wheels should be assembled so they are slightly off the ground. Install gauge wheel in appropriate hole with shoulder bolt, 3/8 washer, and 3/8-16 locknut and tighten securely.
- Repeat for opposite side installing gauge wheel in same adjustment hole.

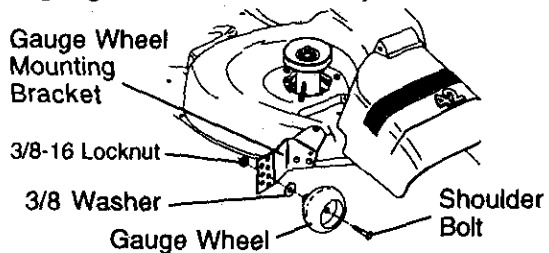

### TO OPERATE MOWER

Your tractor is equipped with an operator presence sensing switch. Any attempt by the operator to leave the seat with the engine running and the attachment clutch engaged will shut off the engine.

- Select desired height of cut.
- Start mower blades by engaging attachment clutch control.
- TO STOP MOWER BLADES - disengage attachment clutch control.

**CAUTION:** Do not operate the mower without either the entire grass catcher, on mowers so equipped, or the deflector shield in place.

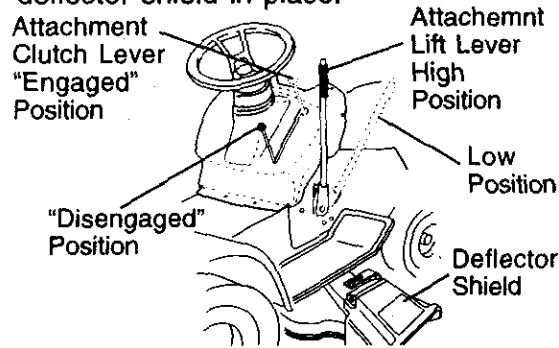

### TO OPERATE ON HILLS

**CAUTION:** Do not drive up or down hills with slopes greater than 15° and do not drive across any slope.

- Choose the slowest speed before starting up or down hills.
- Avoid stopping or changing speed on hills.
- If slowing is necessary, move throttle control lever to slower position.
- If stopping is absolutely necessary, push clutch/brake pedal quickly to brake position and engage parking brake.
- Move motion control lever to neutral (N) position.

**IMPORTANT:** The motion control lever does not return to neutral (N) position when the clutch/brake pedal is depressed.

- To restart movement, slowly release parking brake and clutch/brake pedal.
- Slowly move motion control lever to slowest setting.
- Make all turns slowly.

### TO TRANSPORT

When pushing or towing your tractor, be sure to disengage transmission by placing freewheel control in freewheeling position. Free wheel control is located at the rear drawbar of tractor.

- Raise attachment lift to highest position with attachment lift control.
- Pull freewheel control out and down into the slot and release so it is held in the disengaged position.
- Do not push or tow tractor at more than two (2) MPH.
- To reengage transmission, reverse above procedure.

**NOTE:** To protect hood from damage when transporting your tractor on a truck or a trailer, be sure hood is closed and secured to tractor. Use an appropriate means of tying hood to tractor (rope, cord, etc.).

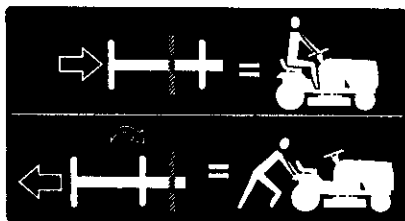

## TOWING CARTS AND OTHER ATTACHMENTS

Tow only the attachments that are recommended by and comply with specifications of the manufacturer of your tractor. Use common sense when towing. Too heavy of a load, while on a slope, is dangerous. Tires can lose traction with the ground and cause you to lose control of your tractor.

## BEFORE STARTING THE ENGINE CHECK ENGINE OIL LEVEL

- The engine in your tractor has been shipped, from the factory, already filled with summer weight oil.
- Check engine oil with tractor on level ground.
- Remove oil fill cap/dipstick and wipe clean, reinsert the dipstick and screw cap tight, wait for a few seconds, remove and read oil level. If necessary, add oil until "FULL" mark on dipstick is reached. Do not overfill.
- For cold weather operation you should change oil for easier starting (See "OIL VISCOSITY CHART" in the Maintenance section of this manual).
- To change engine oil, see the Maintenance section in this manual.

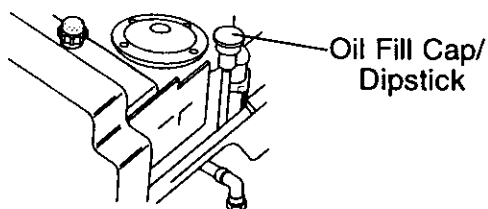

## ADD GASOLINE

- Fill fuel tank. Use fresh, clean, regular unleaded gasoline with a minimum of 87 octane. (Use of leaded gasoline will increase carbon and lead oxide deposits and reduce valve life).

Do not mix oil with gasoline. Purchase fuel in quantities that can be used within 30 days to assure fuel freshness.

**IMPORTANT:** When operating in temperatures below 32°F(0°C), use fresh, clean winter grade gasoline to help insure good cold weather starting.

**⚠ WARNING:** Experience indicates that alcohol blended fuels (called gasohol or using ethanol or methanol) can attract moisture which leads to separation and formation of acids during storage. Acidic gas can damage the fuel system of an engine while in storage. To avoid engine problems, the fuel system should be emptied before storage of 30 days or longer. Drain the gas tank, start the engine and let it run until the fuel lines and carburetor are empty. Use fresh fuel next season. See Storage Instructions for additional information. Never use engine or carburetor cleaner products in the fuel tank or permanent damage may occur.

**⚠ CAUTION:** Fill to bottom of gas tank filler neck. Do not overfill. Wipe off any spilled oil or fuel. Do not store, spill or use gasoline near an open flame.

## TO START ENGINE

When starting the engine for the first time or if the engine has run out of fuel, it will take extra cranking time to move fuel from the tank to the engine.

- Be sure freewheel control is in the transmission engaged position.
- Sit on seat in operating position, depress clutch/brake pedal and set parking brake.
- Place motion control lever in neutral (N) position.
- Move attachment clutch to "DISENGAGED" position.
- Move throttle control to choke position.

**NOTE:** Before starting, read the warm and cold starting procedures below.

- Insert key into ignition and turn key clockwise to "START" position and release key as soon as engine starts. Do not run starter continuously for more than fifteen seconds per minute. If the engine does not start after several attempts, move throttle control to fast position, wait a few minutes and try again. If engine still does not start, move the throttle control back to the choke position and retry.

### WARM WEATHER STARTING (50° F and above)

- When engine starts, move the throttle control to the fast position.
- The attachments and ground drive can now be used. If the engine does not accept the load, restart the engine and allow it to warm up for one minute using the choke as described above.

### COLD WEATHER STARTING ( 50° F and below)

- When engine starts, allow engine to run with the throttle control in the choke position until the engine runs roughly, then move throttle control to fast position. This may require an engine warm-up period from several seconds to several minutes, depending on the temperature.

### AUTOMATIC TRANSMISSION WARM UP

- Before driving the unit in cold weather, the transmission should be warmed up as follows:
- Be sure the tractor is on level ground.
- Place the motion control lever in neutral. Release the parking brake and let the clutch/brake slowly return to operating position.
- Allow one minute for transmission to warm up. This can be done during the engine warm up period.
- The attachments can also be used during the engine warm-up period after the transmission has been warmed up.

**NOTE:** If at a high altitude (above 3000 feet) or in cold temperatures (below 32 F) the carburetor fuel mixture may need to be adjusted for best engine performance. See "TO ADJUST CARBURETOR" in the Service and Adjustments section of this manual.

### PURGE TRANSMISSION

**CAUTION:** Never engage or disengage freewheel lever while the engine is running.

To ensure proper operation and performance, it is recommended that the transmission be purged before operating tractor for the first time. This procedure will remove any trapped air inside the transmission which may have developed during shipping of your tractor.

**IMPORTANT:** Should your transmission require removal for service or replacement, it should be purged after reinstallation before operating the tractor.

- Place tractor safely on level surface with engine off and parking brake set.
- Disengage transmission by placing freewheel control in freewheeling position (See "TO TRANSPORT" in this section of manual).
- Sitting in the tractor seat, start engine. After the engine is running, move throttle control to slow position. With motion control lever in neutral (N) position, slowly disengage clutch/brake pedal.
- Move motion control lever to full forward position and hold for five (5) seconds. Move lever to full reverse position and hold for five (5) seconds. Repeat this procedure three (3) times.

**NOTE:** During this procedure there will be no movement of drive wheels. The air is being removed from hydraulic drive system.

- Move motion control lever to neutral (N) position. Shut-off engine and set parking brake.
- Engage transmission by placing freewheel control in driving position (See "TO TRANSPORT" in this section of manual).
- Sitting in the tractor seat, start engine. After the engine is running, move throttle control to half (1/2) speed. With motion control lever in neutral (N) position, slowly disengage clutch/brake pedal.
- Slowly move motion control lever forward, after the tractor moves approximately five (5) feet, slowly move motion control lever to reverse position. After the tractor moves approximately five (5) feet return the motion control lever to the neutral (N) position. Repeat this procedure with the motion control lever three (3) times.
- Your tractor is now purged and now ready for normal operation.

## MOWING TIPS

- Mower should be properly leveled for best mowing performance. See "TO LEVEL MOWER HOUSING" in the Service and Adjustments section of this manual.
- The left hand side of mower should be used for trimming.
- Drive so that clippings are discharged onto the area that has been cut. Have the cut area to the right of the tractor. This will result in a more even distribution of clippings and more uniform cutting.
- When mowing large areas, start by turning to the right so that clippings will discharge away from shrubs, fences, driveways, etc. After one or two rounds, mow in the opposite direction making left hand turns until finished.
- If grass is extremely tall, it should be mowed twice to reduce load and possible fire hazard from dried clippings. Make first cut relatively high; the second to the desired height.
- Do not mow grass when it is wet. Wet grass will plug mower and leave undesirable clumps. Allow grass to dry before mowing.
- **Always operate engine at full throttle when mowing** to assure better mowing performance and proper discharge of material. Regulate ground speed by selecting a low enough gear to give the mower cutting performance as well as the quality of cut desired.
- When operating attachments, select a ground speed that will suit the terrain and give best performance of the attachment being used.

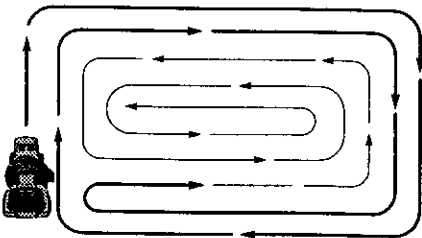

## MULCHING MOWING TIPS

**IMPORTANT:** For best performance, keep mower housing free of built-up grass and trash. Clean after each use.

- The special mulching blade will recut the grass clippings many times and reduce them in size so that as they fall onto the lawn they will disperse into the grass and not be noticed. Also, the mulched grass will biodegrade quickly to provide nutrients for the lawn. Always mulch with your highest engine (blade) speed as this will provide the best recutting action of the blades.
- Avoid cutting your lawn when it is wet. Wet grass tends to form clumps and interferes with the mulching action. The best time to mow your lawn is the early afternoon. At this time the grass has dried and the newly cut area will not be exposed to the direct sun.
- For best results, adjust the mower cutting height so that the mower cuts off only the top one-third of the grass blades. For extremely heavy mulching, reduce your width of cut on each pass and mow slowly.
- Certain types of grass and grass conditions may require that an area be mulched a second time to completely hide the clippings. When doing a second cut, mow across or perpendicular to the first cut path.
- Change your cutting pattern from week to week. Mow north to south one week then change to east to west the next week. This will help prevent matting and graining of the lawn.

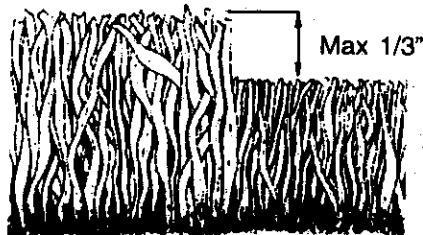



# MAINTENANCE

| MAINTENANCE SCHEDULE                                |                                               | SERVICE DATES   |               |                   |                  |                 |              |                |
|-----------------------------------------------------|-----------------------------------------------|-----------------|---------------|-------------------|------------------|-----------------|--------------|----------------|
| FILL IN DATES<br>AS YOU COMPLETE<br>REGULAR SERVICE |                                               | BEFORE EACH USE | EVERY 8 HOURS | EVERY 25 HOURS    | EVERY 50 HOURS   | EVERY 100 HOURS | EVERY SEASON | BEFORE STORAGE |
| <b>T<br/>R<br/>A<br/>C<br/>T<br/>O<br/>R</b>        | Check Brake Operation                         | ✓               | ✓             |                   |                  |                 |              |                |
|                                                     | Check Tire Pressure                           | ✓               | ✓             |                   |                  |                 |              |                |
|                                                     | Check Operator Presence and Interlock Systems | ✓               |               |                   |                  |                 |              |                |
|                                                     | Check for Loose Fasteners                     | ✓               |               |                   | ✓ <sub>7</sub>   |                 | ✓            |                |
|                                                     | Sharpen/Replace Mower Blades                  |                 |               | ✓ <sub>4</sub>    |                  |                 |              |                |
|                                                     | Lubrication Chart                             |                 |               | ✓                 |                  |                 | ✓            |                |
|                                                     | Check Battery Level                           |                 |               | ✓ <sub>5</sub>    |                  |                 |              |                |
|                                                     | Clean Battery and Terminals                   |                 |               | ✓                 |                  |                 | ✓            |                |
|                                                     | Check Transaxle Cooling                       |                 |               | ✓                 |                  |                 |              |                |
|                                                     | Adjust Blade Belt(s) Tension                  |                 |               |                   | ✓ <sub>5</sub>   |                 |              |                |
|                                                     | Adjust Motion Drive Belt(s) Tension           |                 |               |                   | ✓ <sub>5</sub>   |                 |              |                |
| <b>E<br/>N<br/>G<br/>I<br/>N<br/>E</b>              | Check Engine Oil Level                        | ✓               | ✓             |                   |                  |                 |              |                |
|                                                     | Change Engine Oil                             |                 |               | ✓ <sub>12,3</sub> |                  |                 | ✓            |                |
|                                                     | Clean Air Filter                              |                 |               | ✓ <sub>2</sub>    |                  |                 |              |                |
|                                                     | Clean Air Screen                              |                 |               | ✓ <sub>2</sub>    |                  |                 |              |                |
|                                                     | Inspect Muffler/Spark Arrester                |                 |               |                   | ✓                |                 |              |                |
|                                                     | Replace Oil Filter (If equipped)              |                 |               |                   | ✓ <sub>1,2</sub> |                 |              |                |
|                                                     | Clean Engine Cooling Fins                     |                 |               |                   | ✓ <sub>2</sub>   |                 |              |                |
|                                                     | Replace Spark Plug                            |                 |               |                   | ✓                | ✓               |              |                |
|                                                     | Replace Air Filter Paper Cartridge            |                 |               |                   | ✓ <sub>2</sub>   |                 |              |                |
|                                                     | Replace Fuel Filter                           |                 |               |                   |                  |                 | ✓            |                |

- 1 - Change more often when operating under a heavy load or in high ambient temperatures.    5 - If equipped with adjustable system.  
 2 - Service more often when operating in dirty or dusty conditions.    6 - Not required if equipped with maintenance-free battery.  
 3 - If equipped with oil filter, change oil every 50 hours.    7 - Tighten front axle pivot bolt to 35 ft.-lbs. maximum.  
 4 - Replace blades more often when mowing in sandy soil.    Do not overtighten.

## GENERAL RECOMMENDATIONS

The warranty on this tractor does not cover items that have been subjected to operator abuse or negligence. To receive full value from the warranty, operator must maintain tractor as instructed in this manual.

Some adjustments will need to be made periodically to properly maintain your tractor.

All adjustments in the Service and Adjustments section of this manual should be checked at least once each season.

- Once a year you should replace the spark plug, clean or replace air filter, and check blades and belts for wear. A new spark plug and clean air filter assure proper air-fuel mixture and help your engine run better and last longer.

### BEFORE EACH USE

- Check engine oil level.
- Check brake operation.
- Check tire pressure.
- Check operator presence and interlock systems for proper operation.
- Check for loose fasteners.

## LUBRICATION CHART

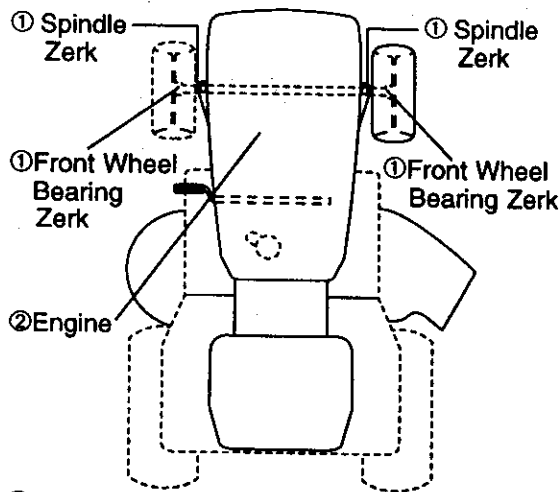

- ① SAE 30 or 10w30 MOTOR OIL  
 ② REFER TO Maintenance "ENGINE" SECTION
- IMPORTANT:** Do not oil or grease the pivot points which have special nylon bearings. Viscous lubricants will attract dust and dirt that will shorten the life of the self-lubricating bearings. If you feel they must be lubricated, use only a dry, powdered graphite type lubricant sparingly.

## TRACTOR

Always observe safety rules when performing any maintenance.

### BRAKE OPERATION

If tractor requires more than six (6) feet stopping distance at high speed in highest gear, then brake must be adjusted. (See "TO ADJUST BRAKE" in the Service and Adjustments section of this manual).

### TIRES

- Maintain proper air pressure in all tires (See "PRODUCT SPECIFICATIONS" section of this manual).
- Keep tires free of gasoline, oil, or insect control chemicals which can harm rubber.
- Avoid stumps, stones, deep ruts, sharp objects and other hazards that may cause tire damage.

**NOTE:** To seal tire punctures and prevent flat tires due to slow leaks, tire sealant may be purchased from your local parts dealer. Tire sealant also prevents tire dry rot and corrosion.

### OPERATOR PRESENCE SYSTEM

Be sure operator presence and interlock systems are working properly. If your tractor does not function as described, repair the problem immediately.

- The engine should not start unless the clutch/brake pedal is fully depressed and attachment clutch control is in the disengaged position.
- When the engine is running, any attempt by the operator to leave the seat without first setting the parking brake should shut off the engine.
- When the engine is running and the attachment clutch is engaged, any attempt by the operator to leave the seat should shut off the engine.
- The attachment clutch should never operate unless the operator is in the seat.

### BLADE CARE

For best results mower blades must be kept sharp. Replace bent or damaged blades.

### BLADE REMOVAL

- Raise mower to highest position to allow access to blades.
- Remove hex bolt, lock washer and flat washer securing blade.
- Install new or resharpened blade with trailing edge up towards deck as shown.

**IMPORTANT:** To ensure proper assembly, center hole in blade must align with star on mandrel assembly.

- Reassemble hex bolt, lock washer and flat washer in exact order as shown.
- Tighten bolt securely (27-35 Ft. Lbs. torque).

**IMPORTANT:** Blade bolt is Grade 8 heat treated.

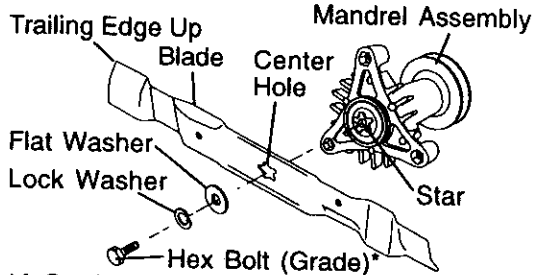

\*A Grade 8 heat treated bolt can be identified by six lines on the bolt head.

### TO SHARPEN BLADE

**NOTE:** We do not recommend sharpening blade - but if you do, be sure the blade is balanced.

Care should be taken to keep the blade balanced. An unbalanced blade will cause excessive vibration and eventual damage to mower and engine.

- The blade can be sharpened with a file or on a grinding wheel. Do not attempt to sharpen while on the mower.
- To check blade balance, you will need a 5/8" diameter steel bolt, pin, or a cone balancer. (When using a cone balancer, follow the instructions supplied with balancer.)

**NOTE:** Do not use a nail for balancing blade. The lobes of the center hole may appear to be centered, but are not.

- Slide blade on to an unthreaded portion of the steel bolt or pin and hold the bolt or pin parallel with the ground. If blade is balanced, it should remain in a horizontal position. If either end of the blade moves downward, sharpen the heavy end until the blade is balanced.

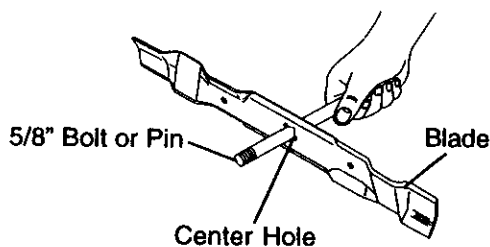

## BATTERY

Your tractor has a battery charging system which is sufficient for normal use. However, periodic charging of the battery with an automotive charger will extend its life.

- Keep battery and terminals clean.
- Keep battery bolts tight.
- Keep small vent holes open.
- Recharge at 6-10 amperes for 1 hour.

**NOTE:** The original equipment battery on your tractor is maintenance free. Do not attempt to open or remove caps or covers. Adding or checking level of electrolyte is not necessary.

## TO CLEAN BATTERY AND TERMINALS

Corrosion and dirt on the battery and terminals can cause the battery to "leak" power.

- Open battery box door.
- Disconnect BLACK battery cable first then RED battery cable and remove battery from tractor.
- Rinse the battery with plain water and dry.
- Clean terminals and battery cable ends with wire brush until bright.
- Coat terminals with grease or petroleum jelly.
- Reinstall battery (See "REPLACING BATTERY" in the SERVICE AND ADJUSTMENTS section of this manual).

## V-BELTS

Check V-belts for deterioration and wear after 100 hours of operation and replace if necessary. The belts are not adjustable. Replace belts if they begin to slip from wear.

## TRANSAXLE COOLING

The transmission fan and cooling fins should be kept clean to assure proper cooling.

Do not attempt to clean fan or transmission while engine is running or while the transmission is hot. To prevent possible damage to seals, do not use high pressure water or steam to clean transaxle.

- Inspect cooling fan to be sure fan blades are intact and clean.
- Inspect cooling fins for dirt, grass clippings and other materials. To prevent damage to seals, do not use compressed air or high pressure sprayer to clean cooling fins.

## TRANSAXLE PUMP FLUID

The transaxle was sealed at the factory and fluid maintenance is not required for the life of the transaxle. Should the transaxle ever leak or require servicing, contact your nearest authorized service center/department.

## ENGINE

### LUBRICATION

Only use high quality detergent oil rated with API service classification SF, SG or SH. Select the oil's SAE viscosity grade according to your expected operating temperature.

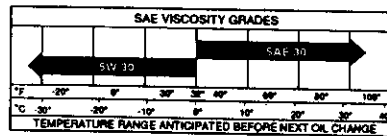

**NOTE:** Although multi-viscosity oils (5W30, 10W30 etc.) improve starting in cold weather, these multi-viscosity oils will result in increased oil consumption when used above 32°F. Check your engine oil level more frequently to avoid possible engine damage from running low on oil.

Change the oil after every 25 hours of operation or at least once a year if the tractor is not used for 25 hours in one year.

Check the crankcase oil level before starting the engine and after each eight (8) hours of operation. Tighten oil fill cap/dipstick securely each time you check the oil level.

### TO CHANGE ENGINE OIL

Determine temperature range expected before oil change. All oil must meet API service classification SF, SG or SH.

- Be sure tractor is on level surface.
- Oil will drain more freely when warm.
- Catch oil in a suitable container.
- Remove oil fill cap/dipstick. Be careful not to allow dirt to enter the engine when changing oil.
- Remove drain plug.
- After oil has drained completely, replace oil drain plug and tighten securely.
- Refill engine with oil through oil fill dipstick tube. Pour slowly. Do not overfill. For approximate capacity see "PRODUCT SPECIFICATIONS" section of this manual.

- Use gauge on oil fill cap/dipstick for checking level. Be sure dipstick cap is tightened securely for accurate reading. Keep oil at "FULL" line on dipstick.

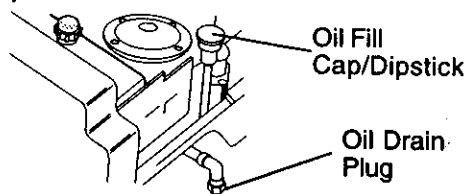

## CLEAN AIR SCREEN

Air screen must be kept free of dirt and chaff to prevent engine damage from overheating. Clean with a wire brush or compressed air to remove dirt and stubborn dried gum fibers.

## ENGINE COOLING FINS

Remove any dust, dirt or oil from engine cooling fins to prevent engine damage from overheating.

- Remove screws from blower housing and lift housing and dipstick tube assembly off engine.
- Cover oil fill opening to prevent entry of dirt.
- Use compressed air or stiff bristle brush to thoroughly clean engine cooling fins.
- To reassemble, reverse above procedure.

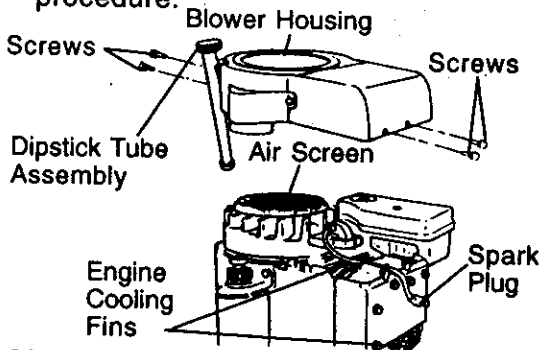

## AIR FILTER

Your engine will not run properly using a dirty air filter. Clean the foam pre-cleaner after every 25 hours of operation or every season. Service paper cartridge every 100 hours of operation or every season, whichever occurs first. Service air cleaner more often under dusty conditions.

- Remove knob(s) and cover.

### TO SERVICE PRE-CLEANER

- Slide foam pre-cleaner off cartridge.
- Wash it in liquid detergent and water.
- Squeeze it dry in a clean cloth.
- Saturate it in engine oil. Wrap it in clean, absorbent cloth and squeeze to remove excess oil.

- If very dirty or damaged, replace pre-cleaner.
- Reinstall pre-cleaner over cartridge.
- Reinstall cover and secure with knob(s).

### TO SERVICE CARTRIDGE

- Remove cartridge nut.
- Carefully remove cartridge to prevent debris from entering carburetor. Clean base carefully to prevent debris from entering carburetor.
- Clean cartridge by tapping gently on flat surface. If very dirty or damaged, replace cartridge.
- Reinstall cartridge, nut, pre-cleaner, cover and secure with knob(s).

**IMPORTANT:** Petroleum solvents, such as kerosene, are not to be used to clean the cartridge. They may cause deterioration of the cartridge. Do not oil cartridge. Do not use pressurized air to clean or dry cartridge.

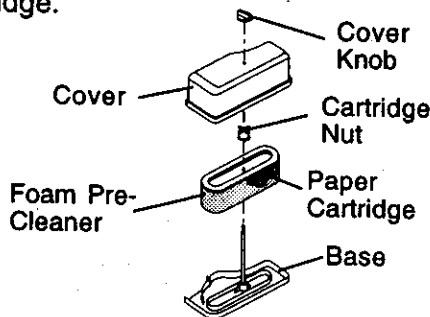

## MUFFLER

Inspect and replace corroded muffler and spark arrester (if equipped) as it could create a fire hazard and/or damage.

## SPARK PLUGS

Replace spark plugs at the beginning of each mowing season or after every 100 hours of operation, whichever occurs first. Spark plug type and gap setting are shown in "PRODUCT SPECIFICATIONS" section of this manual.

## IN-LINE FUEL FILTER

The fuel filter should be replaced once each season. If fuel filter becomes clogged, obstructing fuel flow to carburetor, replacement is required.

- With engine cool, remove filter and plug fuel line sections.
- Place new fuel filter in position in fuel line with arrow pointing towards carburetor.
- Be sure there are no fuel line leaks and clamps are properly positioned.
- Immediately wipe up any spilled gasoline.

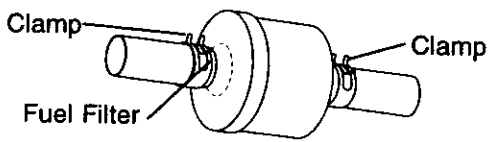

### CLEANING

- Clean engine, battery, seat, finish, etc. of all foreign matter.
- Keep finished surfaces and wheels

free of all gasoline, oil, etc.

- Protect painted surfaces with automotive type wax.

We do not recommend using a garden hose to clean your tractor unless the electrical system, muffler, air filter and carburetor are covered to keep water out. Water in engine can result in a shortened engine life.

## SERVICE AND ADJUSTMENTS

- ⚠ CAUTION:** Before performing any service or adjustments:
- Depress clutch/brake pedal fully and set parking brake.
  - Place motion control lever in neutral (N) position.
  - Place attachment clutch in "DISENGAGED" position.
  - Turn ignition key "OFF" and remove key.
  - Make sure the blades and all moving parts have completely stopped.
  - Disconnect spark plug wire from spark plug and place wire where it cannot come in contact with plug. Tractor

### TO REMOVE MOWER

Mower will be easier to remove from the right side of tractor.

- Place attachment clutch in "DISENGAGED" position.
- Move attachment lift lever forward to lower mower to its lowest position.
- Roll belt off engine pulley.
- Remove small retainer spring, and lift clutch spring off pulley bolt.
- Remove large retainer spring, slide collar off and push housing guide out of bracket.
- Disconnect anti-swaybar from chassis bracket by removing retainer spring.
- Disconnect suspension arms from rear deck brackets by removing retainer springs.
- Disconnect front links from deck by removing retainer springs.
- Raise lift lever to raise suspension

arms. Slide mower out from under tractor.

**IMPORTANT:** If an attachment other than the mower deck is to be mounted on the tractor, remove the front links and hook the clutch spring onto square hole in frame.

### TO INSTALL MOWER

- Raise attachment lift lever to its highest position.
- Slide mower under tractor with discharge guard to right side of tractor.
- Lower lift lever to its lowest position.
- Install mower in reverse order of removal instructions.

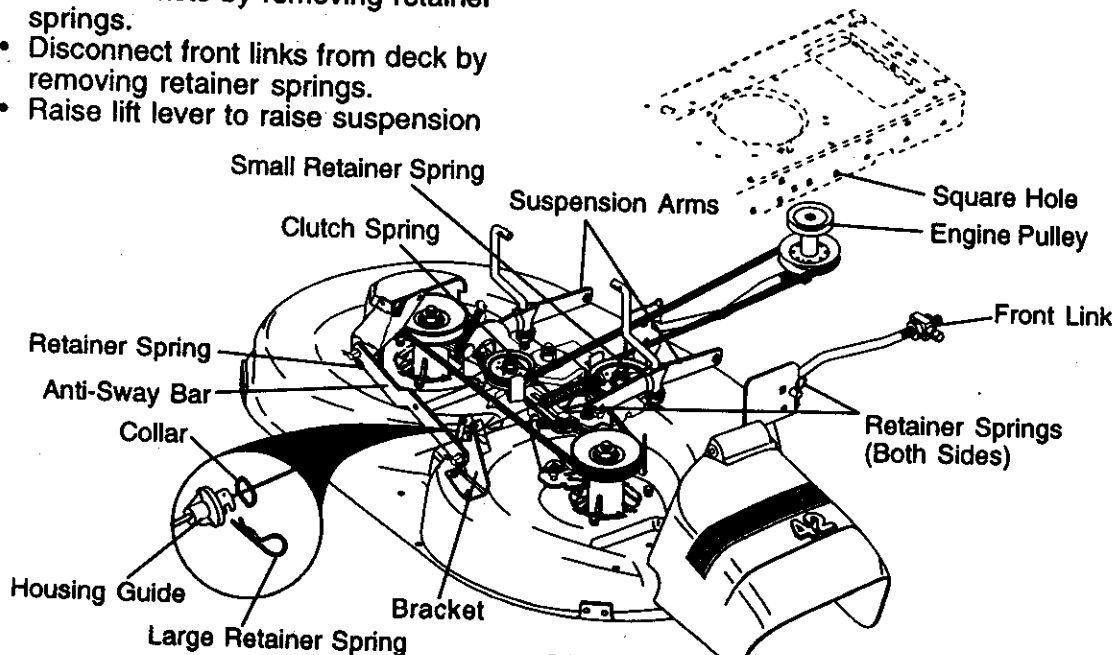

## TO LEVEL MOWER HOUSING

Adjust the mower while tractor is parked on level ground or driveway. Make sure tires are properly inflated (See "PRODUCT SPECIFICATIONS" section of this manual). If tires are over or underinflated, you will not properly adjust your mower.

### SIDE-TO-SIDE ADJUSTMENT

- Raise mower to its highest position.
- At the midpoint of both sides of mower, measure height from bottom edge of mower to ground. Distance "A" on both sides of mower should be the same or within 1/4" of each other.
- If adjustment is necessary, make adjustment on one side of mower only.
- To raise one side of mower, tighten lift link adjustment nut on that side.
- To lower one side of mower, loosen lift link adjustment nut on that side.

**NOTE:** Each full turn of adjustment nut will change mower height about 1/8".

- Recheck measurements after adjusting.

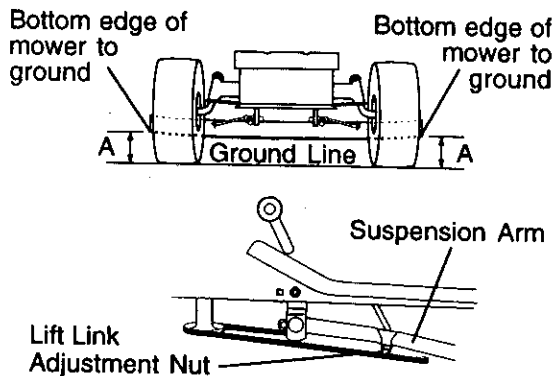

### FRONT-TO-BACK ADJUSTMENT

**IMPORTANT:** Deck must be level side-to-side. If the following front-to-back adjustment is necessary, be sure to adjust both front links equally so mower will stay level side-to-side.

To obtain the best cutting results, the mower housing should be adjusted so that the front is approximately 1/8" to 1/2" lower than the rear when the mower is in its highest position.

Check adjustment on right side of tractor. Measure distance "D" directly in front and behind the mandrel at bottom edge of mower housing as shown.

- Before making any necessary adjustments, check that both front links are equal in length. Both links should be approximately 10-3/8".
- If links are not equal in length, adjust one link to same length as other link.
- To lower front of mower loosen nut "E" on both front links an equal number of turns.
- When distance "D" is 1/8" to 1/2" lower at front than rear, tighten nuts "F" against trunnion on both front links.
- To raise front of mower, loosen nut "F" from trunnion on both front links. Tighten nut "E" on both front links an equal number of turns.
- When distance "D" is 1/8" to 1/2" lower at front than rear, tighten nut "F" against trunnion on both front links.
- Recheck side-to-side adjustment.

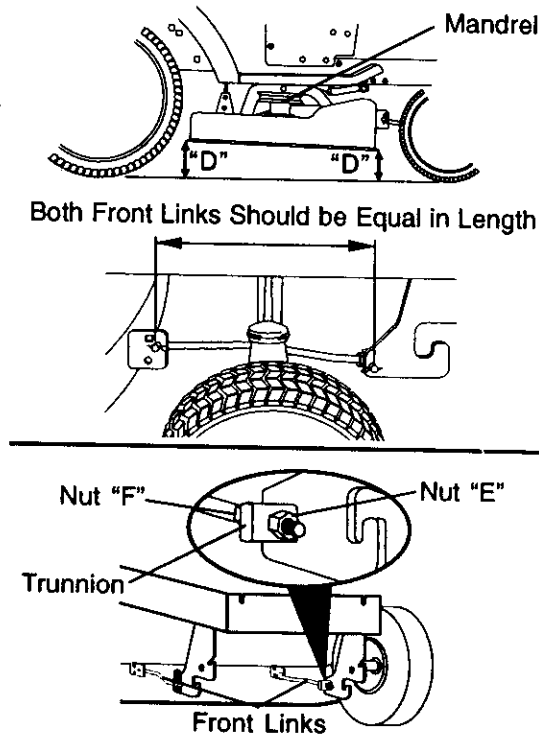

## TO REPLACE MOWER BLADE DRIVE BELT

The mower blade drive belt may be replaced without tools. Park the tractor on level surface. Engage parking brake.

### BELT REMOVAL -

- Remove mower from tractor (See "TO REMOVE MOWER" in this section of this manual).
- Work belt off both mandrel pulleys and idler pulleys.
- Pull belt away from mower.

### BELT INSTALLATION -

- Install new belt in reverse order of removal.
- Make sure belt is in all pulley grooves and inside all belt guides.
- Install mower in reverse order of removal instructions.

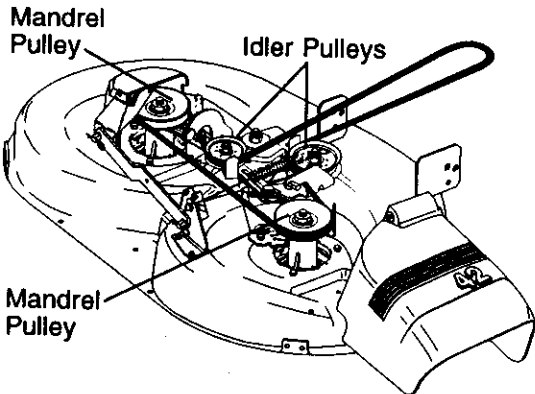

## TO ADJUST BRAKE

Your tractor is equipped with an adjustable brake system which is mounted on the side of the transaxle.

If tractor requires more than six (6) feet stopping distance at high speed in highest gear, then brake must be adjusted.

- Depress clutch/brake pedal and engage parking brake.
- Measure distance between brake operating arm and nut "A" on brake rod.
- If distance is other than 1-9/16", loosen jam nut and turn nut "A" until distance becomes 1-9/16". Retighten jam nut against nut "A".
- Road test tractor for proper stopping distance as stated above. Readjust if necessary. If stopping distance is still greater than six (6) feet in highest gear, further maintenance is necessary. Contact your nearest authorized service center/department.

With Parking Brake "Engaged"

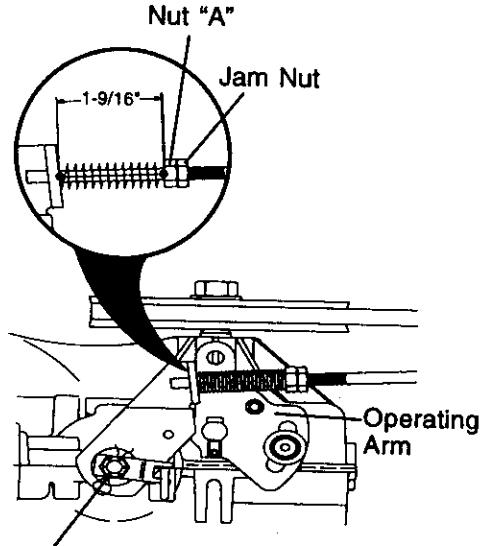

Do Not touch this nut. If further brake adjustment is necessary contact your nearest authorized service center/department

## TO REPLACE MOTION DRIVE BELT

Park the tractor on level surface. Engage parking brake. For assistance, there is a belt installation guide decal on bottom side of left footrest.

- Remove mower (See "TO REMOVE MOWER" in this section of this manual.)
- Remove belt from stationary idler and clutching idler.
- Pull belt slack toward rear of tractor. Carefully remove belt upwards from transmission input pulley and over cooling fan blades.
- Pull belt toward front of tractor and remove downward from around engine pulley.
- Install new belt by reversing above procedure.

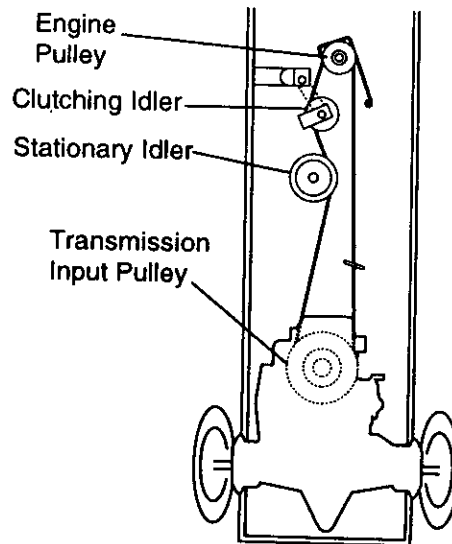

## TRANSAXLE MOTION CONTROL LEVER NEUTRAL ADJUSTMENT

The motion control lever has been preset at the factory and adjustment should not be necessary.

- Loosen adjustment bolt in front of the right rear wheel, and lightly tighten.
- Start engine and move motion control lever until tractor does not move forward or backward.
- Hold motion control lever in that position and turn engine off.
- While holding motion control lever in place, loosen the adjustment bolt.
- Move motion control lever to the neutral (N) (lock gate) position.
- Tighten adjustment bolt securely.

**NOTE:** If additional clearance is needed to get to adjustment bolt, move mower deck height to the lowest position.

After above adjustment is made, if the tractor still creeps forward or backward while motion control lever is in neutral position, follow these steps:

- Loosen the adjustment bolt.
- Move the motion control lever 1/4 to 1/2 inch in the direction it is trying to creep.
- Tighten adjustment bolt securely.
- Start engine and test.
- If tractor still creeps, repeat above steps until satisfied.

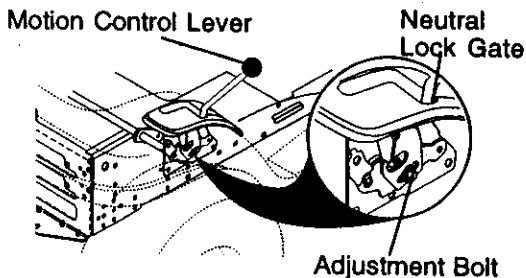

## TO ADJUST STEERING WHEEL ALIGNMENT

If steering wheel crossbars are not horizontal (left to right) when wheels are positioned straight forward, remove steering wheel and reassemble per instructions in the Assembly section of this manual.

## FRONT WHEEL TOE-IN/CAMBER

The front wheel toe-in and camber are not adjustable on your tractor. If damage has occurred to affect the front wheel toe-in or camber, contact your nearest authorized service center/department.

## TO REMOVE WHEEL FOR REPAIRS

- Block up axle securely.
- Remove axle cover, retaining ring and washers to allow wheel removal (rear wheel contains a square key - Do not lose).
- Repair tire and reassemble.
- On rear wheels only: align grooves in rear wheel hub and axle. Insert square key.
- Replace washers and snap retaining ring securely in axle groove.
- Replace axle cover.

**NOTE:** To seal tire punctures and prevent flat tires due to slow leaks, tire sealant may be purchased from your local parts dealer. Tire sealant also prevents tire dry rot and corrosion.

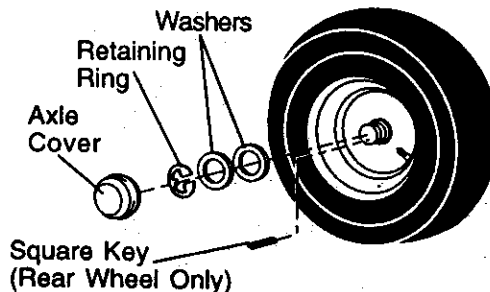

## TO START ENGINE WITH A WEAK BATTERY

**CAUTION:** Lead-acid batteries generate explosive gases. Keep sparks, flame and smoking materials away from batteries. Always wear eye protection when around batteries.

If your battery is too weak to start the engine, it should be recharged. (See "BATTERY" in the MAINTENANCE section of this manual).

If "jumper cables" are used for emergency starting, follow this procedure:

**IMPORTANT:** Your tractor is equipped with a 12 volt negative grounded system. The other vehicle must also be a 12 volt negative grounded system. Do not use your tractor battery to start other vehicles.



### TO ATTACH JUMPER CABLES -

- Connect each end of the RED cable to the POSITIVE (+) terminal of each battery, taking care not to short against chassis.
- Connect one end of the BLACK cable to the NEGATIVE (-) terminal of fully charged battery.
- Connect the other end of the BLACK cable to good CHASSIS GROUND, away from fuel tank and battery.

### TO REMOVE CABLES, REVERSE ORDER -

- BLACK cable first from chassis and then from the fully charged battery.
- RED cable last from both batteries.

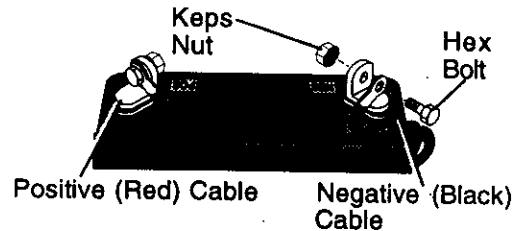
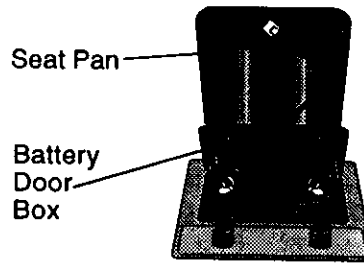

Positive Terminal      Negative Terminal

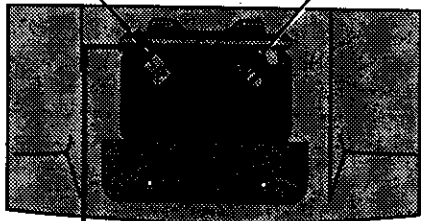

Chassis      Cables      Charged Battery

Positive Terminal      Negative Terminal

### REPLACING BATTERY

**⚠ CAUTION:** Do not short battery terminals by allowing a wrench or any other object to contact both terminals at the same time. Before connecting battery, remove metal bracelets, wristwatch bands, rings, etc. Positive terminal must be connected first to prevent sparking from accidental grounding.

- Lift seat pan to raised position and open battery box door.
- Disconnect BLACK battery cable first then RED battery cable and carefully remove battery from tractor.
- Install new battery with terminals in same position as old battery.
- First connect RED battery cable to positive (+) terminal with hex bolt and nut as shown. Tighten securely.
- Connect BLACK grounding cable to negative (-) terminal with remaining hex bolt and nut. Tighten securely.
- Close battery box door.

### TO REPLACE HEADLIGHT BULB

- Raise hood.
- Pull bulb holder out of the hole in the backside of the grill.
- Replace bulb in holder and push bulb holder securely back into the hole in the backside of the grill.
- Close hood.

### INTERLOCKS AND RELAYS

Loose or damaged wiring may cause your tractor to run poorly, stop running, or prevent it from starting.

- Check wiring. See electrical wiring diagram in the Repair Parts section.

### TO REPLACE FUSE

Replace with 15 amp automotive-type plug-in fuse. The fuse holder is located behind the dash.

### TO REMOVE HOOD AND GRILL ASSEMBLY

- Raise hood.
- Unsnap headlight wire connector.
- Stand in front of tractor. Grasp hood at sides, tilt toward engine and lift off of tractor.
- To replace, reverse above procedure.

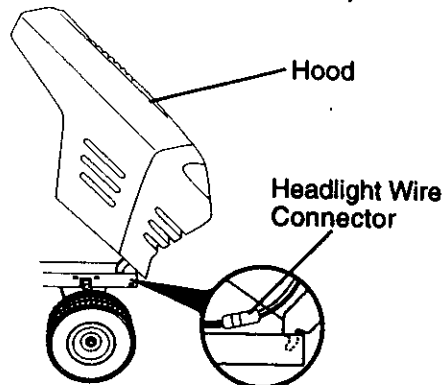

## ENGINE

Maintenance, repair, or replacement of the emission control devices and systems, which are being done at the customer's expense, may be performed by any non-road engine repair establishment or individual. Warranty repairs must be performed by an authorized engine manufacturer's service outlet.

### TO ADJUST THROTTLE CONTROL CABLE

The throttle control has been preset at the factory and adjustment should not be necessary. Check adjustment as described below before loosening cable. If adjustment is necessary, proceed as follows:

- With engine not running, move throttle control lever from slow to choke position. Slowly move lever from choke to fast position.
- Check that holes "A" in governor control lever and hole in governor plate line-up. If holes "A" are not aligned, loosen clamp screw and move throttle cable until holes are aligned. Tighten clamp screw securely.

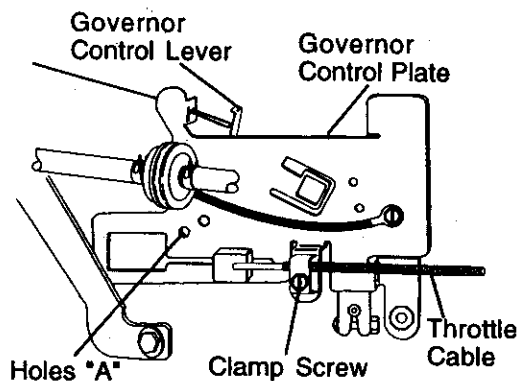

### TO ADJUST CARBURETOR

**NOTE:** The carburetor on this engine is low emission. It is equipped with an idle fuel adjusting needle with a limiter cap, which allows some adjustment within the limits allowed by the cap. Do not attempt to remove the limiter cap. The limiter cap cannot be removed without breaking the adjusting needle.

The carburetor has been preset at the factory and adjustment should not be necessary. However, minor adjustment may be required to compensate for differences in fuel, temperature, altitude or load. If the carburetor does need adjustment, proceed as follows:

In general, turning idle mixture valve in (clockwise) decreases the supply of fuel to the engine giving a leaner fuel/air mixture. Turning the idle mixture valve out (counterclockwise) increases the supply of fuel to the engine giving a richer fuel/air mixture.

**IMPORTANT:** Damage to the needle valve and the seat in carburetor may result if screw is turned in too tight.

### PRELIMINARY SETTING -

- Air cleaner assembly must be assembled to the carburetor when making carburetor adjustments.
- Be sure the throttle control cable is adjusted properly (see above).

### FINAL SETTING -

- Start engine and allow to warm for five minutes. Make final adjustments with engine running and shift/motion control lever in neutral (N) position.
- Move throttle control lever to slow position. With finger, rotate and hold throttle lever against idle speed screw. Turn idle speed screw to attain 1750 RPM.
- While still holding throttle lever against idle speed screw, turn idle mixture valve full travel clockwise then counterclockwise until engine runs rough. Turn valve to a point midway between those two positions. Release throttle lever.

### ACCELERATION TEST -

- Move throttle control lever from slow to fast position. If engine hesitates or dies, turn idle mixture valve **out** (counterclockwise) 1/8 turn. Repeat test and continue to adjust, if necessary, until engine accelerates smoothly.

High speed stop is factory adjusted. Do not adjust - damage may result.

**IMPORTANT:** Never tamper with the engine governor, which is factory set for proper engine speed. Overspeeding the engine above the factory high speed setting can be dangerous. If you think the engine-governed high speed needs adjusting, contact your nearest authorized service center/department, which has proper equipment and experience to make any necessary adjustments.

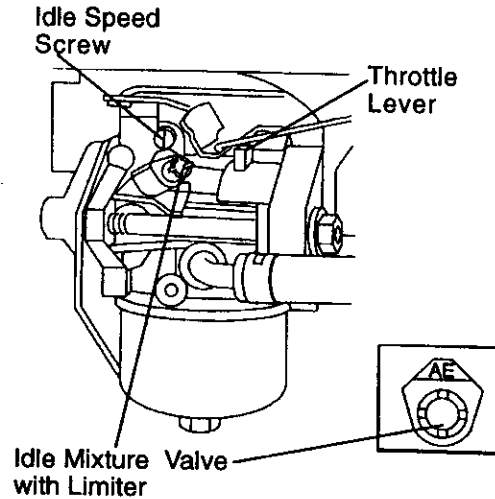

# STORAGE

Immediately prepare your tractor for storage at the end of the season or if the tractor will not be used for 30 days or more.

**CAUTION:** Never store the tractor with gasoline in the tank inside a building where fumes may reach an open flame or spark. Allow the engine to cool before storing in any enclosure.

## TRACTOR

Remove mower from tractor for winter storage. When mower is to be stored for a period of time, clean it thoroughly, remove all dirt, grease, leaves, etc. Store in a clean, dry area.

- Clean entire tractor (See "CLEANING" in the Maintenance section of this manual).
- Inspect and replace belts, if necessary (See belt replacement instructions in the Service and Adjustments section of this manual).
- Lubricate as shown in the Maintenance section of this manual.
- Be sure that all nuts, bolts and screws are securely fastened. Inspect moving parts for damage, breakage and wear. Replace if necessary.
- Touch up all rusted or chipped paint surfaces; sand lightly before painting.

## BATTERY

- Fully charge the battery for storage.
- After a period of time in storage, battery may require recharging.
- To help prevent corrosion and power leakage during long periods of storage, battery cables should be disconnected and battery cleaned thoroughly (see "TO CLEAN BATTERY AND TERMINALS" in the Maintenance section of this manual).
- After cleaning, leave cables disconnected and place cables where they cannot come in contact with battery terminals.
- If battery is removed from tractor for storage, do not store battery directly on concrete or damp surfaces.

## ENGINE

### FUEL SYSTEM

**IMPORTANT:** It is important to prevent gum deposits from forming in essential fuel system parts such as carburetor, fuel filter, fuel hose, or tank during storage. Also, experience indicates that alcohol blended fuels (called gasohol or using

ethanol or methanol) can attract moisture which leads to separation and formation of acids during storage. Acidic gas can damage the fuel system of an engine while in storage.

- Drain the fuel tank.
- Start the engine and let it run until the fuel lines and carburetor are empty.
- Never use engine or carburetor cleaner products in the fuel tank or permanent damage may occur.
- Use fresh fuel next season.

**NOTE:** Fuel stabilizer is an acceptable alternative in minimizing the formation of fuel gum deposits during storage. Add stabilizer to gasoline in fuel tank or storage container. Always follow the mix ratio found on stabilizer container. Run engine at least 10 minutes after adding stabilizer to allow the stabilizer to reach the carburetor. Do not drain the gas tank and carburetor if using fuel stabilizer.

### ENGINE OIL

Drain oil (with engine warm) and replace with clean engine oil. (See "ENGINE" in the Maintenance section of this manual).

### CYLINDER(S)

- Remove spark plug(s).
- Pour one ounce of oil through spark plug hole(s) into cylinder(s).
- Turn ignition key to "START" position for a few seconds to distribute oil.
- Replace with new spark plug(s).

### OTHER

- Do not store gasoline from one season to another.
- Replace your gasoline can if your can starts to rust. Rust and/or dirt in your gasoline will cause problems.
- If possible, store your tractor indoors and cover it to give protection from dust and dirt.
- Cover your tractor with a suitable protective cover that does not retain moisture. Do not use plastic. Plastic cannot breathe which allows condensation to form and will cause your tractor to rust.

**IMPORTANT:** Never cover tractor while engine and exhaust areas are still warm.

## TROUBLESHOOTING CHART

| PROBLEM                                 | CAUSE                                                                                                                                                                                                                                                                                                                                                                                            | CORRECTION                                                                                                                                                                                                                                                                                                                                                                                                                                                                                                                                |
|-----------------------------------------|--------------------------------------------------------------------------------------------------------------------------------------------------------------------------------------------------------------------------------------------------------------------------------------------------------------------------------------------------------------------------------------------------|-------------------------------------------------------------------------------------------------------------------------------------------------------------------------------------------------------------------------------------------------------------------------------------------------------------------------------------------------------------------------------------------------------------------------------------------------------------------------------------------------------------------------------------------|
| <b>Will not start</b>                   | <ul style="list-style-type: none"> <li>• Out of fuel.</li> <li>• Engine not "CHOKED" properly.</li> <li>• Engine flooded.</li> <br/> <li>• Bad spark plug.</li> <li>• Dirty air filter.</li> <li>• Dirty fuel filter.</li> <li>• Water in fuel.</li> <br/> <li>• Loose or damaged wiring.</li> <li>• Carburetor out of adjustment.</li> <li>• Engine valves out of adjustment.</li> </ul>        | <ul style="list-style-type: none"> <li>• Fill fuel tank.</li> <li>• See "TO START ENGINE" in Operation section.</li> <li>• Wait several minutes before attempting to start.</li> <li>• Replace spark plug.</li> <li>• Clean/replace air filter.</li> <li>• Replace fuel filter.</li> <li>• Drain fuel tank and carburetor, refill tank with fresh gasoline and replace fuel filter.</li> <li>• Check all wiring.</li> <li>• See "To Adjust Carburetor" in section.</li> <li>• Contact an authorized service center/department.</li> </ul> |
| <b>Hard to start</b>                    | <ul style="list-style-type: none"> <li>• Dirty air filter.</li> <li>• Bad spark plug.</li> <li>• Weak or dead battery.</li> <li>• Dirty fuel filter.</li> <li>• Stale or dirty fuel.</li> <br/> <li>• Loose or damaged wiring.</li> <li>• Carburetor out of adjustment.</li> <br/> <li>• Engine valves out of adjustment.</li> </ul>                                                             | <ul style="list-style-type: none"> <li>• Clean/replace air filter.</li> <li>• Replace spark plug.</li> <li>• Recharge or replace battery.</li> <li>• Replace fuel filter.</li> <li>• Drain fuel tank and refill with fresh gasoline.</li> <li>• Check all wiring.</li> <li>• See "To Adjust Carburetor" in Service Adjustments section.</li> <li>• Contact an authorized service center/department.</li> </ul>                                                                                                                            |
| <b>Engine will not turn over</b>        | <ul style="list-style-type: none"> <li>• Clutch/brake pedal not depressed</li> <li>• Attachment clutch is engaged.</li> <li>• Weak or dead battery.</li> <li>• Blown fuse.</li> <li>• Corroded battery terminals.</li> <li>• Loose or damaged wiring.</li> <li>• Faulty ignition switch.</li> <li>• Faulty solenoid or starter.</li> <br/> <li>• Faulty operator presence switch(es).</li> </ul> | <ul style="list-style-type: none"> <li>• Depress clutch/brake pedal.</li> <li>• Disengage attachment clutch.</li> <li>• Recharge or replace battery.</li> <li>• Replace fuse.</li> <li>• Clean battery terminals.</li> <li>• Check all wiring.</li> <li>• Check/replace ignition switch.</li> <li>• Check/replace solenoid or starter.</li> <li>• Contact an authorized service center/department.</li> </ul>                                                                                                                             |
| <b>Engine clicks but will not start</b> | <ul style="list-style-type: none"> <li>• Weak or dead battery.</li> <li>• Corroded battery terminals.</li> <li>• Loose or damaged wiring.</li> <li>• Faulty solenoid or starter.</li> </ul>                                                                                                                                                                                                      | <ul style="list-style-type: none"> <li>• Recharge or replace battery.</li> <li>• Clean battery terminals.</li> <li>• Check all wiring.</li> <li>• Check/replace solenoid or starter.</li> </ul>                                                                                                                                                                                                                                                                                                                                           |

## TROUBLESHOOTING CHART

| PROBLEM                                                                                 | CAUSE                                                                                                                                                                                                                                                                                                                                                                                                                                                                                                                                                                                                                                          | CORRECTION                                                                                                                                                                                                                                                                                                                                                                                                                                                                                                                                                                                                                                                                                                                                                                                                    |
|-----------------------------------------------------------------------------------------|------------------------------------------------------------------------------------------------------------------------------------------------------------------------------------------------------------------------------------------------------------------------------------------------------------------------------------------------------------------------------------------------------------------------------------------------------------------------------------------------------------------------------------------------------------------------------------------------------------------------------------------------|---------------------------------------------------------------------------------------------------------------------------------------------------------------------------------------------------------------------------------------------------------------------------------------------------------------------------------------------------------------------------------------------------------------------------------------------------------------------------------------------------------------------------------------------------------------------------------------------------------------------------------------------------------------------------------------------------------------------------------------------------------------------------------------------------------------|
| <b>Loss of power</b>                                                                    | <ul style="list-style-type: none"> <li>• Cutting too much grass/too fast.</li> <li>• Throttle in "CHOKE" position.</li> <li>• Build-up of grass, leaves and trash under mower.</li> <li>• Dirty air filter.</li> <li>• Low oil level/dirty oil.</li> <li>• Faulty spark plug.</li> <br/> <li>• Dirty fuel filter.</li> <li>• Stale or dirty fuel.</li> <br/> <li>• Water in fuel.</li> <br/> <li>• Spark plug wire loose.</li> <li>• Dirty engine air screen/fins.</li> <li>• Dirty/clogged muffler.</li> <li>• Loose or damaged wiring.</li> <li>• Carburetor out of adjustment.</li> <br/> <li>• Engine valves out of adjustment.</li> </ul> | <ul style="list-style-type: none"> <li>• Set in "Higher Cut" position/ reduce speed.</li> <li>• Adjust throttle control.</li> <br/> <li>• Clean underside of mower housing.</li> <li>• Clean/replace air filter.</li> <li>• Check oil level/change oil.</li> <li>• Clean and regap or change spark plug.</li> <li>• Replace fuel filter.</li> <li>• Drain fuel tank and refill with fresh gasoline.</li> <li>• Drain fuel tank and carburetor, refill tank with fresh gasoline and replace fuel filter.</li> <li>• Connect and tighten spark plug wire.</li> <li>• Clean engine air screen/ fins.</li> <li>• Clean/replace muffler.</li> <li>• Check all wiring.</li> <li>• See "To Adjust Carburetor" in Service Adjustments section.</li> <li>• Contact an authorized service center/department.</li> </ul> |
| <b>Excessive vibration</b>                                                              | <ul style="list-style-type: none"> <li>• Worn, bent or loose blade.</li> <li>• Bent blade mandrel.</li> <li>• Loose/damaged part(s).</li> </ul>                                                                                                                                                                                                                                                                                                                                                                                                                                                                                                | <ul style="list-style-type: none"> <li>• Replace blade.</li> <li>• Tighten blade bolt.</li> <li>• Replace blade mandrel.</li> <li>• Tighten loose part(s).</li> <li>• Replace damaged parts.</li> </ul>                                                                                                                                                                                                                                                                                                                                                                                                                                                                                                                                                                                                       |
| <b>Engine continues to run when operator leaves seat with attachment clutch engaged</b> | <ul style="list-style-type: none"> <li>• Faulty operator-safety presence control system.</li> </ul>                                                                                                                                                                                                                                                                                                                                                                                                                                                                                                                                            | <ul style="list-style-type: none"> <li>• Check wiring, switches and connections. If not corrected, contact an authorized service center/department.</li> </ul>                                                                                                                                                                                                                                                                                                                                                                                                                                                                                                                                                                                                                                                |
| <b>Poor cut - uneven</b>                                                                | <ul style="list-style-type: none"> <li>• Worn, bent or loose blade.</li> <li>• Mower deck not level.</li> <li>• Buildup of grass, leaves, and trash under mower.</li> <li>• Bent blade mandrel.</li> <li>• Clogged mower deck vent from build-up of grass, leaves, and trash around mandrels.</li> </ul>                                                                                                                                                                                                                                                                                                                                       | <ul style="list-style-type: none"> <li>• Replace blade. Tighten blade bolt.</li> <li>• Level mower deck.</li> <li>• Clean underside of mower housing.</li> <li>• Replace blade mandrel.</li> <li>• Clean around mandrels to open vent holes.</li> </ul>                                                                                                                                                                                                                                                                                                                                                                                                                                                                                                                                                       |

## TROUBLESHOOTING CHART

| PROBLEM                                      | CAUSE                                                                                                                                                                                                                                                                                                                                                                                                                                                                                                                       | CORRECTION                                                                                                                                                                                                                                                                                                                                                                                                                                                                                                                                                            |
|----------------------------------------------|-----------------------------------------------------------------------------------------------------------------------------------------------------------------------------------------------------------------------------------------------------------------------------------------------------------------------------------------------------------------------------------------------------------------------------------------------------------------------------------------------------------------------------|-----------------------------------------------------------------------------------------------------------------------------------------------------------------------------------------------------------------------------------------------------------------------------------------------------------------------------------------------------------------------------------------------------------------------------------------------------------------------------------------------------------------------------------------------------------------------|
| Mower blades will not rotate                 | <ul style="list-style-type: none"> <li>• Obstruction in clutch mechanism.</li> <li>• Worn/damaged mower drive belt.</li> <li>• Frozen idler pulley.</li> <li>• Frozen blade mandrel.</li> </ul>                                                                                                                                                                                                                                                                                                                             | <ul style="list-style-type: none"> <li>• Remove obstruction.</li> <li>• Replace mower drive belt.</li> <li>• Replace idler pulley.</li> <li>• Replace blade mandrel.</li> </ul>                                                                                                                                                                                                                                                                                                                                                                                       |
| Poor grass discharge                         | <ul style="list-style-type: none"> <li>• Engine speed too slow.</li> <li>• Travel speed too fast.</li> <li>• Wet grass.</li> <li>• Mower deck not level.</li> <li>• Low/uneven tire air pressure.</li> <li>• Worn, bent or loose blade.</li> <li>• Buildup of grass, leaves and trash under mower.</li> <li>• Mower drive belt worn.</li> <li>• Blades improperly installed.</li> <li>• Improper blades used.</li> <li>• Clogged mower deck vent holes from buildup of grass, leaves, and trash around mandrels.</li> </ul> | <ul style="list-style-type: none"> <li>• Place throttle control in "FAST" position.</li> <li>• Shift to slower speed.</li> <li>• Allow grass to dry before mowing.</li> <li>• Level mower deck.</li> <li>• Check tires for proper air pressure.</li> <li>• Replace/sharpen blade.</li> <li>• Tighten blade bolt.</li> <li>• Clean underside of mower housing.</li> <li>• Replace mower drive belt.</li> <li>• Reinstall blades sharp edge down.</li> <li>• Replace with blades listed in this manual.</li> <li>• Clean around mandrels to open vent holes.</li> </ul> |
| Headlight(s) not working (if so equipped)    | <ul style="list-style-type: none"> <li>• Switch is "OFF".</li> <li>• Bulb(s) burned out.</li> <li>• Faulty light switch.</li> <li>• Loose or damaged wiring.</li> <li>• Blown fuse.</li> </ul>                                                                                                                                                                                                                                                                                                                              | <ul style="list-style-type: none"> <li>• Turn switch "ON".</li> <li>• Replace bulb(s).</li> <li>• Check/replace light switch.</li> <li>• Check wiring and connections.</li> <li>• Replace fuse.</li> </ul>                                                                                                                                                                                                                                                                                                                                                            |
| Battery will not charge                      | <ul style="list-style-type: none"> <li>• Bad battery cell(s).</li> <li>• Poor cable connections.</li> <li>• Faulty regulator (if so equipped).</li> <li>• Faulty alternator.</li> </ul>                                                                                                                                                                                                                                                                                                                                     | <ul style="list-style-type: none"> <li>• Replace battery.</li> <li>• Check/clean all connections.</li> <li>• Replace regulator.</li> <li>• Replace alternator.</li> </ul>                                                                                                                                                                                                                                                                                                                                                                                             |
| Loss of drive                                | <ul style="list-style-type: none"> <li>• Freewheel control in "disengaged" position.</li> <li>• Motion drive belt worn, damaged, or broken.</li> <li>• Air trapped in transmission during shipment or servicing.</li> </ul>                                                                                                                                                                                                                                                                                                 | <ul style="list-style-type: none"> <li>• Place freewheel control in "engaged" position.</li> <li>• Replace motion drive belt.</li> <li>• Purge transmission.</li> </ul>                                                                                                                                                                                                                                                                                                                                                                                               |
| Engine "backfires" when turning engine "OFF" | <ul style="list-style-type: none"> <li>• Engine throttle control not set at "SLOW" position for 30 seconds stopping engine.</li> </ul>                                                                                                                                                                                                                                                                                                                                                                                      | <ul style="list-style-type: none"> <li>• Move throttle control to "SLOW" position and allow to idle for 30 seconds before stopping engine.</li> </ul>                                                                                                                                                                                                                                                                                                                                                                                                                 |





# TRACTOR -- MODEL NUMBER 917.270740

## SCHEMATIC

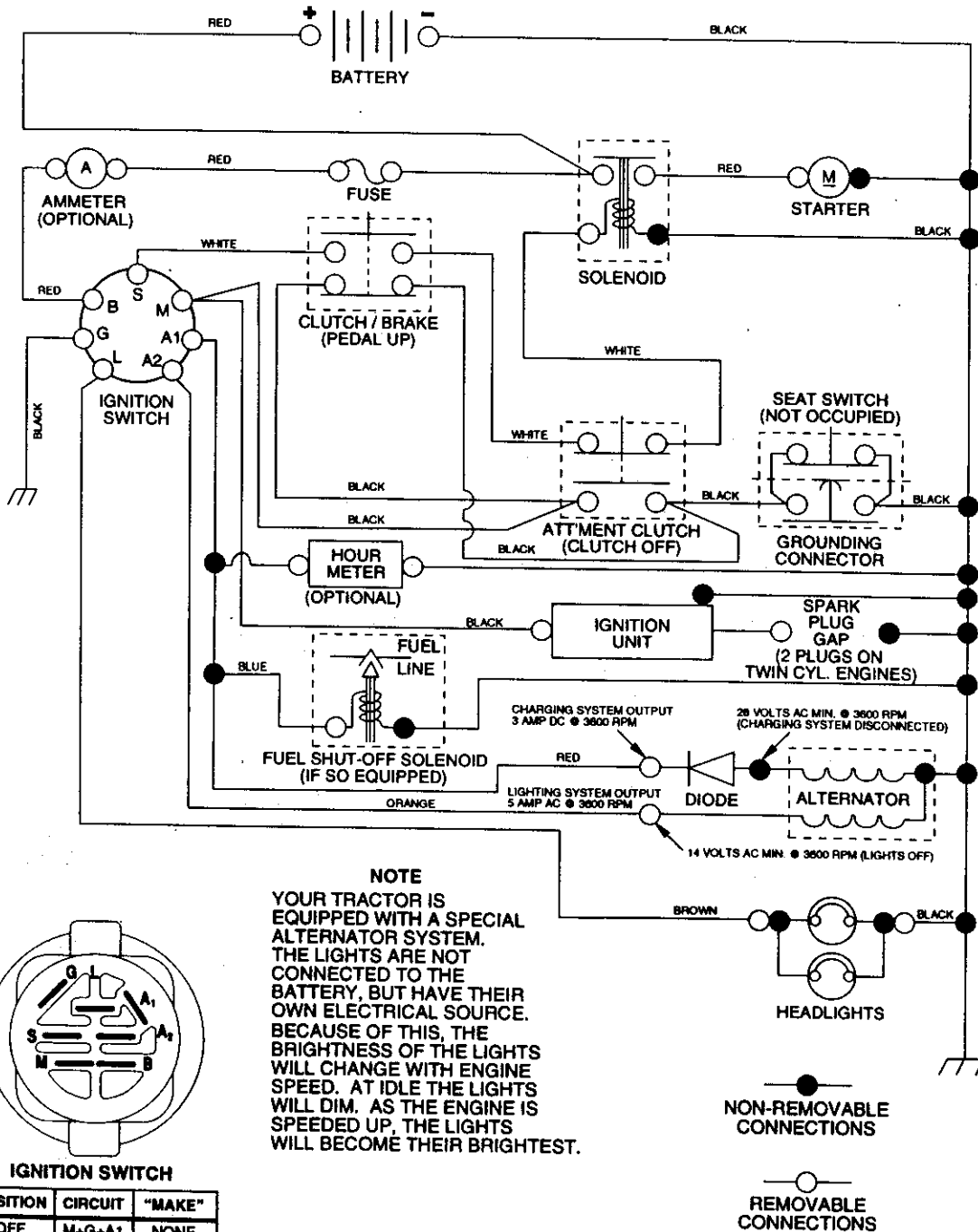

# REPAIR PARTS

TRACTOR -- MODEL NUMBER 917.270740

## ELECTRICAL

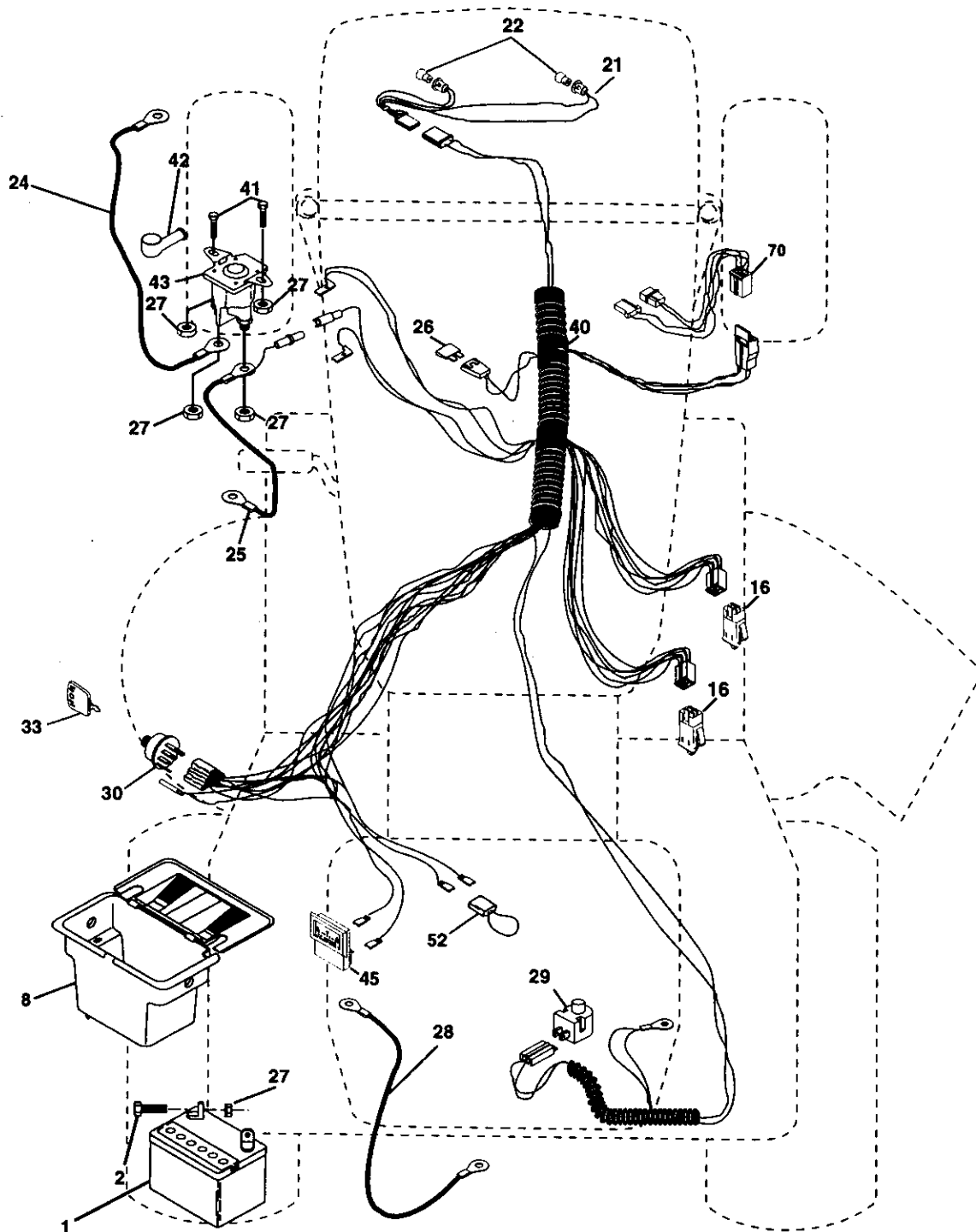

# TRACTOR -- MODEL NUMBER 917.270740

## ELECTRICAL

| KEY NO. | PART NO. | DESCRIPTION                             |
|---------|----------|-----------------------------------------|
| 1       | 144925   | Battery                                 |
| 2       | 74760412 | Bolt, Hex Head 1/4-20 unc x 3/4         |
| 8       | 156417   | Case, Battery Mech Hinge                |
| 16      | 153664   | Switch, Ignition                        |
| 21      | 166182   | Harness, Light Socket (Includes 4152J)  |
| 22      | 4152J    | Bulb, Light                             |
| 24      | 4799J    | Cable, Battery, 6 Gauge, Red, 11"       |
| 25      | 146147   | Cable, Battery, 6 Gauge, Red, W/16 Wire |
| 26      | 166180   | Fuse, 15 Amp                            |
| 27      | 73510400 | Nut Keps Hex1/4-20 Unc                  |
| 28      | 4207J    | Cable, Ground, 6 Gauge, Black, 12"      |
| 29      | 121305X  | Switch, Plunger                         |
| 30      | 163968   | Switch, Ignition                        |
| 33      | 140403   | Key, Ignition                           |
| 40      | 170217   | Harness, Ignition                       |
| 41      | 71110408 | Bolt, Hex Head, Fin. 1/4-20 x 1/2       |
| 42      | 131563   | Cover, Terminal, Red                    |
| 43      | 145673   | Solenoid                                |
| 45      | 121433X  | Ammeter Rectangular                     |
| 52      | 141940   | Protection Wire Loop                    |
| 70      | 170243   | Harness Engine                          |

**NOTE:** All component dimensions given in U.S. inches  
1 inch = 25.4 mm

**TRACTOR -- MODEL NUMBER 917.270740**  
**CHASSIS AND ENCLOSURES**

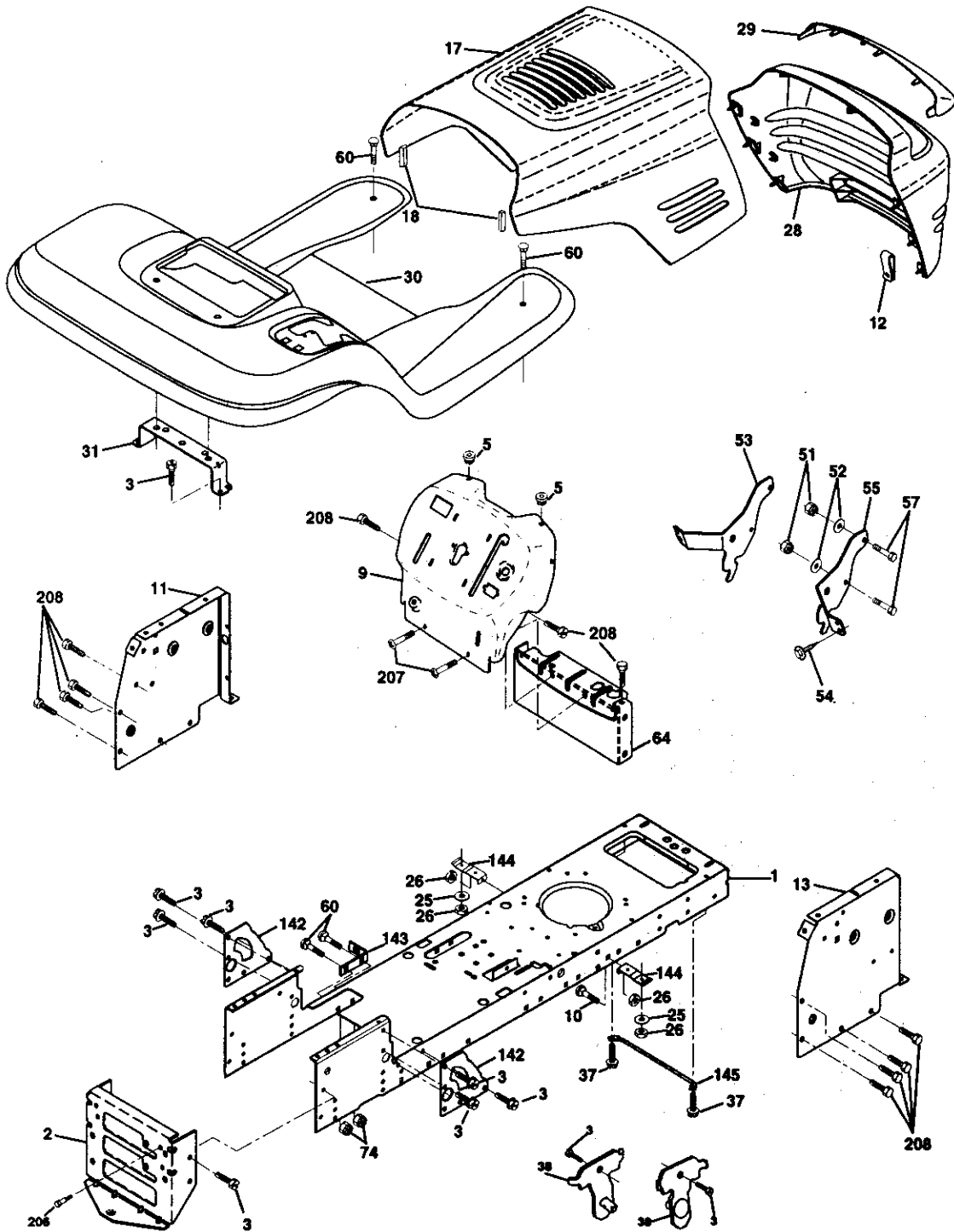

## TRACTOR--MODEL NUMBER 917.270740

### CHASSIS AND ENCLOSURES

| KEY NO. | PART NO.   | DESCRIPTION                     |
|---------|------------|---------------------------------|
| 1       | 169830     | Chassis Stamping                |
| 2       | 169061     | Drawbar                         |
| 3       | 17060612   | Screw 3/8-16 x 3/4              |
| 5       | 155272     | Bumper Hood/Dash                |
| 9       | 168337X013 | Dash                            |
| 10      | STD533710  | Bolt, Carriage 3/8-16 x 1       |
| 11      | 155927     | Panel, Dash, L.H.               |
| 12      | 145660     | Clip Tinnerman Grille P/L       |
| 13      | 172107X010 | Panel, Dash, R.H.               |
| 17      | 144983X558 | Hood Assembly                   |
| 18      | 126938X    | BumperHood                      |
| 25      | 19131312   | Washer 13/32 x 13/16 x 12 Gauge |
| 26      | STD541437  | Nut                             |
| 28      | 166217X558 | Grille w/Clips                  |
| 29      | 155217X599 | Lens, Grille                    |
| 30      | 164918X558 | Fend/Frest Pnt STL T W/CPH 558  |
| 31      | 139976     | Bracket, Fender Support         |
| 37      | 17490508   | Screw Thdrol 5/16-18 x 1/2 Tyt  |
| 38      | 169834     | Bracket Asm. Pivot Mower Rear   |
| 51      | 73800400   | Nut Lock w/Insert 1/4-20 UNC    |
| 52      | 19091416   | Washer 9/32 x 7/8 x 16 Ga.      |
| 53      | 145201     | Bracket Grille Pickoff LH       |
| 54      | 161464     | Screw Hex Wshd 8-18 x 7/8       |
| 55      | 145202     | Bracket Grille Pickoff RH       |
| 57      | STD522507  | Bolt, Fin Hex 1/4-20 UNC x .75  |
| 58      | 150127     | Duct Air Engine P/L LT          |
| 60      | 72140606   | Bolt Rdhd Sqnk 3/8-16 UNC x 3/4 |
| 64      | 154798     | Dash Lower STL T                |
| 74      | 73680600   | Nut Crownlock 3/8-16 UNC        |
| 142     | 165867     | Plate Reinforcement STL T       |
| 143     | 154966     | Bracket Swaybar Chassis         |
| 144     | 154207     | Bracket Pnt Footrest STL T      |
| 145     | 156524     | RJod Pivot Chassis/Hood         |
| 206     | 170165     | Bolt Shoulder 5/16 -18 TT       |
| 207     | 17670508   | Screw Thdrol 5/16-18 x 1/2 TYTT |
| 208     | 17670608   | Screw Thdrol 3/8-16 x 1/2       |
| --      | 5479J      | Plug, Button                    |

**NOTE:** All component dimensions given in U.S. inches  
1 inch = 25.4 mm

# TRACTOR -- MODEL NUMBER 917.270740

## GROUND DRIVE

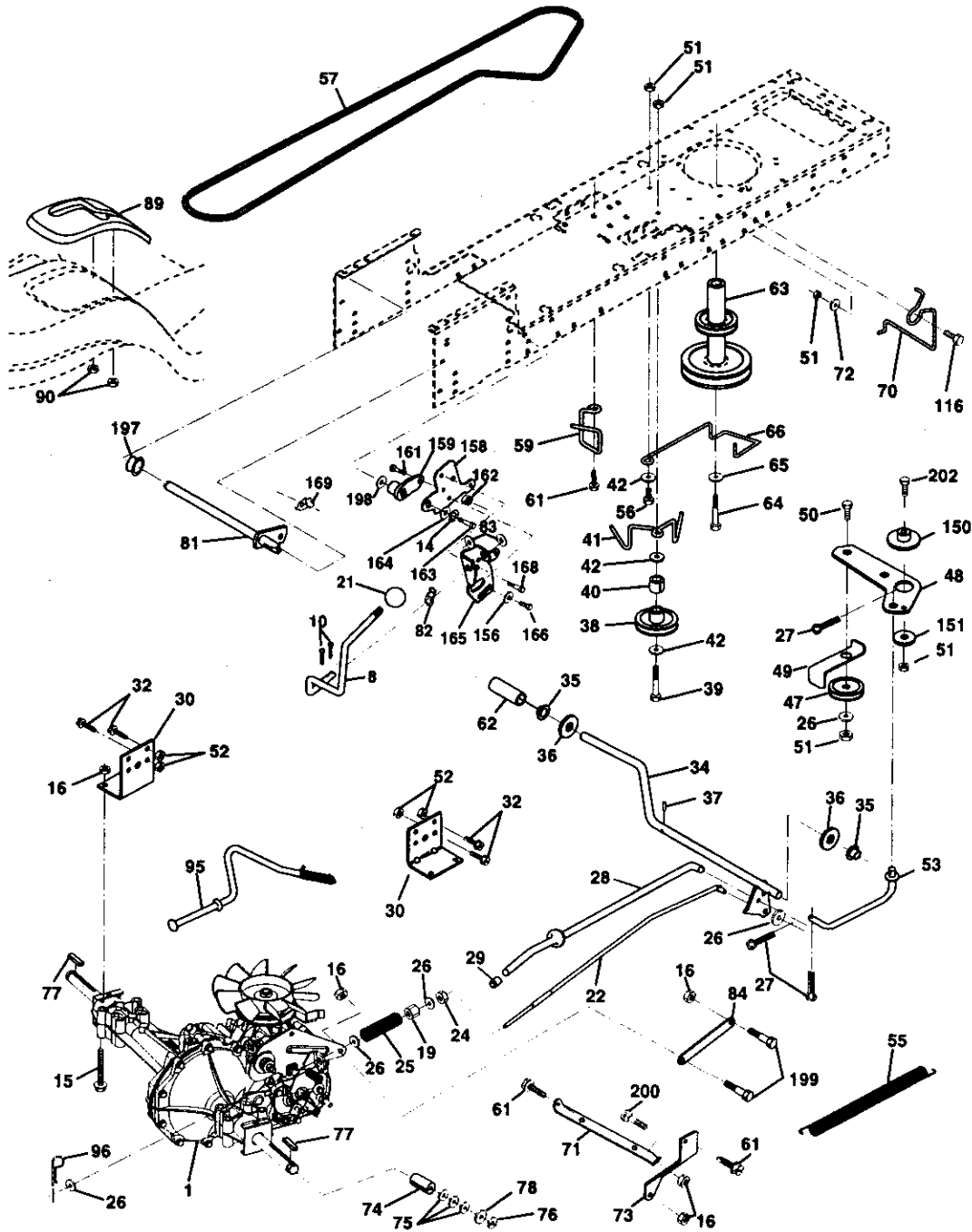

## TRACTOR -- MODEL NUMBER 917.270740

### GROUND DRIVE

| KEY NO. | PART NO.  | DESCRIPTION                    | KEY NO. | PART NO.   | DESCRIPTION                      |
|---------|-----------|--------------------------------|---------|------------|----------------------------------|
| 1       | -----     | Transaxle (See Breakdown)      | 65      | STD551143  | Washer                           |
| 8       | 165866    | Hydro Gr 314-0510              | 66      | 154778     | Keeper Belt Engine Hydro         |
| 10      | STD561210 | Rod Shift Fender Adjust        | 70      | 134683     | Keeper Belt Engine               |
| 14      | 10040400  | Pin Cotter 1/8 x 1 CAD         | 71      | 169183     | Strap Torque Lh Hydro            |
| 15      | 74490544  | Washer Lock Hvy Helical        | 72      | 19132012   | Washer 13/32 x 1-1/4 x 12 Ga.    |
| 16      | STD541431 | Bolt Hex FlgHd 5/16-18 x Gr. 5 | 73      | 169182     | Strap Torque Rh Hydro            |
| 19      | STD541437 | Nut Lock Hex W/Ins. 5/16-18    | 74      | 169496     | Spacer, Split                    |
| 21      | 130564    | Unc                            | 75      | 121749X    | Washer 25/32 x 1-1/4 x 16 Ga.    |
| 22      | 169498    | Nut Lock Hex W/Wsh 3/8-16      | 76      | STD581075  | E-Ring                           |
| 24      | 73350600  | Unc                            | 77      | 123583X    | Key, Square                      |
| 25      | 106888X   | Knob, Deluxe 1/2-13            | 78      | 121748X    | Washer 25/32 x 1-5/8 x 16 Ga.    |
| 26      | STD551037 | Rod, Brake Hydro               | 81      | 165596     | Shaft Asm Cross Tapered          |
| 27      | STD561210 | Nut, Hex Jam 3/8-16 Unc        | 82      | 165711     | Spring Torsion                   |
| 28      | 145204    | Spring, Brake Rod              | 83      | 19171216   | Washer 17/32 x 3/4 x 16 Ga.      |
| 29      | 71673     | Washer                         | 84      | 169594     | Link Transaxle                   |
| 30      | 169592    | Pin Cotter 1/8 x 3/4 CAD.      | 89      | 164890X428 | Console, Shift                   |
| 32      | 74760512  | Rod, Parking Brake             | 90      | 124346X    | Nut Self-Thd Wsh-hd 1/4 Zinc     |
| 34      | 155071    | Cap, Parking Brake             | 95      | 170201     | Control Bypass Hydro 20" Tires   |
| 35      | 120183X   | Bracket, Transaxle             | 96      | 4497H      | Retainer Spring 1" Zinc/Cad      |
| 36      | 19211616  | Bolt Hex Hd 5/16-18 Unc x 3/4  | 116     | 72110610   | Bolt Rdhd Sqneck 3/8-16 x 1.25   |
| 37      | 1572H     | Shaft, Foot Pedal              | 150     | 165850     | Bushing Bellcrank Grd Drive      |
| 38      | 131494    | Bearing, Nylon                 | 151     | 19133210   | Washer 13/32 x 2 x 10 Ga.        |
| 39      | 72110622  | Washer                         | 156     | 166002     | Washer Srrted 5/16ID x 1.125     |
| 40      | 4470J     | Pin, Roll                      | 158     | 165589     | Bracket Shift Mount              |
| 41      | 165838    | Pulley, Idler, Flat            | 159     | 165494     | Hub Tapered Flange Shift Lt      |
| 42      | 19131312  | Bolt                           | 161     | 72140406   | Bolt Rdhd Sqnk 1/4-20 x 3/4      |
| 47      | 127783    | Spacer, Split                  | 162     | 73680400   | Gr. 5                            |
| 48      | 154407    | Keeper, Belt Idler             | 163     | 74780416   | Nut Crownlock 1/4-20 Unc         |
| 49      | 123205X   | Washer 13/32 x 13/16 x 12 Ga.  | 164     | 19091010   | Bolt Hex Fin 1/4-20 Unc x 1      |
| 50      | STD523715 | Pulley, Idler, V-Groove        | 165     | 165623     | Gr. 5                            |
| 51      | STD541437 | Bellcrank, Clutch              | 166     | 166880     | Washer 5/8 x .281 x 10 Ga        |
| 52      | STD541431 | Retainer, Belt                 | 168     | 165492     | Bracket Pivot Lever              |
| 53      | 105710X   | Bolt                           | 169     | 165580     | Screw 5/16-18 x 5/8              |
| 55      | 105709X   | Nut Crownlock 3/8-16 UNC       | 197     | 169613     | Bolt Shoulder 5/16-18 x .561     |
| 56      | STD523712 | Nut, Crownlock 5/16-18 Unc     | 198     | 169593     | Plate Fastening                  |
| 57      | 140294    | Link, Clutch                   | 199     | 169612     | Nyliner Snap-In 5/8"ID           |
| 59      | 169691    | Spring, Return, Clutch         | 200     | 72140508   | Washer Nyl 7/8 ID x .105" Hyd    |
| 61      | 17060612  | Bolt Hex 3/8-16 x 1-1/4        | 202     | 72110612   | Bolt Shoulder 5/16-18UNC         |
| 62      | 8883R     | V-Belt                         |         |            | Bolt Rdhd Sgnk 5/16-18UNC x 1    |
| 63      | 140186    | Keeper, Center Span            |         |            | Bolt Carr Sh 3/8-16 x 1-1/2 Gr.5 |
| 64      | 71170764  | Screw . 3/8-16 x 3/4           |         |            |                                  |
|         |           | Cover, Pedal                   |         |            |                                  |
|         |           | Pulley, Engine                 |         |            |                                  |
|         |           | Bolt Hex 7/16-20 x 4 Gr. 5     |         |            |                                  |

NOTE: All component dimensions given in U.S. inches  
1 inch = 25.4 mm

# TRACTOR -- MODEL NUMBER 917.270740

## STEERING ASSEMBLY

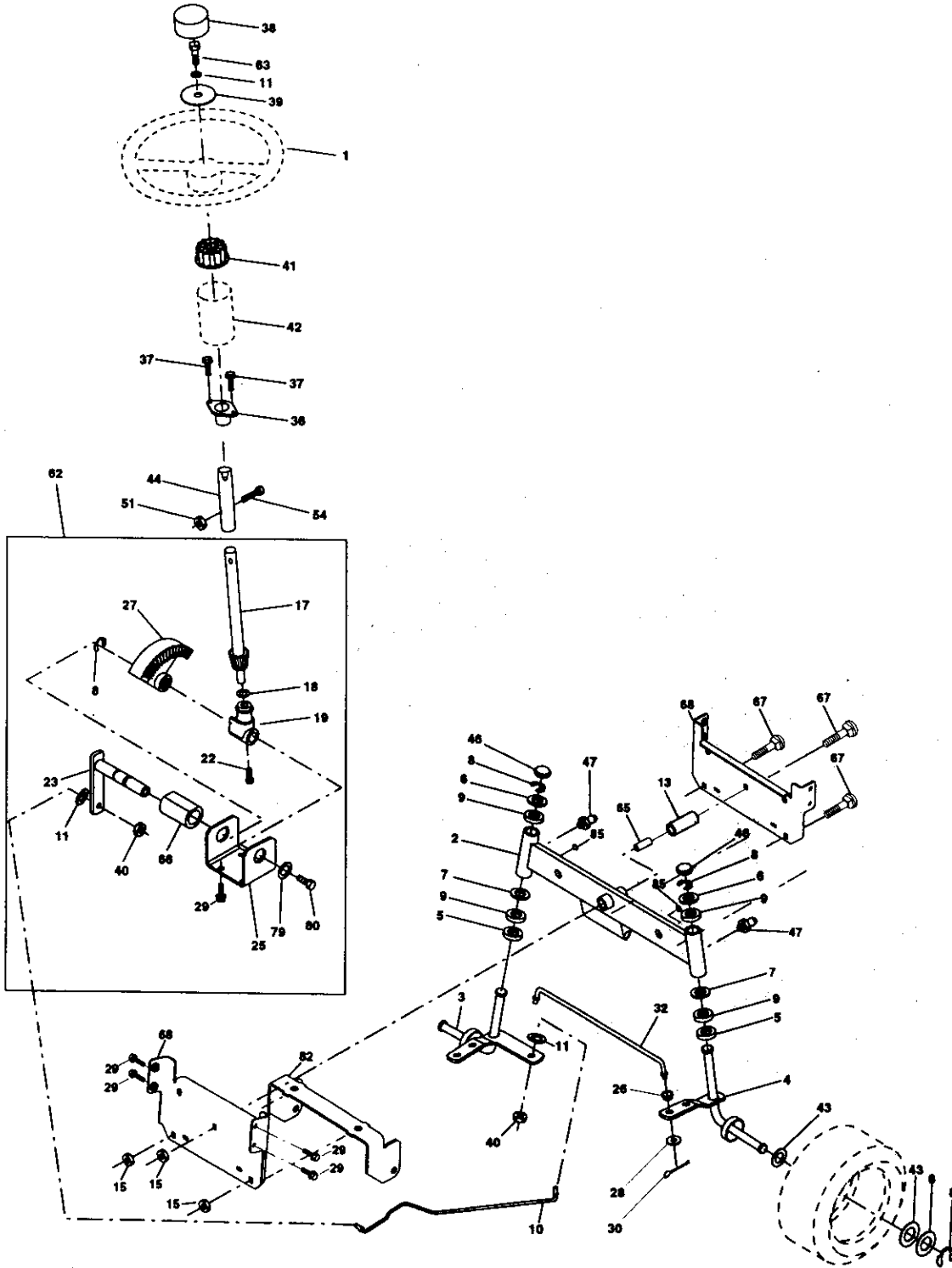



# TRACTOR-- MODEL NUMBER 917.270740

## STEERING ASSEMBLY

| KEY NO. | PART NO.   | DESCRIPTION                       |
|---------|------------|-----------------------------------|
| 1       | 139768     | Steering Wheel                    |
| 2       | 154427     | Axle Assembly STMP Dropped STL    |
| 3       | 169840     | Spindle Assembly, L.H.            |
| 4       | 169839     | Spindle Assembly, R.H.            |
| 5       | 6266H      | Bearing, Race, Thrust, Hardened   |
| 6       | 121748X    | Washer 25/32 x 1-5/8 x 16 Gauge   |
| 7       | 19272016   | Washer 27/32 x 1-1/4 x 16 Gauge   |
| 8       | 12000029   | Ring, Klip                        |
| 9       | 3366R      | Bearing, Steering Column          |
| 10      | 169832     | Draglink                          |
| 11      | STD551137  | Washer, Lock                      |
| 13      | 136518     | Spacer Brg Axle Front             |
| 15      | 145212     | Nut, Hexflange Lock               |
| 17      | 156546     | Shaft Assembly, Steering          |
| 18      | 57079      | Washer, Thrust .515 x .750 x .033 |
| 19      | 160395     | Support, Shaft                    |
| 22      | 165857     | Screw Hex Wshhd Torx              |
| 23      | 165851     | Pittman Shaft Assembly            |
| 25      | 154406     | Bracket, Steering                 |
| 26      | 126847X    | Bushing, Link, Drag               |
| 27      | 136874     | Gear, Sector                      |
| 28      | 19131416   | Washer 13/32 x 7/8 x 16 Gauge     |
| 29      | 17060612   | Screw 3/8-16 x 3/4                |
| 30      | STD561210  | Pin                               |
| 32      | 130465     | Rod, Tie                          |
| 36      | 155099     | Bushing, Steering                 |
| 37      | 152927     | Screw                             |
| 38      | 139769     | Insert, Steering Wheel            |
| 39      | 19133812   | Washer 13/32 x 2-3/8 x 12 Gauge   |
| 40      | STD541537  | Nut Lock Center 3/8-24 UNF        |
| 41      | 100711L    | Adaptor, Steering Wheel           |
| 42      | 145054x428 | Boot, Steering Shaft              |
| 43      | 121749X    | Washer 25/32 x 1-1/4 x 16 Gauge   |
| 44      | 153720     | Extension Shaft Steering LR.LT    |
| 46      | 121232X    | Cap, Spindle                      |
| 47      | 6855M      | Fitting, Grease                   |
| 51      | STD541431  | Nut Lock Hex w/Ins. 5/16-18 UNC   |
| 54      | 74780520   | Bolt Fin Hex 5/16-18 UNC x 1-1/4  |
| 62      | 167902     | Kit Steering Asm Service          |
| 63      | STD523710  | Bolt, Fin Hex 3/8-16 UNC x 1 Gr 5 |
| 65      | 160367     | Spacer Brace Axle                 |
| 66      | 154404     | Bearing Arm Pittman               |
| 67      | 72140618   | Bolt Rdhd Sqnk 3/8-16 Unc x 2-1/4 |
| 68      | 169827     | Axle, Brace                       |
| 79      | 19132012   | Washer 13/32 x 1-1/4 x 12 Ga      |
| 80      | 74950612   | Bolt Hex Nylon 3/8-16 x 3/4       |
| 82      | 169835     | Bracket Susp Chassis Front        |
| 85      | 133835     | Fastner Christmas Tree            |

NOTE: All component dimensions given in U.S. inches  
1 inch = 25.4 mm

# TRACTOR -- MODEL NUMBER 917.270740

## ENGINE

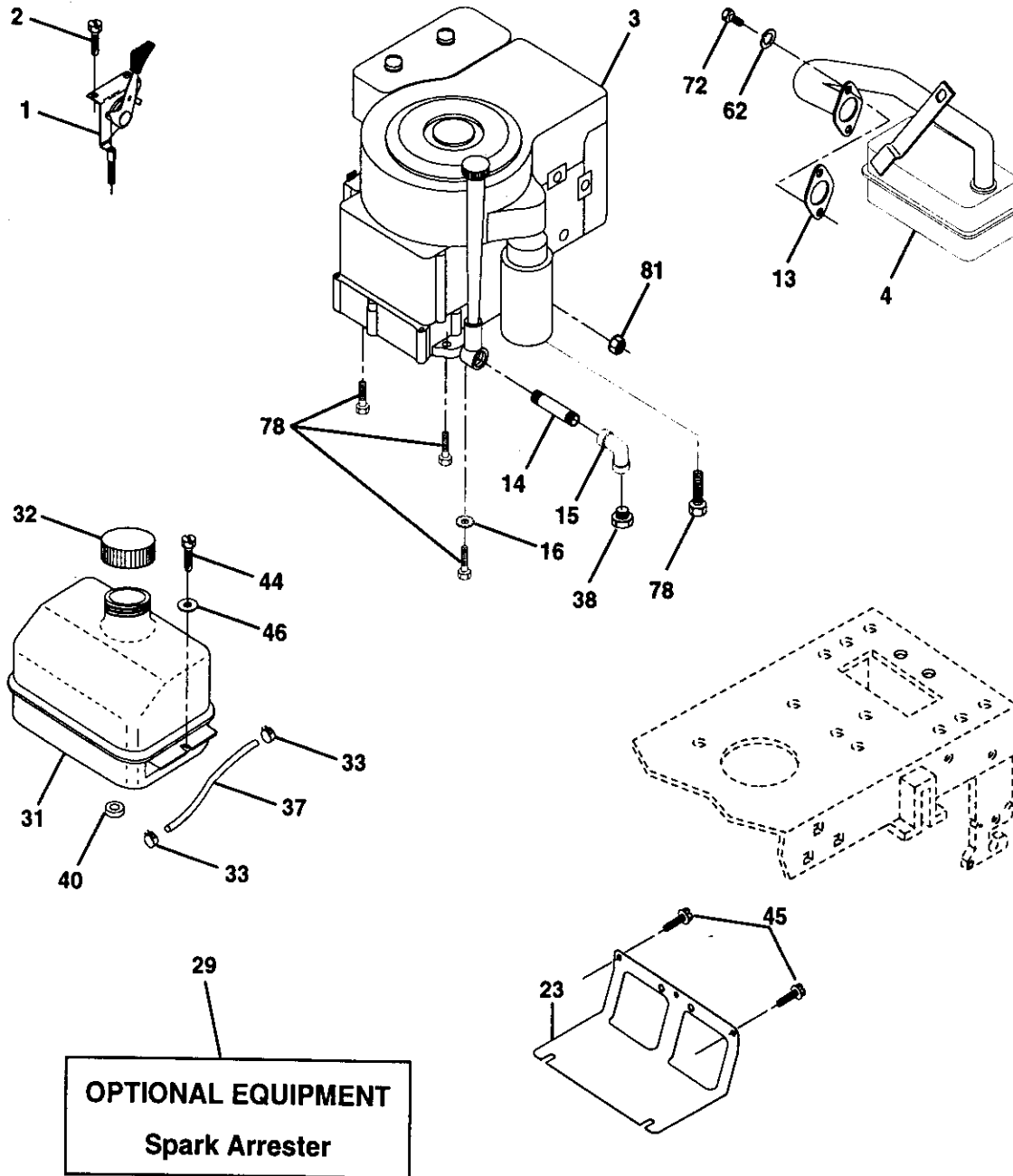

# TRACTOR -- MODEL NUMBER 917.270740

## ENGINE

| KEY NO. | PART NO.  | DESCRIPTION                                             |
|---------|-----------|---------------------------------------------------------|
| 1       | 162157    | Control, Throttle                                       |
| 2       | 17720410  | Screw, Hex Head, Thread Cutting 1/4-20 x 5/8            |
| 3       | -----     | Engine, (See Breakdown) Briggs Model No. 311707-0132-E1 |
| 4       | 137352    | Muffler                                                 |
| 13      | 165291    | Gasket Kohler                                           |
| 14      | 13280324  | Nipple, Pipe 3/8 NPT x 3                                |
| 15      | 13200300  | Elbow, Standard 90°, 3/8-18 NPT                         |
| 16      | STD551237 | Washer                                                  |
| 23      | 169837    | Shield Brn/Dbr Guard                                    |
| 29      | 137180    | Arrestor, Spark                                         |
| 31      | 109202X   | Tank, Fuel                                              |
| 32      | 158990    | Cap Assembly, Fuel Sears, Vented                        |
| 33      | 123487X   | Clamp, Hose                                             |
| 37      | 137040    | Line, Fuel                                              |
| 38      | -----     | Plug, Oil Drain (See Engine Breakdown)                  |
| 40      | 124028X   | Bushing, Snap, Fuel Line                                |
| 44      | 17490412  | Screw, Hex Washer Head, Thd., Roll. 1/4-20 x 3/4        |
| 45      | 17060612  | Screw 3/8-16 x .75                                      |
| 46      | 19091416  | Washer 9/32 x 7/8 x 16 Gauge                            |
| 62      | 10040500  | Washer Lock Hvy. Hlcl Spr. 5/16                         |
| 72      | 71070512  | Screw Hex Hd Cap 5/16-18 x 3/4                          |
| 78      | 17060620  | Screw 3/8-16 x 1-1/4                                    |
| 81      | 73510400  | Nut Keps Hex 1/4-20 Unc                                 |

**NOTE:** All component dimensions given in U.S. inches  
1 inch = 25.4 mm

# TRACTOR -- MODEL NUMBER 917.270740

## SEAT ASSEMBLY

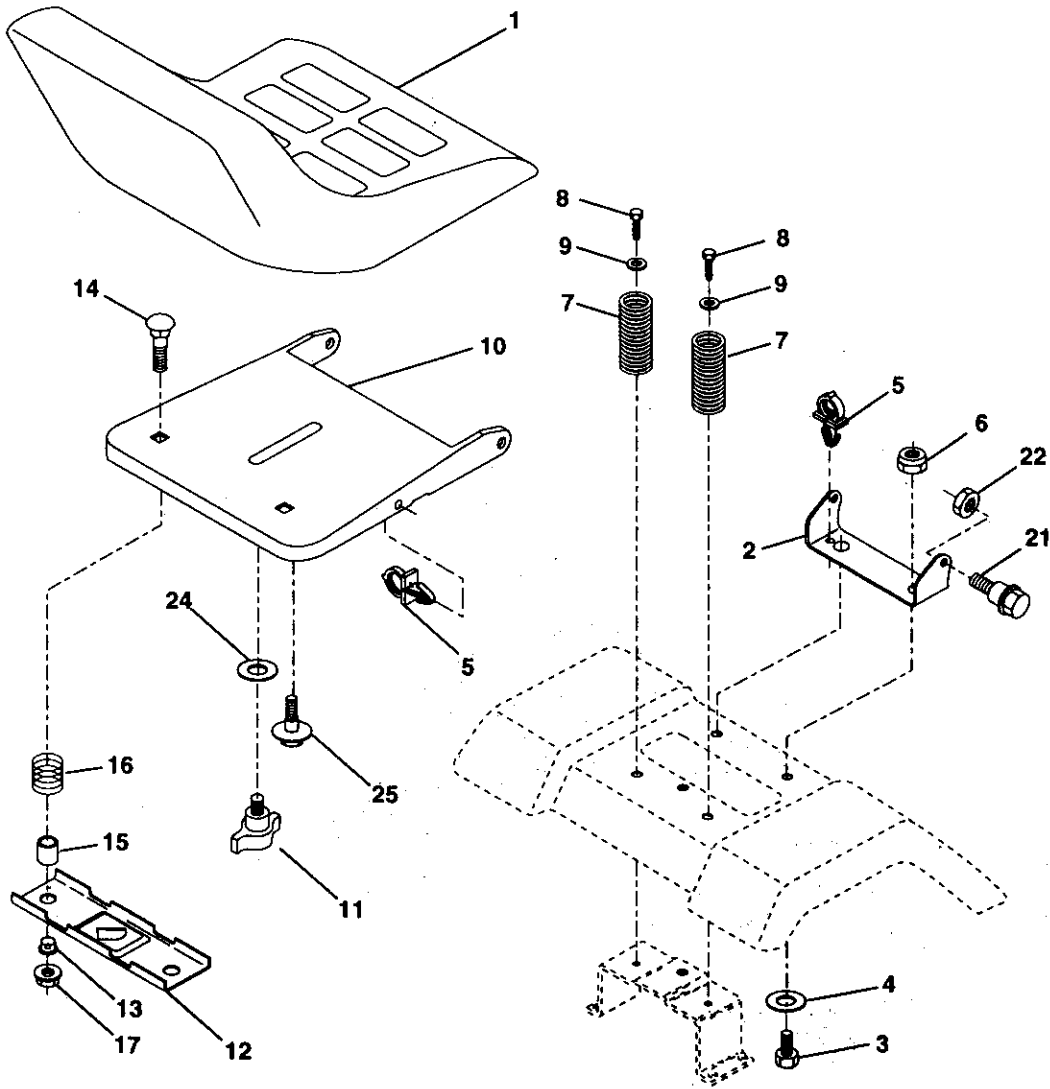

| KEY NO. | PART NO.  | DESCRIPTION                 |
|---------|-----------|-----------------------------|
| 1       | 140123    | Seat                        |
| 2       | 140551    | Bracket, Pivot, Seat        |
| 3       | 71110616  | Bolt                        |
| 4       | 19131610  | Washer 13/32 x 1 x 10 Gauge |
| 5       | 145006    | Clip, Push-In Hinged        |
| 6       | STD541437 | Nut                         |
| 7       | 124181X   | Spring, Seat                |
| 8       | 17000616  | Screw 3/8-16 x 1-1/2        |
| 9       | 19131614  | Washer 13/32 x 1 x 14 Gauge |
| 10      | 155925    | Pan, Seat Emboss QCK Conn.  |
| 11      | 166369    | Knob Seat                   |
| 12      | 121246X   | Bracket, Switch Mounting    |

| KEY NO. | PART NO.  | DESCRIPTION                    |
|---------|-----------|--------------------------------|
| 13      | 121248X   | Bushing, Snap                  |
| 14      | 72050412  | Bolt, Carriage 1/4-20 x 1-1/2  |
| 15      | 134300    | Spacer, Split .28 x .88        |
| 16      | 121250X   | Spring                         |
| 17      | 123976X   | Locknut, Flange 1/4 Grade 5    |
| 21      | 171852    | Bolt, Shoulder 5/16-18 UNC     |
| 22      | STD541431 | Nut                            |
| 24      | 19171912  | Washer 17/32 x 1-3/16 x 12 Ga. |
| 25      | 127018X   | Bolt, Shoulder 5/16-18 x .62   |

**NOTE:** All component dimensions given in U.S. inches  
1 inch = 25.4 mm

# TRACTOR -- MODEL NUMBER 917.270740

## DECALS

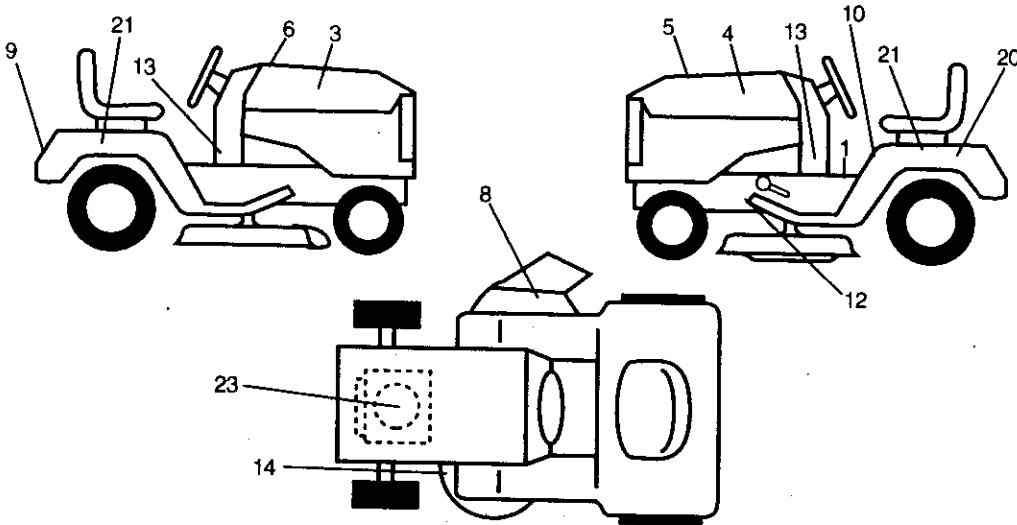

| KEY NO. | PART NO. | DESCRIPTION                   | KEY NO. | PART NO.   | DESCRIPTION                 |
|---------|----------|-------------------------------|---------|------------|-----------------------------|
| 1       | 156811   | Decal, Oper. Instr.           | 20      | 149516     | Decal, Battery Dngr/Psn Eng |
| 3       | 171696   | Decal, Hood, R.H.             | 21      | 163205     | Decal, Fender Auto Sears    |
| 4       | 171697   | Decal, Hood, L.H.             | 23      | 165406     | Decal, Engine               |
| 5       | 171761   | Decal Hood Replacement        | --      | 138311     | Decal, Lift Handle          |
| 6       | 133644   | Decal, Customer Maintenance   | --      | 165800X428 | Pad Footrest LH STL         |
| 8       | 166887   | Decal, Deck EZ3               | --      | 165799X428 | Pad Footrest RH STL         |
| 9       | 163204   | Decal, Fender, Craftsman      | --      | 169210     | Decal By Pass LT Hydro      |
| 10      | 156439   | Decal, Fender Danger          | --      | 172173     | Owner's Manual, English     |
| 12      | 146046   | Decal, V-Belt Drive Schematic | --      | 172174     | Owner's Manual, Spanish     |
| 13      | 163254   | Decal, Dash Pnl               |         |            |                             |
| 14      | 160396   | Decal, V-Belt Schematic       |         |            |                             |

## WHEELS & TIRES

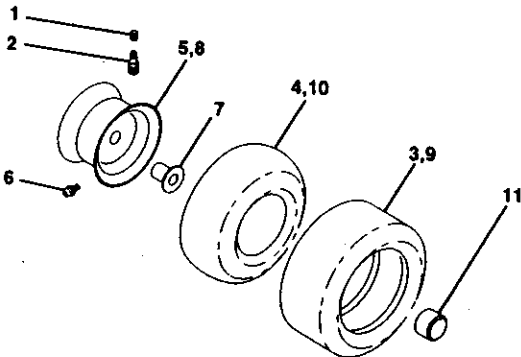

| KEY NO. | PART NO.   | DESCRIPTION                                           |
|---------|------------|-------------------------------------------------------|
| 1       | 59192      | Valve Cap, Tire                                       |
| 2       | 65139      | Stem, Valve                                           |
| 3       | 106222X    | Tire, Front                                           |
| 4       | 59904      | Tube, Front Tire<br>(Not Provided, Service Item Only) |
| 5       | 106732X427 | Rim, Front                                            |
| 6       | 278H       | Fitting, Grease (Front Wheel Only)                    |
| 7       | 9040H      | Bearing, Flange (Front Wheel Only)                    |
| 8       | 106108X427 | Rim, Rear                                             |
| 9       | 122082X    | Tire, Rear                                            |
| 10      | 7152J      | Tube, Rear Tire<br>(Not Provided, Service Item Only)  |
| 11      | 104757X    | Cap, Axle                                             |
| --      | 144334     | Sealant, Tire 10 oz.                                  |

NOTE: All component dimensions given in U.S. inches  
1 inch = 25.4 mm

TRACTOR-- MODEL NUMBER 917.270740

LIFT ASSEMBLY

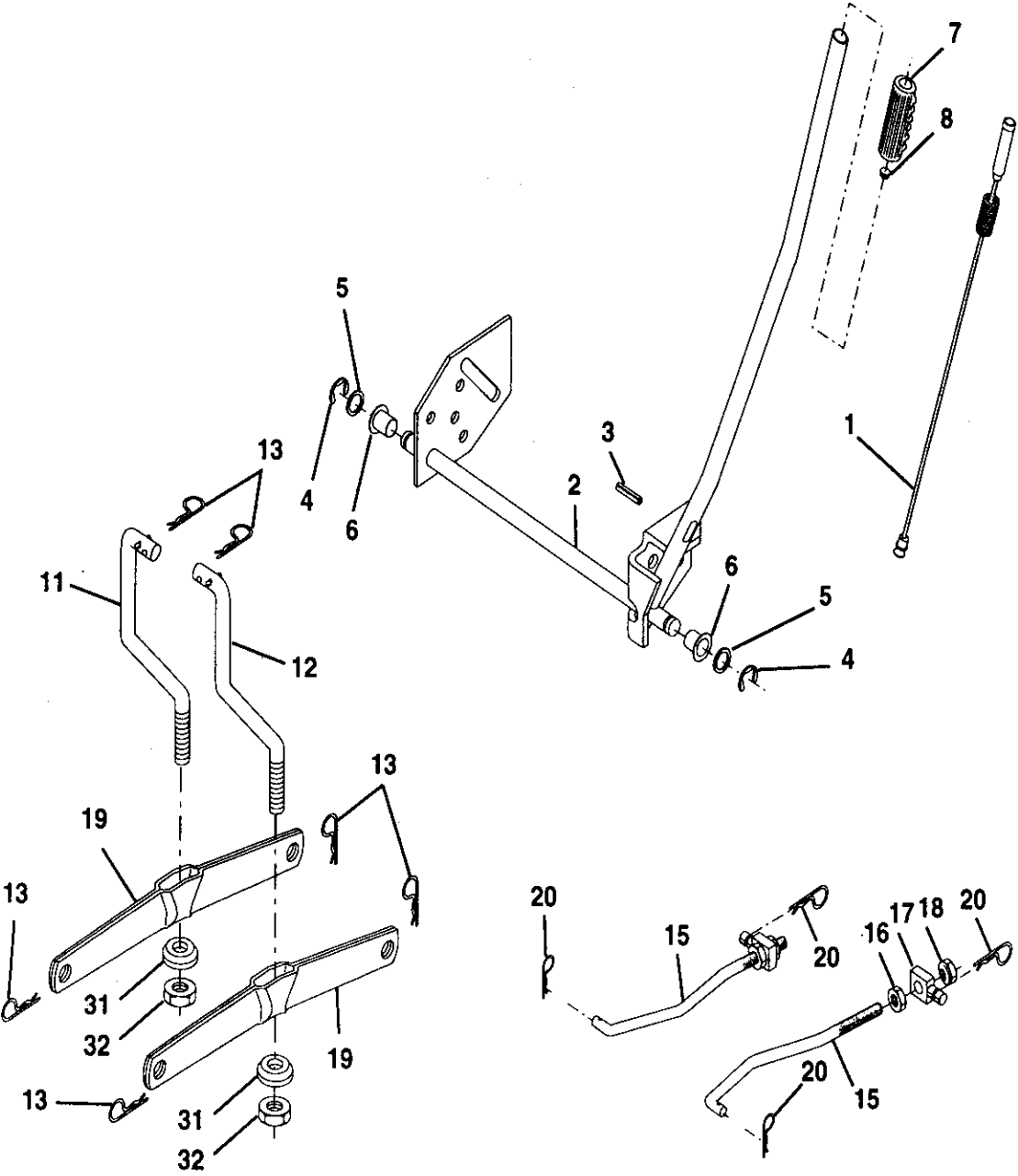

# TRACTOR -- MODEL NUMBER 917.270740

## LIFT ASSEMBLY

| KEY NO. | PART NO.  | DESCRIPTION                                 |
|---------|-----------|---------------------------------------------|
| 1       | 159460    | Lift Lever Inner Wire Assembly              |
| 2       | 159471    | Shaft Assembly, Lift                        |
| 3       | 105767X   | Pin, Groove                                 |
| 4       | 12000002  | E-Ring                                      |
| 5       | 19211621  | Washer 21/32 x 1 x 21 Gauge                 |
| 6       | 120183X   | Bearing, Nylon                              |
| 7       | 125631X   | Grip, Handle, Fluted                        |
| 8       | 122365X   | Button, Plunger, Red                        |
| 11      | 139865    | Link, Lift, L.H.                            |
| 12      | 139866    | Link, Lift, R.H.                            |
| 13      | STD624008 | Retainer Spring                             |
| 15      | 167253    | Link, Front                                 |
| 16      | 73350800  | Nut, Hex, Jam 1/2-13 UNC                    |
| 17      | 130171    | Trunnion                                    |
| 18      | 73800800  | Locknut, Hex, with Washer Insert 1/2-13 UNC |
| 19      | 139868    | Arm, Suspension, Rear                       |
| 20      | 163552    | Retainer Spring                             |
| 31      | 140302    | Bearing, Pvt, Lift Spherical                |
| 32      | 73540600  | Nut, Crownlock 3/8-24                       |

**NOTE:** All component dimensions given in U.S. inches  
1 inch = 25.4 mm

# TRACTOR -- MODEL NUMBER 917.270740

## MOWER DECK

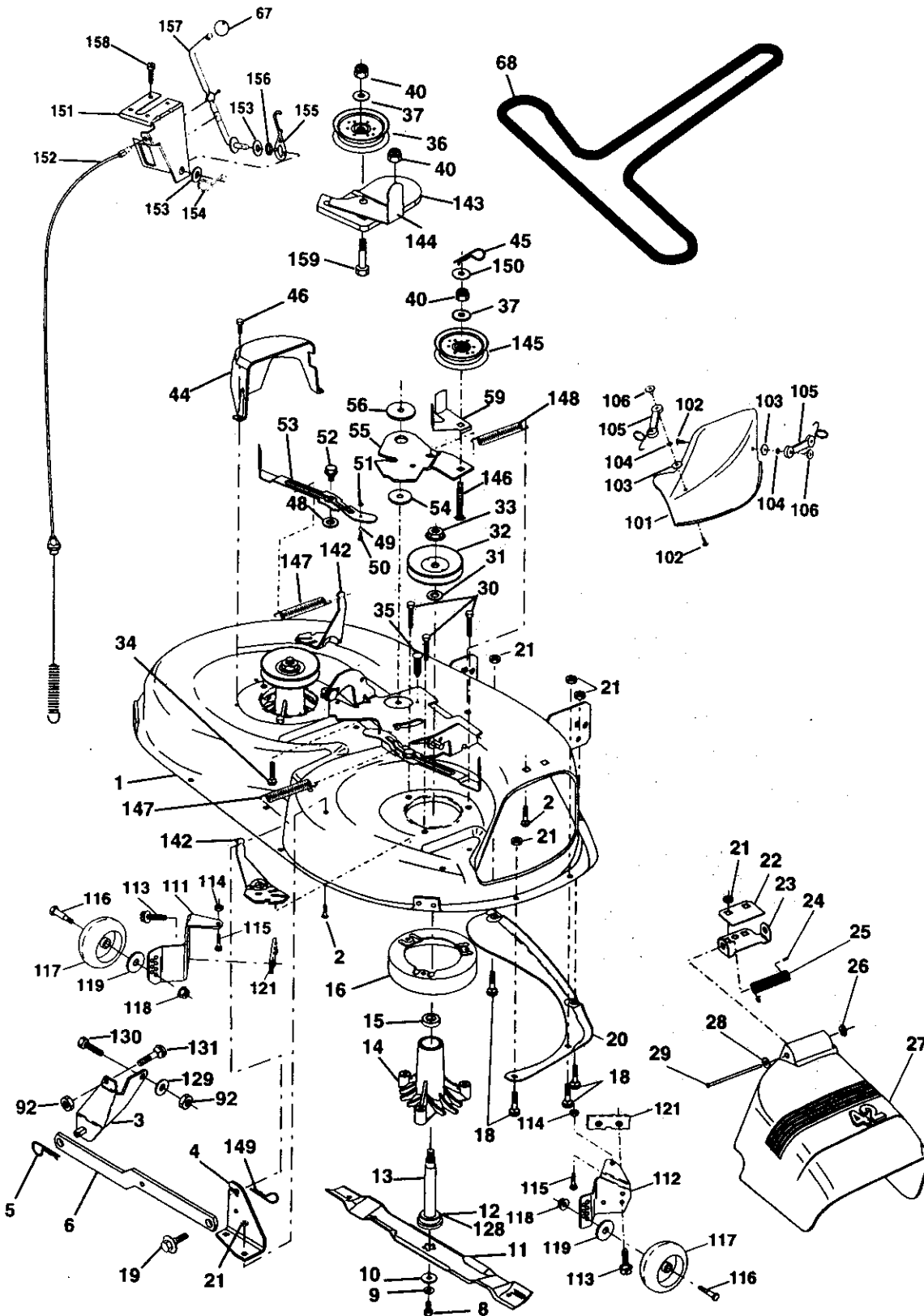



## TRACTOR -- MODEL NUMBER 917.270740

### MOWER DECK

| KEY NO. | PART NO.   | DESCRIPTION                                              | KEY NO. | PART NO.  | DESCRIPTION                                                                                                                   |
|---------|------------|----------------------------------------------------------|---------|-----------|-------------------------------------------------------------------------------------------------------------------------------|
| 1       | 165892     | Mower Deck Assembly, 42"                                 | 68      | 144959    | V-Belt                                                                                                                        |
| 2       | STD533107  | Bolt                                                     | 92      | STD541437 | Nut                                                                                                                           |
| 3       | 138017     | Bracket Assembly, Sway Bar, Front                        | 101     | 136420    | Mulcher Cover                                                                                                                 |
| 4       | 165460     | Bracket Sway Bar 38/42" Deck                             | 102     | 71161010  | Screw                                                                                                                         |
| 5       | STD624008  | Retainer Spring                                          | 103     | 19061216  | Washer #10                                                                                                                    |
| 6       | 130832     | Arm, Suspension, Rear                                    | 104     | STD551110 | Washer, Lock                                                                                                                  |
| 8       | 850857     | Bolt, Hex 3/8-24 x 1.25 Gr. 8                            | 105     | 160793    | Latch Assembly, Bagger                                                                                                        |
| 9       | STD551137  | Washer, Lock                                             | 106     | 2029J     | Nut, Weld                                                                                                                     |
| 10      | 140296     | Washer, Hardened                                         | 111     | 155197    | Bracket, Gauge, Wheel L.H.                                                                                                    |
| 11      | 134149     | Blade, Mulching                                          | 112     | 155198    | Bracket, Gauge, Wheel R.H.                                                                                                    |
| 12      | 129895     | Bearing, Ball                                            | 113     | 17060512  | Screw 5/16-18 x 3/4                                                                                                           |
| 13      | 137645     | Shaft Assembly, Mandrel, Vented (Includes Key Number 12) | 114     | STD541431 | Nut, Hex, Keps 5/16-18 UNC                                                                                                    |
| 14      | 128774     | Housing, Mandrel, Vented                                 | 115     | 72110504  | Bolt, Carriage 5/16 UNC x 1/2                                                                                                 |
| 15      | 110485X    | Bearing, Ball, Mandrel                                   | 116     | 4898H     | Bolt, Shoulder                                                                                                                |
| 16      | 140329     | Stripper, Vented Mower Deck                              | 117     | 165746    | Wheel, Gauge                                                                                                                  |
| 18      | 72140505   | Bolt, Carriage 5/16-18 x 5/8                             | 118     | 73930600  | Nut, Centerlock 3/8-16                                                                                                        |
| 19      | 132827     | Bolt, Shoulder                                           | 119     | STD551037 | Washer 3/8 x 7/8 x 14 Gauge                                                                                                   |
| 20      | 159770     | Baffle, Vortex                                           | 121     | 143723    | Bracket                                                                                                                       |
| 21      | STD541431  | Nut Crownlock 5/16-18 UNC                                | 128     | 153390    | Washer Felt                                                                                                                   |
| 22      | 134753     | Stiffener Bracket                                        | 129     | 19131312  | Washer 13/32 x 13/16 x 12 Ga.                                                                                                 |
| 23      | 131267     | Bracket, Deflector                                       | 130     | STD523710 | Bolt, Fin Hex 3/8-16 UNC x 1 Gr. 5                                                                                            |
| 24      | 105304X    | Cap, Sleeve                                              | 131     | STD533710 | Bolt, Rdhd Sqnk 3/8-16UNC x 1                                                                                                 |
| 25      | 123713X    | Spring, Torsion, Deflector                               | 142     | 165890    | Arm Spring Brake Mower                                                                                                        |
| 26      | 110452X    | Nut, Push                                                | 143     | 157109    | Bracket Arm Idler 42"                                                                                                         |
| 27      | 130968X428 | Shield, Deflector                                        | 144     | 158634    | Keeper Belt 42" Clutch Cable                                                                                                  |
| 28      | 19111016   | Washer 11/32 x 5/8 x 16 Ga.                              | 145     | 165888    | Pulley Idler Flat                                                                                                             |
| 29      | 131491     | Rod, Hinge                                               | 146     | 165891    | Bolt Carriage Idler                                                                                                           |
| 30      | 157722     | Screw Thdrol Washer Head                                 | 147     | 131335    | Spring Extension                                                                                                              |
| 31      | 129963     | Washer, Spacer                                           | 148     | 169022    | Spring Return Idler                                                                                                           |
| 32      | 153535     | Pulley, Mandrel                                          | 149     | 165898    | Retainer Spring Yellow Zinc                                                                                                   |
| 33      | 137266     | Nut, Toplock, Flanged                                    | 150     | 19091216  | Washer 9/32 x 3/4 x 16 Ga.                                                                                                    |
| 34      | STD533717  | Bolt                                                     | 151     | 169670    | Bracket Clutch                                                                                                                |
| 35      | 133835     | Fastner, Christmas Tree                                  | 152     | 169676    | Cable Clutch 42 In                                                                                                            |
| 36      | 131494     | Pulley, Idler, Flat                                      | 153     | 169674    | Washer Flat 3/8" Type B                                                                                                       |
| 37      | STD551037  | Washer 13/32 x 13/16 x 16 Gauge                          | 154     | 169675    | Spring Retainer                                                                                                               |
| 40      | STD541437  | Nut Crownlock 3/8-16 UNC                                 | 155     | 169671    | Spring Retention Lever                                                                                                        |
| 44      | 140088     | Guard, Mandrel, L.H.                                     | 156     | 169672    | Spacer                                                                                                                        |
| 45      | STD624003  | Retainer                                                 | 157     | 169669    | Rod Clutch                                                                                                                    |
| 46      | 137729     | Screw, Thd. Roll 1/4-20 x 5/8                            | 158     | 17720410  | Screw Hex Thd Cut 1/4-20 x 5/8                                                                                                |
| 48      | 133944     | Washer, Hardened                                         | 159     | 72140614  | Bolt Rdhd Sqn 3/8-16 UNC x 1-3/4                                                                                              |
| 49      | 155066     | Roller Assembly, Cam Follower                            | --      | 130794    | Mandrel Assembly (Includes Key Numbers 8-10, 12-15, 31 and 32)                                                                |
| 50      | 131340     | Bolt, Shoulder #10-24 Grade 5                            | --      | 169583    | Mower Deck, Complete (Standard Deck, Order Separately Mulcher Plate and Gauge Wheel Components, Key Nos. 101-106 and 111-121) |
| 51      | STD541410  | Locknut                                                  |         |           |                                                                                                                               |
| 52      | 139888     | Bolt, Shoulder 5/16-18 UNC                               |         |           |                                                                                                                               |
| 53      | 131845     | Arm Assembly, Pad, Brake                                 |         |           |                                                                                                                               |
| 54      | 133943     | Washer, Hardened                                         |         |           |                                                                                                                               |
| 55      | 155046     | Arm, Idler                                               |         |           |                                                                                                                               |
| 56      | 165723     | Spacer, Retainer                                         |         |           |                                                                                                                               |
| 59      | 141043     | Guard, TUV Idler                                         |         |           |                                                                                                                               |
| 67      | 149846     | Knob Custom Oval                                         |         |           |                                                                                                                               |

**NOTE:** All component dimensions given in U.S. inches  
1 inch = 25.4 mm

**TRACTOR -- MODEL NUMBER 917.270740**  
**HYDRO GEAR TRANSAXLE -- MODEL NUMBER 314-0510**

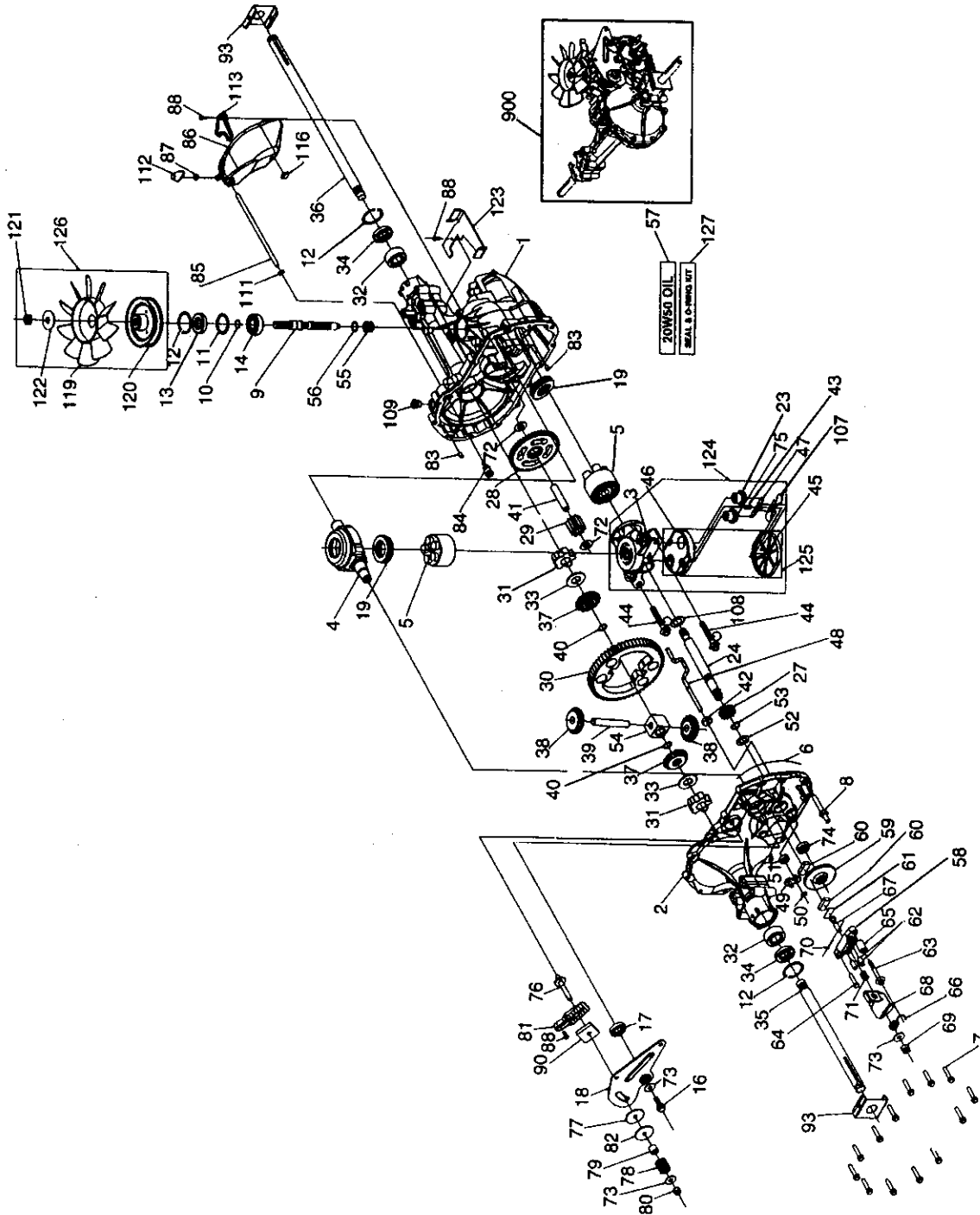

## TRACTOR -- MODEL NUMBER 917.270740

### HYDRO GEAR TRANSAXLE - - MODEL NUMBER 314-0510

| KEY NO. | PART NO. | DESCRIPTION                                | KEY NO. | PART NO. | DESCRIPTION                                 |
|---------|----------|--------------------------------------------|---------|----------|---------------------------------------------|
| 1       | 170351   | Main Housing, Assembly                     | 59      | 170408   | Rotor, Brake                                |
| 2       | 170352   | Side Housing, Assembly                     | 60      | 142883   | Brake Puck                                  |
| 3       | 170353   | Center Section, Assembly                   | 61      | 142881   | Puck Plate                                  |
| 4       | 170354   | Swashplate, Trunion Machined               | 62      | 142887   | Brake Actuating Pin                         |
| 5       | 169898   | Block - Assembly                           | 63      | 170410   | Hfacs 1/4-20x2 W/<br>Patch, Special Flange  |
| 6       | 170355   | Sealant 10.5 Oz                            |         |          |                                             |
| 7       | 170356   | Hex Flange Screw 1/4-20 X<br>1.25          | 64      | 142892   | Bolt, 1/4-20 X 1 W/Patch                    |
|         |          |                                            | 65      | 170411   | Spacer                                      |
| 8       | 170357   | Stud, 5/16-24 Hex Double End               | 66      | 170412   | Spring, Brake Arm Bias                      |
| 9       | 170358   | Shaft, Input                               | 67      | 170413   | Sq. Hd. Bolt 5/16-24-Ribbed                 |
| 10      | 170359   | Ring - Retaining                           | 68      | 170414   | Arm, Brake                                  |
| 11      | 170360   | Spacer                                     | 69      | 170415   | Slotted Hex Nut 5/16-24                     |
| 12      | 169870   | Ring - Retaining                           | 70      | 170416   | Cotter Pin 3/32 X 3/4                       |
| 13      | 170361   | Seal, Lip .67 X 1.58 X .276                | 71      | 170417   | Compression Spring Brake                    |
| 14      | 169869   | Ball Brg 17mm Id X 40mm Od<br>X 12mm       | 72      | 170418   | Anti-Drag                                   |
|         |          |                                            |         |          | Washer, Ht .5 I.D. X 1 O.D. X<br>.032       |
| 16      | 170362   | Hex Flange Head Screw 5/16-<br>24X0.75     | 73      | 142884   | Flat - Washer 11/32 I.D. X 7/8<br>O.D.      |
| 17      | 170363   | Lip Seal 18 X 32 X 7                       |         |          |                                             |
| 18      | 170364   | Arm, Control                               | 74      | 170419   | Oil Seal .625 X 1.0 X .25                   |
| 19      | 150771   | Bearing, 30x52x13 Thrust                   | 75      | 170420   | Check Plug Assembly, .027,<br>Washer        |
| 23      | 170365   | Check Plug Assembly, Washer                |         |          |                                             |
| 24      | 170366   | Shaft, Motor                               | 76      | 170421   | Stud, 5/16-24 Friction Pack                 |
| 27      | 170367   | Gear - Pinion, 13t                         | 77      | 170422   | Puck, .330 X 1.50 X .0975                   |
| 28      | 170368   | 10t/48t Gear                               | 78      | 142969   | Spring, Helical Comp                        |
| 29      | 170369   | Gear, 10t Jackshaft                        | 79      | 142980   | Spacer                                      |
| 30      | 170370   | 60t Bull Gear                              | 80      | 150778   | Hex Lock Nut 5/16-24                        |
| 31      | 170371   | Sleeve Bearing .75 X 1.575 X<br>.625       | 81      | 170423   | Unjif(Nylon Insert)                         |
|         |          |                                            | 82      | 170424   | Wedge, Friction Pack                        |
| 32      | 170389   | Sleeve Bearing(Outboard)<br>.75x1.750x.625 |         |          | Clip, Washer .316x1.50x.1046<br>(Plated)    |
| 33      | 142991   | Washer, 3/4 Id X 1-1/2 Od X<br>.13 Thk     | 83      | 161162   | Pin, Standard Headless                      |
|         |          |                                            | 84      | 170425   | Fitting, 5/16 Sae 5/32 Tube                 |
| 34      | 170390   | Lip Seal Axle Seal                         | 85      | 170426   | Hose, Expansion Tank                        |
| 35      | 170391   | Shaft, Axle .75 X 11.39 (Key,<br>R.H.)     | 86      | 170427   | Expansion Tank                              |
|         |          |                                            | 87      | 170424   | Cap - Poppet Valve                          |
| 36      | 170392   | Shaft, Axle .75 X 16.99 (Key,<br>L.H.)     | 88      | 170429   | Bolt, Self Tapping 10-32 X 1/2              |
|         |          |                                            | 90      | 170430   | Puck, Inner Wedge                           |
| 37      | 150792   | Miter Gear (Splined)                       | 93      | 170431   | Spring Clip - Housing Thrust                |
| 38      | 150793   | Miter Gear 15t (0.5 Id)                    | 107     | 170432   | Deflector                                   |
| 39      | 150809   | Shaft                                      | 108     | 170433   | Washer, Motor Shaft<br>.71idx1.150dx.030thk |
| 40      | 170393   | Ring, Spiral Retaining                     |         |          |                                             |
| 41      | 170394   | Pin, Jackshaft                             | 109     | 170434   | Plug, Sae #6                                |
| 42      | 170395   | Magnet, Ring                               | 111     | 170435   | O-Ring .07 X .301 I.D.                      |
| 43      | 170396   | Spring, Bypass                             | 112     | 170436   | Shield, Vent                                |
| 44      | 150797   | Hydro Mtg Screw 3/8-24 X 2.5<br>Long       | 113     | 170437   | Bracket, Support Expansion<br>Tank          |
| 45      | 170397   | Filter                                     | 116     | 170438   | Silicon Sponge                              |
| 46      | 170398   | Base, Filter                               | 119     | 170439   | Fan, 7 In.                                  |
| 47      | 170999   | Actuator, Bypass                           | 120     | 170440   | Pulley                                      |
| 48      | 170400   | Rod, Bypass Actuator                       | 121     | 170441   | Hex Lock Nut 1/2-20 (Nylon<br>Insert)       |
| 49      | 170401   | Arm, Bypass                                |         |          |                                             |
| 50      | 170202   | Retaining Ring .250 External               | 122     | 170442   | Washer, Belleville                          |
| 51      | 170403   | Seal, Lip .741 X .250 X .250<br>Tc         | 123     | 170443   | Belt Keeper                                 |
|         |          |                                            | 124     | 170444   | Center Section-Filter-Bypass<br>Assembly    |
| 52      | 170404   | Flat Washer, 5/8 Id X 1.0 Od<br>X .05 Thk  | 125     | 170445   | Filter Assembly                             |
| 53      | 170405   | Retaining Ring                             | 126     | 170446   | Fan - Pulley Service Assembly               |
| 54      | 170406   | Bearing, Center Block                      | 127     | 170447   | Seal - O-Ring Kit                           |
| 55      | 142977   | Spring - Helical Compression               | 900     | 166768   | Transaxle Complete                          |
| 56      | 142978   | Washer                                     |         |          |                                             |
| 57      | 150798   | 20w-50 Oil                                 |         |          |                                             |
| 58      | 170407   | Brake Yoke                                 |         |          |                                             |

**NOTE:** All component dimensions given in U.S. inches  
1 inch = 25.4 mm

**TRACTOR--MODEL NUMBER 917.270740**  
**BRIGGS & STRATTON ENGINE-MODEL NO. 311707, TYPE NO. 0132-E1**

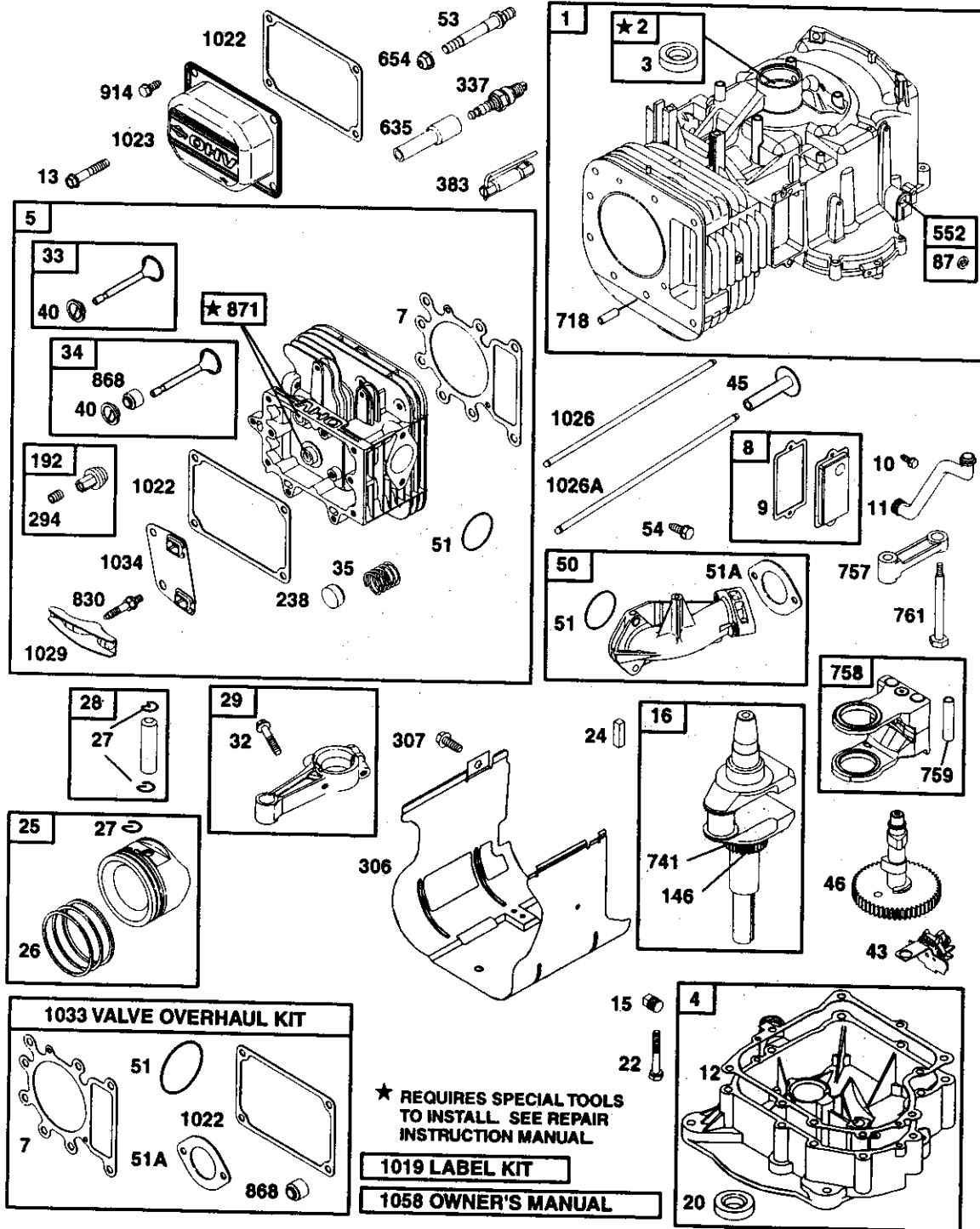

★ REQUIRES SPECIAL TOOLS TO INSTALL. SEE REPAIR INSTRUCTION MANUAL

1019 LABEL KIT

1058 OWNER'S MANUAL

**TRACTOR-- MODEL NUMBER 917.270740**  
**BRIGGS & STRATTON ENGINE-MODEL NO. 311707, TYPE NO. 0132-E1**

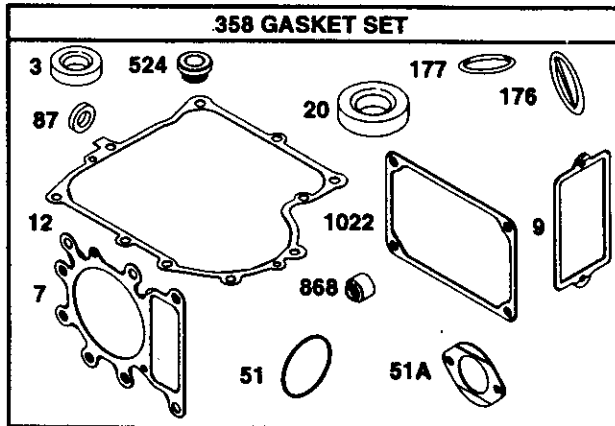
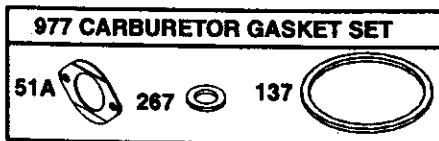
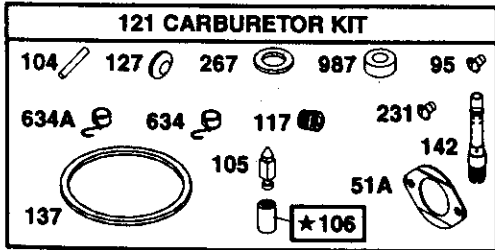
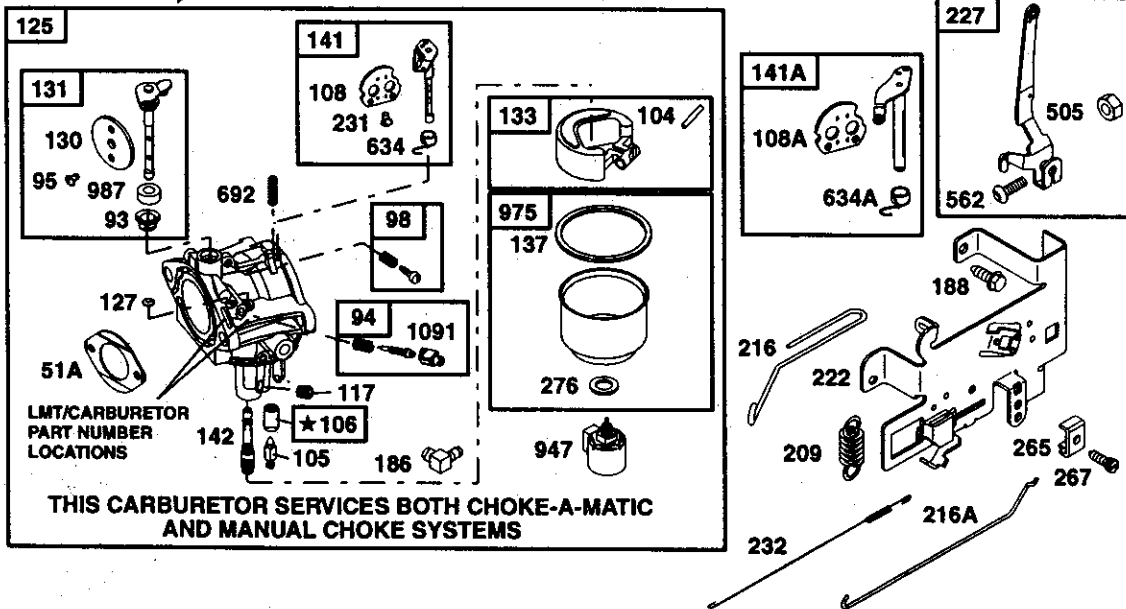
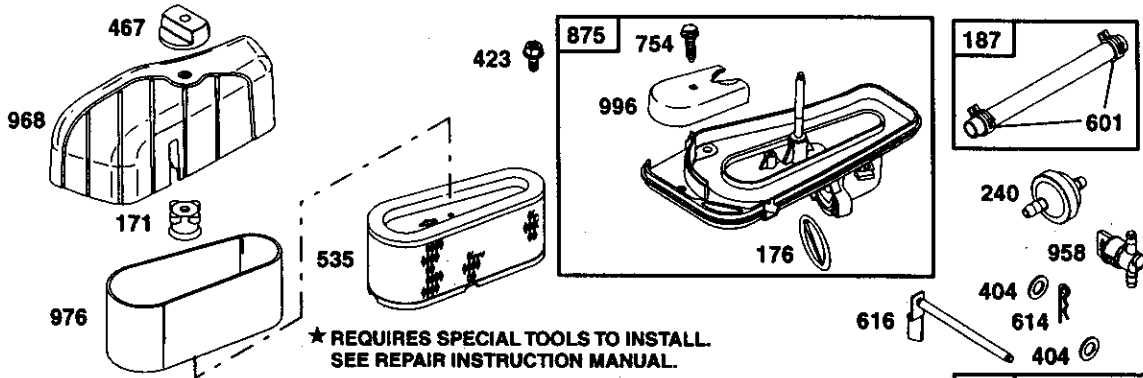

**TRACTOR-- MODEL NUMBER 917.270740**  
**BRIGGS & STRATTON ENGINE-MODEL NO. 311707, TYPE NO. 0132-E1**

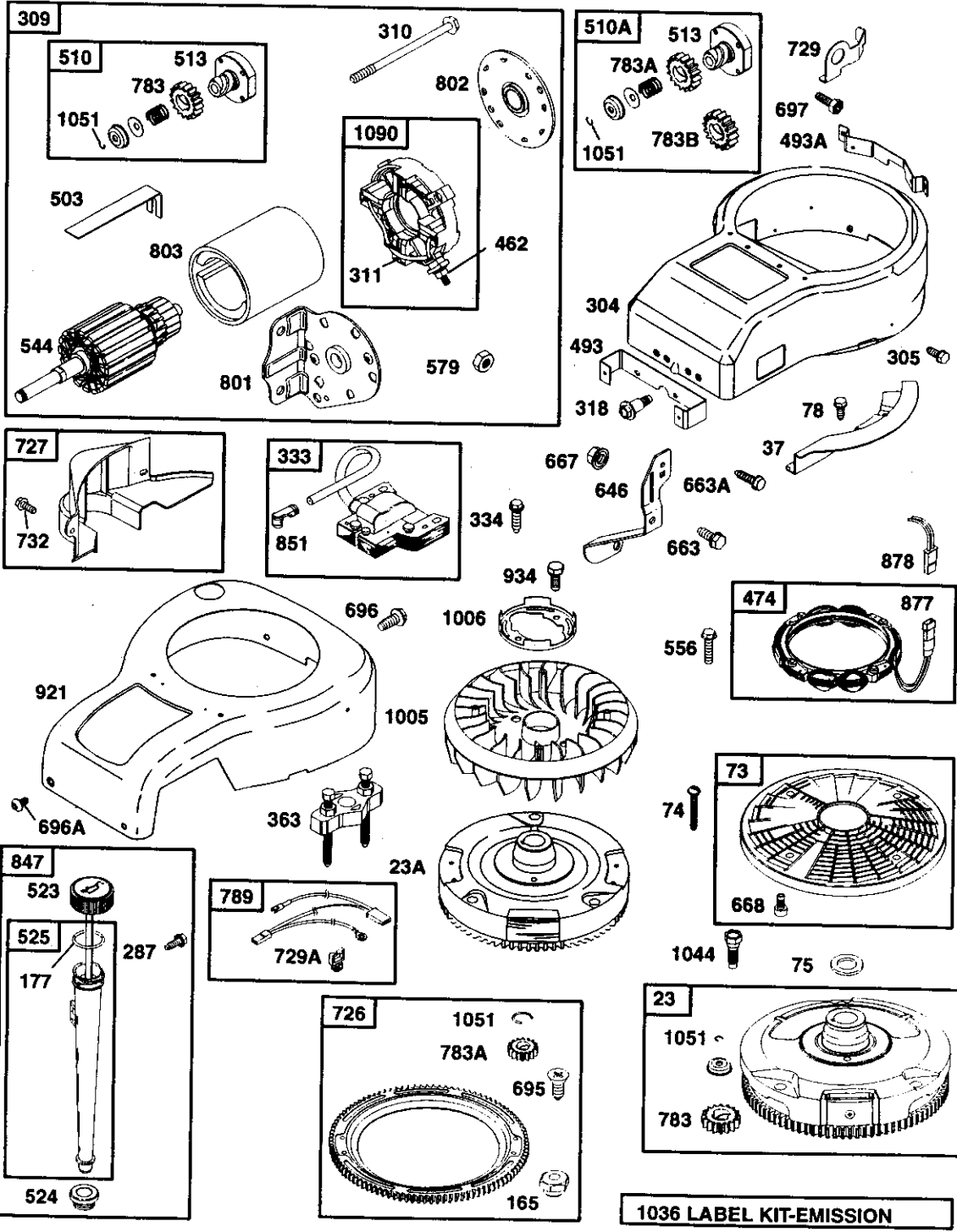

# TRACTOR -- MODEL NUMBER 917.270740

**BRIGGS & STRATTON ENGINE-MODEL NO. 311707, TYPE NO. 0132-E1**

| KEY<br>NO. | PART<br>NO. | DESCRIPTION                            | KEY<br>NO. | PART<br>NO. | DESCRIPTION                                        |
|------------|-------------|----------------------------------------|------------|-------------|----------------------------------------------------|
| 1          | 690156      | Cylinder Assembly                      | 117        | 232119      | Jet, Main (High Altitude)                          |
| 2          | 399265      | Bushing/Seal Kit                       | 121        | 690191      | Carburetor Overhaul Kit                            |
| 3          | 391086      | ★ Seal-Oil                             | 125        | 690194      | Carburetor                                         |
| 4          | 494238      | Sump-Engine                            | 127        | -----       | ● Plug-Welch (Sold in Kit Only)                    |
| 5          | 690188      | Head-Cylinder                          | 130        | 224539      | Valve-Throttle                                     |
| 7          | 692410      | ★+ Gasket-Cylinder Head                | 131        | 494379      | Throttle Shaft Kit                                 |
| 8          | 495735      | Breather Assembly                      | 133        | 494381      | Float-Carburetor                                   |
| 9          | 27803       | ★ Gasket-Breather                      | 137        | 281165      | ◆ Gasket-Float Bowl                                |
| 10         | 94621       | Screw (Breather Assembly)              | 141        | 495097      | Choke Shaft Kit (Man. Choke)                       |
| 11         | 281246      | Tube-Breather                          | 141A       | 495931      | Choke Shaft Kit (Choke-A-Matic)                    |
| 12         | 271916      | ★ Gasket-Crankcase (.015" Thick, Std.) | 142        | 232117      | ● Nozzle-Carburetor                                |
|            | 271997      | ★ Gasket-Crankcase (.005" Thick)       | 146        | 94196       | Key-Timing                                         |
|            | 271996      | ★ Gasket-Crankcase (.009" Thick)       | 163        | 281106      | ★ Gasket, Air Cleaner                              |
| 13         | 94728       | Screw (Cylinder Head, 3-9/16")         | 165        | 693148      | Nut (Ring Gear)                                    |
| 15         | 94239       | Plug-Oil Drain                         | 171        | 281051      | Nut (Air Cleaner)                                  |
| 16         | 690136      | Crankshaft                             | 177        | 270920      | ★ Seal-O-Ring                                      |
| 20         | 291675      | ★ Seal-Oil                             | 186        | 493496      | Connector-Hose                                     |
| 22         | 95187       | Screw (Crankcase Cover)                | 187        | 492790      | Line-Fuel (Cut to Required Length)                 |
| 23         | 693557      | Flywheel (Steel Ring Gear)             | 188        | 94929       | Screw (Control Bracket)                            |
| 23A        | 492326      | Flywheel (Plastic Ring Gear)           | 192        | 492160      | Adjuster, Rocker Arm                               |
| 24         | 222698      | Key-Flywheel                           | 209        | 260695      | Spring, Governor                                   |
| 25         | 692271      | Piston Assembly (Std.)                 | 216        | 262766      | Link-Choke                                         |
|            | 692272      | Piston Assembly (.010" O.S.)           | 216A       | 262767      | Link-Choke                                         |
|            | 692273      | Piston Assembly (.020" O.S.)           | 222        | 495611      | Bracket, Control                                   |
|            | 692274      | Piston Assembly (.030" O.S.)           | 227        | 493935      | Lever-Governor                                     |
| 26         | 690162      | Ring Set, Piston (Std.)                | 231        | 94098       | ● Screw (Choke)                                    |
|            | 690164      | Ring Set, Piston (.010" O.S.)          | 232        | 262785      | Spring-Link                                        |
|            | 690166      | Ring Set, Piston (.020" O.S.)          | 238        | 262836      | Cap, Valve                                         |
|            | 690168      | Ring Set, Piston (.030" O.S.)          | 240        | 394358      | Filter-Fuel                                        |
| 27         | 263129      | Lock-Piston Pin                        | 265        | 221535      | Clamp-Casing                                       |
| 28         | 498319      | Pin Assembly, Piston (Std.)            | 276        | 281164      | ◆ Sealing Washer                                   |
|            | 498320      | Pin Assembly-Piston (.005" O.S.)       | 287        | 94903       | Screw (Dipstick Tube)                              |
|            |             |                                        | 294        | 81010       | Adjuster-Rocker Arm                                |
| 29         | 692419      | Rod-Connecting (Std.)                  | 304        | 225017      | Housing-Blower (Black Inner)                       |
|            | 499940      | Rod-Connecting (.020 U.S.)             | 305        | 94863       | Screw (Inner Blower Housing)                       |
| 32         | 692852      | Screw (Connecting Rod)                 | 306        | 225020      | Shield, Cylinder                                   |
| 33         | 495856      | Valve-Exhaust                          | 307        | 94930       | Screw (Cylinder Shield)                            |
| 34         | 495857      | Valve, Intake                          | 309        | 693551      | Motor-Starter (For Steel Ring Gear Only)           |
| 35         | 262811      | Spring, Valve                          | 309        | 497595      | Motor-Starter (For Plastic Ring Gear Only)         |
| 37         | 224502      | Guard-Flywheel                         | 309        | 693054      | Motor-Starter (For Aluminum Ring Gear Only)        |
| 40         | 224641      | Retainer, Valve                        | 310        | 94003       | Screw (Starter Motor)                              |
| 43         | 490815      | Governor-Oil Slinger                   | 311        | 497608      | Brush Set                                          |
| 45         | 262411      | Tappet, Valve                          | 318        | 94734       | Screw (Mounting Bracket)                           |
| 46         | 496884      | Camshaft                               | 333        | 495859      | Armature, Magneto                                  |
| 48         | 692706      | ShortBlock                             | 334        | 94731       | Screw (Armature)                                   |
| 50         | 690193      | Manifold, Intake                       | 337        | 491055      | Spark Plug                                         |
| 51         | 693138      | ★+ Gasket-Intake                       | 358        | 690189      | Gasket Set                                         |
| 51A        | 273650      | Gasket-Intake                          | 363        | 19203       | Flywheel Puller                                    |
| 53         | 690227      | Stud (Carburetor)                      | 383        | 89838       | Wrench-Spark Plug                                  |
| 54         | 95160       | Screw (Intake Manifold)                | ★          |             | Included in Gasket Set, Ref Number 358.            |
| 73         | 494439      | Screen, Rotating                       | ●          |             | Included in Carburetor Kit, Ref Number 121.        |
| 74         | 94821       | Screw (Rotating Screen)                | ◆          |             | Included in Carburetor Gasket Set, Ref Number 977. |
| 75         | 225136      | Washer (Flywheel)                      | +          |             | Included in Valve Overhaul Kit, Ref Number 1033.   |
| 78         | 94896       | Screw (Flywheel Guard)                 |            |             |                                                    |
| 87         | 491323      | ★ Seal-Governor Shaft                  |            |             |                                                    |
| 93         | 281346      | Bushing-Throttle Shaft                 |            |             |                                                    |
| 94         | 498030      | Valve-Idle Adjustment                  |            |             |                                                    |
| 95         | 94098       | ● Screw (Throttle Valve)               |            |             |                                                    |
| 98         | 495800      | Kit-Idle Speed                         |            |             |                                                    |
| 104        | 231789      | ● Pin-Float Hinge                      |            |             |                                                    |
| 105        | 231855      | ● Valve-Float Needle                   |            |             |                                                    |
| 106        | 231854      | ● Seat-Inlet                           |            |             |                                                    |
| 108        | 224558      | Valve-Choke (Manual Choke)             |            |             |                                                    |
| 108A       | 224540      | Valve-Choke (Choke-A-Matic)            |            |             |                                                    |
| 117        | 232118      | ● Jet, Main (Standard)                 |            |             |                                                    |

**NOTE:** All component dimensions given in U.S. inches. 1 inch = 25.4 mm

# TRACTOR -- MODEL NUMBER 917.270740

BRIGGS & STRATTON ENGINE-MODEL NO. 311707, TYPE NO. 0132-E1

| KEY PART<br>NO. NO. | DESCRIPTION                                                 | KEY PART<br>NO. NO. | DESCRIPTION                                        |
|---------------------|-------------------------------------------------------------|---------------------|----------------------------------------------------|
| 404 94927           | Washer (Governor Crank)                                     | 797 693167          | Nut (Brush Retainer)                               |
| 423 95163           | Screw (Air Cleaner Base)                                    | 801 497626          | Cap-Drive                                          |
| 462 225137          | Washer (Starter Cable)                                      | 802 497607          | Cap-End                                            |
| 467 493903          | Knob-Air Cleaner                                            | 803 497604          | Housing-Starter                                    |
| 474 393474          | Alternator                                                  | 813 393514          | Clamp                                              |
| 493 224968          | Bracket-Mounting (Front)                                    | 830 94555           | Stud (Rocker Arm)                                  |
| 493A 224969         | Bracket-Mounting (Rear)                                     | 847 496415          | Dipstick/Tube Assembly                             |
| 503 806000          | Strap-Starter                                               | 851 224110          | Terminal-Wire                                      |
| 505 231978          | Nut (Governor Lever)                                        | 868 499236 ★+       | Seal -Valve                                        |
| 510A 693699         | Drive, Starter (Use With Steel Ring Gear Only)              | 872 281104          | Cover-Air Cleaner                                  |
| 510A 497606         | Drive, Starter (Use With Aluminum & Plastic Ring Gear Only) | 875 693686          | Base-Air Cleaner                                   |
| 513 398003          | Clutch-Drive                                                | 877 393537          | Wire-Alternator                                    |
| 523 495230          | Dipstick                                                    | 883 272293 ★+       | Gasket-Exhaust                                     |
| 524 281370 ★        | Dipstick Tube Seal                                          | 910 93621           | Screw (Alternator)                                 |
| 525 496113          | Dipstick Tube                                               | 914 690960          | Screw (Rocker Cover)                               |
| 535 496894          | Filter, A/C Element                                         | 934 94627           | Screw (Fan Retainer)                               |
| 544 497603          | Armature-Starter                                            | 947 497672          | Solenoid-Fuel                                      |
| 552 491986          | Bushing-Gov. Lever                                          | 967 272403          | Filter-Pre-cleaner                                 |
| 562 92613           | Bolt (Governor Lever)                                       | 975 495933          | Bowl-Float                                         |
| 579 92278           | Nut (Starter Cable)                                         | 977 690192          | Gasket Set-Carburetor                              |
| 601 93053           | Clamp-Hose                                                  | 987 281166 ●        | Seal-Throttle Shaft                                |
| 614 93306           | Pin-Cotter                                                  | 996 690678          | Shield Carburetor                                  |
| 616 495157          | Crank-Governor                                              | 1005 691927         | Fan-Flywheel                                       |
| 617 692138 ★+       | Seal-O-Ring                                                 | 1006 224413         | Retainer-Fan                                       |
| 634 494455 ●        | Spring & Seal Assy                                          | 1022 272475 ★+      | Gasket-Rocker Cover                                |
| 635 691909          | Boot-Spark Plug                                             | 1023 224552         | Cover-Rocker                                       |
| 654 94010           | Nut (Carburetor)                                            | 1026 494432         | Rod-Push (Intake)                                  |
| 668 280848          | Spacer                                                      | 1026A 495136        | Rod-Push (Exhaust)                                 |
| 695 693109          | Screw (Ring Gear)                                           | 1029 224554         | Arm-Rocker                                         |
| 697 690372          | Screw (Drive Cap)                                           | 1033 691581         | Kit-Valve Overhaul                                 |
| 718 230192          | Pin-Locating                                                | 1034 690822         | Guide-Push Rod                                     |
| 726 399676          | Gear-Ring (Aluminum-Services Plastic Ring Gear Only.)       | 1036 499364         | Label Kit-Emission                                 |
| 726A -----          | Gear-Ring (Steel-See Ref. 23A for Service.)                 | 1044 94673          | Screw (Crankshaft Extension)                       |
| 727 490324          | Cover-Starter Drive                                         | 1051 263080         | Ring-Retaining                                     |
| 729 225170          | Clip-Wire                                                   | 1058 273683         | Owner's Manual                                     |
| 729A 281390         | Clip-Wire                                                   | 1081 270920 ★       | Seal O Ring                                        |
| 732 691002          | Screw (Starter Drive Cover)                                 | 1090 497605         | Retainer-Brush                                     |
| 741 262932          | Gear-Timing                                                 | 1091 281364         | Cap-Limiter                                        |
| 754 690703          | Screw (Breather Baffle)                                     | --- 311707-0026-E1  | Replacement Engine                                 |
| 757 213998          | Link-Counterweight                                          | ★                   | Included in Gasket Set, Ref Number 358.            |
| 758 499994          | Counterweight                                               | ●                   | Included in Carburetor Kit, Ref Number 121.        |
| 759 230787          | Pin-Counterweight                                           | ◆                   | Included in Carburetor Gasket Set, Ref Number 977. |
| 761 94593           | Screw (Counterweight)                                       | +                   | Included in Valve Overhaul Kit, Ref Number 1033.   |
| 783 693713          | Gear-Pinion (For Steel Ring Gear Only)                      |                     |                                                    |
| 783A 693059         | Gear-Starter (For Aluminum Ring Gear Only)                  |                     |                                                    |
| 783B 693058         | Gear-Starter (For Plastic Ring Gear Only)                   |                     |                                                    |
| 789 497708          | Harness-Wiring                                              |                     |                                                    |

**NOTE:** All component dimensions given in U.S. inches. 1 inch = 25.4 mm







# SUGGESTED GUIDE FOR SIGHTING SLOPES FOR SAFE OPERATION

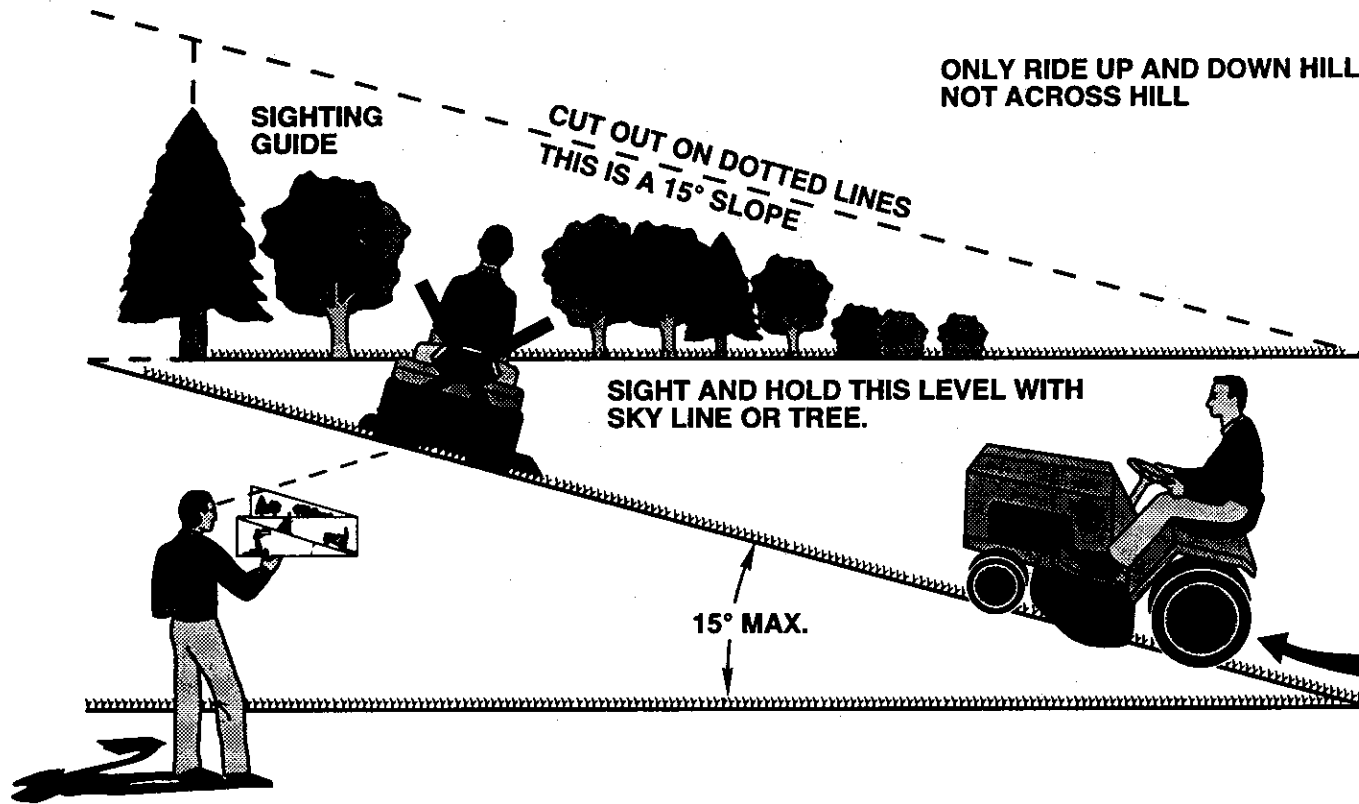

Operate your Tractor up and down the face of slopes (not greater than 15°), never across the face. Make turns gradually to prevent tipping or loss of control. Exercise extreme caution when changing direction on slopes.

**For in-home major brand repair service:**

Call 24 hours a day, 7 days a week

**1-800-4-MY-HOME<sup>SM</sup>** (1-800-469-4663)

**Para pedir servicio de reparación a domicilio**

**1-800-676-5811**

In Canada for all your service and parts needs call

Au Canada pour tout le service ou les pièces

**1-800-665-4455**

**For the repair or replacement parts you need:**

Call 6 am - 11 pm CST, 7 days a week

**PartsDirect<sup>SM</sup>**

**1-800-366-PART** (1-800-366-7278)

**Para ordenar piezas con entrega a domicilio**

**1-800-659-7084**

**For the location of a Sears Parts and Repair Center  
in your area:**

Call 24 hours a day, 7 days a week

**1-800-488-1222**

**For information on purchasing a Sears Maintenance  
Agreement or to inquire about an existing Agreement:**

Call 9 am - 5 pm, Monday - Saturday

**1-800-827-6655**

