

PRO-FORM[®] 900L

PERFORMANCE CYCLE

Model No. 831.288230

Serial No _____

The serial number is found in the location shown below. Write the serial number in the space above.

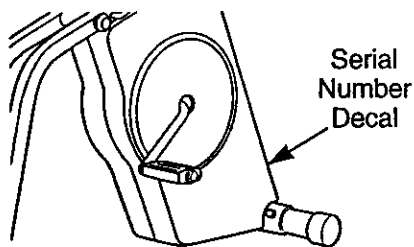

EXERCISE
EQUIPMENT

QUESTIONS

HELPLINE!

1-800-736-6879

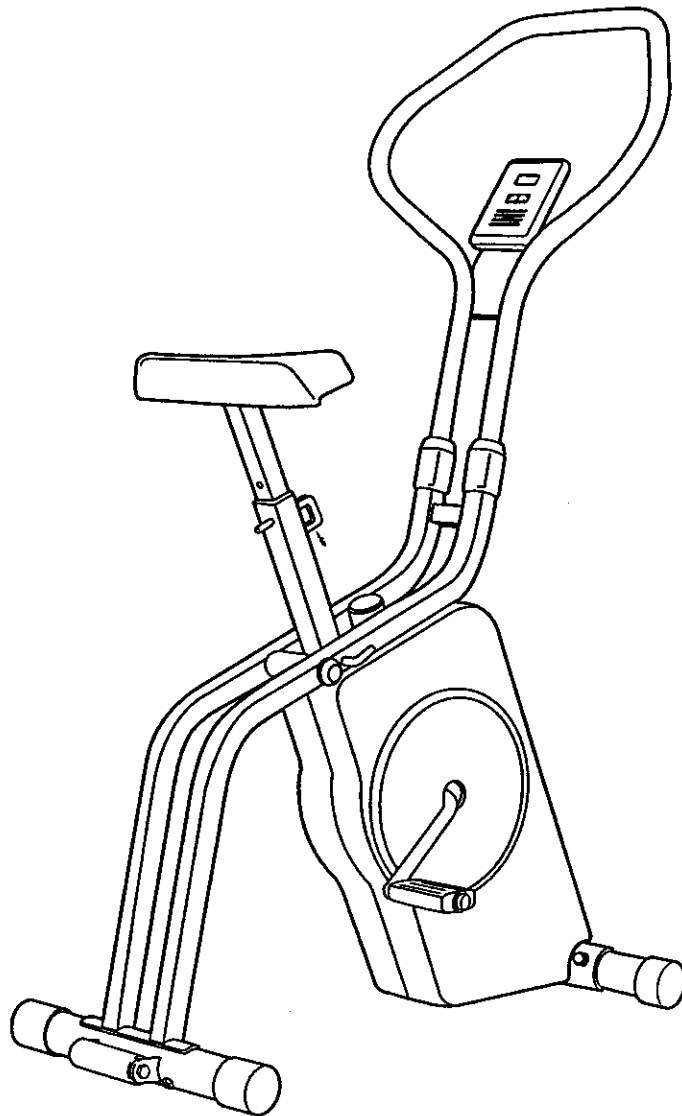

CAUTION

Read all precautions and instructions in this manual before using this equipment. Keep this manual for future reference.

USER'S MANUAL

SEARS, ROEBUCK AND CO., HOFFMAN ESTATES, IL 60179

TABLE OF CONTENTS

IMPORTANT PRECAUTIONS	2
BEFORE YOU BEGIN	3
ASSEMBLY	4
HOW TO USE THE EXERCISE CYCLE	6
STORAGE AND TROUBLE-SHOOTING	7
CONDITIONING GUIDELINES	9
PART LIST	10
EXPLODED DRAWING	11
HOW TO ORDER REPLACEMENT PARTS	Back Cover
FULL 90-DAY WARRANTY	Back Cover

IMPORTANT PRECAUTIONS

WARNING: To reduce the risk of serious injury, read the following important precautions before using the exercise cycle.

1. Read all instructions in this manual before using the exercise cycle. Use the exercise cycle only as described.
2. It is the responsibility of the owner to ensure that all users of the exercise cycle are adequately informed of all precautions.
3. Use the exercise cycle indoors, away from moisture and dust. Place the exercise cycle on a level surface, with a mat beneath it to protect the floor or carpet from damage.
4. Inspect and tighten all parts regularly. Replace any worn parts immediately.
5. Keep children under the age of 12 and pets away from the exercise cycle at all times.
6. The exercise cycle should not be used by persons weighing more than 250 pounds.
7. Wear appropriate clothing when exercising; do not wear loose clothing that could become caught on the exercise cycle. Always wear athletic shoes for foot protection.
8. When adjusting the seat, insert the seat pin through one of the holes in the seat post (see the drawing on page 3). Do not insert the seat pin under the seat post.
9. Make sure that the seat pin is inserted into the front of the frame and the seat post. Never insert the seat pin into the back of the frame.
10. Always keep your back straight when using the exercise cycle. Do not arch your back.
11. If you feel pain or dizziness at any time while exercising, stop immediately and begin cooling down.
12. The exercise cycle is intended for in-home use only. Do not use the exercise cycle in any commercial, rental, or institutional setting.

WARNING: Before beginning this or any exercise program, consult your physician. This is especially important for persons over the age of 35 or persons with pre-existing health problems. Read all instructions before using. SEARS assumes no responsibility for personal injury or property damage sustained by or through the use of this product.

BEFORE YOU BEGIN

Thank you for selecting the new PROFORM® 900L exercise cycle. The PROFORM 900L blends advanced engineering with contemporary styling to provide you with a low-impact workout in the convenience and privacy of your own home.



For your benefit, read this manual carefully before you use the PROFORM 900L. If you have questions after reading the manual, please call our toll-free HELPLINE at 1-800-736-6879, Monday through

Saturday, 7 a.m. until 7 p.m. Central Time (excluding holidays). To help us assist you, please mention the product model number and serial number when calling. The model number is 831.288230. The serial number can be found on a decal attached to the PROFORM 900L (see the front cover of this manual for the location of the decal).

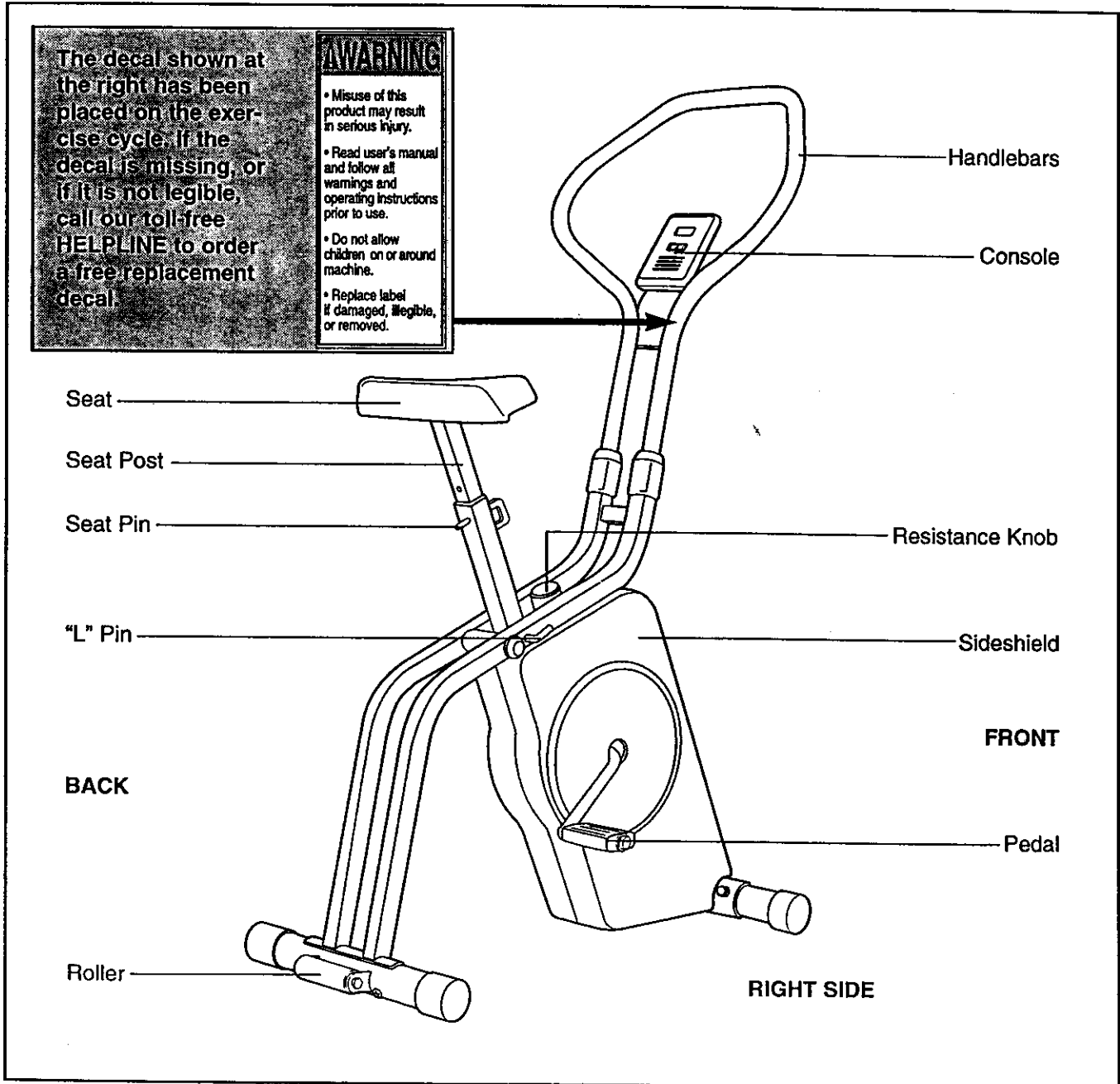
Before reading further, please familiarize yourself with the parts that are labeled in the drawing below.



ASSEMBLY

Place all parts of the exercise cycle in a cleared area and remove the packing materials. Do not dispose of the packing materials until assembly is completed. **Assembly requires the included allen wrench** , **a phillips screwdriver** , and **two adjustable wrenches** .

1. Pivot the Scissor Frame (3) and the Frame (1) to the position shown. Insert the "L" Pin (56) through one side of Scissor Frame using the indicated holes and secure it with the Spring Clip (52).

Hold the Front Stabilizer (2) against the saddle on the Frame (1), with the square holes facing away from the saddle. Attach the Front Stabilizer with two Carriage Bolts (5) and two M8 Locknuts (39).

2. Attach the Rear Stabilizer (46) to the saddle on the Scissor Frame (3) with two Carriage Bolts (5) and two M8 Locknuts (39).

3. Insert the Seat Post (20) into the Frame (1). Align one of the holes in the Seat Post with the hole in the Frame. Insert the Seat Pin (16) through the Frame and the Seat Post to select the desired seat height. **Make sure to insert the Seat Pin through one of the holes in the Seat Post; do not insert the Seat Pin under the Seat Post.**

Next, attach the Seat (21) to the Seat Post (20) with three M8 Washers (47) and three M8 Locknuts (39). Note: The Seat Washers and Locknuts may be pre-attached to the bottom of the Seat.

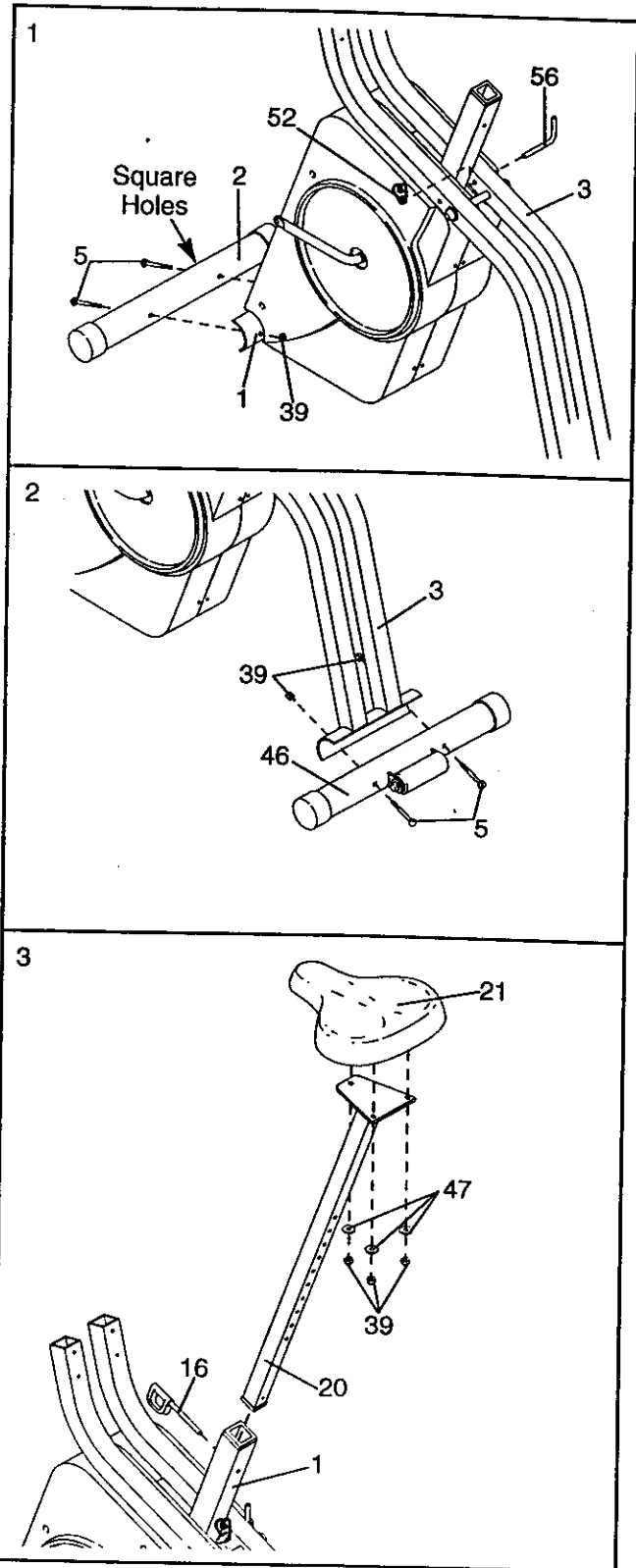

4. Slide the Handlebar Collars (12) onto the Handlebars (6). Attach the Handlebars to the Scissor Frame (3) with eight M5 x 12mm Screws (19). Next, slide the Handlebar Collars down over the Screws.

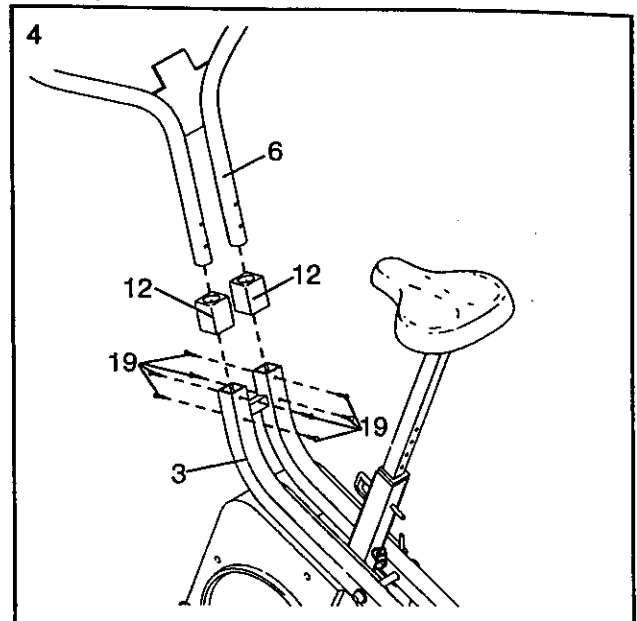

5. The Console (48) requires two AA batteries (not included). Alkaline batteries are recommended. Refer to the inset drawing. Remove the battery door from the Console. Press two batteries into the battery compartment. Make sure that the negative ends of the batteries (marked “-”) are touching the springs in the battery compartment. Reattach the battery door.

Slide the Console (48) onto the console plate. Make sure that the plastic clip on the back of the Console snaps into the tab on the console plate.

Connect the console wire to the Reed Switch Wire (49).

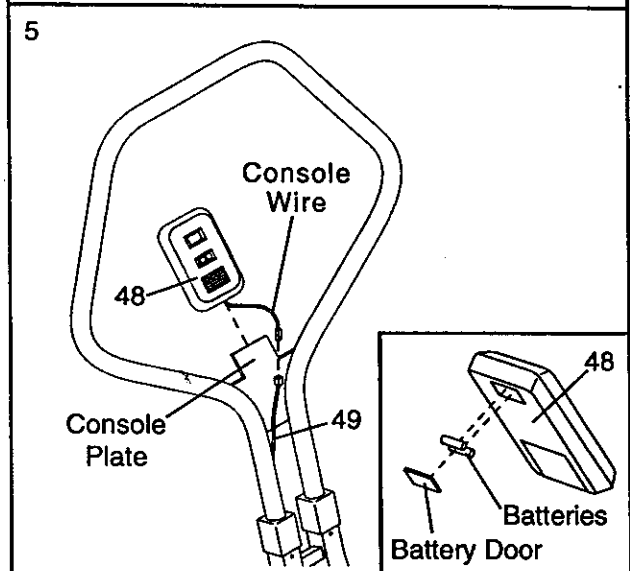

6. Identify the Left Pedal (8). (The Left Pedal is marked with an “L.”) Using an adjustable wrench, tighten the Left Pedal *counterclockwise* into the left arm of the Crank (53).

Tighten the Right Pedal (9) (not shown) *clockwise* into the Right arm on the Crank.

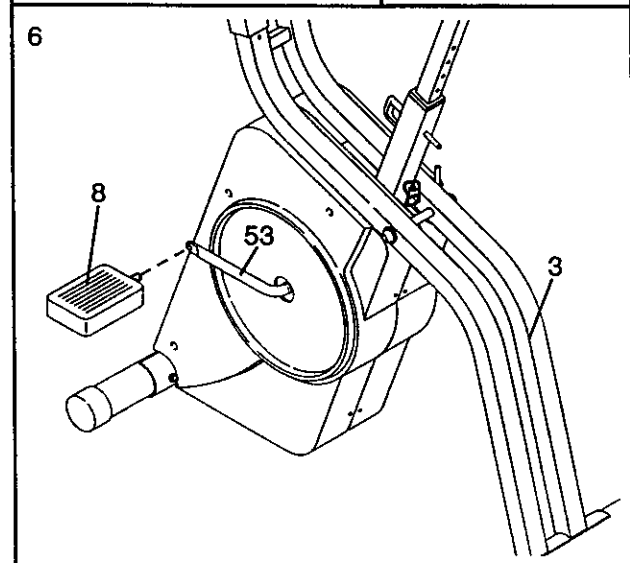

7. Make sure that all parts are properly tightened before you use the exercise cycle.

HOW TO USE THE EXERCISE CYCLE

HOW TO ADJUST THE SEAT

For effective exercise, the Seat (21) should be at the proper height. As you pedal, there should be a slight bend in your knees when the pedals are in the lowest position. To adjust the Seat, first hold the Seat and

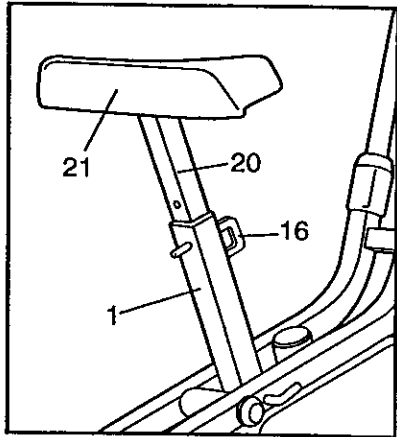

remove the Seat Pin (16). Align one of the holes in the Seat Post (20) with the hole in the Frame (1). Insert the Seat Pin into the Frame and the Seat Post. **Caution: Make sure to insert the Seat Pin through one of the holes in the Seat Post; do not insert the Seat Pin under the Seat Post. In addition, make sure that the Seat Pin is inserted into the front of the Frame and the Seat Post as shown above.**

HOW TO ADJUST THE PEDALING RESISTANCE

To vary the intensity of your exercise, the pedaling resistance can be adjusted. The resistance is controlled with the Resistance Knob (27). To increase the resistance, turn the Resistance Knob clockwise; to decrease the resistance, turn the Resistance Knob counterclockwise.

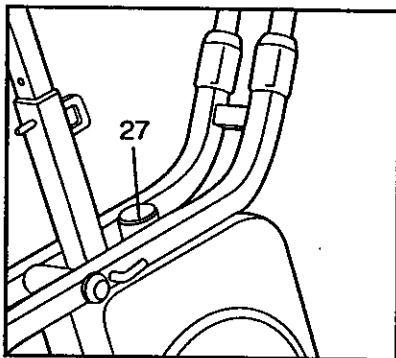

BATTERY INSTALLATION

Before the console can be operated, two "AA" batteries must be installed. If you have not installed batteries, see assembly step 5 on page 5.

DESCRIPTION OF THE CONSOLE

The console features five modes that provide instant exercise feedback during your workouts. The modes are described below.

- Speed—Displays your pedaling speed, in miles per hour.
- Time—Displays the elapsed time. Note: If you stop pedaling for ten seconds or longer, the time mode will pause until you resume.

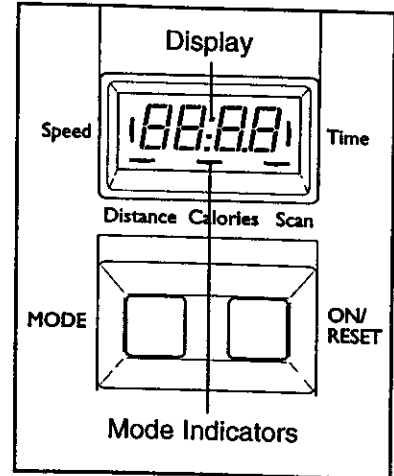

- Distance—Displays the total distance you have pedaled, in miles.
- Calorie—Displays the approximate number of Calories you have burned.
- Scan—Displays the speed, time, distance, and calorie modes, for 5 seconds each, in a repeating cycle.

HOW TO OPERATE THE CONSOLE

1. To turn on the power, press the on/reset button or simply begin pedaling. When the power is turned on, the entire display will appear for two seconds. The console will then be ready for operation.
2. Select one of the five modes:

Scan mode—When the power is turned on, the scan mode will automatically be selected. One mode indicator will

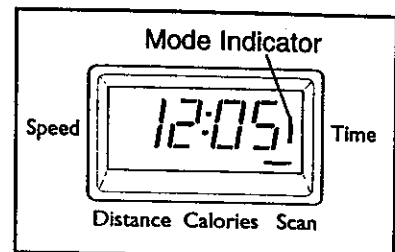

show that the scan mode is selected, and a flashing mode indicator will show which mode is currently displayed. Note: If a different mode is selected, you can select the scan mode again by repeatedly pressing the mode button.

Speed, time, distance or calorie mode— To select one of these modes for continuous display, press the mode button repeatedly. The mode indicators will show which mode is selected. Make sure that the scan mode is not selected.

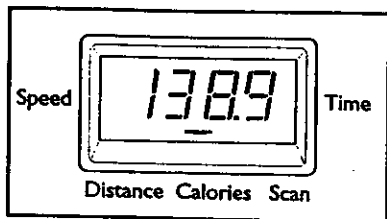

3. To reset the display, press the on/reset button.
4. To turn off the power, simply wait for about four minutes. **Note:** The monitor has an "auto-off" feature. If the pedals are not moved and the monitor buttons are not pressed for four minutes, the power will turn off automatically in order to conserve the batteries.

STORAGE AND TROUBLE-SHOOTING

Inspect and tighten all parts of the exercise cycle regularly. Replace any worn parts immediately.

The exercise cycle can be cleaned with a soft, damp cloth. Avoid spilling liquid on the console. Keep the console out of direct sunlight or the display may be damaged. Remove the batteries when storing the exercise cycle.

HOW TO STORE THE EXERCISE CYCLE

When the exercise cycle is not in use, it can be folded for compact storage. Remove the Spring Clip (52) and then pull out the "L" Pin (56). Next, fold the exercise cycle by bringing the seat and handlebars toward one another. Store the exercise cycle indoors, away from moisture and dust.

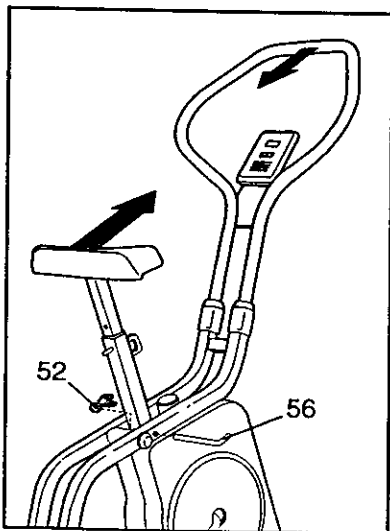

HOW TO ADJUST THE REED SWITCH

If the console does not display correct feedback, the reed switch should be adjusted. In order to adjust the reed switch, the Left Side Shield (10) must be

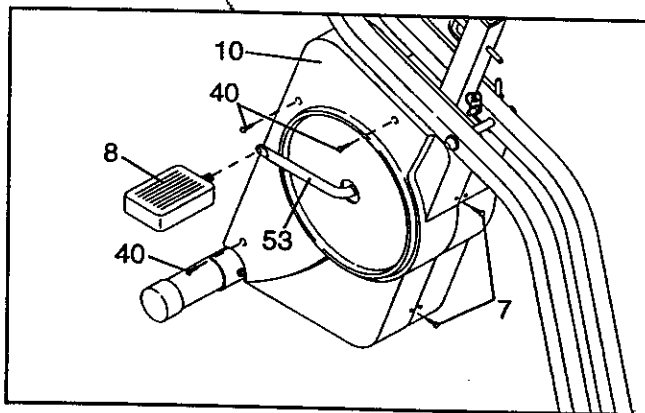

removed. Using an adjustable wrench, turn the Left Pedal (8) clockwise and remove it from the Crank (53). Remove the three M4 x 12mm Screws (40) and the two M4 x 16mm Screws (7) from the Left Side Shield. Make sure that the arm of the Crank is in the position shown in the drawing above. Carefully slide the Left Side Shield forward off the arm of the Crank and remove it.

BATTERY REPLACEMENT

If the console does not function properly, the batteries should be replaced. See assembly step 5 on page 5. In addition, make sure that the console wire is connected to the reed switch wire.

Next, locate the Reed Switch (49). Turn the Crank (53) until the Magnet (4) is aligned with the Reed Switch. Loosen but do not remove the M4 x 16mm Screw (7). Slide the Reed Switch slightly closer to or away from the Magnet. Retighten the Screw. Turn the Crank for a moment. Repeat until the console displays correct feedback. When the Reed Switch is correctly adjusted, reattach the left side shield and pedal.

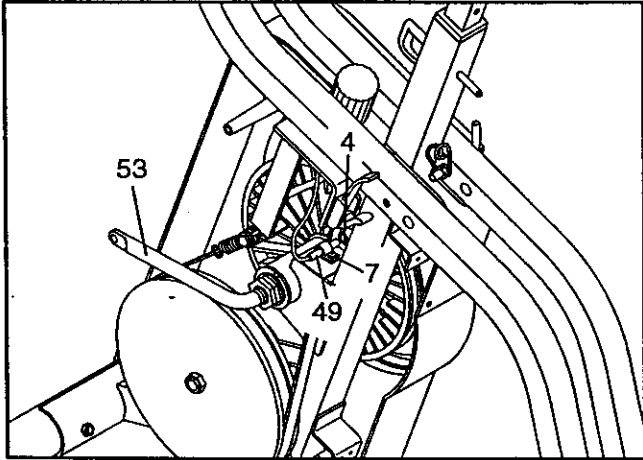

HOW TO ADJUST THE RESISTANCE STRAP

If there is not enough pedaling resistance when the resistance knob is turned to the highest setting, the Resistance Strap (15) may need to be adjusted. To adjust the Resistance Strap, the left side shield must first be removed. Refer to the instructions on page 7 and remove the left side shield.

Next, turn the resistance knob to the lowest setting. Locate and open the Strap Clamp (38). Grip the end of the Resistance Strap (15) and pull it up slightly. While holding the end of the Resistance

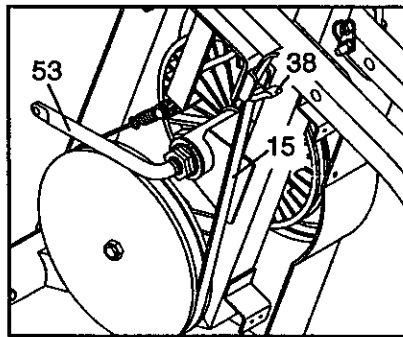

Strap, **fully** close the Strap Clamp. Turn the Crank (53) for a moment to make sure that there is not too much resistance. When the Resistance Strap is properly adjusted, reattach the left side shield and pedal.

HOW TO ADJUST THE DRIVE BELT

The exercise cycle features a precision drive belt that must be kept properly adjusted. If the belt causes excessive noise or slips as you pedal, the belt should be checked. To do this, the side shields must first be removed. Refer to the instructions on page 7 and remove the left side shield. Next, remove the right side shield in the same way.

Press down on the center of the Drive Belt (14) between the front and rear pulleys. There should be from 1/4" to 1/2" of movement in the center of the Belt.

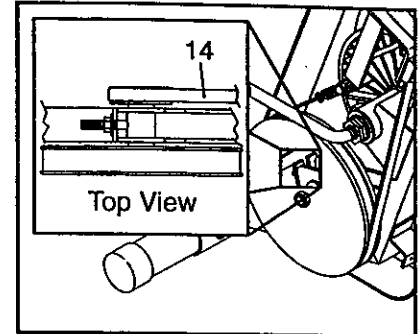

If the Drive Belt (14) is properly adjusted, reattach the side shields and pedals. If the Belt needs to be adjusted, loosen the Nylon Locknut (54) on the left side of the Flywheel (29). To tighten the Belt, turn the Adjustment Nut (30) clockwise; to loosen the Belt, turn the Adjustment Nut counterclockwise. Make sure that the Flywheel is straight and tighten the Nylon Locknut (54). Reattach the side shields and pedals.

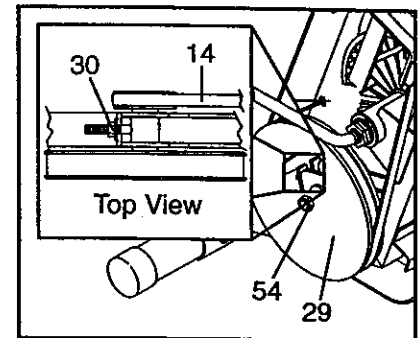

CONDITIONING GUIDELINES

The following guidelines will help you to plan your exercise program. Remember that proper nutrition and adequate rest are essential for successful results.

WARNING: Before beginning this or any exercise program, consult your physician. This is especially important for persons over the age of 35 or persons with pre-existing health problems.

EXERCISE INTENSITY

Whether your goal is to burn fat or to strengthen your cardiovascular system, the key to achieving the desired results is to exercise with the proper intensity. The proper intensity level can be found by using your heart rate as a guide. The chart below shows recommended heart rates for fat burning, maximum fat burning, and cardiovascular (aerobic) exercise.

HEART RATE TRAINING ZONES				
AGE	♥ MIN BPM		MAX BPM ♥	AGE
20	125	145	165	20
30	120	138	155	30
40	115	130	145	40
50	110	125	140	50
60	105	118	130	60
70	95	110	125	70
80	90	103	115	80
	Fat Burn	Max Burn	Aerobic	

To find the proper heart rate for you, first find your age on either side of the chart (ages are rounded off to the nearest ten years). Next, find the three numbers to the side of your age. The three numbers are your "training zone." The lowest number is the recommended heart rate for fat burning; the middle number is the heart rate for maximum fat burning; the highest number is the heart rate for aerobic exercise.

Burning Fat

To burn fat effectively, you must exercise at a relatively low intensity level for a sustained period of time.

During the first few minutes of exercise, your body uses easily accessible *carbohydrate* calories for energy. Only after the first few minutes of exercise does your body begin to use stored *fat* calories for energy. If your goal is to burn fat, adjust the intensity of your exercise until your heart rate is near the lowest number in your training zone as you exercise.

For maximum fat burning, adjust the intensity of your exercise until your heart rate is near the middle number in your training zone as you exercise.

Aerobic Exercise

If your goal is to strengthen your cardiovascular system, your exercise must be "aerobic." Aerobic exercise is activity that requires large amounts of oxygen for prolonged periods of time. This increases the demand on the heart to pump blood to the muscles, and on the lungs to oxygenate the blood. For aerobic exercise, adjust the intensity of your exercise until your heart rate is near the highest number in your training zone.

HOW TO MEASURE YOUR HEART RATE

To measure your heart rate, first exercise for at least four minutes. Then, stop exercising and place two fingers on your wrist as shown. Take a six-second heartbeat count, and multiply the result by 10 to find your heart rate. For example, if your six-second heartbeat count is 14, your heart rate is 140 beats per minute. (A six-second count is used because your heart rate will drop rapidly when you stop exercising.)

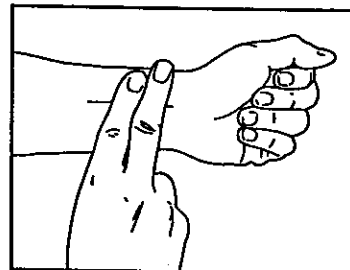

WORKOUT GUIDELINES

Each workout should include the following three parts:

A warm-up, consisting of 5 to 10 minutes of stretching and light exercise. A proper warm-up increases your body temperature, heart rate, and circulation in preparation for exercise.

Training zone exercise, consisting of 20 to 30 minutes of exercising with your heart rate in your training zone. (During the first few weeks of your exercise program, do not keep your heart rate in your training zone for longer than 20 minutes.)

A cool-down, with 5 to 10 minutes of stretching. This will increase the flexibility of your muscles and will help to prevent post-exercise problems.

EXERCISE FREQUENCY

To maintain or improve your condition, plan three workouts each week, with at least one day of rest between workouts. After a few months of regular exercise, you may complete up to five workouts each week, if desired. **Caution: Be sure to progress at your own pace and avoid overdoing it. Incorrect or excessive training may result in injury to your health.**

Remember, the key to success is make exercise a regular and enjoyable part of your everyday life.

PART LIST—Model No. 831.288230

R1098A

Key No.	Qty.	Description	Key No.	Qty.	Description
1	1	Frame	31	1	Adjustment Sleeve
2	1	Front Stabilizer	32	2	Flywheel Bushing
3	1	Scissor Frame	33	1	Flywheel Pulley/Axle
4	1	Magnet	34	2	Axle Cap
5	4	Carriage Bolt	35	2	M4 x 12mm Screw
6	1	Handlebar	36	1	Scissor Axle
7	5	M4 x 16mm Screw	37	2	Crank Nut
8	1	Left Pedal	38	1	Strap Clamp
9	1	Right Pedal	39	7	M8 Locknut
10	1	Left Side Shield	40	3	M4 x 12mm Screw
11	1	Right Side Shield	41	1	Tension Spring
12	2	Handlebar Collar	42	1	Clamp Screw
13	4	Endcap	43	1	Resistance Spring
14	1	Drive Belt	44	4	1/4" Washer
15	1	Resistance Strap	45	1	Clamp Nut
16	1	Seat Pin	46	1	Rear Stabilizer
17	1	Frame Bushing	47	3	M8 Washer
18	1	Seat Post Bushing	48	1	Console
19	8	M5 x 12mm Screw	49	1	Reed Switch w/Wire
20	1	Seat Post	50	1	M5 x 16mm Flat Head Screw
21	1	Seat	51	1	M10 Washer
22	1	Large Pulley	52	1	Spring Clip
23	2	Push Nut	53	1	Crank
24	1	Roller Axle	54	1	1/2-13 UNC Nylon Locknut
25	1	Roller	55	1	Reed Switch Clamp
26	1	Bearing Assembly	56	1	"L" Pin
27	1	Resistance Knob	57	2	Scissor Frame Spacer
28	1	Resistance Control/Cable	58	1	Scissor Frame Sleeve
29	1	Flywheel	#	1	User's Manual
30	1	M10 Nylon Locknut			

Note: "#" refers to a non-illustrated part. Specifications are subject to change without notice. See the back cover of this manual for information about ordering replacement parts.

EXPLODED DRAWING—Model No. 831.288230

R1098A

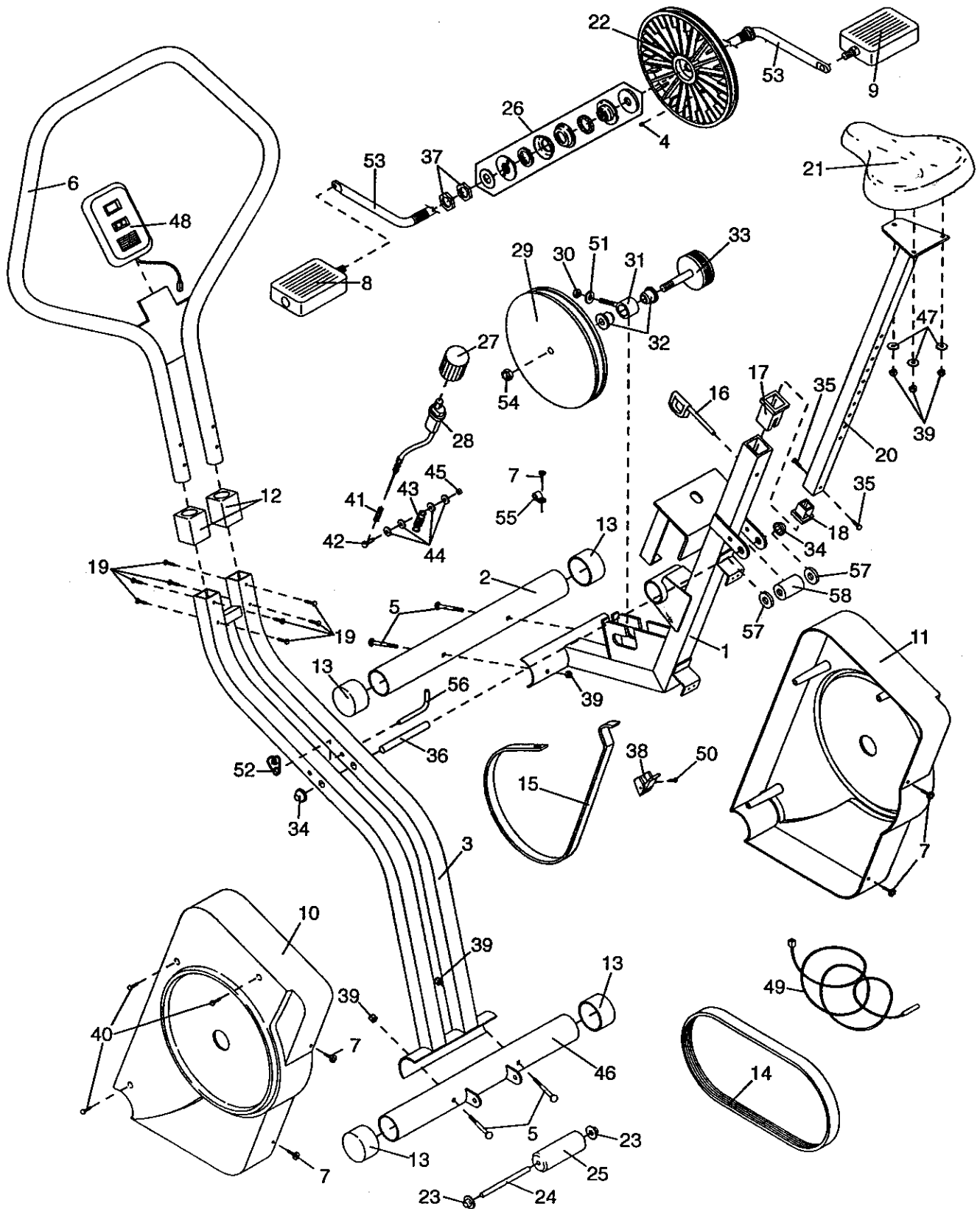



Model No. 831.288230

QUESTIONS?

If you find that:

- you need help assembling or operating the PROFORM® 900L
- a part is missing
- or you need to schedule repair service

call our toll-free HELPLINE

1-800-736-6879

Monday–Saturday, 7 am–7 pm
Central Time (excluding holidays)

REPLACEMENT PARTS

If parts become worn and need to be replaced, call the following toll-free number

1-800-FON-PART
(1-800-366-7278)

The model number and serial number of your PROFORM® 900L are listed on a decal attached to the frame. See the front cover of this manual to find the location of the decal.

All replacement parts are available for immediate purchase or special order when you visit your nearest SEARS Service Center. To request service or to order parts by telephone, call the toll-free numbers listed at the left.

When requesting help or service, or ordering parts, please be prepared to provide the following information:

- The MODEL NUMBER of the product (831.288230).
- The NAME of the product (PROFORM® 900L).
- The KEY NUMBER and DESCRIPTION of the PART (see the PART LIST and the EXPLODED DRAWING on pages 10 and 11).

FULL 90 DAY WARRANTY

For 90 days from the date of purchase, if failure occurs due to defect in material or workmanship in this SEARS BIKE EXERCISER, contact the nearest SEARS Service Center throughout the United States and SEARS will repair or replace the BIKE EXERCISER, free of charge.

This warranty does not apply when the BIKE EXERCISER is used commercially or for rental purposes.

This warranty gives you specific legal rights, and you may also have other rights which vary from state to state.

SEARS, ROEBUCK AND CO., DEPT. 817WA, HOFFMAN ESTATES, IL 60179