

Panasonic

DVD/VIDEO CD/CD PLAYER

Operating Instructions

Model No. **DVD-RV65**

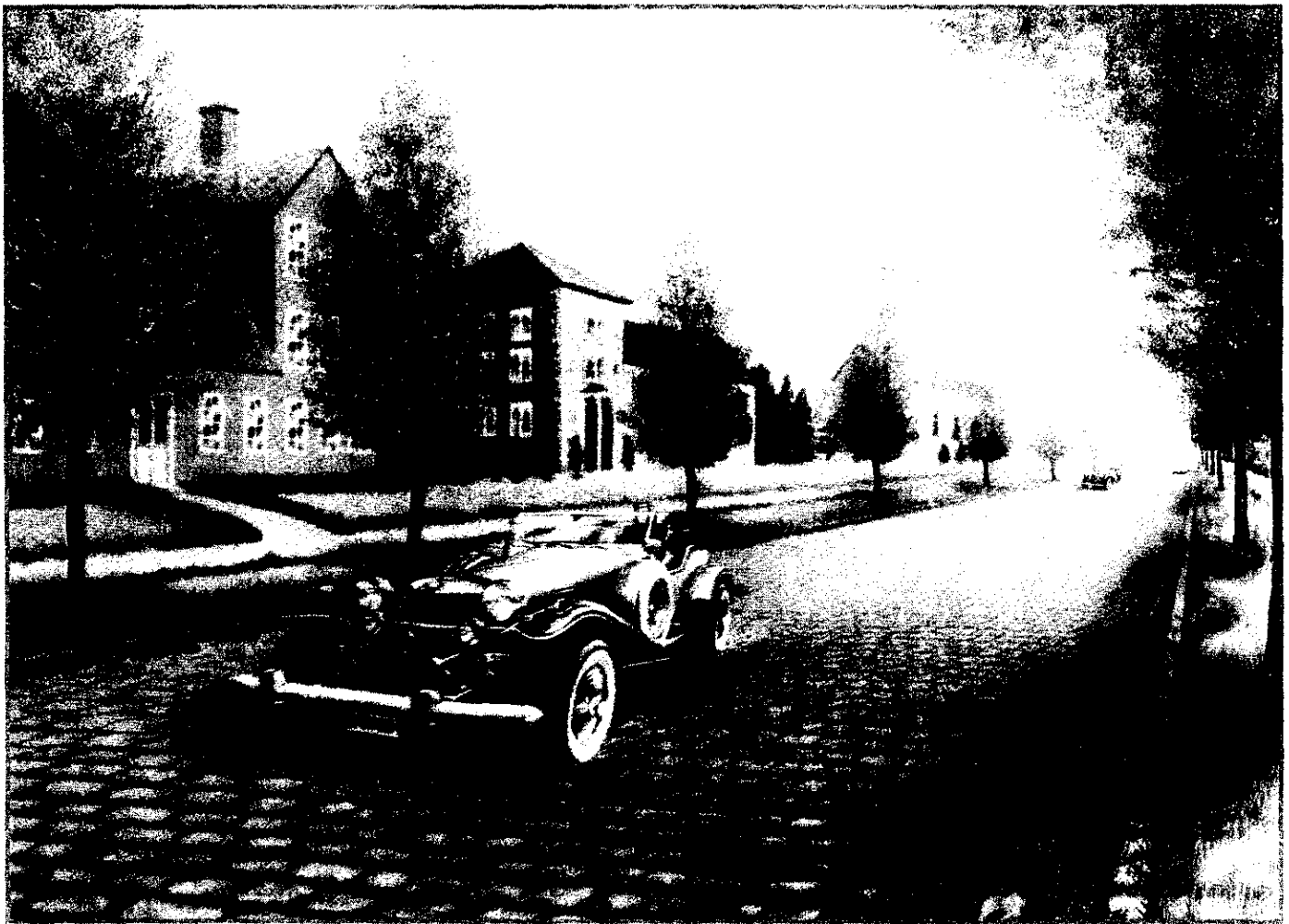

Before connecting, operating or adjusting this product, please read these instructions completely.
Please keep this manual for future reference.

Dear customer

Thank you for purchasing this product.
For optimum performance and safety, please read these instructions carefully.

Marks used in these operating instructions

- DVD** : indicates features applicable to DVD only.
- VCD** : Video CD only.
- CD** : Audio CD only.

Accessories



Please check and identify the supplied accessories.
Use numbers indicated in parentheses when asking for replacement parts.

(Only for U.S.A.)

To order accessories contact 1-800-332-5368 or web site (<http://www.panasonic.com>)

(Only for Canada)

To order accessories, call the dealer from whom you have made your purchase.



- Remote control 1
(VEQ2377)

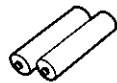

- Batteries 2
for remote control



- AC power supply cord 1
(RJA0065-A)

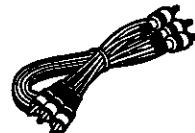

- Audio/video cable 1
(VJA0788-D)

Optional accessories

- S video cable (⇒ page 8.)
- Optical digital audio cable (⇒ pages 34 and 35.)
- Coaxial audio cable (⇒ pages 34 and 35.)

Note

- The included AC power supply cord is for use with this unit only.
Do not use it with other equipment.

User memo:

DATE OF PURCHASE _____ DEALER NAME _____ DEALER ADDRESS _____ _____ TELEPHONE NUMBER _____
--

The model number and serial number of this product can be found on either the back or the bottom of the unit. Please note them in the space provided below and keep for future reference. MODEL NUMBER _____ DVD-RV65 _____ SERIAL NUMBER _____
--

Table of contents

Getting started

Accessories	2
SAFETY INFORMATION	3
PRECAUTIONS	4
Control reference guide	5
Disc information	6
Disc handling	7
Maintenance	7
Remote control preparations	7
Connection to a television	8

Basic operations

Basic play	11
Stopping play	12
Other methods of play	13
Still picture (Pause)	13
Skipping chapters or tracks	13
Frame advance (Frame reverse)	13
Slow-motion play	14
Rapid advance (Rapid reverse)	14
Starting play from a selected title or track	15
Using menus to play	15

Advanced operations

Advanced operations	16
Changing soundtrack language	16
Changing subtitle language	17
Viewing from another angle	17
Repeat play	18
Repeating sections between two specific points (A-B repeat)	18
Changing picture quality for movie viewing	19
Raising dialogue volume	19
Program play	20
Random play	21
Reproducing an advanced Virtual Surround Sound (V.S.S.) effect	22
Using On-Screen Menu Icons	23
Common procedures	23
Detailed descriptions of each icon	24
Changing initial settings	26
Common procedures	26
1 Disc Languages	27
2 Ratings	28
3 Menu Language	29
4 On-Screen Messages	29
5 FL Display	29
9 Other Settings	30
How different kinds of software appear on your television	31

Home theater

Home theater	32
Connecting an amplifier with 5.1-channel audio input terminals	33
Connecting an amplifier with built-in decoder	34
Connecting audio equipment with digital audio input terminals	35
Connecting audio equipment with 2-channel audio input terminals	35
Selecting digital output	36
Speaker Setting	38

For your reference

Troubleshooting Guide	40
Product Service	41
Servicenter List (US)	42
Specifications	43

SAFETY INFORMATION

CAUTION!

THIS PRODUCT UTILIZES A LASER.
 USE OF CONTROLS OR ADJUSTMENTS OR PERFORMANCE OF PROCEDURES OTHER THAN THOSE SPECIFIED HEREIN MAY RESULT IN HAZARDOUS RADIATION EXPOSURE.
 DO NOT OPEN COVERS AND DO NOT REPAIR YOURSELF. REFER SERVICING TO QUALIFIED PERSONNEL.

WARNING:

TO REDUCE THE RISK OF FIRE, ELECTRIC SHOCK OR PRODUCT DAMAGE, DO NOT EXPOSE THIS APPLIANCE TO RAIN, SPLASHING, DRIPPING OR MOISTURE.

CAUTION:

TO PREVENT ELECTRIC SHOCK MATCH WIDE BLADE OF PLUG TO WIDE SLOT, FULLY INSERT.

FCC NOTE: (U.S.A. Only)

This equipment has been tested and found to comply with the limits for a Class B digital device, pursuant to Part 15 of the FCC Rules. These limits are designed to provide reasonable protection against harmful interference in a residential installation. This equipment generates, uses and can radiate radio frequency energy and, if not installed and used in accordance with the instructions, may cause harmful interference to radio communications. However, there is no guarantee that interference will not occur in a particular installation. If this equipment does cause harmful interference to radio or television reception, which can be determined by turning the equipment off and on, the user is encouraged to try to correct the interference by one or more of the following measures:

- Reorient or relocate the receiving antenna.
- Increase the separation between the equipment and receiver.
- Connect the equipment into an outlet on a circuit different from that to which the receiver is connected.
- Consult the dealer or an experienced radio/TV technician for help.

FCC Caution: To assure continued compliance, follow the attached installation instructions and use only shielded cables when connecting to other devices. Also, any changes or modifications not expressly approved by the party responsible for compliance could void the user's authority to operate this equipment.

CAUTION	- LASER RADIATION WHEN OPEN. DO NOT STARE INTO BEAM.
ATTENTION	- RAYONNEMENT LASER EN CAS D'OUVERTURE. NE PAS REGARDER DANS LE FAISCEAU.
VORSICHT	- LASERSTRAHLUNG, WENN ABDECKUNG GEOFFNET. NICHT IN DEN STRAHL BLICKEN.
ADVARSEL	- LASERSTRÅLING VED ÅBNING. SE IKKE IND I STRÅLEN.
ADVARSEL	- LASERSTRÅLING NÅR DEKSEL ÅPNES. STIRR IKKE INN I STRÅLEN.
VARNING	- LASERSTRÅLNING NÅR DENNA DEL ÅR ÖPPNAD. STIRRA EJ IN I STRÅLEN.
VARO!	- AVATTAESSA OLET ALTIINNA LASERSÄTELYLLE. ÄLÄ TULJOTA SÄTEESEEN.
注意	- 当打开这里会出现激光, 请不要直视激光。
注意	- ここを開くとレーザー光が出ます。 レーザー光をのぞき込まないでください。

(Inside of player)



CAUTION

RISK OF ELECTRIC SHOCK
DO NOT OPEN



CAUTION: TO REDUCE THE RISK OF ELECTRIC SHOCK, DO NOT REMOVE SCREWS. NO USER-SERVICEABLE PARTS INSIDE. REFER SERVICING TO QUALIFIED SERVICE PERSONNEL.



The lightning flash with arrowhead symbol, within an equilateral triangle, is intended to alert the user to the presence of uninsulated "dangerous voltage" within the product's enclosure that may be of sufficient magnitude to constitute a risk of electric shock to persons.



The exclamation point within an equilateral triangle is intended to alert the user to the presence of important operating and maintenance (servicing) instructions in the literature accompanying the appliance.

Getting started

PRECAUTIONS

Before using this unit please read these operating instructions carefully. Take special care to follow the warnings indicated on the unit itself as well as the safety suggestions listed below. Afterwards keep them handy for future reference.

Safety

- 1. Power Source**—The unit should be connected to a power supply only of the type described in the operating instructions or as marked on the unit. If you are not sure of the type of power supply to your home, consult your appliance dealer or local power company.
- 2. Polarization**—If the unit is equipped with a polarized AC power plug (a plug having one blade wider than the other), that plug will fit into the AC outlet only one way. This is a safety feature. If you are unable to insert the plug fully into the outlet, try reversing the plug. If the plug should still fail to fit, contact your electrician to replace your obsolete outlet. Do not defeat the safety purpose of the polarized plug.
- 3. Power Cord Protection**—AC power supply cords should be routed so that they are not likely to be walked on or pinched by items placed upon or against them. Never take hold of the plug or cord if your hand is wet, and always grasp the plug body when connecting or disconnecting it.
- 4. Overloading**—Do not overload wall outlets and extension cords as this can result in a risk of fire or electric shock.
- 5. Nonuse Periods**—When the unit is not being used, turn the power off. When left unused for a long time, the unit should be unplugged from the household AC outlet.
- 6. Attachments**—Do not use attachments not recommended by the unit manufacturer as they may cause hazards.

Installation

Environment

- 1. Water and Moisture**—Do not use this unit near water—for example, near a bathtub, washbowl, swimming pool, or the like. Damp basements should also be avoided.
- 2. Condensation**—Moisture may form on the lens in the following conditions...
 - immediately after a heater has been turned on.
 - in a steamy or very humid room.
 - when the unit is suddenly moved from a cold environment to a warm one.If moisture forms inside this unit, it may not operate properly. To correct this problem, turn on the power and wait about one hour for the moisture to evaporate.
- 3. Heat**—The unit should be situated away from heat sources such as radiators and the like. It also should not be placed in temperatures less than 5°C (41°F) or greater than 35°C (95°F).

Placement

- 1. Ventilation**—The unit should be situated so that its location or position does not interfere with its proper ventilation. Allow 10 cm (4") clearance from the rear of the unit.
- 2. Foreign Material**—Care should be taken so that objects do not fall into and liquids are not spilled into the unit. Do not subject this unit to excessive smoke, dust, mechanical vibration, or shock.
- 3. Carts and Stands**—The unit should be used only with a cart or stand that is recommended by the manufacturer. The unit and cart combination should be moved with care. Quick stops, excessive force, and uneven surfaces may cause the unit and cart combination to overturn. 
- 4. Mounting**—Any mounting of the appliance should follow the manufacturer's instructions, and should use a mounting accessory recommended by the manufacturer.

Maintenance

Disconnect this unit from the AC outlet before cleaning. Clean the cabinet, panel and controls with a soft cloth lightly moistened with a mild detergent solution. Do not use any type of abrasive pad, scouring powder or solvent such as alcohol or benzene.

Service

- 1. Damage Requiring Service**—The unit should be serviced by qualified service personnel when:
 - (a) The AC power supply cord or the plug has been damaged; or
 - (b) Objects have fallen or liquid has been spilled into the unit; or
 - (c) The unit has been exposed to water; or
 - (d) The unit does not appear to operate normally or exhibits a marked change in performance; or
 - (e) The unit has been dropped, or the enclosure damaged.
- 2. Servicing**—The user should not attempt to service the unit beyond that described in the operating instructions. All other servicing should be referred to an authorized service personnel.

For the address of an authorized servicer:
In the U.S.A., call 1-800-211-7262,
e-mail consumerproducts@panasonic.com,
or visit www.panasonic.com
In Canada, call 1-800-561-5505
or visit www.panasonic.ca
- 3. Replacement parts**—When parts need replacing, ensure the servicer uses parts specified by the manufacturer or parts that have the same characteristics as the original parts. Unauthorized substitutes may result in fire, electric shock, or other hazards.
- 4. Safety check**—After repairs or service, ask the servicer to perform safety checks to confirm that the unit is in proper working condition.

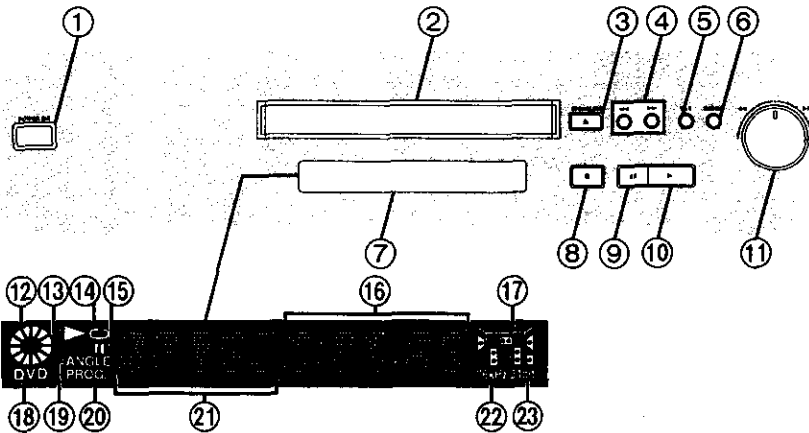

Buttons such as 1 function the same as the controls on the player.

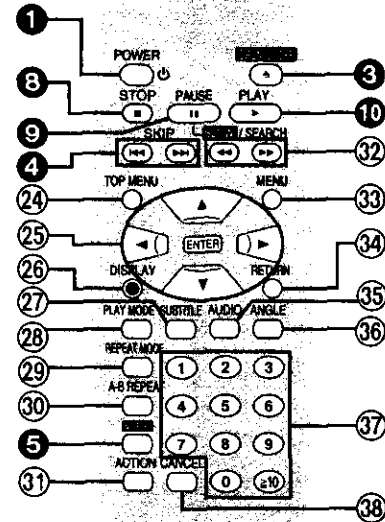

Getting started

Player

	Page
1 Standby/on switch (POWER $\text{\textcircled{I}}$)	11
Press to switch the unit from on to standby mode or vice versa. In standby mode, the unit is still consuming a small amount of power.	
2 Disc tray	11
3 Disc tray open/close button (\blacktriangle OPEN/CLOSE)	11
4 Skip buttons (\blacktriangleleft , \blacktriangleright)	11, 13
5 Virtual Surround Sound button/indicator (V.S.S.)	22
6 Cinema button/indicator (CINEMA)	19
7 FL display	
8 Stop button (\blacksquare)	12
9 Pause button ($\text{\textcircled{II}}$)	13
10 Play button (\blacktriangleright)	11
11 Shuttle dial (\blacktriangleleft , \blacktriangleright)	14
12	
Rotates during play.	
Rotates fast clockwise or counterclockwise during rapid advance (rapid reverse).	
Rotates slowly clockwise or counterclockwise during slow-motion play. DVD VCD	
Illuminates in the stop mode.	
13	
Illuminates during playback.	
Flashes when the RESUME function is ON.	
14	
Illuminates during repeat play.	
15	
Illuminates in the still picture (pause) mode.	
16	
Elapsed playing time from the start of the title/track during play	
17	
Audio channel information recorded in the disc being played back (e.g. 2ch or 5.1ch)	

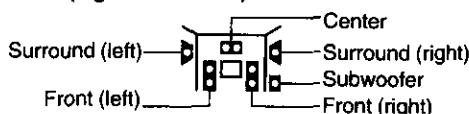





- 18 A DVD is loaded.
- 19 It is possible to change the angle. **DVD**
- 20 Illuminates during program play. **VCD** **CD**
- 21 Title/chapter number **DVD**
Track number **VCD** **CD**
- 22 Linear PCM of 96 kHz sampling is being played.
- 23 Linear PCM of 24 bit is being played.

Remote control

	Page
24 Top menu button (TOP MENU)	11, 15
25 Cursor buttons (\blacktriangle , \blacktriangledown , \blacktriangleleft , \blacktriangleright)/Enter button (ENTER)	11
26 Display button (DISPLAY)	23
27 Subtitle button (SUBTITLE)	17
28 Play mode button (PLAY MODE)	20
29 Repeat mode button (REPEAT MODE)	18
30 A-B repeat button (A-B REPEAT)	18
31 Action button (ACTION)	26
32 Slow/Search buttons (\blacktriangleleft , \blacktriangleright SLOW/SEARCH)	14
33 Menu button (MENU)	11, 15
34 Return button (RETURN)	11
35 Audio button (AUDIO)	16
36 Angle button (ANGLE)	17
37 Numeric buttons (1-9, 0, $\text{\textcircled{=}}$ 10)	11
•To select a 2-digit number	
Example: To select track 23	
Press [$\text{\textcircled{=}}$ 10], then [2] and [3].	
38 Cancel button (CANCEL)	20

Disc information

 Discs supported by this unit	 Discs not supported by this unit
DVD-Video  8 cm (3") disc/ 12 cm (5") disc	<ul style="list-style-type: none"> • Do not try to play Photo CD or CD-R. (Data on the disc may be damaged.) • DVD with region number other than "1" or "ALL" • PAL discs • DVD-ROM • DVD-R • DVD-RW • CVD • CDV etc. <ul style="list-style-type: none"> • CD-G • CD-RW • DVD-RAM • SVCD • SACD <ul style="list-style-type: none"> • Divx Video Disc • DVD-Audio • DVD+RW • CD-ROM • VSD
Video CD  8 cm (3") disc/ 12 cm (5") disc	
Audio CD  8 cm (3") disc/ 12 cm (5") disc	

For the purpose of these operating instructions, "DVD" stands for DVD-Video and "CD" stands for Audio CD.

■ Region number supported by this unit

Region numbers are allocated to DVD players and software according to where they are sold.

- The region number of this unit is "1".
- The unit will play DVDs marked with labels containing the region number "1" or "ALL".

Example:



■ Playing DVDs and Video CDs

The producer of the material can control how these discs are played. This means that you may not be able to control play of a disc with some operations described in these operating instructions. Read the disc's instructions carefully.

- Example:**
- "⊙" appears when you press the skip buttons to move to the next section.
 - Resume, repeat play, and markers may not work during play of interactive DVDs and menu play of Video CDs with playback control.
 - After showing the Karaoke menu, tracks are played successively without returning to the menu (Video CD with playback control).

■ Terms used in these operating instructions

• Title/Chapter **[DVD]**

DVDs are divided up into large sections, titles, and smaller sections, chapters. The numbers allocated to these sections are called title numbers and chapter numbers.

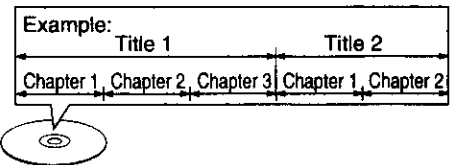

• Track **[VCD CD]**

Video CDs and CDs are divided up into sections called tracks, and the numbers allocated to these sections are called track numbers.

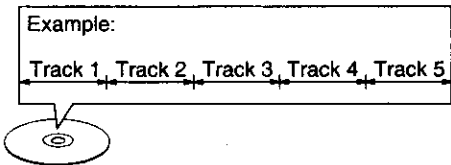

• Playback control **[VCD]**

If a Video CD has "playback control" written on it or its jacket, it means that particular scenes or information can be selected for viewing interactively with the TV monitor using the menu screen. This unit can play Video CDs with playback control. Using menus to control play of a Video CD is called "menu play" in these operating instructions.

Display during menu play of a Video CD with playback control

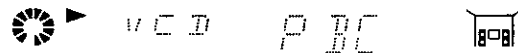

• Interactive DVD **[DVD]**

An interactive DVD is DVD software which includes multiple angles, multiple plot endings, etc. The elapsed play time of some of these DVDs is not shown.

Display during play of an interactive DVD

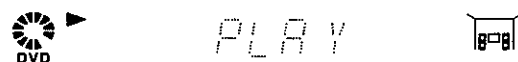

Disc handling

Do not use irregularly shaped discs, such as heart-shaped. (These can damage the unit.)

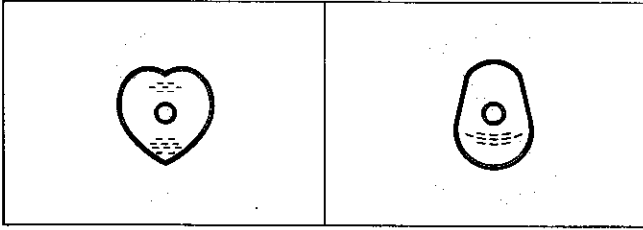

■ How to hold a disc

Do not touch the recorded surface.

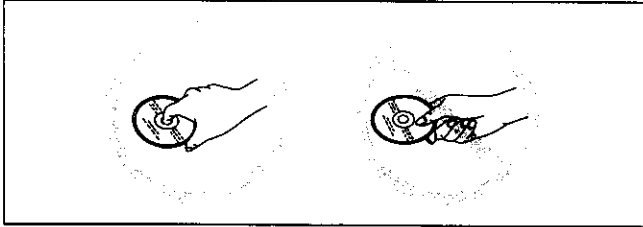

■ If the surface is dirty

Wipe it with a damp cloth and then wipe dry.

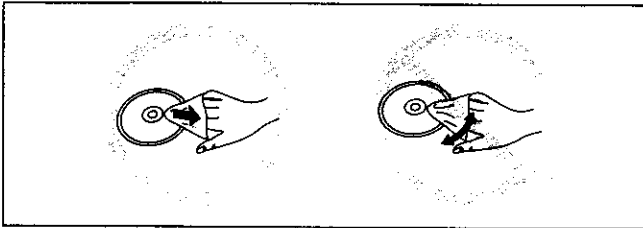

■ If the disc is brought from a cold to a warm environment, moisture may form on the disc

Wipe with a soft, dry, lint-free cloth before using the disc.

■ Handling precautions

- Do not write on the label side with a ball-point pen or other writing instrument.
- Do not use record cleaning sprays, benzine, thinner, static electricity prevention liquids or any other solvent.
- Do not attach labels or stickers to discs. (Do not use discs with exposed adhesive from tape or left over peeled-off stickers.)
- Do not use scratch-proof protectors or covers other than those specified for use with this unit.

■ Do not place or store discs in the following places

- Locations exposed to direct sunlight
- Humid or dusty locations
- Locations directly exposed to a heat vent or heating appliance

Maintenance

To clean this unit, wipe with a soft, dry cloth.

If the surfaces are extremely dirty, use a soft cloth dipped in a soap-and-water solution or a weak detergent solution.

- Never use alcohol, paint thinner or benzine to clean this unit.
- Before using chemically treated cloth, read the instructions that came with the cloth carefully.

Remote control preparations

Battery installation

Use of batteries

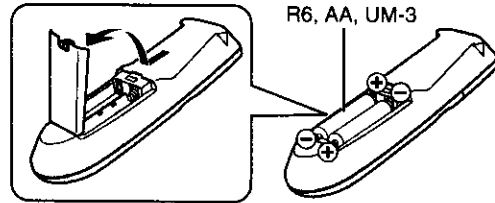

- Align the poles (+ and -) properly when inserting the batteries.
- Do not mix old and new batteries or different types of batteries.
- Do not recharge ordinary dry cell batteries.
- Do not heat or disassemble the batteries. Do not allow them to contact flame or water.
- Remove the batteries if the unit is not to be used for a long time.
- Do not keep together with metallic objects such as necklaces.
- Do not use rechargeable type batteries.
- Do not use batteries if the covering has been peeled off.

Mishandling of batteries can cause electrolyte leakage which can damage items the fluid contacts and may cause a fire.

If electrolyte leaks from the batteries, consult your dealer.

Wash thoroughly with water if electrolyte comes in contact with any part of your body.

Correct method of use

Operation notes

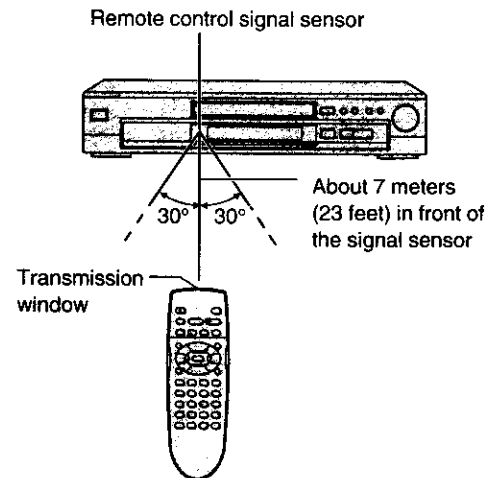

- Do not place obstacles between the remote control signal sensor and remote control unit.
- Do not expose the remote control signal sensor to direct sunlight or to the bright light of a fluorescent light.
- Take care to keep the remote control signal sensor and end of the remote control unit free from the dust.
- If this system is installed in a rack with glass doors, the glass doors' thickness or color might make it necessary to use the remote control a shorter distance from the system.

To prevent damage

- Never place heavy items on top of the unit.
- Do not disassemble or reconstruct the unit.
- Do not spill water or other liquids into the unit.

Connection to a television

- Ensure that this unit and other equipment to be connected are switched to the standby mode or off and disconnect the AC power supply cord before commencing connection.
- Read through the instructions before connecting other equipment.
- Ensure that you observe the color coding when connecting audio and video cables.
- See page 32 for information about how to upgrade your system with other audio/visual equipment.

Note

- Peripheral equipment and optional cables sold separately unless otherwise indicated.
- TV volume may be lower when playing DVDs than during television broadcasts. Turn the volume up while playing DVDs and reduce it to the previous level **before** switching the source back to television to avoid sudden changes in volume.
- When you have finished connection, select the appropriate screen type at the initial setting "6 TV Aspect" according to your television (4:3/16:9) (→ page 10). No changes are needed if you connect the unit to a conventional television (4:3).

Conserving power

- The unit consumes approx. 2.0 W even when it is turned off with [POWER ⏻/I]. To save power when the unit is not to be used for a long time, unplug it from the household AC outlet.

Connect Your Unit Directly To Your Television.

If the unit is connected to the television through a video cassette recorder, the picture may not be played correctly due to the copy guard. So we strongly recommend you do not connect the unit to your video cassette recorder when setting up your home entertainment system.

- Connect to the television section if you connect the unit to a combined television-video player.

Do not place the unit on amplifiers or other equipment which may become hot.

The heat can damage the unit.

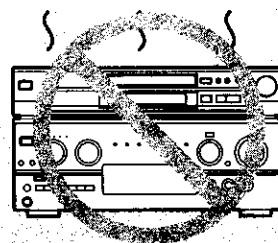

Connecting to a television with video input terminal or S video input terminal

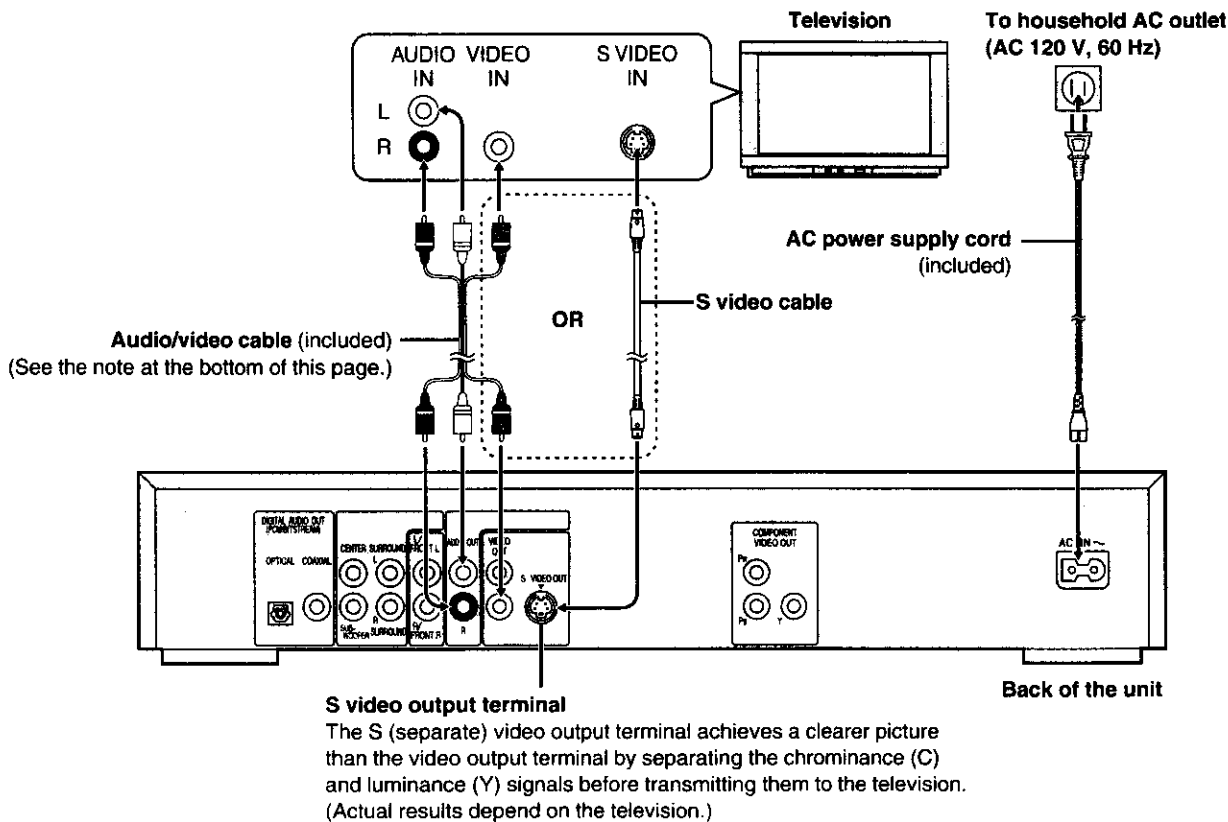

Note

- If your television is monaural, use a stereo-monaural audio cable instead of the supplied audio/video cable. The video part of the cable (yellow) can still be used if required.

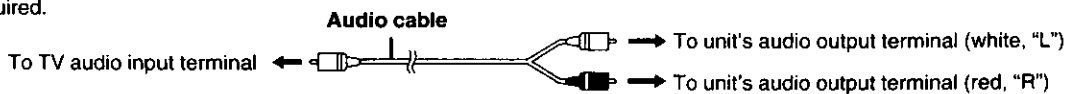

Connecting to a television with component video input terminals

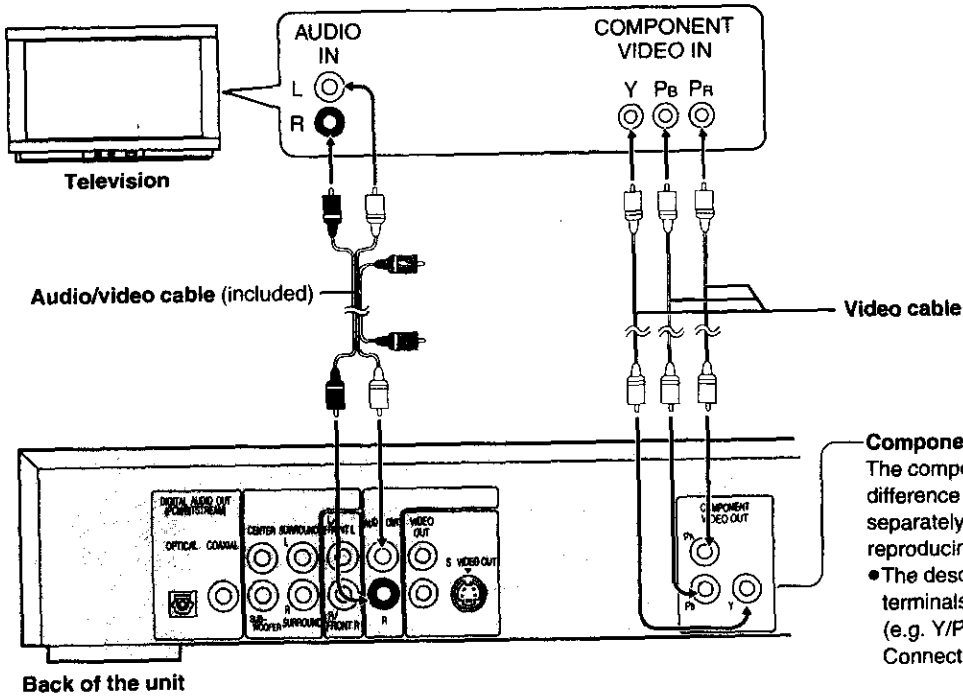

Component video output terminals (Y/P_B/P_R)

The component video output terminals output the color difference signals (P_B/P_R) and luminance signal (Y) separately in order to achieve high fidelity in reproducing colors.

- The description of the component video input terminals depends on the television or monitor (e.g. Y/P_B/P_R, Y/B-Y/R-Y, Y/C_B/C_R and so on). Connect to terminals of the same color.

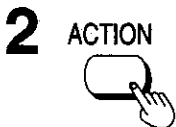
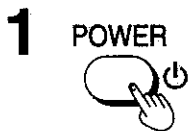
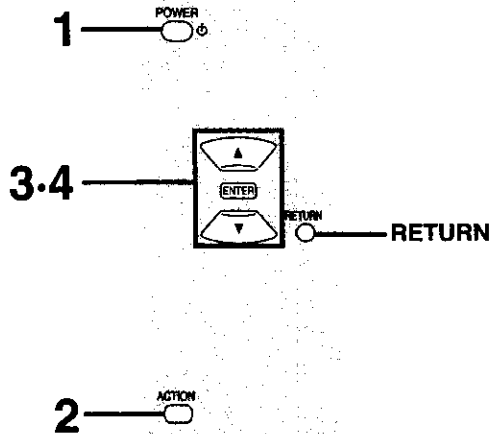

1	Disk Languages	
2	Ratings	Level 8
3	Menu Language	English
4	On-Screen Messages	
5	FL Display	Bright
6	TV Aspect	4:3
7	Digital Audio Output	
8	Speaker Setting	2-channel
9	Other Settings	

Press RETURN to exit

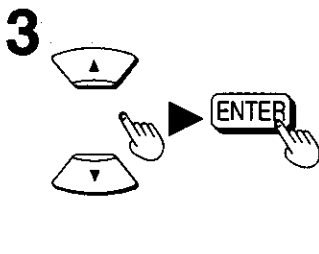

Select your TV aspect		
1	4:3	<input type="checkbox"/>
2	16:9	<input type="checkbox"/>

Press RETURN to exit

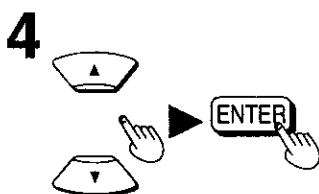

Connection to a television

Before enjoying DVD/Video CD/CD

The menu language for this unit has been set to English, but you can change the language to French or Spanish (⇒ "3 Menu Language", page 29). English has been used in the examples shown.

Selecting TV screen type

Select the TV aspect, conventional size screen (4:3) or widescreen (16:9), according to your television.

Preparations

- Ensure connections to your television and audio equipment are correct.
- Turn on your television and other equipment.
- Switch the video input mode on the television to suit the type of connection you have made (e.g., VCR 2).

- 1 Press [POWER] to switch on the power.**
- 2 Press [ACTION] in the stop mode.**
The initial settings screen is displayed.
- 3 Press the cursor buttons [▲, ▼] to select "6 TV Aspect" and press [ENTER].**
- 4 Press the cursor buttons [▲, ▼] to select a TV aspect and press [ENTER].**

- 1 4:3 (Factory preset)**
Select when a conventional television is connected.
- 2 16:9**
Select when a widescreen television is connected.

Setting is finished and the initial settings screen in step 2 is displayed.

To cancel during setup operation

Press [RETURN]. (The previous screen is displayed.)

To exit the initial settings screen

Press [ACTION] or [RETURN].

For your reference

- For further details on the images which appear on the TV screen, see page 31.

Basic play

Preparations

- Ensure connections to your television and audio equipment are correct.
- Turn on your television and other equipment.
- Switch the video input mode on the television to suit the type of connection you have made (e.g., VCR 2).

- 1 Press [POWER \odot /I] to switch on the power.**
- 2 Press [\blacktriangle OPEN/CLOSE] to open the disc tray.**
- 3 Place the disc on the disc tray.**
 - Insert inside the guides.
 - Do not load more than one disc.
- 4 Press [\blacktriangleright].**
The disc tray is automatically closed and play begins.

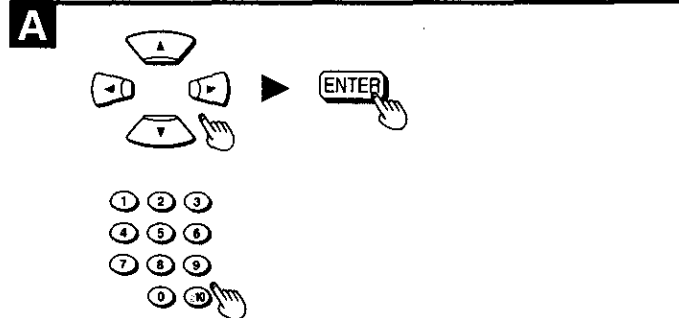
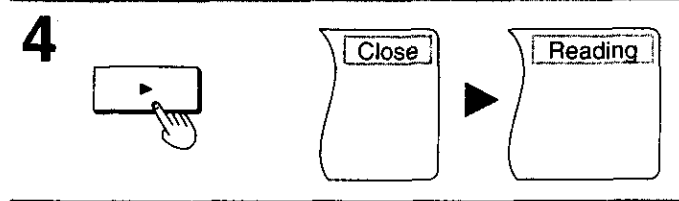
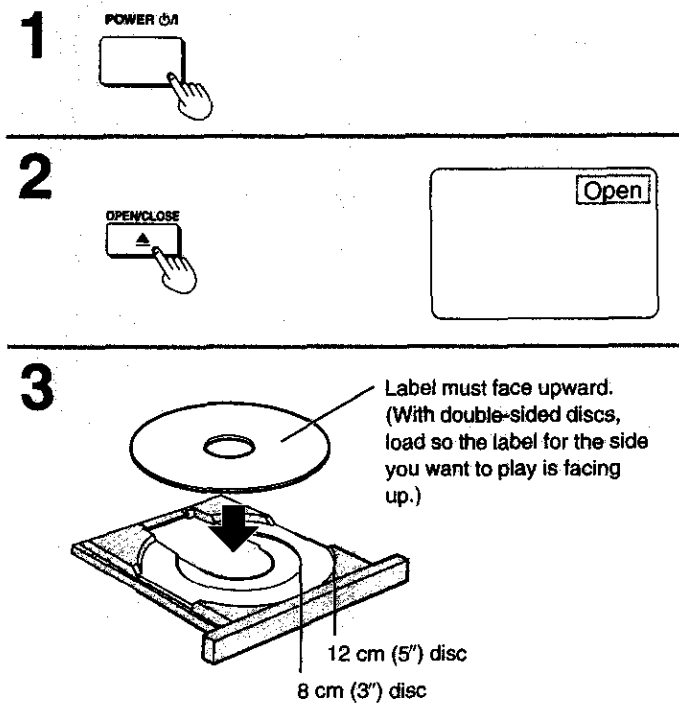
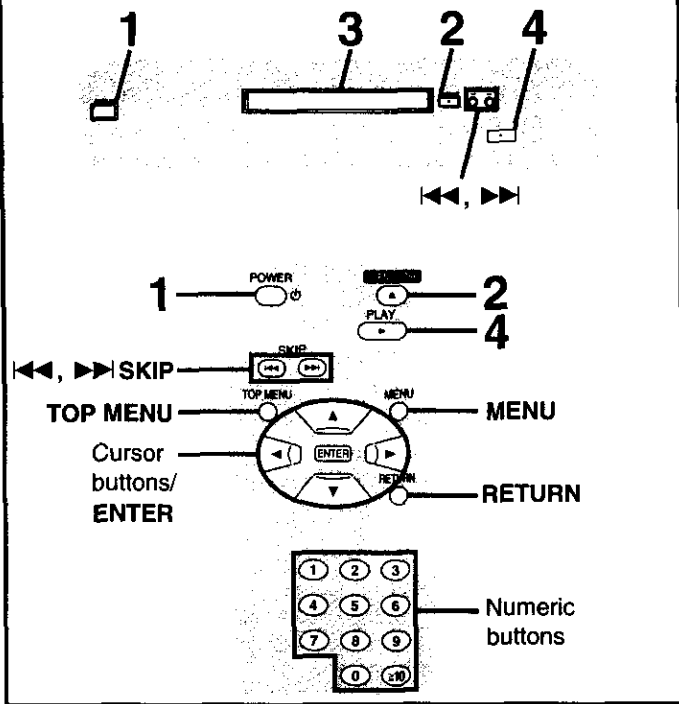

A When a menu screen appears on the TV monitor

DVD VCD
Press the cursor buttons [\blacktriangle , \blacktriangledown , \blacktriangleleft , \blacktriangleright] and press [ENTER], or press the numeric buttons, to select the item.

Play of the selected item now begins.
• The cursor buttons are not effective for selecting items on Video CDs.

Other buttons used to operate menus
Read the disc's instructions for further details about operation.

- [$\blacktriangleright\blacktriangleright$ SKIP]: Shows the next menu.
- [$\blacktriangleleft\blacktriangleleft$ SKIP]: Shows the previous menu.
- [RETURN]: Shows the menu screen.
- [TOP MENU]: Shows the first menu screen. **DVD**
- [MENU]: Shows the menu screen. **DVD**

Note
• "NO PLAY" is displayed on the FL display if you load the following kinds of discs that cannot be played:
• DVD for which play is prohibited by the initial settings "2 Ratings" (⇒ page 28).
• DVD with a region number other than "1" or "ALL" (⇒ page 6).
• If "⊙" appears on the TV monitor when a button is pressed, the operation is prohibited by the unit or disc.

Basic operations

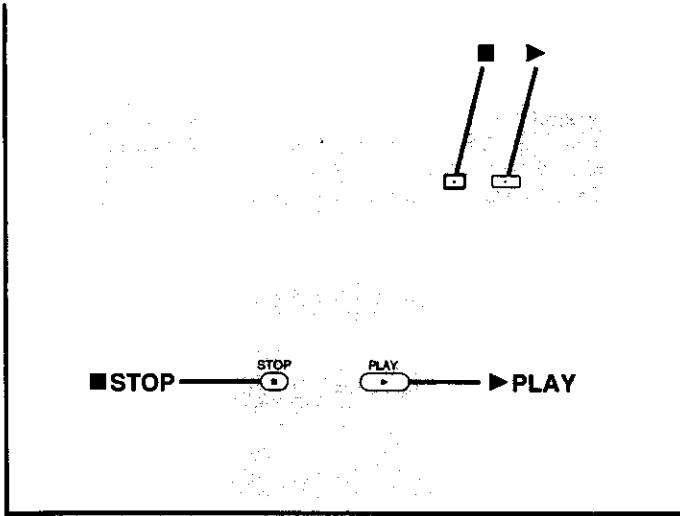

A



B

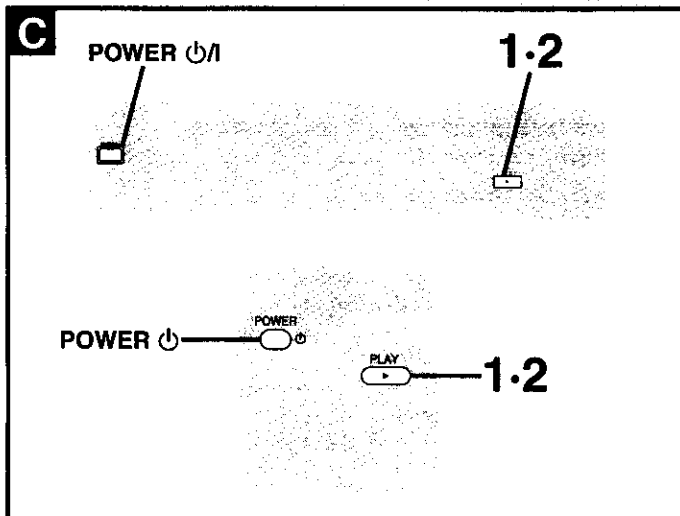
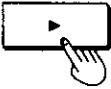

1

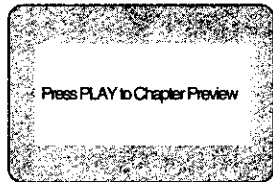
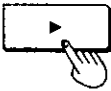

2

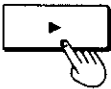

Basic play

A Stopping play

Press [■] during play.

- The unit records the point where [■] was pressed during play. ("▷" flashes on the unit's FL display.)

B To resume play from where you stopped (RESUME function)

Press [▶] while "▷" is flashing on the FL display.

Play will resume from the point where [■] was pressed.

To clear the RESUME function

Press [■] again or open the disc tray while "▷" is flashing on the FL display.

Note

- The RESUME function works only with titles for which the elapsed playing time appears on the unit's FL display during play.
- This feature remains active if the unit is switched to the standby mode and then turned back ON.

C Chapter preview function

DVD

This function plays the first few seconds of each chapter from the beginning of the title up to the point where operation was stopped. This makes it possible to review previous chapters.

1. Press [▶] while "▷" is flashing on the FL display. (The message illustrated is briefly displayed.)
2. Press [▶] again while the message is displayed on the screen.

Normal play will commence from the point where operation was stopped.

Note

- Canceling the RESUME function will also clear the chapter preview function.
- The chapter preview function may not work with some DVDs.

■ After operation

When the unit is not in use, remove the disc and press [POWER (⏻)] to switch the unit to the standby mode.

The unit is automatically switched to the standby mode after approx. 30 minutes have elapsed in the stop mode.

(Auto power-off function)

Note

- The disc continues to rotate while the menu is displayed even after the unit has finished playing a particular item. Stop the unit when you finish viewing to preserve the unit's motor and your television screen.

Other methods of play

Features on the next few pages are accessed primarily by using the remote control.

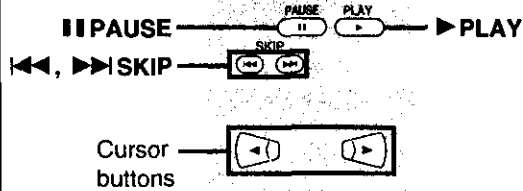

A Still picture (Pause)

Press [|| PAUSE] during play.

To return to normal play
Press [▶ PLAY].

B Skipping chapters or tracks

Press [◀◀, ▶▶ SKIP] during play or while paused.

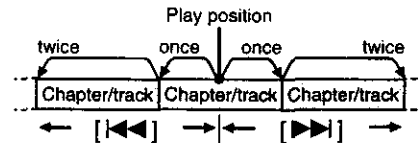

For your reference

- When [◀◀, ▶▶ SKIP] is pressed during menu play of Video CDs with playback control, a menu screen may be recalled.

C Frame advance (Frame reverse)

DVD VCD

Press the cursor buttons [◀, ▶] while paused.

- The disc is advanced (reversed) by one frame each time the cursor buttons [◀, ▶] are pressed.
- When the cursor buttons [◀, ▶] are held, consecutive frame advance (reverse) is activated.

To return to normal play
Press [▶ PLAY].

Note

- For Video CDs, frame reverse is not an available function.

For your reference

- Pressing [|| PAUSE] also activates frame advance.
- Whether the pictures are advanced by a "Frame" or "Field" is automatic, but you can change the initial settings to choose how the picture is advanced (⇒ "1 Still Mode" in "9 Other Settings", page 30).

A

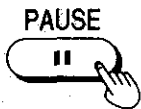

B

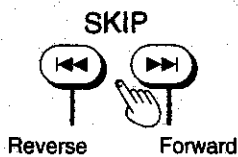

C

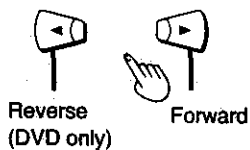

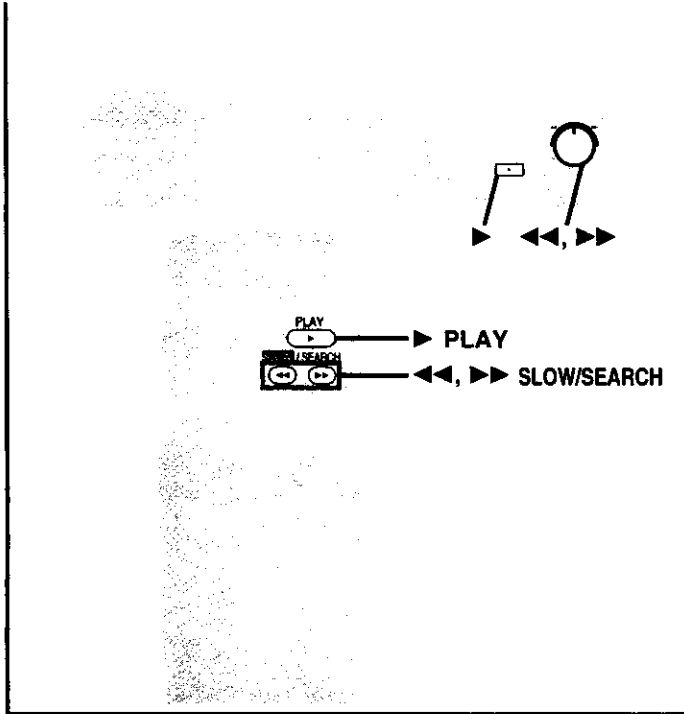

A

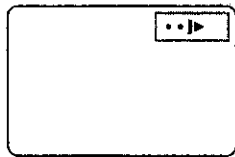

B

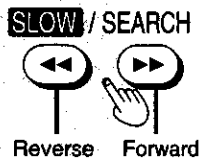

Other methods of play

A Slow-motion play

DVD VCD

Press [\ll , \gg SLOW/SEARCH] while paused (→ page 13).

- Each press increases the speed of slow-motion.

On the main unit

Turn the shuttle dial [\ll , \gg] while paused (→ page 13).

- The speed of slow-motion increases the more you turn the shuttle dial.
- The picture stills again when you release the shuttle dial.

- There are 5 speeds of slow-motion.

To return to normal play

Press [\triangleright PLAY].

Note

- For Video CDs, slow-motion play in reverse is not an available function.

For your reference

- When [\ll , \gg SLOW/SEARCH] or the shuttle dial [\ll , \gg] on the main unit is used during menu play of Video CDs with playback control, a menu screen may be recalled.

B Rapid advance (Rapid reverse)

Press [\ll , \gg SLOW/SEARCH] during play.

- Each press increases the speed of the search.

On the main unit

Turn the shuttle dial [\ll , \gg] during play.

- The speed of the search increases the more you turn the shuttle dial.
- Play starts again when you release the shuttle dial.

- There are 5 speeds of advance (reverse).

To return to normal play

Press [\triangleright PLAY].

For your reference

- When [\ll , \gg SLOW/SEARCH] or the shuttle dial [\ll , \gg] on the main unit is used during menu play of Video CDs with playback control, a menu screen may be recalled.
- For DVDs and Video CDs, audio will be heard during searching (forward direction only) at the initial search speed (To turn audio off, → "2 Audio during Search" in "9 Other Settings", page 30).

Other methods of play

A Starting play from a selected title or track

Preparation (Video CDs with playback control only)

Press [■ STOP] to cancel menu play.

("PBC" will be cleared from the unit's FL display.)

While stopped

Press the numeric buttons.

To select a 2-digit number

Example: To select track 23

Press [≧10], then [2] and [3].

Play starts from the selected title/track.

Note

- The numeric buttons also work during play if the disc is a Karaoke DVD, Video CD, or CD.
- This may not work with some discs.

■ To return to menu play of a Video CD with playback control

Press [■ STOP] to stop play, press [MENU], and press the numeric buttons to select an item.

"PBC" lights on the unit's FL display.

B Using menus to play

DVD

By calling up menus during play, you can start play from a specific title or chapter, or change the soundtrack and subtitle languages.

1 Press [TOP MENU] or [MENU] during play to display the menu.

- Press again to return to what you were watching.

2 Press the cursor buttons [▲, ▼, ◀, ▶] to select an item and press [ENTER].

The selected item is confirmed.

- Repeat if other menus are shown.

DVDs can have several menus. The menu displayed when you press [TOP MENU] may be different from the menu displayed when you press [MENU]. **C**

For your reference

- Menu content depends on the disc. These operating instructions describe basic steps.
- Both buttons take you to the same menu if the disc has only one menu.

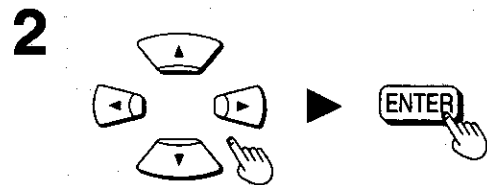
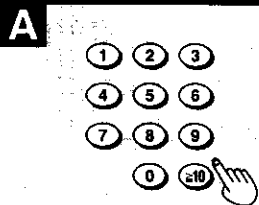
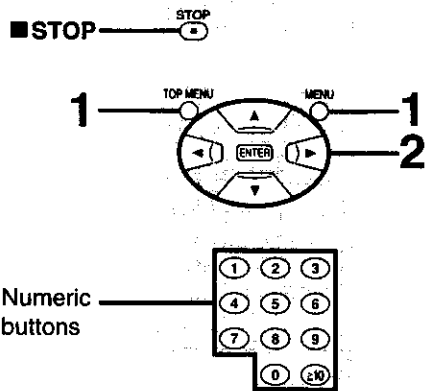

C Example: If you press the buttons while you are playing title 2

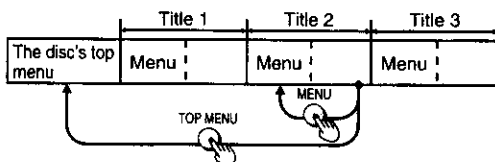

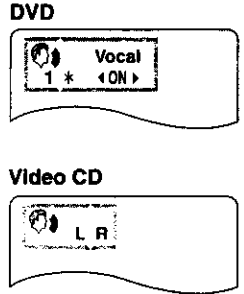
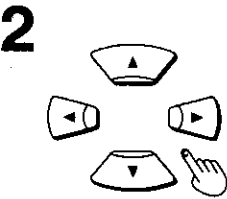
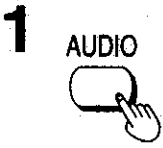
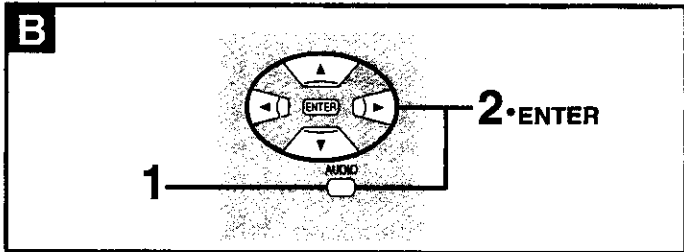
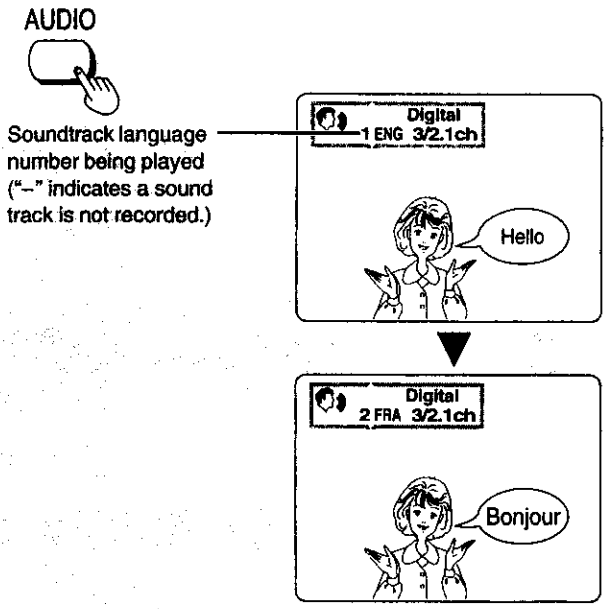
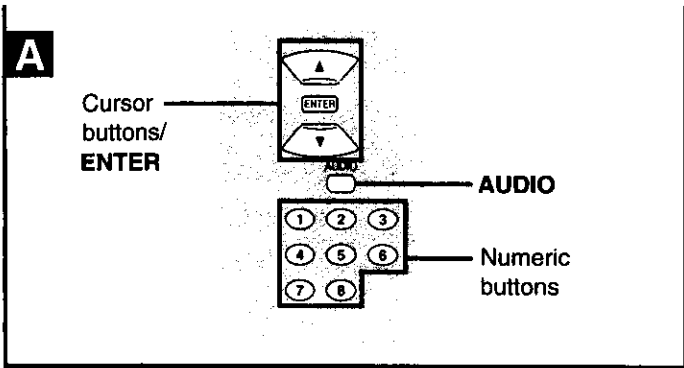

Advanced operations

A Changing soundtrack language

DVD

Some DVDs have more than one soundtrack language recorded on them, and you can change soundtrack language during play.

Press [AUDIO] during play to display the current language number.

The number changes each time you press the button.

- You can also use the cursor buttons [▲, ▼] or the numeric buttons to change the language number.

To clear the display

Press [ENTER].

For your reference

- You can only select languages or sound formats if they have been recorded on the disc you are playing.
- If the RESUME function (⇒ page 12) is canceled or if you stop play of an interactive DVD, the soundtrack languages revert to the initial settings (⇒ page 27).
- Some discs allow changes to soundtrack languages only by using the disc's menus.

B Switching vocals ON or OFF for Karaoke discs

DVD VCD

1. Press [AUDIO] during play.
2. Press the cursor buttons [▲, ▼, ◀, ▶] or press [AUDIO] to change the setting.

DVD Karaoke [◀, ▶]

- | | |
|-----------------|---------------------|
| • Solo | • Duet |
| ----: Vocal OFF | ----: Vocal OFF |
| ON: Vocal ON | 1+2: Vocal 1, 2 ON |
| | V1: Vocal 1 only ON |
| | V2: Vocal 2 only ON |

- Choose "----" for Karaoke.
- Choose "V1" or "V2" to duet with the unit.

Video CD ([▲, ▼] or [AUDIO])

- LR: Vocals (Vocals seem to come from the right)
- L: No Vocals
- R: Vocals (Vocals seem to come from both left and right)
- Choose "L" for Karaoke.

To clear the display

Press [ENTER].

For your reference

- Karaoke discs may show a menu after each track. Some will have a menu that allows you to play all the tracks.
- Some discs require different operations from those described. Read the disc's instructions for details.

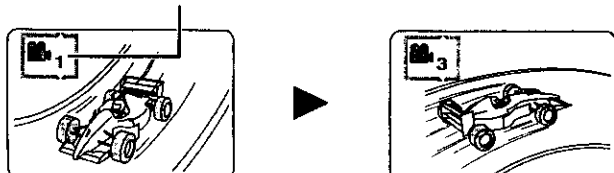
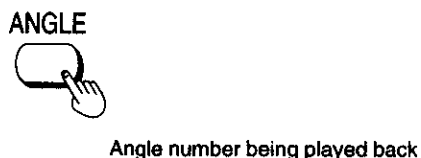
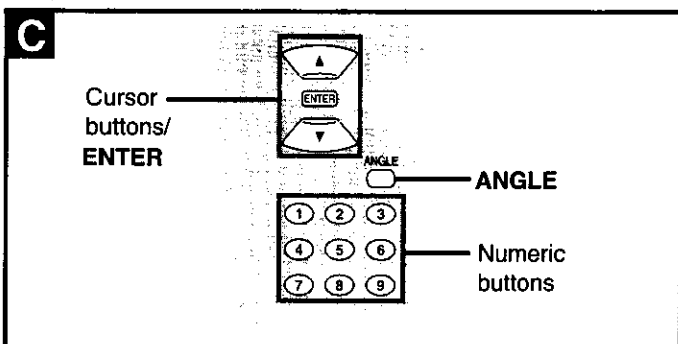
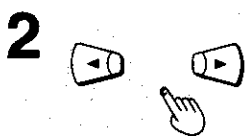
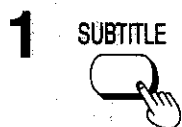
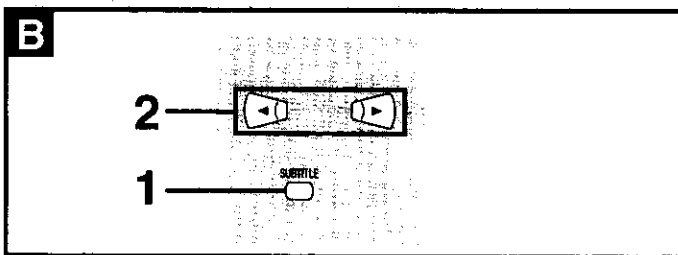
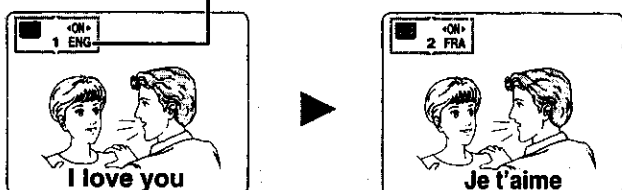
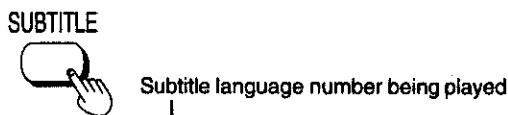
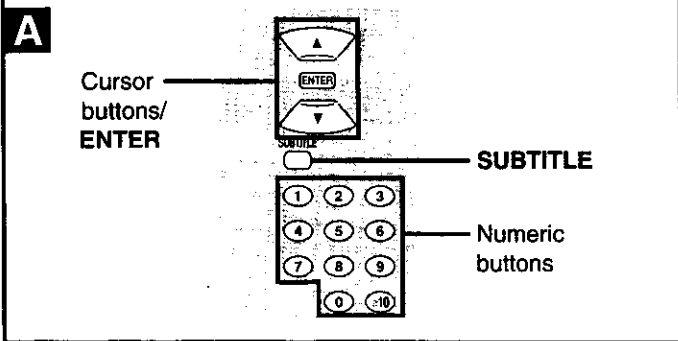

A Changing subtitle language

DVD

Some DVDs have more than one subtitle language recorded on them, and you can change subtitle language during play.

Press [SUBTITLE] during play to display the current language number.

The number changes each time you press the button.

- You can also use the cursor buttons [▲, ▼] or the numeric buttons to change the language number.
- “-” is displayed in circumstances such as when subtitles are not recorded on the disc.

To clear the display

Press [ENTER].

B To clear/display the subtitles

1. Press [SUBTITLE].
2. Press the cursor buttons [◀, ▶] to select “ON” or “OFF”.

Note

- In some cases, the subtitle language is not changed to the selected one immediately.
- When a disc supporting closed captions is played, the subtitles and closed captions may overlap each other on the TV monitor. In this case, turn the subtitles off.

For your reference

- You can only select languages if they have been recorded on the disc you are playing.
- If the RESUME function (⇒ page 12) is canceled or if you stop play of an interactive DVD, the subtitle languages revert to the initial settings (⇒ page 27).
- Some discs allow changes to subtitle languages only by using the disc's menus.

C Viewing from another angle

DVD

Some DVDs allow you to view the same scene from different angles. “ANGLE” lights on the FL display to indicate that the feature is available.

Press [ANGLE] during play to display the current angle number.

The number changes each time you press the button.

- You can also use the cursor buttons [▲, ▼] or the numeric buttons to change the angle.

To clear the display

Press [ENTER].

For your reference

- You can only select angles if they have been recorded on the disc you are playing.
- Some discs allow you to set angles before multi-angle scenes are played.
- Some discs allow changes to angles only by using the disc's menus.

Advanced operations

A Repeat play

Press [REPEAT MODE] during play.

Each time you press the button, the TV monitor changes as illustrated and the disc will repeat a chapter or title (DVD) or a track (Video CD/CD). Repeat play starts when the display changes.

•DVD

- (a) Normal play
- (b) Repeat of chapter being played
- (c) Repeat of title being played
- (d) Cancel repeat mode (Normal play)

•Video CD/CD

- (e) Normal play
- (f) Repeat of track being played
- (g) Repeat of entire disc contents
- (h) Cancel repeat mode (Normal play)

To return to normal play

Press [REPEAT MODE] until "OFF" is displayed.

Note

- Repeat play may not work as desired with some DVDs.
- Repeat play does not work with interactive DVDs or during menu play of a Video CD with playback control.
- There is no mode for repeating the whole DVD.

B To enjoy program repeat play

VCD CD

If you press [REPEAT MODE] during program play (⇒ page 20), the display changes as illustrated.

- (i) Program play
- (j) Repeat of track being played
- (k) Repeat of all programmed tracks
- (l) Cancel repeat mode (Program play)

To return to program play

Press [REPEAT MODE] until "OFF" is displayed.

C Repeating sections between two specific points (A-B repeat)

1 Press [A-B REPEAT] during play at the point where repeat play is to start (A).

2 Press [A-B REPEAT] at the point where repeat play is to be concluded (B).

Repeat play of the section between points A and B starts.

To return to normal play

Press [A-B REPEAT] until "••" is displayed.

Note

- A-B repeat play does not work with interactive DVDs.
- Some subtitles recorded around point A or B may fail to appear (DVD).
- A-B repeat play works only within a title (DVD) or a track (Video CD/CD).

For your reference

- The unit automatically determines the end of a title/track as point B when the end of the title/track is reached.

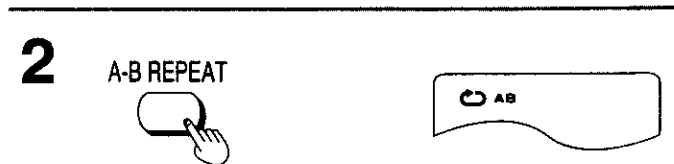
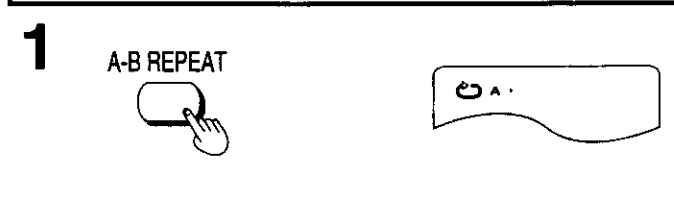
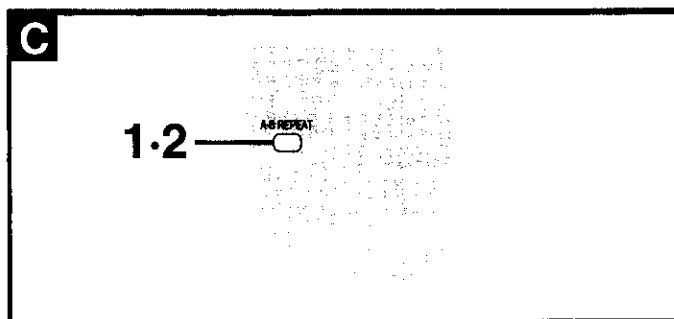
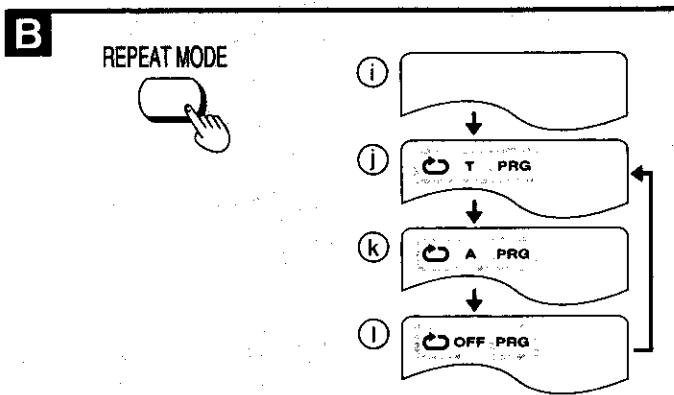
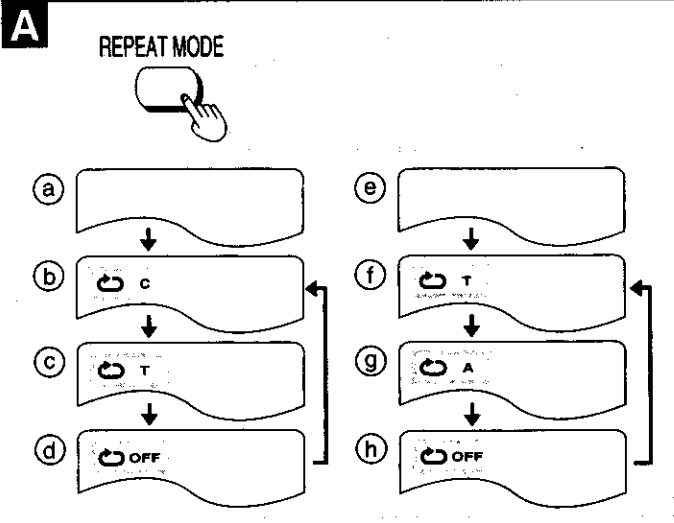
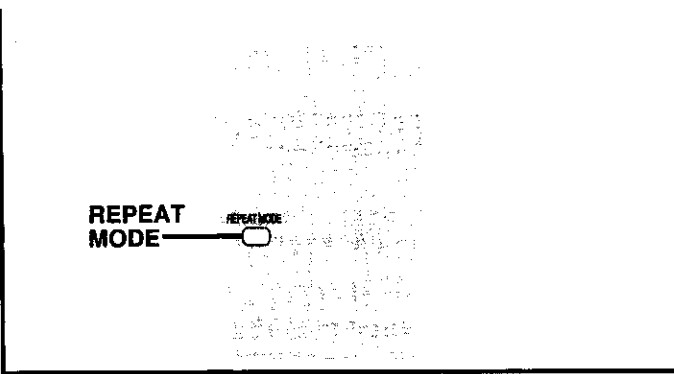

A Changing picture quality for movie viewing

DVD VCD

Press **[CINEMA]** on the unit while a disc is loaded.

The indicator lights.
Each time you press the button:

N: Normal mode



C: Cinema mode (Cinema position)

Mellows movies and enhances detail in dark scenes.

To restore the standard picture mode

Press **[CINEMA]**.

For your reference

• You can also use the On-Screen Menu Icons (⇒ "Ⓢ Cinema mode", page 25).

B Raising dialogue volume

DVD

This mode makes the dialogue in movies easier to hear (⇒ "Ⓢ Dialogue Enhancer", page 25).

This function is effective with Dolby Digital, 3 channels or over, where the dialogue is recorded in the center channel.

1 Press [DISPLAY] during play until the illustrated screen appears.

2 Press the cursor buttons [◀, ▶] to select the icon.

3 Press the cursor buttons [▲, ▼] to select the mode.

OFF: Normal volume

ON: Louder volume for dialogue

To clear the On-Screen Menu Icons

Press **[RETURN]** or **[CANCEL]**.

A

CINEMA button/indicator

CINEMA

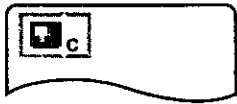

B

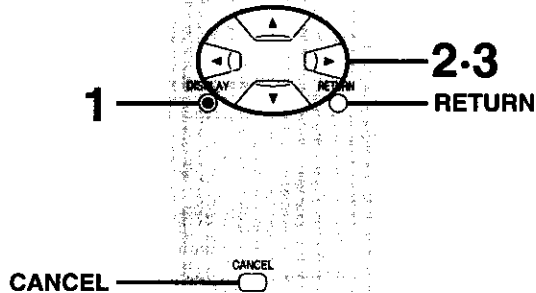

1

DISPLAY



2

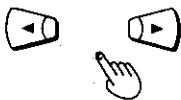

3

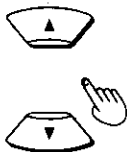

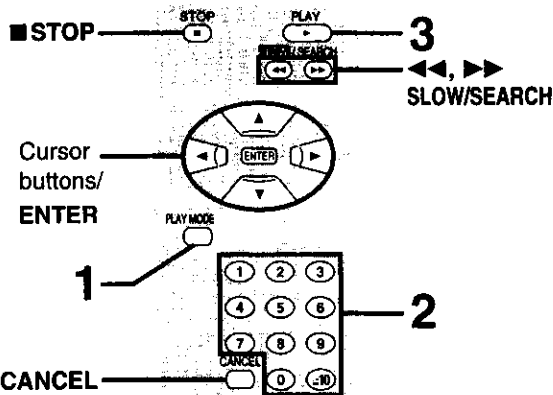

Advanced operations

Program play

VCD CD

The unit plays the tracks on a disc in the order you specify. You can program up to 32 tracks.

1 Press [PLAY MODE] while stopped until the illustrated screen appears.

- If "⊙" appears on the television, press [STOP] to cancel the RESUME function, then press [PLAY MODE].

2 Press the numeric buttons to select the track (⇒ item ⑩ on page 5 for number entry).

The selected track is stored in memory.

- If you press [ENTER], you can use the cursor buttons [▲, ▼] to select a track. Press [ENTER] to register the track number.
- Repeat step 2 to select another track.
- If you enter over 32 tracks, the last programmed track is replaced with the new one.

3 Press [▶ PLAY].

Play now begins in the programmed sequence.

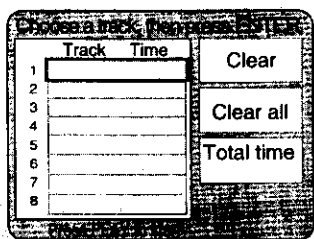

FL display (e.g. CD)

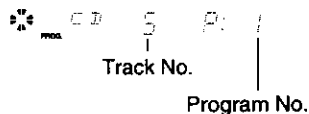
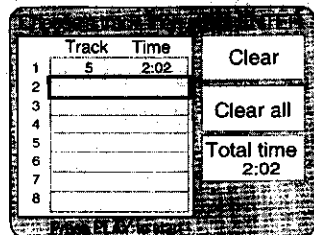
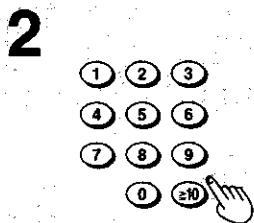
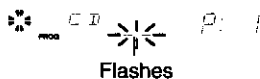

To exit the screen

Press [PLAY MODE] twice.

To add or change tracks

1. Press [STOP] twice during program play to show the program play screen.
 2. Press the cursor buttons [▲, ▼] to select an available item, then repeat program play step 2.
- Press [SLOW/SEARCH] to turn the program list pages to make the selection faster.

To return to normal play

1. Press [STOP] twice during program play. (Program play is suspended.)
 2. Press [PLAY MODE] twice.
 3. Press [PLAY].
- The program is retained in memory.

Operation by observing the unit's FL display

- Use the numeric buttons to enter track numbers.
- To check the program, press the cursor buttons [▲, ▼] while stopped. Each time you press the cursor buttons [▲, ▼], the program contents (track/program number) will be displayed.

Clearing the program

When the program play screen is displayed

- **To clear the programmed tracks one by one**
Select the track, move to "Clear" with the cursor buttons [▲, ▼, ◀, ▶] and press [ENTER]. (Selecting the track and pressing [CANCEL] also clears the programmed track.)
- **To clear the whole program**
Move to "Clear all" with the cursor buttons [▲, ▼, ◀, ▶] and press [ENTER]. (The program is also cleared when the unit is switched to the standby mode or turned off, or the disc tray is opened.)

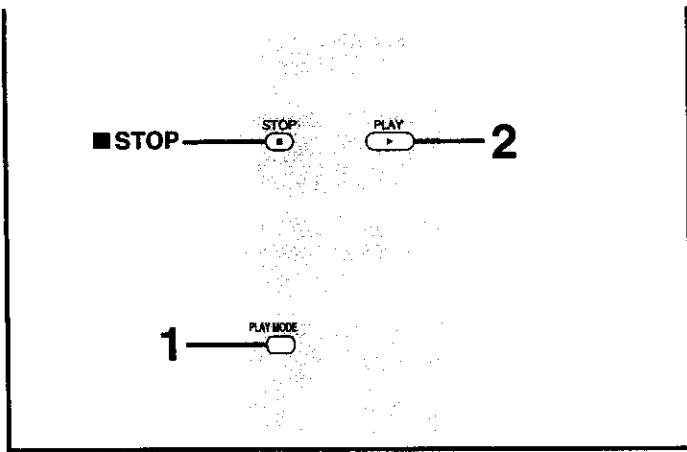

Random play

VCD CD

The unit plays the tracks on a disc in random order.

1 Press [PLAY MODE] while stopped until the illustrated screen appears.

- If "⊘" appears on the television, press [■ STOP] to cancel the RESUME function, then press [PLAY MODE].

2 Press [▶ PLAY].

Play now begins in random order.

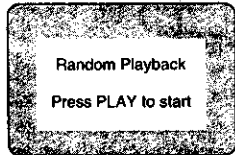
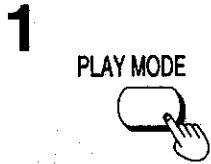

To exit the screen

Press [PLAY MODE] once.

To return to normal play

1. Press [■ STOP] twice during random play. (Random play is suspended.)
2. Press [PLAY MODE] once.
3. Press [▶ PLAY].

A Reproducing an advanced Virtual Surround Sound (V.S.S.) effect

DVD (Dolby Digital, 2-channel or over only)

Use this feature to enjoy a surround-like effect if you are using 2 front speakers.

Press [V.S.S.] during play.

Each time you press the button, the unit's FL display changes:

- (a) V.S.S. 1 (Natural effect)
- (b) V.S.S. 2 (Emphasized effect)
- (c) V.S.S. is canceled

• The V.S.S. indicator lights up when V.S.S. is on.

Note

- V.S.S. does not work with Karaoke DVDs.
- V.S.S. will not work or will have less effect with some discs.
- Turn off the TV surround sound and other surround sound effects when using this effect.
- Sound will only come from the two front speakers if V.S.S. is on.

For your reference

- For optimum effect, it is recommended that the distance between the television and the listening position be about 3 to 4 times the distance between the right and left front speakers. **B**
- You can also change the V.S.S. level with the On-Screen Menu Icons [→] "Ⓜ Virtual Surround Sound (V.S.S.)", page 25].

• V.S.S. effects

	Stereo discs	Surround signal recorded discs
V.S.S. 1	The front speakers sound farther apart.	Surround sound seems to come from the side.
V.S.S. 2	The surround-like effect in V.S.S. 1 is enhanced.	

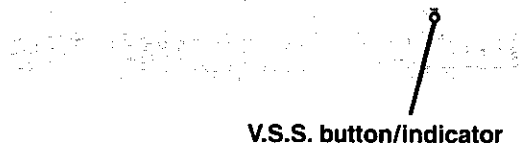

V.S.S. button/indicator

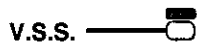

A

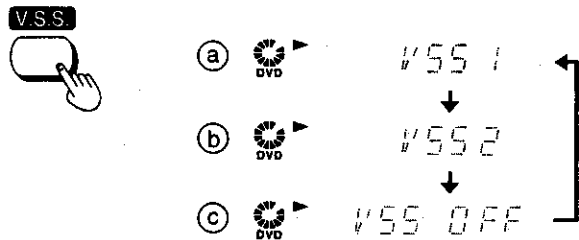

B

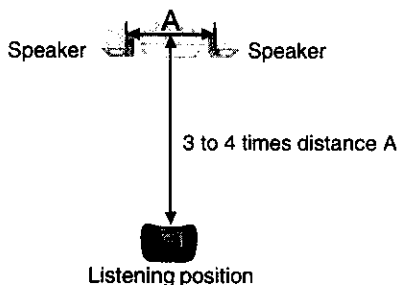

Using On-Screen Menu Icons

On-Screen Menu Icons

On-Screen Menu Icons are long thin menus that contain information about the disc or unit. These menus allow you to perform operations by changing this information.

Examples of On-Screen Menu Icons A
The screens depend on the disc contents.

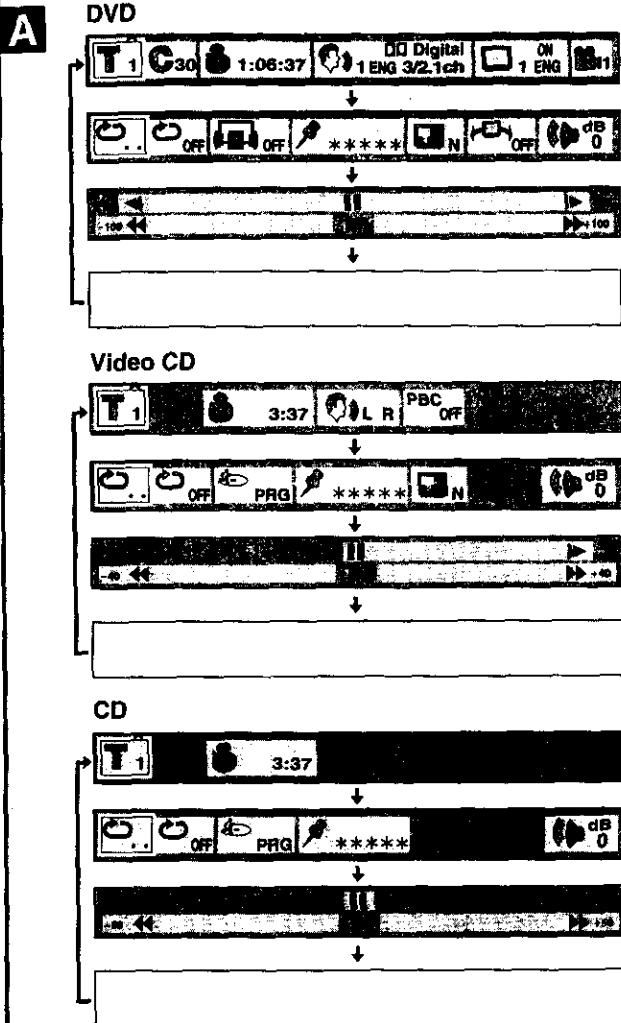

B Common procedures

1 Press [DISPLAY] during play or in the stop mode.

Each time you press the button, the TV monitor changes as follows:

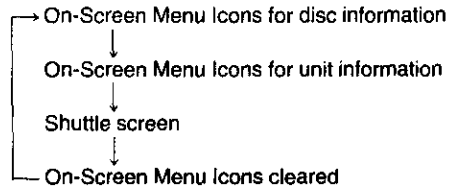

•Some functions cannot be accessed from the stop mode.

2 Press the cursor buttons [◀, ▶] to select the item.

The item is highlighted in yellow.

3 Press the cursor buttons [▲, ▼] to select the setting.

- For some functions, the setting will be registered immediately; for others, [ENTER] or [▶ PLAY] must be pressed.
- When numbers are displayed (e.g. title No.), both the numeric buttons and the cursor buttons [▲, ▼] are also effective for setting. When numbers are entered with numeric buttons, press [ENTER] to register the setting.

To clear the On-Screen Menu Icons
Press [RETURN] or [CANCEL].

For your reference

- The On-Screen Menu Icons may not be displayed when playing some kinds of DVD software, or if the television's automatic picture zoom function is on. Change the position of the On-Screen Menu Icons in "4 On-Screen Messages" if this occurs (⇒ page 29).
- The color (blue, violet or green) of the On-Screen Menu Icons can also be changed (⇒ page 29).
- "▲, ▼" around the icon means that the item can be changed using the cursor buttons [▲, ▼].

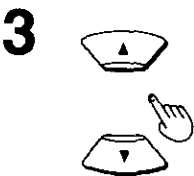
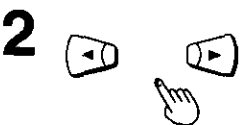
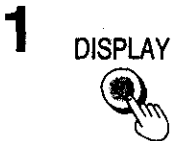
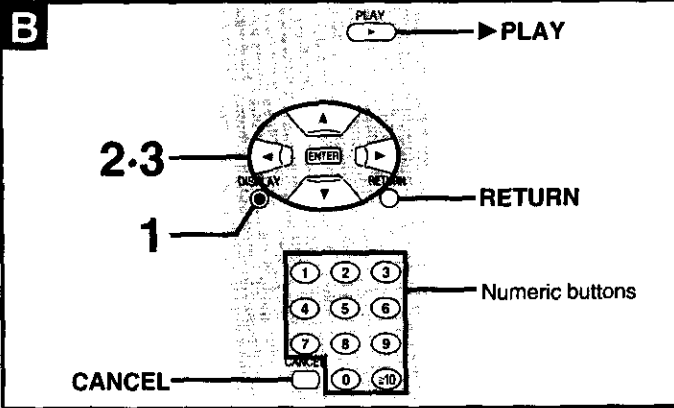

Detailed descriptions of each icon

Screen for disc information

■ DVD

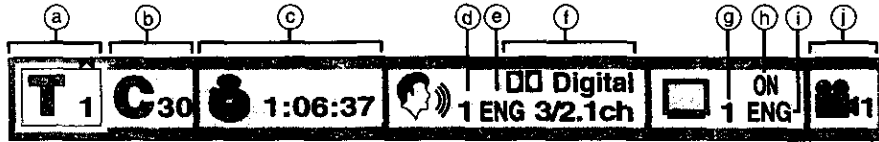

- ⓐ **Title No.**
Change the No. with the cursor buttons [▲, ▼] or the numeric buttons, and press [ENTER].
- ⓑ **Chapter No.**
Change the No. with the cursor buttons [▲, ▼] or the numeric buttons, and press [ENTER].
- ⓒ **Time**
(hour:minute:second)
Enter the time from which you want to start play and press [ENTER].
Example: To specify "1 hour 6 min. 37 sec.", enter "10637".
- ⓓ **Soundtrack language No.**
Change the No. with the cursor buttons [▲, ▼] or the numeric buttons.
- ⓔ **Soundtrack language**

ENG: English	SVE: Swedish	CHI: Chinese
FRA: French	NOR: Norwegian	KOR: Korean
DEU: German	DAN: Danish	MAL: Malay
ITA: Italian	POR: Portuguese	VIE: Vietnamese
ESP: Spanish	RUS: Russian	THA: Thai
NLD: Dutch	JPN: Japanese	*: Others

- ⓑ **Audio attribute**
Shows the audio attributes of the selected soundtrack (cannot be changed).
LPCM/Digital/DTS: Signal type
k: Sampling frequency (kHz)
b: Number of bits (bit)
ch: Number of channels*
Vocal: Vocals indication
• You can switch vocals ON or OFF with the cursor buttons [▲, ▼].
[DVD Karaoke (Solo)]: --- (OFF) or ON
[DVD Karaoke (Duet)]: --- (OFF), V1+V2, V1 or V2
- ⓓ **Subtitle language No.**
Change the No. with the cursor buttons [▲, ▼] or the numeric buttons.
- ⓔ **Subtitle on/off**
Select "ON" or "OFF" with the cursor buttons [▲, ▼].
OFF: Subtitle is cleared.
ON: Subtitle is displayed.
- ⓑ **Subtitle language**
See the table under the item ⓔ.
- ⓑ **Angle No.**
Change the No. with the cursor buttons [▲, ▼] or the numeric buttons.

■ Video CD/CD

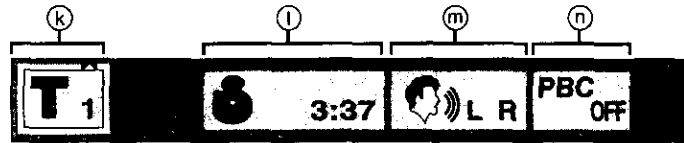

- ⓑ **Track No.**
Change the No. with the cursor buttons [▲, ▼] or the numeric buttons, and press [ENTER].
- ⓑ **Time**
(minute:second)
Display is changed each time the cursor buttons [▲, ▼] are pressed. (The times cannot be changed)
Elapsed playing time ← → Remaining time of the track
↑ → Remaining time of the disc ← →

- ⓑ **Audio mode VCD**
Change the mode with the cursor buttons [▲, ▼].
LR: Left channel sound is output from the left speaker (L), and right channel sound is output from the right speaker (R).
L: Left channel sound only is output from the speakers (L/R).
R: Right channel sound only is output from the speakers (L/R).
- ⓑ **Playback control VCD**
Shows whether menu play is on or off (cannot be changed here).
OFF: Menu play is OFF.
ON: Menu play is ON.

Note

- Actual information displayed depends on the disc.
- During program and random play of Video CDs and CDs, the remaining time of the disc is not displayed.

※Example:
3/2 .1ch

.1:	Subwoofer signal (not displayed if there is no subwoofer signal)
0:	No surround
1:	Mono surround
2:	Stereo surround (left/right)
1:	Center
2:	Front left+Front right
3:	Front left+Front right+Center

Screen for unit information

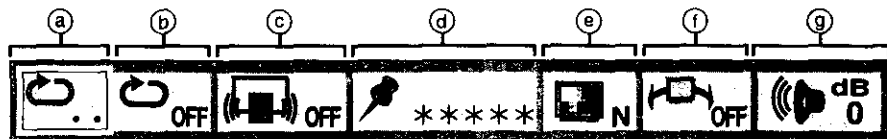

a A-B repeat play

Press [ENTER] during play to store location A and press [ENTER] again to store location B. Repeat play between the 2 locations starts. Press [ENTER] again to return to normal play.

b Repeat play

Select the mode during play with the cursor buttons [▲, ▼].

DVD

OFF: Normal play
C: Chapter repeat play
T: Title repeat play

VCD CD

OFF: Normal play
T: Track repeat play
A: Disc repeat play

c Dialogue Enhancer (⇒ page 19)

DVD



Select the mode during play with the cursor buttons [▲, ▼].

OFF: Normal volume
ON: Louder volume for dialogue
Play mode (⇒ pages 20 and 21)

VCD CD

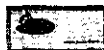

The current play mode is shown (cannot be changed here).

PRG: Program play
RND: Random play
----: Normal play

d Marker (Marking parts you want to watch or listen to again)

Press [ENTER] during play and press [ENTER] again at the preferred point to store a marker. (Marker no. replaces "*"). Up to 5 markers can be stored in memory.

To store the next marker, press the cursor button [▶].

•To recall a marker

Select the marker no. with the cursor buttons [◀, ▶] and press [ENTER].

•To clear a marker

Select the marker no. with the cursor buttons [◀, ▶] and press [CANCEL].

•Some subtitles recorded around the marker may fail to appear.

•All the markers are cleared when the player is switched to the standby mode or turned off, or the disc tray is opened.

e Cinema mode (⇒ page 19)

DVD VCD

Select the mode with the cursor buttons [▲, ▼] while a disc is loaded.

N: Normal mode
C: Cinema mode (Cinema position): Picture for viewing movies

f Virtual Surround Sound (V.S.S.) (⇒ page 22)

DVD (Dolby Digital, 2-channel or over only)

Select the level during play with the cursor buttons [▲, ▼].

OFF: V.S.S. off

1: V.S.S. natural effect
2: V.S.S. emphasized effect

g Master volume

Adjust the master volume with the cursor buttons [▲, ▼].

–∞ or –127 to 0 (dB)

Note

- A-B repeat play does not work with an interactive DVD.
- Repeat play and marker functions do not work with an interactive DVD or during menu play of a Video CD with playback control.
- Dialogue Enhancer is effective with Dolby Digital, 3 channels or over, where the dialogue is recorded in the center channel.

Shuttle screen

Maximum speed
 DVD: –100
 Video CD: –40
 CD: –50

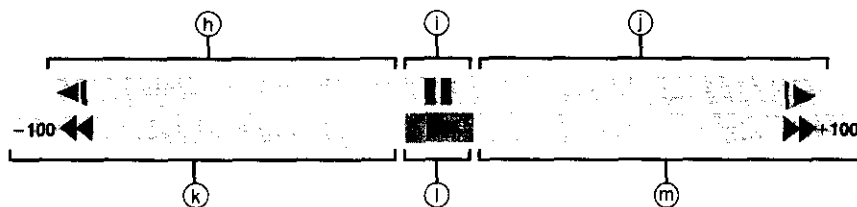

Maximum speed
 DVD: +100
 Video CD: +40
 CD: +50

h Slow-motion play (Backward) **DVD**

Press the cursor buttons [▲]→[◀].

i Still/Pause

Press the cursor buttons [▲].

j Slow-motion play (Forward) **DVD VCD**

Press the cursor buttons [▲]→[▶].

k Rapid reverse

Press the cursor buttons [▼]→[◀].

l Play

Press the cursor button [▼].

m Rapid advance

Press the cursor buttons [▼]→[▶].

For your reference

- Each time the cursor buttons [◀, ▶] are pressed, the speed of rapid reverse/advance and slow-motion play increases up to 5 steps.

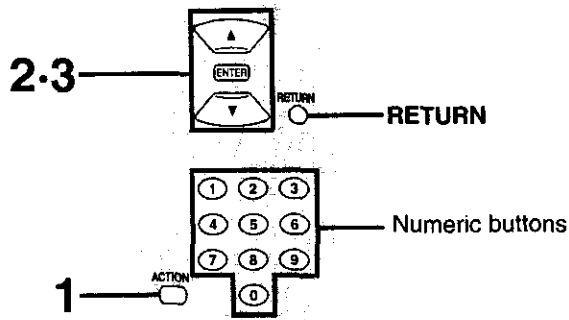

1 ACTION

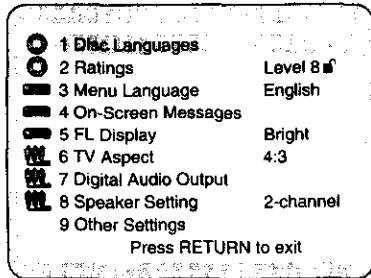

2

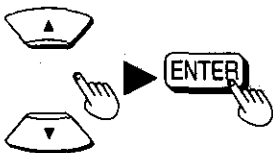

3

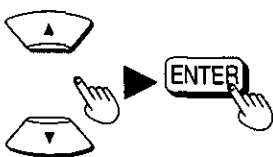

Changing initial settings

Change the initial settings to suit your preference and to suit the unit to the environment in which it is being used.

Common procedures

1 Press [ACTION] in the stop mode.

The initial settings screen is displayed.

2 Press the cursor buttons [▲, ▼] to select the item and press [ENTER].

Each item that can be modified is displayed.

1 Disc Languages (⇒ page 27)

Change the soundtrack language, subtitle language and the language used in the disc's menu to be used for every disc played.

2 Ratings (⇒ page 28)

Change the ratings level to prevent play of discs, skip violent scenes, or replace scenes with others by entering a password. This is also called a parental lock.

3 Menu Language (⇒ page 29)

Change the language used for the on-screen displays and initial settings menus.

4 On-Screen Messages (⇒ page 29)

Choose whether "Play", "Still" and other displays will be displayed or not, and the color and position of these displays as well as On-Screen Menu Icons.

5 FL Display (⇒ page 29)

Change the brightness for the FL display.

6 TV Aspect (⇒ page 10)

Change the settings to suit the type of television you have connected.

7 Digital Audio Output (⇒ page 36)

Change the settings to suit the type of digital equipment you have connected.

8 Speaker Setting (⇒ page 38)

Change the settings to suit the type of speaker you have connected.

9 Other Settings (⇒ page 30)

Choose the kind of picture shown when play is paused, and adjust various other settings to enhance your viewing experience.

3 Press the cursor buttons [▲, ▼] to select the setting and press [ENTER].

•Some items require additional steps. (See the respective pages.)

Setting is finished and the initial settings screen is displayed.

To cancel during setup operation

Press [RETURN]. (The previous screen is displayed.)

To exit the initial settings screen

Press [ACTION] or [RETURN].

For your reference

•The numeric buttons can also be used instead of the cursor buttons [▲, ▼] for selecting items or settings. Pressing [ENTER] is not necessary.

1 Disc Languages

DVD

See page 26 for operation.

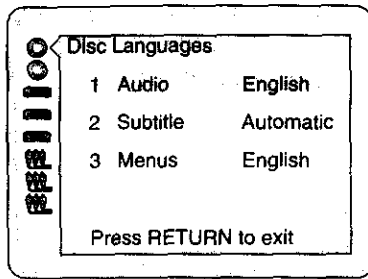

1 Audio	<p>1 English (Factory preset) 2 French 3 Spanish</p> <p>4 Original The original language of each disc will be selected.</p> <p>5 Other * * * * Another language can be selected.*</p>
2 Subtitle	<p>1 Automatic (Factory preset) Subtitle language will automatically be selected in accordance with the soundtrack language.</p> <ul style="list-style-type: none"> • If the language selected for the "1 Audio" is actually used during playback, the subtitles will not appear. • If another language is used during playback, the subtitles will appear in the language selected at the setup "1 Audio". <p>2 English 3 French 4 Spanish</p> <p>5 Other * * * * Another language can be selected.*</p>
3 Menus	<p>1 English (Factory preset) 2 French 3 Spanish</p> <p>4 Other * * * * Another language can be selected.*</p>

*Enter the language code if you select "Other". (See the language code list below.) Press [CANCEL] if you enter the number incorrectly.

Note

- If the language selected is not available on the disc, the language designated by each disc will be selected.
- There are cases where the selected language is recorded but the disc designates another language.

Advanced operations

Language code list

6566: Abkhazian	9072: Chinese	7265: Hausa	7684: Lithuanian	8279: Romanian	8469: Telugu
6565: Afar	6779: Corsican	7387: Hebrew	7775: Macedonian	8285: Russian	8472: Thai
6570: Afrikaans	7282: Croatian	7273: Hindi	7771: Malagasy	8377: Samoan	6679: Tibetan
8381: Albanian	6783: Czech	7285: Hungarian	7783: Malay	8365: Sanskrit	8473: Tigrinya
6577: Ameharic	6865: Danish	7383: Icelandic	7776: Malayalam	7168: Scots Gaelic	8479: Tonga
6582: Arabic	7876: Dutch	7378: Indonesian	7784: Maltese	8382: Serbian	8482: Turkish
7289: Armenian	6978: English	7365: Interlingua	7773: Maori	8372: Serbo-Croatian	8475: Turkmen
6583: Assamese	6979: Esperanto	7165: Irish	7782: Marathi	8378: Shona	8487: Twi
6588: Aymara	6984: Estonian	7384: Italian	7779: Moldavian	8368: Sindhi	8575: Ukrainian
6590: Azerbaijani	7079: Faroese	7465: Japanese	7778: Mongolian	8373: Singhalese	8582: Urdu
6665: Bashkir	7074: Fiji	7487: Javanese	7865: Nauru	8375: Slovak	8590: Uzbek
6985: Basque	7073: Finnish	7578: Kannada	7869: Nepali	8376: Slovenian	8673: Vietnamese
6678: Bengali; Bangla	7082: French	7583: Kashmiri	7879: Norwegian	8379: Somali	8679: Volapük
6890: Bhutani	7089: Frisian	7575: Kazakh	7982: Oriya	6983: Spanish	6789: Welsh
6672: Bihari	7176: Galician	7589: Kirghiz	8083: Pashto, Pushto	8385: Sundanese	8779: Wolof
6682: Breton	7565: Georgian	7579: Korean	7065: Persian	8387: Swahili	8872: Xhosa
6671: Bulgarian	6869: German	7585: Kurdish	8076: Polish	8386: Swedish	7473: Yiddish
7789: Burmese	6976: Greek	7679: Laotian	8084: Portuguese	8476: Tagalog	8979: Yoruba
6669: Byelorussian	7576: Greenlandic	7665: Latin	8065: Punjabi	8471: Tajik	9085: Zulu
7577: Cambodian	7178: Guarani	7686: Latvian, Lettish	8185: Quechua	8465: Tamil	
6765: Catalan	7185: Gujarati	7678: Lingala	8277: Rhaeto-Romance	8484: Tatar	

2 Ratings

DVD

See page 26 for operation.

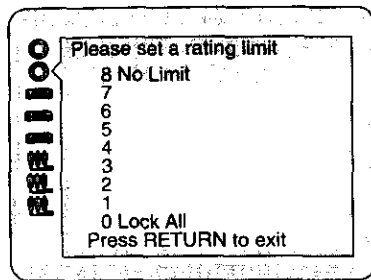

Level 8 (Factory preset)
All DVDs can be played.

Level 7 to 1
Prevents play of DVDs with ratings recorded on them (those that contain adult or violent scenes).

Level 0
Play of all DVDs is prohibited (e.g. to prohibit play of adult DVDs which are not encoded with rating information).

Note

- The rating method differs from disc to disc. There are discs designed for adults that do not have these ratings recorded on them. These discs can be played as normal. To prevent play of these discs, set the rating limit to "0 Lock All".

Setting ratings (When the level is "8")

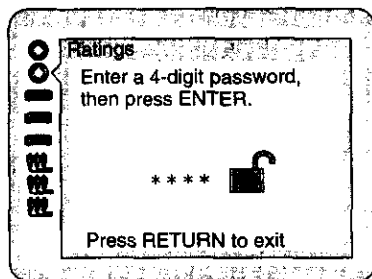

1 Select the level with the cursor buttons [**▲**, **▼**] and press [**ENTER**].

2 Enter a 4-digit password with the numeric buttons and press [**ENTER**].

- Press [**CANCEL**] if you enter the number incorrectly. The lock symbol appears closed to show the rating is locked. Do not forget your password.

3 Press [**ENTER**].

Setting is finished and the initial settings screen is displayed.

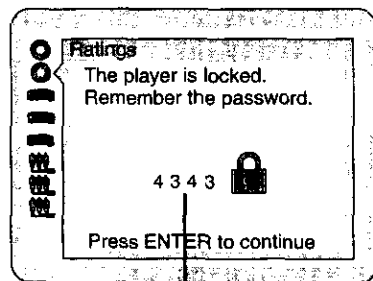

Example: "4343"

Now, when you insert a DVD that exceeds the ratings limit you set, a message appears on the television. If you want to play the disc, select "Yes" and enter your password. The unit will unlock temporarily, locking again when the disc tray is opened or the unit is turned off.

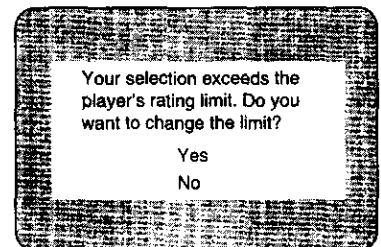

Changing ratings (When the level is "0" to "7")

Changes to the settings also requires a password.

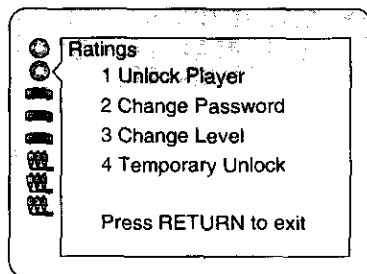

1 Press the cursor buttons [**▲**, **▼**] to select "2 Ratings" in the initial settings screen and press [**ENTER**].

2 Enter your 4-digit password with the numeric buttons and press [**ENTER**].

3 Press the cursor buttons [**▲**, **▼**] to select the item.

To unlock the unit (the rating level returns to "8")
Select "1" and then press [**ENTER**].

To change the password

Select "2" and press [**ENTER**]. Enter a new 4-digit password and press [**ENTER**], then press [**ENTER**] again.

To change the rating level

Select "3" and press [**ENTER**]. Select a new level with the cursor buttons [**▲**, **▼**], then press [**ENTER**].

To unlock the unit temporarily

Select "4" and then press [**ENTER**].

- The rating is unlocked temporarily for the current disc. The unit is locked again when the disc tray is opened or the unit is switched to the standby mode or turned off.

3 Menu Language

See page 26 for operation.

Example: If you selected "2 Français"

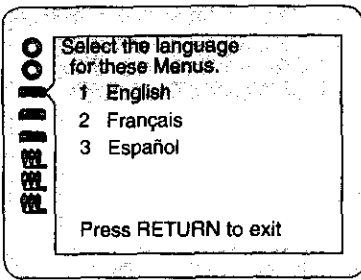



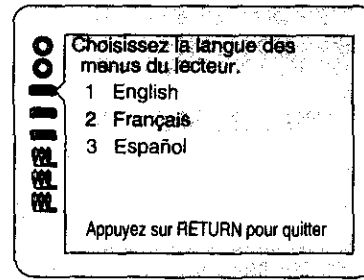



- 1 English (Factory preset)
- 2 Français
- 3 Español

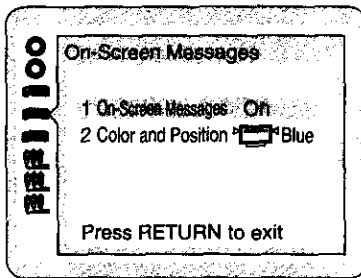

4 On-Screen Messages

See page 26 for operation.



1 On-Screen Messages	<ul style="list-style-type: none"> 1 On (Factory preset) 2 Off
2 Color and Position	<ul style="list-style-type: none"> 1  Blue (Factory preset) 2  Violet 3  Green 4  Blue 5  Violet 6  Green <p style="margin-left: 150px;">} Shown slightly lower. Select if the top of the screen is cut off.</p>

Advanced operations

5 FL Display

See page 26 for operation.

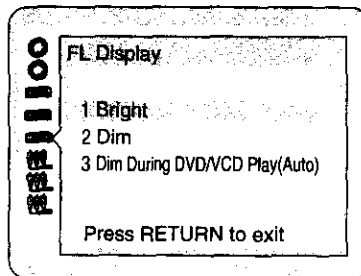

- 1 **Bright** (Factory preset)
- 2 **Dim**
- 3 **Dim During DVD/VCD Play (Auto)**
The FL display will be dimmed during play of DVDs and Video CDs. The display brightens when you press a button for special play such as [◀◀, ▶▶ SLOW/SEARCH] or [⏸ PAUSE].

9 Other Settings

See page 26 for operation.

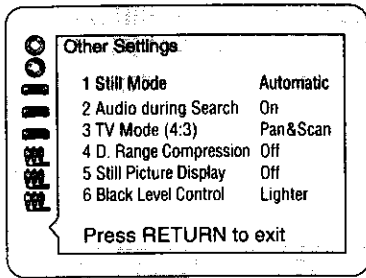

Advanced operations

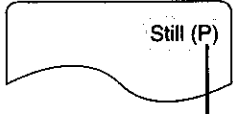
<p>1 Still Mode Select either "Field still" or "Frame still" in the still picture mode.</p>	<p>1 Automatic (Factory preset) 2 Field Select this setting when jittering occurs in the still picture mode when "1 Automatic" is selected. 3 Frame Select if small text or fine patterns cannot be seen clearly in the still picture mode when "1 Automatic" is selected.</p>
<p>2 Audio during Search To select whether audio is heard or not during search (forward direction) at the initial search speed.</p>	<p>1 On (Factory preset) 2 Off</p>
<p>3 TV Mode (4:3) To select whether widescreen material is played in the pan and scan style or in the letterbox style on a conventional TV (4:3).</p>	<p>1 Pan & Scan (Factory preset) Widescreen video material will be played in the pan and scan style (the picture is shown with either one or both sides cut off) on a conventional television (4:3). • Video material not formatted in the pan and scan style will be played in the letterbox style. 2 Letterbox Widescreen video material will be played in the letterbox style (black bands appear at the top and bottom of the screen) on a conventional television (4:3).</p>
<p>4 D. (Dynamic) Range Compression To compress the dynamic range (the difference between the loudest sound and the softest sound), making it easier to hear dialogue even at low volume. This function only works with Dolby Digital DVD.</p>	<p>1 Off (Factory preset) The dynamic range remains as it was recorded on the disc. 2 On Dynamic range is compressed by augmenting soft sounds and reducing loud sounds. Select when playing discs at low volume, such as late at night.</p>
<p>5 Still Picture Display To display the picture type (DVD), I, P or B in the still picture mode.</p>	<p>1 Off (Factory preset) 2 On</p> <div style="text-align: center;">  <p>Example: P-picture</p> </div>
<p>6 Black Level Control To select the black level of the picture, "Lighter" or "Darker".</p>	<p>1 Lighter (Factory preset) Select when the unit is connected to a TV through the VIDEO OUT terminal or S VIDEO OUT terminal. 2 Darker Select when the unit is connected to a TV through the COMPONENT VIDEO OUT (Y/P_B/P_R) terminals.</p>

Note

- Audio is heard at any speed when playing CDs, regardless of any settings at "2 Audio during Search".
- Audio is not heard at any speed when playing CDs encoded with DTS, regardless of any settings at "2 Audio during Search".

For your reference

● **I/P/B**

To efficiently store video on DVD, common elements among frames are used in common, and different elements are recorded with each individual frame. The frame that contains the common elements is called an I-picture, a complete frame in itself. A P-picture is calculated from past I or P-pictures. The frame that fills in the spaces between the I-and P-pictures is called the B-picture.

I-pictures have the best picture quality, so they should be used when making picture adjustments.

● **Frame**

Individual images in a video or on the television are called frames.

● **Field**

Half of the video information (video signal) in a frame is called a field. With conventional TV systems, a single frame (a single screen) consists of two fields.

● **Frame still**

The two fields are displayed alternately on the TV screen, so the image may be blurry. However, the image quality is better than field images.

● **Field still**





















Only one field (half of the video information) is displayed on the TV screen, so the apparent resolution is low. However, there is no blurring on the screen.

How different kinds of software appear on your television

DVD software is recorded in a variety of picture formats, and how they appear on your TV depends on the software, the kind of TV you have, and the picture mode your TV is set to.

● **Letterbox** refers to pictures where black bands appear at the top and bottom.

● **Pan and scan** refers to pictures where part of the picture is cut off so it fills the whole screen.

Television and picture mode Software format	4:3	16:9 full mode	16:9 zoom mode	16:9 auto mode
Widescreen, pan and scan 	Edges cut off 	Full screen 	Top and bottom cut off 	Full screen 
Widescreen, non-pan and scan 	Letterbox 			
Regular (4:3) 	Full screen 	Screen stretched horizontally 	Top and bottom cut off 	Full screen with black bands at right and left 
Regular (4:3) letterbox 	Letterbox 	Letterbox with screen stretched horizontally 	Full screen 	Letterbox with extremities of picture stretched 

The names given to the television picture modes depends on your television. There may also be slight differences in how the pictures appear on the screen. Refer to your television's operating instructions for details.

Home theater

■ Upgrading your audio equipment

Setup chart						
Types of connection	Equipment and settings	Equipment	Speakers	Settings in "8 Speaker Setting"	Settings in "7 Digital Audio Output"	Page
To enjoy the 5.1-channel surround sound found on DVDs using the unit's built-in decoder*1	Amplifier with 5.1-channel audio input terminals		<ul style="list-style-type: none"> ● Front speakers (L/R) ● Subwoofer ● Surround speakers (L/R) ● Center speaker 	Select "1 Multi-channel" <ul style="list-style-type: none"> ● Speaker presence ⇒ Set speakers you have connected to "Yes" ● Set delay time if necessary ● Correct output balance if necessary 	PCM Down Conversion⇒"No"	A 33
To enjoy the 5.1-channel surround sound found on DVDs using the decoder in another unit	Amplifier with built-in decoder or a separate decoder-amplifier combination*2		<ul style="list-style-type: none"> ● Front speakers (L/R) ● Subwoofer ● Surround speakers (L/R) ● Center speaker 	No settings required	<ul style="list-style-type: none"> ● PCM Down Conversion⇒"Yes" ● Dolby Digital/DTS Digital Surround ⇒ Settings depend on your decoding equipment 	B 34
To enjoy stereo through a digital amplifier*3	Audio equipment with digital audio input terminals		Front speakers (L/R)	No settings required	<ul style="list-style-type: none"> ● PCM Down Conversion⇒"Yes" ● Dolby Digital⇒"PCM" ● DTS Digital Surround ⇒"Off" 	C 35
To enjoy stereo through an analog amplifier*3	Analog amplifier or system component with 2-channel audio input terminals		Front speakers (L/R)	Select "2 2-channel"	PCM Down Conversion⇒"No"	D 35

*1 This unit does not have a DTS Digital Surround decoder, but it can output the bitstream. Use the connection described in **B** on page 34 to enjoy DVDs encoded with DTS.

*2 Connect speakers if necessary and make the speaker settings on the amplifier.

*3 If you have connected an amplifier with Dolby Pro Logic decoder, you may need to connect center and surround speakers.

■ Upgrading your television

● You can connect CRT projectors, LCD projectors, and projection televisions.

● See "Connection to a television" (⇒ pages 8 and 9) for details on connection.

Note

● The equipment connections described are examples.

● Peripheral equipment and optional cables sold separately unless otherwise indicated.

A Connecting an amplifier with 5.1-channel audio input terminals

This unit can decode Dolby Digital. Connect an amplifier with 5.1-channel discrete input terminals to enjoy surround sound.

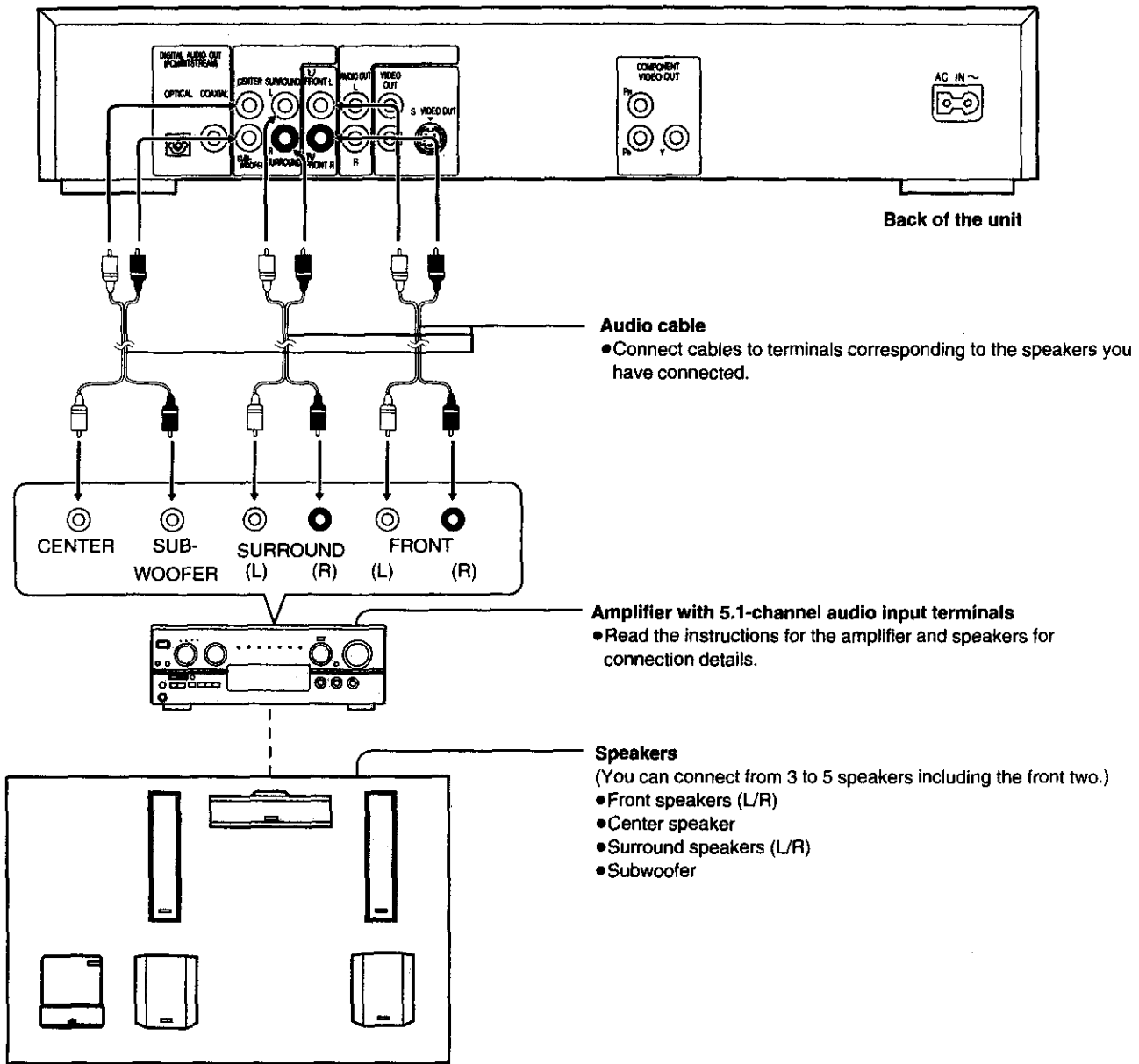

Home theater

When you have finished connection

- In "8 Speaker Setting", select "1 Multi-channel" and make changes to suit your speakers (⇒ page 38).

Speaker presence: Select "Yes" if the corresponding speaker is connected.

Select "No" if the corresponding speaker is not connected.

Center and surround speaker delay time: Adjust if you cannot place your speakers in the optimum position.

Channel balance: Adjust the output level of the speakers to make up for differences in volume caused by different types of speaker or distance.

- Go to "7 Digital Audio Output" and set "1 PCM Down Conversion" to "No" (⇒ page 36).

Note

- Turn off V.S.S. (⇒ page 22) if you have connected a subwoofer, center speaker, or surround speakers as well as the front speakers. Sound will not come from the other speakers if V.S.S. is on.
- Use the connection described in **B** on page 34 to enjoy DVDs encoded with DTS.

B Connecting an amplifier with built-in decoder

You can enjoy the 5.1-channel surround sound found on DVD recorded with Dolby Digital or DTS Digital Surround by connecting an amplifier with a built-in decoder or a separate decoder-amplifier combination.

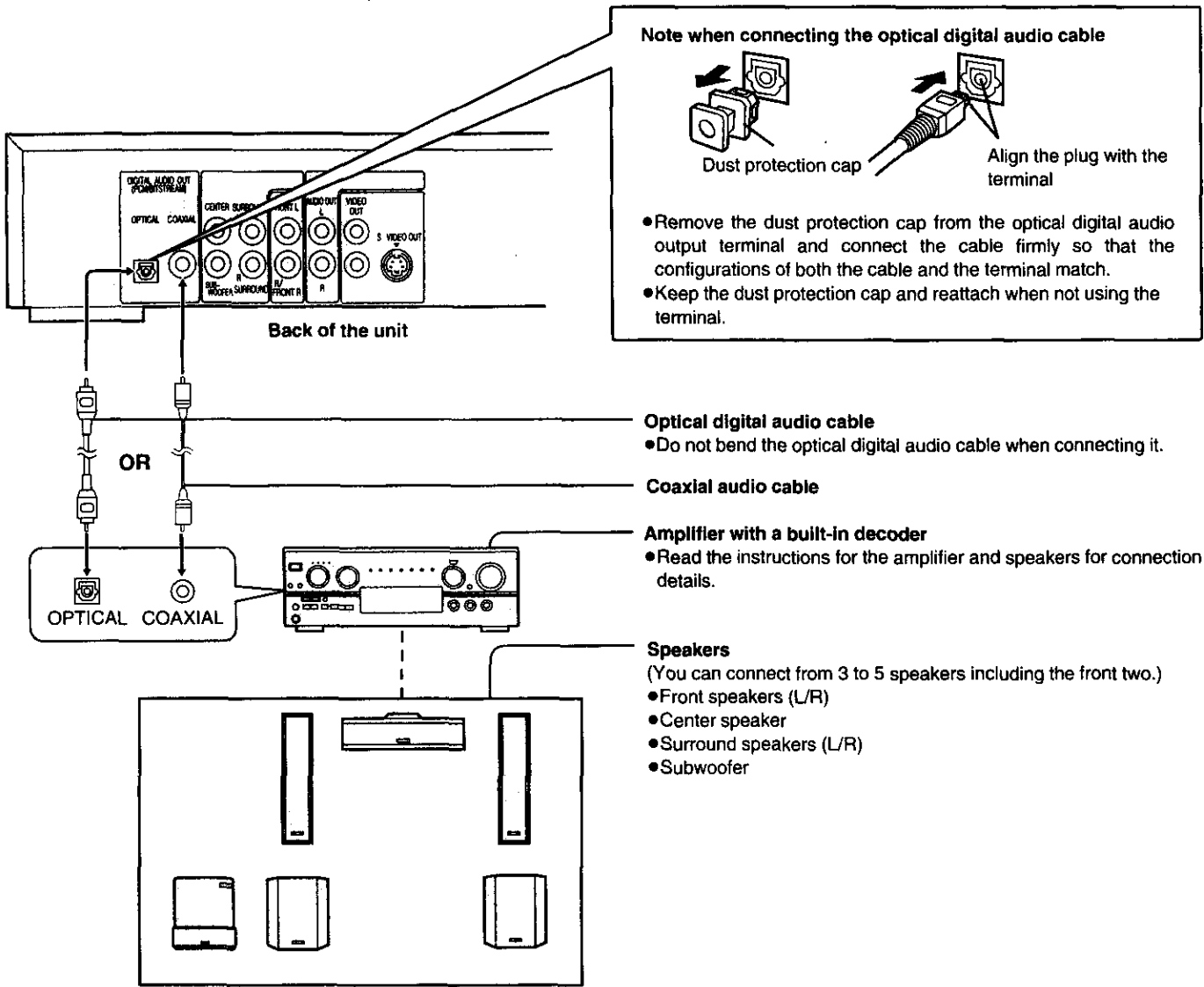

When you have finished connection

Make changes to "7 Digital Audio Output" to suit your decoder (⇒ page 36).

Item	Decoder		
	Dolby Digital decoder	DTS Digital Surround decoder	Dolby Digital/ DTS Digital Surround decoder
PCM Down Conversion	Yes*	Yes*	Yes*
Dolby Digital	Bitstream	PCM	Bitstream
DTS Digital Surround	Off	Bitstream	Bitstream

*If this is set to "No", no audio will be output when DVDs recorded in 96 kHz linear PCM are played. (Audio will be output as it is if the DVD does not have copyright protection recorded on it.)

•These changes to digital audio output must be made, otherwise bitstream signals the decoder cannot handle will be output. If these signals are output, "noise" will be output which can cause harm to your ears and speakers.

Note

•You cannot use DTS Digital Surround decoders not suited to DVD.

C Connecting audio equipment with digital audio input terminals

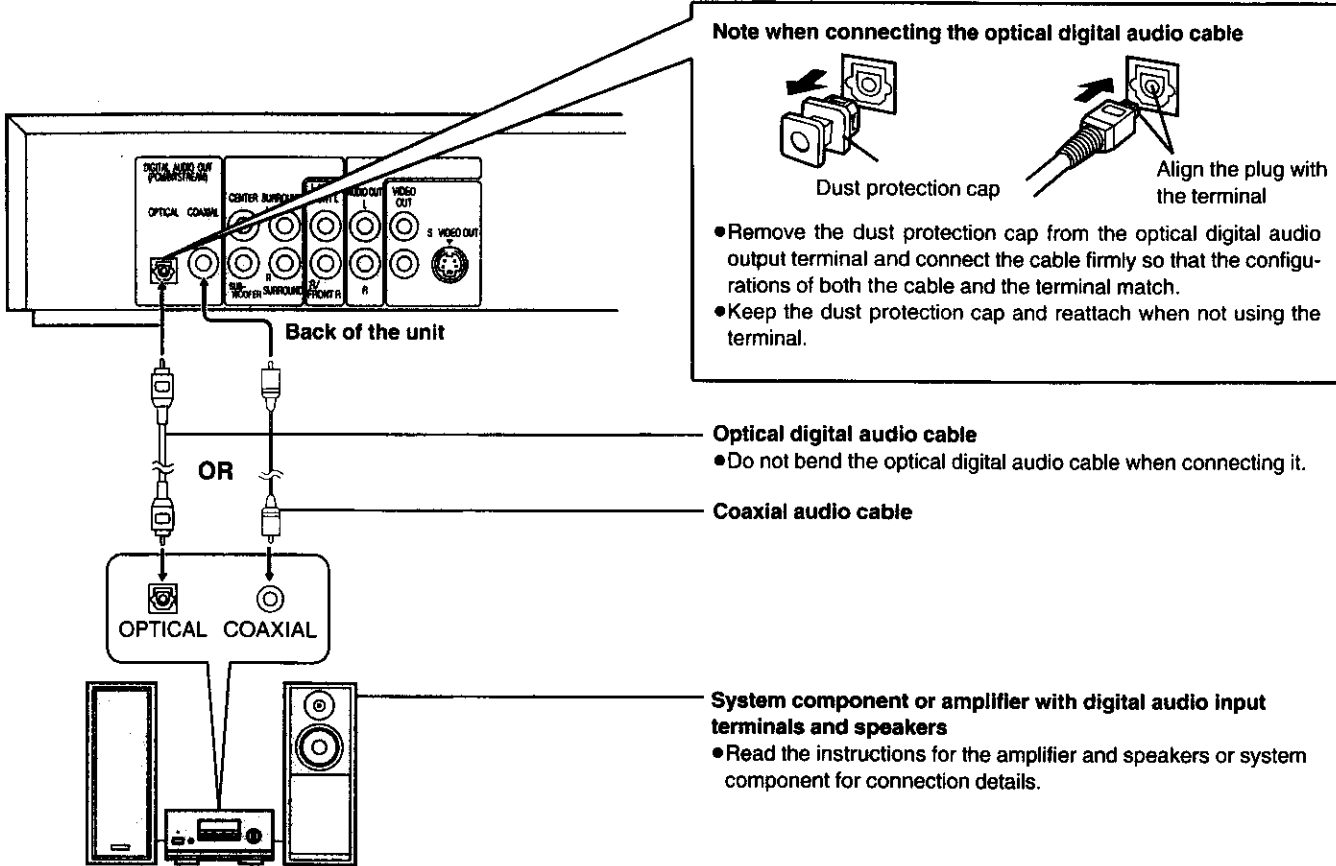

When you have finished connection

Make changes to "7 Digital Audio Output" as shown (⇒ page 36).

PCM Down Conversion	Yes*
Dolby Digital	PCM
DTS Digital Surround	Off

*If this is set to "No", no audio will be output when DVDs recorded in 96 kHz linear PCM are played. (Audio will be output as it is if the DVD does not have copyright protection recorded on it.)

•These changes to digital audio output must be made, otherwise signals the equipment cannot handle, bitstream, will be output. If the signals are output as bitstream, "noise" will be output which can cause harm to your ears and speakers.

D Connecting audio equipment with 2-channel audio input terminals

You can enjoy stereo sound if you connect an amplifier or system component that has 2-channel audio input terminals.

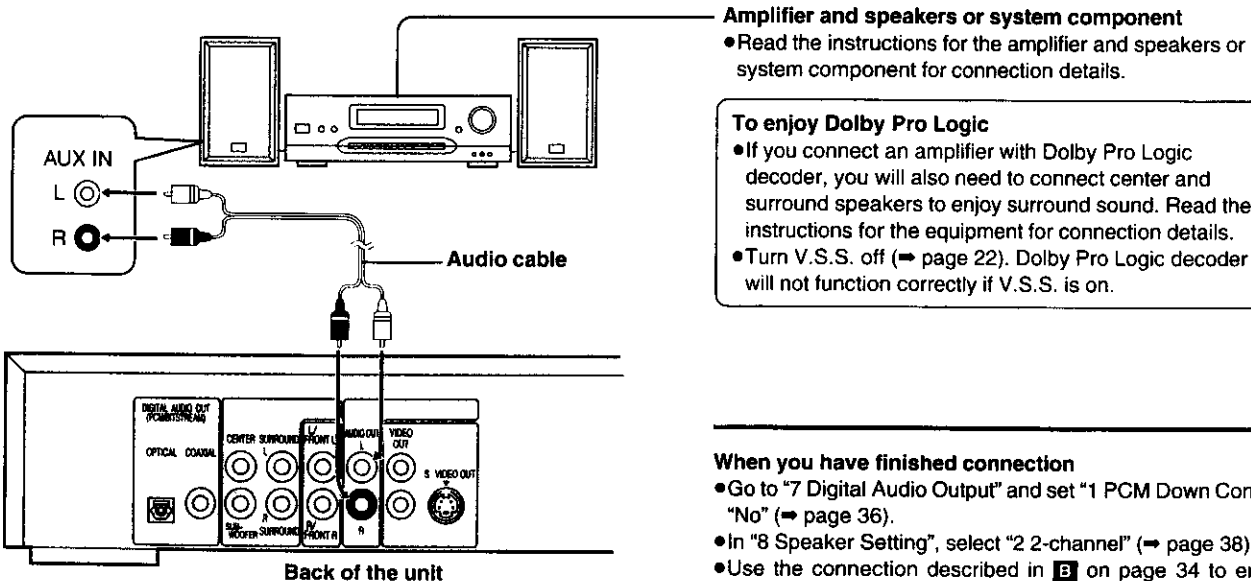

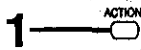
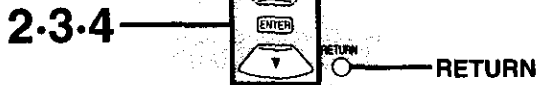

1

ACTION

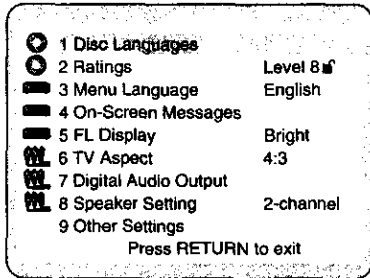

2

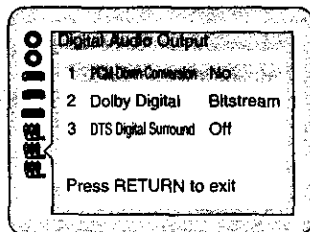
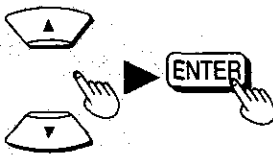

3

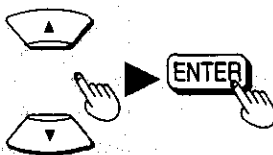

4

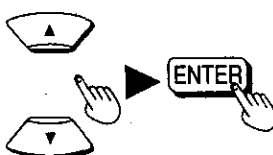

Selecting digital output

Select the digital output to be output from the optical or coaxial digital audio output terminal of the unit.

- 1 Press [ACTION] in the stop mode.
The initial settings screen is displayed.
- 2 Press the cursor buttons [▲, ▼] to select "7 Digital Audio Output" and press [ENTER].
- 3 Press the cursor buttons [▲, ▼] to select the item and press [ENTER].
 - 1 **PCM Down Conversion**
Select whether to output audio on DVD recorded in 96 kHz linear PCM as is (No) or to convert it to 48 kHz for output (Yes).
 - 2 **Dolby Digital**
To select the signal format (Bitstream or PCM) to be output from the optical or coaxial digital audio output terminal during play of DVDs recorded in Dolby Digital.
 - 3 **DTS Digital Surround**
To select whether DTS Digital Surround bitstream is output from the optical or coaxial digital audio output terminal or no digital audio is output during play of DVDs recorded in DTS Digital Surround.
- 4 Press the cursor buttons [▲, ▼] to select the setting and press [ENTER].

When "1 PCM Down Conversion" is selected

- 1 **No** (Factory preset)
No digital audio is output during play of DVDs recorded in 96 kHz linear PCM.
 - If the DVD is recorded in 48 kHz linear PCM, digital audio converted to 48 kHz/16 bit is output regardless of the setting.
 - Audio will be output using the original audio recording system if the DVD has not been copyright-protected.
- 2 **Yes***1
During play of DVDs recorded in 48 kHz or 96 kHz linear PCM, digital audio converted to 48 kHz/16 bit is output. (Digital output of PCM audio is restricted to 48 kHz/16 bit or below for copyright protection.)

When "2 Dolby Digital" is selected

- 1 **Bitstream***2 (Factory preset)
Dolby Digital bitstream (1ch–5.1ch) is output during play of DVDs recorded in Dolby Digital.
- 2 **PCM**
Digital audio converted to 48 kHz/16 bit PCM (2ch) is output during play of DVDs recorded in Dolby Digital.

When "3 DTS Digital Surround" is selected

- 1 **Off** (Factory preset)
No digital audio is output during play of DVDs recorded in DTS Digital Surround.
- 2 **Bitstream***2
DTS Digital Surround bitstream (1ch–5.1ch) is output during play of DVDs recorded in DTS Digital Surround.

The screen illustrated in step 2 is displayed.

To cancel during setup operation

Press [RETURN]. (The previous screen is displayed.)

To exit the initial settings screen

Press [ACTION] or [RETURN].

Recommended setting of "Digital Audio Output"

Adjust settings as shown in the table below depending on the kind of equipment that is connected to the optical or coaxial digital audio output terminal.

Type of equipment connected	Recommended setting		
	1 PCM Down Conversion	2 Dolby Digital	3 DTS Digital Surround
No equipment is connected	<u>No</u>	<u>Bitstream</u>	<u>Off</u>
Digital audio equipment (no decoder) (⇒ page 35)	Yes*1	PCM*2	<u>Off</u> *2
Dolby Digital decoder (⇒ page 34)	Yes*1	<u>Bitstream</u>	<u>Off</u>
DTS Digital Surround decoder (⇒ page 34)	Yes*1	PCM	Bitstream
Dolby Digital/DTS Digital Surround decoder (⇒ page 34)	Yes*1	<u>Bitstream</u>	Bitstream

• Underlined items are factory preset.

*1 If it is set to "Yes", the unit converts linear PCM to 48 kHz even during analog output.

Do the following if you wish to take advantage of high quality 96 kHz sound.

Select "No" and connect this unit's audio output terminal to an amplifier's audio input terminal with the audio/video cable (included) or an audio cable (not included).

*2 When connecting an amplifier (with an optical or coaxial digital input terminal) which does not contain a Dolby Digital or DTS Digital Surround decoder, be sure to select "PCM" at "2 Dolby Digital" and "Off" at "3 DTS Digital Surround". If "Bitstream" is selected, any attempt to play DVDs (or CDs encoded with DTS) may cause a high level of noise that can injure your ears and damage your speakers.

For your reference

- Dolby Digital is a digital sound compression technique developed by Dolby Laboratories. Supporting 5.1-channel surround sound, as well as stereo (2-channel) sound, this technique enables a large quantity of sound data to be efficiently recorded on a disc.
- DTS Digital Surround is a 5.1-channel surround sound system, which is widely used in movie theaters around the world. The separation between channels is good and provides a very real surround effect.
- PCM (pulse code modulation) is the usual digital method used for music CDs. DVDs have a greater volume so they use linear PCM, which has a higher sampling rate.
- Bitstream is a compressed digital audio signal. This signal can be decoded into different channels to produce, for instance, 5.1-channel surround sound.
- The digital audio output terminal (optical) converts electrical signals into optical signals and transfers them to an amplifier. These optical signals are immune to electrical interference, and they also have minimal effect on other equipment.

Manufactured under license from Dolby Laboratories. "Dolby", "Pro Logic" and the double-D symbol are trademarks of Dolby Laboratories. Confidential unpublished works. © 1992-1997 Dolby Laboratories. All rights reserved.

"DTS" and "DTS Digital Surround" are trademarks of Digital Theater Systems, Inc.

Speaker Setting

Here you can change the settings for the built-in decoder. These changes will have no effect if you connect the unit to other equipment through the digital audio output terminal (make the necessary changes on the other equipment).

Common procedures

- 1 Press [ACTION] in the stop mode. The initial settings screen is displayed.
- 2 Press the cursor buttons [▲, ▼] to select "8 Speaker Setting" and press [ENTER].
- 3 Press the cursor buttons [▲, ▼] to select the item and press [ENTER].

1 Multi-channel

If you have connected 3 or more speakers. (Proceed to step 4)

2 2-channel (Factory preset)

If you have connected 2 speakers or an amplifier with Dolby Pro Logic decoder. (You will return to the menu shown in step 1. Settings are not necessary.)

- 4 Change settings to suit your speakers and the listening position (→ page 39).

•Setting the size and presence of your speakers

Choose "Yes" for speakers you have connected. Sound will not be output if you choose "No".

•Delay time

Allows you to make up for differences in distance if you cannot place your speakers in the optimum position.

•Channel balance

Allows you to adjust the output level of the speakers to make up for differences in volume caused by different types of speaker or distance.

- 5 Press the cursor buttons [▲, ▼, ◀, ▶] to select "Exit" and press [ENTER].

The screen illustrated in step 2 is displayed.

To cancel during setup operation

Press [RETURN]. (The previous screen is displayed.)

To exit the initial settings screen

Press [ACTION] or [RETURN].

2.3.4.5 —  — RETURN

1 — 

1

ACTION

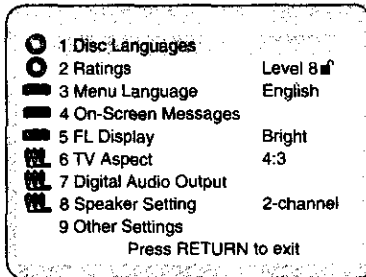

2

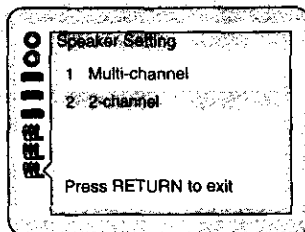
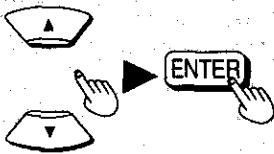

3

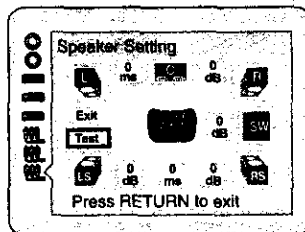
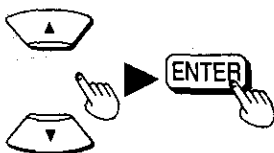

4

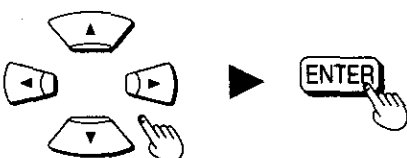

5

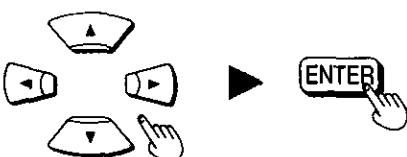

A Front (L) Large/Small Center Large/Small/No Front (R) Large/Small

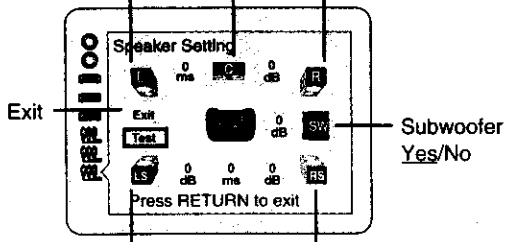

Surround (L) Large/Small/No Surround (R) Large/Small/No

• Underlined items are factory preset.

In case of surround speaker (L)



B

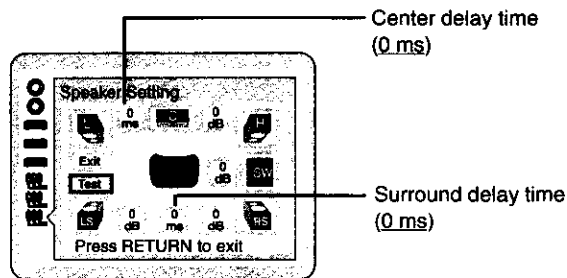

• Underlined items are factory preset.

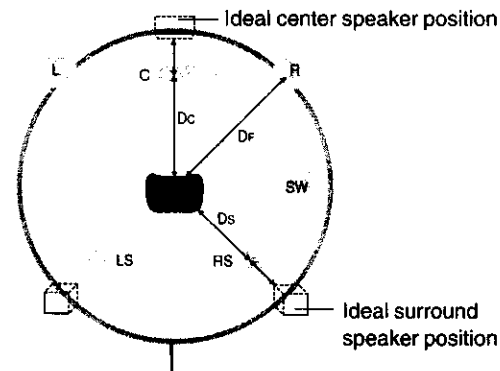

C

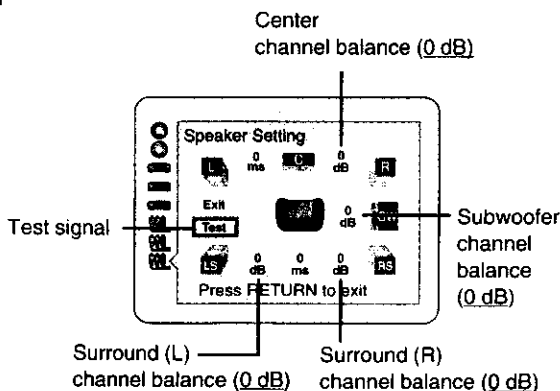

• Underlined items are factory preset.

A Setting the size and presence of your speakers

1. Press the cursor buttons [▲, ▼, ◀, ▶] to select the item and press [ENTER].
 2. Press the cursor buttons [▲, ▼] to select the setting and press [ENTER].
 - Large speaker icon
If the speaker supports low-frequency (under 100 Hz) reproduction.
 - Small speaker icon
If the speaker does not support low-frequency reproduction.
- If you do not connect a subwoofer, it is preferable to connect front speakers (L/R) capable of producing bass of less than 100 Hz.

B Delay time

DVD

1. Press the cursor buttons [▲, ▼, ◀, ▶] to select the item and press [ENTER].
2. Press the cursor buttons [▲, ▼] to adjust the delay time and press [ENTER].
 - Center speaker
Set delay time to "0 ms" (factory preset) if D_f is less than or equal to D_c .

If $D_f - D_c =$	then set to
approx. 50 cm (1 1/2 feet)	1.3 ms
approx. 100 cm (3 feet)	2.6 ms
approx. 150 cm (5 feet)	3.9 ms
approx. 200 cm (6 feet)	5.3 ms

• Surround speakers

Set delay time to "0 ms" (factory preset) if D_f and D_s are equal.

If $D_f - D_s =$	then set to
approx. 200 cm (6 feet)	5.3 ms
approx. 400 cm (12 feet)	10.6 ms
approx. 600 cm (18 feet)	15.9 ms

C Channel balance

1. Press the cursor buttons [▲, ▼, ◀, ▶] to select "Test" and press [ENTER].
A test signal is output from one speaker at a time, starting with the front left speaker and proceeding clockwise.

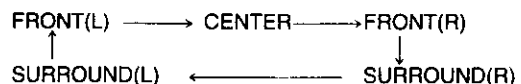

2. While listening to the test signal, press the cursor buttons [▲, ▼] to adjust the volume of the center and surround speakers so they are the same apparent volume as the front speakers. (The front speakers cannot be adjusted here.)
3. Press [ENTER]. (The test signals are stopped.)

Note

• No signal is output for the subwoofer. To adjust its volume, play something, then return to this screen to adjust to your taste.

Troubleshooting Guide

Before requesting service for this unit, check the chart below for a possible cause of the problem you are experiencing. Some simple checks or a minor adjustment on your part may eliminate the problem and restore proper operation.

If you are in doubt about some of the check points, or if the remedies indicated in the chart do not solve the problem, refer to the directory of Authorized Service Centers (enclosed with this unit) to locate a convenient service center, or consult your dealer for instructions.

For detailed instructions, contact an authorized servicer in the U.S.A. and Panasonic Canada Inc. Customer Care Centre in Canada. In the U.S.A., call 1-800-211-7262, e-mail consumerproducts@panasonic.com, or visit www.panasonic.com. In Canada, call 1-800-561-5505 or visit www.panasonic.ca

Reference pages are shown as black circled numbers ③.

Common Problems

<p>No power.</p> <p>The unit is automatically switched to the standby mode.</p> <p>Play fails to start even when [▶ PLAY] is pressed.</p> <p>Play starts but then stops immediately.</p> <p>No picture.</p> <p>No sound.</p> <p>Distorted sound.</p> <p>Picture distorted during rapid advance or rapid reverse.</p> <p>No key operation (by the main unit and/or the remote control) is effective.</p> <p>The picture shown on the television is not normal. (The sides of the picture are cut off or black bands appear at the top and bottom of the screen.)</p> <p>No on-screen display.</p> <p>On-Screen Menu Icons not displayed or only partially displayed on the TV screen.</p> <p>The language for the unit's menus and on-screen messages is different.</p> <p>No operations can be performed with the remote control.</p>	<p>Insert the AC power supply cord securely into the household AC outlet. ③</p> <p>To conserve power, the unit automatically switches to the standby mode after approx. 30 minutes elapse in the stop mode (Auto power-off function). Turn the power back to ON.</p> <p>Condensation has formed: Wait about 1 to 2 hours for it to evaporate.</p> <p>This unit cannot play discs other than DVD, Video CD and CD. ③</p> <p>DVDs with a region number other than "1" or "ALL" cannot be played. DVDs with multiple region numbers including "1" can be played. ③</p> <p>The disc may be dirty and may require cleaning. ⑦</p> <p>Ensure that the disc is installed with the label of the side to be played facing upwards. ①</p> <p>Ensure that the equipment is connected properly. ③ ④</p> <p>Ensure the television's video input setting (e.g., VCR 2) is correct.</p> <p>Ensure that the equipment is connected properly. ③ ④ ⑩-⑫</p> <p>Ensure that the input settings for the television and stereo system are correct.</p> <p>Adjust the master volume using the On-Screen Menu Icons for unit information. ⑫</p> <p>Turn V.S.S. off if it is on. ⑦ ⑫</p> <p>The picture will be somewhat distorted at times: This is normal.</p> <p>Some operations may be prohibited by the disc.</p> <p>Press [POWER ⏻/⏹] to switch the unit to the standby mode and then back to ON. Alternatively, press [POWER ⏻/⏹] to switch the unit to the standby mode, disconnect the AC power supply cord and then reconnect it. (The unit may not be operating properly due to lightning, static electricity or some other external factor.)</p> <p>Go to the initial settings menu "6 TV Aspect" and change the setting to suit your television. You may also need to change the screen mode on the television itself. ⑩ ⑪</p> <p>"Off" is selected for "1 On-Screen Messages" in "4 On-Screen Messages": Select "On". ⑫</p> <p>Change the position of the On-Screen Menu Icons using "2 Color and Position" in "4 On-Screen Messages" of the initial settings. ⑫</p> <p>Go to the initial settings menu "3 Menu Language" and change the language. ⑫</p> <p>To conserve power, the unit automatically switches to the standby mode after approx. 30 minutes elapse in the stop mode (Auto power-off function). Turn the power back to ON.</p> <p>Check the batteries are installed with the correct polarities (+ and -). ⑦</p> <p>The batteries are depleted: Replace them with new ones. ⑦</p> <p>Point the remote control at the remote control sensor and operate. ⑦</p> <p>Operate the remote control at a distance of not more than 7 m (23 feet) from the remote control sensor. ⑦</p> <p>Remove the obstacles between the remote control and remote control sensor. ⑦</p>
--	--

For your reference

DVD

<p>No subtitles.</p> <p>Alternative soundtrack (or subtitle) languages fail to be selected.</p> <p>Angle cannot be changed.</p> <p>Soundtrack and/or subtitle language is not the one selected at the initial settings.</p> <p>The disc's menu is displayed in French (example).</p> <p>Sound does not come from a speaker.</p> <p>You have forgotten your ratings password. Reset all the settings to Factory Preset.</p> <p>There are no vocals while playing Karaoke DVD.</p> <p>The vocals cannot be turned off.</p> <p>A menu is shown after playing each song on a Karaoke DVD.</p>	<p>Subtitles appear only with discs which contain them. Subtitles are cleared from the TV monitor. Display the subtitles. ① ②</p> <p>An alternative language is not selected with discs which do not contain more than one language. In the case of some discs, the alternative language cannot be selected by operating the [AUDIO] or [SUBTITLE]. Try selecting it from the disc's menu if one is available.</p> <p>This function is dependent on software availability. Even if a disc has a number of angles recorded, these angles may be recorded for specific scenes only (when "ANGLE" lights up on the unit's FL display). ①</p> <p>If the soundtrack and/or subtitle language does not exist on the disc, the language selected at the initial settings will not be seen/heard.</p> <p>The setup "3 Menus" of "1 Disc Languages" is set to French: Select English. ②</p> <p>Check the connections. ③ ④ ⑫-⑬</p> <p>If you have connected this unit to an amplifier through the audio output terminals, go to the initial settings menu "8 Speaker Setting" and change the settings to suit your speakers. Select "Yes" for all the speakers you have connected. ⑭</p> <p>This unit cannot decode DTS encoded discs. To enjoy DTS encoded discs, connect to an amplifier that has a DTS Digital Surround decoder. ⑮</p> <p>If you have connected this unit to an amplifier (with built-in decoder) through the digital audio output terminal, go to the initial settings menu "7 Digital Audio Output" and change the settings to "Bitstream" for "2 Dolby Digital" or/and "3 DTS Digital Surround". ⑯</p> <p>Sound will only come from the 2 front speakers if V.S.S. is on. Turn V.S.S. off. ⑰</p> <p>While stopped, press and hold [◀◀] and [▶▶] on the unit and then also press and hold [▲ OPEN/CLOSE] on the unit until "Initialized" disappears from the television (after approx. 3 seconds). All initial settings will return to the default values.</p> <p>When you have connected this unit to other equipment through the DIGITAL AUDIO OUT terminal, go to "7 Digital Audio Output" in the initial settings and change the setting for "2 Dolby Digital" to "PCM". ⑱</p> <p>You have selected an audio channel that includes a vocal channel. Read the disc's jacket to choose the correct channel. ⑲</p> <p>Most Karaoke DVDs are designed to do this. Some discs have an item in the menu that allows you to play all the songs.</p>
---	---

Video CD

<p>No menu play.</p>	<p>This function works only for Video CDs with playback control. ⑥</p>
-----------------------------	--

Self-diagnosis display function

When an error or trouble is detected during operation, a message appears in the FL display. When a message has appeared, check the details given below.

Message	Unit status	Remedy
CHECK THE DISC	Disc is dirty.	Wipe the disc clean. ⑦
<p>H□□</p> <p>□□ stands for a number.</p>	<p>Trouble is likely to have occurred. The number following "H" depends on the status of the unit.</p>	<p>Press [POWER ⏻/⏻] to switch the unit to the standby mode and then back to ON. Alternatively, press [POWER ⏻/⏻] to switch the unit to the standby mode, disconnect the AC power supply cord, and then reconnect it.</p>

• If the message fails to be cleared, even when remedial action is taken, ask a service technician to repair the unit.

Product Service

Do not attempt to remove the cover(s) or repair the unit yourself. Refer servicing to qualified personnel only.

Product Information

For product service, product information or assistance with product operation, refer to the servicer directory.

If you ship the product

Carefully pack and send it prepaid, adequately insured and preferably in the original carton. Attach a postage-affixed letter, detailing the complaint, to the outside of the carton. *DO NOT send the product to the Executive or Regional Sales offices. They are NOT equipped to make repairs.*

Servicenter List (US)

Panasonic

Technics

Quasar

*For Product Information, Operating Assistance, Literature Request, Dealer Locations, and all Customer Service inquiries please contact:
1-800-211-PANA (7262), Monday-Friday 9 am-9pm; Saturday-Sunday 9 am-7pm, EST.*

*Web Site: <http://www.panasonic.com>
You can purchase parts, accessories or locate your nearest servicenter by visiting our Web Site.*

Accessory Purchases:

1-800-332-5368 (Customer Orders Only)
Panasonic Services Company 20421 84th Avenue South, Kent, WA 98032
(6 am to 5 pm Monday-Friday; 6 am to 10:30 am Saturday; PST)
(Visa, MasterCard, Discover Card, American Express, Check)

Factory Servicenters Locations

CALIFORNIA

6550 Katella Avenue
Cypress, CA 90630

800 Dubuque Avenue
S. San Francisco
CA 94080

20201 Sherman Way
Suite 102
Canoga Park, CA 91306

3878 Ruffin Road
Suite A
San Diego, CA 92123

COLORADO

1640 South Abilene Street
Suite D
Aurora, CO 80012

FLORIDA

3700 North 29th Avenue
Suite 102
Hollywood, FL 33020

GEORGIA

8655 Roswell Road
Suite 100
Atlanta, GA 30350

ILLINOIS

9060 Golf Road
Niles, IL 60714

1703 North Randall Road
Elgin, IL 60123
(Pick-up/Drop-off only)

MARYLAND

62 Mountain Road
Glen Burnie, MD 21061

MASSACHUSETTS

60 Glacier Drive
Suite C
Westwood, MA 02090

MICHIGAN

37048 Van Dyke Avenue
Sterling Heights, MI 48312

MINNESOTA

7850-12th Avenue South
Airport Business Center
Bloomington, MN 55425

OHIO

2236 Waycross Road
Civic Center Plaza
Forest Park, OH 45240

PENNSYLVANIA

2221 Cabot Blvd. West
Suite B
Langhorne, PA 19047

TEXAS

13615 Welch Road
Suite 101
Farmers Branch
TX 75244

WASHINGTON

20425-84th Avenue South
Kent, WA 98032

HAWAII

99-859 Iwaiwa Street
Aiea, Hawaii 96701
Phone (808) 488-1996
Fax (808) 486-4369

For your reference

Service in Puerto Rico

*Matsushita Electric of Puerto Rico, Inc. Panasonic Sales Company/Factory Servicenter:
Ave. 65 de Infanteria, Km. 9.5, San Gabriel Industrial Park, Carolina, Puerto Rico 00985
Phone (787) 750-4300 Fax (787) 768-2910*

Specifications

Power requirements: AC 120 V, 60 Hz
Power consumption: 17 W
Dimensions: 430 (W)×273 (D)×82 (H) mm
[16¹⁵/₁₆" (W)×10³/₄" (D)×3¹/₄" (H)]
(excluding protrusions)
Mass: 2.9 kg (6.4 lb.)
Signal system: NTSC
Operating temperature range: +5 to +35 °C (+41 to +95 °F)
Operating humidity range: 5–90 % RH (no condensation)

Discs played:

(1) **DVD-Video disc:**

12 cm (5") single-sided, single-layer
12 cm (5") single-sided, dual-layer
12 cm (5") double-sided, single-layer
8 cm (3") single-sided, single-layer
8 cm (3") single-sided, dual-layer
8 cm (3") double-sided, single-layer

(2) **Compact disc (CD-DA, Video CD):**

12 cm (5") disc
8 cm (3") disc

Video output:

Output level: 1 Vp-p (75 Ω)
Output terminal: Pin jack (2 systems)

S video output:

Y output level: 1 Vp-p (75 Ω)
C output level: 0.286 Vp-p (75 Ω)
Output terminal: S terminal (1 system)

Component video output:

Y output level: 1 Vp-p (75 Ω)
P_B output level: 0.7 Vp-p (75 Ω)
P_R output level: 0.7 Vp-p (75 Ω)
Output terminal: Pin jack
(Y: green, P_B: blue, P_R: red)

Audio output:

Output level: 2 Vrms (1 kHz, 0 dB)
Output terminal: Pin jack
Mixed output (L/R): 1 system
5.1ch discrete output (5.1ch): 1 system

Audio signal output characteristics:

- (1) **Frequency response:**
●DVD (linear audio): 4 Hz–22 kHz (48 kHz sampling)
4 Hz–44 kHz (96 kHz sampling)
●CD audio: 4 Hz–20 kHz (EIAJ)
- (2) **S/N ratio:**
●CD audio: 115 dB (EIAJ)
- (3) **Dynamic range:**
●DVD (linear audio): 102 dB
●CD audio: 98 dB (EIAJ)
- (4) **Total harmonic distortion:**
●CD audio: 0.0025 % (EIAJ)

Digital audio output:

Optical digital output: Optical terminal
Coaxial digital output: Pin jack

Pickup: **Wave length:** 665 nm
Laser power: CLASS II

Power consumption in standby mode: approx. 2.0 W

Note

Specifications are subject to change without notice.
Mass and dimensions are approximate.

Apparatus Claims of U.S. Patent Nos. 4,631,603, 4,577,216, and 4,819,098, licensed for limited viewing uses only.

This product incorporates copyright protection technology that is protected by method claims of certain U.S. patents and other intellectual property rights owned by Macrovision Corporation and other rights owners. Use of this copyright protection technology must be authorized by Macrovision Corporation, and is intended for home and other limited viewing uses only unless otherwise authorized by Macrovision Corporation. Reverse engineering or disassembly is prohibited.

**Panasonic Consumer Electronics Company,
Division of Matsushita
Electric Corporation of America**
One Panasonic Way Secaucus,
New Jersey 07094
<http://www.panasonic.com>

**Panasonic Sales Company,
Division of Matsushita Electric of
Puerto Rico, Inc. ("PSC")**
Ave. 65 de Infantería, Km. 9.5
San Gabriel Industrial Park, Carolina,
Puerto Rico 00985

Panasonic Canada Inc.
5770 Ambler Drive
Mississauga, Ontario
L4W 2T3
www.panasonic.ca

En