

Owner's Manual

CRAFTSMAN®

DETAIL BISCUIT JOINER Double Insulated

Model No.
315.175500

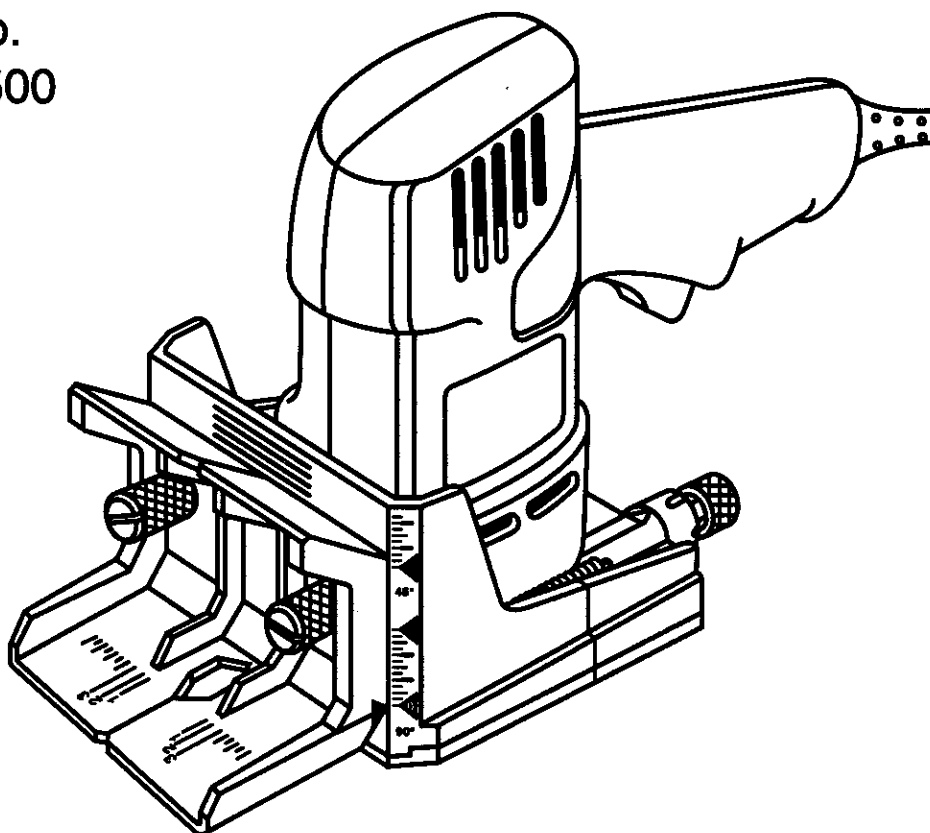

Save this manual for
future reference

▲ CAUTION: Read and follow all
Safety Rules and Operating
Instructions before first use of this
product.

Sears, Roebuck and Co., Hoffman Estates, IL 60179 USA



SAFETY

FEATURES

ADJUSTMENTS

OPERATION

MAINTENANCE

PARTS LIST

TYPICAL APPLICATIONS

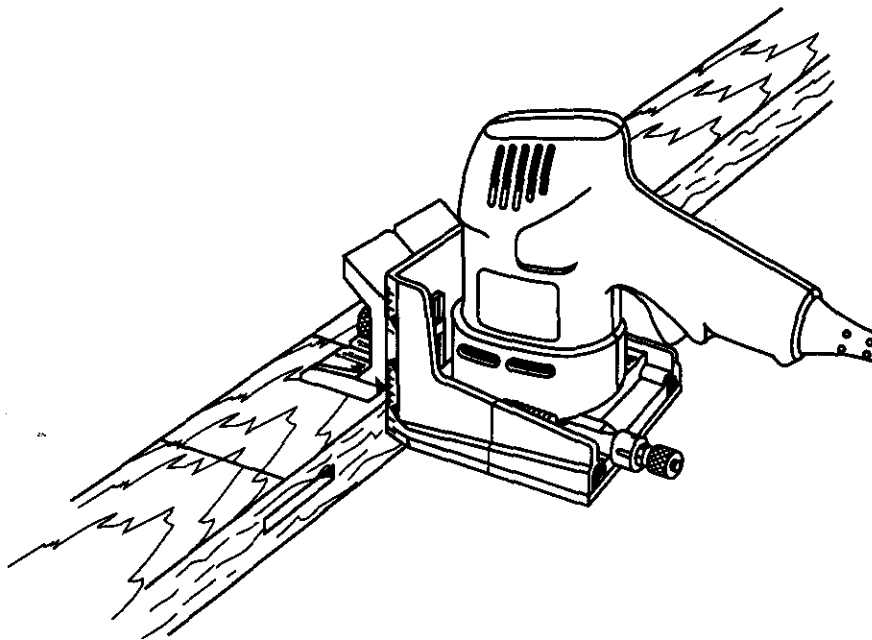

DETAIL BISCUIT JOINER 315.175500

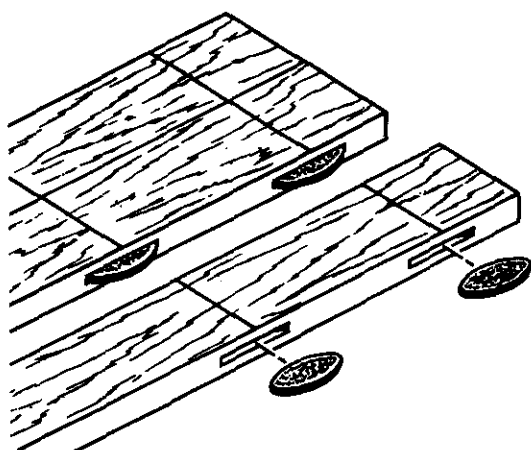

EDGE-TO-EDGE JOINTS

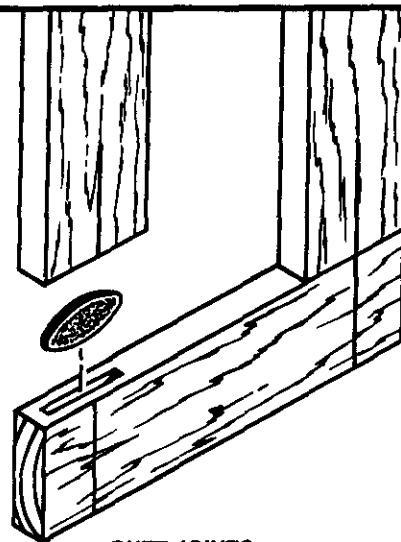

BUTT JOINTS

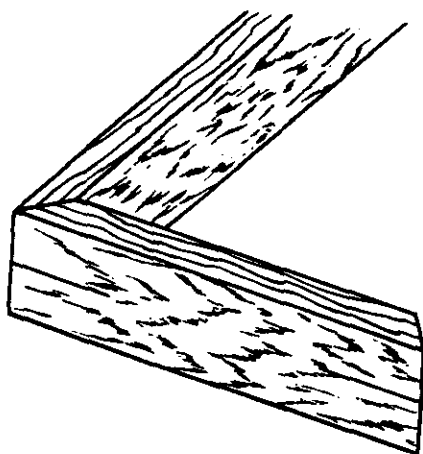

MITER JOINTS

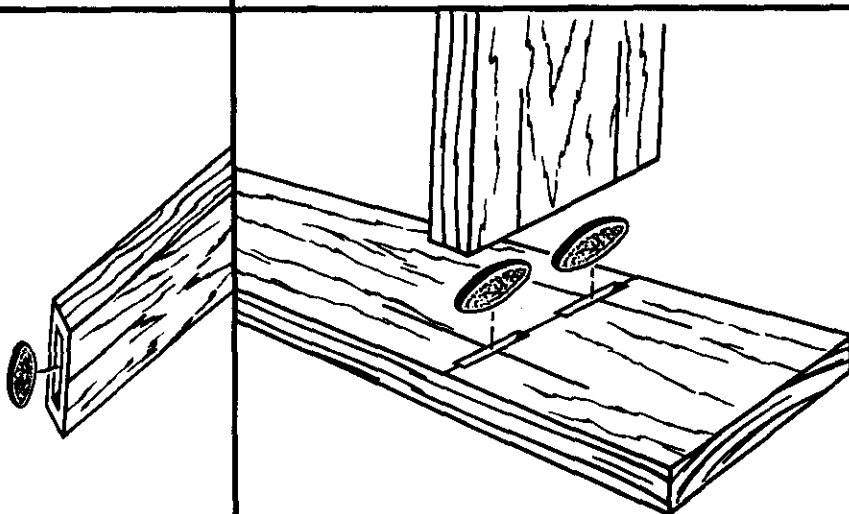

T-JOINT

TABLE OF CONTENTS

■ Typical Applications	2
■ Table Of Contents	3
■ Warranty and Introduction	3
■ Rules For Safe Operation	4-6
■ Product Specifications, Unpacking, and Accessories	7
■ Features	8-9
■ Adjustments	10-11
■ Operation	12-17
■ Maintenance	18-20
■ Troubleshooting	21
■ Exploded View and Repair Parts List	22-23
■ Parts Ordering / Service	24

WARRANTY

FULL ONE YEAR WARRANTY ON CRAFTSMAN DETAIL BISCUIT JOINER

If this **CRAFTSMAN** Biscuit Joiner fails to give complete satisfaction within one year from the date of purchase, **RETURN IT TO THE NEAREST SEARS STORE IN THE UNITED STATES**, and Sears will repair it, free of charge.

If this **CRAFTSMAN** Biscuit Joiner is used for commercial or rental purposes, this warranty applies for only 90 days from the date of purchase.

This warranty gives you specific legal rights, and you may also have other rights which vary from state to state.

Sears, Roebuck and Co., Dept. 817WA, Hoffman Estates, IL 60179

INTRODUCTION

Your Biscuit Joiner has many features for making cutting operations more pleasant and enjoyable. Safety, performance and dependability have been given top priority in the design of this Biscuit Joiner, making it easy to maintain and operate.

Spline joinery is one of the strongest methods of joinery used in woodworking. When glue is properly applied to a spline and to the joint area of the wood pieces being connected, a large surface area receives the adhesion properties of the glue. This forms a very strong joint.

Traditional spline joinery requires cutting slots with a router or table saw. Small, thin strips of wood must then be cut to fit inside the slots and act as splines.

Newer methods of spline joinery use a plate or biscuit joiner to cut precise mating oval slots in adjoining boards. Your new Biscuit Joiner is a fast, simple, and accurate plunge cutting tool that can be used for this purpose. It can be used to cut slots in hardwood, softwood, plywood, particle board, and other pressed woods.



CAUTION: Carefully read through this entire owner's manual before using your new Biscuit Joiner. Pay close attention to the Rules For Safe Operation, Warnings and Cautions. If you use your Biscuit Joiner properly and only for what it is intended, you will enjoy years of safe, reliable service.

Football shaped wafers, called biscuits, are then placed inside the slots with glue and used to help line up adjoining surfaces. When a water based glue is used, the biscuits swell in the joint, making an extremely strong and firm bond. White glue, yellow glue, carpenters glue, hide glue, and aliphatic resin glue are examples of water based glues.

This bonding technique has traditionally been limited to making edge-to-edge joints. However, with the use of your new Biscuit Joiner, biscuits can now be easily used to connect butt, miter, and T-joints. Biscuit joining can be as strong as mortise and tenon, tongue and groove, standard spline, and doweled joints. In most cases the material around the biscuit will break before the biscuit itself will break. A greater surface area is exposed to glue in a biscuit joint, making the seams stronger.

RULES FOR SAFE OPERATION

The purpose of safety symbols is to attract your attention to possible dangers. The safety symbols, and the explanations with them, deserve your careful attention and understanding. The safety warnings do not by themselves eliminate any danger. The instructions or warnings they give are not substitutes for proper accident prevention measures.

SYMBOL MEANING



SAFETY ALERT SYMBOL: Indicates caution or warning. May be used in conjunction with other symbols or pictographs.



DANGER: Failure to obey a safety warning will result in serious injury to yourself or to others. Always follow the safety precautions to reduce the risk of fire, electric shock and personal injury.



WARNING: Failure to obey a safety warning can result in serious injury to yourself or to others. Always follow the safety precautions to reduce the risk of fire, electric shock and personal injury.



CAUTION: Failure to obey a safety warning may result in property damage or personal injury to yourself or to others. Always follow the safety precautions to reduce the risk of fire, electric shock and personal injury.

NOTE: Advises you of information or instructions vital to the operation or maintenance of the equipment.

DOUBLE INSULATION

Double insulation is a concept in safety, in electric power tools, which eliminates the need for the usual three-wire grounded power cord. All exposed metal parts are isolated from internal metal motor components with protecting insulation. Double insulated tools do not need to be grounded.

 **WARNING:** Do not attempt to operate this tool until you have read thoroughly and understand completely all instructions, safety rules, etc. contained in this manual. Failure to comply can result in accidents involving fire, electric shock, or serious personal injury. Save owner's manual and review frequently for continuing safe operation, and instructing others who may use this tool.

READ ALL INSTRUCTIONS

- **KNOW YOUR POWER TOOL.** Read owner's manual carefully. Learn its applications and limitations as well as the specific potential hazards related to this tool.
- **GUARD AGAINST ELECTRICAL SHOCK BY PREVENTING BODY CONTACT WITH GROUNDED SURFACES.** For example; pipes, radiators, ranges, refrigerator enclosures.
- **KEEP GUARDS IN PLACE AND IN WORKING ORDER.**

IMPORTANT

Servicing of a tool with double insulation requires extreme care and knowledge of the system and should be performed only by a qualified service technician. For service we suggest you return the tool to your nearest Sears Store for repair. Always use original factory replacement parts when servicing.

- **KEEP WORK AREA CLEAN.** Cluttered areas and benches invite accidents.
- **AVOID DANGEROUS ENVIRONMENT.** Don't use power tools in damp or wet locations or expose to rain. Keep work area well lit.
- **KEEP CHILDREN AND VISITORS AWAY.** All visitors should wear safety glasses and be kept a safe distance from work area. Do not let visitors contact tool or extension cord.
- **STORE IDLE TOOLS.** When not in use, tools should be stored in a dry and high or locked-up place – out of the reach of children.
- **DON'T FORCE TOOL.** It will do the job better and safer at the rate for which it was designed.
- **USE RIGHT TOOL.** Don't force small tool or attachment to do the job of a heavy duty tool. Don't use tool for purpose not intended – for example – A circular saw should never be used for cutting tree limbs or logs.

RULES FOR SAFE OPERATION (Continued)

- **WEAR PROPER APPAREL.** Do not wear loose clothing or jewelry that can get caught in tool's moving parts and cause personal injury. Rubber gloves and nonskid footwear are recommended when working outdoors. Wear protective hair covering to contain long hair and keep it from being drawn into nearby air vents.
 - **ALWAYS WEAR SAFETY GLASSES.** Everyday eyeglasses have only impact-resistant lenses; they are **not** safety glasses.
 - **PROTECT YOUR LUNGS.** Wear a face or dust mask if the cutting operation is dusty.
 - **PROTECT YOUR HEARING.** Wear hearing protection during extended periods of operation.
 - **DON'T ABUSE CORD.** Never carry tool by cord or yank it to disconnect from receptacle. Keep cord from heat, oil, and sharp edges.
 - **SECURE WORK.** Use clamps or a vise to hold work. It's safer than using your hand and it frees both hands to operate tool.
 - **DON'T OVERREACH.** Keep proper footing and balance at all times. Do not use on a ladder or unstable support. Secure tools when working at elevated positions.
 - **MAINTAIN TOOLS WITH CARE.** Keep tools sharp and clean for best and safest performance. Follow instructions for lubricating and changing accessories.
 - **DISCONNECT TOOLS.** When not in use, before servicing, or when changing attachments, blades, bits, cutters, etc., all tools should be disconnected from power supply.
 - **REMOVE ADJUSTING KEYS AND WRENCHES.** Form habit of checking to see that keys and adjusting wrenches are removed from tool before turning it on.
 - **AVOID ACCIDENTAL STARTING.** Don't carry plugged-in tool with finger on switch. Be sure switch is off when plugging in.
 - **MAKE SURE YOUR EXTENSION CORD IS IN GOOD CONDITION.** When using an extension cord, be sure to use one heavy enough to carry the current your product will draw. An undersized cord will cause a drop in line voltage resulting in loss of power and overheating. A wire gage size (A.W.G.) of at least 16 is recommended for an extension cord 100 feet or less in length. A cord exceeding 100 feet is not recommended. If in doubt, use the next heavier gage. The smaller the gage number, the heavier the cord.
 - **OUTDOOR USE EXTENSION CORDS.** When tool is used outdoors, use only extension cords suitable for use outdoors. Outdoor approved cords are marked with the suffix W-A, for example - SJTW-A or SJOW-A.
 - **KEEP BLADES CLEAN AND SHARP.** Sharp blades minimize stalling and kickback.
 - **KEEP HANDS AWAY FROM CUTTING AREA.** Keep hands away from blades. Do not reach underneath work while blade is rotating. Do not attempt to remove cut material when blade is moving.
-  **WARNING:** Blades coast after turn-off.
- **NEVER USE IN AN EXPLOSIVE ATMOSPHERE.** Normal sparking of the motor could ignite fumes.
 - **INSPECT TOOL CORDS PERIODICALLY** and if damaged, have repaired by authorized service facility. Stay constantly aware of cord location and keep it well away from the rotating blade.
 - **INSPECT EXTENSION CORDS PERIODICALLY** and replace if damaged.
 - **KEEP HANDLES DRY, CLEAN, AND FREE FROM OIL AND GREASE.** Always use a clean cloth when cleaning. Never use brake fluids, gasoline, petroleum-based products, or any strong solvents to clean your tool.
 - **STAY ALERT AND EXERCISE CONTROL.** Watch what you are doing and use common sense. Do not operate tool when you are tired. Do not rush.
 - **CHECK DAMAGED PARTS.** Before further use of the tool, a guard or other part that is damaged should be carefully checked to determine that it will operate properly and perform its intended function. Check for alignment of moving parts, binding of moving parts, breakage of parts, mounting and any other conditions that may affect its operation. A guard or other part that is damaged should be properly repaired or replaced by an authorized service center.
 - **DO NOT USE TOOL IF SWITCH DOES NOT TURN IT ON AND OFF.** Have defective switches replaced by an authorized service center.
 - **GUARD AGAINST KICKBACK.** Kickback occurs when the saw stalls rapidly and is driven back towards the operator. Release switch immediately if blade binds or saw stalls.

RULES FOR SAFE OPERATION (Continued)

- **USE ONLY 1-1/2 in. (38 mm) DIAMETER SPECIFIED BLADES.** Do not use blades with incorrect size holes. never use blade washers or bolts that are defective, incorrect, or not specified.
- **AVOID CUTTING NAILS.** Inspect for and remove all nails from lumber before cutting.
- **NEVER** touch the blade or other moving parts during use.
- **NEVER** start a tool when its moving component is in contact with the workpiece.
- **NEVER** lay a tool down before its moving parts have come to a complete stop.
- **DO NOT** operate this tool while under the influence of drugs, alcohol, or any medication.
- **POLARIZED PLUGS.** To reduce the risk of electric shock, this tool has a polarized plug (one blade is wider than the other). This plug will fit in a polarized outlet only one way. If the plug does not fit fully in the outlet, reverse the plug. If it still does not fit, contact a qualified electrician to install the proper outlet. Do not change the plug in any way.

- **WHEN SERVICING USE ONLY IDENTICAL CRAFTSMAN REPLACEMENT PARTS.**
- **SAVE THESE INSTRUCTIONS.** Refer to them frequently and use them to instruct others who may use this tool. If you loan someone this tool, loan them these instructions also.

⚠ WARNING: Some dust created by power sanding, sawing, grinding, drilling, and other construction activities contains chemicals known to cause cancer, birth defects or other reproductive harm. Some examples of these chemicals are:

- lead from lead-based paints,
- crystalline silica from bricks and cement and other masonry products, and
- arsenic and chromium from chemically-treated lumber.

Your risk from these exposures varies, depending on how often you do this type of work. To reduce your exposure to these chemicals: work in a well ventilated area, and work with approved safety equipment, such as those dust masks that are specially designed to filter out microscopic particles.

⚠ Look for this symbol to point out important safety precautions. It means attention!!! Your safety is involved.

⚠ WARNING:



The operation of any Biscuit Joiner can result in foreign objects being thrown into your eyes, which can result in severe eye damage. Before beginning power tool operation, always wear safety goggles or safety glasses with side shields and a full face shield when needed. We recommend Wide Vision Safety Mask for use over eyeglasses or standard safety glasses with side shields, available at Sears Retail Stores.

SAVE THESE INSTRUCTIONS

PRODUCT SPECIFICATIONS

No Load Speed	19,000 RPM	Fence Angles	45° and 90°
Rating	120 volts, 60 Hz, AC	Fence Height Adjustment	
Input	3.5 Amperes	With Fence Angle Set On 90°	0 - 3/4 in.
Depth Of Cut		With Fence Set On 45°	5/16 in. - 13/16 in.
With Micro Depth Of Cut Adjustment	0 - 9/32 in.	Net Weight	3.625 lbs.

UNPACKING

Your Biscuit Joiner has been shipped completely assembled and ready for use. Inspect it carefully to make sure no breakage or damage has occurred during shipping. If any parts are damaged or missing, contact your nearest Sears Retail Store to obtain replacement parts before attempting to operate Biscuit Joiner.



WARNING: If any parts are missing, do not operate this tool until the missing parts are replaced. Failure to do so could result in possible serious personal injury.

ACCESSORIES

The following recommended accessories are currently available at Sears Retail Stores.

- R1 Biscuit Pack 7/32 in. x 5/8 in.
- R2 Biscuit Pack 9/32 in. x 3/4 in.
- R3 Biscuit Pack 1/2 in. x 1 in.



WARNING: The use of attachments or accessories not listed might be hazardous.

FEATURES

Your Detail Biscuit Joiner has been designed for making fast, accurate, and simple plunge cuts in wood, etc. so that biscuits can be used to join two or more boards together. When used properly and only for what it is intended, this versatile tool will give you years of trouble-free performance. It is professionally engineered, but its ease of operation allows the amateur to produce beautiful and precise work.

SWITCH

To turn your Biscuit Joiner **ON**, depress the switch trigger. Release switch trigger to turn your Biscuit Joiner **OFF**.

MOTOR

Your Biscuit Joiner has a powerful motor with sufficient power to handle tough cutting jobs. It develops a no load speed of 19,000 RPM.

BLADE

Your Biscuit Joiner has a 1-1/2 in. (38 mm) 6 tooth blade for cutting biscuit slots.

BISCUITS

See Figure 1.

Biscuits are available in three standard sizes:

- R1 (7/32 in. x 5/8 in.)
- R2 (9/32 in. x 3/4 in.)
- R3 (1/2 in. x 1 in.)

Note: Store biscuits in a dry place because they swell rapidly upon contact with water-based woodworking glues.

R1 = 7/32 in. x 5/8 in.



R2 = 9/32 in. x 3/4 in.



R3 = 1/2 in. x 1 in.



Fig. 1

REVERSIBLE FENCE FOR 45° AND 90° CUTS

Your Biscuit Joiner has a reversible fence. By loosening the height adjustment knobs, the fence can be removed through key hole slots. Once removed, it can be rotated 180° changing the angle of cut from 90° to 45° or vice versa. The height of the fence at 90° can be set between 0 to 3/4 in. from the center of the blade. The height of the fence at 45° can be set between 5/16 in. to 13/16 in. from the center of the blade.

The fence should always be used to guide and balance your Biscuit Joiner, providing ease of operation and maintaining safe control.

NONSKID BACKING PAD

The fence on your Biscuit Joiner is padded with a nonskid backing pad to hold it stationary against the workpiece. It helps prevent skidding when making cuts. It also prevents marring of the workpiece from Biscuit Joiner when cutting.

INDICATOR MARKS

Centerline and line of cut indicator marks have been provided on your Biscuit Joiner. See Figure 2.

APPLICATIONS

(Use only for the purpose listed below)

- Cutting precise mating oval slots in hardwood, softwood, plywood, particle board, etc. for spline joinery applications.

DEPTH ADJUSTMENT KNOB

A spring loaded depth adjustment knob makes it possible to make proper settings for three standard size biscuits. Fine adjustments to the cutting depth can be made with a knurled adjustment knob and jam nut located behind the depth adjustment knob. Once the correct depth setting has been made for one biscuit size, the other two depth settings will be automatically set.

- ⚠ **WARNING:** Your Detail Biscuit Joiner should never be connected to power supply when you are assembling parts, making adjustments, assembling or removing blades, cleaning or when not in use. Disconnecting your Detail Biscuit Joiner will prevent accidental starting that could cause serious personal injury.

FEATURES

KNOW YOUR DETAIL BISCUIT JOINER

See Figure 2.

Before attempting to use any tool familiarize yourself with all operating features and safety requirements.

ELECTRICAL CONNECTION

Your Biscuit Joiner has a precision built electric motor. It should be connected to a **power supply that is 120 volts, 60 Hz, AC only (normal household current)**. Do not operate this tool on direct current (DC). A substantial voltage drop will cause a loss of power and the motor will overheat. If your Biscuit Joiner does not operate when plugged into an outlet, double-check the power supply.

⚠ WARNING: Do not allow familiarity with tools to make you careless. Remember that a careless fraction of a second is sufficient to inflict severe injury.

⚠ WARNING: Do not attempt to modify this tool or create accessories not recommended for use with this tool. Any such alteration or modification is misuse and could result in a hazardous condition leading to possible serious personal injury.

FEATURES

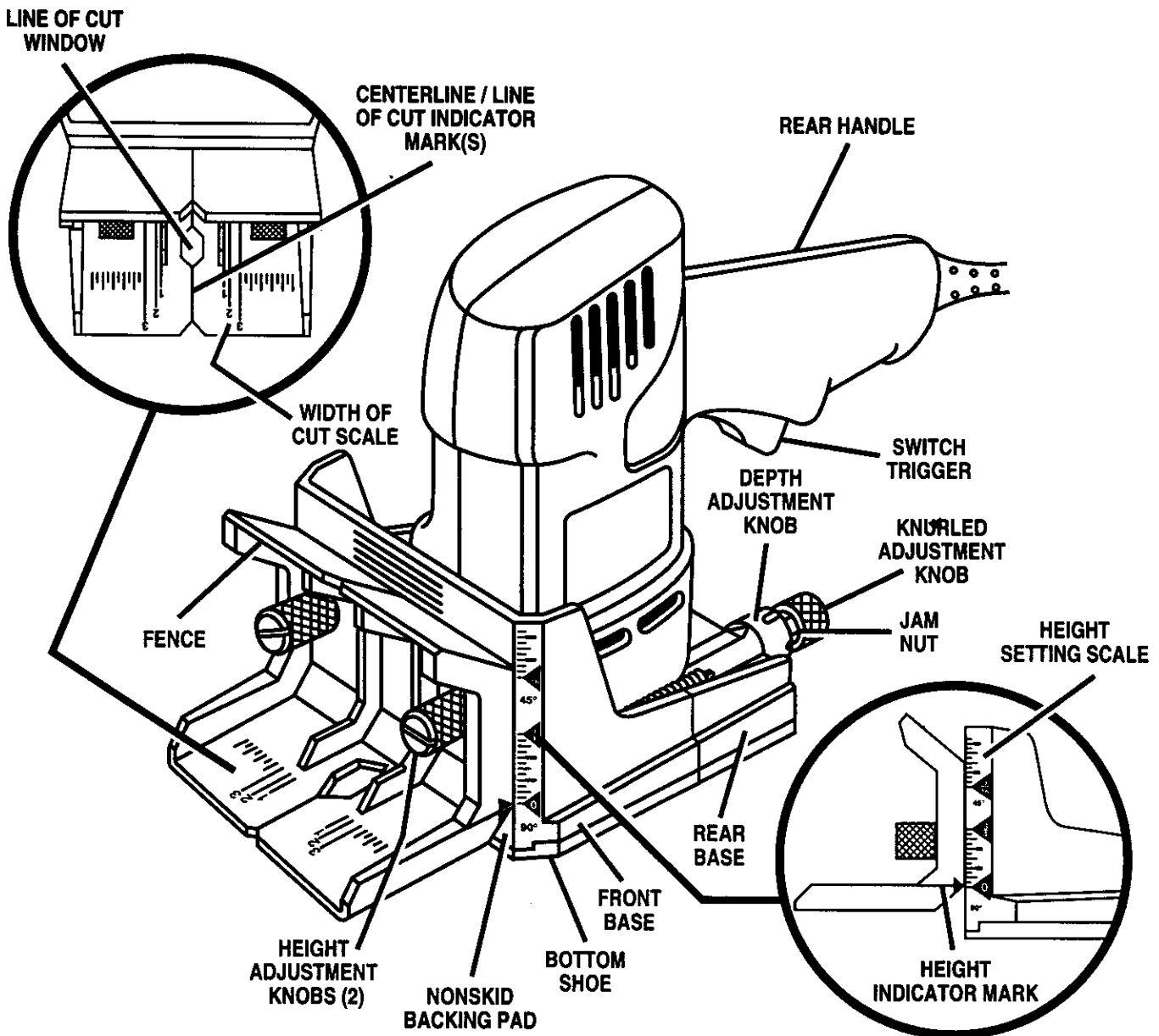

Fig. 2

ADJUSTMENTS

DEPTH OF CUT ADJUSTMENTS

Your Biscuit Joiner can be adjusted to three standard cutting depths to accommodate three standard size biscuits — R1, R2, and R3. Adjustments are made by engaging slots on depth adjustment knob with tabs on rear base. For example, when using a R1 size biscuit, rotate the depth adjustment knob until the slot marked 1 aligns with the depth indicator mark on the rear base. When using a R2 size biscuit, rotate the depth adjustment knob until the slot marked 2 aligns with the depth indicator mark on the rear base, and when using a R3 size biscuit rotate the depth adjustment knob until the slot marked 3 aligns with the depth indicator mark on the rear base. See *Figure 3*.

TO SET DEPTH ADJUSTMENT KNOB

- Unplug your Detail Biscuit Joiner.

⚠ WARNING: Failure to unplug Biscuit Joiner could result in accidental starting causing possible serious personal injury.

- Pull knurled adjustment knob and jam nut in the direction of the arrow shown in figure 3.

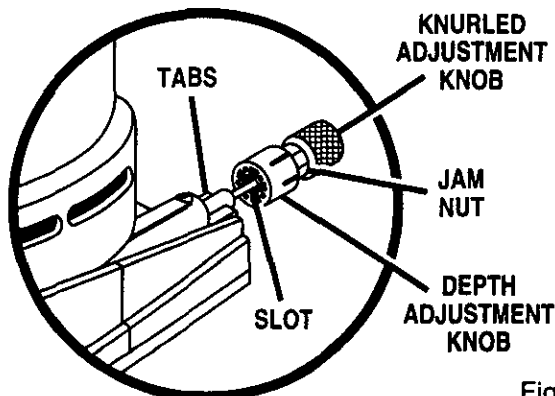
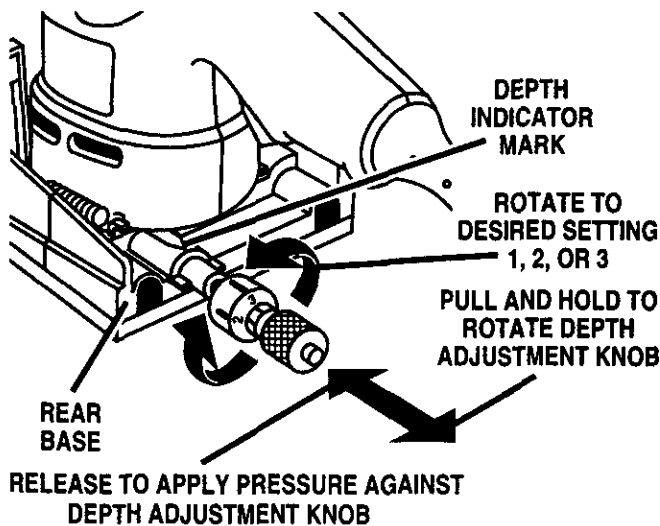

Fig. 3

Note: Knob and jam nut are spring loaded, therefore pulling them in the direction of the arrow shown puts pressure on the spring and releases pressure from the depth adjustment knob.

- Rotate depth adjustment knob until desired slot setting aligns with tabs on rear base — 1, 2, or 3.
- Next release knurled adjustment knob and jam nut applying pressure from spring on depth adjustment knob.

Make a test cut in a scrap piece of wood. Fit the correct size biscuit into biscuit slot. If biscuit slot is too deep or too shallow, fine adjustments to the depth setting can be made by loosening knurled adjustment knob and making fine adjustments with the jam nut. Turning jam nut forward will cut shallow biscuit slots. Turning jam nut backwards will cut deeper biscuit slots. The biscuit slot should be deep enough to allow slightly more than one-half of the biscuit into the slot. This extra room allows for proper alignment of the wood being joined.

TO MAKE FINE ADJUSTMENTS

See *Figure 4*.

- Unplug your Detail Biscuit Joiner.

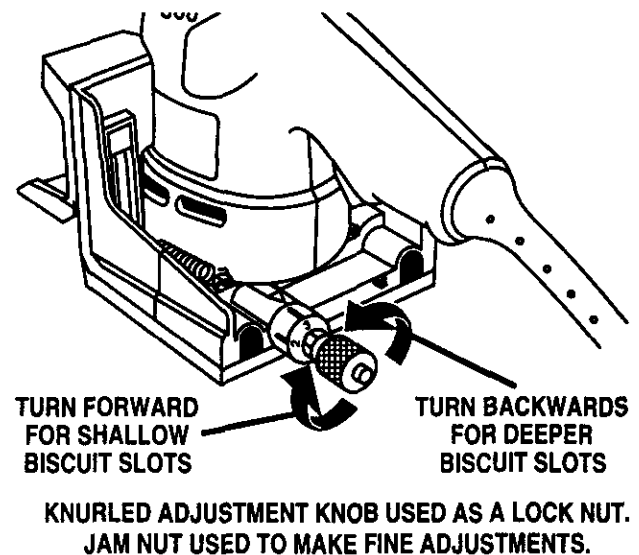

Fig. 4

- Loosen knurled adjustment knob. This knob is used as a lock nut only. Loosen by twisting it in the opposite direction away from jam nut.
- Turn jam nut forward (clockwise) for a more shallow cut, or backwards (counterclockwise) for a deeper cut.
- Once desired depth of cut is reached, hold jam nut so that it will not move out of adjustment. Next, tighten knurled adjustment knob against jam nut.
- Recheck depth setting by making a test cut in a scrap piece of wood. Also periodically check depth setting for accuracy. See *Figure 4*.

ADJUSTMENTS

FENCE HEIGHT ADJUSTMENT

See Figure 5.

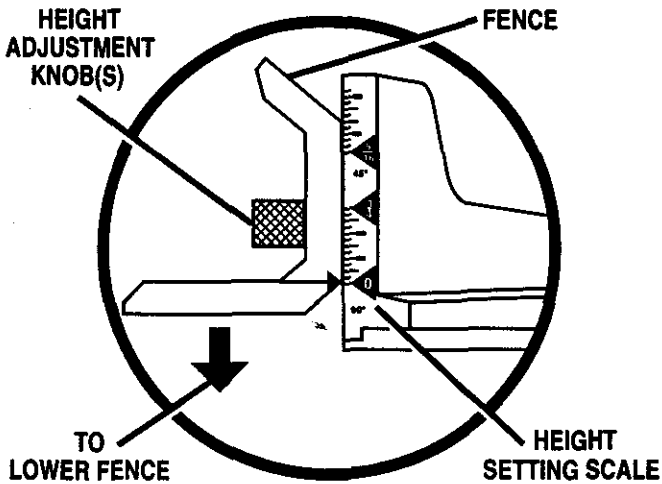

Fig. 5

The fence on your Biscuit Joiner can be moved up and down to adjust the position of the blade in relation to the top of the workpiece. A scale on both sides of the front base indicates height settings for both 45° and 90° angles. The fence and height indicator mark can be positioned from 5/16 in. to 13/16 in. from the center of the blade for 45° angles. It can be positioned from 0 to 3/4 in. from the center of the blade for 90° angles. Scale marks are in increments of 1/16 in.

TO ADJUST HEIGHT SETTING

See Figure 5.

- Unplug your Detail Biscuit Joiner.

WARNING: Failure to unplug your Detail Biscuit Joiner could result in accidental starting causing possible serious personal injury.

- Loosen the two height adjustment knobs.
- Pull the fence forward and slide it up or down until the height indicator mark is aligned with the desired dimension on the scale.

Note: Slots in the front base align with a tab on the backside of the fence. See Figure 6. This alignment keeps the fence square at each height setting.

- Tighten height adjustment knobs securely.

FENCE ROTATION/ANGLE ADJUSTMENT

See Figure 6.

The fence on your Biscuit Joiner can be rotated 180° and set at either 45° or 90° angles.

TO ROTATE FENCE/CHANGE ANGLE SETTING

See Figure 6.

- Unplug your Detail Biscuit Joiner.

WARNING: Failure to unplug your Detail Biscuit Joiner could result in accidental starting causing possible serious personal injury.

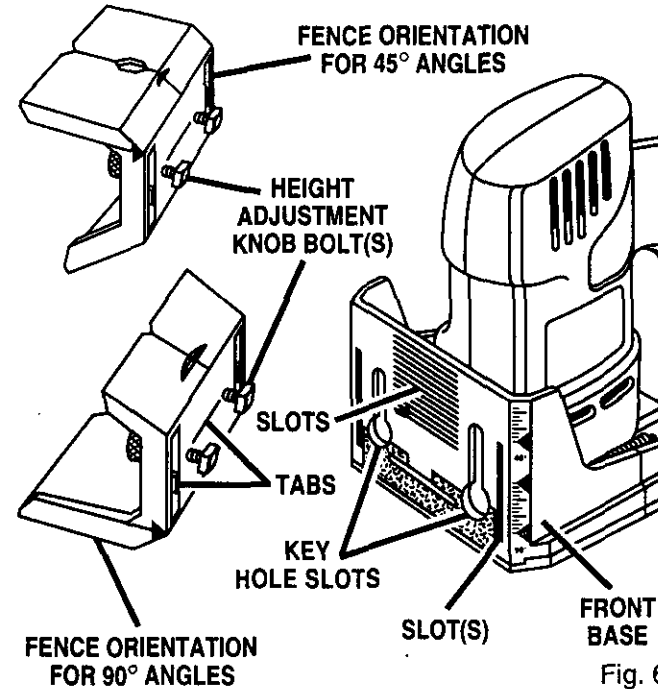
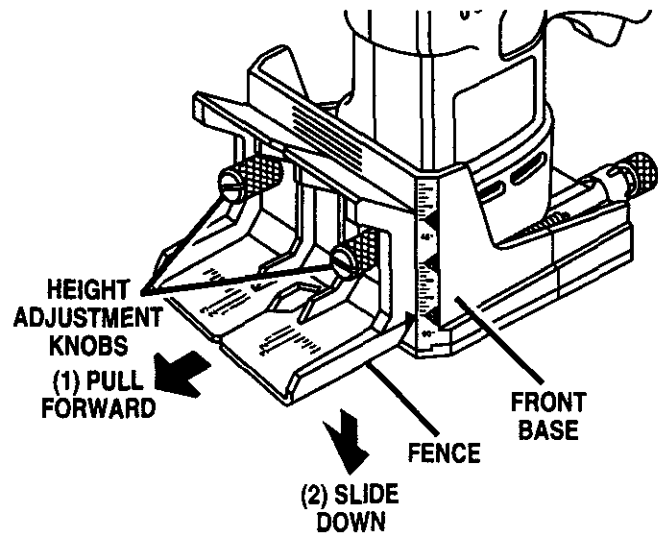

Fig. 6

- Loosen the two height adjustment knobs.
- Pull the fence forward and slide it down the front base until it can be removed through the key hole slots.
- Rotate the fence 180°.
- Reinstall the fence on the front base. Place height adjustment knob bolts in key hole slots and align bolt heads with the slots on back of front base.
- Slide fence up the front base to desired depth of cut.
- Tighten height adjustment knobs securely. See Figure 6.

ADJUSTMENTS

OPERATION

⚠ WARNING: Always wear safety goggles or safety glasses with side shields when operating tools. Failure to do so could result in objects being thrown into your eyes, resulting in possible serious injury.

A variety of spline joints can be made using your Biscuit Joiner. The number and size biscuits needed for each joint depends on the thickness of the wood and the length of the joint. In general, the small R1 biscuits should be used for miter cuts in small, thin materials. The larger biscuits should be used for edge-to-edge joinery.

When joining thick materials, stack two biscuits, one above the other. For example, joining 2 in. x 4 in. dressed lumber. See Figure 9. When joining even thicker materials, use additional biscuits, stacked above each other.

When making edge-to-edge joints the more biscuits you use, the stronger the joint will be.

The following sections illustrate how to make various spline joints using your Biscuit Joiner.

EDGE-TO-EDGE JOINTS

See Figures 7 and 8.

Edge-to-edge joinery is one of the most basic and easiest joints to construct. In general, two basic adjustments have to be made for all Biscuit Joinery applications. One is the depth of cut and the other is the location of the cut.

HOW TO MAKE EDGE-TO-EDGE JOINTS

- Unplug your Detail Biscuit Joiner.
- Prepare the workpieces by laying them side by side on a workbench in the order in which they will be assembled.
- Using a square, determine the location of each biscuit spline joint and mark the center of each joint by drawing a line across each workpiece. Mark edges 1 in. from the ends of workpieces. The joint will be stronger if you use multiple biscuits placed close together.
- Set fence angle at 90°.
- Loosen height adjustment knobs, then pull and slide the fence up or down until the indicator point is aligned with the desired dimension on the scale. **Remember:** The scale indicates the height of the fence from the center of blade.
- Tighten height adjustment knobs securely.
- Select the correct depth of cut setting to match the biscuit size you are planning to use. We suggest that you make a test cut in a scrap piece of wood from the same workpiece if possible.
- Clamp workpiece securely so it will not move during the cut.

- Plug your Biscuit Joiner into power supply and prepare to make your first cut. Grasp and hold your Biscuit Joiner securely.
- Place the fence against the board and align the indicator marks on the fence with the centerline mark(s) on the board. See Figure 7.

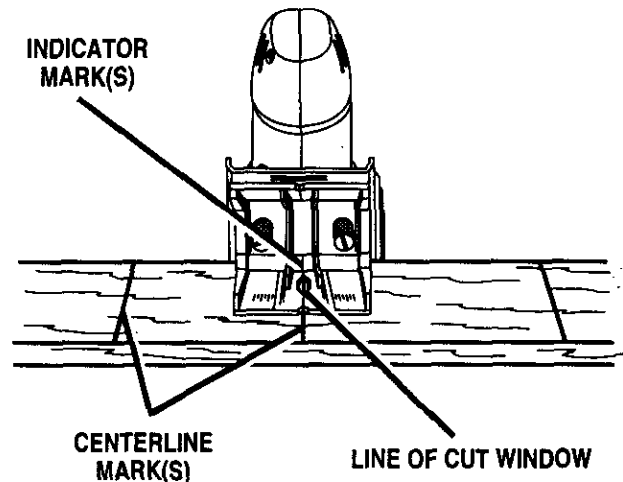

TOP VIEW OF DETAIL BISCUIT JOINER Fig. 7

- Depress the switch trigger and let the motor build to its maximum speed, then gradually push Biscuit Joiner forward to extend the blade into the wood.
- When the base assembly bottoms out against the depth of cut adjustment knob setting, pull back releasing pressure on the spring. Blade will retract from biscuit slot.
- Repeat this procedure for all desired biscuit slots and cutting the slots in the mating workpiece.
- Once all biscuit slots have been cut, place a biscuit in each joint and dry assemble the workpieces. Make sure each joint lines up and fits.
- Finally, disassemble the workpieces and place a bead of glue in each slot. Also, spread a bead of glue over the entire surface of the joint. Reinsert the biscuits and assemble the workpieces. See Figure 8.

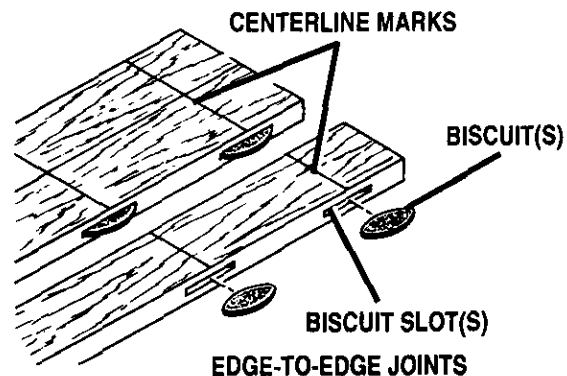

Fig. 8

- Clamp workpieces together until the glue sets up.

OPERATION

BUTT JOINTS

See Figure 9.

A butt joint is one of the weakest joints in woodworking. This type of joint is mating the end grain of one board with the edge grain of another. The bonding of glue on this type of surface is poor. However, by using biscuits you can create a stronger joint that gives a mortise-and-tenon effect.

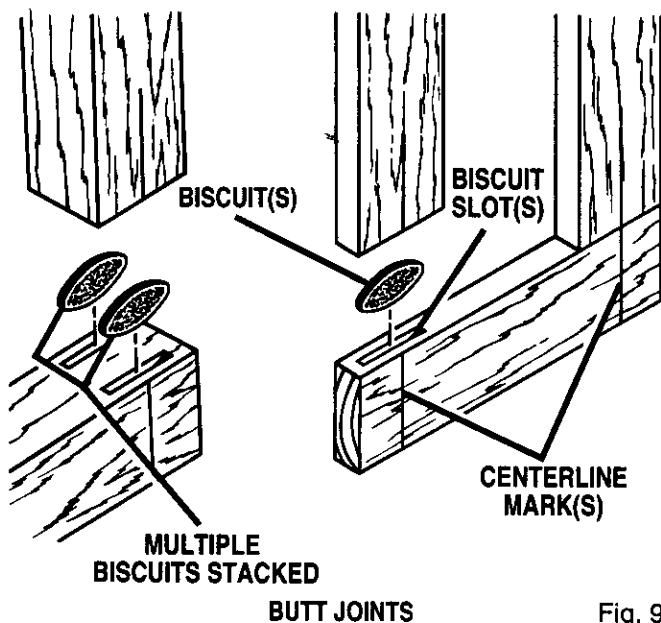

Fig. 9

HOW TO MAKE BUTT JOINTS

- Unplug your Detail Biscuit Joiner.
- Place the two pieces of wood to be joined on a level workbench. Align them against each other in the arrangement in which they will be assembled.
- Using a square, determine the location of each biscuit spline joint and mark the center of each joint by drawing a line across the edges of the two boards.
- Set fence angle at 90°.
- Loosen height adjustment knobs, then pull and slide the fence up or down until the indicator point is aligned with the desired dimension on the scale. **Remember:** The scale indicates the height of the fence from the center of the blade.
- Tighten height adjustment knobs securely.
- Select the correct depth of cut setting to match the biscuit size you are planning to use. We suggest that you make a test cut in a scrap piece of wood from the same workpiece if possible.
- Clamp workpiece securely so that it will not move during the cut.
- Plug your Biscuit Joiner into power supply and prepare to make your first cut. Grasp and hold your Biscuit Joiner securely with both hands.

- Place the fence against the board and align the indicator marks on the fence with the centerline mark(s) on the board.
- Depress the switch trigger and let the motor build to its maximum speed, then gradually push Biscuit Joiner forward to extend the blade into the wood.
- When the base assembly bottoms out against the depth of cut adjustment knob setting, pull back releasing pressure on the spring. Blade will retract from biscuit slot.
- Repeat this procedure for cutting the slot in the mating workpiece.
- Once all biscuit slots have been cut, place a biscuit in each joint and dry assemble the workpieces. Make sure each joint lines up and fits.
- Finally, disassemble the workpieces and place a bead of glue in each slot. Also, spread a bead of glue over the entire surface of the joint. Reinsert the biscuits and assemble the workpieces. See Figure 9.
- Clamp workpieces together until the glue sets up.

OFFSET BUTT JOINTS

See Figure 10.

The rails of a table or workbench are often offset from the front of the table legs. When offsets are required, it is necessary to cut the slots in the rails first, then re-adjust the fence to cut the slots in the legs.

Keeping this one exception in mind, the procedure for cutting offset butt joints is identical to the procedure for cutting butt joints.

For example — If a 1/4 in. offset is desired, you would mark the centerlines for cutting a butt joint as mentioned in the procedures for cutting butt joints, and cut the slots in the ends of the rails. Next you would raise the fence 1/4 in. to the desired offset and cut the slots in the legs.

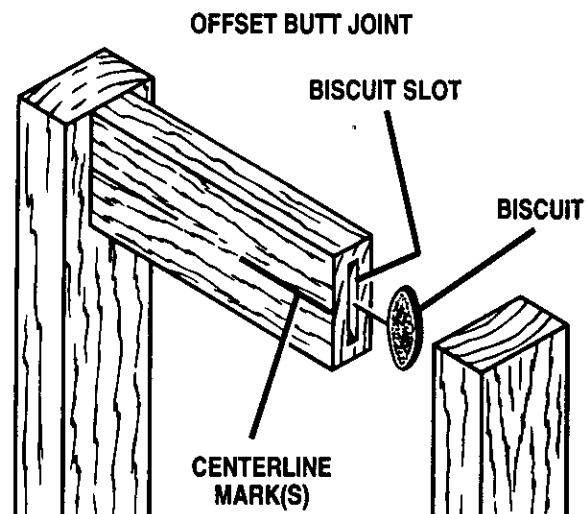

Fig. 10

OPERATION

T- JOINTS

See Figures 11-15.

A T-joint is used when the end of a board is joined to the face of another board as shown in figure 11. Attaching shelves to bookcases and inner support braces to frames are typical applications. Actual cutting of a T-joint is as simple as any other cut. However, it is critical that you mark the centerlines, mark the intersection points for each slot, and cut each slot correctly. See Figure 11.

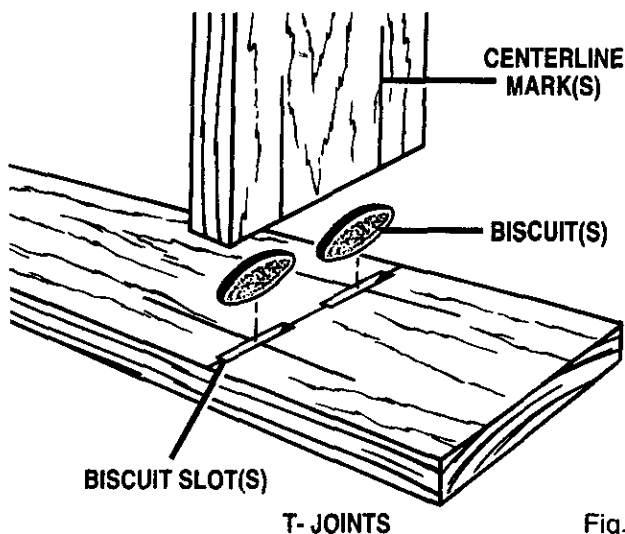

Fig. 11

HOW TO MAKE T- JOINTS

- Unplug your Detail Biscuit Joiner.
- Place the two pieces of wood to be joined on a level workbench as shown in Figure 12. The inside face of the vertical board should be facing up.

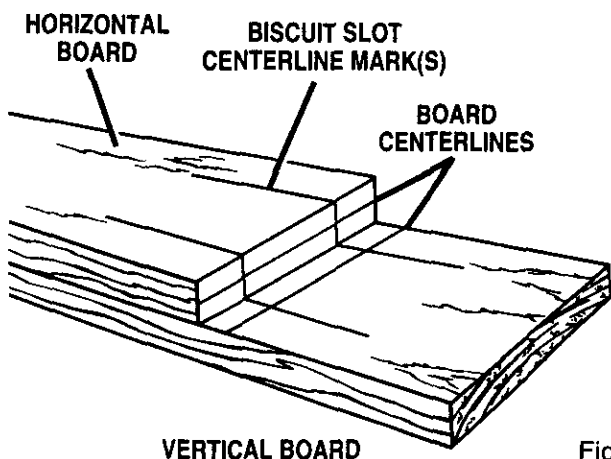

Fig. 12

- Determine the location of each biscuit joint and mark the centerlines on each board as shown. The centerlines for both boards must line-up with each other. Measure carefully, these measurements must be accurate and precise. **Tip:** Measure twice and cut once. In addition to the centerlines lining up, the spacing of the biscuit slots from side-to-side must also match.

- Plug your Biscuit Joiner into power supply and cut slots in all boards that require end slots. See Figure 13. Follow procedures explained in "Edge-To-Edge Joints". Rotate fence angle to 90°, set fence height at desired dimension on the scale, select the correct depth of cut setting for the biscuit size you plan to use, clamp workpiece securely, then cut each slot at the marked centerline intersection.

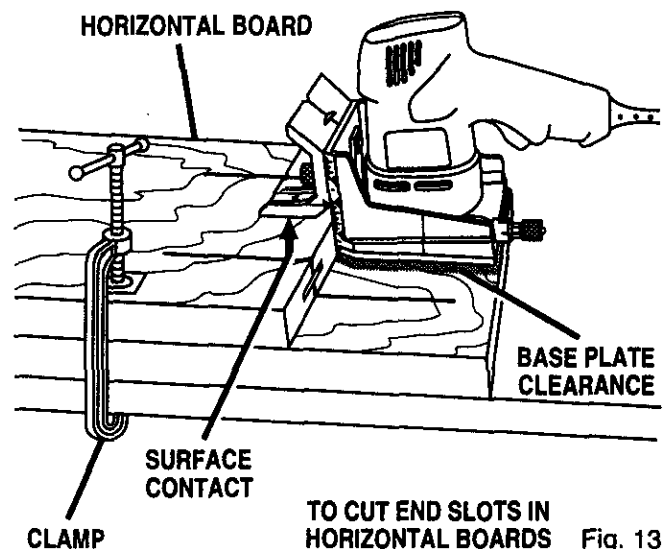

Fig. 13

- Next, you must remove the fence from your Biscuit Joiner in order to cut slots into the face of the vertical board.

TO REMOVE FENCE:

- Unplug your Detail Biscuit Joiner.
- Loosen height adjustment knobs, pull fence forward and slide it down the front base until it can be removed through the key hole slots. See Figure 14. Next, select the correct depth of cut setting for the biscuit size you plan to use, clamp workpiece securely, and cut each slot at the marked centerline intersection.

⚠ WARNING: When the fence is removed, the cutter may be exposed. Use extreme caution to avoid serious personal injury.

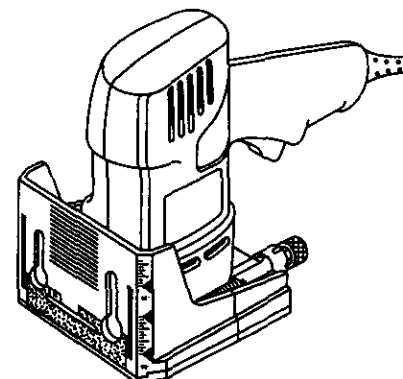

REMOVE FENCE TO MAKE FACE CUTS IN VERTICAL BOARDS

Fig. 14

OPERATION

T-JOINTS (Continued)

- Place your Biscuit Joiner on vertical board as shown in Figure 15 and align indicator marks on bottom shoe with centerline on vertical board.

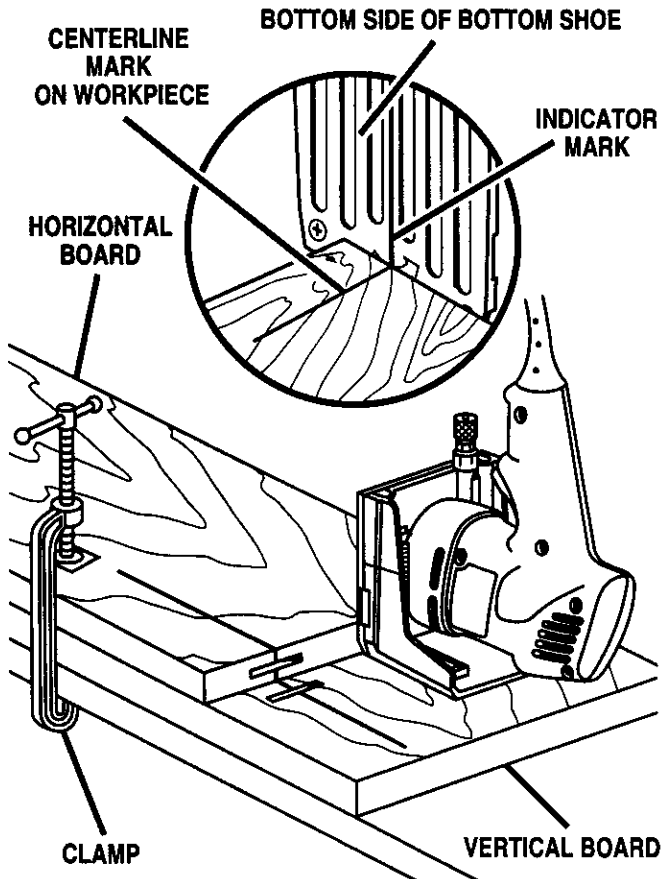

TO CUT SLOTS IN VERTICAL BOARDS Fig. 15

- Place a straight piece of wood on the vertical board and securely clamp it flush against the bottom shoe. This piece of wood is used for a fence or guide. It must be square with the sides of the vertical board and parallel with the centerline.
- Align centerline on bottom of shoe with marked intersection for biscuit slot.
- Plug your Biscuit Joiner into power supply and prepare to cut slot.
- Depress the switch trigger and let the motor build to its maximum speed, then gradually push Biscuit Joiner forward to extend the blade into the wood.
- When the base assembly bottoms out against the depth of cut adjustment knob setting, pull back releasing pressure on the spring. Blade will retract from biscuit slot.
- Repeat this procedure for cutting all required slots in vertical boards.
- Once all slots have been cut, place a biscuit in each joint and dry assemble the workpieces. Make sure each joint lines up and fits.

- Finally, disassemble the workpieces and place a bead of glue in each slot. Also, spread a bead of glue over the entire surface of the joint. Reinsert the biscuits and assemble the workpieces. See Figure 11.

- Clamp workpieces together until the glue sets up. Upon completion of a T-joint cutting operation, reinstall the fence on the front base by reversing "TO REMOVE FENCE" procedure. Place height adjustment knob bolts in key hole slots and align bolt heads with the slots on back of front base. Slide fence up the front base to desired depth of cut. Tighten height adjustment knobs securely.

MITER JOINTS

See Figures 16-18.

There are two types of miter joints that can be made using biscuits: flat miters and edge miters. Flat miters are used when making picture frames. Edge miters are used when making boxes or things where you don't want to show the end grain of the wood. Butt joints show the end grain in wood.

HOW TO MAKE FLAT MITER JOINTS

- Unplug your Detail Biscuit Joiner.

WARNING: Failure to unplug your Detail Biscuit Joiner could result in accidental starting causing possible serious personal injury.

- Place the pieces of wood to be joined on a level workbench as shown in Figure 16.

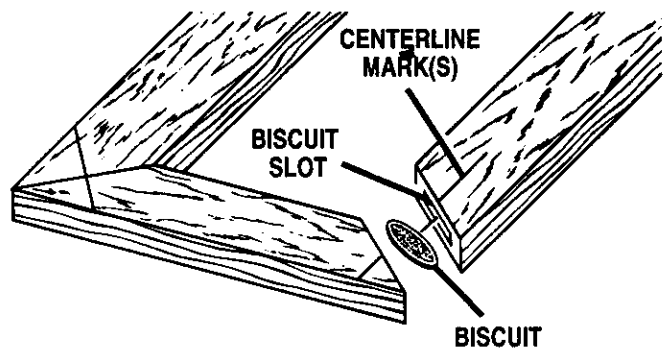

FLAT MITER JOINTS Fig. 16

- Using a combination square, draw a line through the center of each joint perpendicular to the mitered edges.
- Set fence angle at 90°, set fence height at desired dimension on the scale, select the correct depth of cut setting for the biscuit size you plan to use, and clamp workpiece securely.
- Align indicator mark on fence with the centerline on the workpiece.
- Plug your Biscuit Joiner into power supply and prepare to cut slot.

OPERATION

FLAT MITER JOINTS (Continued)

- Depress the switch trigger and let the motor build to its maximum speed, then gradually push Biscuit Joiner forward to extend the blade into the wood.
- When the base assembly bottoms out against the depth of cut adjustment knob setting, pull back releasing pressure on the spring. Blade will retract from biscuit slot.
- Repeat this procedure for cutting mating slot and all required miter joint slots.
- Once all slots have been cut, place a biscuit in each joint and dry assemble the workpieces. Make sure each joint lines up and fits.
- Finally, disassemble the workpieces and place a bead of glue in each slot. Also, spread a bead of glue over the entire surface of the joint. Reinsert the biscuits and assemble the workpieces. See Figure 16.
- Clamp workpieces together until the glue sets up.

HOW TO MAKE EDGE MITER JOINTS

- Unplug your Detail Biscuit Joiner.
- Place the pieces of wood to be joined on a level workbench as shown in Figure 17.

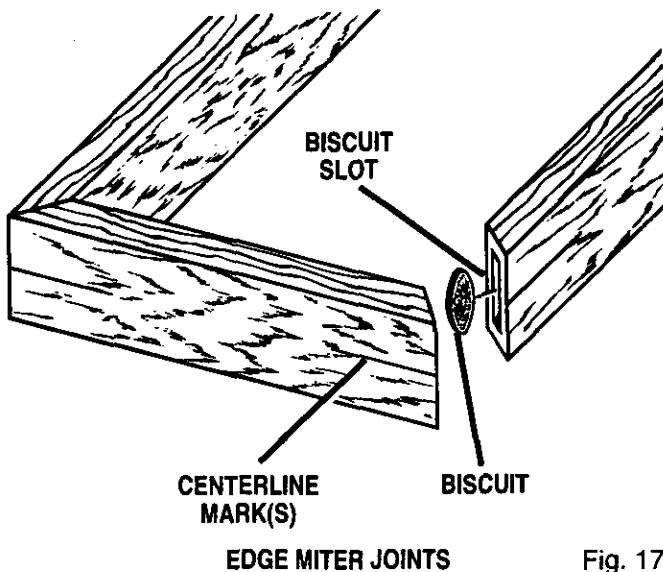

Fig. 17

- Mark centerline of the joint on each board.
- When making edge miter joints with workpieces that have different thicknesses, clamp securely to a workbench with the long sides up. This will assure that the outside surfaces will match. See Figure 18.
- Set fence angle at 45°.
- Slide the fence up or down until fence height is at desired setting.
- Tighten height adjustment knobs securely.

- Place your Biscuit Joiner on workpiece with the fence resting on the long side of workpiece as shown in Figure 18. The front base should be against the mitered edge of the workpiece.

CUTTING EDGE MITER SLOT FROM LONG SIDE OF WORKPIECE

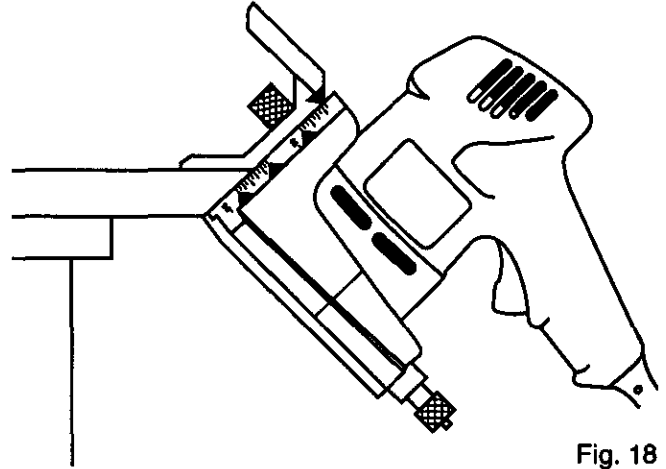

Fig. 18

- Recheck fence height setting to make sure it will not cut through the workpiece.
- Align indicator mark on fence with the centerline on the workpiece. Make sure the front base is pressed flat against the mitered edge of the workpiece.
- Plug your Biscuit Joiner into power supply and prepare to cut slot.
- Depress the switch trigger and let the motor build to its maximum speed, then gradually push Biscuit Joiner forward to extend the blade into the wood.
- When the base assembly bottoms out against the depth of cut adjustment knob setting, pull back releasing pressure on the spring. Blade will retract from biscuit slot.
- Repeat this procedure for cutting mating slot and all required miter joint slots.
- Once all slots have been cut, place a biscuit in each joint and dry assemble the workpieces. Make sure each joint lines up and fits.
- Finally, disassemble workpieces and place a bead of glue in each slot. Also, spread a bead of glue over the entire surface of the joint. Reinsert the biscuits and assemble workpieces. See Figure 17.
- Clamp workpieces together until the glue sets up.

OPERATION

HINGE JOINTS

See Figure 19.

Hinge joints are used when joining two boards using hinges supplied in one of Craftsman's optional hinge kits. Jewelry boxes, doors on clocks, recipe boxes, etc. are typical applications.

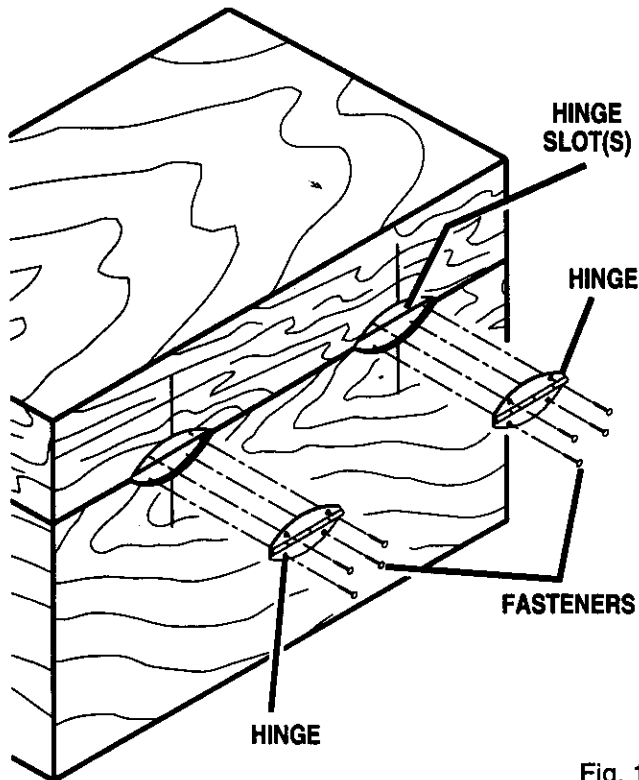

Fig. 19

HOW TO MAKE HINGE JOINTS

- Unplug your Detail Biscuit Joiner.

⚠ WARNING: Failure to unplug your Detail Biscuit Joiner could result in accidental starting causing possible serious personal injury.

- Prepare the workpieces to be joined by laying them side by side on a workbench in the order in which they will be hinged.

- Determine the location of each hinge joint and mark the center of each joint by drawing a line across each workpiece.
- Set fence angle at 90°.
- Loosen height adjustment knobs, then pull and slide the fence down the scale until the height indicator mark is set at zero depth of cut.
Remember: The scale indicates the height of the fence from the center of the blade, which is approximately .050 of an inch.
- Tighten height adjustment knobs securely.
- Select the #3 depth of cut setting. We suggest that you make a test cut in a scrap piece of wood from the same workpiece if possible.
- Clamp workpiece securely so that it will not move during the cut.
- Plug your Biscuit Joiner into power supply and prepare to make your first cut. Grasp and hold your Biscuit Joiner securely with both hands.
- Place the fence against the board and align the indicator marks on the fence with the centerline mark(s) on the board. See Figure 19.
- Depress the switch trigger and let the motor build to its maximum speed, then gradually push Biscuit Joiner forward to extend the blade into the wood.
- When the base assembly bottoms out against the depth of cut adjustment knob setting, pull back releasing pressure on the spring. Blade will retract from hinge slot.
- Repeat this procedure for all desired hinge slots.
- Once all hinge slots have been cut, place a hinge in each slot and dry assemble the workpieces. Make sure each slot lines up and fits.
- Finally, assemble the hinges to the workpieces and secure with the fasteners supplied.

MAINTENANCE

BLADE REPLACEMENT

See Figures 20-22.

After extended use, the blade on your Biscuit Joiner may become dull. If you accidentally hit a nail or other blunt object, it will dull or break the blade. These situations require replacing the blade.

HOW TO REPLACE THE BLADE

- Unplug your Detail Biscuit Joiner.

⚠ WARNING: Failure to unplug your Detail Biscuit Joiner could result in accidental starting causing possible serious personal injury.

- Place your Biscuit Joiner upside down on a workbench and remove the bottom shoe screws (4) and bottom shoe. See Figure 20.

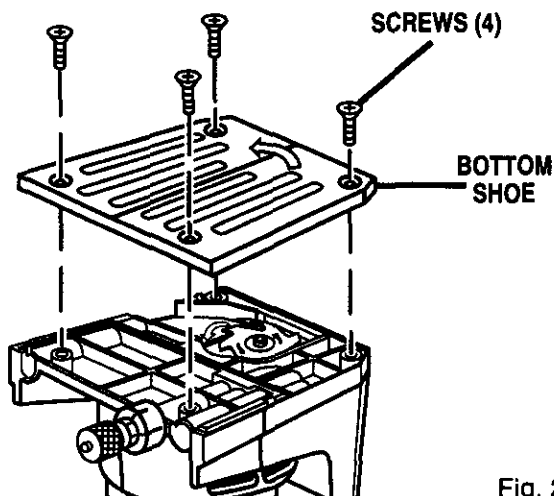

Fig. 20

- Place a #1 Phillips screwdriver or 3/16 in. diameter pin between the blade and front base. See Figure 21.
- Place one of the blade teeth against the screwdriver or pin and lock blade preventing it from rotating.

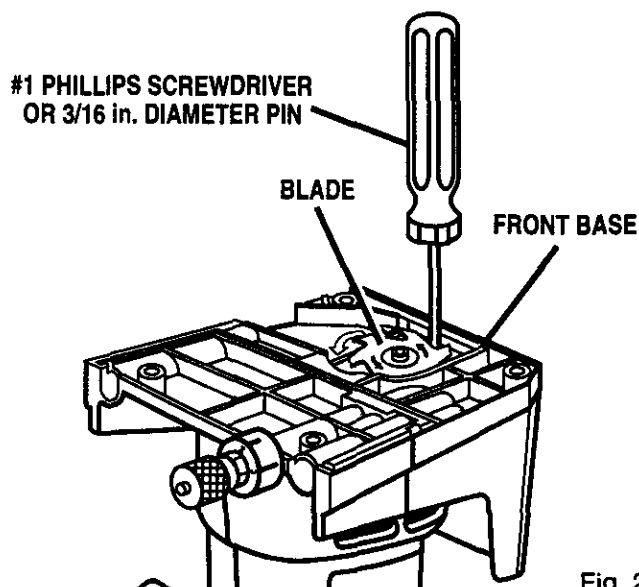

Fig. 21

- Using a 9/64 in. hex key, remove blade screw.

Note: Turn blade screw counterclockwise to remove. See Figure 22.

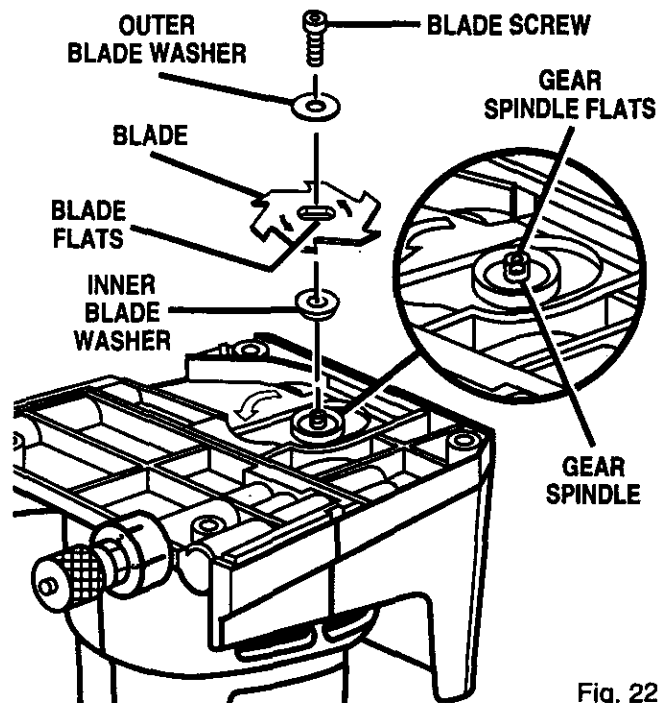

Fig. 22

- Remove outer blade washer and blade.
- Clean wood particles and resin from blade washer and all surrounding parts.

⚠ WARNING: If inner blade washer has been removed, replace it before installing new blade. Failure to do so could cause an accident since blade screw will not tighten properly.

- Place inner blade washer on gear spindle. See Figure 22.
- Place new blade onto gear spindle and align flats on blade with flats on gear spindle.
- Secure with outer blade washer and blade screw.
- Place a #1 Phillips screwdriver or 3/16 in. diameter pin between the blade and front base. See Figure 21.
- Place one of the blade teeth against the screwdriver or pin and lock blade preventing it from rotating.

Note: Blade teeth point toward the right of your Biscuit Joiner when held in normal operating position. An arrow on the bottom shoe also indicates direction of blade rotation. See Figure 20.

- Tighten blade screw securely.
- Note:** Turn blade screw clockwise to tighten.
- Reassemble bottom shoe.
- Replace screws (4) and tighten securely.

MAINTENANCE

⚠ WARNING: When servicing, use only identical Craftsman replacement parts. Use of any other part may create a hazard or cause product damage.

CLEANING BASE ASSEMBLY

See Figures 23-25.

After extended use, wood particles and resin may build up inside the base assembly of your Biscuit Joiner and clog the path for wood particles going through dust exhaust opening. Wood particles packing up in this area makes cutting biscuit slots more difficult.

HOW TO CLEAN BASE ASSEMBLY

■ Unplug your Detail Biscuit Joiner.

⚠ WARNING: Failure to unplug your Detail Biscuit Joiner could result in accidental starting causing possible serious personal injury.

- Place your Biscuit Joiner upside down on a workbench and remove the bottom shoe screws (4) and bottom shoe.
- Remove the blade. See "Blade Replacement" section.
- With your Biscuit Joiner still upside down on a workbench, remove front base screws (2). See

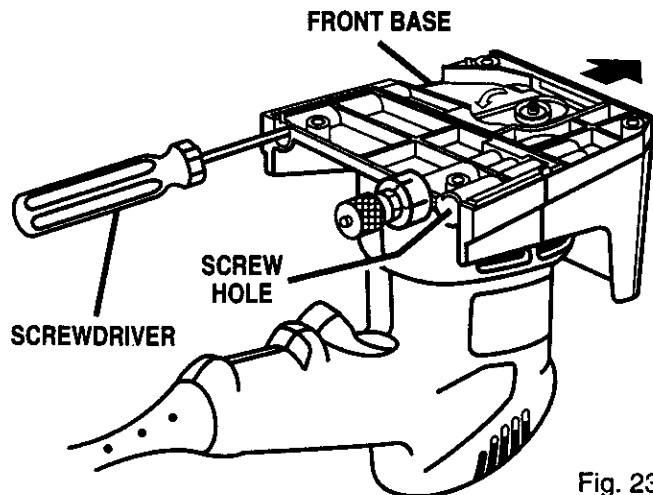

Fig. 23

- Figure 23.
- Pull front base in the direction shown by the arrow in Figure 23 and remove.
 - Using a pair of needle nose pliers, stretch and release springs from tabs on bearing plate. See Figure 24.
 - Lift adjustment rod away from bearing plate and remove rear base.
 - With front and rear base assemblies removed, place your Biscuit Joiner upside down on a workbench and clean wood particles and resin from bearing plate and surrounding areas. **Note:** Also clean the blade, blade washers, etc.

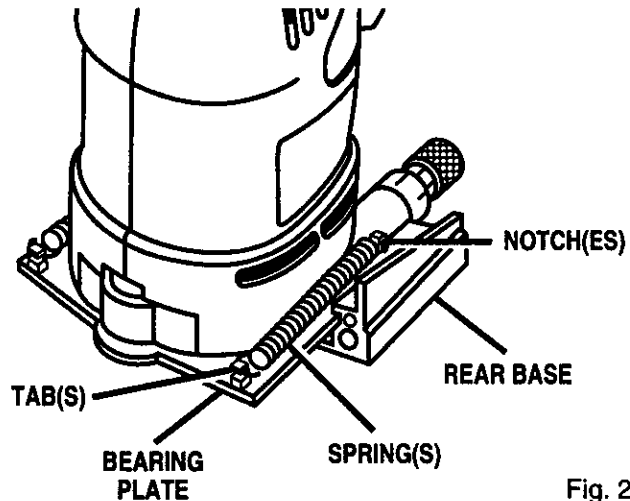

Fig. 24

⚠ CAUTION: Blade tips are sharp. Be careful not to cut yourself when cleaning.

- Clean wood particles and resin from slots and surrounding areas on front and rear base. See Figure 25. Apply a thin coat of general purpose grease in slots or on bearing plate where base slides.

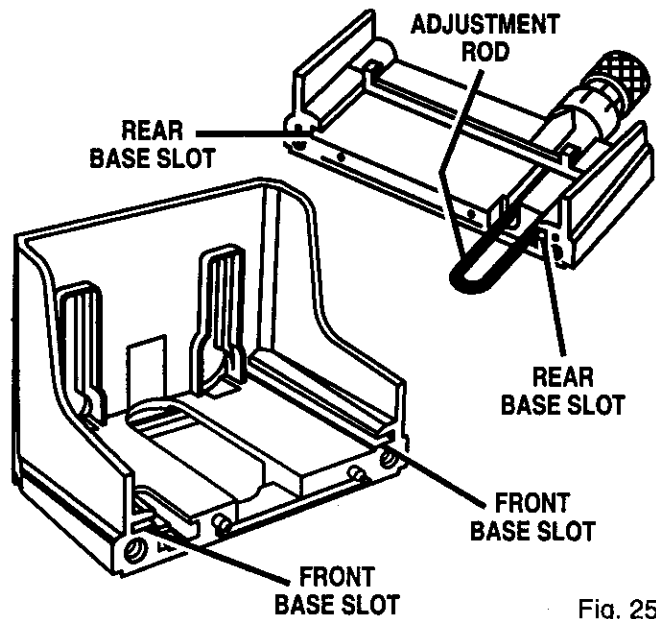

Fig. 25

- Replace rear base. Position adjustment rod in its proper place as shown in Figure 25.
- Secure rear base in place with the two springs. Hook one end of each spring in notch on each side of rear base. Using needle nose pliers, stretch each spring and hook it over tabs on bearing plate.
- Reassemble front base. Replace screws and tighten securely.
- Reinstall blade. Tighten blade screw securely.
- Reassemble bottom shoe. Tighten screws (4) securely.

MAINTENANCE

GENERAL

Only the parts shown on parts list, page 23, are intended to be repaired or replaced by the customer. All other parts represent an important part of the double insulation system and should be serviced only by a qualified Sears service technician.

Avoid using solvents when cleaning plastic parts. Most plastics are susceptible to damage from various types of commercial solvents and may be damaged by their use. Use clean cloths to remove dirt, carbon dust, etc.

⚠ WARNING: Do not at any time let brake fluids, gasoline, petroleum-based products, penetrating oils, etc. come in contact with plastic parts. They contain chemicals that can damage, weaken or destroy plastic.

It has been found that electric tools are subject to accelerated wear and possible premature failure when they are used on fiberglass boats, sports cars, wallboard, spackling compounds, or plaster. The chips and grindings from these materials are highly abrasive to electric tool parts such as bearings, brushes, commutators, etc. Consequently, it is not recommended that this tool be used for extended work on any fiberglass material, wallboard, spackling compounds, or plaster. During any use on these materials it is extremely important that the tool is cleaned frequently by blowing with an air jet.

LUBRICATION

All of the bearings in this tool are lubricated with a sufficient amount of high grade lubricant for the life of the unit under normal operating conditions. Therefore, no further lubrication is required.

⚠ WARNING: Always wear safety goggles or safety glasses with side shields during power tool operation or when blowing dust. If operation is dusty, also wear a dust mask.

EXTENSION CORDS

The use of any extension cord will cause some loss of power. To keep the loss to a minimum and to prevent tool overheating, use an extension cord that is heavy enough to carry the current the tool will draw.

A wire gage size (A.W.G.) of at least 16 is recommended for an extension cord 100 feet or less in length. When working outdoors, use an extension cord that is suitable for outdoor use. The cord's jacket will be marked **WA**.

⚠ CAUTION: Keep extension cords away from the cutting area and position the cord so that it will not get caught on lumber, tools, etc., during cutting operation.

⚠ WARNING: Check extension cords before each use. If damaged replace immediately. Never use tool with a damaged cord since touching the damaged area could cause electrical shock resulting in serious injury.

Extension cords suitable for use with your Biscuit Joiner are available at your nearest Sears Retail Store.

HELPFUL HINTS

- ✓ Always clamp workpiece securely before cutting.
- ✓ A safe operator is one who thinks ahead.
- ✓ Always wear eye protection when cutting slots.
- ✓ Make set-up adjustments carefully. Then double check. Measure twice and cut once.
- ✓ Always dry assemble your project before gluing it together.
- ✓ For loose fit situations, wet biscuits to make them swell.
- ✓ The more biscuits used, the stronger the joint will be.
- ✓ Keep blade clean. When the blade becomes dull, replace it.
- ✓ Don't let familiarity make you careless.
- ✓ Study all safety rules and do the job safely.
- ✓ **Never** place your hands in jeopardy.
- ✓ Make certain clamps can't loosen while in use.
- ✓ Test difficult set-ups on scrap—Don't waste lumber.
- ✓ Plan each operation before you begin.
- ✓ Provide for smoother operation by cleaning your Biscuit Joiner frequently. Shake Biscuit Joiner or blow with an air jet to remove wood particle build-up.
- ✓ **Do not abuse power tools.** Abusive practices can damage tool as well as workpiece.
- ✓ **Think safety by thinking ahead.**

TROUBLESHOOTING

PROBLEM

SOLUTION

1. Biscuits do not fit slots. Biscuits not fitting slots may also cause misalignment of boards being joined.

- A. Biscuit slots are too deep or too shallow. Make fine adjustments to depth setting. See "**TO MAKE FINE ADJUSTMENTS**" section on page 10.
- B. Biscuit thickness may be out of tolerance. Compress biscuits in a vise if they are too thick.
- C. Check to see if biscuits are the correct size for the size slots that have been cut: #1, #2, or #3.
- D. Check to see if biscuits have gotten wet and swollen.
- E. If biscuits fit loose in slots, wet them to take up the loose fit.

2. Wood particles begin to backup on front of unit.

- A. Dust exhaust may be clogged preventing wood particles from going through dust exhaust opening. Remove bottom shoe and clean blade, bearing plate, base assembly slots, and surrounding areas. See "**CLEANING BASE ASSEMBLY**" section on page 19.

3. Blade becomes difficult to push in when cutting slots. Blade does not retract properly when cutting slots.

- A. Wood particles and resin have built up on base assembly slots and surrounding areas. Remove front and rear base assemblies and clean blade, bearing plate, base assembly slots and surrounding areas. Apply a thin coat of general purpose grease in slots or on bearing plate where base slides. See "**CLEANING BASE ASSEMBLY**" section on page 19.

4. Cutting performance is poor and there is a loss of power or stalling of motor when cutting slots.

- A. Blade is dull. Replace blade. See "**BLADE REPLACEMENT**" section on page 18.
- B. Resin has built up on blade. Remove blade and clean it with gum and pitch remover. See "**BLADE REPLACEMENT**" section on page 18 for blade removing instructions. Once clean, follow "**BLADE REPLACEMENT**" instructions to replace the blade.

CRAFTSMAN DETAIL BISCUIT JOINER - MODEL NUMBER 315.175500

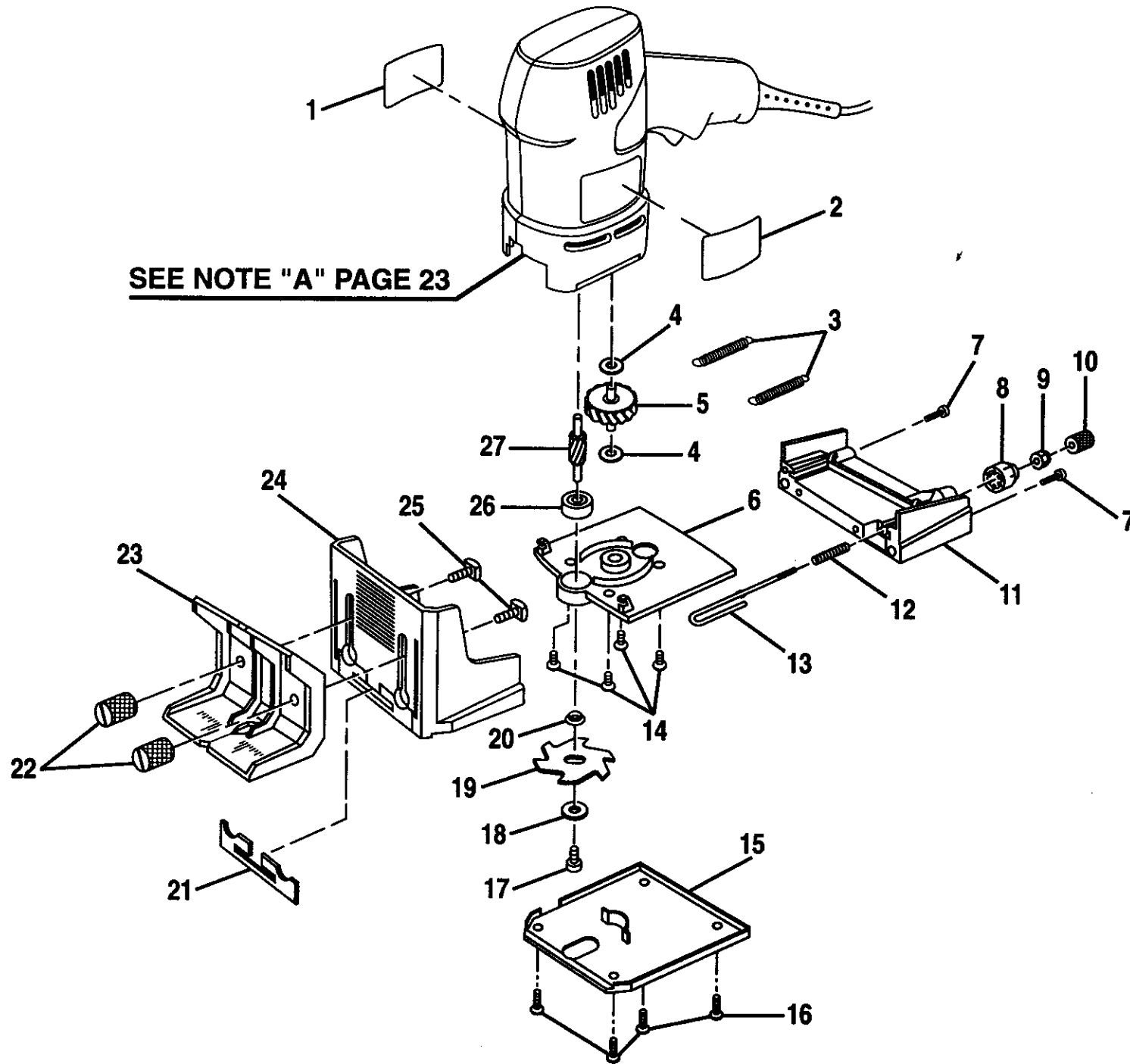

CRAFTSMAN DETAIL BISCUIT JOINER - MODEL NUMBER 315.175500

The model number will be found on a plate attached to the motor housing. Always mention the model number in all correspondence regarding your **DETAIL BISCUIT JOINER** or when ordering repair parts.

SEE BACK PAGE FOR PARTS ORDERING INSTRUCTIONS

PARTS LIST

Key No.	Part Number	Description	Quan.	Key No.	Part Number	Description	Quan.
1	975787-001	Data Plate	1	15	974212-001	Shoe	1
2	975788-001	Logo Plate	1	16	622210-040	* Screw (#8-32 x 1/2 in. Flat Hd. T.C.)	4
3	663711-001	Tension Spring	2	17	612284-002	Blade Screw (#8-32 x 3/8 in. Soc. Cap)	1
4	931055-806	Washer	2	18	974209-001	Outer Blade Washer	1
5	975193-001	Gear Assembly	1	19	975796-001	Blade	1
6	974204-002	Bearing Plate With Bearing	1	20	974199-001	Inner Blade Washer	1
7	623275-003	* Screw (#10-24 x 3/4 in. Fil. Hd.)	2	21	974217-001	Front Base Pad	1
8	974219-002	Depth Adjustment Knob	1	22	974220-001	Height Adjustment Knob	2
9	703477-006	* Jam Nut (#8-32)	1	23	974221-001	Adjustable Fence	1
10	971498-001	Knurled Adjustment Knob	1	24	974210-002	Front Base	1
11	974211-001	Rear Base	1	25	623166-002	Bolt (1/4-20 x 3/4 in. Sq. Hd.)	2
12	663703-001	Compression Spring	1	26	974208-001	Ball Bearing (NMB R-1560X2ZZR)	1
13	974218-001	Adjustment Rod	1	27	975275-001	Gear	1
14	622183-042	* Screw (#8-32 x 3/8 in. Fil. Hd.)	4	28	975797-001	Optional Carbide Tipped Blade (Not Shown) .	1
					972000-415	Owner's Manual	

NOTE: "A"— The assembly shown represents an important part of the Double Insulated System. To avoid the possibility of alteration or damage to the system, service should be performed by your nearest Sears Repair Center. Contact your nearest Sears Retail Store for Service Center information.

* Standard Hardware Item — May Be Purchased Locally

For repair of major brand appliances **in your own home...**
no matter who made it, no matter who sold it!

1-800-4-MY-HOMESM Anytime, day or night
(1-800-469-4663)

www.sears.com

To bring in products such as vacuums, lawn equipment and electronics
for repair, call for the location of your nearest **Sears Parts & Repair Center.**

1-800-488-1222 Anytime, day or night

www.sears.com

For the replacement parts, accessories and owner's manuals
that you need to do-it-yourself, call **Sears PartsDirectSM!**

1-800-366-PART 6 a.m. – 11 p.m. CST,
(1-800-366-7278) 7 days a week

www.sears.com/partsdirect

To purchase or inquire about a Sears Service Agreement:

1-800-827-6655

7 a.m. – 5 p.m. CST, Mon. – Sat.

Para pedir servicio de reparación a domicilio,
y para ordenar piezas con entrega a domicilio:

1-888-SU-HOGARSM
(1-888-784-6427)

Au Canada pour service en français:

1-877-LE-FOYERSM
(1-877-533-6937)

SEARS
HomeCentralSM