

CRAFTSMAN.

**OWNERS
MANUAL**

**MODEL NO.
757.243481**

Caution:
Read Rules for
Safe Operation
and Instructions
Carefully

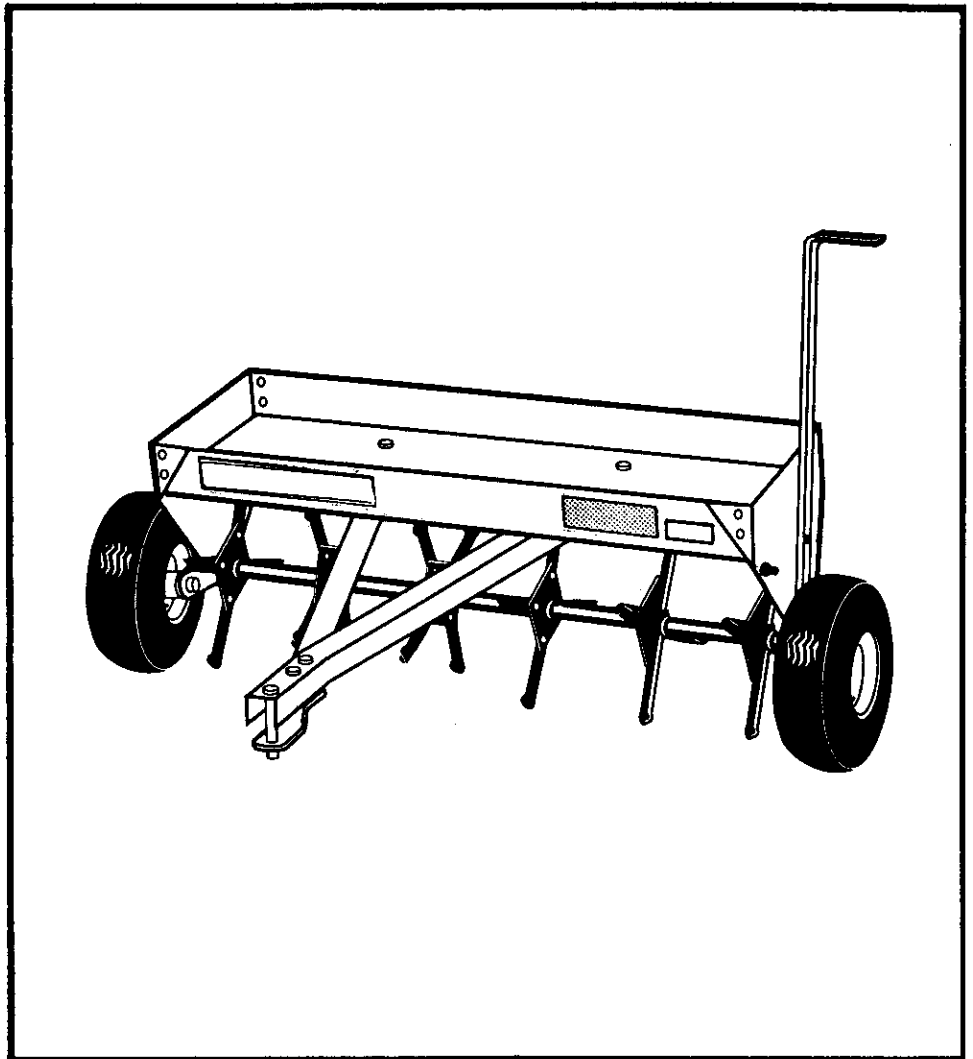

CRAFTSMAN®

**40"
LAWN AERATOR
(PLUG-TYPE)**

**FOR USE WITH RIDERS
AND LAWN/GARDEN TRACTORS**

- Assembly
- Installation
- Operation
- Repair Parts

LIMITED TWO YEAR WARRANTY ON AERATOR

For 2 years from the date of purchase, when this Aerator is maintained and lubricated according to the operating and maintenance instructions in the owner's manual, Sears will repair, free of charge, any defect in material or workmanship.

This warranty does not cover:

---repairs necessary because of operator abuse or negligence including the failure to maintain the equipment according to instructions contained in the owner's manual; and Aerator used for commercial or rental purposes.

WARRANTY SERVICE IS AVAILABLE BY RETURNING TO THE NEAREST SEARS SERVICE CENTER/DEPARTMENT IN THE UNITED STATES. This warranty applies only while this product is in use in the United States.

This warranty gives you specific legal rights and you may also have other rights which vary from state to state.

SEARS, ROEBUCK AND CO., D/817 WA, Hoffman Estates, IL 60179, U.S.A.

CONGRATULATIONS on your purchase of a Sears Craftsman Aerator. It has been designed, engineered and manufactured to give you the best possible dependability and performance.

Should you experience any problem you can not easily remedy, please contact your nearest Sears Service Center/Department. We have competent, well trained technicians and the proper tools to service or repair your Aerator.

Please read and retain this manual. The instructions will enable you to assemble and maintain your Aerator properly. Always observe the "SAFETY RULES".

- THE MODEL AND SERIAL NUMBERS WILL BE FOUND ON A DECAL ATTACHED TO THE FRONT CORNER OF THE TRAY.
- YOU SHOULD RECORD BOTH SERIAL NUMBER AND DATE OF PURCHASE AND KEEP IN A SAFE PLACE FOR FUTURE REFERENCE.

MODEL NUMBER	<u>757.243481</u>
SERIAL NUMBER	_____
DATE OF PURCHASE	_____

CUSTOMER RESPONSIBILITIES

- Read and observe the "SAFETY RULES".
- Follow a regular schedule in maintaining, caring for and using your Coring Aerator.

TABLE OF CONTENTS

WARRANTY.....	2	OPERATION.....	7
SAFETY RULES.....	3	CUSTOMER RESPONSIBILITY.....	7
CARTON CONTENTS.....	3 & 4	REPAIR PARTS.....	8
ASSEMBLY.....	5 & 6		



RULES FOR SAFE OPERATION

- Know controls and how to stop quickly, READ THE OWNER'S MANUAL.
- Do not allow children to operate the vehicle, do not allow adults to operate without proper instruction and without having read the owner's manual.
- Do not carry passengers. Keep children and pets a safe distance away.
- Always wear substantial footwear. Do not wear loose fitting clothing that can get caught in moving parts.
- Keep your eyes and mind on your tractor/attachment and area being covered. Don't let other interests distract you.
- Stay alert for holes in the terrain and other hidden hazards.
- Keep the vehicle and attachment in good operating condition and keep safety devices in place.
- Keep all nuts, bolts and screws tight to be sure the equipment is in safe working condition.
- The vehicle and attachment should be stopped and inspected for damage after striking a foreign object. The damage should be repaired before restarting and operating the equipment.
- See tractor equipment owner's manual for safe operation of the equipment.
- Do not drive close to creeks, ditches and public highways.
- Watch out for traffic when crossing or near roadways.
- When using any attachment, don't allow anyone near the vehicle while in operation.



CAUTION

- To avoid damage to Spoons, always engage transport wheels to raise the Spoons when crossing concrete or asphalt walks, drives, or roads.
- Use the Aerator only on an established lawn, never on newly laid sod.
- To avoid possible personal injury and/or equipment never exceed the recommended operating speed range of 3 to 5 MPH.
- Only tow your Aerator behind vehicles for which it was designed, lawn/garden tractors.
- Do not stand/ride on Aerator, bodily injury could result.
- Never exceed the Weight Tray capacity of 150 pounds.
- Do not attempt to disconnect Aerator from tractor with weight in Hopper.
- When backing, carefully back straight to avoid Jack-knifing, which could result in damage to equipment.



LOOK FOR THIS SYMBOL TO POINT OUT IMPORTANT SAFETY PRECAUTIONS. IT MEANS - ATTENTION! BECOME ALERT! YOUR SAFETY IS INVOLVED.

CONTENTS OF SHIPPING CARTON



No. A L-1590-SC-2
Owner's Manual
1 Used



No. B Z-1530
Hardware Bag
Plugging (Spoon) Tines
1 Used



No. C Z-1531
Hardware Bag
1 Used

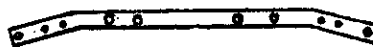

No. 9 B-5427-10
Frame Angle
2 Used



No. 12 B-4859-10
Lift Handle Assembly
1 Used

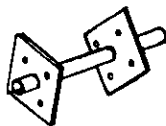

No. 13 B-5309-10
Outer Tube Assembly
2 Used



No. D Z-1531-A
Hardware Bag
Nylon Bearings
1 Used

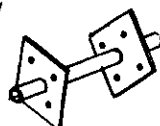

No. 14 B-5311-10
Center Tube Assembly
1 Used

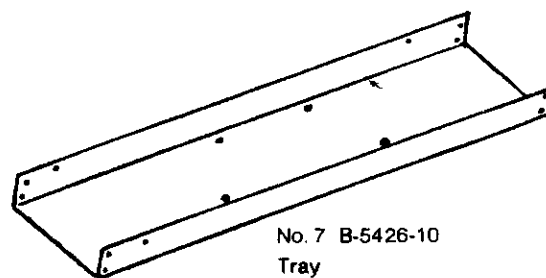

No. 7 B-5426-10
Tray
1 Used

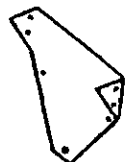

No. 6 B-4851-10
Side Plate
2 Used

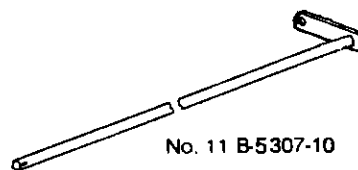

No. 11 B-5307-10
Axle Assembly
1 Used

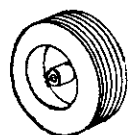

No. 18 B-4869
Transport Wheel
2 Used

Z-1531 HARDWARE BAG



No. 5 B-4786
Hex Lock Nut, 5/16"
17 Used



No. 26 40M1600P
Lock Washer, 1/2"
2 Used



No. 9 R-618
Heavy Washer- 5/16"
4 Used



No. 28 45M1717P
Flat washer, 1/2"
4 Used



No. 29 B-676P
Flat Washer, 3/4"
3 Used

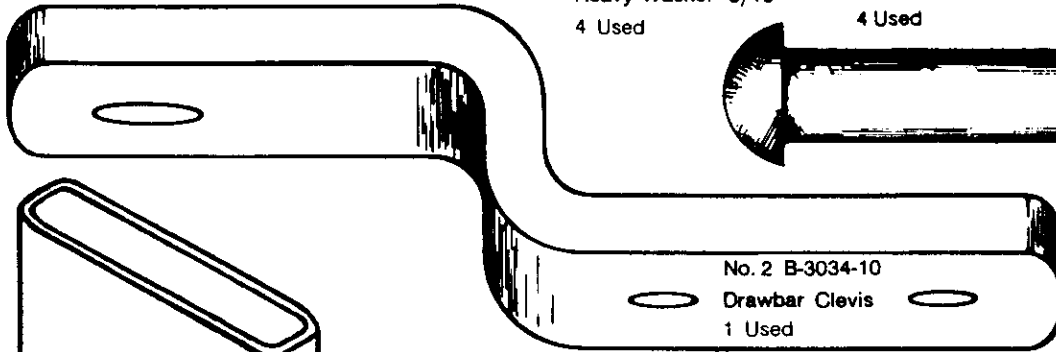

No. 2 B-3034-10
Drawbar Clevis
1 Used

No. 19 B-4870-01
Drawbar Pin
1/2" x 3-1/2"
1 Used

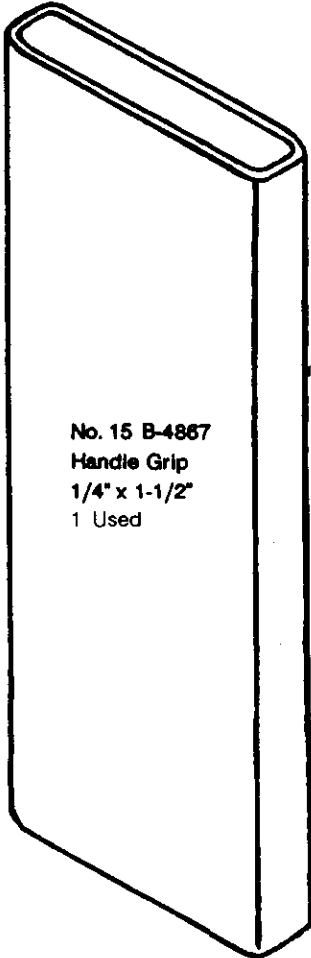

No. 15 B-4867
Handle Grip
1/4" x 1-1/2"
1 Used

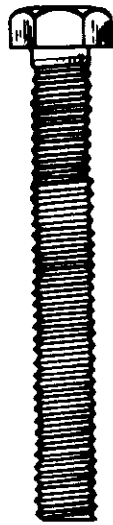

No. 17 B-4868
Hex Head Bolt
5/16" x 2-1/2"
2 Used

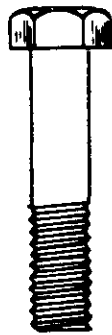

No. 21 2M1024P
Hex Head Bolt
5/16" x 1-1/2"
1 Used



No. 31 B-3307-S
Transport Lock
Pin
1 Used



No. 24 30M1000P
Hex Nut 5/16"
2 Used



No. 27 45M1111P
Flat washer, 5/16"
8 Used

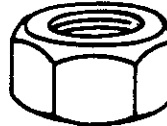

No. 25 30M1600P
Hex Nut, 1/2"
4 Used



No. 22 2M1012P
Hex Head Bolt
5/16" x 3/4"
13 Used



No. 23 2M1660P
Hex Head Bolt
1/2" x 3-3/4"
2 Used

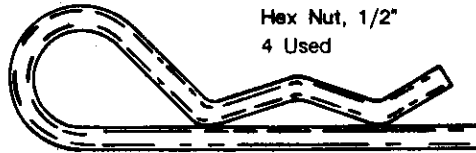

No. 20 D-146P
Hairpin Cotter, 1/8"
1 Used

Z-1530 HARDWARE BAG PLUGGING SPOON



No. 32 B-1674P
Hex Lock Nut, 5/16"
25 Used

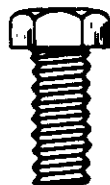

No. 22 2M1012P
Hex Head Bolt
5/16" x 3/4"
25 Used

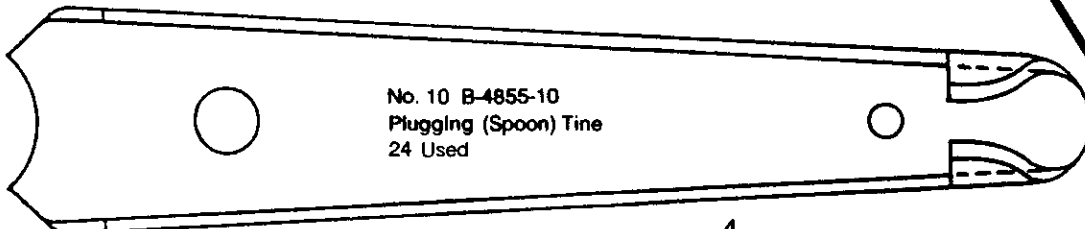

No. 10 B-4855-10
Plugging (Spoon) Tine
24 Used

HARDWARE BAG

DZ-1531-A

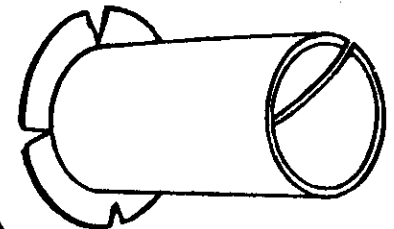

No. 16 B-4866
Nylon Bearing, 3/4" I.D.
6 Used

ASSEMBLY

It is recommended that you carefully read this Owner's Manual BEFORE starting assembly of this unit. Fold out the carton for use as a pad during assembly and arrange each kind of hardware into a group to ease assembly.

All reference to Right Hand and Left Hand are made while standing behind unit facing forward.

TOOLS REQUIRED FOR ASSEMBLY

- 1 - Pair Pliers
- 2 - 1/2" Wrenches
- 2 - 3/4" Wrenches
- OR
- 2 - 10" Adjustable wrenches

FRAME ASSEMBLY

Refer to Fig. 1

● Sit the Tray (7) on the pad with flanges facing up.

● Attach the Side Plates (6) to Tray as shown using eight 5/16"x3/4" Hex Bolts (22- from INSIDE of Tray), Flat Washers (27- next to Bolt heads) and Lock Nuts (5). Tighten all Bolts while maintaining 41" to 41-1/4" inside the Side Plates (6).

Refer to Figs. 1 & 2

● Assemble the Transport Lock Pin (31) into the front hole at Left Hand Side Plate (6) from the outside. Secure with 5/16" Lock Nut (5) holding Pin with Pliers as you tighten. This Pin is used to lock the Wheels in Transport.

Refer to Fig.2

● Attach the two Frame Angles (8) to underside of Tray (7) using four 5/16" x 3/4" Hex Bolts (22), Heavy Flat Washers (9) next to Frame Angle holes, and Nylon Insert Nuts (5). Do not tighten at this time.

● Align the front holes of Angles and fasten at two smaller holes using two 5/16"x2-1/2" full threaded Hex Bolts (17). Bolts extend inside legs of Angles and secure with 5/16" Hex (regular) Nuts (24). See Inset "A". Tighten these and Tray Bolts (22) securely.

● Assemble the Drawbar Clevis (2) to Full Threaded Bolts extending from Frame Angles, securing with two 5/16" Lock Nuts (5).

PLUGGING SPOON PRE-ASSEMBLY

Refer to Fig. 3.

(Center Tube [14] shown)

● Assemble Plugging Spoons (10) to each welded plate (SIDES OPPOSITE WELDS) of the three Tube Assemblies (13 & 14) using 5/16"x3/4" Hex Bolts (22) and Lock Nuts (32). Rounded part of Spoon fits against tube to lock in place. Tighten all 24 securely.

● Insert a 3/4" Nylon Bearing (16) into each end of Tube Assemblies.

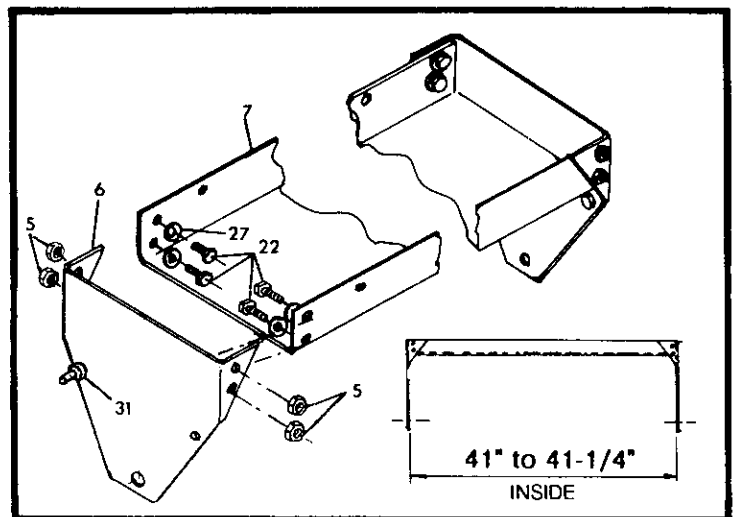

Fig. 1

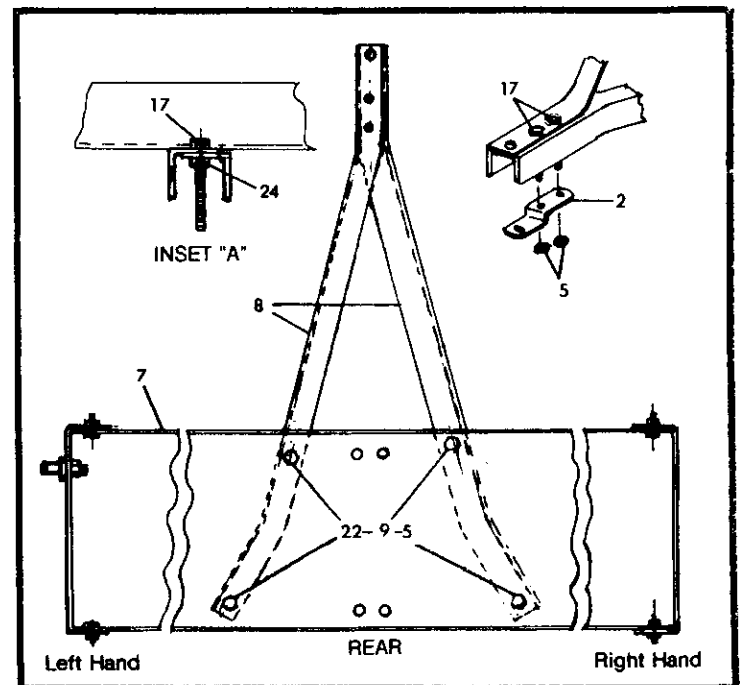

Fig. 2

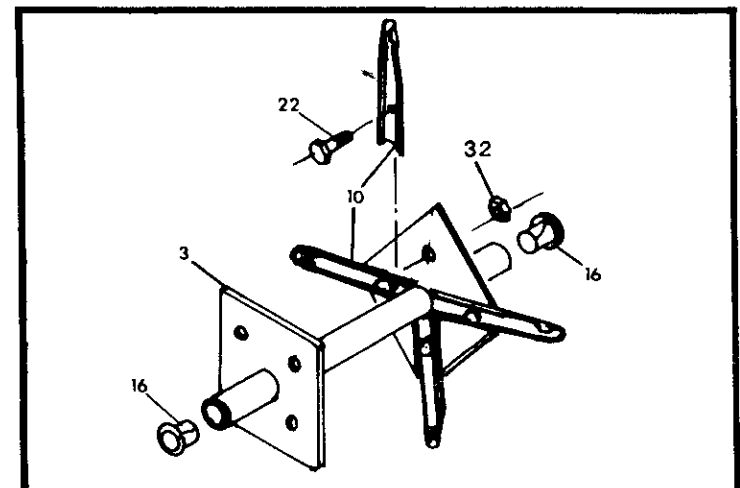

Fig. 3

PLUGGING UNIT ASSEMBLY

Refer to Fig. 4

- Identify the two Outer Tube Assemblies (13- has one plate welded close to end of tube) and the Center Tube Assembly (14- has both plates welded close to end of tube).
 - Insert the Axle Assembly (11) partially through hole in Side Plate (6) at RIGHT SIDE.
 - Install as follows:
 - 3/4" Flat Washer (29).
 - Outer Tube Assembly (13)- with short Hub end next to Right Side Plate.
 - 3/4" Flat Washer (29).
 - Center Tube Assembly (14).
 - 3/4" Flat Washer (29).
 - Outer Tube Assembly (13) with short Hub end next to Left Side Plate.
 - 3/4" Flat Washer (29).
- IMPORTANT:** Make sure Nylon Bearings are inside Tube Assemblies. See Fig.3.
- Align Axle Assembly shaft end with hole in Left Side Plate and push through as far as possible. Slide on a 3/4" Flat Washer (29).

- Install Lift Handle Assembly (12) over Axle Assembly Shaft- Welded Tube on Lift Handle FACING OUT.

- Position strap on Axle Assembly (at opposite side) in line with short end extending from Lift Handle (with Wheel mounting holes) and align holes in Handle Tube and Axle Shaft. Insert a 5/16"x1-1/2" Hex Bolt (21) and secure with a 5/16" Lock Nut (1).

- Slip Handle Grip (15) over end of Lift Handle.
NOTE: Soapy water will ease this assembly.

TRANSPORT WHEELS

Refer to Fig.5

- Pre-assemble the two Transport Wheels (18) using 1/2"x3-3/4" Hex Bolts (23) and Flat Washers (28) next to Bolt Head through Wheel Hubs (opposite extended Hub side).
- Install a Flat Washer (28) next to Hub and 1/2" Hex Nut (25) threaded on as far as possible with Bolt still free to turn.
- Install both Wheels through holes in Side Straps (11 & 12) securing with Lock Washers (26) and Hex Nuts (25). Tighten securely, but with Wheels free to turn.
- Check all fasteners for tightness. Your Aerator is now ready for use.

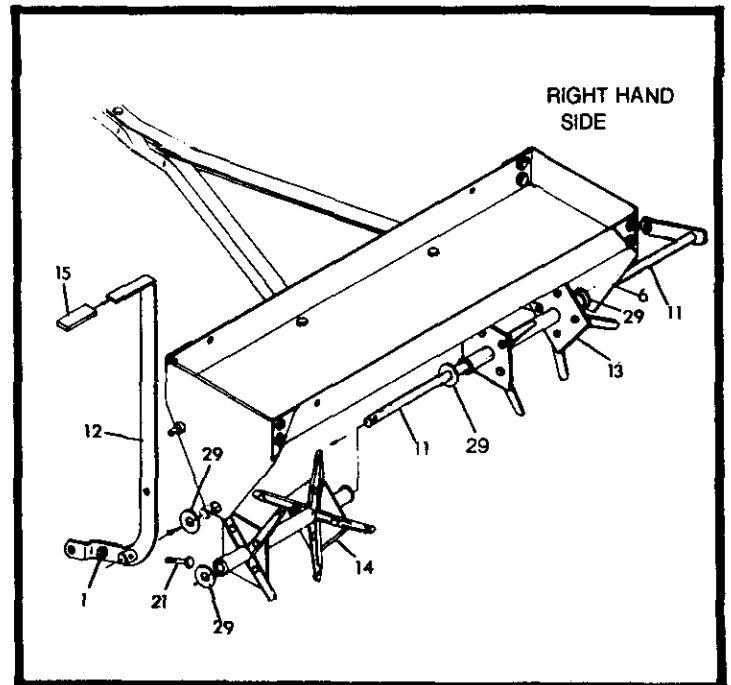

Fig. 4

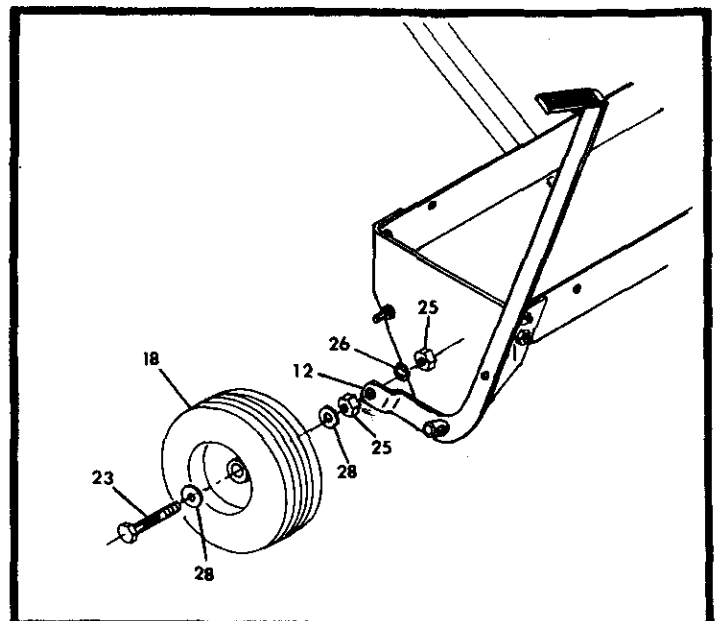

Fig. 5

OPERATION



WARNING

- To avoid personal injury and/or equipment damage, never exceed the recommended operating speed range of 3 to 5 MPH.

WHEN TO AERATE

Your Aerator should not be used when Lawn Conditions are too Wet or too Dry. To determine condition, dig a small amount of your soil (about three inches deep):

- If soil appears powdery and brittle- it is too dry. Wait until a later date, after a rainfall. If soil is too dry, the Plugging Spoons will not penetrate properly.
- If soil appears damp, roll a small amount into a ball in the palm of your hand- if it forms a ball, then it is too wet. Ideally, the soil should fall apart when rolled in the palm of your hand. Wait till a later date for soil to dry. If soil is too wet, the Plugging Spoons will stop up and your Tractor could lose traction, causing Lawn Damage

MOUNTING AND TRANSPORTING

- Attach Aerator to your Rider using Pin and Hairpin Cotter supplied.
- To place in Transport Position:
Pull FORWARD on Lift Handle (12) and move to Transport Lock Pin in Side Plate. Pull OUT and move Handle to Lock-in position. Aerator rests on Wheels.
- To place in Operating Position:
Pull OUT on Lift Handle (releasing from Transport Position) and move back. Aerator rests on Plugging Spoons.



CAUTION

- Use the Plugging Aerator only on established lawns, NEVER ON NEWLY LAID SOD.
- Never exceed the Weight Tray capacity of 150 pounds. If the Plugging Spoons are going too deep, remove some of the weight from the weight Tray.
- Always raise Plugging Spoons to Transport position when crossing asphalt or concrete.
- When backing - carefully back straight to avoid jackknifing, which could result in damage to equipment.

USE OF ADDITIONAL WEIGHT

The weight required to give a recommended penetration of approximately three inches will vary according to soil type and conditions. Concrete Blocks, Patio Blocks, Sand Bags, or any other type of weight can be added to Aerator Tray as required. Weight can be secured by using tie downs through holes in Tray Flanges. Tie downs are not furnished with your unit. Usually three Concrete Blocks will be sufficient, but more or less may be required.

- Drive your Tractor to location to be Aerated.
- Lower Aerator to Operating Position.
- Drive the Tractor FORWARD approximately ten feet and stop.
- Observe the operation- there should a Plug hole approximately every 10 inches to 12 inches and not more than 3 inches deep.
- Add or remove weight to obtain this condition.

CUSTOMER RESPONSIBILITY

- Should rust appear on any other part of your Aerator, sand lightly to remove rust and coat lightly with enamel.
- Apply a drop of lubricating oil to each Nylon Bearing and the Aerator Axle before each use.
- To prevent rust on Plugging Spoons, apply a light coat of oil on the working areas of Spoons after each use.
- Periodically check the Spoons - remove any debris which might build up and restrict their action.
- After each use, service unit as described - and store in a dry area, shielding tines to avoid injury.

LAWN AERATOR

Model Number 757.243481

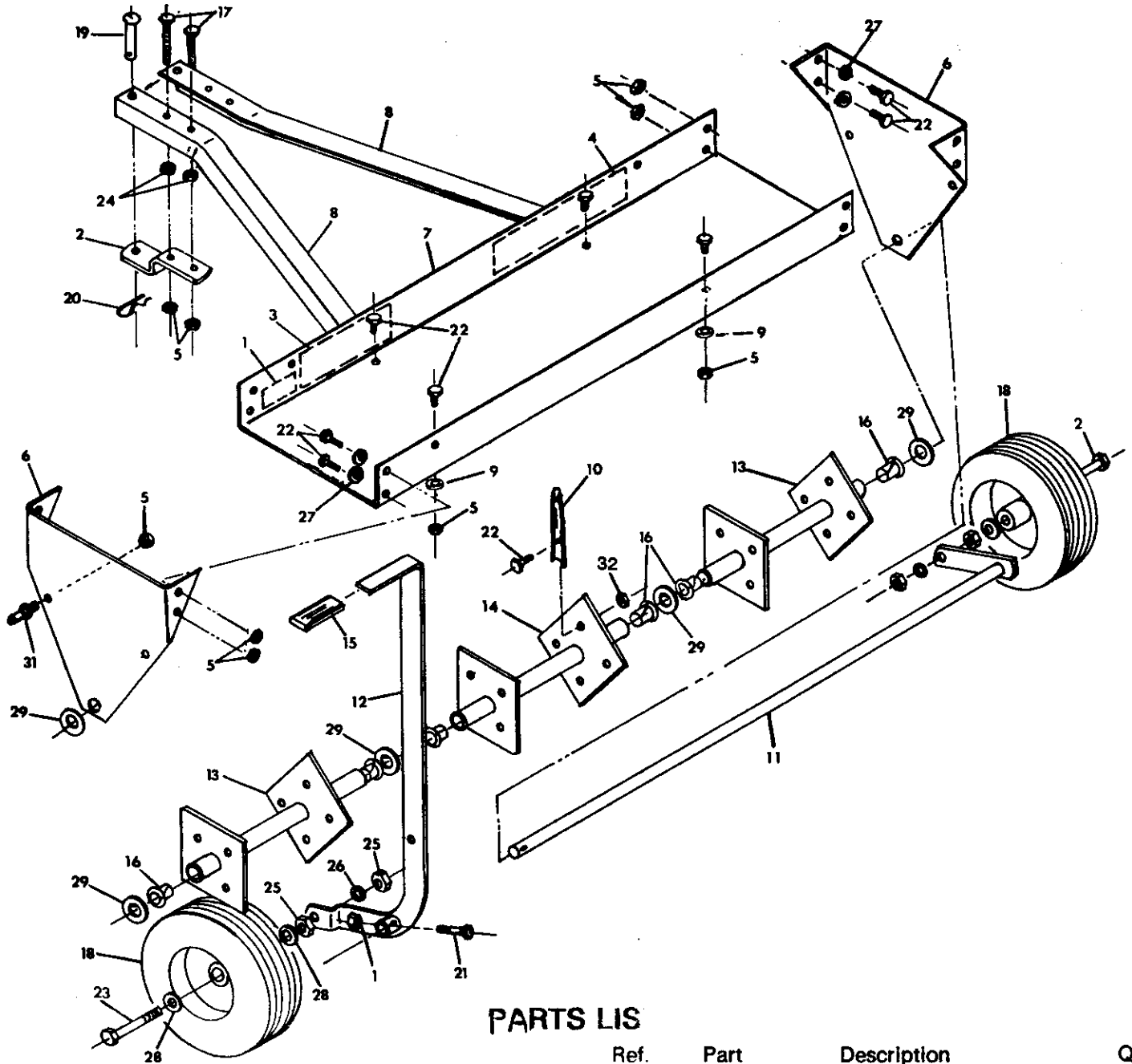

PARTS LIST

Ref. No.	Part No.	Description	Qty.	Ref. No.	Part No.	Description	Qty.
				16	B-4866	3/4" Nylon Bearing	6
				17	B-4868	Hex Bolt- 5/16x2-1/2"	2
				18	B-4869	Transport Wheel	2
				19	B-4870-01	Drawbar Pin	1
				20	D-146P	Hair Pin Cotter	1
				21	2M1024P	Hex Bolt, 5/16"x1-1/2"	1
				22	2M1012P	Hex Bolt- 5/16"x3/4"	38
				23	2M1660P	Hex Bolt- 1/2"x3-3/4"	2
				24	30M1000P	Hex Nut- 5/16"	2
				25	30M1600P	Hex Nut- 1/2"	4
				26	40M1600P	Lock Washer- 1/2"	2
				27	45M1111P	Flat Washer- 5/16"	8
				28	45M1717P	Flat Washer- 1/2"	4
				29	B-676P	Flat Washer- 3/4"	5
				30	L-1590-SC-2	Instructions	1
				31	B-3307-S	Transport Lock Pin	1
				32	B-1674P	Hex Lock Nut- 5/16"	25
1	B-5429	Model No. Decal	1				
2	B-3034-10	Drawbar Clevis	1				
3	B-3568-A	Caution Label	1				
4	B-3686	Logo Decal	1				
5	B-4786	Lock Nut- 5/16"	17				
6	B-4851-10	Side Plate	2				
7	B-5426-10	Tray	1				
8	B-5427-10	Frame Angle	2				
9	R-618	5/16" Heavy Washer	4				
10	B-4855-10	Plugging Spoon	24				
11	B-5307-10	Axle Assembly	1				
12	B-4859-10	Lift Handle Assembly	1				
13	B-5309-10	Outer Tube Assembly	2				
14	B-5311-10	Center Tube Assembly	1				
15	B-4867	Handle Grip	1				

L-1590-SC-2