

NordicTrack

ADVENTURER

Model No. NTHK99902 / ⁸³¹29897
Serial No. _____

Find the serial number in the location shown below. Write the serial number in the space above for reference.

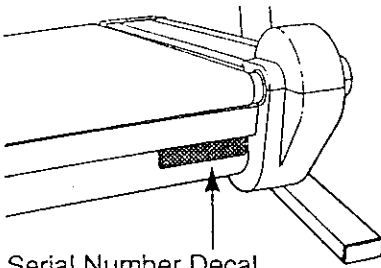

Serial Number Decal

QUESTIONS?

As a manufacturer, we are committed to providing complete customer satisfaction. If you have questions, or if there are missing parts, we will guarantee complete satisfaction through direct assistance from our factory.

TO AVOID UNNECESSARY DELAYS, PLEASE CALL DIRECT TO OUR TOLL-FREE CUSTOMER HOT LINE. The trained technicians on our Customer Hot Line will provide immediate assistance, free of charge to you.

CUSTOMER HOT LINE:

1-888-825-2588

Mon.-Fri., 6 a.m.-6 p.m. MST

⚠ CAUTION

Read all precautions and instructions in this manual before using this equipment. Save this manual for future reference.

USER'S MANUAL

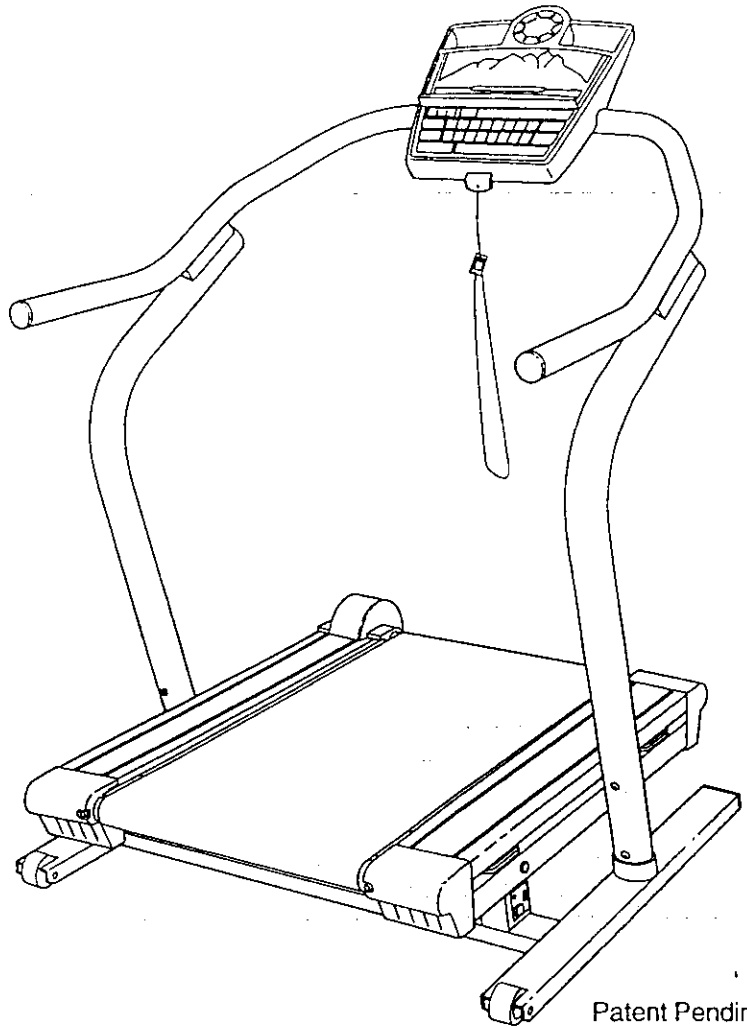

Patent Pending



Visit our website at

www.nordictrack.com

*new products, prizes,
fitness tips, and much more!*



NordicTrack[®]

ADVENTURER

Table of Contents

IMPORTANT PRECAUTIONS3
BEFORE YOU BEGIN5
ASSEMBLY6
OPERATION AND ADJUSTMENT8
HOW TO MOVE THE TREKKER20
TROUBLE-SHOOTING20
CONDITIONING GUIDELINES23
ORDERING REPLACEMENT PARTS	Back Cover
LIMITED WARRANTY	Back Cover

Note: An EXPLODED DRAWING and a PART LIST are attached in the center of this manual. Save the EXPLODED DRAWING and the PART LIST for reference.

Important Precautions

⚠ WARNING: To reduce the risk of burns, fire, electric shock, or injury to persons, read the following important precautions and information before operating the TREKKER.

1. It is the responsibility of the owner to ensure that all users of the TREKKER are adequately informed of all warnings and precautions.
2. Use the TREKKER only as described in this manual.
3. The TREKKER is intended for in-home use only. Do not use the TREKKER in any commercial, rental, or institutional setting.
4. Place the TREKKER on a level surface, with at least eight feet of clearance behind it. Do not place the TREKKER on any surface that blocks air openings. To protect the floor or carpet from damage, cover the floor under the TREKKER.
5. Keep the TREKKER indoors, away from moisture and dust. Do not put the TREKKER in a garage or covered patio, or near water.
6. Do not operate the TREKKER where aerosol products are used or where oxygen is being administered.
7. Do not operate the TREKKER until it is properly assembled. (See ASSEMBLY on page 6.) You must be able to safely lift 45 pounds (20 kg) in order to move the TREKKER.
8. Keep children under the age of 12 and pets away from the TREKKER at all times.
9. The TREKKER should not be used by persons weighing more than 300 pounds.
10. Never allow more than one person on the TREKKER at a time.
11. Wear appropriate exercise clothing when using the TREKKER. Do not wear loose clothing that could become caught in the TREKKER. Athletic support clothes are recommended for both men and women. Always wear athletic shoes. Never use the TREKKER with bare feet, wearing only stockings, or in sandals.
12. When connecting the power cord (see page 8), plug the power cord into a surge suppressor (not included) and plug the surge suppressor into a grounded circuit capable of carrying 15 or more amps. No other appliance should be on the same circuit. Do not use an extension cord.
13. Use only a single-outlet surge suppressor that is UL 1449 listed as a transient voltage surge suppressor (TVSS). The surge suppressor must have a UL suppressed voltage rating of 400 volts or less and a minimum surge dissipation of 450 joules. The surge suppressor must be electrically rated for 120 volts AC and 15 amps. To purchase a surge suppressor, see your local NordicTrack dealer or call 1-888-825-2588 and order part number 146148.
14. Keep the power cord and the surge suppressor away from heated surfaces.
15. The roller guards must be 1/8 inch from the rear roller (the location of the roller guards is shown on page 5). Unplug the power cord and adjust the roller guards, if necessary.
16. Never move the walking belt while the power is turned off. Do not operate the TREKKER if the power cord or plug is damaged, or if the TREKKER is not working properly. (See BEFORE YOU BEGIN on page 5 if the TREKKER is not working properly.)
17. Never start the TREKKER while you are standing on the walking belt. Always hold the handrails while using the TREKKER.
18. The TREKKER is capable of high speeds. Adjust the speed in small increments to avoid sudden jumps in speed.
19. The heart rate monitor is not a medical device. Various factors, including the user's movement, may affect the accuracy of heart rate readings. The heart rate monitor is intended only as an exercise aid in determining heart rate trends in general.
20. Never leave the TREKKER unattended while it is running. Remove the key, unplug the power cord, and move the on/off switch to the off position when the TREKKER is not in use. (The location of the on/off switch is shown on page 5.)
21. Do not change the grade of the TREKKER by placing objects under it.

22. Never insert or drop any object into any opening.
23. When using iFIT.com CD's and videocassettes, an electronic "chirping" sound will alert you when the grade and/or speed of the TREKKER is about to change. Always listen for the "chirp" and be prepared for grade and/or speed changes. In some instances, the grade and/or speed may change before the personal trainer describes the change.
24. When using iFIT.com CD's and videocassettes, you can manually override the grade and speed settings by pressing the grade and speed buttons. However, when the next "chirp" is heard, the grade and/or speed will change to the next settings of the CD or video program.

25. Always remove iFIT.com CD's and videocassettes from your CD player or VCR when they are not in use.
26. Inspect and tighten all parts of the TREKKER regularly.
27. **DANGER:** Always unplug the power cord immediately after use, before cleaning the TREKKER, and before performing the maintenance and adjustment procedures described in this manual. Never remove the motor cover unless instructed to do so by an authorized service representative. Servicing other than the procedures in this manual should be performed by an authorized service representative only.

WARNING: Before beginning this or any exercise program, consult your physician. This is especially important for persons over the age of 35 or persons with pre-existing health problems. Read all instructions before using. ICON assumes no responsibility for personal injury or property damage sustained by or through the use of this product.

SAVE THESE INSTRUCTIONS

The decal shown at the right has been placed on the TREKKER in the two indicated locations. If the decal in either location is missing or illegible, call our Customer Service Department toll-free to order a free replacement decal (see ORDERING REPLACEMENT PARTS on the back cover of this manual). Apply the decal in the location shown.

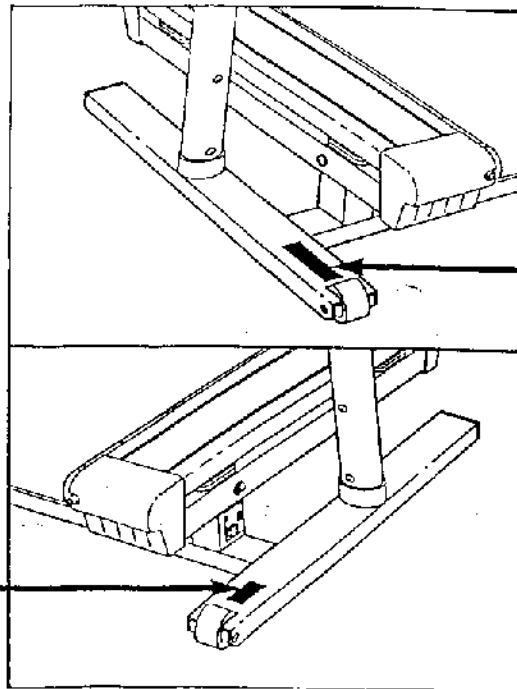

WARNING

Protect yourself and others from risk of serious injury. Read the user's manual and:



*Stand only on the side rails when starting or stopping treadmill.

*Change speed in small increments.

*Hold handrails to prevent falling, and always wear the safety clip while operating treadmill.

*Stop if you feel faint, dizzy, or short of breath.



*Never allow children on or around treadmill.

*Remove key when not in use.

*Keep clothing, jewelry, and hair away from moving belt.



*Never try to adjust or fix the belt while it is moving.

*Always wear athletic shoes while operating treadmill.

CAUTION

KEEP HANDS AND FEET AWAY FROM THIS AREA WHILE THE TREADMILL IS IN OPERATION.

Note: The decal is shown at 52% of actual size.

Before You Begin

Thank you for selecting the revolutionary NordicTrack® ADVENTURER TREKKER™. The ADVENTURER TREKKER combines state-of-the-art technology with innovative design to provide you with an effective form of exercise in the convenience of your home.

For your benefit, read this manual carefully before using the ADVENTURER TREKKER. If you have questions after reading this manual, please call our Customer Service Department toll-free at 1-888-825-

2588, Monday through Friday, 6 a.m. until 6 p.m. Mountain Time (excluding holidays). To help us assist you, please note the product model number and serial number before calling. The product model number is NTHK99902. The serial number can be found on a decal attached to the TREKKER (see the front cover of this manual for the location).

Before reading further, please familiarize yourself with the parts that are labeled in the drawing below.

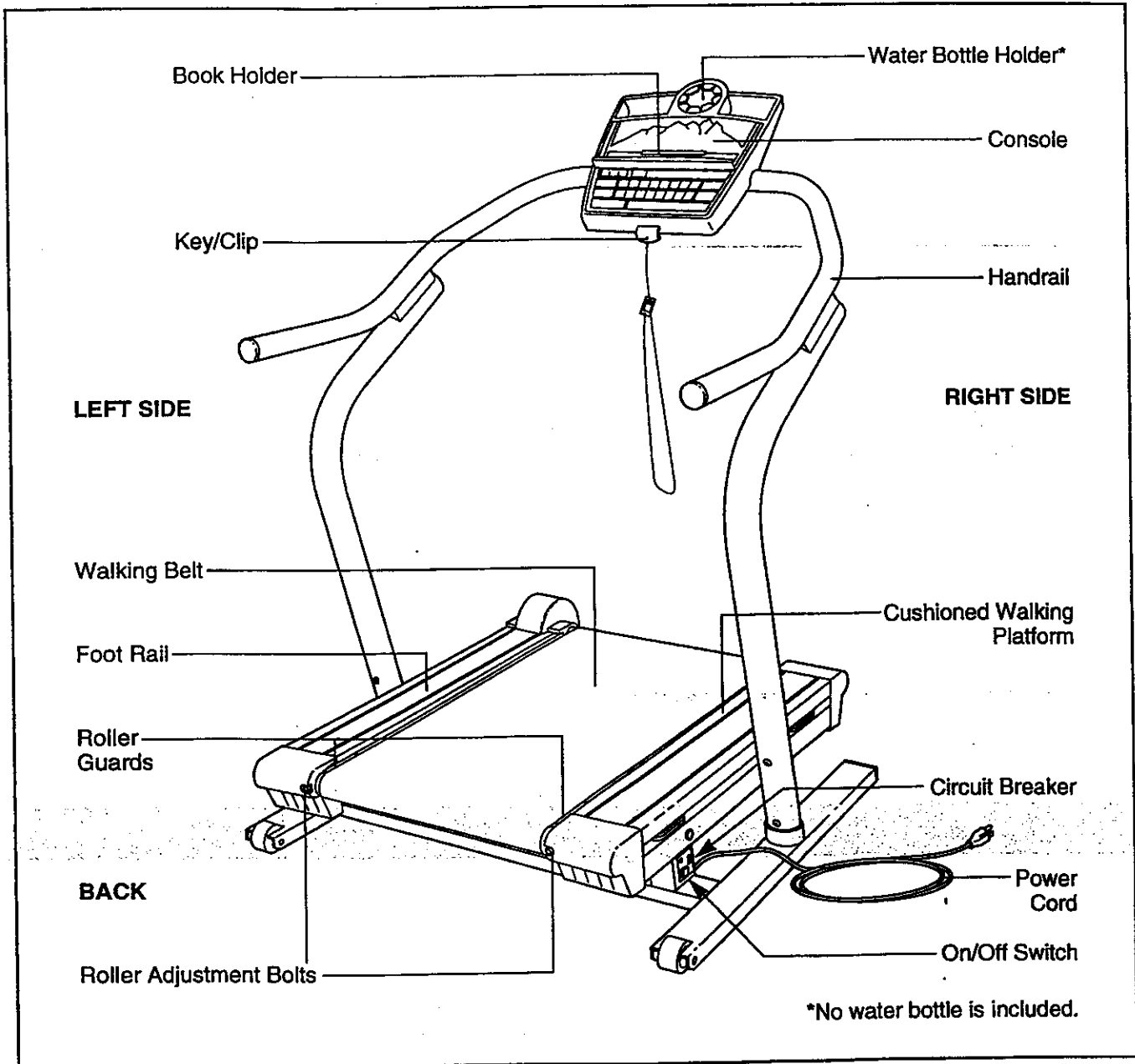

Assembly

Assembly requires two people. Set the TREKKER in a cleared area and remove all packing materials. Do not dispose of the packing materials until assembly is completed. **Assembly requires the included allen wrench and your own Phillips screwdriver** 

Note: The underside of the walking belt is coated with high-performance lubricant. During shipping, a small amount of lubricant may be transferred to the top of the walking belt or the shipping carton. This is a normal condition and does not affect performance. If there is lubricant on top of the walking belt, simply wipe off the lubricant with a soft cloth and a mild, non-abrasive cleaner.

1. Identify the right Upright (23), which has the Upright Wire Harness (100) inside of it. Slide an Upright Collar (54) onto the Upright.

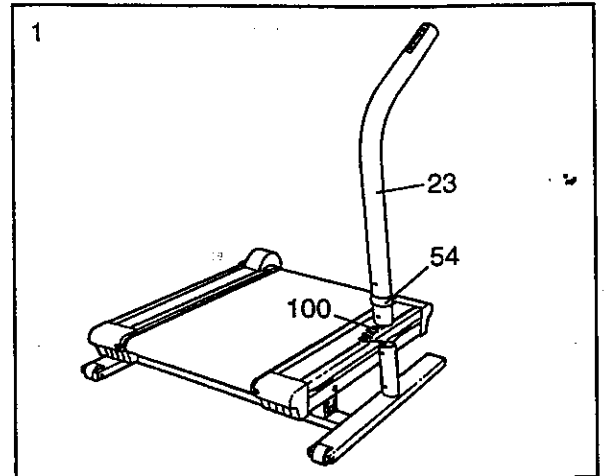

2. If there are three Upright Bolts (33) in the right post on the Base (101), remove them.

While a second person holds the right Upright (23) in the position shown, connect the Upright Wire Harness (100) to the Base Wire Harness (41) in the right post on the Base (101). Insert both Wire Harnesses into the post.

Make sure that the right Upright (23) is in the position shown in drawing 1. Slide the Upright onto the right post on the Base (101) and align the indicated holes. **Be careful not to pinch the Wire Harnesses (100, 41).**

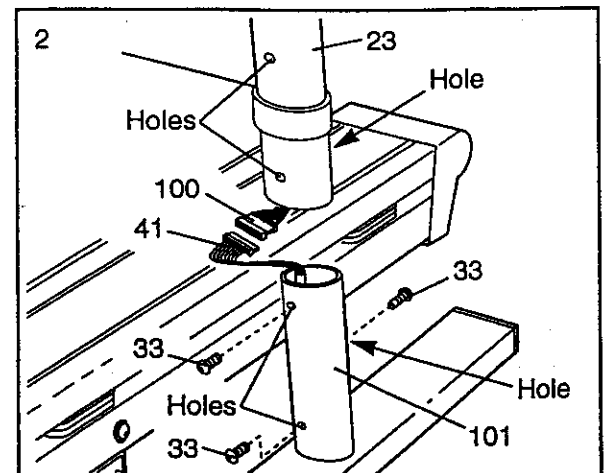

3. Slide the Upright Collar (54) to the position shown. Finger tighten the three Upright Bolts (33) with Upright Washers (32) into the right Upright (23). Note: It may be necessary to move the Upright slightly to align the holes.

Attach the left Upright (not shown) in the same way. Note: There is not a wire harness in the left Upright.

Do not tighten the Upright Bolts (33) yet.

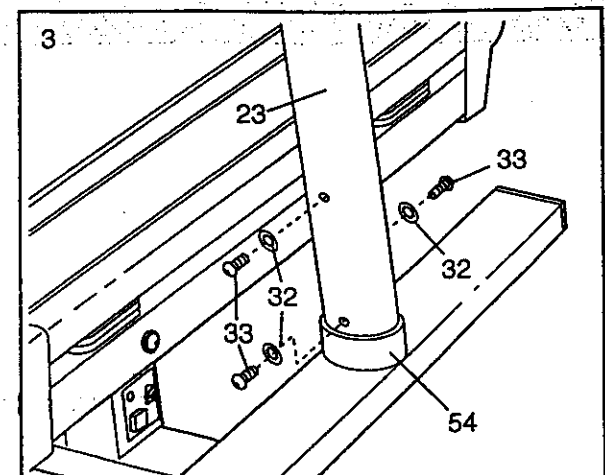

- Set the Console (99) and the Handrail (27) on the floor.

Locate the Handrail Wire Harness (30) in the Handrail (27). While a second person holds the Console (99), connect the 8-pin wire of the Handrail Wire Harness to the HD2 connector on the back of the Console. Next, connect the 4-pin wire to the IFIT2 connector, and the 3-pin wire to the HD1 connector in the location shown.

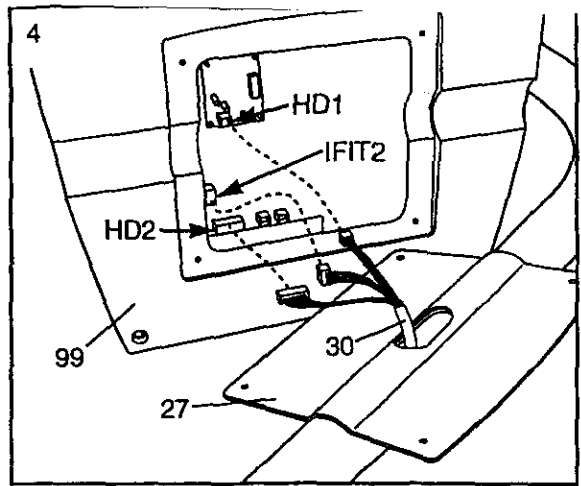

- Attach the Console (99) to the Handrail (27) with the four Small Screws (6). **Make sure that the Handrail Wire Harness (not shown) is not pinched between the Console and the Handrail.**

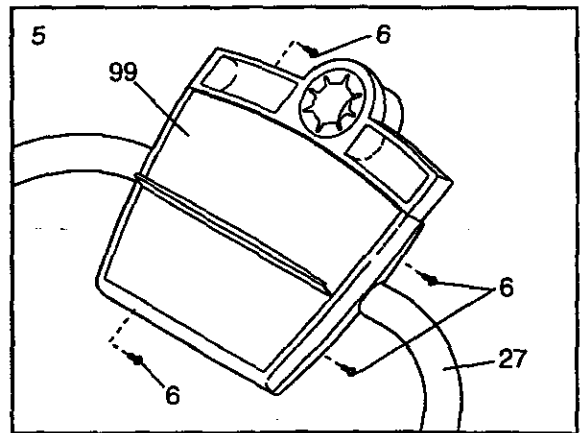

- Place a Handrail Cover (53) on each Upright (23). Make sure that the Handrail Covers are turned as shown in the inset drawing.

Have a second person hold the Handrail (27) in the position shown. Connect the Handrail Wire Harness (30) to the Upright Wire Harness (100). Insert both Wire Harnesses into the right Upright (23).

Hold a Metal Spacer (114) inside the right Upright (23) and align it with the first hole in the Upright. Insert a Handrail Bolt (25) with a Handrail Star Washer (26) through the Upright and the Metal Spacer. Hold the Handrail (27) above the Handrail Covers (53) and finger tighten the Handrail Bolt into the Handrail. Repeat this procedure on the left side. Then, tighten the two remaining Handrail Bolts with Handrail Star Washers into the Handrail. **Be careful not to pinch the wires.**

Tighten all of the bolts used in steps 3 and 6. Press the Large Endcaps (86) into the Uprights (23).

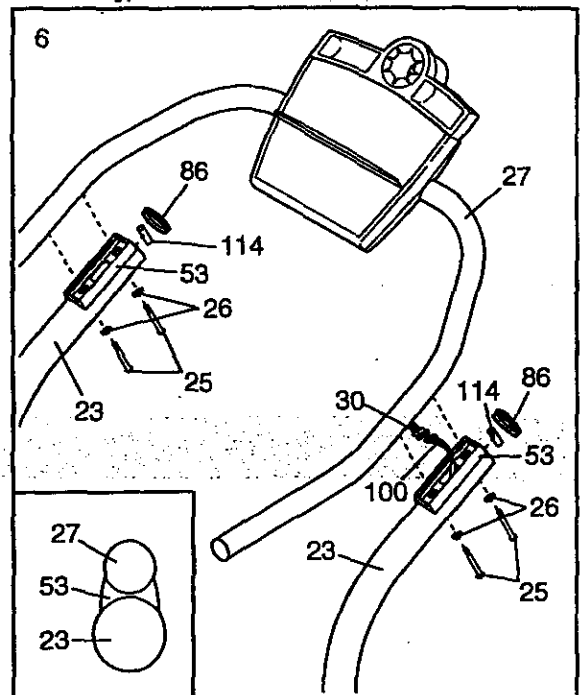

- Make sure that all parts are tightened before you use the TREKKER.** Keep the included allen wrench in a secure place. The allen wrench is used to adjust the walking belt (see page 22). To protect the floor or carpet from damage, cover the floor under the TREKKER.

Operation and Adjustment

THE PERFORMANT LUBE™ WALKING BELT

Your TREKKER features a walking belt coated with PERFORMANT LUBE™, a high-performance lubricant. **IMPORTANT:** Never apply silicone spray or other substances to the walking belt or the walking platform. Such substances will deteriorate the walking belt and cause excessive wear.

HOW TO PLUG IN THE POWER CORD

⚠ DANGER: Improper connection of the equipment-grounding conductor can result in an increased risk of electric shock. Check with a qualified electrician or serviceman if you are in doubt as to whether the product is properly grounded. Do not modify the plug provided with the product—If it will not fit the outlet, have a proper outlet installed by a qualified electrician.

Your TREKKER, like any other type of sophisticated electronic equipment, can be seriously damaged by sudden voltage changes in your home's power. Voltage surges, spikes, and noise interference can result from weather conditions or from other appliances being turned on or off. **To decrease the possibility of your TREKKER being damaged, always use a surge suppressor with your TREKKER (see drawing 1 at the right).**

To purchase a surge suppressor, see your local NordicTrack dealer or call 1-888-825-2588 and order part number 146148. Use only a single-outlet surge suppressor that is UL 1449 listed as a transient voltage surge suppressor (TVSS). The surge suppressor must have a UL suppressed voltage rating of 400 volts or less and a minimum surge dissipation of 450 joules. The surge suppressor must be electrically rated for 120 volts AC and 15 amps.

This product must be grounded. If it should malfunction or break down, grounding provides a path of least resistance for electric current to reduce the risk of electric shock. This product is equipped with a cord having an equipment-grounding conductor and a grounding plug. **Plug the power cord into a surge suppressor, and plug the surge suppressor into an appropriate outlet that is properly installed and grounded in accordance with all local codes and ordinances. Important: The TREKKER is not compatible with GFCI-equipped outlets.**

This product is for use on a nominal 120-volt circuit, and has a grounding plug that looks like the plug illustrated in drawing 1 below. A temporary adapter that looks like the adapter illustrated in drawing 2 may be used to connect the surge suppressor to a 2-pole receptacle as shown in drawing 2 if a properly grounded outlet is not available.

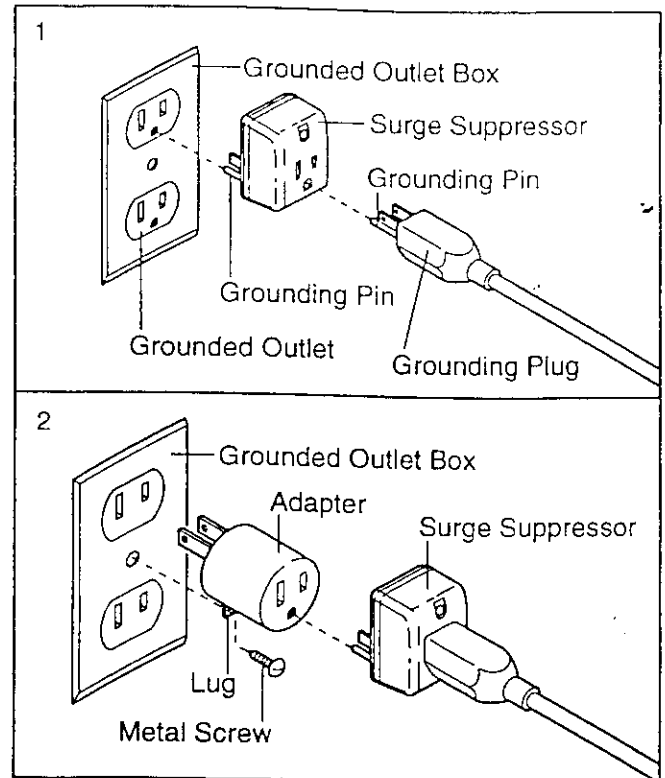

The temporary adapter should be used only until a properly grounded outlet (drawing 1) can be installed by a qualified electrician.

The green-colored rigid ear, lug, or the like extending from the adapter must be connected to a permanent ground such as a properly grounded outlet box cover. Whenever the adapter is used it must be held in place by a metal screw. **Some 2-pole receptacle outlet box covers are not grounded. Contact a qualified electrician to determine if the outlet box cover is grounded before using an adapter.**

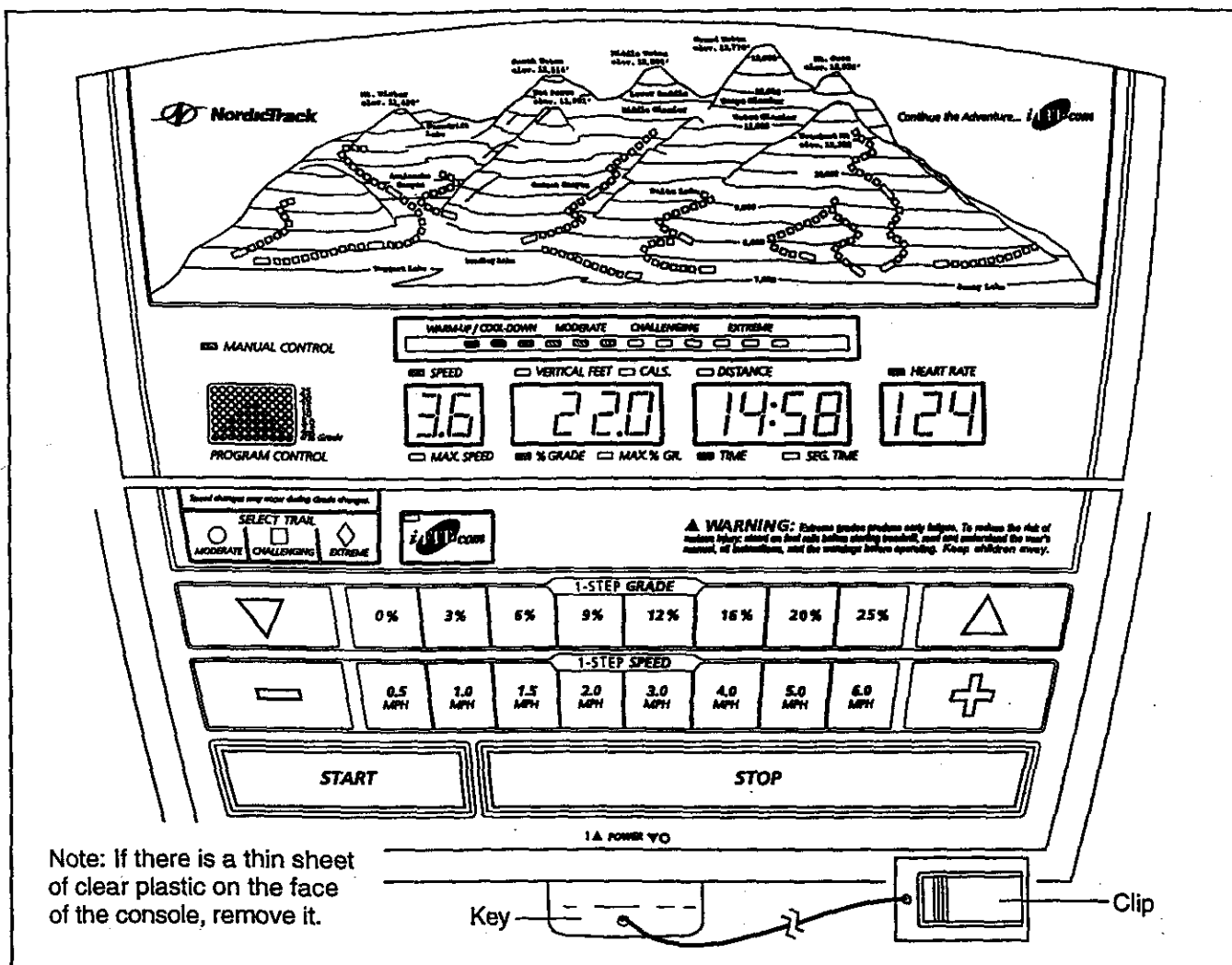

Note: If there is a thin sheet of clear plastic on the face of the console, remove it.

FEATURES OF THE CONSOLE

The revolutionary TREKKER combines state-of-the-art technology with innovative design to provide you with a motivating and effective form of exercise in the convenience of your home.

When the manual mode of the console is selected, the grade and speed of the TREKKER can be changed with a touch of a button. As you exercise, the console will display continuous exercise feedback. You can even track your heart rate using the optional heart rate monitor (for information about the optional heart rate monitor, see page 19).

The console also offers fifteen preset programs. Each preset program automatically controls the grade and speed of the TREKKER to simulate a hiking trail as it guides you through an effective workout. Choose from moderate, challenging, and extreme programs.

The console also features new iFIT.com interactive technology. iFIT.com technology is like having a personal trainer right in your home. Using the included audio cable, you can connect the TREKKER to your

home stereo, portable stereo, or computer and play special iFIT.com CD programs (CD's are available separately). iFIT.com CD programs automatically control the grade and speed of the TREKKER as a personal trainer walks you through every step of your workout. High-energy music provides added motivation. Each CD features two programs designed by certified personal trainers.

In addition, you can connect the TREKKER to your VCR and TV and play iFIT.com video programs (videocassettes are available separately). Video programs offer the same benefits as iFIT.com CD programs, but add the excitement of exercising with a class and an instructor—the hottest new trend at health clubs.

With the TREKKER connected to your computer, you can also go to our new internet site at www.iFIT.com and access audio programs and video programs directly from the internet. And by adding an optional upgrade module to the TREKKER, you can use virtually endless features from our internet site. See www.iFIT.com for complete details. To purchase iFIT.com CD's or videocassettes, call toll-free 1-800-735-0768. To order the optional upgrade module, see page 19.

CAUTION: Before operating the console, read the following precautions.

- Do not stand on the walking belt when turning on the power.
- Always wear the clip (see the drawing below) while operating the TREKKER.
- Adjust the speed in small increments to avoid sudden jumps in speed.
- To reduce the possibility of electric shock, keep the console dry. Avoid spilling liquids on the console and place only a sealed water bottle in the water bottle holder.

GETTING STARTED

- 1** Attach the clip to the waistband of your clothing.

Stand on the foot rails of the TREKKER.

Find the clip attached to the key and slide the clip onto the waistband of your clothing. Next, insert the key into the console.

Test the clip by carefully taking a few steps backward until the key is pulled from the console. If the key is not pulled from the console, adjust the position of the clip as needed. Then, remove the key from the console.

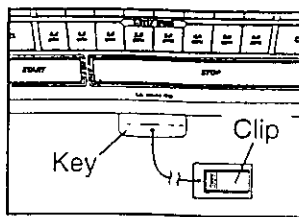

- 2** Plug in the power cord.

See HOW TO PLUG IN THE POWER CORD on page 8.

- 3** Move the on/off switch to the on position.

Locate the on/off switch on the TREKKER near the power cord. Move the on/off switch to the on position.

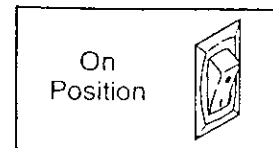

- 4** Insert the key fully into the console.

Stand on the foot rails of the TREKKER. Attach the clip securely to the waistband of your clothing.

Next, insert the key into the console. After a moment, various displays and indicators on the console will light. Note: When the key is inserted, the TREKKER may automatically calibrate itself by rising to the highest grade and then returning to the lowest grade. If this occurs, the console will show two dashes (--) and one flashing indicator while the TREKKER calibrates itself.

To use the manual mode of the console, follow the steps beginning on page 11. To use a preset program, see page 12. To use an iFIT.com CD or video program, see page 16. To use an iFIT.com program directly from our internet site, see page 18.

HOW TO USE THE MANUAL MODE

1 Insert the key fully into the console.

See GETTING STARTED on page 10.

2 Select the manual mode.

When the key is inserted, the manual mode will automatically be selected, as shown by the Manual Control indicator. If a preset program has been selected, press the Moderate, Challenging, or Extreme button repeatedly until the Manual indicator lights.

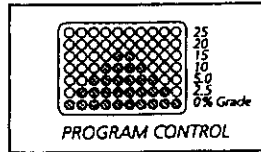

3 Press the Start button or the Speed + button to start the walking belt.

A moment after the button is pressed, the walking belt will begin to move at 1 mile per hour. Hold the handrails and begin walking.

As you exercise, change the speed of the walking belt as desired by pressing the Speed + and - buttons. Each time a button is pressed, the speed setting will change by 0.1 mph; if a button is held down, the speed setting will change in increments of 0.5 mph. To change the speed setting quickly, press the 1-step Speed buttons. The speed range is 0.5 mph to 6 mph. Note: After the buttons are pressed, it will take a moment for the walking belt to reach the selected speed setting.

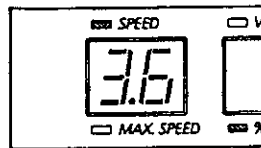

To stop the walking belt, press the Stop button. The displays will pause and the Distance/Time display will begin to flash. To restart the walking belt, press the Start button or the Speed + button.

4 Change the grade of the TREKKER as desired.

To change the grade of the TREKKER, press the Grade Δ or ∇ button. Each time a button is pressed, the grade will change by 1%. To change the grade quickly, press the 1-step Grade buttons. The grade range is 0% to 25%. Note: After the buttons are pressed, it will take a moment for the TREKKER to reach the selected grade setting.

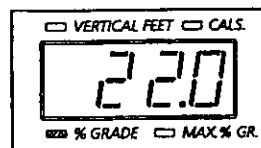

5 Follow your progress with the console displays.

The matrix—When the manual mode or an iFIT.com program is selected, the matrix will display a triangle representing a mountain. When the walking belt is started, the triangle will disappear except for one flashing indicator. As you exercise, the indicators in the triangle will light one at a time until the entire triangle is again lit. This cycle will then repeat. Each time the entire triangle lights, you have walked 1/4 mile.

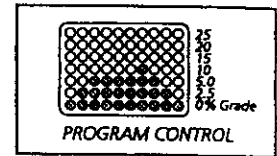

The exercise intensity display—

As you exercise, the row of indicators below the trail display will show the intensity level of your exercise. For example, if four to six indicators are lit, your intensity level is equal to a moderate hike.

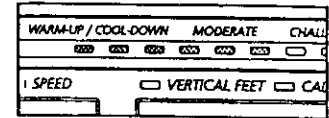

The Speed display—This display shows the speed of the walking belt.

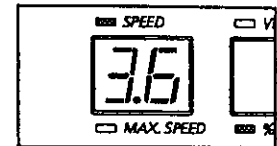

Note: The console can display speed and distance in either miles or kilometers. To see which unit of measurement is selected, hold down the Stop button while inserting the key into the console. An "E" for English miles or an "M" for metric kilometers will appear in the Speed display. Press the Speed + button to change the unit of measurement. When the desired unit of measurement is selected, remove the key and then re-insert it. Note: For simplicity, all instructions in this manual refer to miles.

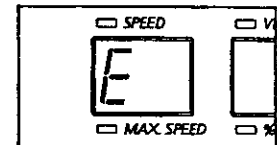

The Vertical Feet/Cals./Grade display—

This display shows the number of vertical feet you have climbed, the grade of the TREKKER, and the approximate number of calories you have burned. The display will change from one number to the next every seven seconds, as shown by the indicators around the display.

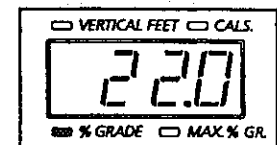

The Distance/Time display—When the manual mode or an iFIT.com program is selected, this display will show the distance you have hiked and the elapsed time. The distance will be shown for seven seconds and the time will be shown for fourteen seconds, as shown by the indicators around the display.

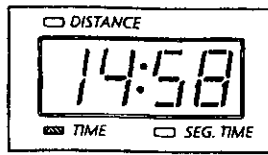

When a preset program is selected, the Distance/Time display will show the distance you have hiked, the time remaining in the program, and the time remaining in the current segment of the program.

Pulse display—This display will show your heart rate when the optional heart rate monitor is worn. (For information about the optional heart rate monitor, see page 19.)

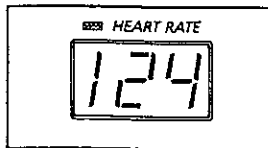

To reset the displays, press the Stop button, remove the key, and then re-insert the key.

6 When you are finished exercising, stop the walking belt and remove the key.

Step onto the foot rails and press the Stop button. Next, remove the key from the console and put it in a secure place. **Note: If the displays and indicators on the console remain lit after the key is removed, the console is in the “demo” mode. Refer to page 19 and turn off the demo mode.**

When you are finished using the TREKKER, move the on/off switch near the power cord to the off position and unplug the power cord.

HOW TO USE PRESET PROGRAMS

The console offers fifteen preset programs. Each preset program automatically controls the grade and speed of the TREKKER to simulate a hiking trail as it guides you through an effective workout. You can choose from five moderate programs, five challenging programs, and five extreme programs.

Follow the steps below to use a preset program.

1 Insert the key fully into the console.

See GETTING STARTED on page 10.

2 Select the desired preset program.

When the key is inserted, the manual mode will be selected. To select one of the five moderate programs, press the Moderate button repeatedly; to select a challenging program, press the Challenging button repeatedly; to select an extreme program, press the Extreme button repeatedly. The

fifteen trails shown in the trail display represent the fifteen preset programs. As

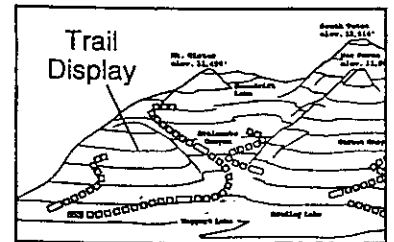

you press the Moderate, Challenging, or Extreme button repeatedly, indicators will light in the trail display to show which trail you have selected.

When a preset program is selected, the matrix will show the grade settings for the program. (For the

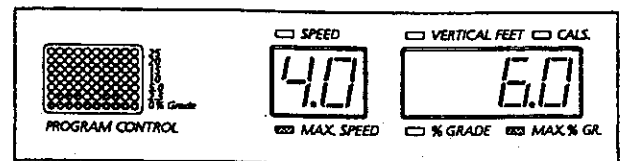

longest programs, the matrix will not show all of the grade settings at once.) In addition, the Speed display will show the maximum speed setting for the program and the Vertical Feet/Cals./Grade display will show the maximum grade setting for the program.

3 Press the Start button or the Speed + button to start the program.

A moment after the button is pressed, the TREKKER will automatically adjust to the first grade and speed settings for the program. Hold the handrails and begin walking.

Each program is divided into several time segments of different lengths. The Distance/Time display shows both the time remaining in the program and the time remaining in the current segment of the program. One grade setting and one speed setting are programmed for each segment. The grade setting for the first segment is shown in the flashing Current Segment column of the matrix. (The speed settings are not shown in the matrix.) The grade settings for upcoming segments are shown in the columns to the right.

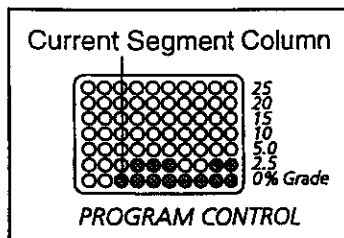

When only three seconds remain in the first segment of the program, both the Current Segment column and the column to the right will flash and a series of tones will sound. In addition, the Speed display will flash three times if the speed is about to change, and the Vertical Feet/Cals./Grade display will flash if the grade is about to change. When the first segment is completed, *all grade settings in the matrix will move one column to the left.* The grade setting for the second segment will then be shown in the flashing Current Segment column and the TREKKER will automatically adjust to the grade and speed settings for the second segment.

The program will continue until the grade setting for the last segment is shown in the Current Segment column of the matrix and no time remains in the program. The walking belt will then slow to a stop.

If the grade or speed setting for the current segment is too high or too low, you can manually override the setting by pressing the Grade or Speed buttons on the console. Every few times one of the Grade buttons is pressed, an additional indicator will light or darken in the Current Segment column of the matrix. **Important: If you manually override the grade or speed setting for the current segment, when the segment ends the TREKKER will automatically adjust to the grade and speed settings for the next segment.** Note: Because each program is based on a preset distance, if you manually increase the speed, the time remaining in the current segment and the time remaining in the program will decrease; if you manually decrease the speed, the time remaining in the current segment and the time remaining in the program will increase.

To stop the program temporarily, press the Stop button. The displays will pause and the Distance/Time display will begin to flash. To restart the program, press the Start button or the Speed + button. To end the program, press the Stop button, remove the key, and then re-insert the key. Pressing the Moderate, Challenging, or Extreme button will also end the program and will select the next preset program or the manual mode.

4 Follow your progress with the displays.

See step 5 on page 11.

5 When the program is completed, remove the key.

Step onto the foot rails and remove the key from the console. Make sure to keep the key in a secure place. **Note: If the displays and indicators on the console remain lit after the key is removed, the console is in the "demo" mode. Refer to page 19 and turn off the demo mode.**

When you are finished using the TREKKER, move the on/off switch near the power cord to the off position and unplug the power cord.

HOW TO CONNECT THE TREKKER TO YOUR CD PLAYER, VCR, OR COMPUTER

To use iFIT.com CD's, the TREKKER must be connected to your portable CD player, portable stereo, home stereo, or computer with CD player. See this page and page 15 for connecting instructions. To use iFIT.com videocassettes, the TREKKER must be connected to your VCR. See page 16 for connecting instructions. To use iFIT.com programs directly from our internet site, the TREKKER must be connected to your home computer. See page 15 for connecting instructions.

HOW TO CONNECT YOUR PORTABLE CD PLAYER

Note: If your CD player has separate LINE OUT and PHONES jacks, see instruction A below. If your CD player has only one jack, see instruction B.

- A. Plug one end of the audio cable into the jack on the side of the TREKKER near the power cord. Plug the other end of the cable into the LINE OUT jack on your CD player. Plug your headphones into the PHONES jack.

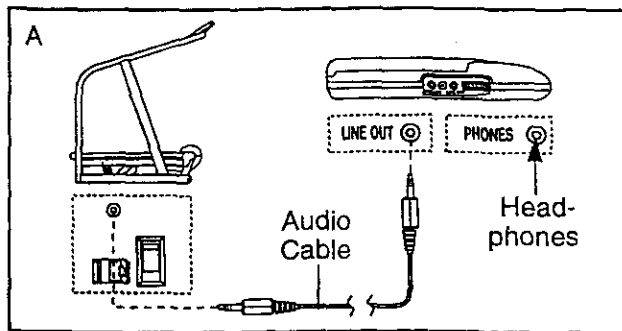

- B. Plug one end of the audio cable into the jack on the side of the TREKKER near the power cord. Plug the other end of the cable into a 3.5mm Y-adapter (available at electronics stores). Plug the Y-adapter into the PHONES jack on your CD player. Plug your headphones into the other side of the Y-adapter.

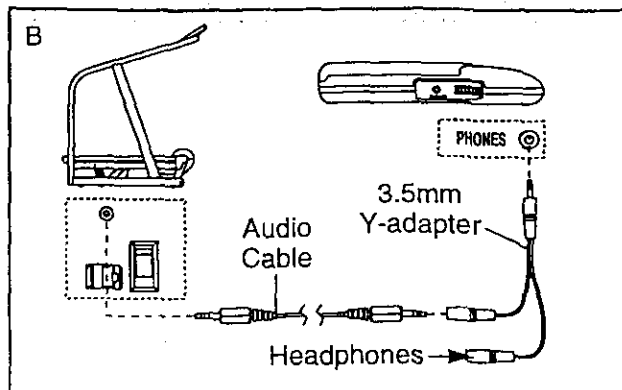

HOW TO CONNECT YOUR PORTABLE STEREO

Note: If your stereo has an RCA-type AUDIO OUT jack, see instruction A below. If your stereo has a 3.5mm LINE OUT jack, see instruction B. If your stereo has only a PHONES jack, see instruction C.

- A. Plug one end of the audio cable into the jack on the side of the TREKKER near the power cord. Plug the other end of the cable into the included adapter. Plug the adapter into an AUDIO OUT jack on your stereo.

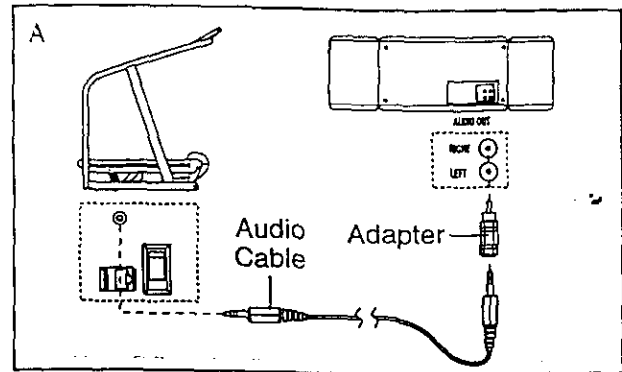

- B. Plug one end of the audio cable into the jack on the side of the TREKKER near the power cord. Plug the other end of the cable into the LINE OUT jack on your stereo.

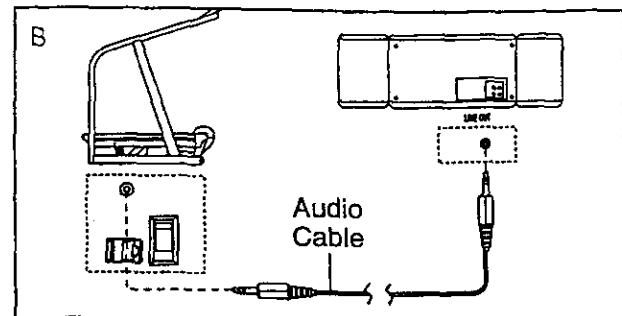

- C. Plug one end of the audio cable into the jack on the side of the TREKKER near the power cord. Plug the other end of the cable into a 3.5mm Y-adapter (available at electronics stores). Plug the Y-adapter into the PHONES jack on your stereo. Plug your headphones into the other side of the Y-adapter.

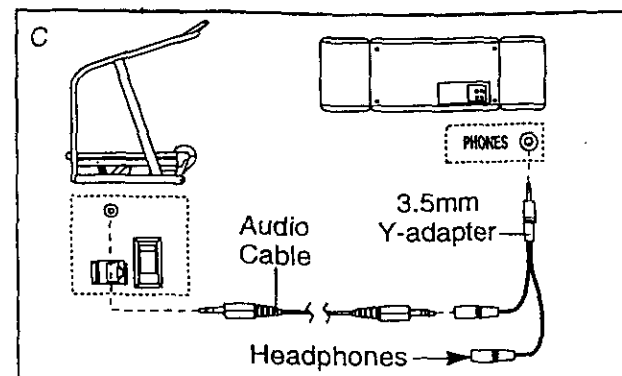

HOW TO CONNECT YOUR HOME STEREO

Note: If your stereo has an unused LINE OUT jack, see instruction A below. If the LINE OUT jack is being used, see instruction B.

- A. Plug one end of the audio cable into the jack on the side of the TREKKER near the power cord. Plug the other end of the cable into the included adapter. Plug the adapter into the LINE OUT jack on your stereo.

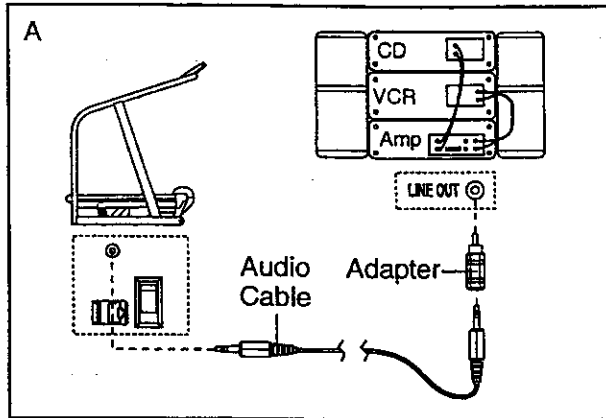

- B. Plug one end of the audio cable into the jack on the side of the TREKKER near the power cord. Plug the other end of the cable into the included adapter. Plug the adapter into an RCA Y-adapter (available at electronics stores). Next, remove the wire that is currently plugged into the LINE OUT jack on your stereo and plug the wire into the unused side of the RCA Y-adapter. Plug the RCA Y-adapter into the LINE OUT jack on your stereo.

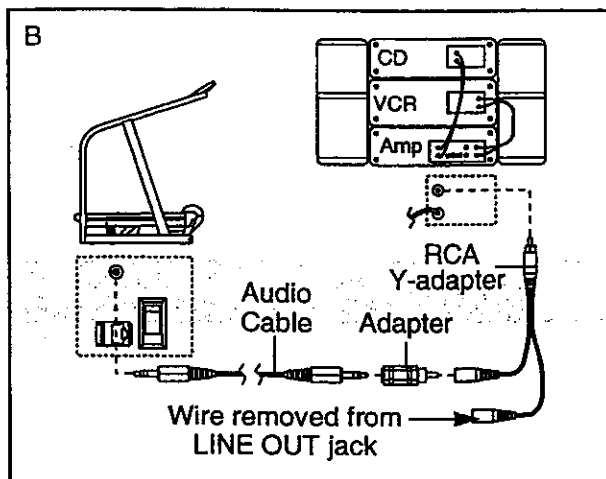

HOW TO CONNECT YOUR COMPUTER

Note: If your computer has a 3.5mm LINE OUT jack, see instruction A. If your computer has only a PHONES jack, see instruction B.

- A. Plug one end of the audio cable into the jack on the side of the TREKKER near the power cord. Plug the other end of the cable into the LINE OUT jack on your computer.

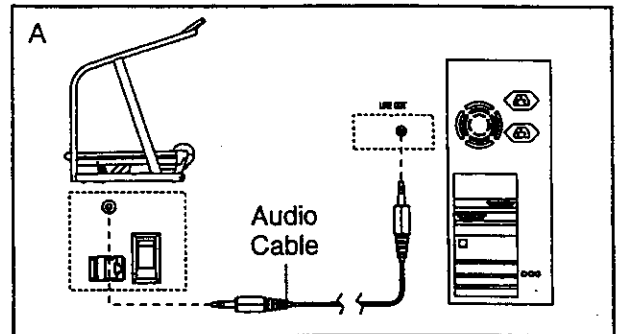

- B. Plug one end of the audio cable into the jack on the side of the TREKKER near the power cord. Plug the other end of the cable into a 3.5mm Y-adapter (available at electronics stores). Plug the Y-adapter into the PHONES jack on your computer. Plug your headphones or speakers into the other side of the Y-adapter.

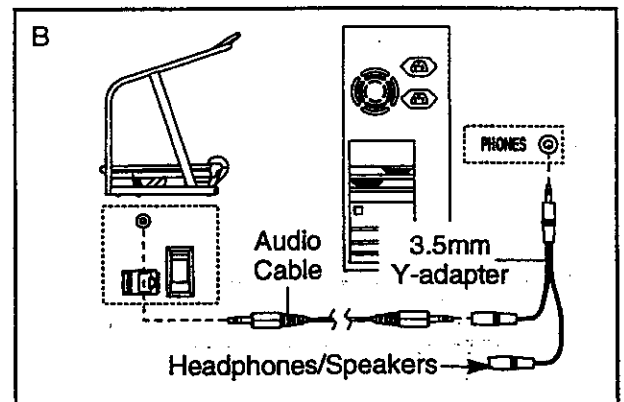

HOW TO CONNECT YOUR VCR

Note: If your VCR has an unused AUDIO OUT jack, see instruction A below. If the AUDIO OUT jack is being used, see instruction B. If you have a TV with a built-in VCR, see instruction B. If your VCR is connected to your home stereo, see HOW TO CONNECT YOUR HOME STEREO on page 15.

- A. Plug one end of the audio cable into the jack on the side of the TREKKER near the power cord. Plug the other end of the cable into the included adapter. Plug the adapter into the AUDIO OUT jack on your VCR.

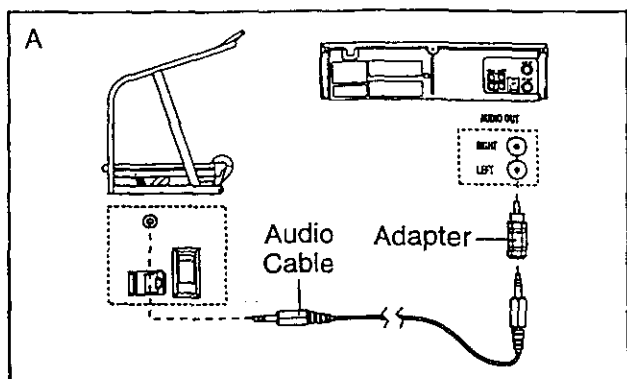

- B. Plug one end of the audio cable into the jack on the side of the TREKKER near the power cord. Plug the other end of the cable into the included adapter. Plug the adapter into an RCA adapter (available at electronics stores). Next, remove the wire that is currently plugged into the AUDIO OUT jack on your VCR and plug the wire into the unused side of the RCA adapter. Plug the RCA adapter into the AUDIO OUT jack on your VCR.

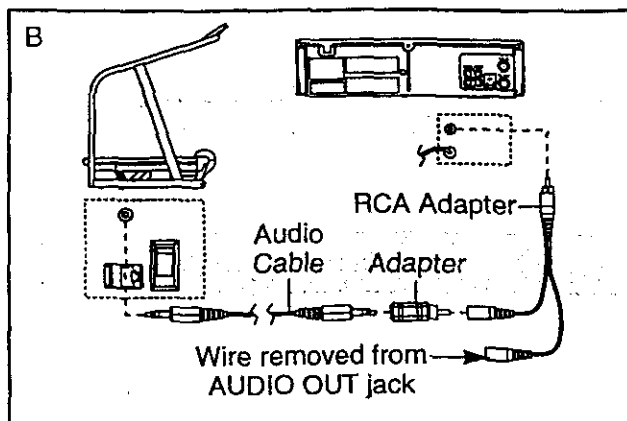

HOW TO USE iFIT.COM CD AND VIDEO PROGRAMS

To use iFIT.com CD's or videocassettes, the TREKKER must be connected to your portable CD player, portable stereo, home stereo, computer with CD player, or VCR. See HOW TO CONNECT THE TREKKER TO YOUR CD PLAYER, VCR, OR COMPUTER on page 14. **Note:** To purchase iFIT.com CD's or videocassettes, call toll-free 1-800-735-0768.

Follow the steps below to use an iFIT.com CD or video program.

1 Insert the key fully into the console.

See GETTING STARTED on page 10.

2 Select the iFIT.com mode.

When the key is inserted, the manual mode will be selected. To use an iFIT.com CD or video program, press the iFIT.com button. The indicator on the button will light.



3 Insert the iFIT.com CD or videocassette.

If you are using an iFIT.com CD, insert the CD into your CD player. If you are using an iFIT.com videocassette, insert the videocassette into your VCR.

4 Press the PLAY button on your CD player or VCR.

A moment after the button is pressed, your personal trainer will begin guiding you through the program. Simply follow your personal trainer's instructions. **Note:** If the Distance/Time display is flashing, press the Start button or the Speed + button on the console. The TREKKER will not respond to a CD or video program when the display is flashing.

During the CD or video program, an electronic "chirping" sound will alert you when the grade and/or speed of the TREKKER is about to change. **CAUTION:** Always listen for the "chirp" and be prepared for grade and/or speed changes. In some instances, the grade and/or speed may change before the personal trainer describes the change.

If the grade or speed settings are too high or too low, you can manually override the settings at any time by pressing the Grade or Speed buttons on the console. However, when the next "chirp" is heard, the speed and/or grade will change to the next settings of the CD or video program.

To stop the walking belt at any time, press the Stop button on the console. The Distance/Time display will begin to flash. To restart the program, press the Start button or the Speed + button. After a moment, the walking belt will begin to move at 1 mph. When the next "chirp" is heard, the grade and speed will change to the next settings of the CD or video program. Pressing the Stop button on your CD player or VCR will also stop the program.

When the CD or video program is completed, the walking belt will stop and the Distance/Time display will begin to flash. Note: To use another CD or video program, press the Stop button or remove the key and go to step 1 on page 16.

Note: If the grade or speed of the TREKKER does not change when a "chirp" is heard:

- make sure that the indicator on the iFIT.com button is lit and that the Distance/Time display is not flashing. If the display is flashing, press the Start button or the Speed + button on the console.
- adjust the volume of your CD player or VCR. If the volume is too high or too low, the console may not detect the program signals.
- make sure that the audio cable is properly connected, that it is fully plugged in, and that it is not wrapped around a power cord.
- if you are using your portable CD player and the CD skips, set the CD player on the floor or another flat surface instead of on the console.

5 Follow your progress with the displays.

See step 5 on page 11.

6 When the program is completed, remove the key.

See step 6 on page 12.

HOW TO USE PROGRAMS DIRECTLY FROM OUR INTERNET SITE

Our new internet site at www.iFIT.com allows you to access a selection of programs that interactively control your TREKKER to help you achieve your specific exercise goals. In addition, you can play iFIT.com audio and video programs directly from the internet. By adding an optional upgrade module to the console, you can use virtually endless features from our internet site. Explore www.iFIT.com for details. **To purchase an upgrade module, see page 19.**

To use programs from our internet site, the TREKKER must be connected to your home computer. See **HOW TO CONNECT YOUR COMPUTER** on page 15. In addition, you must have an internet connection and an internet service provider. A list of specific system requirements will be found on our internet site.

Follow the steps below to use a program from our internet site.

1 Insert the key fully into the console.

See **GETTING STARTED** on page 10.

2 Select the iFIT.com mode.

When the key is inserted, the manual mode will be selected. To use a program from our internet site, press the iFIT.com button. The indicator on the button will light.

3 Go to your computer and start an internet connection.

4 Start your web browser, if necessary, and go to our internet site at www.iFIT.com.

5 Follow the links on our internet site to select a program.

Read and follow the on-line instructions for using a program.

6 Follow the on-line instructions to start the program.

When you start the program, an on-screen countdown will begin.

7 Return to the TREKKER and stand on the foot rails. Find the clip attached to the key and slide the clip onto the waistband of your clothing.

When the on-screen countdown ends, the program will begin and the walking belt will begin to move. Hold the handrails, step onto the walking belt, and begin walking. During the program, an electronic "chirping" sound will alert you when the grade and/or speed of the TREKKER is about to change. **CAUTION: Always listen for the "chirp" and be prepared for grade and/or speed changes.**

If the grade or speed settings are too high or too low, you can manually override the settings at any time by pressing the Grade or Speed buttons on the console. **However, when the next "chirp" is heard, the grade and/or speed will change to the next settings of the program.**

To stop the walking belt at any time, press the Stop button on the console. The Distance/Time display will begin to flash. To restart the program, press the Start button or the Speed + button. After a moment, the walking belt will begin to move at 1 mph. **When the next "chirp" is heard, the grade and speed will change to the next settings of the program.**

When the program is completed, the walking belt will stop and the Distance/Time display will begin to flash. Note: To use another program, press the Stop button and go to step 5.

Note: If the grade or speed of the TREKKER does not change when a "chirp" is heard, make sure that the indicator on the iFIT.com button is lit and that the Distance/Time display is not flashing. In addition, make sure that the audio cable is properly connected, that it is fully plugged in, and that it is not wrapped around a power cord.

8 Follow your progress with the displays.

See step 5 on page 11.

9 When the program is completed, remove the key.

See step 6 on page 12.

THE INFORMATION MODE/DEMO MODE

The console features an information mode that keeps track of the total number of hours that the TREKKER has been operated and the total number of miles that the walking belt has moved. The information mode also allows you to switch the console from miles to kilometers. In addition, the information mode allows you to turn on and turn off the demo mode.

To select the information mode, hold down the Stop button while inserting the key into the console. When the information mode is selected, the console will show the following information:

An "E" for English miles or an "M" for metric kilometers will appear in the Speed display. Press the Speed + button to change the unit of measurement.

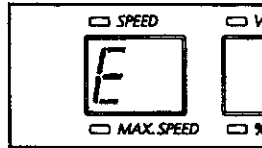

The Vertical Feet/Cals./Grade display will show the total number of miles that the walking belt has moved.

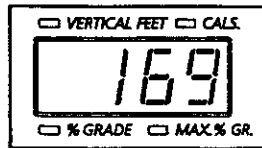

The Distance/Time display will show the total number of hours that the TREKKER has been used.

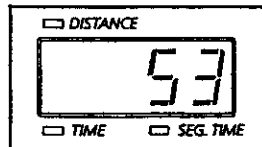

IMPORTANT: Make sure that there is not a letter "d" in the Heart Rate display. If a "d" appears in the display, the console is in the "demo" mode. This mode is intended to be used only when a TREKKER is displayed in a store. When the console is in the demo mode, the power cord can be plugged in, the key can be removed from the console, and the displays and indicators on the console will automatically light in a pre-set sequence, although the buttons on the console will not operate. If a "d" appears in the Heart Rate display when the information mode is selected, press the Speed - button so the display is blank.

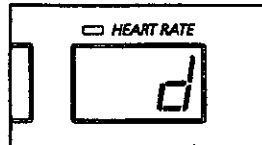

To exit the information mode, remove the key from the console.

THE OPTIONAL iFIT.COM MODULE

By adding an optional iFIT.com module to the TREKKER, you can use virtually endless features from our internet site.

Imagine on-line competitions, personal training sessions via the internet, and the ability to use your computer to track your programs. **For information about purchasing the optional iFIT.com module, call toll-free 1-800-735-0768.**

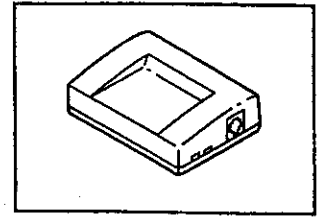

THE OPTIONAL HEART RATE MONITOR

An optional heart rate monitor adds even more features to the console. The heart rate monitor provides hands-free operation and continuously monitors your heart rate during your workouts. **To purchase the optional heart rate monitor, call toll-free 1-888-825-2588.**

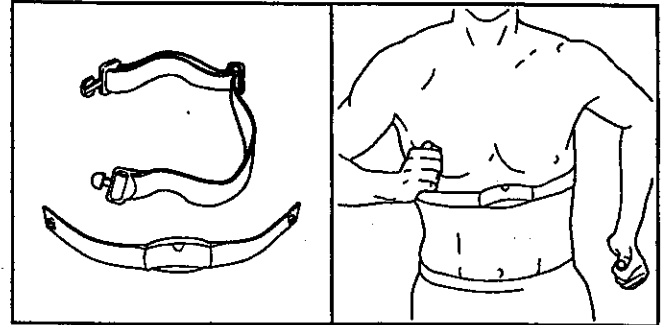

How to Move the TREKKER

Before moving the TREKKER, change the grade of the TREKKER to the lowest level and unplug the power cord.

1. Hold the handrails as shown and place one foot against the walking belt.
2. Tilt the TREKKER back until it rolls freely on the wheels. The help of a second person may be helpful when tipping the TREKKER. Carefully move the TREKKER to the desired location. **Never move the TREKKER without tipping it back. To reduce the risk of injury, use extreme caution while moving the TREKKER. Do not attempt to move the TREKKER over an uneven surface.**
3. Place one foot on the walking belt, and carefully lower the TREKKER until it is resting on the floor.

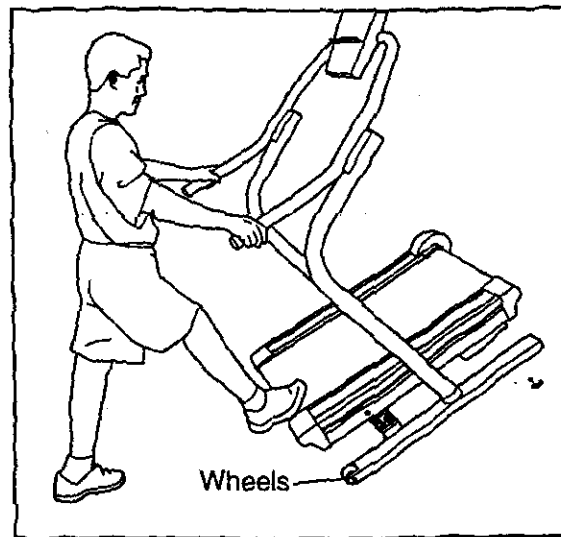

Trouble-shooting

Most problems can be solved by following the steps below. Find the symptom that applies, and follow the steps listed. If further assistance is needed, call our Customer Service Department toll-free at 1-888-825-2588, Monday through Friday, 6 a.m. until 6 p.m. Mountain Time (excluding holidays).

PROBLEM: The power does not turn on

SOLUTION: a. Make sure that the power cord is plugged into a surge suppressor, and that the surge suppressor is plugged into a properly grounded outlet (see page 8). Use only a single-outlet surge suppressor that is UL 1449 listed as a transient voltage surge suppressor (TVSS). The surge suppressor must have a UL suppressed voltage rating of 400 volts or less and a minimum surge dissipation of 450 joules. The surge suppressor must be electrically rated for 120 volts AC and 15 amps. **Important:** The TREKKER is not compatible with GFCI-equipped outlets.

b. After the power cord has been plugged in, make sure that the key is fully inserted into the console.

c. Check the circuit breaker located on the TREKKER near the power cord. If the switch protrudes as shown, the circuit breaker has tripped. To reset the circuit breaker, wait for five minutes and then press the switch back in.

d. Check the on/off switch located on the TREKKER near the power cord. The switch must be in the on position.

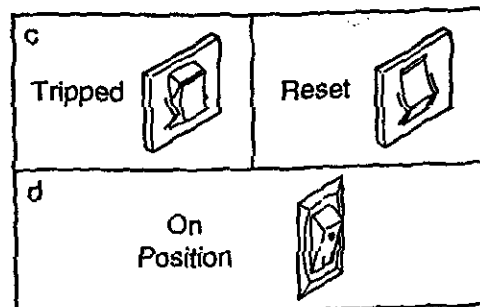

PROBLEM: The power turns off during use

- SOLUTION:**
- a. Check the circuit breaker located on the TREKKER near the power cord (see c. on page 20). If the circuit breaker has tripped, wait for five minutes and then press the switch back in.
 - b. Make sure that the power cord is plugged in.
 - c. Remove the key from the console. Re-insert the key fully into the console.
 - d. Make sure that the on/off switch is in the "on" position.
 - e. If the TREKKER still will not run, please call our Customer Service Department, toll-free.

PROBLEM: The key is inserted and the displays on the console are lit, but the walking belt will not start

- SOLUTION:** a. Unplug the power cord, wait for five minutes, and then plug the power cord back in.

PROBLEM: The displays of the console do not function properly

- SOLUTION:** a. Remove the key from the console and **UNPLUG THE POWER CORD**. Remove the two indicated Screws (118) from the Belly Pan (16). Loosen the other indicated Screw three turns. Carefully lift the Front Roller Cover (14).

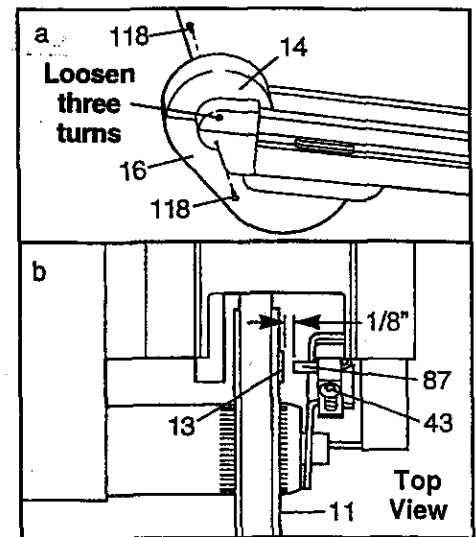

- b. Locate the Reed Switch (87) and the Magnet (13) on the side of the Pulley (11). Turn the Pulley until the Magnet is aligned with the Reed Switch. **Make sure that the gap between the Magnet and the Reed Switch is about 1/8"**. If necessary, loosen the Screw (43) and move the Reed Switch slightly. Retighten the Screw. Re-attach the front roller cover, and run the TREKKER for a few minutes to check for a correct speed reading.

PROBLEM: The grade of the TREKKER does not change correctly or does not change when iFIT.com CD's and videocassettes are played

- SOLUTION:**
- a. With the key in the console, press one of the Grade buttons. **While the grade is changing, remove the key.** After a few seconds, re-insert the key. The TREKKER will automatically rise to the highest grade and then return to the lowest grade. This will recalibrate the TREKKER.
 - b. If an "E6" appears in the Distance/Time display, remove the key and unplug the power cord. Wait for sixty seconds, plug in the power cord, and re-insert the key.

PROBLEM: The walking belt slows when walked on

SOLUTION: a. Use only a UL-listed surge protector, rated at 15 amps, with a 14-gauge cord of five feet or less in length.

b. If the walking belt is overtightened, TREKKER performance may decrease and the walking belt may become damaged. Remove the key and **UNPLUG THE POWER CORD**. Using the allen wrench, turn both rear roller adjustment bolts counterclockwise, 1/4 of a turn. When the walking belt is correctly tightened, you should be able to lift each side of the walking belt 2 to 3 inches off the walking platform. Be careful to keep the walking belt centered. Plug in the power cord, insert the key and carefully walk on the TREKKER for a few minutes. Repeat until the walking belt is properly tightened.

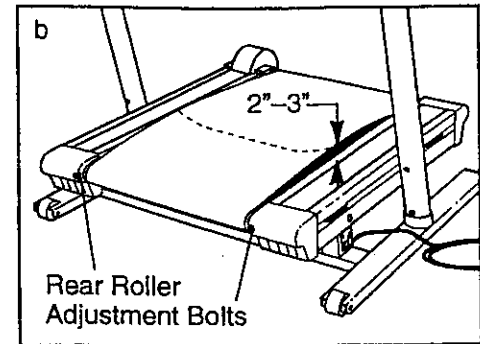

c. If the walking belt still slows, please call our Customer Service Department, toll-free.

PROBLEM: The walking belt is off-center

SOLUTION: a. If the walking belt has shifted to the left, first remove the key and **UNPLUG THE POWER CORD**. Using the allen wrench, turn the left rear roller adjustment bolt clockwise, and the right bolt counterclockwise, 1/4 of a turn each. Be careful not to overtighten the walking belt. Plug in the power cord, insert the key and run the TREKKER for a few minutes. Repeat until the walking belt is centered.

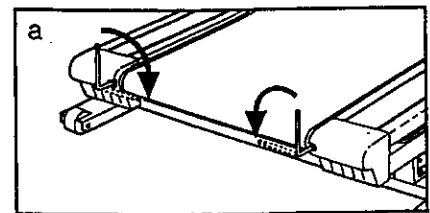

b. If the walking belt has shifted to the right, first remove the key and **UNPLUG THE POWER CORD**. Using the allen wrench, turn the left rear roller adjustment bolt counterclockwise, and the right bolt clockwise, 1/4 of a turn each. Be careful not to overtighten the walking belt. Plug in the power cord, insert the key and run the TREKKER for a few minutes. Repeat until the walking belt is centered.

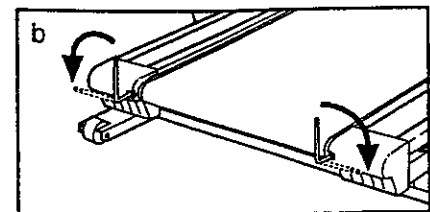

PROBLEM: The walking belt slips when walked on

SOLUTION: a. If the walking belt slips when walked on, first remove the key and **UNPLUG THE POWER CORD**. Using the allen wrench, turn both rear roller adjustment bolts clockwise, 1/4 of a turn. When the walking belt is correctly tightened, you should be able to lift each side of the walking belt 3 to 4 inches off the walking platform. Be careful to keep the walking belt centered. Plug in the power cord, insert the key and carefully walk on the TREKKER for a few minutes. Repeat until the walking belt is properly tightened.

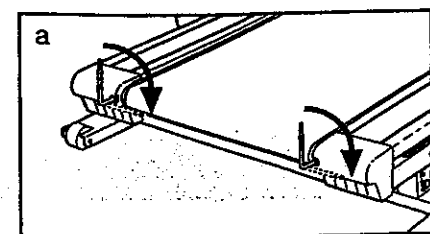

Conditioning Guidelines

⚠ WARNING: Before beginning this or any exercise program, consult your physician. This is especially important for individuals over the age of 35 or individuals with pre-existing health problems.

The following guidelines will help you to plan your exercise program. Remember—these are general guidelines only. For more detailed exercise information, obtain a reputable book or consult your physician.

EXERCISE INTENSITY

Whether your goal is to burn fat or to strengthen your cardiovascular system, the key to achieving the desired results is to exercise with the proper intensity. The proper intensity level can be found by using your heart rate as a guide. The chart below shows recommended heart rates for fat burning and aerobic exercise.

To find the proper heart rate for you, first find your age near the bottom of the chart (ages are rounded off to the nearest ten years). Next, find the three numbers above your age. The three numbers define your "training zone." The lower two numbers are recommended heart rates for fat burning; the higher number is the recommended heart rate for aerobic exercise.

AEROBIC	165	155	145	140	130	125	115
MAX FAT BURN	145	138	130	125	118	110	103
FAT BURN	125	120	115	110	105	95	90
Age	20	30	40	50	60	70	80

Fat Burning

To burn fat effectively, you must exercise at a relatively low intensity level for a sustained period of time. During the first few minutes of exercise, your body uses easily accessible *carbohydrate calories* for energy. Only after the first few minutes does your body begin to use stored *fat calories* for energy. If your goal is to burn fat, adjust the grade and speed of the TREKKER until your heart rate is near the lowest number in your training zone.

For maximum fat burning, adjust the grade and speed of the TREKKER until your heart rate is near the middle number in your training zone.

Aerobic Exercise

If your goal is to strengthen your cardiovascular system, your exercise must be "aerobic." Aerobic exercise is activity that requires large amounts of oxygen for prolonged periods of time. This increases the demand on the heart to pump blood to the muscles, and on the lungs to oxygenate the blood. For aerobic exercise, adjust the grade and speed of the TREKKER until your heart rate is near the highest number in your training zone.

HOW TO MEASURE YOUR HEART RATE

To measure your heart rate, stop exercising and place two fingers on your wrist as shown. Take a six-second heartbeat count, and multiply the result by ten to find your heart rate. (A six-second count is used because your heart rate drops quickly when you stop exercising.)

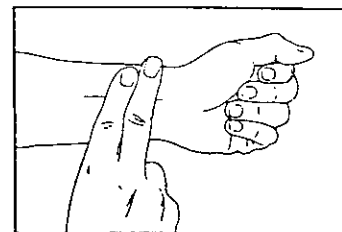

PROGRAM GUIDELINES

Each program should include the following three parts:

A Warm-up—Start each program with 5 to 10 minutes of stretching and light exercise. A proper warm-up increases your body temperature, heart rate and circulation in preparation for exercise.

Training Zone Exercise—After warming up, increase the intensity of your exercise until your heart rate is in your training zone for 20 to 60 minutes. (During the first few weeks of your exercise program, do not keep your heart rate in your training zone for longer than 20 minutes.) Breathe regularly and deeply as you exercise.

A Cool-down—Finish each program with 5 to 10 minutes of stretching to cool down. This will increase the flexibility of your muscles and will help prevent post-exercise problems.

Exercise Frequency

To maintain or improve your condition, complete three programs each week, with at least one day of rest between programs. After a few months, you may complete up to five programs each week if desired. The key to success is to make exercise a regular and enjoyable part of your everyday life.

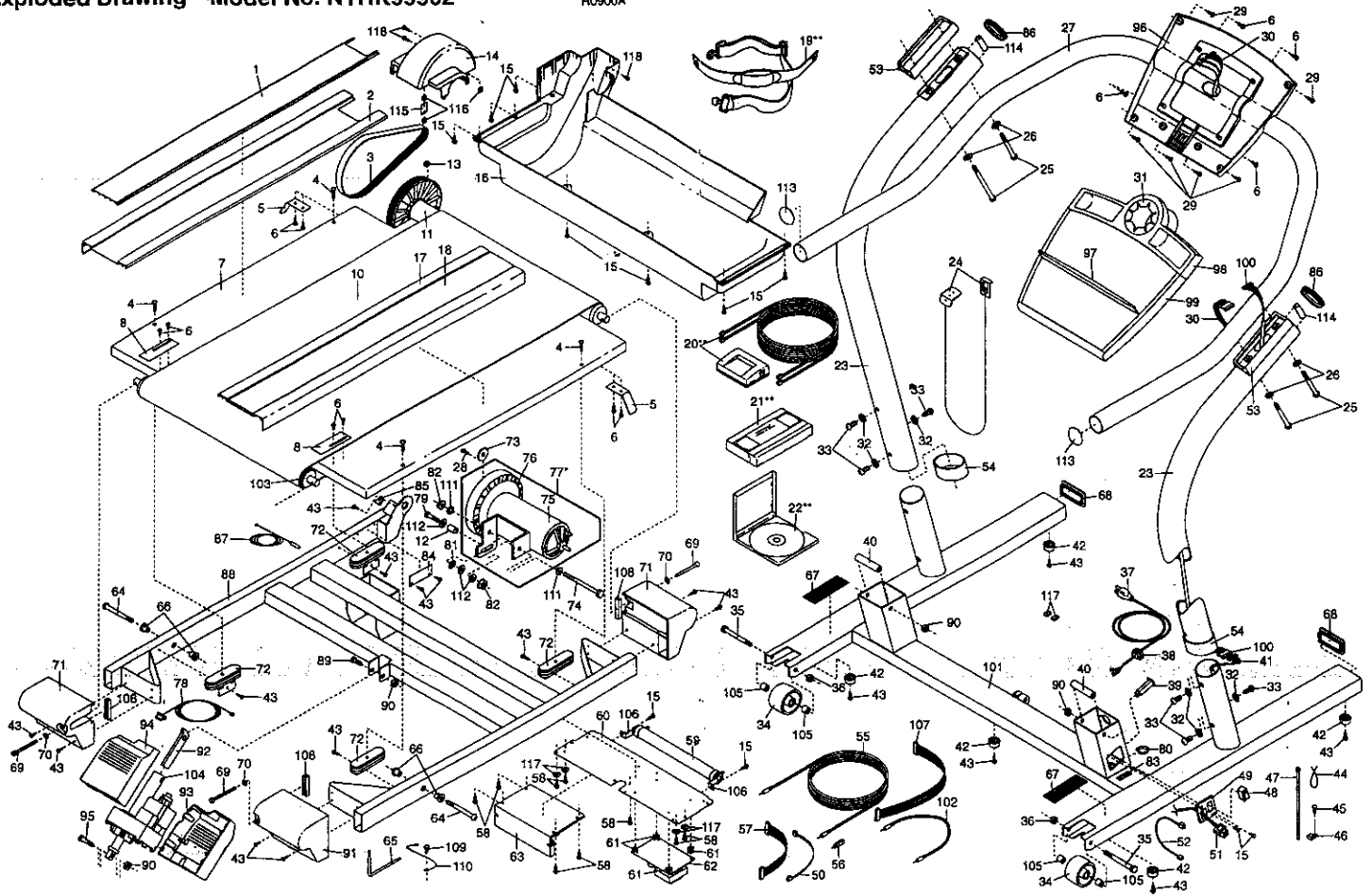

Part List—Model No. NTHK99902

R0900A

Key No.	Qty.	Description	Key No.	Qty.	Description	Key No.	Qty.	Description
1	1	Left Foot Rail Insert	51	1	iFIT.com Connector	98	1	Cup Holder/Tray
2	1	Left Foot Rail	52	1	iFIT.com Wire	99	1	Console
3	1	Motor Belt	53	2	Handrail Cover	100	1	Upright Wire Harness
4	4	Platform Screw	54	4	Upright Collar	101	1	Base
5	2	Belt Guide	55	1	10' iFIT.com Audio Cable	102	1	6" Audio Wire
6	12	Small Screw	56	1	iFIT.com Jack	103	1	Rear Roller
7	1	Walking Platform	57	1	iFIT.com Wire	104	1	Incline Motor
8	2	Roller Guard	58	4	Electronics Screw	105	4	Wheel Spacer
9	5	Resistor Screw	59	1	Resistor	106	2	Resistor Bracket
10	1	Walking Belt	60	1	Electronics Bracket	107	1	32" Wire Harness
11	1	Drive Roller/Pulley	61	4	Plastic Stand-off	108	3	Endcap Spacer
12	1	Motor Pivot Sleeve	62	1	Power Board	109	1	Ground Wire Screw
13	1	Magnet	63	1	Controller	110	1	Ground Wire
14	1	Front Roller Cover	64	2	Frame Pivot Bolt	111	2	Motor Bushing
15	9	Belly Pan Screw	65	1	Allen Wrench	112	4	Motor Spacer
16	1	Belly Pan	66	4	Frame Bushing	113	2	Handrail Endcap
17	1	Right Foot Rail Insert	67	2	Warning Decal	114	2	Metal Spacer
18	1	Right Foot Rail	68	2	Base Endcap	115	1	Roller Cover Plate
19*	1	Chest Pulse	69	3	Roller Adj. Bolt	116	3	Cover Clip
20**	1	iFIT.com Module	70	3	Roller Adj. Washer	117	4	Bracket Washer
21**	1	iFIT.com Videocassette	71	2	Frame Endcap	118	3	Roller Cover Screw
22**	1	iFIT.com CD	72	4	Isolator	#	1	14" Blue Wire, M/F
23	2	Upright	73	1	Flywheel Washer	#	1	8" Blue Wire, F/Flag
24	1	Key/Clip	74	1	Motor Pivot Bolt	#	1	4" Blue Wire
25	4	Handrail Bolt	75	1	Motor	#	1	8" Green Wire, F/Ring
26	4	Handrail Star Washer	76	1	Pulley/Flywheel/Fan	#	1	6" Green Wire, 2 Ring
27	1	Handrail	77*	1	Motor/Pulley/Flywheel/Fan	#	1	4" Green Wire, F/Ring
28	1	Flywheel Screw	78	1	30" Extension Wire	#	1	8" Red Wire, 2F
29	6	Screw	79	1	Motor Tension Bolt	#	1	10" Red Wire, 2F
30	1	Handrail Wire Harness	80	1	Grommet	#	1	10" White Wire, 2F
31	1	Cup Holder Flange	81	1	Motor Star Washer	#	1	User's Manual
32	6	Upright Washer	82	2	Motor Tension Nut			
33	6	Upright Bolt	83	1	Static Decal			
34	2	Wheel	84	1	Plastic Plate			
35	2	Wheel Bolt	85	1	Reed Switch Clip			
36	2	Wheel Nut	86	2	Upright Endcap			
37	1	Power Cord	87	1	Reed Switch/Wire			
38	1	Power Cord Grommet	88	1	Frame			
39	1	Circuit Breaker	89	1	Incline Motor Bolt (Short)			
40	2	Frame Pivot Spacer	90	4	Incline Motor Nut/Frame Pivot Nut			
41	1	Base Wire Harness						
42	5	Base Pad	91	1	Rear Endcap (Right)			
43	20	Screw	92	1	Incline Motor Insert			
44	1	Releasable Tie	93	1	Incline Motor Cover (Bottom)			
45	1	Tie Screw						
46	1	Tie Holder	94	1	Incline Motor Cover (Top)			
47	1	8" Cable Tie						
48	1	On/Off Switch	95	1	Incline Motor Bolt (Long)			
49	1	Outlet Cover	96	1	Console Base (Bottom)			
50	1	14" Controller Wire	97	1	Book Holder			

* Includes all parts shown in the box

**These parts are optional. For information about the iFIT.com module, iFIT.com CD's, or iFIT.com video-cassettes, call toll-free 1-800-735-0768.

These parts are not illustrated

Ordering Replacement Parts

To order replacement parts, call our Customer Service Department toll-free at 1-888-825-2588, Monday through Friday, 6 a.m. until 6 p.m. Mountain Time (excluding holidays). When ordering parts, please be prepared to give the following information:

- The MODEL NUMBER OF THE PRODUCT (NTHK99902)
- The NAME OF THE PRODUCT (NordicTrack® ADVENTURER TREKKER™)
- The SERIAL NUMBER OF THE PRODUCT (see the front cover of this manual)
- The KEY NUMBER AND DESCRIPTION OF THE PART(S) (see the accompanying PART LIST and EXPLODED DRAWING).

If possible, place the TREKKER near your telephone for easy reference when calling.

Limited Warranty

ICON Health & Fitness, Inc. (ICON), warrants this product to be free from defects in workmanship and material, under normal use and service conditions, for a period of ninety (90) days from the date of purchase. This warranty extends only to the original purchaser. ICON's obligation under this warranty is limited to replacing or repairing, at ICON's option, the product at one of its authorized service centers. All products for which warranty claim is made must be received by ICON at one of its authorized service centers with all freight and other transportation charges prepaid, accompanied by sufficient proof of purchase. All returns must be pre-authorized by ICON. This warranty does not extend to any product or damage to a product caused by or attributable to freight damage, abuse, misuse, improper or abnormal usage or repairs not provided by an ICON authorized service center, to products used for commercial or rental purposes, or to products used as store display models. No other warranty beyond that specifically set forth above is authorized by ICON.

ICON is not responsible or liable for indirect, special or consequential damages arising out of or in connection with the use or performance of the product or damages with respect to any economic loss, loss of property, loss of revenues or profits, loss of enjoyment or use, costs of removal, installation or other consequential damages of whatsoever nature. Some states do not allow the exclusion or limitation of incidental or consequential damages. Accordingly, the above limitation may not apply to you.

The warranty extended hereunder is in lieu of any and all other warranties and any implied warranties of merchantability or fitness for a particular purpose is limited in its scope and duration to the terms set forth herein. Some states do not allow limitations on how long an implied warranty lasts. Accordingly, the above limitation may not apply to you.

This warranty gives you specific legal rights. You may also have other rights which vary from state to state.

ICON HEALTH & FITNESS, INC., 1500 S. 1000 W., LOGAN, UT 84321-9813