

SEARS

OWNERS
MANUAL

MODEL NO.
315.117151

CAUTION:
Read Rules for
Safe Operation
and Instructions
Carefully

SAVE THIS
MANUAL FOR
FUTURE REFERENCE

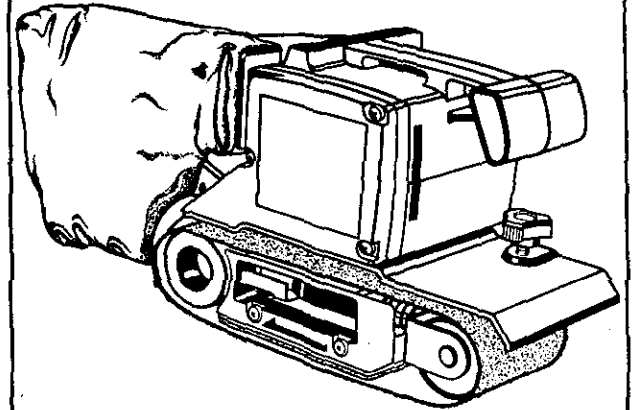

CRAFTSMAN
**3 INCH DUSTLESS
BELT SANDER**
DOUBLE INSULATED

Warranty
Introduction
Operation
Maintenance
Repair Parts



612547-530
10-00

Sold only by
SEARS, ROEBUCK AND CO., Hoffman Estates, IL 60179

Printed in U.S.A.

FULL ONE YEAR WARRANTY ON CRAFTSMAN BELT SANDER

If this Craftsman Belt Sander fails to give complete satisfaction within one year from the date of purchase, **RETURN IT TO THE NEAREST SEARS STORE IN THE UNITED STATES**, and Sears will repair it, free of charge.

If this Craftsman Belt Sander is used for commercial or rental purposes, this warranty applies for only 90 days from the date of purchase.

This warranty gives you specific legal rights, and you may also have other rights which vary from state to state.

Sears, Roebuck and Co., DEPT. 817 WA, Hoffman Estates, IL 60179

INTRODUCTION

DOUBLE INSULATION is a concept in safety, in electric power tools, which eliminates the need for the usual three wire grounded power cord and grounded supply system. Wherever there is electric current in the tool there are two complete sets of insulation to protect the user. All exposed metal parts are isolated from internal metal motor components with protecting insulation.

GENERAL

Your Craftsman Belt Sander is suitable for coarse, medium and fine sanding of wood, metals, plastics and other materials. It is ideal when used for smoothing rough boards, chamfering, rounding edges and many other general sanding applications. It is also an excellent tool for removing paint, varnishes, and stains. Its balanced design makes it easy to use.

IMPORTANT - Servicing of a tool with double insulation requires extreme care and knowledge of the system and should be performed only by a qualified service technician. For service we suggest you return the tool to your nearest Sears Store for repair. Always use original factory replacement parts when servicing.

RULES FOR SAFE OPERATION

WARNING: THE DOUBLE INSULATED SYSTEM IS INTENDED TO PROTECT THE USER FROM SHOCK RESULTING FROM A BREAK IN THE TOOL'S INTERNAL WIRING. OBSERVE ALL NORMAL SAFETY PRECAUTIONS RELATED TO AVOIDING ELECTRICAL SHOCK.

WARNING: DO NOT ATTEMPT TO OPERATE THIS TOOL UNTIL YOU HAVE READ THOROUGHLY AND UNDERSTAND COMPLETELY ALL INSTRUCTIONS, SAFETY RULES, ETC. CONTAINED IN THIS MANUAL. FAILURE TO COMPLY CAN RESULT IN ACCIDENTS INVOLVING FIRE, ELECTRIC SHOCK, OR SERIOUS PERSONAL INJURY. SAVE OWNERS MANUAL AND REVIEW FREQUENTLY FOR CONTINUING SAFE OPERATION, AND INSTRUCTING OTHERS WHO MAY USE THIS TOOL.

READ ALL INSTRUCTIONS

1. **KNOW YOUR POWER TOOL** - Read owner's manual carefully. Learn its applications and limitations as well as the specific potential hazards related to this tool.
2. **GUARD AGAINST ELECTRICAL SHOCK BY PREVENTING BODY CONTACT WITH GROUNDED SURFACES.** For example: Pipes, radiators, ranges, refrigerator enclosures.
3. **KEEP GUARDS IN PLACE** and in working order.
4. **KEEP WORK AREA CLEAN.** Cluttered areas and benches invite accidents.
5. **AVOID DANGEROUS ENVIRONMENT.** Don't use power tool in damp or wet locations or expose to rain. Keep work area well lit.
6. **KEEP CHILDREN AND VISITORS AWAY.** All visitors should wear safety glasses and be kept a safe distance from work area. Do not let visitors contact tool or extension cord.
7. **STORE IDLE TOOLS.** When not in use tools should be stored in a dry, high or locked-up place - out of the reach of children.
8. **DON'T FORCE TOOL.** It will do the job better and safer at the rate for which it was designed.
9. **USE RIGHT TOOL.** Don't force small tool or attachment to do the job of a heavy duty tool. Don't use tool for purpose not intended - for example - Don't use a circular saw for cutting tree limbs or logs.

RULES FOR SAFE OPERATION (Continued)

10. **WEAR PROPER APPAREL.** No loose clothing or jewelry to get caught in moving parts. Rubber gloves and non-skid footwear are recommended when working outdoors. Also, wear protective hair covering to contain long hair and keep it from being drawn into air vents.
11. **ALWAYS WEAR SAFETY GLASSES.** Everyday eyeglasses have only impact-resistant lenses; they are **NOT** safety glasses.
12. **PROTECT YOUR LUNGS.** Wear a face or dust mask if operation is dusty.
13. **PROTECT YOUR HEARING.** Wear hearing protection during extended periods of operation.
14. **DON'T ABUSE CORD.** Never carry tool by cord or yank it to disconnect from receptacle. Keep cord from heat, oil and sharp edges.
15. **SECURE WORK.** Use clamps or a vise to hold work. Both hands are needed to operate the tool.
16. **DON'T OVERREACH.** Keep proper footing and balance at all times. Do not use on a ladder or unstable support.
17. **MAINTAIN TOOLS WITH CARE.** Keep tools sharp at all times, and clean for best and safest performance. Follow instructions for lubricating and changing accessories.
18. **DISCONNECT TOOLS.** When not in use, before servicing, or when changing sanding belts, attachments, blades, bits, cutters, etc., all tools should be disconnected from power supply.
19. **REMOVE ADJUSTING KEYS AND WRENCHES.** Form habit of checking to see that keys and adjusting wrenches are removed from tool before turning it on.
20. **AVOID ACCIDENTAL STARTING.** Don't carry plugged-in tools with finger on switch. Be sure switch is off when plugging in.
21. **MAKE SURE YOUR EXTENSION CORD IS IN GOOD CONDITION.** When using an extension cord, be sure to use one heavy enough to carry the current your product will draw. An undersized cord will cause a drop in line voltage resulting in loss of power and overheating. A wire gage size (A.W.G.) of at least 14 is recommended for an extension cord 100 feet or less in length. A cord exceeding 100 feet is not recommended. If in doubt, use the next heavier gage. The smaller the gage number, the heavier the cord.
22. **OUTDOOR USE EXTENSION CORDS.** When tool is used outdoors, use only extension cords suitable for use outdoors. Outdoor approved cords are marked with the suffix W-A, for example - SJTW-A or SJOW-A.
23. **NEVER USE THIS OR ANY POWER SANDER FOR WET SANDING.** Failure to comply can result in electrical shock causing serious injury or worse.
24. **KEEP HANDS AWAY FROM SANDING AREA.**
25. **NEVER USE IN AN EXPLOSIVE ATMOSPHERE.** Normal sparking of the motor could ignite fumes.
26. **INSPECT TOOL CORDS PERIODICALLY** and if damaged, have repaired at your nearest Sears Repair Center. Stay constantly aware of cord location.
27. **INSPECT EXTENSION CORDS PERIODICALLY** and replace if damaged.
28. **KEEP HANDLES DRY, CLEAN, AND FREE FROM OIL AND GREASE.** Always use a clean cloth when cleaning. Never use brake fluids, gasoline, petroleum-based products or any strong solvents to clean your tool.
29. **STAY ALERT.** Watch what you are doing and use common sense. Do not operate tool when you are tired. Do not rush.
30. **CHECK DAMAGED PARTS.** Before further use of the tool, a guard or other part that is damaged should be carefully checked to determine that it will operate properly and perform its intended function. Check for alignment of moving parts, binding of moving parts, breakage of parts, mounting, and any other conditions that may affect its operation. A guard or other part that is damaged should be properly repaired or replaced by an authorized service center unless indicated elsewhere in this instruction manual.
31. **DO NOT USE TOOL IF SWITCH DOES NOT TURN IT ON AND OFF.** Have defective switches replaced by an authorized service center.
32. Inspect for and remove all nails from lumber before sanding.
33. **DRUGS, ALCOHOL, MEDICATION.** Do not operate tool while under the influence of drugs, alcohol, or any medication.
34. **DO NOT USE THIS SANDER FOR OVERHEAD SANDING.** Overhead sanding could result in dropping sander or loss of control. These situations could result in an accident resulting in possible serious injury.
35. **WHEN SERVICING USE ONLY IDENTICAL CRAFTSMAN REPLACEMENT PARTS.**
36. **POLARIZED PLUGS.** To reduce the risk of electric shock, this tool has a polarized plug (one blade is wider than the other). This plug will fit in a polarized outlet only one way. If the plug does not fit fully in the outlet, reverse the plug. If it still does not fit, contact a qualified electrician to install the proper outlet. Do not change the plug in any way.
37. **SAVE THESE INSTRUCTIONS.** Refer to them frequently and use to instruct others who may use this tool. If you loan someone this tool, loan them these instructions also.

▲WARNING: SOME DUST CREATED BY POWER SANDING, SAWING, GRINDING, DRILLING, AND OTHER CONSTRUCTION ACTIVITIES CONTAINS CHEMICALS KNOWN TO CAUSE CANCER, BIRTH DEFECTS OR OTHER REPRODUCTIVE HARM. SOME EXAMPLES OF THESE CHEMICALS ARE:

- LEAD FROM LEAD-BASED PAINTS,
- CRYSTALLINE SILICA FROM BRICKS AND CEMENT AND OTHER MASONRY PRODUCTS, AND
- ARSENIC AND CHROMIUM FROM CHEMICALLY-TREATED LUMBER.

YOUR RISK FROM THESE EXPOSURES VARIES, DEPENDING ON HOW OFTEN YOU DO THIS TYPE OF WORK. TO REDUCE YOUR EXPOSURE TO THESE CHEMICALS: WORK IN A WELL VENTILATED AREA, AND WORK WITH APPROVED SAFETY EQUIPMENT, SUCH AS THOSE DUST MASKS THAT ARE SPECIALLY DESIGNED TO FILTER OUT MICROSCOPIC PARTICLES.

THE FOLLOWING RECOMMENDED ACCESSORIES ARE CURRENT AND WERE AVAILABLE AT THE TIME THIS MANUAL WAS PRINTED.

CRAFTSMAN,

3 in. x 21 in. Aluminum Oxide Plyweld Belts

3 in. x 21 in. "Sears Best" Zirconium Plyweld Belts

▲WARNING: The use of attachments or accessories not listed above might be hazardous.

WARNING:



The operation of any sander can result in foreign objects being thrown into your eyes, which can result in severe eye damage. Before beginning power tool operation, always wear safety goggles or safety glasses with side shields and a full face shield when needed. We recommend Wide Vision Safety Mask for use over eyeglasses or standard safety glasses with side shields, available at Sears Retail Stores.

OPERATION

⚠ WARNING: YOUR SANDER SHOULD NEVER BE CONNECTED TO POWER SUPPLY WHEN YOU ARE ASSEMBLING PARTS, CHANGING BELTS, OR MAKING ADJUSTMENTS.

⚠ WARNING: IF ANY PARTS ARE MISSING DO NOT OPERATE YOUR TOOL UNTIL THE MISSING PARTS ARE REPLACED. FAILURE TO DO SO COULD RESULT IN POSSIBLE SERIOUS PERSONAL INJURY.

Make sure power supply is 110-120 volts, 60 HZ, AC only.

Before attempting to use your Sander, familiarize yourself with all operating features (See Figure 1) and safety requirements.

⚠ WARNING: DO NOT ALLOW FAMILIARITY WITH YOUR SANDER TO MAKE YOU CARELESS. REMEMBER THAT A CARELESS FRACTION OF A SECOND IS SUFFICIENT TO INFLICT SEVERE INJURY.

SWITCH

The switch of your sander is equipped with a "lock-on" feature which is convenient when sanding for extended periods of time. To lock-on, simply depress the trigger of the switch, push in the lock button located on the side of the handle, then while holding the lock button pushed in, release the trigger. See Figure 2. To release the lock, depress the trigger and release it. If you have the "Lock-On" feature engaged during use and your Sander becomes disconnected from power supply, disengage the "Lock-On" feature immediately.

⚠ WARNING: BEFORE CONNECTING YOUR SANDER TO POWER SUPPLY SOURCE, ALWAYS CHECK TO BE SURE IT IS NOT IN "LOCK-ON" POSITION. FAILURE TO DO SO COULD RESULT IN ACCIDENTAL STARTING OF YOUR SANDER RESULTING IN POSSIBLE SERIOUS INJURY. ALSO, DO NOT LOCK THE TRIGGER ON JOBS WHERE YOUR SANDER MAY NEED TO BE STOPPED SUDDENLY.

PREPARING FOR OPERATION

For ease of operation and maintaining proper control, your Sander has a front handle and a rear handle. These handles allow two-hand operation which aid in maintaining control, keeping sanding area level with workpiece, and keeping hands clear of sanding belt. When operating your Sander always hold the front handle with your left hand and the rear handle with your right hand as shown in Fig. 2.

⚠ WARNING: KEEP HANDS AND FINGERS CLEAR OF MOVING SANDING BELT, FRONT IDLER PULLEY AND DRIVE ROLLER ASSEMBLY. FAILURE TO DO SO WILL RESULT IN THE SANDING OF YOUR HANDS OR FINGERS. See Fig. 3.

⚠ WARNING: DO NOT LET YOUR FINGERS REST OVER THE FRONT OR RIGHT EDGE OF THE SANDER. IF THE SANDING BELT WERE TO RUN OFF, OR IF IT WERE NOT PROPERLY ADJUSTED, YOUR FINGERS COULD COME IN CONTACT WITH THE MOVING SANDING BELT RESULTING IN POSSIBLE SERIOUS INJURY.

Always operate your Sander as shown in Fig. 2.

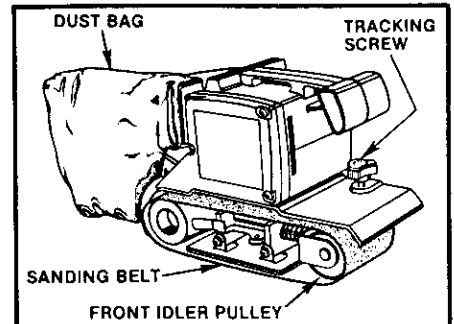

Fig. 1

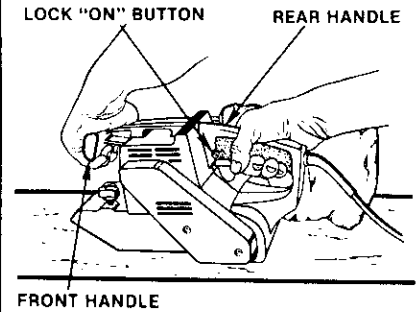

Fig. 2

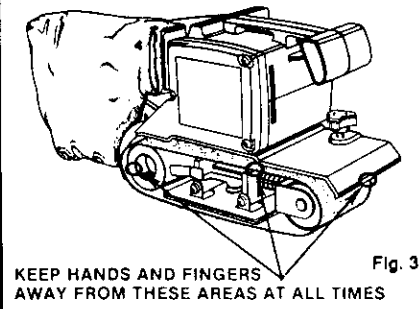

Fig. 3

OPERATION

Selecting the correct size and type sanding belt is an important step in achieving a high quality sanded finish. Standard 3 inch x 21 inch sanding belts made of aluminum oxide, silicone carbide, and other synthetic abrasives are best for power sanding. In general, coarse grit will remove the most material and fine grit will produce the smoothest finish in all sanding operations. The condition of the surface to be sanded will determine which grit belt will do the job. If the surface is rough, start with a coarse grit belt sanding until surface is uniform. Medium grit belt may then be used to remove scratches left by the coarser belt and fine grit belt used for finishing of the surface. Always continue sanding with each grit belt until the surface is uniform.

⚠ WARNING: ALWAYS WEAR SAFETY GOGGLES OR SAFETY GLASSES WITH SIDE SHIELDS WHEN OPERATING YOUR SANDER. IF THE SANDING OPERATION IS DUSTY, ALSO WEAR A FACE OR DUST MASK. FAILURE TO DO SO COULD RESULT IN DUST OR LOOSE PARTICLES BEING THROWN INTO YOUR EYES, RESULTING IN POSSIBLE SERIOUS INJURY.

INSTALLING DUST BAG

See Figure 4.

DISCONNECT SANDER FROM POWER SUPPLY WHILE ASSEMBLING PARTS OR MAKING ADJUSTMENTS.

TO INSTALL:

1. Fit opening in dust bag retainer over dust exhaust hole on blower cover.
2. Slide dust bag retainer in the direction of the arrow as shown in Figure 4.
3. Dust bag is secure when it fits snugly on blower cover.

⚠ WARNING: TO PREVENT THE POSSIBILITY OF SAWDUST BEING THROWN INTO YOUR FACE AND EYES, NEVER ATTEMPT TO USE YOUR SANDER WITHOUT DUST BAG PROPERLY INSTALLED. SAWDUST BEING THROWN INTO YOUR FACE AND EYES COULD RESULT IN POSSIBLE SERIOUS INJURY.

INSTALLING AND ADJUSTING SANDING BELT

DISCONNECT SANDER FROM POWER SUPPLY WHILE ASSEMBLING PARTS OR MAKING ADJUSTMENTS.

To release the sanding belt, lift tension release lever straight up as shown in figure 6. When sufficient force is exerted, the spring will be compressed allowing the pulley to lock in a rear position. This frees the sanding belt so it can be removed. Install new belt making sure arrow inside of belt is pointing in the direction of rotation, which is clockwise when looking into open side of sander. See Fig. 5. Roughly align the belt to its correct position, then release tension on pulley. Release tension by lowering tension release lever as shown in Figure 6. The pulley will snap back into operating position.

⚠ WARNING: KEEP HANDS AND FINGERS CLEAR OF FRONT IDLER PULLEY AND SPRING MECHANISM AT ALL TIMES. FAILURE TO DO SO COULD RESULT IN THEM GETTING PINCHED, RESULTING IN POSSIBLE SERIOUS INJURY.

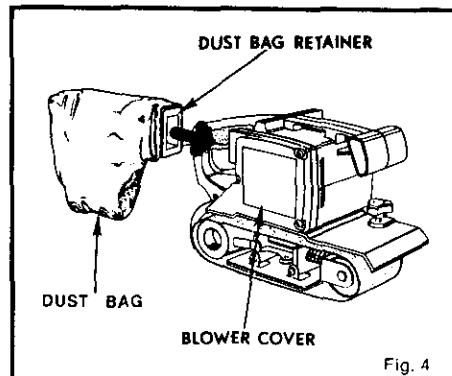

Fig. 4

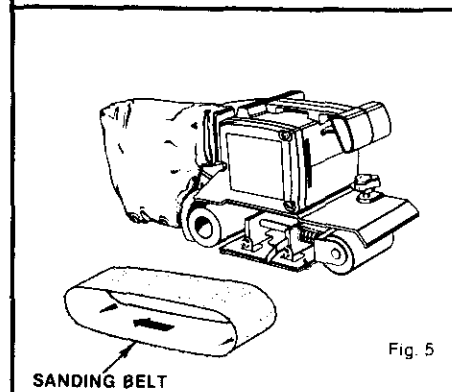

Fig. 5

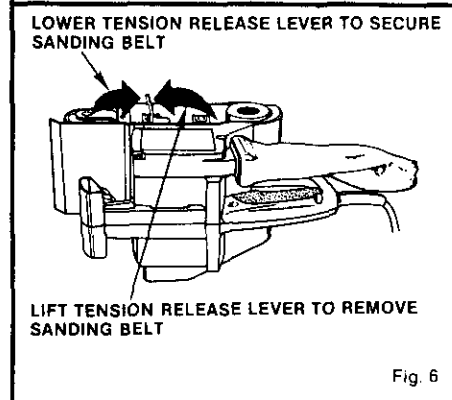

Fig. 6

OPERATION

ALWAYS WEAR SAFETY GOGGLES OR SAFETY GLASSES WITH SIDE SHIELDS WHEN OPERATING YOUR SANDER. To adjust sanding belt, connect Sander to power supply. Place Sander in upside down position as shown in Figure 7. **NOTE:** This position is for adjustments only. The Sander is not in an operating position. Pull switch trigger and release immediately. Observe tracking of sanding belt. If the sanding belt runs inward, turn the tracking screw clockwise. If the sanding belt runs outward, turn the tracking screw counterclockwise. This should be done until you are sure belt will not run off sander, or come in contact with internal parts. After installing a new sanding belt, it may become necessary to change the adjustment several times until the belt becomes pliable.

▲ WARNING: IF SANDING BELT BEGINS TO WEAR EXCESSIVELY ON THE INNER EDGE, RE-ADJUST TRACKING SCREW. IT IS ADJUSTED TOO FAR INWARD AND THE SANDING BELT IS RUBBING AGAINST INTERNAL PARTS.

When you are sure the belt will not rub against internal parts, start your Sander and fine adjust the tracking screw until the belt stabilizes. See Figure 8.

When correctly adjusted, the outer edge of the belt will be even with the outer edge of the base of your Sander. Belt life will be greatly increased if a few seconds are spent adjusting the belt tracking.

▲ WARNING: KEEP HANDS AND FINGERS AWAY FROM MOVING SANDING BELT. ANY PART OF YOUR BODY COMING IN CONTACT WITH MOVING BELT COULD RESULT IN SERIOUS INJURY. DO NOT WEAR LOOSE CLOTHING OR JEWELRY WHEN OPERATING YOUR SANDER. THEY COULD GET CAUGHT IN MOVING PARTS AND FOREIGN OBJECTS COULD GET THROWN AWAY FROM SANDER CAUSING INJURY.

TO OPERATE

Clamp or otherwise secure the work to prevent it from moving under your Sander.

▲ WARNING: UNSECURED WORK COULD BE THROWN BACK TOWARD OPERATOR CAUSING INJURY.

Before placing Sander on work surface, squeeze the trigger switch and let the motor reach its maximum speed, then lower your Sander to the work surface with a slight forward motion. Using the rear handle to control your Sander and the front handle only to guide it, move it slowly over the work. See Fig. 9. Allowing your Sander to remain in one place will result in an uneven surface.

▲ WARNING: KEEP A FIRM GRIP ON SANDER WITH BOTH HANDS AT ALL TIMES. FAILURE TO DO SO COULD RESULT IN LOSS OF CONTROL LEADING TO POSSIBLE SERIOUS INJURY.

Your sander was designed to provide the proper weight on the sanding belt. Extra pressure will result in uneven work, clogged belts, and possible motor burnout. **NOTE:** The front roller of your sander was not designed for contour sanding. Sanding on the front roller could cause irregularity in sanding belt tracking.

Use a coarser belt when heavy cutting is desired, not heavy pressure. The importance of this cannot be over-emphasized. The weight has been built into the tool to give the most efficient pressure at the proper location.

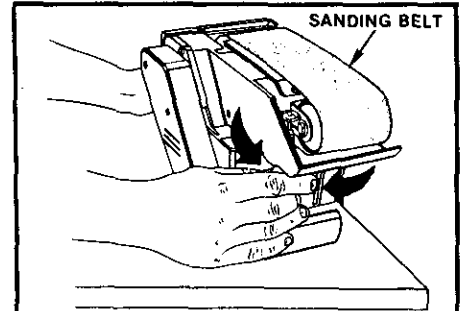

Fig. 7

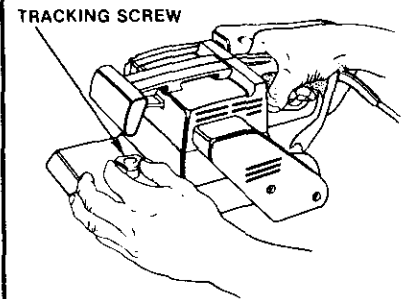

Fig. 8

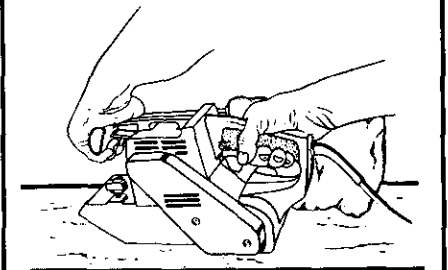

Fig. 9

MAINTENANCE

▲WARNING: WHEN SERVICING USE ONLY CRAFTSMAN IDENTICAL REPLACEMENT PARTS. USE OF ANY OTHER PARTS MAY CREATE A HAZARD OR CAUSE PRODUCT DAMAGE.

TIMING BELT REPLACEMENT

DISCONNECT SANDER FROM POWER SUPPLY BEFORE SERVICING

WHEN REPLACING TIMING BELT, USE REPLACEMENT BELT NUMBER 989368-000 ONLY. See Key Number 5 on Parts List, Page 11.

1. Remove sanding belt from sander. See installing and adjusting sanding belt, Page 5. **NOTE: REMOVING THE SANDING BELT WILL SIMPLIFY THE PROCESS OF INSTALLING YOUR NEW TIMING BELT.**
2. Remove the two belt cover screws. Then remove the belt cover. See Key Numbers 1 and 2 on exploded view and parts list, pages 10 and 11.
3. Force old belt from small pulley with a screwdriver and remove it from large pulley. If it is worn out, simply cut the old belt and remove it.
4. Install new belt over large pulley first. See Figure 10.
5. Holding the belt as shown in Figure 11, press the belt onto the small pulley. **NOTE: TO SIMPLIFY THE PROCESS, TURN THE LARGE PULLEY AS YOU PRESS THE BELT ONTO THE SMALL PULLEY.**
6. Reassemble belt cover and screws.

▲CAUTION: NEVER ATTEMPT TO OPERATE YOUR SANDER WITHOUT BELT COVER IN PLACE.

SWITCH REPLACEMENT

DISCONNECT THE SANDER FROM POWER SUPPLY WHILE REPLACING PARTS OR MAKING ADJUSTMENTS.

1. Remove the handle cover and screws. **NOTE THE LOCATIONS OF ALL WIRING IN THE HANDLE AND HOW EACH CONNECTION IS MADE TO THE SWITCH.** Connections and wiring position must be identical when installing the new switch. See Figure 12.
2. Lift the switch away from the handle, then release the leads to the switch by inserting a 1/32 in. diameter pin or nail into each switch lead receptacle. See Figure 13.
3. Make the lead connections to the new switch by pushing each lead as far as possible into the switch lead receptacles. Pull on leads to check lead connections with lead receptacles.
4. Arrange the wiring in the handle so that it will not be pinched or contact screws when the handle cover and screws are replaced, then position the switch in place. See Figure 12.
5. Place the cord and bend relief in their correct locations. See Figure 12.
6. Replace handle cover and screws.
7. Tighten all screws securely.

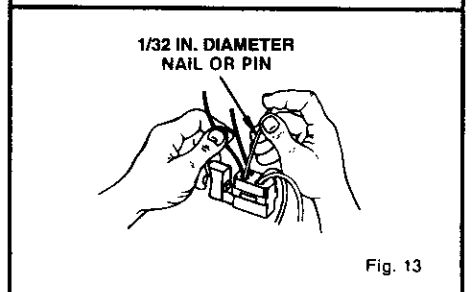
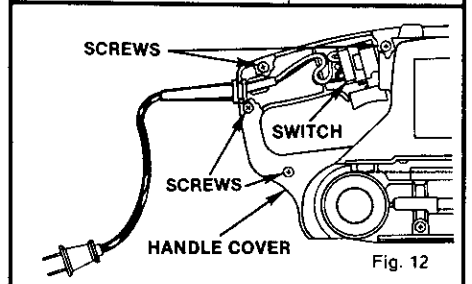
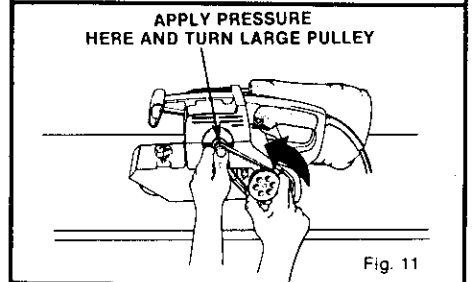
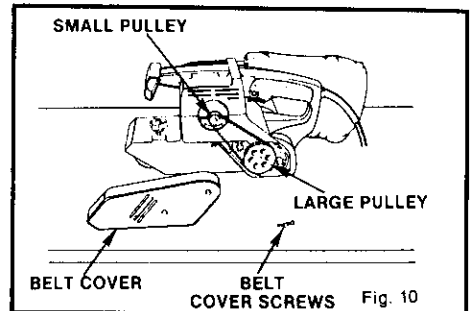

CORD REPLACEMENT

DISCONNECT THE SANDER FROM POWER SUPPLY WHILE REPLACING PARTS OR MAKING ADJUSTMENTS.

1. Remove handle cover and screws as described on Page 7. Note the locations of all wiring in the handle and how each connection is made to the cord. Connections and wiring position must be identical when installing the new cord. See Figure 14.
2. Remove the switch from the handle and disconnect the cord leads from the switch. See Figure 15.
3. Remove the bend relief from old cord and place it on the new one.
4. Push each lead of the new cord as far as possible into the proper switch lead receptacles. Pull on leads to check lead connections with lead receptacles.
5. Arrange the wiring in the handle so that it will not be pinched when handle cover and screws are replaced. Position the switch in place. See Figure 14.
6. Place the bend relief and cord in their correct locations, then replace handle cover and screws.
7. Tighten all screws securely.

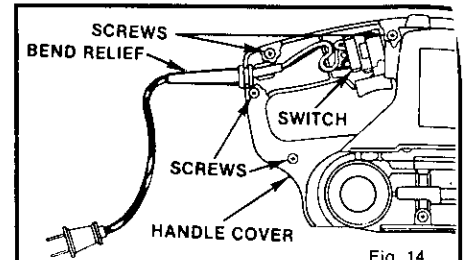

Fig. 14

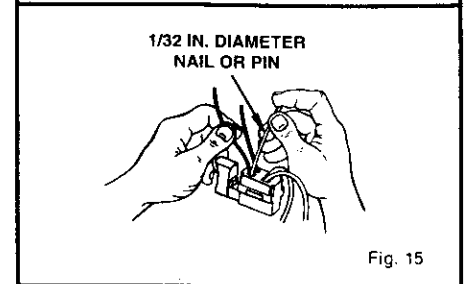

Fig. 15

GENERAL

Only the parts shown on parts list, page eleven, are intended to be repaired or replaced by the customer. All other parts represent an important part of the double insulation system and should be serviced only by a qualified service technician.

Avoid using solvents when cleaning plastic parts. Most plastics are susceptible to various types of commercial solvents and may be damaged by their use. Use clean cloths to remove dirt, carbon dust, etc.

⚠ WARNING: DO NOT AT ANY TIME LET BRAKE FLUIDS, GASOLINE, PETROLEUM-BASED PRODUCTS, PENETRATING OILS, ETC. COME IN CONTACT WITH PLASTIC PARTS. THEY CONTAIN CHEMICALS THAT CAN DAMAGE, WEAKEN, OR DESTROY PLASTIC.

When electric tools are used on fiberglass boats, sports cars, etc., it has been found that they are subject to accelerated wear and possible premature failure, as the fiberglass chips and grindings are highly abrasive to bearings, brushes, commutator, etc. Consequently it is not recommended that this tool be used for extended work on any fiberglass material. During any use on fiberglass it is extremely important that the tool is cleaned frequently by blowing with an air jet. **ALWAYS WEAR SAFETY GOGGLES, SAFETY GLASSES WITH SIDE SHIELDS, OR A DUST MASK DURING POWER TOOL OPERATION OR WHEN BLOWING DUST.**

LUBRICATION

All the bearings in this tool are lubricated with a sufficient amount of high grade lubricant for the life of the unit under normal operating conditions, therefore, no further lubrication is required.

EXTENSION CORDS

The use of any extension cord will cause some loss of power. To keep the loss to a minimum and to prevent tool overheating, follow the recommended cord sizes on the chart at right. When tool is used outdoors, use only extension cords suitable for outdoor use and so marked. Extension cords are available at Sears Retail Stores.

Extension Cord Length	Wire Size A.W.G.
25-50 Ft.	16
50-100 Ft.	14

⚠ WARNING: CHECK EXTENSION CORDS BEFORE EACH USE. IF DAMAGED, REPLACE IMMEDIATELY. NEVER USE TOOL WITH A DAMAGED CORD SINCE TOUCHING THE DAMAGED AREA COULD CAUSE ELECTRICAL SHOCK RESULTING IN SERIOUS INJURY.

CRAFTSMAN 3 INCH DUSTLESS BELT SANDER — MODEL NUMBER 315.117151

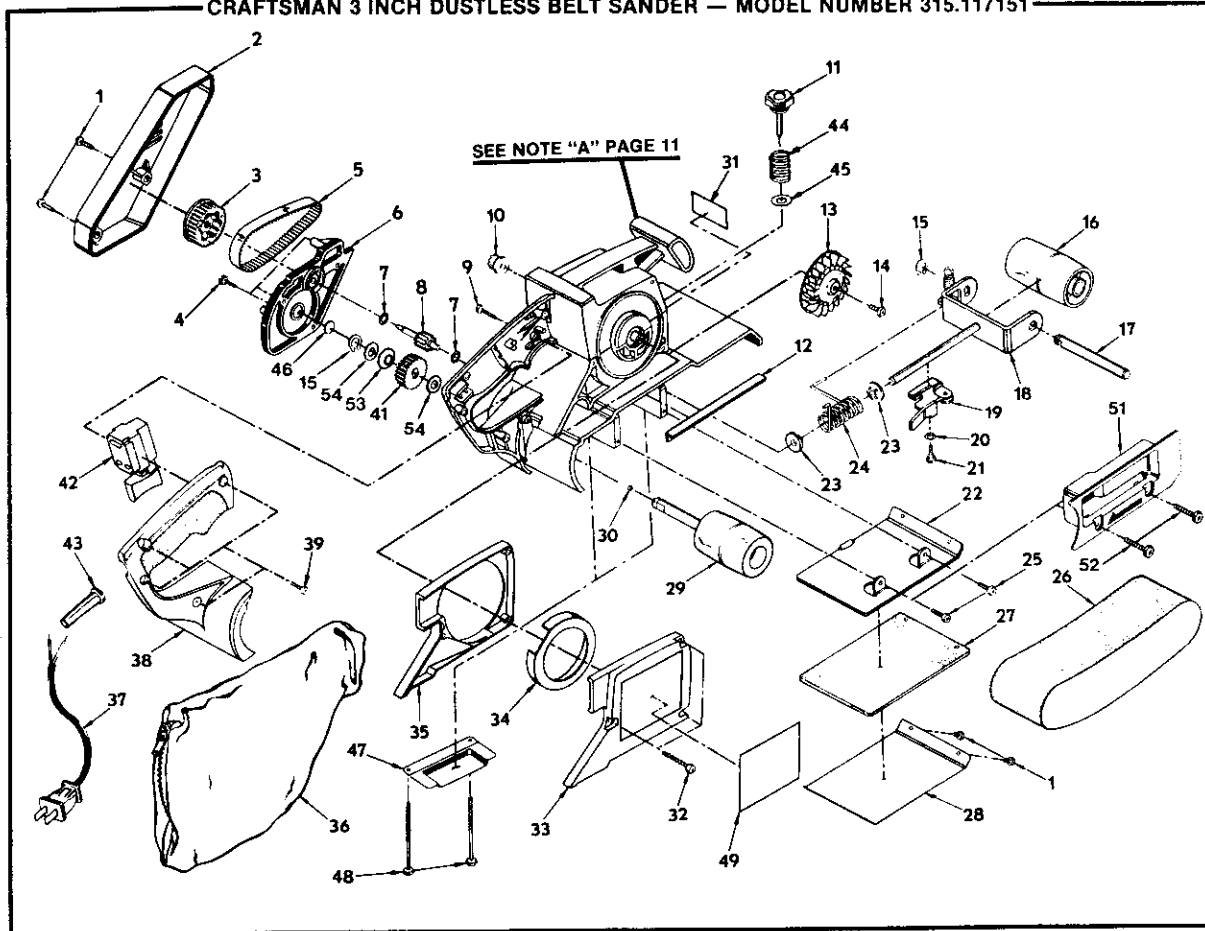

CRAFTSMAN 3 INCH DUSTLESS BELT SANDER — MODEL NUMBER 315.117151

The Model Number will be found on a plate attached to the Blower Cover of your Sander. Always mention the Model Number in all correspondence regarding your **CRAFTSMAN SANDER** or when ordering repair parts.

SEE BACK PAGE FOR PARTS ORDERING INSTRUCTIONS

PARTS LIST

KEY NO.	PART NUMBER	DESCRIPTION	QUAN.	KEY NO.	PART NUMBER	DESCRIPTION	QUAN.
1	610122-003	*Screw (#8-32 x 3/8 In. Pan Hd. T.C.)	4	28	998380-001	Wear Plate	1
2	998367-001	Belt Cover	1	29	999942-001	Drive Roller Assembly	1
3	607778-002	Driven Pulley	1	30	703774-003	Steel Ball	1
4	726693-020	*Screw (#8-32 x 3/8 In. Fil. Hd.)	3	31	981548-001	Data Plate	1
5	989368-000	Timing Belt	1	32	989592-001	*Screw (#8-10 x 1-1/8 In. Fil. Hd.)	3
6	998366-004	Gear Housing Cover w/Bearings	1	33	999931-001	Blower Cover	1
7	703493-809	Washer	2	34	998393-001	Shroud	1
8	998423-002	Pinion	1	35	998398-001	Blower Housing	1
9	726693-004	*Screw (#8-32 x 7/8 In. Fil. Hd.)	1	36	998394-006	Dust Bag Assembly	1
10	989366-000	Pulley	1	37	990493-006	Cord	1
11	998372-001	Tracking Knob	1	38	999929-001	Handle Cover	1
12	999448-003	Wear Strip	1	39	617966-009	*Screw (8-10 x 5/8 In. Pan Hd.)	4
13	999937-001	Blower	1	41	998368-001	Gear	1
14	998401-001	*Screw (#10-32 x 3/8 In. Washer Hd.)	1	42	998895-001	Switch	1
15	662167-012	Retaining Ring	2	43	613651-001	Bend Relief	1
16	998373-002	Idler Roller w/Bearings	1	44	616247-001	Spring	1
17	999954-002	Idler Roller Shaft	1	45	931744-818	Washer	1
18	999945-004	Yoke Assembly with Spring	1	46	616103-301	Thrust Washer	1
19	999927-001	Release Lever Assembly	1	47	999347-001	Deflector	1
20	622347-001	Washer	1	48	989592-007	*Screw (#8-10 x 2-1/4 In. Fil. H.D.)	2
21	999923-001	*Screw (#10-32 x 1/2 In. Pan Hd.)	1	49	981547-001	Logo Plate	1
22	998376-002	Platen	1	51	967878-003	Glamor Plate	1
23	998370-001	Bushing	2	52	612665-006	*Screw (#10-32 x 7/8 In. Pan Hd. T.F.) For use with Key No. 51 only	2
24	998371-001	Torsion Spring	1	53	622347-003	Spring Washer	1
25	612665-005	*Screw (#10-32 x 1/2 In. Pan Hd. T.F.)	2	54	622448-000	Washer	2
26	***	Sanding Belt (3 In. x 21 In.)	1		612547-530	Owner's Manual	
27	998378-001	Backing Pad	1				

NOTE: "A" — The assembly shown represents an important part of the Double Insulated System. To avoid the possibility of alteration or damage to the system service should be performed by your nearest Sears Repair Center. Contact your nearest Retail Store.

*Standard Hardware Item — May Be Purchased Locally
**Available From Div. 98 — Source 980.00

***Sanding Belts in assorted grits for both sanding wood and metal may be obtained from your nearest Sears Retail Store.

Get it fixed, at your home or ours!

For repair of major brand appliances **in your own home...**
no matter who made it, no matter who sold it!

1-800-4-MY-HOMESM Anytime, day or night
(1-800-469-4663)

www.sears.com

To bring in products such as vacuums, lawn equipment and electronics
for repair, call for the location of your nearest **Sears Parts & Repair Center.**

1-800-488-1222 Anytime, day or night

www.sears.com

For the replacement parts, accessories and owner's manuals
that you need to do-it-yourself, call **Sears PartsDirectSM!**

1-800-366-PART 6 a.m. – 11 p.m. CST,
(1-800-366-7278) 7 days a week

www.sears.com/partsdirect

To purchase or inquire about a Sears Service Agreement:

1-800-827-6655

7 a.m. – 5 p.m. CST, Mon. – Sat.

Para pedir servicio de reparación a domicilio,
y para ordenar piezas con entrega a domicilio:

1-888-SU-HOGARSM
(1-888-784-6427)

Au Canada pour service en français:

1-877-LE-FOYERSM
(1-877-533-6937)

