

SEARS

**OWNER'S
MANUAL**

**MODEL NO.
917.255690**

Caution:
Read and follow
all Safety Rules
and Instructions
Before Operating
This Equipment

JAN 10 1992

3One
Convertible



CRAFTSMAN[®]

**14.0 HP OHV
ELECTRIC START
3 in One Convertible
42" MOWER DECK
6 SPEED TRANSAXLE
LAWN TRACTOR**

- Assembly
- Operation
- Customer Responsibilities
- Service and Adjustment
- Repair Parts



SAFETY RULES

Safe Operation Practices for Ride-On Mowers



IMPORTANT: THIS CUTTING MACHINE IS CAPABLE OF AMPUTATING HANDS AND FEET AND THROWING OBJECTS. FAILURE TO OBSERVE THE FOLLOWING SAFETY INSTRUCTIONS COULD RESULT IN SERIOUS INJURY OR DEATH.

I. GENERAL OPERATION

- Read, understand, and follow all instructions in the manual and on the machine before starting.
- Only allow responsible adults, who are familiar with the instructions, to operate the machine.
- Clear the area of objects such as rocks, toys, wire, etc., which could be picked up and thrown by the blade.
- Be sure the area is clear of other people before mowing. Stop machine if anyone enters the area.
- Never carry passengers.
- Do not mow in reverse unless absolutely necessary. Always look down and behind before and while backing.
- Be aware of the mower discharge direction and do not point it at anyone. Do not operate the mower without either the entire grass catcher or the guard in place.
- Slow down before turning.
- Never leave a running machine unattended. Always turn off blades, set parking brake, stop engine, and remove keys before dismounting.
- Turn off blades when not mowing.
- Stop engine before removing grass catcher or unclogging chute.
- Mow only in daylight or good artificial light.
- Do not operate the machine while under the influence of alcohol or drugs.
- Watch for traffic when operating near or crossing roadways.
- Use extra care when loading or unloading the machine into a trailer or truck.

II. SLOPE OPERATION

Slopes are a major factor related to loss-of-control and tipover accidents, which can result in severe injury or death. All slopes require extra caution. If you cannot back up the slope or if you feel uneasy on it, do not mow it.

DO:

- Mow up and down slopes, not across.
- Remove obstacles such as rocks, tree limbs, etc.
- Watch for holes, ruts, or bumps. Uneven terrain could overturn the machine. *Tall grass can hide obstacles.*
- Use slow speed. Choose a low gear so that you will not have to stop or shift while on the slope.
- Follow the manufacturer's recommendations for wheel weights or counterweights to improve stability.
- Use extra care with grass catchers or other attachments. These can change the stability of the machine.
- Keep all movement on the slopes *slow and gradual*. Do not make sudden changes in speed or direction.
- Avoid starting or stopping on a slope. If tires lose traction, disengage the blades and proceed slowly *straight* down the slope.

DO NOT:

- *Do not* turn on slopes unless necessary, and then, turn slowly and gradually downhill, if possible.
- *Do not* mow near drop-offs, ditches, or embankments. The mower could suddenly turn over if a wheel is over the edge of a cliff or ditch, or if an edge caves in.
- *Do not* mow on wet grass. Reduced traction could cause sliding.
- *Do not* try to stabilize the machine by putting your foot on the ground.
- *Do not* use grass catcher on steep slopes.

III. CHILDREN

Tragic accidents can occur if the operator is not alert to the presence of children. Children are often attracted to the machine and the mowing activity. *Never* assume that children will remain where you last saw them.

- Keep children out of the mowing area and under the watchful care of another responsible adult.
- Be alert and turn machine off if children enter the area.
- Before and when backing, look behind and *down* for small children.
- Never carry children. They may fall off and be seriously injured or interfere with the safe machine operation.
- Never allow children to operate the machine.
- Use extra care when approaching blind corners, shrubs, trees, or other objects that may obscure vision.

IV. SERVICE

- Use extra care in handling gasoline and other fuels. They are flammable and vapors are explosive.
 - Use only an approved container.
 - Never remove gas cap or add fuel with the engine running. Allow engine to cool before refueling. Do not smoke.
 - Never refuel the machine indoors.
 - Never store the machine or fuel container inside where there is an open flame, such as a water heater.
- Never run a machine inside a closed area.
- Keep nuts and bolts, especially blade attachment bolts, tight and keep equipment in good condition.
- Never tamper with safety devices. Check their proper operation regularly.
- Keep machine free of grass, leaves, or other debris build-up. Clean oil or fuel spillage. Allow machine to cool before storing.
- Stop and inspect the equipment if you strike an object. Repair, if necessary, before restarting.
- Never make adjustments or repairs with the engine running.
- Grass catcher components are subject to wear, damage, and deterioration, which could expose moving parts or allow objects to be thrown. Frequently check components and replace with manufacturer's recommended parts, when necessary.
- Mower blades are sharp and can cut. Wrap the blade(s) or wear gloves, and use extra caution when servicing them.
- Check brake operation frequently. Adjust and service as required.



Look for this symbol to point out important safety precautions. It means CAUTION!!! BECOME ALERT!!! YOUR SAFETY IS INVOLVED.



CAUTION: Always disconnect spark plug wire and place wire where it cannot contact spark plug in order to prevent accidental starting when setting up, transporting, adjusting or making repairs.

CONGRATULATIONS on your purchase of a Sears Tractor. It has been designed, engineered and manufactured to give you the best possible dependability and performance.

Should you experience any problem you cannot easily remedy, please contact your nearest Sears Service Center/Department. We have competent, well-trained technicians and the proper tools to service or repair this unit.

Please read and retain this manual. The instructions will enable you to assemble and maintain your unit properly. Always observe the "SAFETY RULES".

MODEL NUMBER	917.255690
SERIAL NUMBER	_____
DATE OF PURCHASE	_____
THE MODEL AND SERIAL NUMBERS WILL BE FOUND ON A PLATE UNDER THE SEAT.	
YOU SHOULD RECORD BOTH SERIAL NUMBER AND DATE OF PURCHASE AND KEEP IN A SAFE PLACE FOR FUTURE REFERENCE.	

MAINTENANCE AGREEMENT

A Sears Maintenance Agreement is available on this product. Contact your nearest Sears store for details.

CUSTOMER RESPONSIBILITIES

- Read and observe the safety rules.
- Follow a regular schedule in maintaining, caring for and using your unit.
- Follow the instructions under "Customer Responsibilities" and "Storage" sections of this owner's manual.

PRODUCT SPECIFICATIONS

HORSEPOWER:	14.0
GASOLINE CAPACITY:	3.5 GALLONS UNLEADED REGULAR
OIL (3.0 PINTS) (3.5 PINTS)	SAE 30 (Above 32°F) 5W-30 (Below 32°F)
SPARK PLUG (GAP .030 IN.):	CHAMPION RC12YC
VALVE CLEARANCE:	INTAKE .0015 - .0030 IN. EXHAUST .0020 - .0035 IN.
GROUND SPEED:	FORWARD 1st 1.10 MPH 2nd 1.40 MPH 3rd 2.00 MPH 4th 3.00 MPH 5th 4.20 MPH 6th 5.00 MPH REVERSE: 1.50 MPH
TIRE PRESSURE:	FRONT: 14 PSI REAR: 10 PSI
CHARGING SYSTEM:	3 AMPS BATTERY 5 AMPS HEADLIGHTS
BLADE BOLT TORQUE:	30-35 FT. LBS.

WARNING: This unit is equipped with an internal combustion engine and should not be used on or near any unimproved forest-covered, brush-covered or grass-covered land unless the engine's exhaust system is equipped with a spark arrester meeting applicable local or state laws (if any). If a spark arrester is used, it should be maintained in effective working order by the operator.

In the state of California the above is required by law (Section 4442 of the California Public Resources Code). Other states may have similar laws. Federal laws apply on federal lands. A spark arrester for the muffler is available through your nearest Sears Authorized Service Center (See REPAIR PARTS section of this manual).

LIMITED TWO YEAR WARRANTY ON ELECTRIC START RIDING EQUIPMENT

For two (2) years from the date of purchase, if this riding equipment is maintained, lubricated and tuned up according to the instructions in the owner's manual, Sears will repair or replace, free of charge, any parts found to be defective in material or workmanship.

This Warranty does not cover:

- Expendable items which become worn during normal use, such as blades, spark plugs, air cleaners and belts.
- Tire replacement or repair caused by punctures from outside objects, such as nails, thorns, stumps, or glass.
- Repairs necessary because of operator abuse, negligence, improper storage or accident or the failure to maintain the equipment according to the instructions contained in the owner's manual.
- Riding equipment used for commercial or rental purposes.

LIMITED 90 DAY WARRANTY ON BATTERY

For 90 days from date of purchase, if any battery included with this riding equipment proves defective in material or workmanship and our testing determines the battery will not hold a charge, Sears will replace the battery at no charge.

WARRANTY SERVICE IS AVAILABLE BY RETURNING THE RIDING EQUIPMENT TO THE NEAREST SEARS SERVICE CENTER/DEPARTMENT IN THE UNITED STATES.

This Warranty gives you specific legal rights, and you may also have other rights which may vary from state to state.

SEARS, ROEBUCK AND CO., D/731CR-W, SEARS TOWER, CHICAGO, ILLINOIS 60684

TABLE OF CONTENTS

SAFETY RULES	2	OPERATION	11-14
PRODUCT SPECIFICATIONS	3	MAINTENANCE SCHEDULE	15
CUSTOMER RESPONSIBILITIES	3, 15-19	SERVICE AND ADJUSTMENTS	20-24
WARRANTY	3	STORAGE	25
TABLE OF CONTENTS	4	TROUBLESHOOTING	26-27
INDEX	4	REPAIR PARTS - TRACTOR	30-45
TRACTOR ACCESSORIES	5	REPAIR PARTS - ENGINE	46-51
ASSEMBLY	7-10	PARTS ORDERING/SERVICE	BACK PAGE





INDEX

A		E		Operation		11-14
Accessories	5	Electrical:		Operating Mower	13	
Adjustments:		Schematic	28	Options:		
Brake	22	Wiring Diagram	30	Accessories	5	
Carburetor	24	Engine:		Spark Arrester	3,40	
Mower		Air Filter	18	P		
Front-To-Back	21	Air Filter Foam Pre-Cleaner	18	Parking Brake	11-12	
Side-To-Side	21	Air Screen	18	Parts Bag	6	
Throttle Control Cable	24	Oil Change	17	Parts, Replacement/Repair	30-45	
Air Filter, Engine	18	Oil Level	13,17	Product Specifications	3	
Air Screen, Engine	18	Oil Type	17	R		
Assembly	7-10	Preparation	13	Repair Parts	30-45	
B		Repair Parts	46-51	S		
Battery:		Starting	14	Safety Rules	2	
Charging	8	Storage	25	Seat	8	
Cleaning	17	F		Service and Adjustments	20-24	
Installation	9	Filter:		Carburetor	24	
Levels	8,17	Air Filter	18	Fuse	23	
Preparation	8	Air Filter Foam Pre-Cleaner	18	Motion Drive Belt		
Starting with Weak Battery	23	Fuel	19	Removal/Replacement	22	
Storage	25	Fuel:		Mower Blade Drive Belt		
Terminals	17	Type	13	Removal/Replacement	22	
Belt:		Storage	25	Mower Adjustment		
Motion Drive		Fuse	23	Front- to-Back	21	
Removal/Replacement	22	L		Side-to-Side	21	
Mower Blade Drive		Leveling Mower Deck	21	Mower Removal	20	
Removal/Replacement	22	Lubrication:		Tire Care	8,16,23	
Blade:		Chart	15	Slope Guide Sheet	55	
Sharpening	16	M		Spark Plugs	19	
Replacement	16	Maintenance Schedule	15	Specifications	3	
Brake Adjustment	22	Mower:		Starting the Engine	13-14	
C		Adjustment, Front-to-Back	21	Steering Wheel	7,22	
Carburetor Adjustment	24	Adjustment, Side-to-Side	21	Stopping the Tractor	12	
Controls, Tractor	11	Blade Sharpening	16	Storage	25	
Customer Responsibilities	15-19	Blade Replacement	16	T		
Engine:		Cutting Height	12	Throttle Control Cable		
Air Filter	18	Installation	20	Adjustment	24	
Air Filter Foam Pre-Cleaner	18	Operation	13	Tires	8,16,23	
Air Screen, Engine	18	Removal	20	Trouble Shooting Chart	26-27	
Battery	17	Mowing Tips	14	Transaxle:		
Engine Oil	17	Muffler	19	Repair Parts	44-45	
Fuel Filter	19	Spark Arrester	3,40	W		
Spark Plugs	19	Mulcher Plate	10	Warranty	3	
Tractor:		O		Wiring Diagram	30	
Blade	16	Oil:		Wiring Schematic	28	
Lubrication Chart	15	Cold Weather Conditions	13,17			
Maintenance Schedule	15	Engine	17			
Tire Care	8,16,23	Storage	25			
Cutting Height, Mower	12					

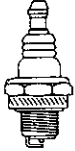
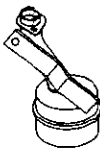
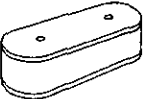

ACCESSORIES AND ATTACHMENTS

These accessories and attachments were available when the unit was purchased. They are also available at most Sears retail outlets, catalog and service centers. Most Sears stores can order these items for you when you provide the model number of your tractor.

ENGINE

SPARK PLUG	MUFFLER	AIR FILTER	GAS CAN	ENGINE OIL	STABILIZER
					

MAINTENANCE

BLADES	BELTS
	

PERFORMANCE

Sears offers a wide variety of attachments that fit your vehicle. Many of these are listed below with brief explanations of how they can help you. This list was current at the time of publication; however, it may change in future years - more attachments may be added, changes may be made in these attachments, or some may no longer be available or fit your model. **Contact your nearest Sears store for the accessories and attachments that are available for your unit.**

Most of these attachments do not require additional hitches or conversion kits (those that do are indicated) and are designed for easy attaching and detaching.

PERMANEX BAGGER lets you collect grass clippings and leaves for a healthier, neater looking lawn. Two Permanex containers hold 30-gallon plastic bags.

LAWN SWEEPERS let you collect grass clippings and leaves.

LAWN VACS for powerful collection of heavy grass clippings and leaves. Wand attachment to pick up debris in hard-to-reach places.

CARTS make hauling easy. Variety of sizes available.

ROLLER for smoother lawn surface. 36-inch wide, 18-inch diameter water-tight drum holds up to 390 lbs. of weight. Rounded edges prevent harm to turf. Adjustable scraper automatically cleans drum.

SPREADER/SEEDERS make seeding, fertilizing, and weed killing easy. Broadcast spreaders are also useful for granular de-icers and sand.

CORING AERATOR takes small plugs out of soil to allow moisture and nutrients to reach grass roots. 36-inch swath. 24 hardened steel coring tips. 150 lb. capacity weight tray.

AERATOR promotes deep root growth for a healthy lawn. Tapered 2.5-inch steel spikes mounted on 10-inch diameter discs puncture holes in soil at close intervals to let moisture soak in. Steel weight tray for increased penetration.

MULCH RAKE/DETHATCHER loosens soil and flips thatch and matted leaves to lawn surface for easy pickup. Twenty spring tine teeth. Useful to prepare bare areas for seeding. Available for front or rear mounting.

SPRAYERS use 12-volt DC electric motor that connects to the tractor battery or other 12-volt source. Includes booms for automatic spraying when pulling, and hand held wand for spot spraying. Wand has adjustable spray pattern. For applying herbicides, insecticides, fungicides, and liquid fertilizers.

SNOW BLADE for snow removal only. 14-inch high, 42-inch wide blade clears 38-inch path when angled left or right. Raises, lowers with side lever. Adjustable skids; replaceable, reversible scraper bar. (Use with tire chains, wheel weights, or rear drawbar weight.)

SNOWTHROWER has 40-inch swath. Drum-type auger handles powdery and wet/heavy snow. Mounts easily with simple pin arrangement. Discharge chute adjusts from tractor seat. 6-inch diameter spout discharges snow 10 to 50 feet. Lift controlled at tractor seat. (Use with chains, wheel weights, or rear drawbar weight.)

TIRE CHAINS are heavy duty; closely spaced extra-large cross links give smooth ride, outstanding traction.

WHEEL WEIGHTS for rear wheels provide needed traction for snow removal or dozing heavy materials. In pairs. (30 lbs. each.)

TRACTOR CAB has heavy duty vinyl fabric over tubular steel frame, ABS plastic top; clear plastic windshield offers 360 degree visibility. Hinged metal doors with catch. Keeps operator warm and dry. Remove vinyl and windshields for use as sun protector in summer. (Catalog only.)

Optional accessories for tractor cab: tinted/tempered solid safety glass windshield with hand operated wiper; 12-volt amber caution light for mounting on cab top. (Catalog only.)

TRACTOR COVER protects tractor from weather. Made of Evolution 3 fabric (water-repellent, extremely breathable, light weight, soft, non-abrasive, pliable in all temperatures, durable, stain/tear/puncture resistant, will not shrink or stretch.) (Catalog only.)

TILLER has 5 hp engine and 36-inch swath to prepare seed beds, cultivate, and compost garden residue. Tiller has its own built-in lift and depth control system and does NOT require a sleeve hitch. Fits any lawn, yard, or garden tractor. Simply hook up to the tractor drawbar and go!

CONTENTS OF HARDWARE PACK

Parts Bag contents shown full size

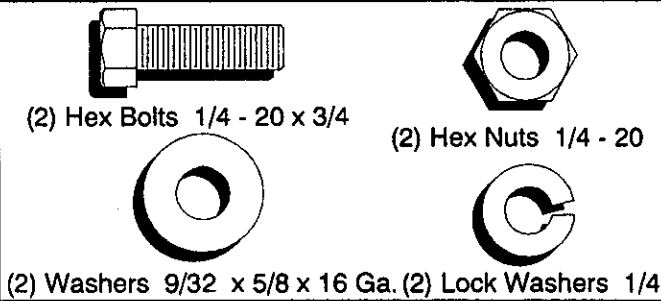
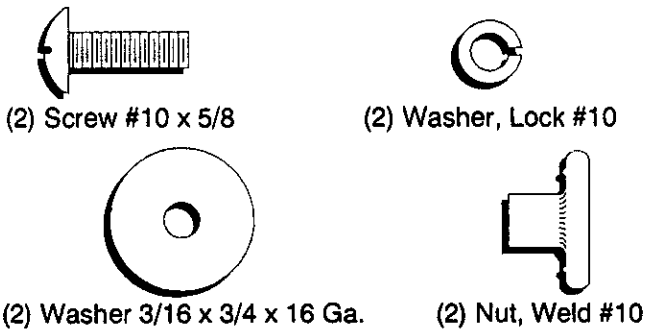
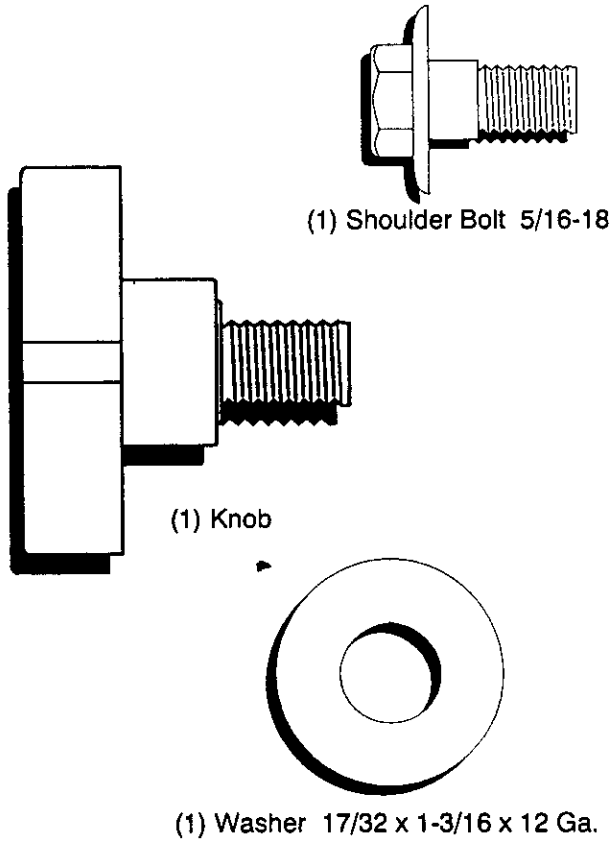

Parts packed separately in carton

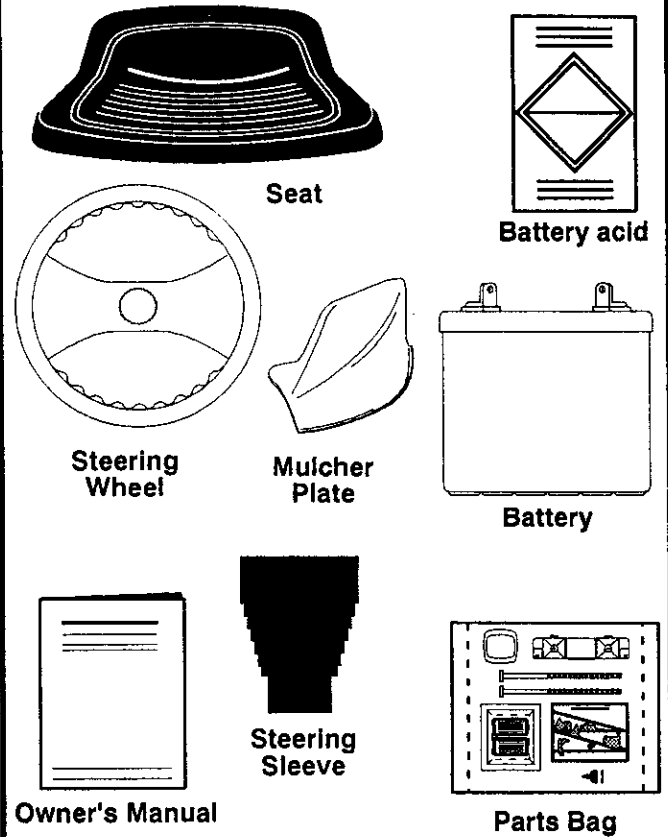

Parts bag contents not shown full size

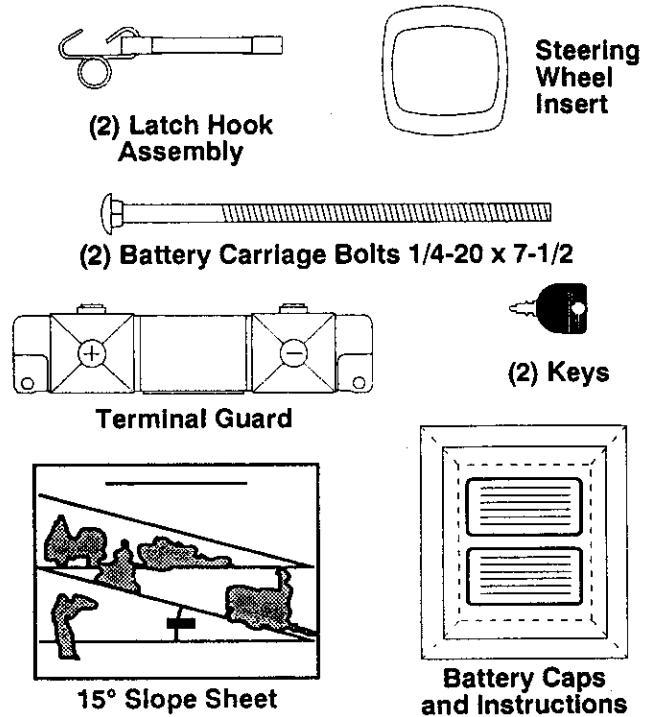

ASSEMBLY

TOOLS REQUIRED FOR ASSEMBLY

A socket wrench set will make assembly easier. Standard wrench sizes are listed.

- | | |
|--------------------|---------------------------------|
| (2) 7/16" wrenches | (1) Tire pressure gauge |
| (1) Screwdriver | (1) 3/4" Socket w/drive ratchet |
| (1) 1/2" wrench | (1) Utility Knife |

When right and left hand is mentioned in this manual, it means when you are in the operating position (seated behind the steering wheel).

TO REMOVE UNIT FROM CARTON UNPACK CARTON

- Remove all accessible loose parts and parts cartons from carton (See page 6).
- Cut along dotted lines on the carton, from top to bottom, all four corners of carton and lay panels flat.
- Check for any additional loose parts or cartons and remove.

BEFORE ROLLING UNIT OFF SKID ATTACH STEERING WHEEL (See Fig. 1)

- Remove hex locknut and large flat washer from steering shaft.
- Position front wheels of the tractor so they are pointing straight forward.
- Position steering sleeve over steering shaft.
- Position steering wheel so cross bars are horizontal (left to right) and slide onto adapter.
- Secure steering wheel to steering shaft with hex locknut and large flat washer previously removed. Tighten securely.
- Snap insert into center of steering wheel.
- Remove protective plastic from tractor hood and grill.

IMPORTANT: CHECK FOR AND REMOVE ANY STAPLES IN SKID THAT MAY PUNCTURE TIRES WHERE UNIT IS TO ROLL OFF SKID.

(See Fig. 2)

- Raise attachment lift lever to its highest position.
- Release parking brake by depressing clutch/brake pedal.
- Place gearshift lever in "NEUTRAL" position.
- Roll unit backwards off skid.
- Remove banding holding discharge guard up against tractor.

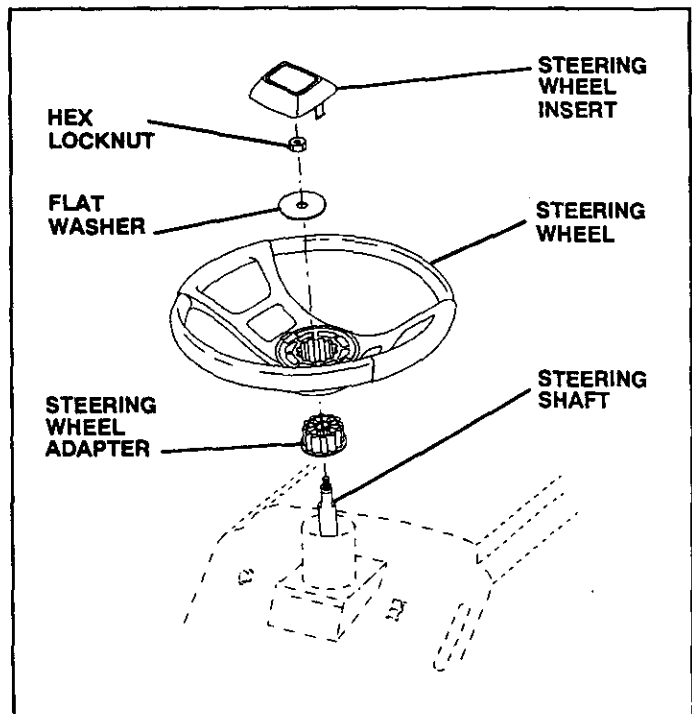

FIG. 1

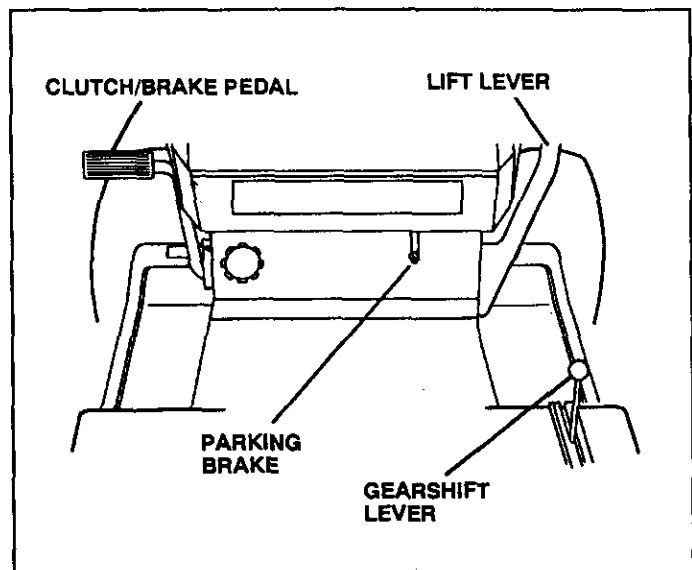
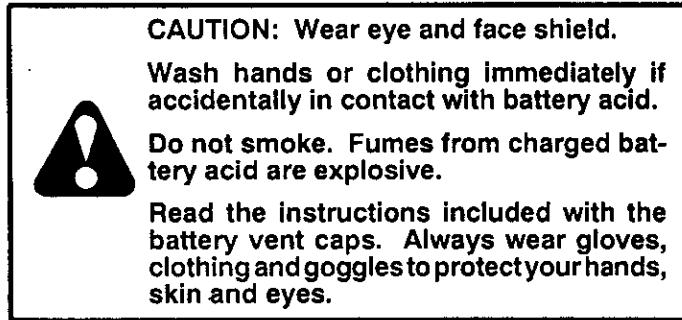

FIG. 2

ASSEMBLY

HOW TO SET UP YOUR TRACTOR PREPARE BATTERY (See Fig. 3)



Your unit has a battery charging system which is sufficient for normal use. However, periodic charging of the battery with an automotive charger will extend its life.

- See instructions packed with vent caps in parts bag.
- Fill battery with acid. Fill each cell until it reaches the bottom of the vent wells. Do not overfill.
- Allow battery to stand and settle for at least thirty minutes. After standing, check the level of acid. If below the vent wells, add more acid until the correct level is reached.

While battery is standing (after adding acid) and later, while battery is being charged, continue with assembly of unit.

IMPORTANT: TO MAXIMIZE THE LIFE OF YOUR BATTERY, IT IS NECESSARY THAT THE BATTERY BE CHARGED BEFORE USE. FAILURE TO CHARGE BATTERY CAN RESULT IN A SHORTENED BATTERY LIFE.

- Charge battery at a rate of 6 amperes for 1 hour. Use a 12 volt battery charger. Observe all safety precautions required for battery charging.
- Check the acid level after the battery is charged. If the acid has fallen below the correct level, add distilled or iron free water.
- Install the vent caps to cover the vent wells. Wash the top of the battery with water to remove any acid, then wipe dry.
- Check battery case for leakage to make sure that no damage has occurred in handling.
- Dispose of excess battery acid. Neutralize acid for disposal by adding it to four inches of water in a five gallon plastic container. Stir with a wooden or plastic paddle while adding baking soda until the addition of more soda causes no more foaming.
- Follow instructions on how to install battery.

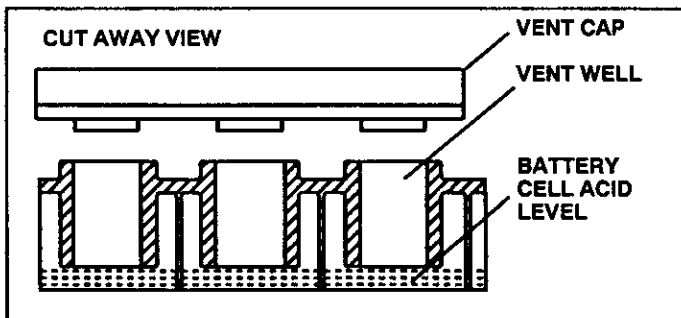

FIG. 3

INSTALL SEAT (See Fig. 4)

Adjust seat before tightening adjustment knob.

- Remove cardboard packing on seat pan.
- Place seat on pan and assemble shoulder bolt.
- Assemble adjustment knob and flat washer loosely. Do not tighten.
- Tighten shoulder bolt securely.
- Lower seat into operating position and sit on seat.
- Slide seat until a comfortable position is reached which allows you to press clutch/brake pedal all the way down.
- Get off seat without moving its adjusted position.
- Raise seat and tighten adjustment knob securely.

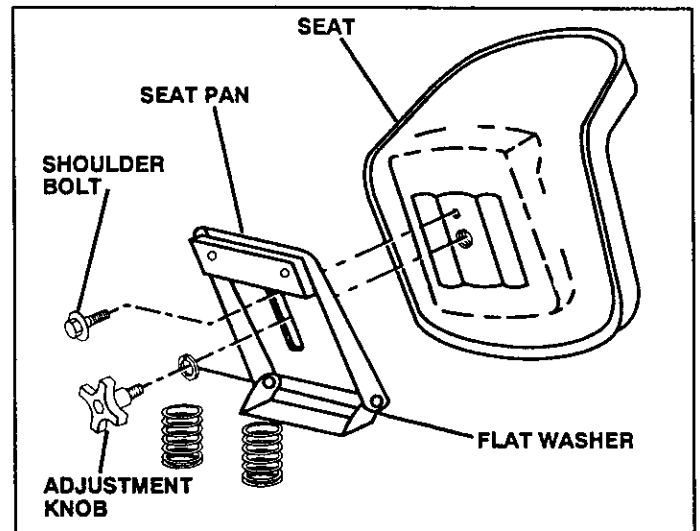

FIG. 4

CHECK TIRE PRESSURE

The tires on your unit were overinflated at the factory for shipping purposes. Correct tire pressure is important for best cutting performance.

- Reduce tire pressure to PSI shown in "PRODUCT SPECIFICATIONS" on page 3 of this manual.

CHECK DECK LEVELNESS

For best cutting results, mower housing should be properly leveled. See "TO LEVEL MOWER HOUSING" in the Service and Adjustments section of this manual.

CHECK FOR PROPER POSITION OF ALL BELTS

See the figures that are shown for replacing motion, mower drive, and mower blade drive belts in the Service and Adjustments section of this manual. Verify that the belts are routed correctly.

ASSEMBLY

CHECK BRAKE SYSTEM

After you learn how to operate your tractor, check to see that the brake is properly adjusted. See "TO ADJUST BRAKE" in the Service and Adjustments section of this manual.

INSTALL BATTERY (See Figs. 5 and 6)



CAUTION: Do not short battery terminals. Before installing battery, remove metal bracelets, wristwatch bands, rings, etc.

Positive terminal must be connected first to prevent sparking from accidental grounding.

- Raise hood.
- Make sure drain tube is fastened to drain hole in battery tray and battery tray is positioned in hole of battery support.
- Place battery in plastic tray, battery terminals to front of tractor.
- First connect RED battery cable to positive (+) battery terminal with hex bolt, flat washer, lock washer and hex nut. Tighten securely.
- Connect BLACK grounding cable to negative (-) battery terminal with remaining hex bolt, flat washer, lock washer and hex nut. Tighten securely.
- Slide the two battery bolts through the terminal guard and start the wing nuts onto the threads.
- Position terminal guard over the battery as shown, lower bolts into key holes and slide square shafts of bolts into slots of key holes.
- Tighten wing nuts by hand making sure battery bolts remain in slots of the key holes in the battery support.
- Be sure terminal access doors are closed.

Use terminal access doors for:

- Inspection for secure connections (to tighten hardware).
- Inspection for corrosion.
- Testing battery.
- Jumping (if required).
- Periodic charging.

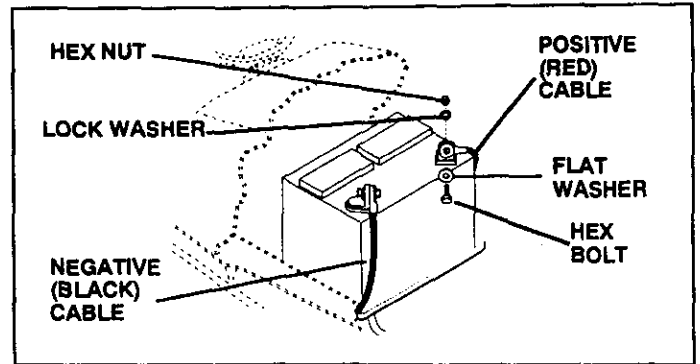

FIG. 5

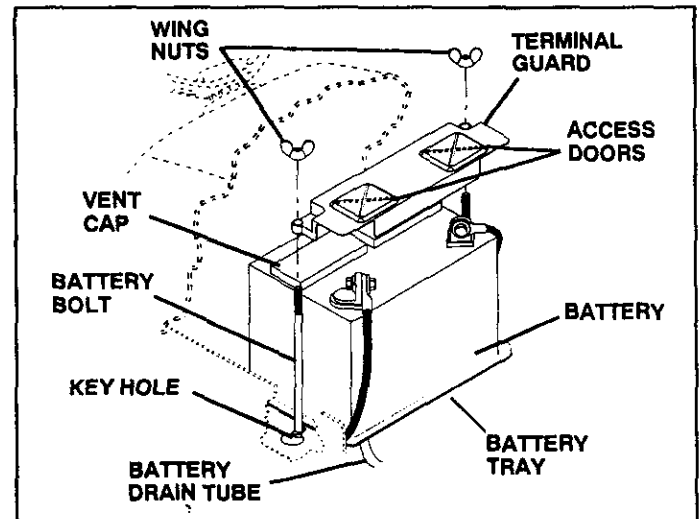

FIG. 6

ASSEMBLY

INSTALL MULCHER PLATE

(See Figs. 7 & 8)

- Install two latch hook assemblies, to mulcher plate using screw, washer, lock washer, and weld nut as shown.
- Tighten hardware securely.
- Raise and hold deflector shield in upright position.
- Place front of mulcher plate over front of mower deck opening and slide into place, as shown.
- Hook front latch into tab hole on front of mower deck.
- Hook rear latch into tab hole on back of mower deck.



CAUTION: Do not remove discharge guard from mower. Raise and hold guard when attaching mulcher plate and allow it to rest on plate while in operation.

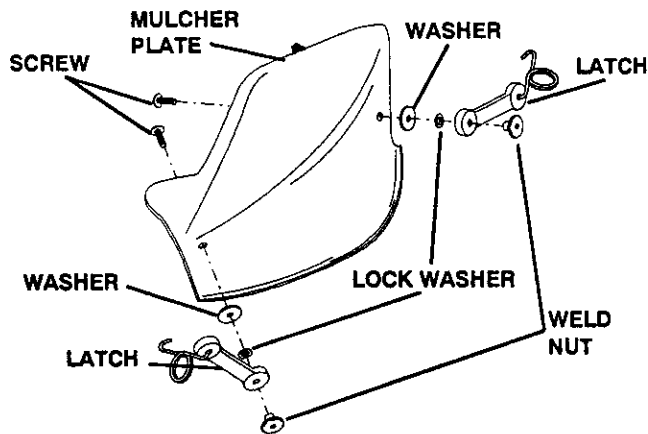

FIG. 7

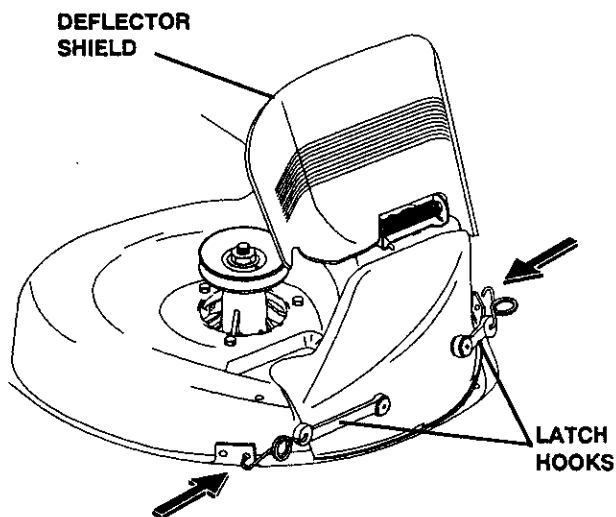

FIG. 8

TO CONVERT TO BAGGING OR DISCHARGING

Simply remove mulcher plate and store in a safe place. Your mower is now ready for discharging or installation of optional grass catcher accessory.

✓ CHECKLIST

BEFORE YOU OPERATE AND ENJOY YOUR NEW TRACTOR, WE WISH TO ASSURE THAT YOU RECEIVE THE BEST PERFORMANCE AND SATISFACTION FROM THIS QUALITY PRODUCT.

PLEASE REVIEW THE FOLLOWING CHECKLIST:

- ✓ All assembly instructions have been completed.
- ✓ No remaining loose parts in carton.
- ✓ Battery is properly prepared and charged. (Minimum 1 hour at 6 amps).
- ✓ Seat is adjusted comfortably and tightened securely.
- ✓ All tires are properly inflated. (For shipping purposes, the tires were over-inflated at the factory).
- ✓ Be sure mower deck is properly leveled side-to-side/ front-to-rear for best cutting results. (Tires must be properly inflated for leveling).
- ✓ Check mower and drive belts. Be sure they are routed properly around pulleys and inside all belt keepers.
- ✓ Check wiring. See that all connections are still secure and wires are properly clamped.

WHILE LEARNING HOW TO USE YOUR TRACTOR, PAY EXTRA ATTENTION TO THE FOLLOWING IMPORTANT ITEMS:

- ✓ Engine oil is at proper level.
- ✓ Fuel tank is filled with fresh, clean, regular unleaded gasoline.
- ✓ Become familiar with all controls - their location and function. Operate them before you start the engine.
- ✓ Be sure brake system is in safe operating condition.

OPERATION

KNOW YOUR TRACTOR

READ THIS OWNER'S MANUAL AND SAFETY RULES BEFORE OPERATING YOUR TRACTOR.

Compare the illustrations with your Tractor to familiarize yourself with the location of various controls and adjustments. Save this manual for future reference.

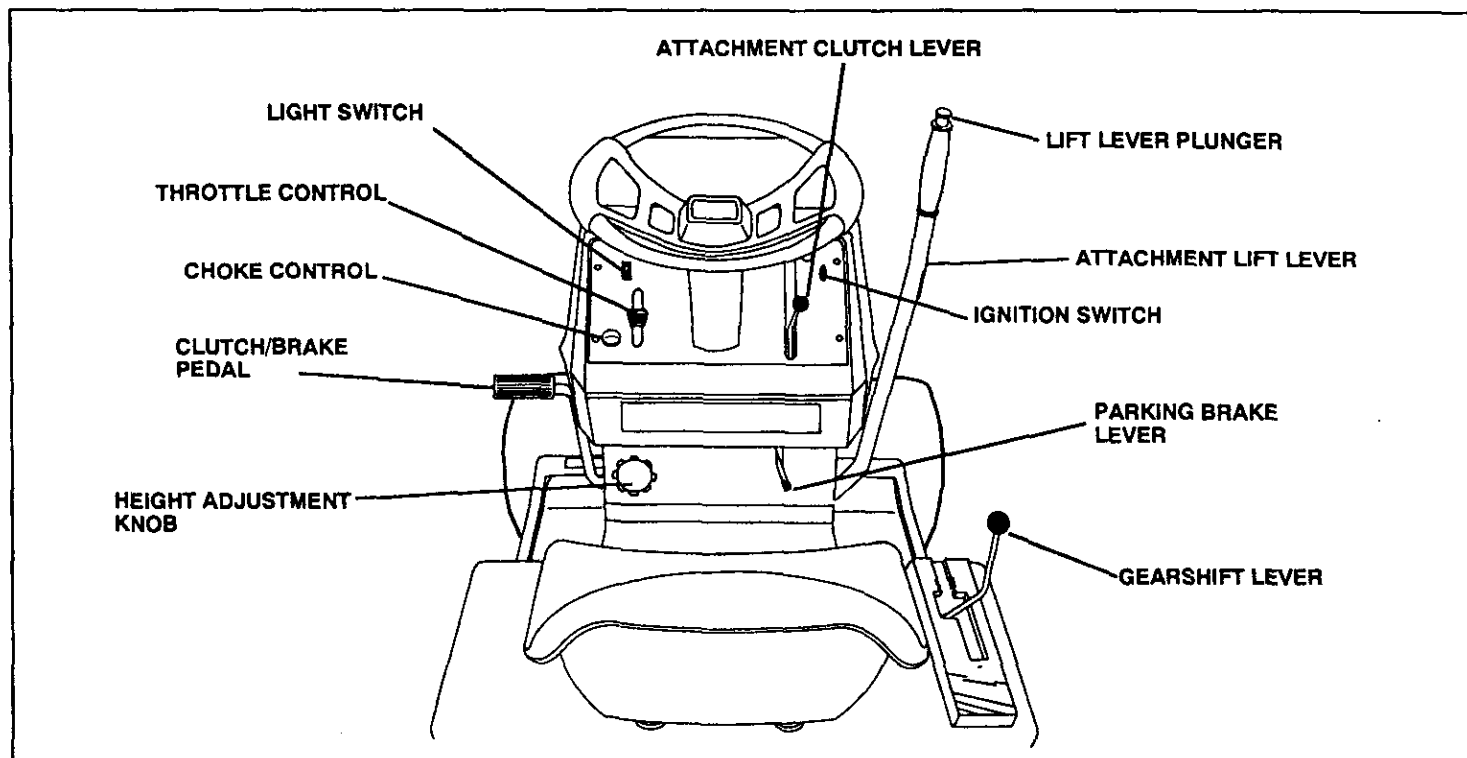

FIG. 9

Sears tractors conform to the safety standards of the American National Standards Institute.

ATTACHMENT CLUTCH LEVER - Used to engage mower blades or other attachments mounted to your tractor.

ATTACHMENT LIFT LEVER - Used to raise and lower mower deck or other attachments mounted to your tractor.

CLUTCH/BRAKE PEDAL - Used for declutching and braking the tractor and starting the engine.

HEIGHT ADJUSTMENT KNOB - Used to adjust the mower height.

GEARSHIFT LEVER - Selects the speed and direction of the tractor.

IGNITION SWITCH - Used to start and stop the engine.

LIGHT SWITCH - Turns the headlights on and off.

PARKING BRAKE LEVER - Locks clutch/brake pedal into the brake position.

THROTTLE CONTROL - Used to control engine speed.

CHOKE CONTROL - Used when starting a cold engine.

LIFT LEVER PLUNGER - Used to release attachment lift lever when changing its position.

OPERATION



The operation of any tractor can result in foreign objects thrown into the eyes, which can result in severe eye damage. Always wear safety glasses or eye shields before starting your tractor and while moving. We recommend Wide Vision Safety Mask for over the spectacles or standard safety glasses.

HOW TO USE YOUR TRACTOR TO SET PARKING BRAKE (See Fig. 10)

- Depress clutch/brake pedal into full "BRAKE" position and hold.
- Place parking brake lever in "ENGAGED" position and release pressure from clutch/brake pedal. Pedal should remain in "BRAKE" position. Make sure parking brake will hold vehicle secure.

STOPPING (See Fig. 10)

MOWER BLADES -

- Move attachment clutch lever to "DISENGAGED" position.

GROUND DRIVE -

- Depress clutch/brake pedal into full "BRAKE" position.
- Move gearshift lever to "NEUTRAL" position.

ENGINE -

- Move Throttle Control to "SLOW" position.
- Turn ignition key to "OFF" position and remove key. Always remove key when leaving vehicle to prevent unauthorized use.
- Never use choke to stop engine.

NOTE: Under certain conditions when unit is standing idle with the engine running, hot engine exhaust gasses may cause "browning" of grass. To eliminate this possibility, always stop engine when stopping unit on grass areas.



CAUTION: Always stop unit completely, as described above, before leaving the operator's position; to empty grass catcher, etc.

TO USE CHOKE CONTROL (See Fig. 10)

Use choke control whenever you are starting a cold engine. Do not use to start a warm engine.

- To engage choke control, pull knob out. Slowly push knob in to disengage.

TO USE THROTTLE CONTROL (See Fig. 10)

Always operate engine at full throttle.

- Operating engine at less than full throttle reduces the battery charging rate and the engine cooling air flow.
- Full throttle offers the best mower performance.

TO MOVE FORWARD AND BACKWARD (See Fig. 10)

The direction and speed of movement is controlled by the gearshift lever.

- Start tractor with clutch/brake pedal depressed and gearshift lever in "NEUTRAL" position.

- Move gearshift lever to desired position.
 - Slowly release clutch/brake pedal to start movement.
- IMPORTANT:** BRING TRACTOR TO A COMPLETE STOP BEFORE SHIFTING OR CHANGING GEARS. FAILURE TO DO SO WILL SHORTEN THE USEFUL LIFE OF YOUR TRANSAXLE.

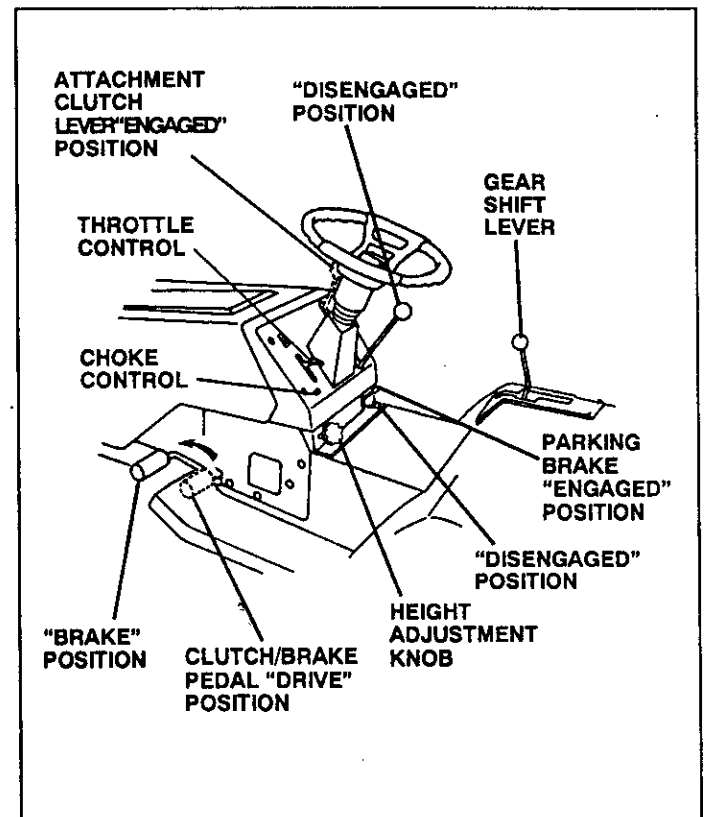

FIG. 10

TO ADJUST MOWER CUTTING HEIGHT (See Fig. 10)

The cutting height is controlled by turning the height adjustment knob in desired direction.

- Turn knob clockwise to raise cutting height.
- Turn knob counterclockwise to lower cutting height.

The cutting height range is approximately 1-1/4" to 3-3/4". The heights are measured from the ground to the blade tip with the engine not running. These heights are approximate and may vary depending upon soil conditions, height of grass and types of grass being mowed.

- The average lawn should be cut approximately 2-1/2 inches during the cool season and over 3 inches during hot months. For healthier and better looking lawns, mow often and after moderate growth.
- For best cutting performance, grass over 6 inches in height should be mowed twice. Make the first cut relatively high; the second to desired height.

OPERATION

TO OPERATE MOWER (See Fig. 9)

Your unit is equipped with an operator presence sensing switch. Any attempt by the operator to leave the seat with the engine running and the mower clutch engaged will shut off the engine.

- Select desired height of cut, using height adjustment knob.
- Lower mower with lift lever.
- Engage mower by slowly moving mower clutch lever to "ENGAGED" position.
- TO STOP MOWER - Move mower clutch lever to "DISENGAGED" position.



CAUTION: Do not operate the mower without either the entire grass catcher, on mowers so equipped, or the discharge guard in place.

TO OPERATE ON HILLS



CAUTION: Do not drive up or down hills with slopes greater than 15° and do not drive across any slope.

- Choose the slowest speed before starting up or down hills.
- Avoid stopping or changing speed on hills.
- If slowing is necessary, move throttle control lever to slower position.
- If stopping is absolutely necessary, push clutch/brake pedal quickly to brake position and engage parking brake.
- Move gearshift lever to "NEUTRAL" position.
- To restart movement, move gearshift lever to 1st gear. Be sure you have allowed room for unit to roll slightly as you restart movement.
- Slowly release parking brake and clutch/brake pedal.
- Make all turns slowly.

TO TRANSPORT

- Raise attachment lift control to highest position.
- When pushing or towing your unit, be sure gearshift lever is in "NEUTRAL" position.
- Do not push unit at more than five (5) MPH.

BEFORE STARTING THE ENGINE CHECK ENGINE OIL LEVEL

- The engine in your unit has been shipped, from the factory, already filled with summer weight oil.
- Check engine oil with unit on level ground.
- Unthread and remove the oil fill cap/dipstick; wipe oil off. Reinsert the dipstick into the tube and rest the oil fill cap on the tube. Do not thread the cap onto the tube. Remove and read oil level. If necessary, add oil until "FULL" mark on dipstick is reached. Do not overfill.
- For cold weather operation you should change oil for easier starting (see "OIL VISCOSITY CHART" in the Customer Responsibilities section of this manual).
- To change engine oil, see the Customer Responsibilities section in this manual.

ADD GASOLINE

- Fill fuel tank. Use fresh, clean, regular unleaded gasoline. (Use of leaded gasoline will increase carbon and lead oxide deposits and reduce valve life).

IMPORTANT: WHEN OPERATING IN TEMPERATURES BELOW 32°F(0°C), USE FRESH, CLEAN WINTER GRADE GASOLINE TO HELP INSURE GOOD COLD WEATHER STARTING.

WARNING: Experience indicates that alcohol blended fuels (called gasohol or using ethanol or methanol) can attract moisture which leads to separation and formation of acids during storage. Acidic gas can damage the fuel system of an engine while in storage. To avoid engine problems, the fuel system should be emptied before storage of 30 days or longer. Drain the gas tank, start the engine and let it run until the fuel lines and carburetor are empty. Use fresh fuel next season. See Storage Instructions for additional information. Never use engine or carburetor cleaner products in the fuel tank or permanent damage may occur.



CAUTION: Fill to bottom of gas tank filler neck. Do not overfill. Wipe off any spilled oil or fuel. Do not store, spill or use gasoline near an open flame.

OPERATION

TO START ENGINE (See Fig. 10)

When starting engine for the first time or if engine has run out of fuel, it will take extra cranking time to move fuel from the tank to the engine.

- Depress the clutch/brake pedal and set the parking brake.
- Place gearshift lever in "NEUTRAL" position.
- Move attachment clutch to "DISENGAGED" position.
- Pull choke control out to "CHOKE" position for cold engine start. For warm engine start do not use choke control.
- Move throttle control to midway between "FAST" and "SLOW" positions.
- Turn ignition key clockwise to "START" position and release key as soon as engine starts. Do not run starter continuously for more than fifteen seconds per minute. If engine does not start after several attempts, move throttle control to "FAST" position, wait a few minutes and try again.
- When engine starts, slowly push choke control in.
- Move throttle control to "FAST" position.
- Allow engine to warm up for a few minutes before engaging clutch/brake pedal or attachment clutch lever.

NOTE: If at a high altitude (above 3000 feet) or in cold temperatures (below 32° F), the carburetor fuel mixture may need to be adjusted for best engine performance. See "TO ADJUST CARBURETOR" in the Service and Adjustments section of this manual.

MOWING TIPS

- Tire chains cannot be used when the mower housing is attached to unit.
- Mower should be properly leveled for best mowing performance. See "TO LEVEL MOWER HOUSING" in the Service and Adjustments section of this manual.
- The left hand side of mower should be used for trimming.
- Drive so that clippings are discharged onto the area that has been cut. Have the cut area to the right of the machine. This will result in a more even distribution of clippings and more uniform cutting.
- When mowing large areas, start by turning to the right so that clippings will discharge away from shrubs, fences, driveways, etc. After one or two rounds, mow in the opposite direction making left hand turns until finished (See Fig. 11).

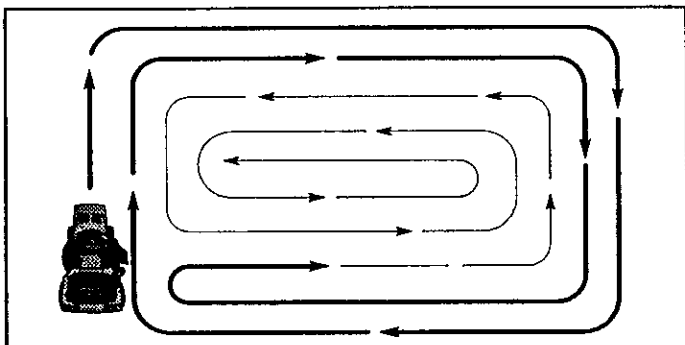

FIG. 11

- If grass is extremely tall, it should be mowed twice to reduce load and possible fire hazard from dried clippings. Make first cut relatively high; the second to the desired height.
- Do not mow grass when it is wet. Wet grass will plug mower and leave undesirable clumps. Allow grass to dry before mowing.
- Always operate engine at full throttle when mowing to assure better mowing performance and proper discharge of material. Regulate ground speed by selecting a low enough gear to give the mower cutting performance as well as the quality of cut desired.
- When operating attachments, select a ground speed that will suit the terrain and give best performance of the attachment being used.

MULCHING MOWING TIPS

IMPORTANT: FOR BEST PERFORMANCE, KEEP MOWER HOUSING FREE OF BUILT-UP GRASS AND TRASH. CLEAN AFTER EACH USE.

- The special mulching blade will recut the grass clippings many times and reduce them in size so that as they fall onto the lawn they will disperse into the grass and not be noticed. Also, the mulched grass will biodegrade quickly to provide nutrients for the lawn. Always mulch with your highest engine (blade) speed as this will provide the best recutting action of the blades.
- Avoid cutting your lawn when it is wet. Wet grass tends to form clumps and interferes with the mulching action. The best time to mow your lawn is the early afternoon. At this time the grass has dried and the newly cut area will not be exposed to the direct sun.
- For best results, adjust the mower cutting height so that the mower cuts off only the top one-third of the grass blades (See Fig. 12). For extremely heavy mulching, reduce your width of cut and mow slowly.

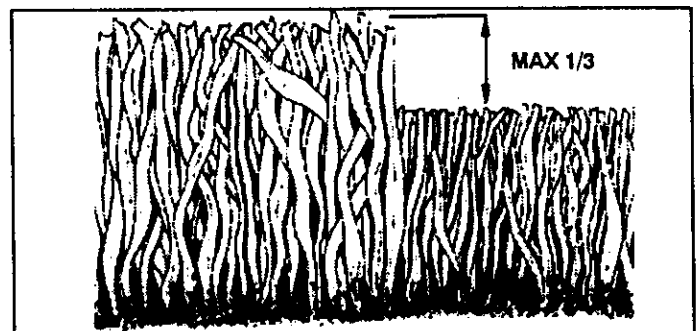

FIG. 12

- Certain types of grass and grass conditions may require that an area be mulched a second time to completely hide the clippings. When doing a second cut, mow across or perpendicular to the first cut path.
- Change your cutting pattern from week to week. Mow north to south one week then change to east to west the next week. This will help prevent matting and graining of the lawn.

CUSTOMER RESPONSIBILITIES

MAINTENANCE SCHEDULE FILL IN DATES AS YOU COMPLETE REGULAR SERVICE		SERVICE INTERVALS							SERVICE DATES		
		BEFORE EACH USE	FIRST 2 HOURS	EVERY 8 HOURS	EVERY 25 HOURS	EVERY 50 HOURS	EVERY 100 HOURS	EVERY SEASON			BEFORE STORAGE
TRACTOR	Check Brake Operation	✓	✓								
	Check Tire Pressure	✓	✓								
	Check for Loose Fasteners	✓						✓			
	Sharpen/Replace Mower Blades				✓ ⁴						
	Lubrication Chart				✓			✓			
	Check Battery Level/Recharge				✓						
	Clean Battery and Terminals				✓				✓		
	Check Transmission Cooling				✓						
	Adjust Blade Belt(s) Tension						✓				
	Adjust Motion Drive Belt(s) Tension						✓				
ENGINE	Check Engine Oil Level	✓	✓								
	Change Engine Oil		✓		✓ ^{1,2,3}			✓			
	Clean Air Filter				✓ ²						
	Clean Air Screen				✓ ²						
	Inspect Muffler/Spark Arrester					✓					
	Replace Oil Filter (if equipped)						✓ ^{1,2}				
	Clean Engine Cooling Fins						✓ ²				
	Replace Spark Plug						✓	✓			
	Replace Air Filter Paper Cartridge						✓ ²				
	Replace Fuel Filter							✓			

1 - Change more often when operating under a heavy load or in high ambient temperatures.
2 - Service more often when operating in dirty or dusty conditions.

3 - If equipped with oil filter, change oil every 50 hours.
4 - Replace blades more often when mowing in sandy soil.

GENERAL RECOMMENDATIONS

The warranty on this vehicle does not cover items that have been subjected to operator abuse or negligence. To receive full value from the warranty, operator must maintain unit as instructed in this manual.

Some adjustments will need to be made periodically to properly maintain your unit.

All adjustments in the Service and Adjustments section of this manual should be checked at least once each season.

- Once a year you should replace the spark plug, clean or replace air filter, and check blades and belts for wear. A new spark plug and clean air filter assure proper air-fuel mixture and help your engine run better and last longer.

BEFORE EACH USE

- Check engine oil level.
- Check brake operation.
- Check tire pressure.
- Check for loose fasteners.

LUBRICATION CHART

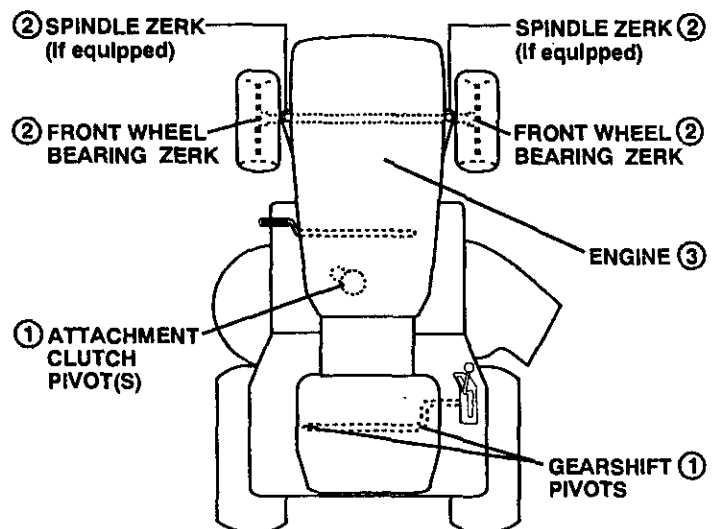

① SAE 30 MOTOR OIL API - SG

② GENERAL PURPOSE GREASE

③ REFER TO CUSTOMER RESPONSIBILITIES "ENGINE" SECTION

IMPORTANT: DO NOT OIL OR GREASE THE PIVOT POINTS WHICH HAVE SPECIAL NYLON BEARINGS. VISCOUS LUBRICANTS WILL ATTRACT DUST AND DIRT THAT WILL SHORTEN THE LIFE OF THE SELF-LUBRICATING BEARINGS. IF YOU FEEL THEY MUST BE LUBRICATED, USE ONLY A DRY, POWDERED GRAPHITE TYPE LUBRICANT SPARINGLY.

CUSTOMER RESPONSIBILITIES

TRACTOR

Always observe safety rules when performing any maintenance.

BRAKE OPERATION

If unit requires more than six (6) feet stopping distance at high speed in highest gear, than brake must be adjusted. (See "TO ADJUST BRAKE" in Service and Adjustments section of this manual).

TIRES

- Maintain proper air pressure in all tires (See "PRODUCT SPECIFICATIONS" on page 3 of this manual).
- Keep tires free of gasoline, oil, or insect control chemicals which can harm rubber.
- Avoid stumps, stones, deep ruts, sharp objects and other hazards that may cause tire damage.

BLADE CARE

For best results mower blades must be kept sharp. The blades can be sharpened with a file or on a grinding wheel. We suggest they be sharpened or replaced after every 25 hours of mowing. Check blades more often if mowing in sandy conditions.

- Do not attempt to sharpen blades while they are on the mower.
- Replace bent or damaged blades.

BLADE REMOVAL (See Fig. 13)

- Raise mower to highest position to allow access to blades.
- Remove hex bolt, lock washer and flat washer securing blade.
- Install new or resharpened blade with trailing edge up towards deck as shown.
- Reassemble hex bolt, lock washer and flat washer in exact order as shown.
- Tighten bolt securely (30-35 Ft. Lbs. torque).

IMPORTANT: BLADE BOLT IS GRADE 8 HEAT TREATED.

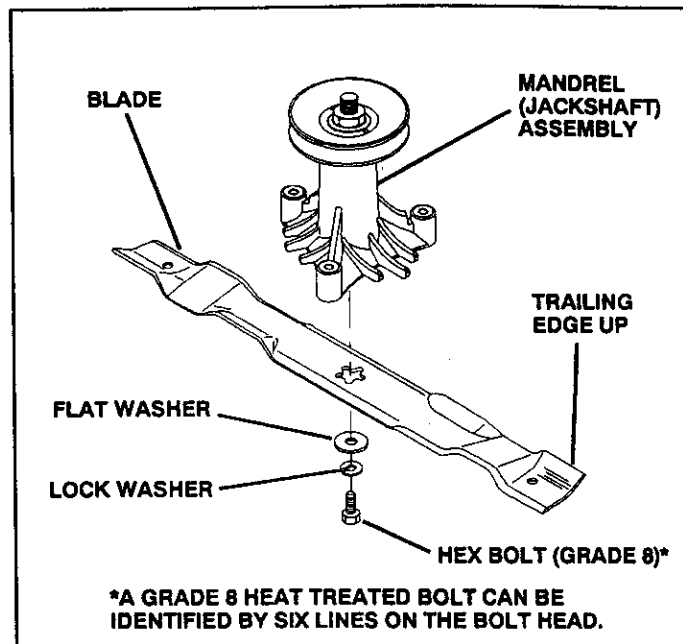

FIG. 13

TO SHARPEN BLADE (See Fig. 14)

Care should be taken to keep the blade balanced. An unbalanced blade will cause excessive vibration and eventual damage to mower and engine.

- The blade can be sharpened with a file or on a grinding wheel. Do not attempt to sharpen while on the mower.
- To check blade balance, you will need a 5/8" diameter steel bolt, pin, or a cone balancer. (When using a cone balancer, follow the instructions supplied with balancer).
- Slide blade on to an unthreaded portion of the steel bolt or pin and hold the bolt or pin parallel with the ground. If blade is balanced, it should remain in a horizontal position. If either end of the blade moves downward, sharpen the heavy end until the blade is balanced.

NOTE: Do not use a nail for balancing blade. The lobes of the center hole may appear to be centered, but are not.

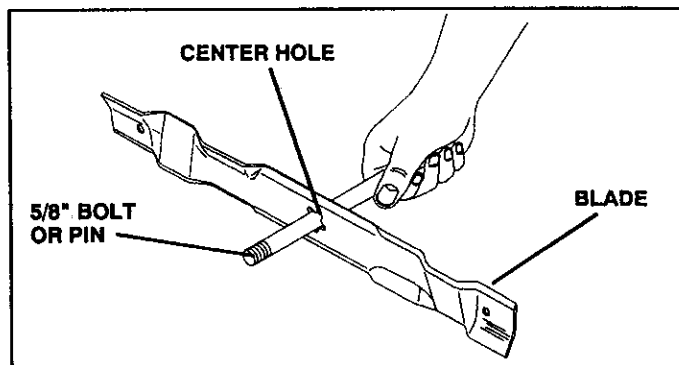

FIG. 14

CUSTOMER RESPONSIBILITIES

BATTERY (See Fig. 15)

Your unit has a battery charging system which is sufficient for normal use. However, periodic charging of the battery with an automotive charger will extend its life.

- Acid solution level in each battery cell should be even with bottoms of vent wells. Add only distilled or iron free water if necessary. Do not overfill.

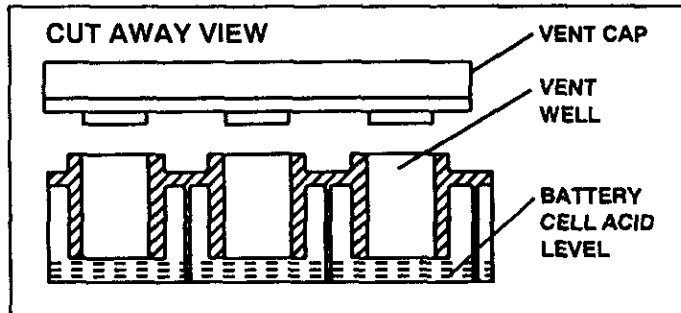

FIG. 15

- Keep battery and terminals clean.
- Keep battery bolts tight.
- Keep vent caps tight and small vent holes in caps open.
- Recharge at 6 amperes for 1 hour.

TO CLEAN BATTERY AND TERMINALS -

Corrosion and dirt on the battery and terminals can cause the battery to "leak" power.

- Remove terminal guard.
- Disconnect BLACK battery cable first then RED battery cable and remove battery from tractor.
- Wash battery with solution of four tablespoons of baking soda to one gallon of water. Be careful not to get the soda solution into the cells.
- Rinse the battery with plain water and dry.
- Clean terminals and battery cable ends with wire brush until bright.
- Coat terminals with grease or petroleum jelly.
- Reinstall battery (See "INSTALL BATTERY" in the Assembly section of this manual).

V-BELTS

Check V-belts for deterioration and wear after 100 hours and replace if necessary. The belts are not adjustable. Replace belts if they begin to slip from wear.

TRANSAXLE COOLING

Keep transaxle free from build-up of dirt and chaff which can restrict cooling.

ENGINE

LUBRICATION

Only use high quality detergent oil rated with API service classification SG. Select the oil's SAE viscosity grade according to your expected operating temperature.

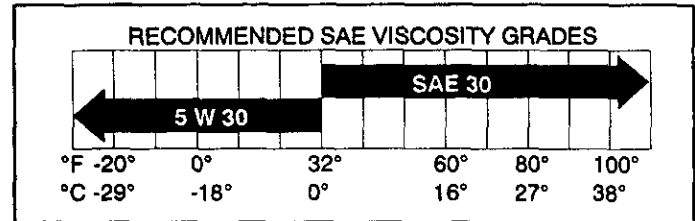

NOTE: Although multi-viscosity oils (5W30, 10W30 etc.) improve starting in cold weather, these multi-viscosity oils will result in increased oil consumption when used above 32°F. Check your engine oil level more frequently to avoid possible engine damage from running low on oil.

Change the oil after the first two hours of operation and every 50 hours thereafter or at least once a year if the tractor is not used for 50 hours in one year.

Check the crankcase oil level before starting the engine and after each eight (8) hours of continuous use. Tighten oil fill cap/dipstick securely each time you check the oil level.

TO CHANGE ENGINE OIL

- Be sure vehicle is on level surface.
- Oil will drain more freely when warm.
- Catch oil in a suitable container.
- Remove oil fill dipstick. Be careful not to allow dirt to enter the engine when changing oil.
- Remove drain plug.
- After oil has drained completely, replace oil drain plug and tighten securely.
- Refill engine with oil through oil fill dipstick tube. Pour slowly. Do not overfill. For approximate capacity see Product Specifications on page 3 of this manual.
- Use gauge on oil fill dipstick for checking level. Do not thread the cap onto the tube when taking reading. Keep oil at "FULL" line on dipstick. Tighten cap onto the tube securely when finished.

CUSTOMER RESPONSIBILITIES

AIR FILTER FOAM PRE-CLEANER (See Fig. 16)

Your engine will not run properly and may be damaged by using a dirty air filter. Clean the foam pre-cleaner element after every 25 hours of operation, more often if tractor is used in very dusty, dirty conditions.

- Remove knob and cover.
- Remove foam pre-cleaner element by sliding it off of the paper cartridge.

NOTE: Do not attempt to clean or oil the paper cartridge. Replace paper cartridge once a year or after every 100 hours of operation; more often if used in very dusty or dirty conditions.

- Wash foam pre-cleaner in liquid detergent and water.
- Wrap foam pre-cleaner in cloth and squeeze dry.
- Lightly coat foam pre-cleaner with clean engine oil. Squeeze in towel to remove excess oil. Do not saturate.
- Install foam pre-cleaner over paper cartridge.
- Reassemble cover and tighten knob securely.

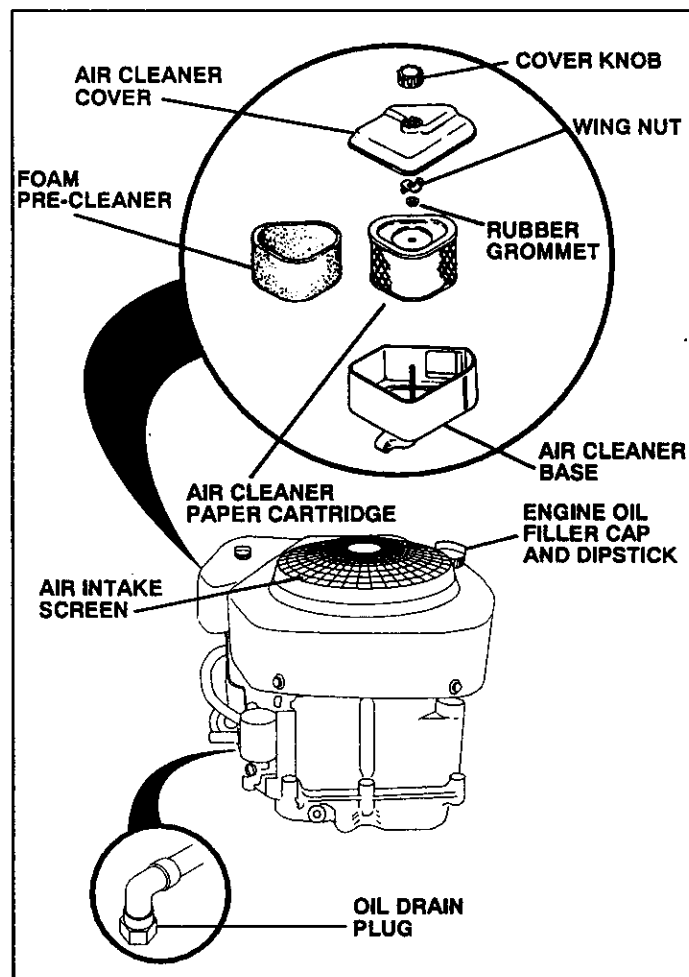

FIG. 16

CLEAN AIR INTAKE/COOLING AREAS (See Fig. 16)

To insure proper cooling, make sure the grass screen, cooling fins, and other external surfaces of the engine are kept clean at all times.

Every 100 hours of operation (more often under extremely dusty, dirty conditions), remove the blower housing and other cooling shrouds. Clean the cooling fins and external surfaces as necessary. Make sure the cooling shrouds are reinstalled.

NOTE: Operating the engine with a blocked grass screen, dirty or plugged cooling fins, and/or cooling shrouds removed, will cause engine damage due to overheating.

ENGINE OIL FILTER (See Fig. 17)

Replace the engine oil filter every season or every other oil change if the tractor is used more than 100 hours in one year.

- Drain oil from engine crankcase (See "TO CHANGE ENGINE OIL" through step remove drain plug).
- Remove oil filter drain plug located at base of oil filter adapter. Allow oil filter to drain.
- Remove oil filter and wipe off filter adapter. Reinstall oil filter drain plug.
- Apply a thin coating of new engine oil to the rubber gasket on replacement oil filter.
- Install replacement oil filter on filter adapter. Turn oil filter clockwise until rubber gasket contacts the filter adapter, then tighten filter an additional 1/2 turn.
- Fill crankcase with new oil (See "TO CHANGE ENGINE OIL" in this section of this manual). For approximate capacity see "PRODUCT SPECIFICATIONS" on page 3 of this manual.
- Start the engine and check for oil leaks. Correct any leaks before placing engine into full operation.

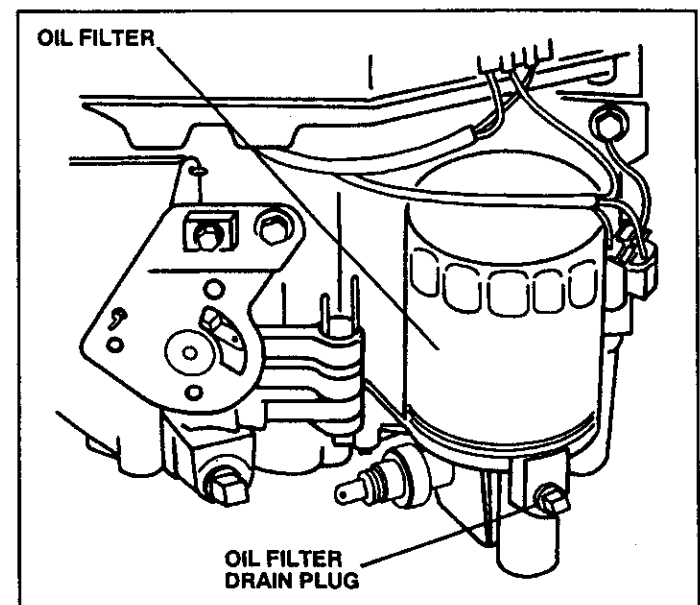

FIG. 17

CUSTOMER RESPONSIBILITIES

MUFFLER

Inspect and replace corroded muffler and spark arrester (if equipped) as it could create a fire hazard and/or damage.

SPARK PLUGS

Replace spark plugs at the beginning of each mowing season or after every 100 hours of use, whichever comes first. Spark plug type and gap setting is shown in "PRODUCT SPECIFICATIONS" on page 3 of this manual.

IN-LINE FUEL FILTER (See Fig. 18)

Fuel filter should be replaced once each season. If fuel filter becomes clogged, obstructing fuel flow to carburetor, replacement is required.

- With engine cool, remove filter and plug fuel line sections.
- Place new fuel filter in position in fuel line.
- Be sure there are no fuel line leaks and clamps are properly positioned.
- Immediately wipe up any spilled gasoline.

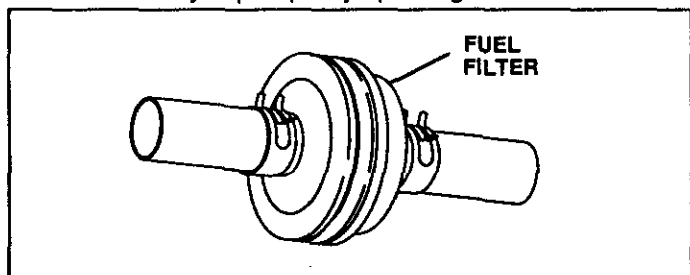

FIG. 18

CLEANING

IMPORTANT: FOR BEST PERFORMANCE, KEEP MOWER HOUSING FREE OF BUILD-UP, GRASS AND TRASH. CLEAN UNDERSIDE OF MOWER HOUSING AFTER EACH USE.

- Clean engine, battery, seat, finish, etc. of all foreign matter.
- Keep finished surfaces and wheels free of all gasoline, oil, etc.
- Protect painted surfaces with automotive type wax.

We do not recommend using a garden hose to clean your unit unless the electrical system, muffler, air filter and carburetor are covered to keep water out. Water in engine can result in a shortened engine life.

SERVICE AND ADJUSTMENTS



CAUTION: BEFORE PERFORMING ANY SERVICE OR ADJUSTMENTS:

- Depress clutch/brake pedal fully and set parking brake.
- Place gearshift lever in "NEUTRAL" position.
- Place attachment clutch in "DISENGAGED" position.
- Turn ignition key "OFF" and remove key.
- Make sure the blades and all moving parts have completely stopped.
- Disconnect spark plug wire from spark plug and place wire where it cannot come in contact with plug.

TRACTOR

TO REMOVE MOWER (See Fig. 19)

Mower will be easier to remove from the right side of unit.

- Place attachment clutch in "DISENGAGED" position.
- Move attachment lift lever forward to lower mower to its lowest position.
- Roll belt off engine pulley.
- Disconnect clutch rod from clutch lever by removing retainer spring.
- Disconnect suspension arms from rear deck brackets by removing retainer springs.
- Disconnect front links from deck by removing retainer springs.
- Raise lift lever to raise suspension arms. Slide mower out from under tractor.

IMPORTANT: IF AN ATTACHMENT OTHER THAN THE MOWER IS TO BE MOUNTED TO THE TRACTOR, BOTH SUSPENSION ARMS MUST BE REMOVED FROM TRACTOR. SEE CAUTION BELOW.



CAUTION: If the suspension arms are ever removed from tractor (which may be necessary for mounting other attachments and the like) the lift link on the left side of tractor must be removed from tractor if it is not needed or used with the attachment.

Failure to do so will allow the lift link to interfere with tractor steering which could cause loss of control while driving resulting in property damage and/or personal injury.

TO INSTALL MOWER (See Fig. 19)

- Raise attachment lift lever to its highest position.
- Slide mower under tractor with discharge guard to right side of tractor.
- Lower lift lever to its lowest position.
- Install mower in reverse order of removal instructions.

NOTE: The mower clutch rod has a trunnion that has been preset, at the factory, for optimum mower performance. DO NOT MOVE THE TRUNNION ON THE CLUTCH ROD. If for any reason the trunnion has been moved on the clutch rod, it must be reset to correct position (parallel with clutch rod) and measure 10-11/32" (Check dimension on edge of flat work surface as shown).

Be sure to tighten trunnion nut securely against trunnion after making any adjustments.

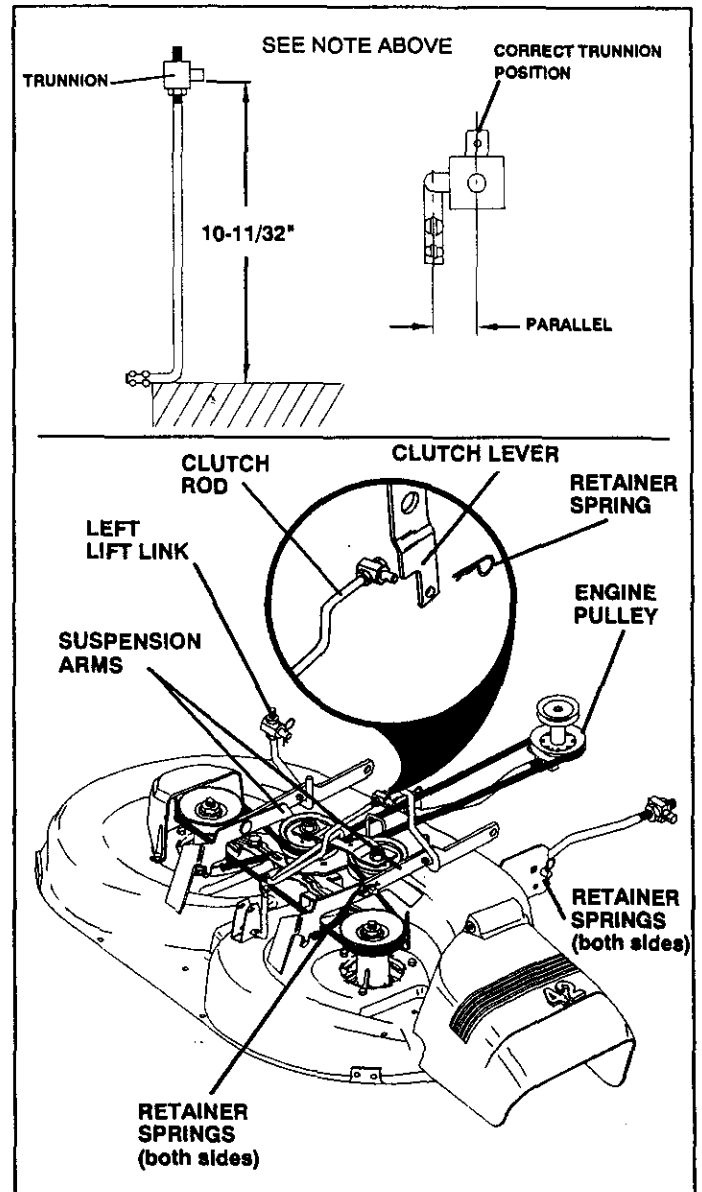

SERVICE AND ADJUSTMENTS

TO LEVEL MOWER HOUSING

Adjust the mower while tractor is parked on level ground or driveway. Make sure tires are properly inflated (See "PRODUCT SPECIFICATIONS" on page 3). If tires are over or under inflated, you will not properly adjust your mower.

SIDE-TO-SIDE ADJUSTMENT (See Figs. 20 and 21) -

- Raise attachment lift lever to its highest position.
- Measure height from bottom of deck curl to ground level at front corners of mower. Distance "A" should be the same.
- If distance "A" needs to be changed, snap out access hole cover on left side of tractor above footrest.
- To raise left side of mower, loosen nut "B" and tighten nut "C".
- To lower left side of mower, loosen nut "C" and tighten nut "B".
- When distance "A" is equal, securely tighten nuts "B" and "C".
- Replace access hole cover.

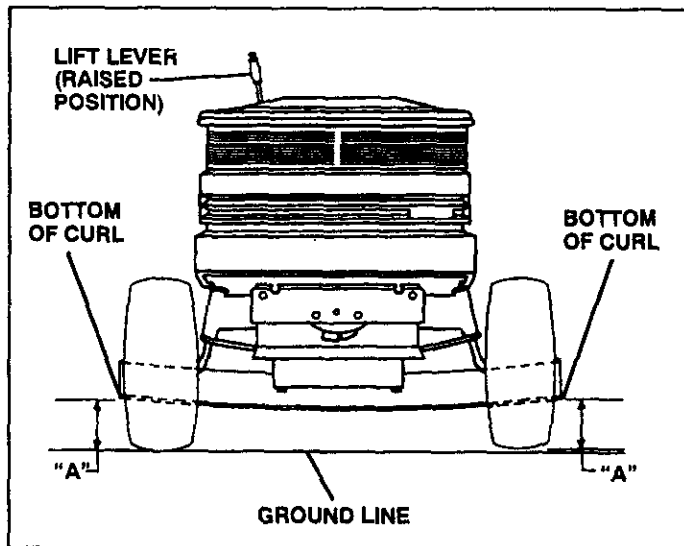

FIG. 20

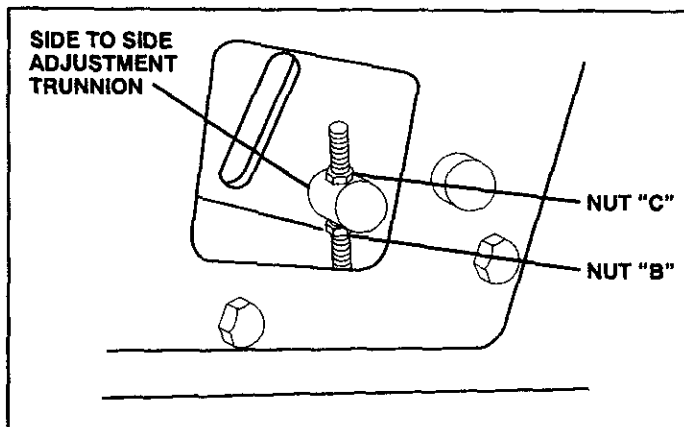

FIG. 21

FRONT-TO-BACK ADJUSTMENT (See Figs. 22 and 23) -
To obtain the best cutting results, the mower housing should be adjusted so that the front is approximately 1/4" to 1/2" lower than the rear when the mower is in its highest position.

Check adjustment on right side of tractor. Measure distance "D" directly in front and behind the mandrel at bottom edge of mower housing as shown.

- Before making any necessary adjustments, check that both front links are equal in length. Both links should be approximately 10-3/8".
- If links are not equal in length, adjust one link to same length as other link.

IMPORTANT: IF THE FOLLOWING FRONT-TO-BACK ADJUSTMENT IS NECESSARY, BE SURE TO ADJUST BOTH FRONT LINKS EQUALLY SO MOWER WILL STAY LEVEL SIDE-TO-SIDE.

- To lower front of mower turn nut "E" counterclockwise on both front links an equal number of turns.
- When distance "D" is 1/4" to 1/2" lower at front than rear, tighten nuts "F" against trunnion on both front links.
- To raise front of mower, loosen nut "F" from trunnion on both front links. Turn nut "E" clockwise on both front links an equal number of turns.
- When distance "D" is 1/4" to 1/2" lower at front than rear, retighten nut "F" against trunnion on both front links.
- Recheck side-to-side adjustment.

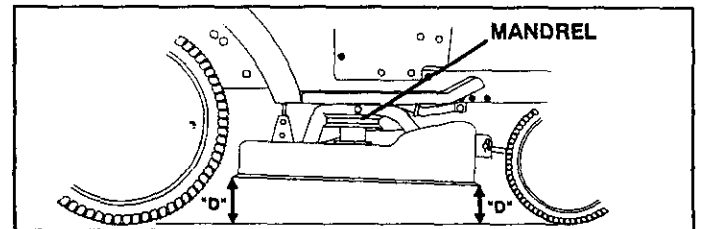

FIG. 22

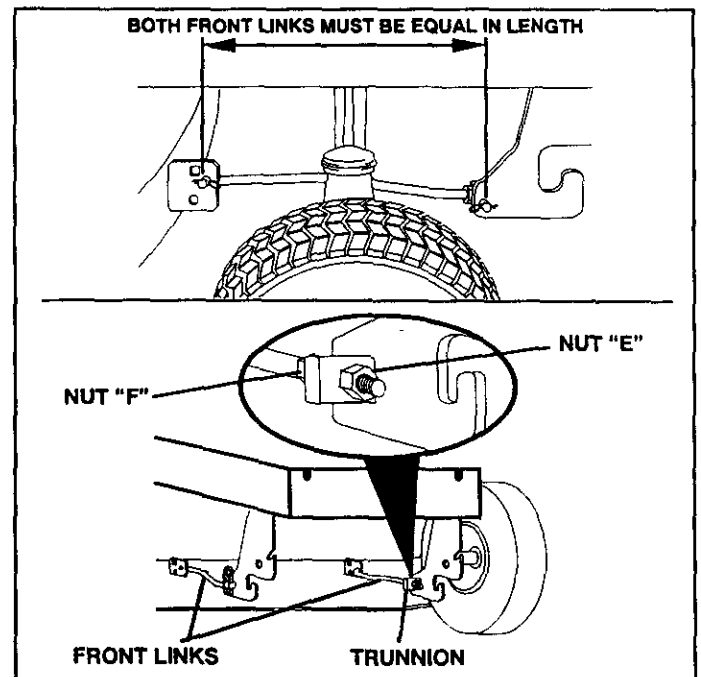

FIG. 23

SERVICE AND ADJUSTMENTS

TO REPLACE MOWER BLADE DRIVE BELT (See Fig. 24)

The mower blade drive belt may be replaced without tools. Park the tractor on level surface. Engage parking brake. For assistance, there is a belt installation guide decal on the mower housing.

BELT REMOVAL -

- Place attachment clutch in "DISENGAGED" position.
- Move attachment lift lever forward to lower mower to its lowest position.
- Roll belt off engine pulley.
- Work belt off both mandrel pulleys and idler pulleys.
- Pull belt away from mower.

BELT INSTALLATION -

- Install new belt in reverse order of removal.
- Make sure belt is in all pulley grooves and inside all belt guides.

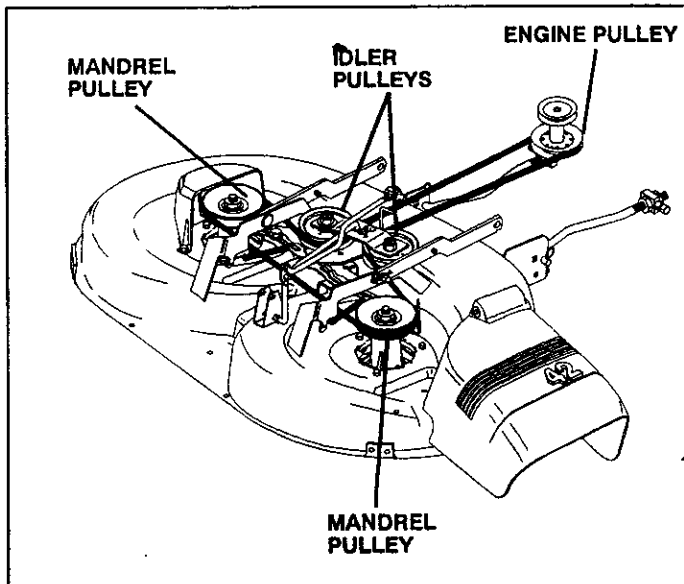

FIG. 24

TO ADJUST BRAKE (See Fig. 25)

Your unit is equipped with an adjustable brake system which is mounted on the right side of the transaxle.

If unit requires more than six (6) feet stopping distance at high speed in highest gear, then brake must be adjusted.

- Depress clutch/brake pedal and engage parking brake.
- Measure distance between brake operating arm and nut "A" on brake rod.
- If distance is other than 1-1/2", disengage parking brake, loosen jam nut and turn nut "A" until distance becomes 1-1/2". Retighten jam nut against nut "A".
- Engage parking brake and recheck distance.
- Road test unit for proper stopping distance as stated above. Readjust if necessary. If stopping distance is still greater than six (6) feet in highest gear, further maintenance is necessary. Contact your nearest authorized service center.

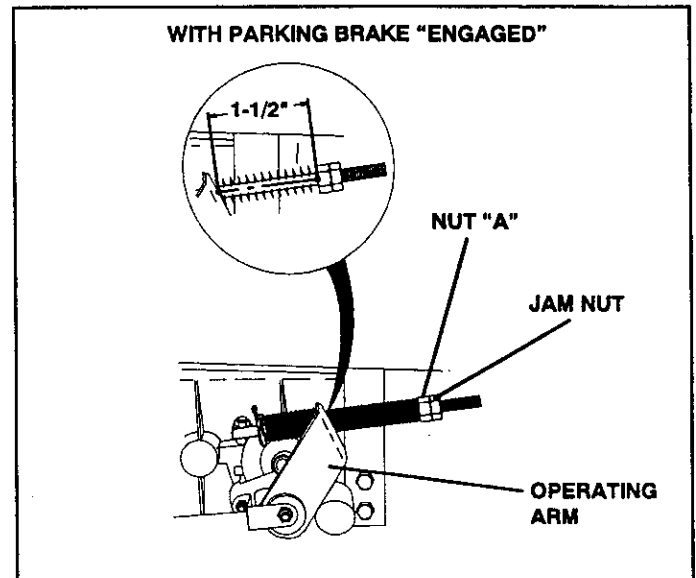

FIG. 25

TO REPLACE MOTION DRIVE BELT (See Fig. 26)

Park the tractor on level area. Engage parking brake. For assistance, there is a belt installation guide decal on bottom side of left footrest.

- Remove mower (See "TO REMOVE MOWER" in this section of this manual).
- Remove belt from stationary idler and clutching idler.
- Remove belt from engine pulley.
- Roll belt over top of transaxle pulley.
- Install new belt by reversing above procedure.

IMPORTANT: REPLACE ONLY WITH BELT LISTED IN THIS MANUAL.

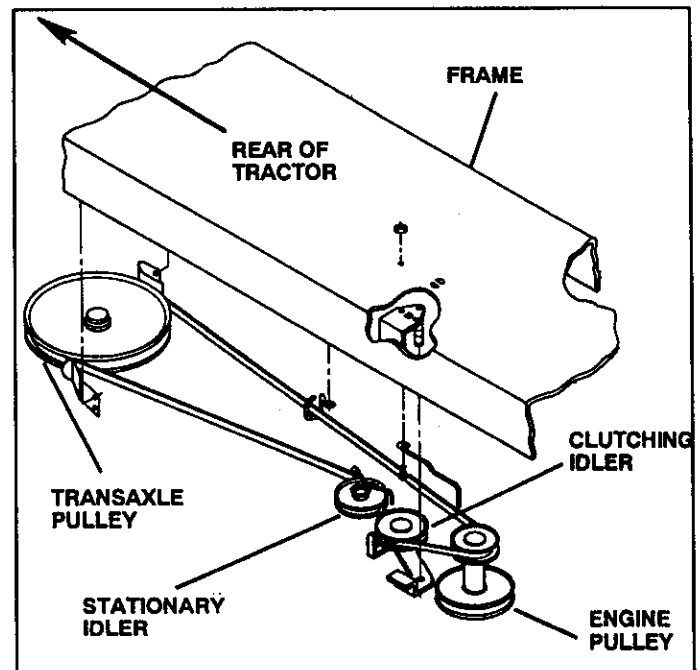

FIG. 26

SERVICE AND ADJUSTMENTS

TO ADJUST STEERING WHEEL ALIGNMENT

If steering wheel crossbars are not horizontal (left to right) when wheels are positioned straight forward, remove steering wheel and reassemble per instructions in the Assembly section of this manual.

FRONT WHEEL TOE-IN/CAMBER

The front wheel toe-in and camber are not adjustable on your unit. If damage has occurred to affect the front wheel toe-in or camber, contact your nearest Authorized Service Center.

TO REMOVE WHEEL FOR REPAIRS (See Fig. 27)

- Block up axle securely.
- Remove hub cap, retaining ring and washers to allow wheel removal (rear wheel contains a square key - Do not lose).
- Repair tire and reassemble.
- On rear wheels only: align grooves in rear wheel hub and axle. Insert square key.
- Replace washers and snap retaining ring securely in axle groove.
- Replace hub cap.

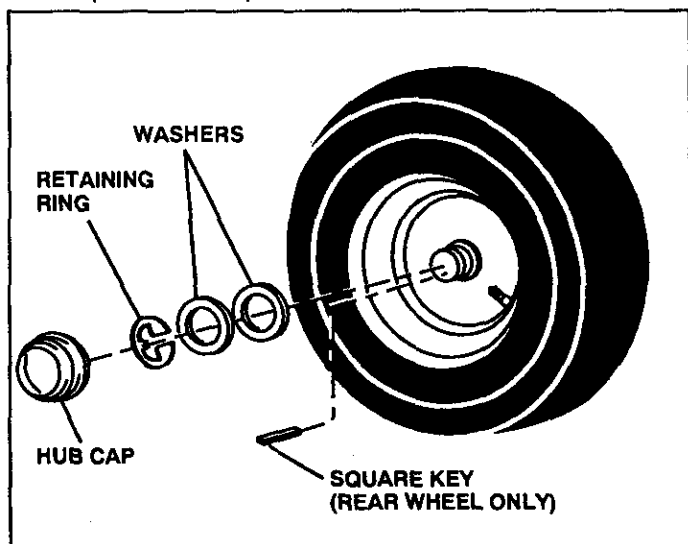

FIG. 27

TO START ENGINE WITH A WEAK BATTERY (See Figs. 28 & 29)



CAUTION: Lead-acid batteries generate explosive gases. Keep sparks, flame and smoking materials away from batteries. Always wear eye protection when around batteries.

If your battery is too weak to start the engine, it should be recharged. If "jumper cables" are used for emergency starting, follow this procedure:

IMPORTANT: YOUR UNIT IS EQUIPPED WITH A 12 VOLT NEGATIVE GROUND SYSTEM. THE OTHER VEHICLE MUST ALSO BE A 12 VOLT NEGATIVE GROUND SYSTEM. DO NOT USE YOUR TRACTOR BATTERY TO START OTHER VEHICLES.

TO ATTACH JUMPER CABLES -

- Connect each end of the RED cable to the POSITIVE (+) terminal of each battery, taking care not to short against chassis.
- Connect one end of the BLACK cable to the NEGATIVE (-) terminal of fully charged battery.
- Connect the other end of the BLACK cable to a panel bolt on the left side of the chassis, away from fuel tank and battery.

TO REMOVE CABLES, REVERSE ORDER -

- BLACK cable first from left side of chassis and fully charged battery.
- RED cable last from both batteries.

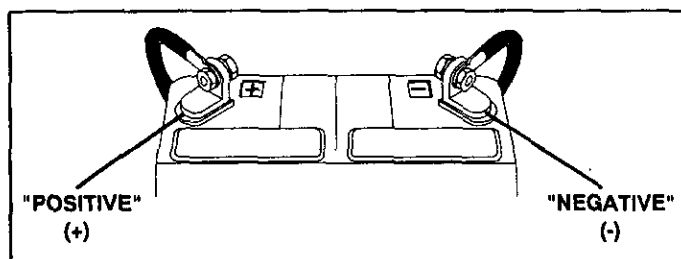

FIG. 28

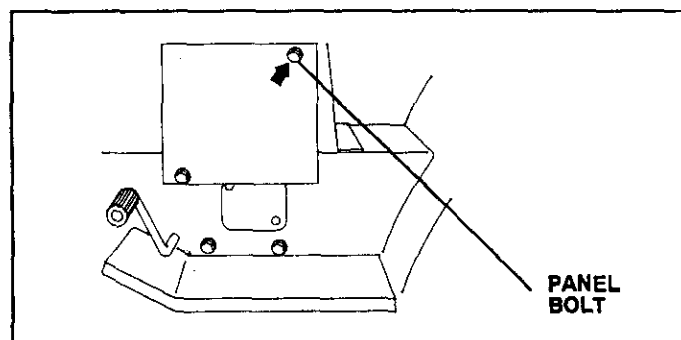

FIG. 29

TO REPLACE FUSE

Replace with 30 amp automotive-type plug-in fuse. The fuse holder is located under the dash, directly behind the engine.

TO REPLACE HEADLIGHT BULB

- Raise hood.
- Pull bulb holder out of the hole in the backside of the grill.
- Replace bulb in holder and push bulb holder securely back into the hole in the backside of the grill.
- Close hood.

SERVICE AND ADJUSTMENTS

ENGINE

TO ADJUST THROTTLE CONTROL CABLE (See Fig. 30)

The throttle control has been preset at the factory and adjustment should not be necessary. Check adjustment as described below before loosening cable. If adjustment is necessary, proceed as follows:

- With engine not running, move throttle control lever from "SLOW" to "CHOKE" position. Slowly move lever from "CHOKE" to "FAST" position.
- Check to see if hole in throttle lever and hole in speed control bracket are aligned.
- If holes are not aligned, loosen cable clamp screw and align the holes by inserting a pencil or a 1/4" drill bit through both holes.
- Pull throttle cable up to remove slack and tighten cable clamp screw. Remove alignment pencil or drill bit.

TO ADJUST CARBURETOR (See Fig. 31)

The carburetor has been preset at the factory and adjustment should not be necessary. However, minor adjustment may be required to compensate for differences in fuel, temperature, altitude or load. If the carburetor does need adjustment, proceed as follows:

In general, turning the adjusting needles in (clockwise) decreases the supply of fuel to the engine giving a leaner fuel/air mixture. Turning the adjusting needles out (counterclockwise) increases the supply of fuel to the engine giving a richer fuel/air mixture.

IMPORTANT: DAMAGE TO THE NEEDLES AND THE SEATS IN CARBURETOR MAY RESULT IF NEEDLE IS TURNED IN TOO TIGHT.

PRELIMINARY SETTING -

- Be sure you have a clean air filter and the throttle control cable is adjusted properly (see above).
- With engine off turn idle fuel adjusting needle in (clockwise) closing it finger tight and then turn out (counterclockwise) 1 turn.

FINAL SETTING -

- Start engine and allow to warm for five minutes. Make final adjustments with engine running and shift/motion control lever in "NEUTRAL" position.
- Idle speed setting - With throttle control lever in "SLOW" position, engine should idle at 1625 RPM. If engine idles too slow or fast, turn idle speed adjusting screw in or out until correct idle is attained.
- Idle fuel needle setting - With throttle control lever in "SLOW" position, turn idle fuel adjusting needle in (clockwise) until engine begins to die and then turn out (counterclockwise) approximately 1/8 to 1/4 turn to obtain best low speed performance.
- Recheck idle speed. Readjust if necessary.

ACCELERATION TEST -

- Move throttle control lever from "SLOW" to "FAST" position. If engine hesitates or dies, turn idle fuel adjusting needle out (counterclockwise) 1/8 turn. Repeat test and continue to adjust, if necessary, until engine accelerates smoothly.

High speed stop is factory adjusted. Do not adjust - damage may result.

IMPORTANT: NEVER TAMPER WITH THE ENGINE GOVERNOR, WHICH IS FACTORY SET FOR PROPER ENGINE SPEED. OVERSPEEDING THE ENGINE ABOVE THE FACTORY HIGH SPEED SETTING CAN BE DANGEROUS. IF YOU THINK THE ENGINE-GOVERNED HIGH SPEED NEEDS ADJUSTING, CONTACT YOUR NEAREST SEARS SERVICE CENTER, WHICH HAS PROPER EQUIPMENT AND EXPERIENCE TO MAKE ANY NECESSARY ADJUSTMENTS.

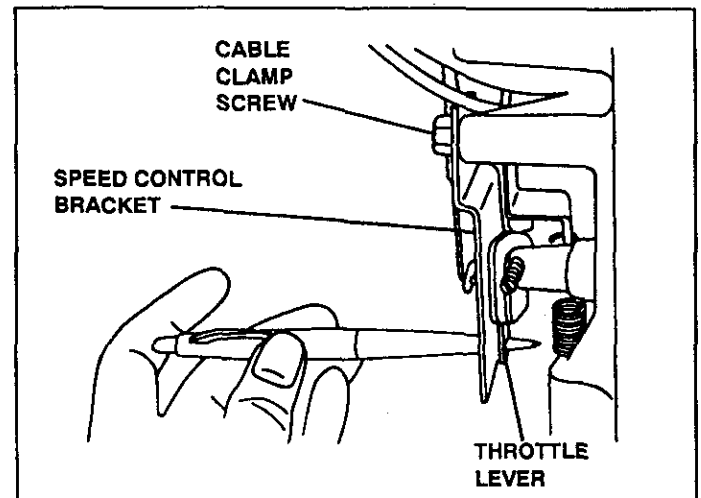

FIG. 30

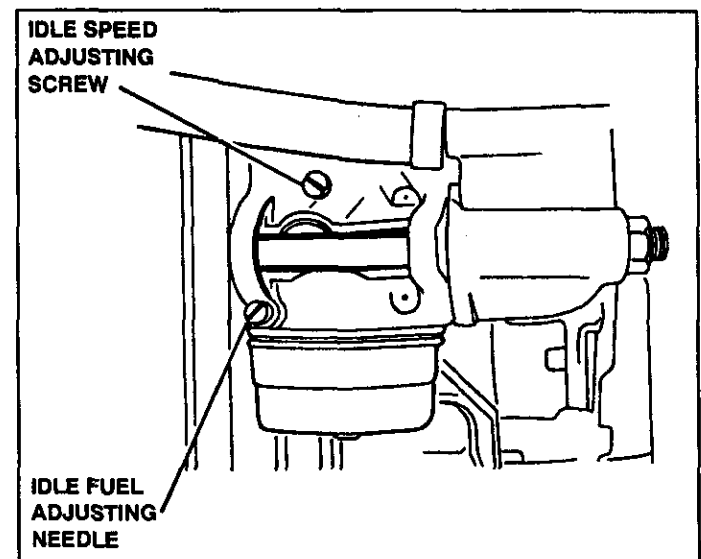

FIG. 31

STORAGE

Immediately prepare your tractor for storage at the end of the season or if the unit will not be used for 30 days or more.



CAUTION: Never store the tractor with gasoline in the tank inside a building where fumes may reach an open flame or spark. Allow the engine to cool before storing in any enclosure.

TRACTOR

Remove mower from tractor for winter storage. When mower is to be stored for a period of time, clean it thoroughly, remove all dirt, grease, leaves, etc. Store in a clean, dry area.

- Clean entire tractor (See "CLEANING" in the Customer Responsibilities section of this manual).
- Inspect and replace belts, if necessary (See belt replacement instructions in the Service and Adjustments section of this manual).
- Lubricate as shown in the Customer Responsibilities section of this manual.
- Be sure that all nuts, bolts and screws are securely fastened. Inspect moving parts for damage, breakage and wear. Replace if necessary.
- Touch up all rusted or chipped paint surfaces; sand lightly before painting.

BATTERY

- Fully charge the battery for storage.
- After a period of time in storage, battery may require recharging.
- To help prevent corrosion and power leakage during long periods of storage, battery cables should be disconnected and battery cleaned thoroughly (see "TO CLEAN BATTERY AND TERMINALS" in the Customer Responsibilities section of this manual).
- After cleaning, leave cables disconnected and place cables where they cannot come in contact with battery terminals.
- Be sure battery drain tube is securely attached.

ENGINE

FUEL SYSTEM

IMPORTANT: IT IS IMPORTANT TO PREVENT GUM DEPOSITS FROM FORMING IN ESSENTIAL FUEL SYSTEM PARTS SUCH AS CARBURETOR, FUEL FILTER, FUEL HOSE, OR TANK DURING STORAGE. ALSO, EXPERIENCE INDICATES THAT ALCOHOL BLENDED FUELS (CALLED GASOHOL OR USING ETHANOL OR METHANOL) CAN ATTRACT MOISTURE WHICH LEADS TO SEPARATION AND FORMATION OF ACIDS DURING STORAGE. ACIDIC GAS CAN DAMAGE THE FUEL SYSTEM OF AN ENGINE WHILE IN STORAGE.

- Drain the fuel tank.
- Start the engine and let it run until the fuel lines and carburetor are empty.
- Never use engine or carburetor cleaner products in the fuel tank or permanent damage may occur.
- Use fresh fuel next season.

NOTE: Fuel stabilizer is an acceptable alternative in minimizing the formation of fuel gum deposits during storage. Add stabilizer to gasoline in fuel tank or storage container. Always follow the mix ratio found on stabilizer container. Run engine at least 10 minutes after adding stabilizer to allow the stabilizer to reach the carburetor. Do not drain the gas tank and carburetor if using fuel stabilizer.

ENGINE OIL

Drain oil (with engine warm) and replace with clean engine oil. (See "ENGINE" in the Customer Responsibilities section of this manual).

CYLINDERS

- Remove spark plug(s).
- Pour one ounce of oil through spark plug hole(s) into cylinder(s).
- Turn ignition key to "START" position for a few seconds to distribute oil.
- Replace with new spark plug(s).

OTHER

- Do not store gasoline from one season to another.
- Replace your gasoline can if your can starts to rust. Rust and/or dirt in your gasoline will cause problems.
- If possible, store your unit indoors and cover it to give protection from dust and dirt.
- Cover your unit with a suitable protective cover that does not retain moisture. Do not use plastic. Plastic cannot breathe which allows condensation to form and will cause your unit to rust.

IMPORTANT: NEVER COVER TRACTOR WHILE ENGINE AND EXHAUST AREAS ARE STILL WARM.

TROUBLESHOOTING POINTS

PROBLEM	CAUSE	CORRECTION
Will not start	<ol style="list-style-type: none"> 1. Out of fuel. 2. Engine not "CHOKED" properly. 3. Engine flooded. 4. Bad spark plug. 5. Dirty air filter. 6. Dirty fuel filter. 7. Water in fuel. 8. Loose or damaged wiring. 9. Carburetor out of adjustment. 10. Engine valves out of adjustment. 	<ol style="list-style-type: none"> 1. Fill fuel tank. 2. See TO START ENGINE in Operation section. 3. Wait several minutes before attempting to start. 4. Replace spark plug. 5. Clean/replace air filter. 6. Replace fuel filter. 7. Drain fuel tank and carburetor, refill tank with fresh gasoline and replace fuel filter. 8. Check all wiring. 9. Contact Sears Service Department. 10. Contact Sears Service Department.
Hard to start	<ol style="list-style-type: none"> 1. Dirty air filter. 2. Bad spark plug. 3. Weak or dead battery. 4. Dirty fuel filter. 5. Stale or dirty fuel. 6. Loose or damaged wiring. 7. Carburetor out of adjustment. 8. Engine valves out of adjustment. 	<ol style="list-style-type: none"> 1. Clean/replace air filter. 2. Replace spark plug. 3. Recharge or replace battery. 4. Replace fuel filter. 5. Drain fuel tank and refill with fresh gasoline. 6. Check all wiring. 7. Contact Sears Service Department. 8. Contact Sears Service Department.
Engine will not turn over	<ol style="list-style-type: none"> 1. Clutch/brake pedal not depressed. 2. Attachment clutch is engaged. 3. Spark plug wire is disconnected. 4. Weak or dead battery. 5. Blown fuse. 6. Corroded battery terminals. 7. Loose or damaged wiring. 8. Faulty ignition switch. 9. Faulty solenoid or starter. 10. Faulty operator presence switch(es). 	<ol style="list-style-type: none"> 1. Depress clutch/brake pedal. 2. Disengage attachment clutch. 3. Connect wire to spark plug. 4. Recharge or replace battery. 5. Replace fuse. 6. Clean battery terminals. 7. Check all wiring. 8. Check/replace ignition switch. 9. Check/replace solenoid or starter. 10. Contact Sears Service Department.
Engine clicks but will not start	<ol style="list-style-type: none"> 1. Weak or dead battery. 2. Corroded battery terminals. 3. Loose or damaged wiring. 4. Faulty solenoid or starter. 	<ol style="list-style-type: none"> 1. Recharge or replace battery. 2. Clean battery terminals. 3. Check all wiring. 4. Check/replace solenoid or starter.
Loss of power	<ol style="list-style-type: none"> 1. Cutting too much grass/too fast. 2. Throttle in "CHOKE" position. 3. Build-up of grass, leaves and trash under mower. 4. Dirty air filter. 5. Low oil level/dirty oil. 6. Faulty spark plug. 7. Dirty fuel filter. 8. Stale or dirty fuel. 9. Water in fuel. 10. Spark plug wire loose. 11. Dirty engine air screen/fins. 12. Dirty/clogged muffler. 13. Loose or damaged wiring. 14. Carburetor out of adjustment. 15. Engine valves out of adjustment. 	<ol style="list-style-type: none"> 1. Set in "Higher Cut" position/reduce speed. 2. Adjust throttle control. 3. Clean underside of mower housing. 4. Clean/replace air filter. 5. Check oil level/change oil. 6. Clean and regap or change spark plug. 7. Replace fuel filter. 8. Drain fuel tank and refill with fresh gasoline. 9. Drain fuel tank and carburetor, refill tank with fresh gasoline and replace fuel filter. 10. Connect and tighten spark plug wire. 11. Clean engine air screen/fins. 12. Clean/replace muffler. 13. Check all wiring. 14. Contact Sears Service Department. 15. Contact Sears Service Department.
Excessive vibration	<ol style="list-style-type: none"> 1. Worn, bent or loose blade. 2. Bent blade mandrel. 3. Loose/damaged part(s). 	<ol style="list-style-type: none"> 1. Replace blade. Tighten blade bolt. 2. Replace blade mandrel. 3. Tighten loose part(s). Replace damaged parts.

TROUBLESHOOTING POINTS

PROBLEM	CAUSE	CORRECTION
Engine continues to run when operator leaves seat with attachment clutch engaged	<ol style="list-style-type: none"> 1. Faulty operator-safety presence control system. 	<ol style="list-style-type: none"> 1. Check wiring, switches and connections. If not corrected, contact Sears Service Department.
Poor cut - uneven	<ol style="list-style-type: none"> 1. Worn, bent or loose blade. 2. Mower deck not level. 3. Buildup of grass, leaves, and trash under mower. 4. Bent blade mandrel. 	<ol style="list-style-type: none"> 1. Replace blade. Tighten blade bolt. 2. Level mower deck. 3. Clean underside of mower housing. 4. Replace blade mandrel.
Mower blades will not rotate	<ol style="list-style-type: none"> 1. Obstruction in clutch mechanism. 2. Worn/damaged mower drive belt. 3. Frozen idler pulley. 4. Frozen blade mandrel. 	<ol style="list-style-type: none"> 1. Remove obstruction. 2. Replace mower drive belt. 3. Replace idler pulley. 4. Replace blade mandrel.
Poor grass discharge	<ol style="list-style-type: none"> 1. Engine speed too slow. 2. Travel speed too fast. 3. Wet grass. 4. Mower deck not level. 5. Low/uneven tire air pressure. 6. Worn, bent or loose blade. 7. Buildup of grass, leaves and trash under mower. 8. Mower drive belt worn. 9. Blades improperly installed. 10. Improper blades used. 	<ol style="list-style-type: none"> 1. Place throttle control in "FAST" position. 2. Shift to slower speed. 3. Allow grass to dry before mowing. 4. Level mower deck. 5. Check tires for proper air pressure. 6. Replace/sharpen blade. Tighten blade bolt. 7. Clean underside of mower housing. 8. Replace mower drive belt. 9. Reinstall blades sharp edge down. 10. Replace with blades listed in this manual.
Headlight(s) not working (if so equipped)	<ol style="list-style-type: none"> 1. Switch is "OFF". 2. Bulb(s) burned out. 3. Faulty light switch. 4. Loose or damaged wiring. 5. Blown fuse. 	<ol style="list-style-type: none"> 1. Turn switch "ON". 2. Replace bulb(s). 3. Check/replace light switch. 4. Check wiring and connections. 5. Replace fuse.
Battery will not charge	<ol style="list-style-type: none"> 1. Bad battery cell(s). 2. Poor cable connections. 3. Faulty regulator (if so equipped). 4. Faulty alternator. 	<ol style="list-style-type: none"> 1. Replace battery. 2. Check/clean all connections. 3. Replace regulator. 4. Replace alternator.

14 HP 42" RIDING LAWN TRACTOR - - MODEL NUMBER 917.255690

SCHEMATIC

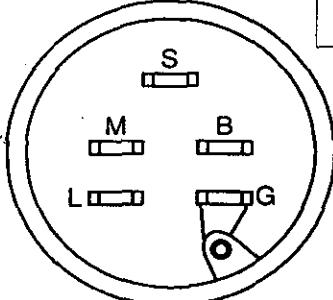
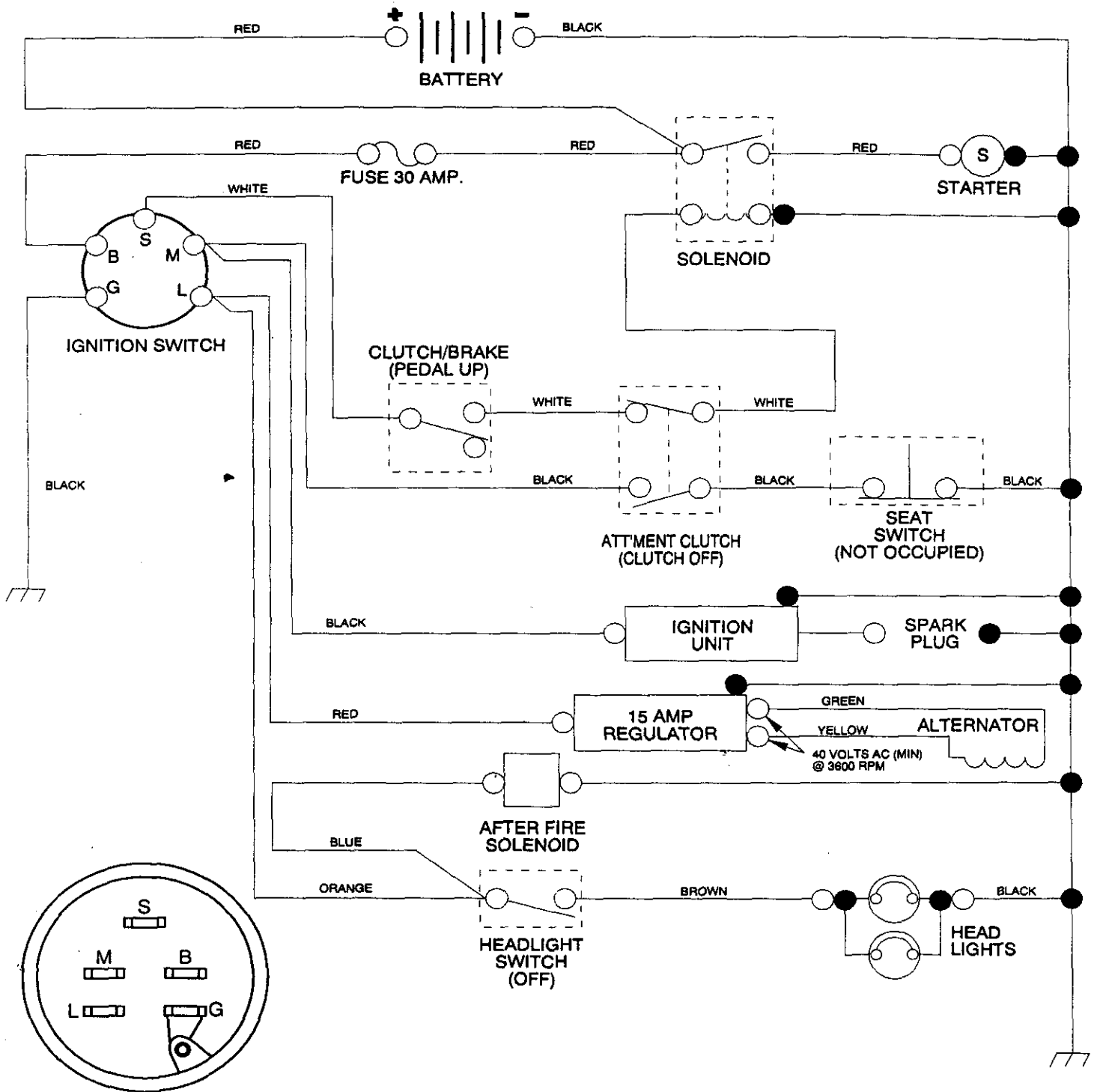

IGNITION SWITCH

POSITION	CIRCUIT
OFF	M + G
ON	B + L
START	B + S + L

- NON-REMOVABLE CONNECTIONS
- REMOVABLE CONNECTIONS

WIRING INSULATED CLIPS
 NOTE: IF WIRING INSULATED CLIPS WERE REMOVED FOR SERVICING OF UNIT, THEY SHOULD BE REPLACED TO PROPERLY SECURE YOUR WIRING

SERVICE NOTES

REPAIR PARTS

14 HP 42" RIDING LAWN TRACTOR - - MODEL NUMBER 917.255690

ELECTRICAL

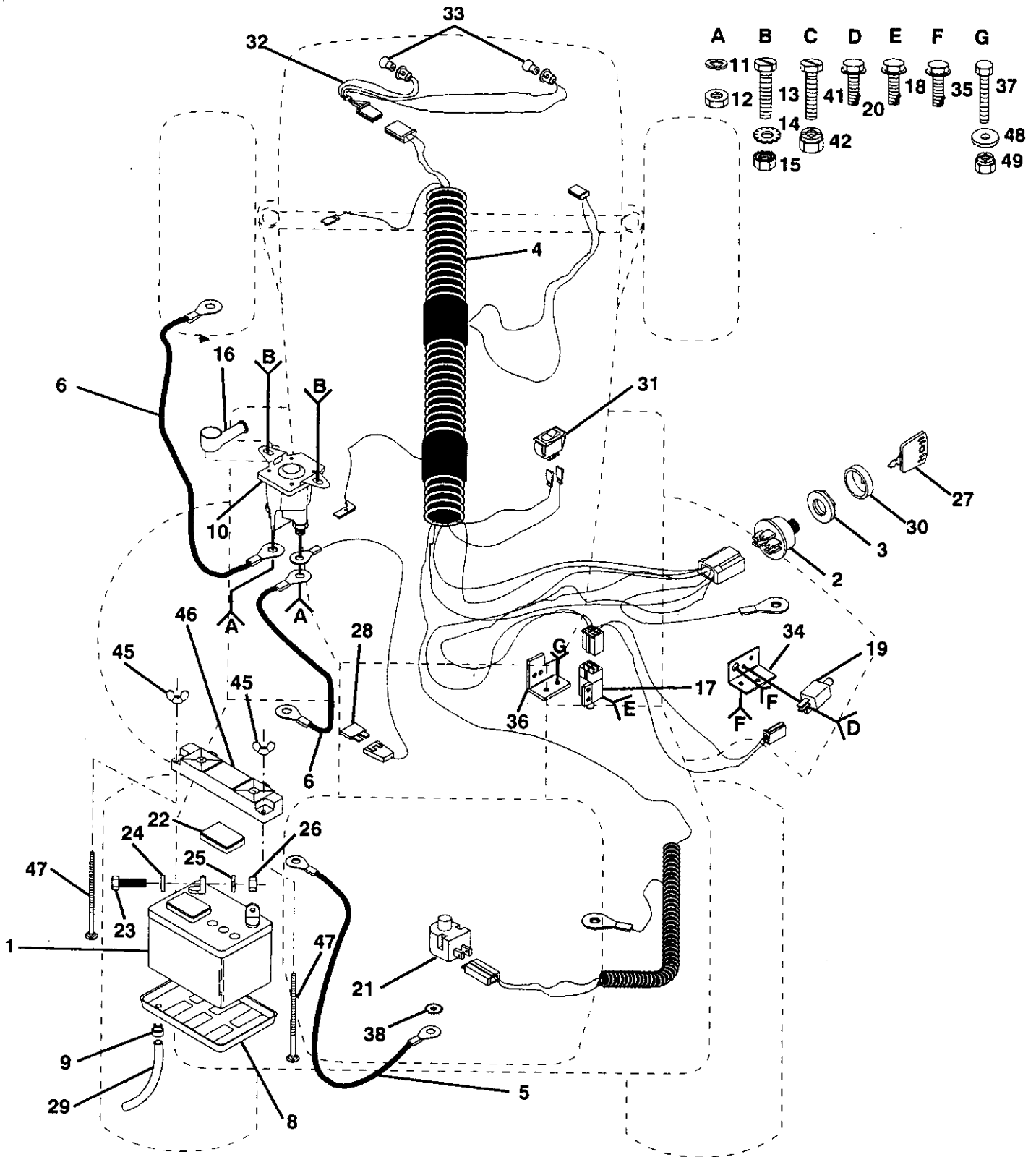

REPAIR PARTS

14 HP 42" RIDING LAWN TRACTOR - - MODEL NUMBER 917.255690

ELECTRICAL

KEY NO.	PART NO.	DESCRIPTION
1	121537X	Battery 12 Volt 30 Amp
2	102972X	Switch Ignition 5 Term
3	124211X	Nut Ignition
4	133135	Harness Ign Koh Dash HI
5	4207J	Cable Ground 6ga 12"black
6	4206J	Cable Battery 6ga 22" Red
8	7603J	Tray Battery 7 80 x 5 25 Blk
9	109596X	Clamp Hose Olive
10	109081X	Solenoid
11	STD551125	Lockwasher
12	73350400	Nut Jam Hex 1/4-20 Unc
13	74780408	Bolt Fin Hex 1/4-20uncx1/2 Gr5
14	STD551225	Washer
15	STD541425	Nut
16	131563	Cover Terminal Red
17	109553X	Switch Intlk Clutch Red 4 Term
18	STD601005	Screw
19	104445X	Switch Intlk Clutch Red 2 Term
20	STD601005	Screw
21	121305X	Switch Plunger Nc Gray
22	121264X	Caps Battery 20/25/30 Amp
23	74760412	Bolt Hex Hd 1/4-20unc x 3/4
24	STD551025	Washer
25	STD551125	Washer
26	STD541025	Nut
27	109310X	Key Ign Molded Craftsman
28	108824X	Fuse 30 Amp Auto Green
29	100541K	Tube Plastic 31"
30	123620X	Cover Sw Key Blk 1 25 Text Slit
31	110712X	Switch Light Blk Blk Red
32	127441X	Harness Socket Light
33	4152J	Bulb Light #1156
34	108236X	Bracket Switch Clutch
35	STD601005	Screw
36	110923X	Bracket Mower Clutch
37	74760616	Bolt Hex 3/8-16 x 1
38	STD551237	Washer
45	123198X	Nut Plastic Locking Wng 1/4-20
46	102476X	Guard Terminal Blk
47	STD532575	Bolt
48	19131312	Washer 13/32 x 13/16 x 12 Ga
49	STD541437	Nut

NOTE: All component dimensions given in U.S. inches
1 inch = 25.4 mm

REPAIR PARTS

14 HP 42" RIDING LAWN TRACTOR - - MODEL NUMBER 917.255690

CHASSIS AND ENCLOSURES

KEY NO.	PART NO.	DESCRIPTION	KEY NO.	PART NO.	DESCRIPTION
1	131052	Chassis Widmt 12ga 38/42 Hpvts	67	106004X	Lens Headlight Lh Clear
2	130805	Drawbar 12 Ga 46 5"wheel Base	68	132257	Bezel Light
3	17490612	Screw Thdrol 3/8-16x3/4 Ty-tt	70	108512X	Bracket Asm Pivot Rh
6	123783X012	Saddle Silkscreened	71	108513X	Bracket Asm Pivot Lh
7	17490608	Screw Thdrol 3/8-16x1/2 Ty-tt	76	110350X459	Strap Asm Pnt Grille
8	2751R	Clip Line Fuel 13/32 Mtg Hole	88	106090X	Hinge Asm Lh
9	120028X	Dash Black Plastic	89	108067X	Nut Pal # W142068b02
10	5479J	Plug Button Blk 359 Dia	90	105531X	Nut Push Nylon
11	124118X	Panel Dash Lh	91	17490612	Screw Thdrol 3/8-16x3/4 Ty-tt
12	121794X	Cover Access Black Square	92	123934X	Scale Ind Height Blk
13	133748	Panel Dash Rh	93	19112410	Washer 11/32 x 1-1/2 10 Ga
14	17490612	Screw Thdrol 3/8-16x3/4 Ty-tt	94	STD551131	Lockwasher
18	129621X012	Plate Silkscreened Dash	95	74780516	Bolt Fin Hex 5/16-18unc x 1 00
19	74180412	Screw Mach Cr 1/4-20 3/4	97	123935X	Plug Hole Blk 1 485/1 515 Dia
20	STD551025	Washer 17/64	98	120579X	Nut Pal
21	STD541425	Nut	99	5320R	Clip Insulated 1/4 Clpg Dia
22	74180512	Screw Mach Trhd 5/16-18uncx3/4	100	120529X	Washer Nylon 44 x 75 x 032
23	73680500	Nut Crownlock 5/16-18	101	123933X394	Pointer Pnt Height Indicator
24	STD523707	Bolt	102	108067X	Nut Pal
25	19131312	Washer 13/32 x 13/16 x 12 Ga	103	128231	Plate Support Battery
26	STD541437	Nut	104	STD523707	Bolt
27	105509X	Bracket Asm Fender 7 250	105	106909X	Screw Special Dacrotized
28	105528X	Grille Welded	106	106910X	Washer Alum
30	123784X459	Fender Pnt Yt/gt Dover	107	108402X	Clip U Alum
33	105465X459	Footrest Pnt Lh	108	17490612	Screw Thdrol 3/8-16x3/4 Ty-tt
34	105464X459	Footrest Pnt Rh (dover Gray)	109	110436X	Bushing Snap Split Blk
35	STD533707	Bolt	110	STD551137	Lockwasher
36	STD541437	Nut	111	STD541037	Nut
37	105466X	Pad Footrest Rbr Sq Craftsman	112	STD533727	Bolt
38	2751R	Clip Line Fuel 13/32 Mtg Hole	113	19131416	Washer 13/32 x 7/8 x 16ga
39	STD551237	Washer	114	121235X	Spacer Split
40	STD541437	Nut	115	105525X	Bracket Support Dash
41	121235X	Spacer Split 391x1 88 Blk/zin	116	STD523707	Bolt
44	STD523707	Bolt	117	73680600	Nut Crownlock
45	STD541437	Nut	118	STD523120	Bolt Hex 5/16-18 x 2
46	105518X	Dash Lower	119	STD541431	Nut Crownlock 5/16-18
47	17490608	Screw Thdrol 3/8-16x1/2 Ty-tt	120	2751R	Clip Line Fuel 13/32 Mtg Hole
48	109015X	Bracket Asm Fr Pvt Hng Lh Sear	121	STD533710	Bolt
49	109016X	Bracket Asm Fr Pvt Hng Rh Sear			
50	106013X459	Hood Asm Pnt Dover Gray Powder			
51	106091X	Hinge Asm Rh			
54	108067X	Nut Pal # W142068b02			
61	108403X459	Panel Asm Pnt Side Rh			
62	108410X459	Panel Pnt Side Lh			
66	106003X	Lens Headlight Rh Clear			

NOTE: All component dimensions given in U.S. inches
1 inch = 25.4 mm

REPAIR PARTS

14 HP 42" RIDING LAWN TRACTOR -- MODEL NUMBER 917.255690

DRIVE

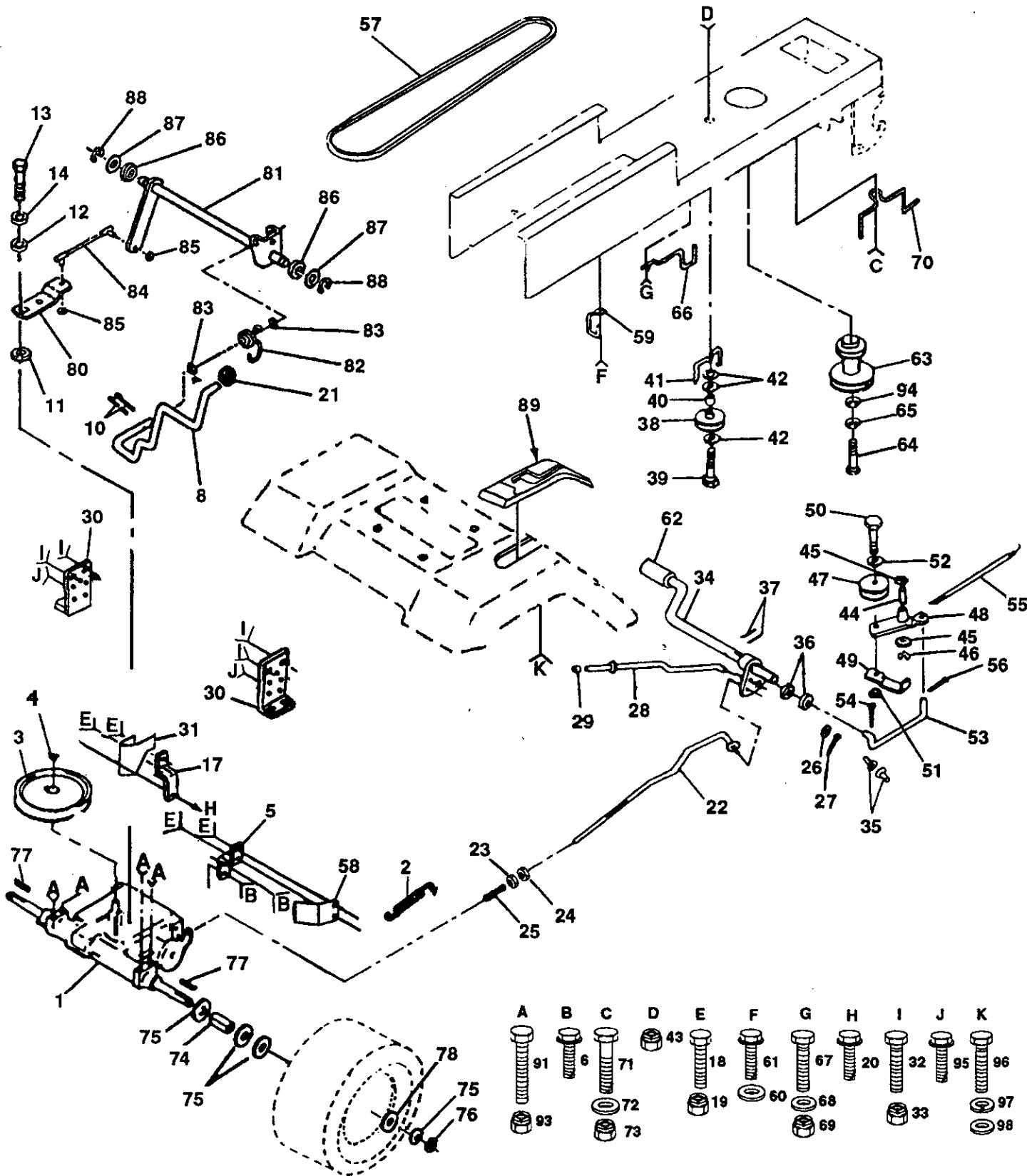

REPAIR PARTS

14 HP 42" RIDING LAWN TRACTOR - - MODEL NUMBER 917.255690

DRIVE

KEY NO.	PART NO.	DESCRIPTION	KEY NO.	PART NO.	DESCRIPTION
1	131965	Transaxle 6 Sp Medium Dana	54	STD561210	Pin
2	110422X	Spring Return Brake T/a Zinc	55	105709X	Spring Return Clutch 6 75
3	123667X	Pulley Transaxle 20"tires	56	STD561210	Pin
4	12000028	Ring Retainer # 5100-62	57	131006	V-belt Gnd Dr 98 25 Yt Stretch
5	121520X	Strap Torque 30 Degrees	58	127290	Keeper Belt Rh Yt Pnt/zinc 16g
6	17490512	Screw Thdrol 5/16-18 x 3/4 Tyt	59	104777X	Retainer Belt Chassis Lh Zinc
8	127288X	Rod Shifter Fender Yt 14 325lg	60	19131312	Washer 13/32 x 13/16 x 12 Ga
10	STD561210	Pin	61	17490612	Screw Thdrol 3/8-16x3/4 Ty-tt
11	105701X	Washer Plate Shf 388 Sq Hole	62	8883R	Cover Pedal Blk Round
12	19151216	Washer 15/32 x 3/4 x 16ga	63	131002	Pulley Engine
13	71040412	Bolt Fin Hex 1/4-28unfx3/4 Gr8	64	M010110110	Bolt Hex M10-1 5x110
14	STD551125	Washer Lock Hvy Helical	65	STD551143	Washer
17	121520X	Strap Torque 30 Degrees	66	129921	Keeper Belt Engine Lh Lt
18	STD523707	Bolt	67	STD523710	Bolt
19	STD541437	Nut	68	19131312	Washer 13/32 x 13/16 x 12 Ga
20	17490512	Screw Thdrol 5/16-18 x 3/4 Tyt	69	STD541437	Nut
21	106933X	Knob Rd 1/2-13 Plstc Thds Blk	70	131402	Guide Belt Dr Mower Rh
22	130804	Rod Brake Blk Zinc 26 840	71	STD523710	Bolt
23	STD541437	Locknut	72	19132012	Washer 13/32 x 1-1/4 x 12 Ga
24	STD541237	Nut	73	STD541437	Nut
25	106888X	Spring Rod Brake 2 00 Zinc	74	109502X	Spacer Split 80x1 94 Cad/zinc
26	STD551037	Washer	75	121749X	Washer 25/32 x 1 1/4 x 16 Ga
27	STD561210	Pin	76	STD581075	E Ring
28	133261	Rod Brake Parking 14 500	77	123583X	Key Square 2 0 x 1845/ 1865
29	124236X	Cap Parking Brake Red	78	121748X	Washer 25/32 x 1 5/8 x 16ga
30	130807	Bracket Mtg Transaxle	80	131487	Arm Shift Transaxle
31	127289	Keeper Belt Lh Yt 14 Ga	81	131811	Shaft Asm Shifter
32	STD523107	Bolt	82	123782X	Spring Torsion T/a
33	STD541431	Nut	83	19171216	Washer 17/32 x 3/4 x 16ga
34	122424X	Shaft Asm Pedal Foot 1 930	84	132183	Rod Tie Shf Adj Ball Jt 4 650
35	120183X	Bearing Nylon Blk 629 Id	85	73530400	Nut Nylock 1/4-28
36	STD551062	Washer	85	73530400	Nut Nylock 1/4-28
37	STD571810	Roll Pin	86	127272X	Bushing Pivot W/ 180 Step Pm
38	123674X	Pulley Idler Flat	87	126591X	Washer Shim 53 x 1 25 x 0598
39	STD523727	Bolt	88	STD581050	E Ring
40	4470J	Spacer Split 395 x 59 Bzp	89	127287X	Console Shift 6sp Wo/ign Yt Da
41	109070X	Keeper Belt Retainer	91	74760540	Bolt Fin Hex 5/16-18uncx 2-1/2
42	19131312	Washer 13/32 x 13/16 x 12 Ga	93	STD541431	Nut
43	STD541437	Nut	94	126197X	Washer 1-1/2 Odx15/32 Idx 250
44	105706X	Bearing Nyl 503 x 628 x 1 25	95	17490612	Screw Thdrol 3/8-16x3/4 Ty-tt
45	110812X	Washer Hardened	96	74640808	Screw #8x1/2
46	12000039	Ring Klip #t5304-50	97	10100800	Washer Lock #8
47	127783	Pulley Idler V Groove Plastic	98	19060718	Washer 3/16 x 7/16 x 18 Ga
48	123789X	Bellcrank Asm			
49	123205X	Retainer Belt Style Spring			
50	STD523715	Bolt			
51	STD541437	Nut			
52	STD551037	Washer			
53	105710X	Link Clutch 7 66			

NOTE: All component dimensions given in U.S. inches
1 inch = 25.4 mm

REPAIR PARTS

14 HP 42" RIDING LAWN TRACTOR - - MODEL NUMBER 917.255690

STEERING ASSEMBLY

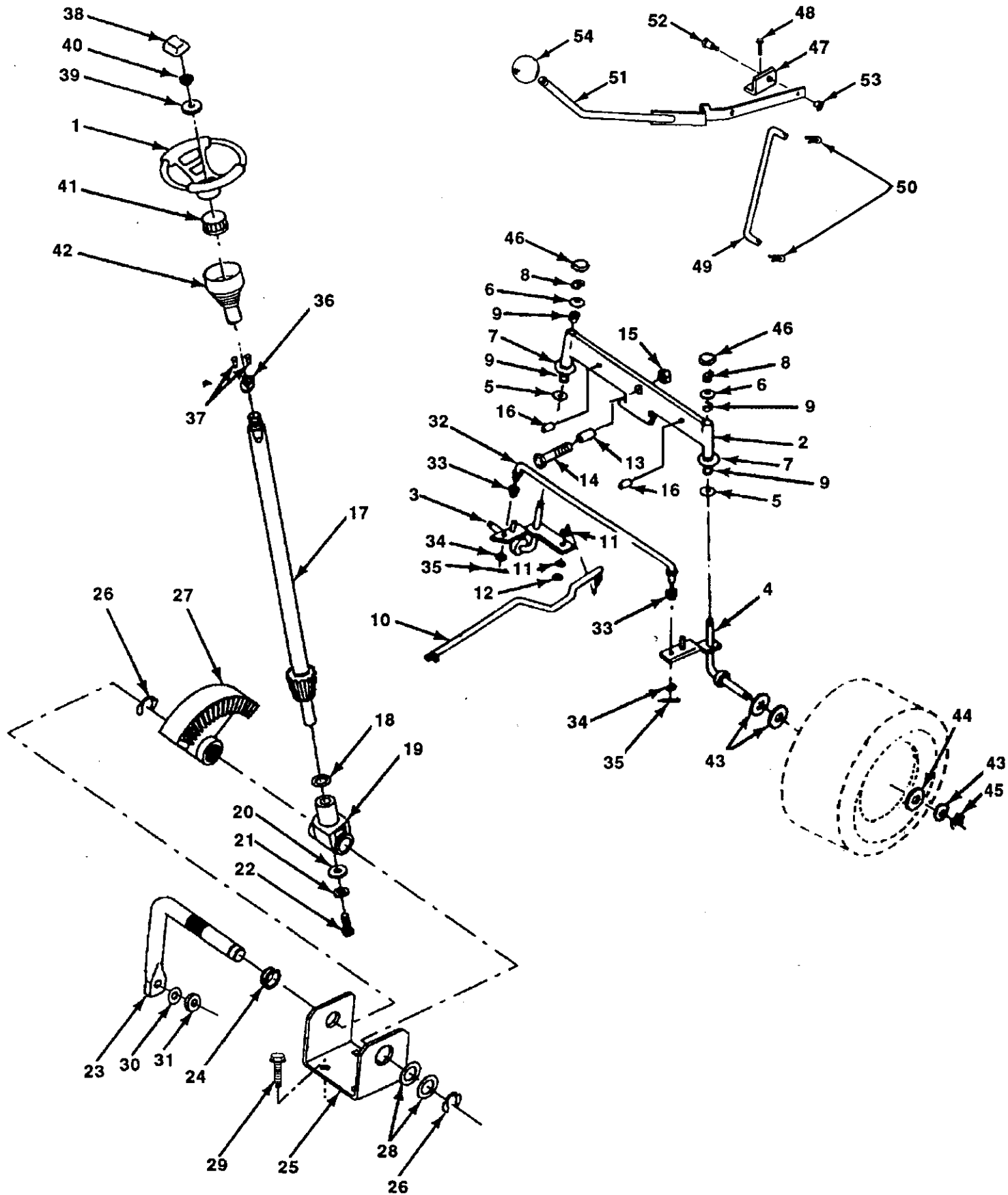

REPAIR PARTS

14 HP 42" RIDING LAWN TRACTOR - - MODEL NUMBER 917.255690

STEERING ASSEMBLY

KEY NO.	PART NO.	DESCRIPTION
1	100713N	Wheel Steering Ayp Black
2	131450	Axle Asm Front Lt 38/42
3	130460	Spindle Asm Lh
4	130459	Spindle Asm Rh
5	6266H	Bearing Race Thrust Harden
6	121748X	Washer 25/32 x 1 5/8 x 16ga
7	19272016	Washer 27/32 x 1 1/4 x 16 Ga
8	12000029	Ring Klip #t5304-75
9	3366R	Bearing Col Strg Blk
10	130468	Link Drag Sol Ball Jt 20 064
11	STD551137	Lockwasher
12	73610600	Nut Fin Hex 3/8-24 Unf
13	110438X	Spacer Bearing Axle Front
14	74011056	Bolt Hex 5/8-11 Unc x 3-1/2
15	73601000	Nut Hex Jam Lk W/wh 5/8-11 Unc
16	132624	Pin Axle 5/8 x 1 55/1 54 Lg
17	128755	Shaft Asm Strg 17 69 x 3/4 Yt
18	57079	Washer Thrust 515x 750x 033
19	124035X	Support Shaft
20	126684X	Washer Shim 1/4 x 5/8 x 062
21	STD551125	Washer
22	71070410	Screw Hex Socket 1/4-20 x 5/8
23	127501	Shaft Asm Pittman
24	109816X	Nyliner Snap In
25	124036X	Bracket Steering
26	12000029	Ring Klip #t5304-75
27	124034X	Gear Sector
28	6266H	Bearing Race Thrust Harden
29	17490612	Screw Thdrol 3/8-16x3/4 Ty-tt
30	STD551137	Lockwasher
31	73610600	Nut Fin Hex 3/8-24 Unf
32	130465	Rod Tie Wire Form 19 75 Mech
33	120754X	Bushing Rod Tie Blk Lt
34	19131416	Washer 13/32 x 7/8 x 16ga
35	STD561210	Pin
36	1554J	Bushing Strg Blk 742/747 Id
37	STD523710	Bolt
38	100710L	Insert Cap Strg Wheel Std Blk
39	100712K	Washer 53 x 2 25 x 160 Zinc
40	STD541350	Nut
41	100711L	Adapter Wheel Strg 758/ 753id
42	110709X	Column Steering
43	121749X	Washer 25/32 x 1 1/4 x 16 Ga
44	121748X	Washer 25/32 x 1 5/8 x 16ga
45	12000029	Ring Klip #t5304-75
46	121232X	Cap Spindle Fr Top Blk
47	131672	Bracket Pvt Man Cl Lvr V2 Sear
48	17490612	Screw Thdrol 3/8-16x3/4 Ty-tt
49	131291	Link Clutch W/nibs 5 688 Zinc
50	STD561210	Pin
51	125916X	Lever Assembly Clutch Mower
52	106451X	Bolt Shoulder 3/8-16 Unc Gr 2
53	STD541437	Nut
54	106933X	Knob Rd 1/2-13 Plstc Thds Blk

NOTE: All component dimensions given in U.S. inches
1 inch = 25.4 mm

REPAIR PARTS

14 HP 42" RIDING LAWN TRACTOR - - MODEL NUMBER 917.255690

SEAT ASSEMBLY

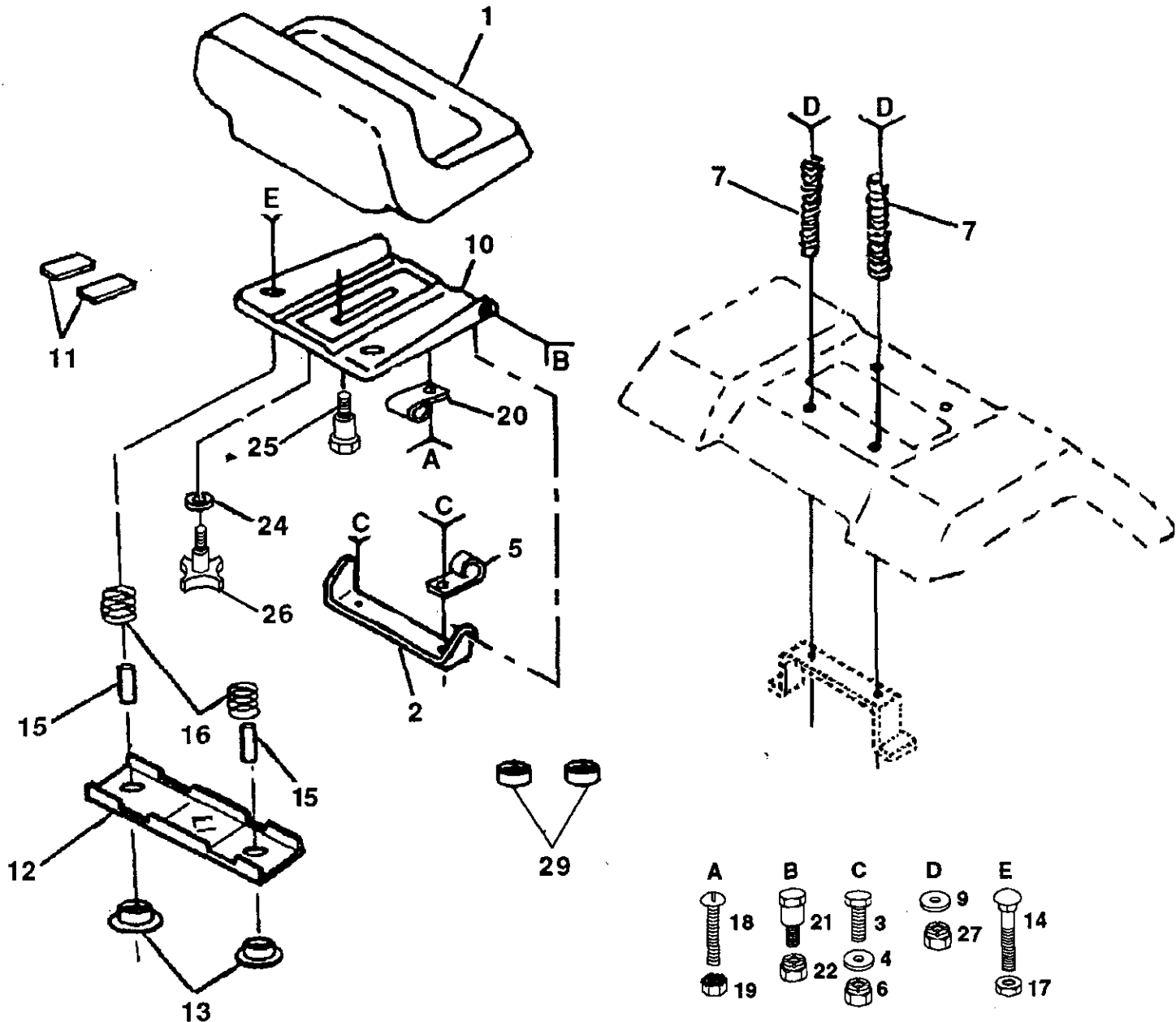

KEY NO.	PART NO.	DESCRIPTION
1	127438X	Seat V-450 Blk/red Craftsman
2	126656X	Bracket Pivot Seat 8 720
3	STD523707	Bolt
4	19131210	Washer 13/32 x 3/4 x 10 Ga
5	2751R	Clip Line Fuel 13/32 Mtg Hole
6	STD541437	Nut
7	124181X	Spring Seat Cprsn 2 250 Blk Zi
9	19131614	Washer 13/32 x 1 x 14 Ga
10	131451	Pan Seat
11	121251X	Strip Foam Gray Or Black
12	121246X	Bracket Mounting Switch
13	121248X	Bushing Snap Blk Nyl 50 Id
14	72050411	Bolt Rdhd Sht Nk 1/4-20x1-3/8
15	121249X	Spacer Split 28 x 88 Zinc

KEY NO.	PART NO.	DESCRIPTION
16	121250X	Spring Cprsn 1 27 Blk Pnt
17	123976X	Nut Lock 1/4 Lge Flg Gr 5 Zinc
18	STD511005	Screw
19	73951000	Nut Keps #10-32 Unf
20	4171R	Clip Insulated 11/32 Mtg Hole
21	105529X	Bolt Shoulder 5/16-18 Unc Blkz
22	STD541431	Nut
24	19171912	Washer 17/32 x 1-3/16 x 12 Ga
25	127018X	Bolt Shoulder 5/16-18 x 62
26	120068X	Knob Seat 1/2-13unc Blk
27	STD541437	Nut
29	124238X	Cap Spring Seat Blk 1 75 x 1 0

REPAIR PARTS

14 HP 42" RIDING LAWN TRACTOR -- MODEL NUMBER 917.255690

DECALS

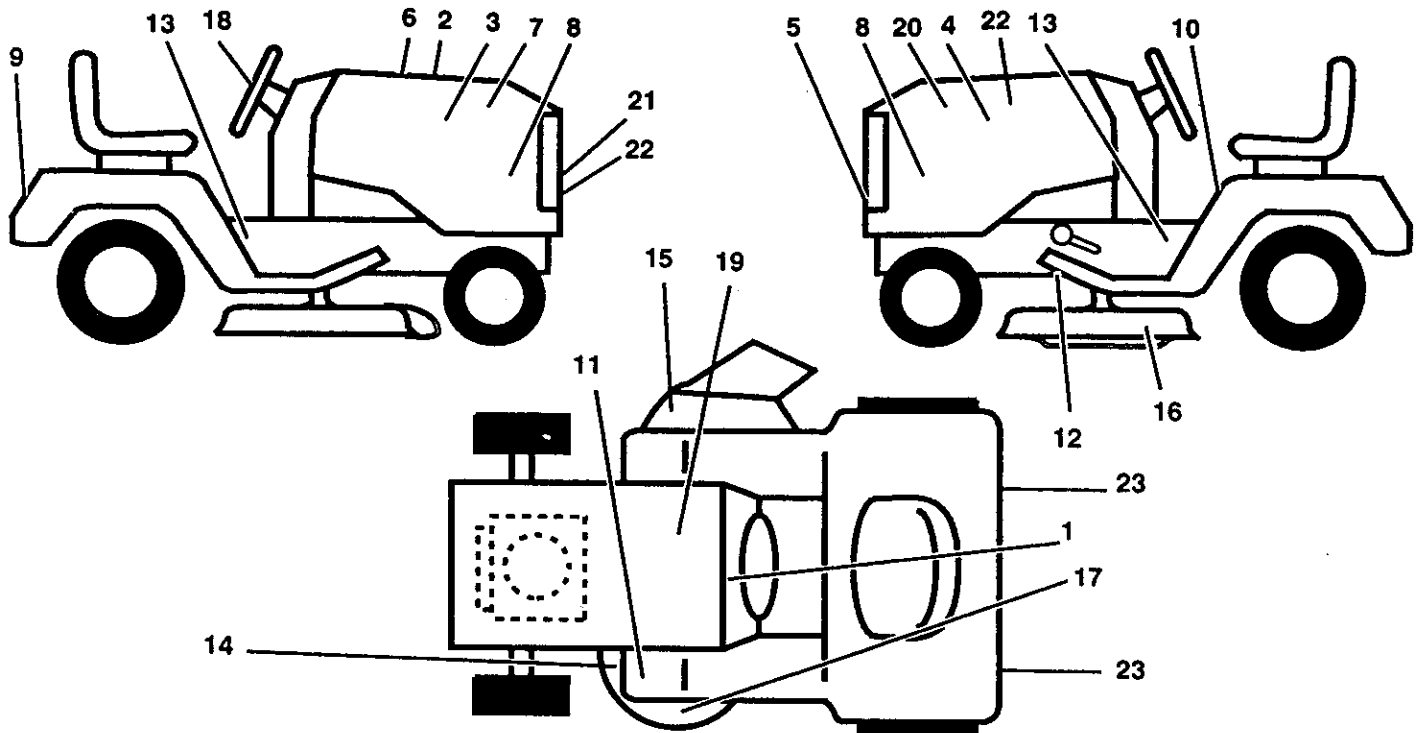

KEY NO.	PART NO.	DESCRIPTION	KEY NO.	PART NO.	DESCRIPTION
1	108456X	Decal Instruction Operat Eng	13	131473	Decal Chassis 6sp 42"
2	133178	Decal Mower 3 In One Conv	14	130981	Decal V-belt Schematic 42"eng
3	128490	Decal Hood Rh Craftsman Yt/gt	15	121343X	Decal Danger English
4	128491	Decal Hood Lh Craftsman Yt/gt	16	3713J	Decal Rota Blades English
5	105806X	Decal Grille (craftsman)	17	133179	Decal Mower Qc System
6	133644	Decal Maint Cust Sears Domesti	18	132268	Decal Insr Wh Strg Crafts Usa
7	106814X	Decal Stripe Panel Side Rh	19	120960X	Decal Battery Die Hard
8	133204	Decal Pnl Side Kohler Ohv 14hp	20	106813X	Decal Stripe Panel Side Lh
9	128314	Decal Fender Craftsman White	21	132271	Decal Lt4000 Usa
10	133796	Decal Caution English	22	128258	Decal Hood & Grille Lt4000
11	4900J	Decal Clutch/brake English	23	106202X	Reflector Taillight Red/amber
12	109199X	Decal V-belt Dr Sch Tractor E	--	133129	Manual Owners 255690 Eng

WHEELS & TIRES

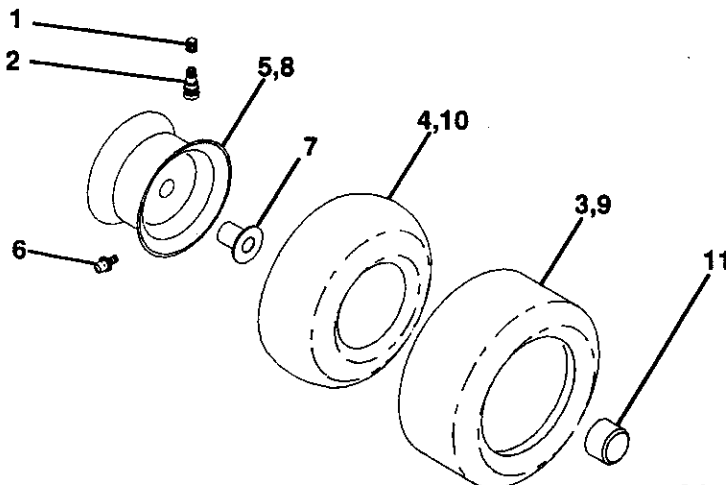

KEY NO.	PART NO.	DESCRIPTION
1	59192	Cap Valve Tire
2	65139	Stem Valve
3	106222X	Tire F Ts 15 x 6 0 - 6 Service
4	59904	Tube Front (Service Item Only)
5	106732X311	Rim Asm 6"front White Service
6	278H	Fitting Grease (Front Wheel Only)
7	9040H	Bearing Flange (Front Wheel Only)
8	106108X311	Rim Asm 8xrear White Service
9	124632X	Tire Rear (Service Item Only)
10	7152J	Tube Rear 9 5 x 8 Service
11	104757X	Cap Axle Blk 1 50 x 1 00

NOTE: All component dimensions given in U.S. inches
1 inch = 25.4 mm

REPAIR PARTS

14 HP 42" RIDING LAWN TRACTOR - - MODEL NUMBER 917.255690

ENGINE

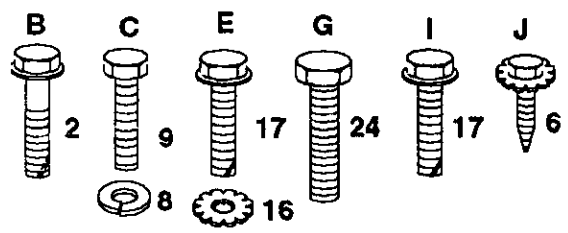
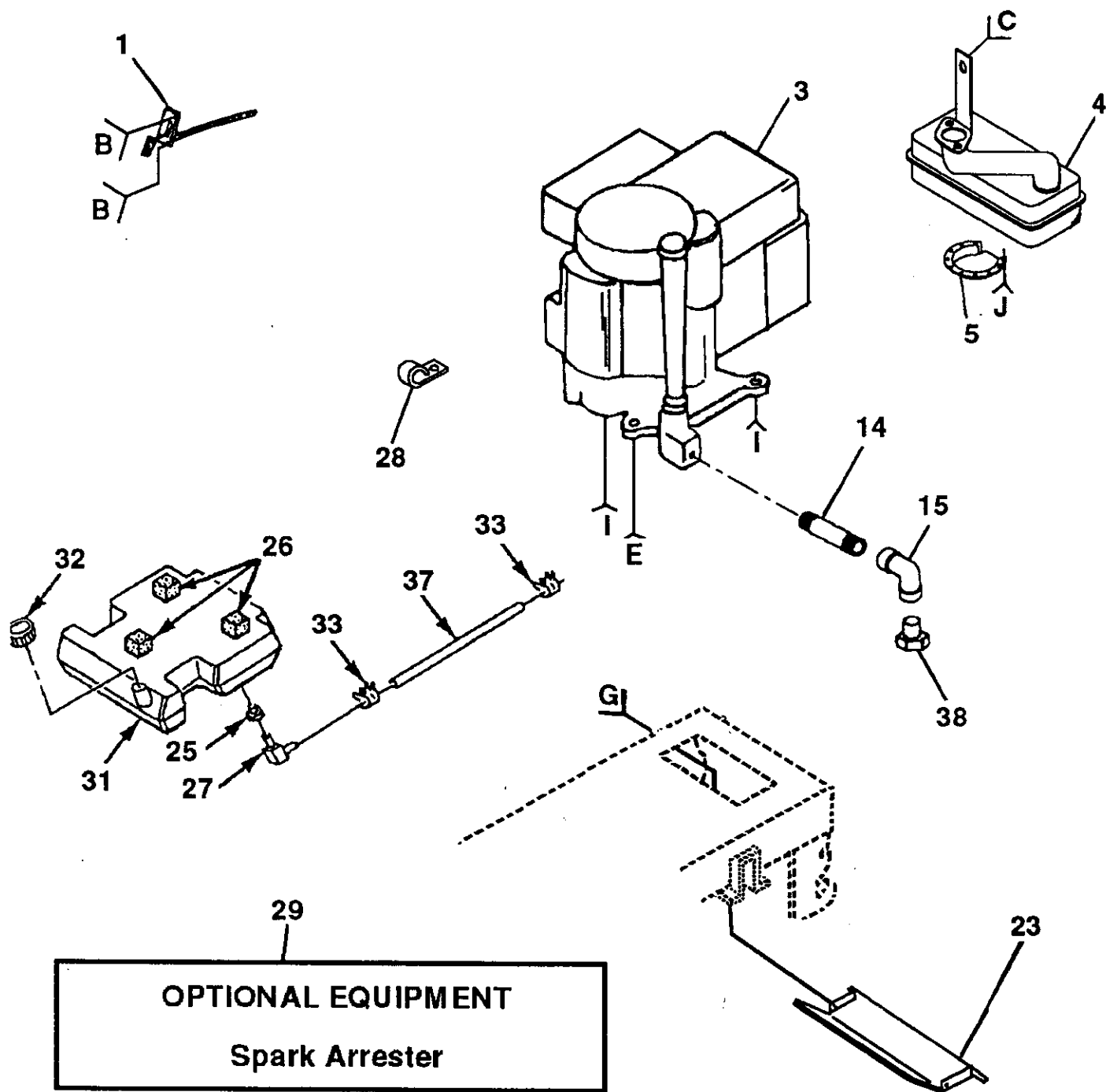

REPAIR PARTS

14 HP 42" RIDING LAWN TRACTOR - - MODEL NUMBER 917.255690

ENGINE

KEY NO.	PART NO.	DESCRIPTION
1	134265	Control Throt/ch Pdl Blk Rh 27
2	17720410	Screw Hex Thd Cut 1/4-20x5/8 T
3	132499	Engine Ko Com 14 15amp Vt W/fi
4	124196X	Muffler Exhaust Koh Lt Premium
5	101326L	Deflector Muffler # 222573
6	17030808	Screw Spiderloc Hexhd#8x1/2 Ab
8	STD551131	Lockwasher
9	STD523105	Bolt
14	13280336	Nipple Pipe 4-1/2"
15	13200300	Elbow Std 90 Degree 3/8-18 Npt
16	STD551231	Washer
17	M010208025	Screw M8 x 1 25 x 25mm
23	128953	Shield Heat Browning Grass
24	STD601005	Screw
25	3645J	Bushing
26	106082X	Spacer Pad 1 x 1 x 1 Blk
27	8710J	Stem Tank Fuel
28	2751R	Clip Line Fuel 13/32 Mtg Hole
29	121851X	Arrestor Spark
31	106020X	Tank Fuel 3 50 Rear
32	123549X	Cap Asm Fuel W/sym Vented
33	123487X	Clamp Hose Blk
37	8543R	Line Fuel 52"
38	-	Plug Oil Drain (Order From Engine Manufacturer)

NOTE: All component dimensions given in U.S. inches
1 inch = 25.4 mm

REPAIR PARTS

14 HP 42" RIDING LAWN TRACTOR - - MODEL NUMBER 917.255690

42" MOWER

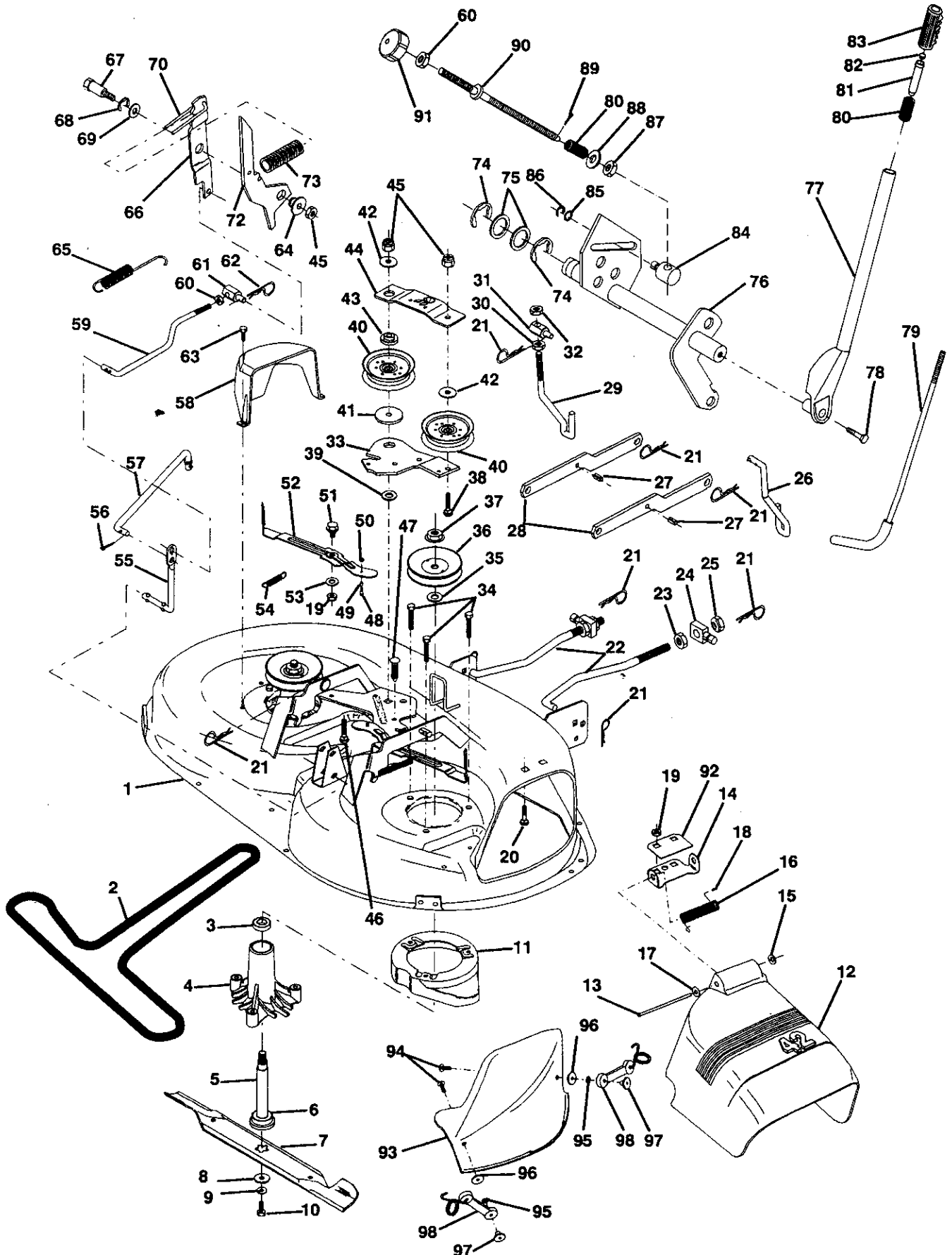

REPAIR PARTS

14 HP 42" RIDING LAWN TRACTOR - - MODEL NUMBER 917.255690

42" MOWER

KEY NO.	PART NO.	DESCRIPTION	KEY NO.	PART NO.	DESCRIPTION
1	130970	Deck Asm Mower 42"	52	131845	Arm Asm Pad Brake
2	130969	V-belt Mower 42" 92 40	53	133944	Washer Hardened Smaller
3	110485X	Bearing Ball Mandrel	54	131335	Spring Extension
4	128774	Housing Mandrel Vented(machd)	55	133551	Rod Pivot W/nibs
5	133172	Shaft Asm Mandrel Vented	56	STD560907	Cotter Pin
6	129895	Bearing Ball #6204 (mandrel)	57	133504	Rod Clutch Secondary W/nibs
7	134149	Blade Mulching 42"	58	131857	Guard Mandrel Lh 42"
8	129962	Washer Hard Blade Mower Vented	59	133550	Rod Clutch Primary W/nibs
9	STD551137	Lockwasher	60	STD541237	Nut
10	850857	Bolt 3/8-24x1 25 Gr8 Patched	61	133205	Trunnion Adj 3/8-16 Unc x 1 30
11	128961	Stripper Mower Vented	62	STD624003	Retainer
12	130968	Shield Deflector 42" Black	63	17720410	Screw Hex Thd Cut 1/4-20x5/8 T
13	131491	Rod Hinge 42"6 75 Wlg	64	127498	Bushing 747 Od x 794 Lg Brass
14	131267	Bracket Deflector Mower 42"	65	133435	Spring Ext Return Black
15	110452X	Nut Push Phos & Oil	66	127847	Arm Clutch Secondary
16	123713X	Spring Torsion Deflector 2 52	67	128903	Bolt Shoulder 3/8-16 Unc 1 44
17	19111016	Washer 11/32 x 5/8 x 16 Ga	68	12000029	Ring Klip #t5304-75
18	105304X	Cap Sleeve 80x 112 Blk Mower	69	121748X	Washer 25/32 x 1 5/8 x 16ga
19	STD541431	Nut	70	127845	Keeper Spring 4 000
20	STD533107	Bolt	72	127846	Arm Clutch Primary 3ga Lt/yt
21	STD624008	Ret Spring	73	128759	Spring Clutch Mower 2 750 Zinc
22	127218	Link Front	74	12000022	Ring E Truarc #5133-87
23	73350800	Nut Jam Hex 1/2-13 Unc	75	19292016	Washer 29/32 x 1-1/4 x 16 Ga
24	130171	Trunnion Blk Zinc	76	131926	Shaft Asm Lift Yt W/ind Dr/tp
25	STD541450	Nut	77	121002X	Lever Asm Lift Blk 23 85
26	127224	Link Lift Rh Blk Zinc 6 894 Lt	78	74780624	Bolt Fin Hex 3/8-16unc x 1-1/2
27	128763	Pin Spring Sstd 5/16 x 750	79	121006X	Rod Asm Lever
28	130832	Arm Suspension Rear	80	2876H	Spring 2-1/8"
29	127223	Link Lift Lh Blk Zinc 7 789 Lt	81	122364X	Plunger Lever Lift
30	STD541343	Nut	82	122365X	Button Plunger Red
31	110447X	Trunnion Lift W/ 451/ 461 ld	83	125631X	Grip Handle Fluted Blk
32	73710700	Nut Crownlock Jam 7/16-20 Unf	84	110810X	Trunnion Dp Stop Dbl Thds Plt
33	133844	Arm Idler 42"mower Lt/yt	85	19151216	Washer 15/32 x 3/4 x 16ga
34	78158	Bolt 5/16-18 x 1 25 T/t	86	12000037	Ring Klip #t5304-37
35	129963	Washer Spacer Mower Vented	87	110807X	Nut Special
36	129861	Pulley Mandrel 42"	88	STD551037	Washer
37	73050900	Nut 9/16top Lock Fing Oil Dip	89	STD560907	Pin
38	STD533717	Bolt	90	110729X	Rod Adj Lift Zinc 9 00 Wrk Lg
39	133943	Washer Hardened	91	100734K	Knob Infinite 3/8-16 Unc Black
40	131494	Pulley Idler Flat 3 060	92	134753	Stiffener Bracket 42deck
41	122052X	Spacer Retainer Pm Mower	93	134079	Mulcher Cover 42
42	19131612	Washer 13/32 x 1 x 12 Ga	94	71161010	Screw
43	133502	Spacer Arm Idler Upper Hdn 42	95	STD551110	Lockwasher
44	133503	Stiffener Arm Idler Upper 42"	96	19061216	Washer #10
45	STD541437	Nut	97	2029J	Nut Weld
46	72110618	Bolt Rdhd Sqnk 3/8-16 x 2-1/4	98	130758	Latch Asm Bagger
47	133835	Fastner Christmas Tree	--	133171	Deck Serv 42"mb Mech Sears Eng
48	131340	Bolt Shldr 10-24 Zinc Gr 5 42"			
49	133940	Roller Asm Cam Follower 42"dec			
50	STD541410	Nut-lock			
51	105529X	Bolt Shoulder 5/16-18 Unc Blkz			

NOTE: All component dimensions given in U.S. inches
1 inch = 25.4 mm

REPAIR PARTS

14 HP 42" RIDING LAWN TRACTOR - - MODEL NUMBER 917.255690
FOOTE/DANA TRANSAXLE - MODEL NUMBER 143.4360-37

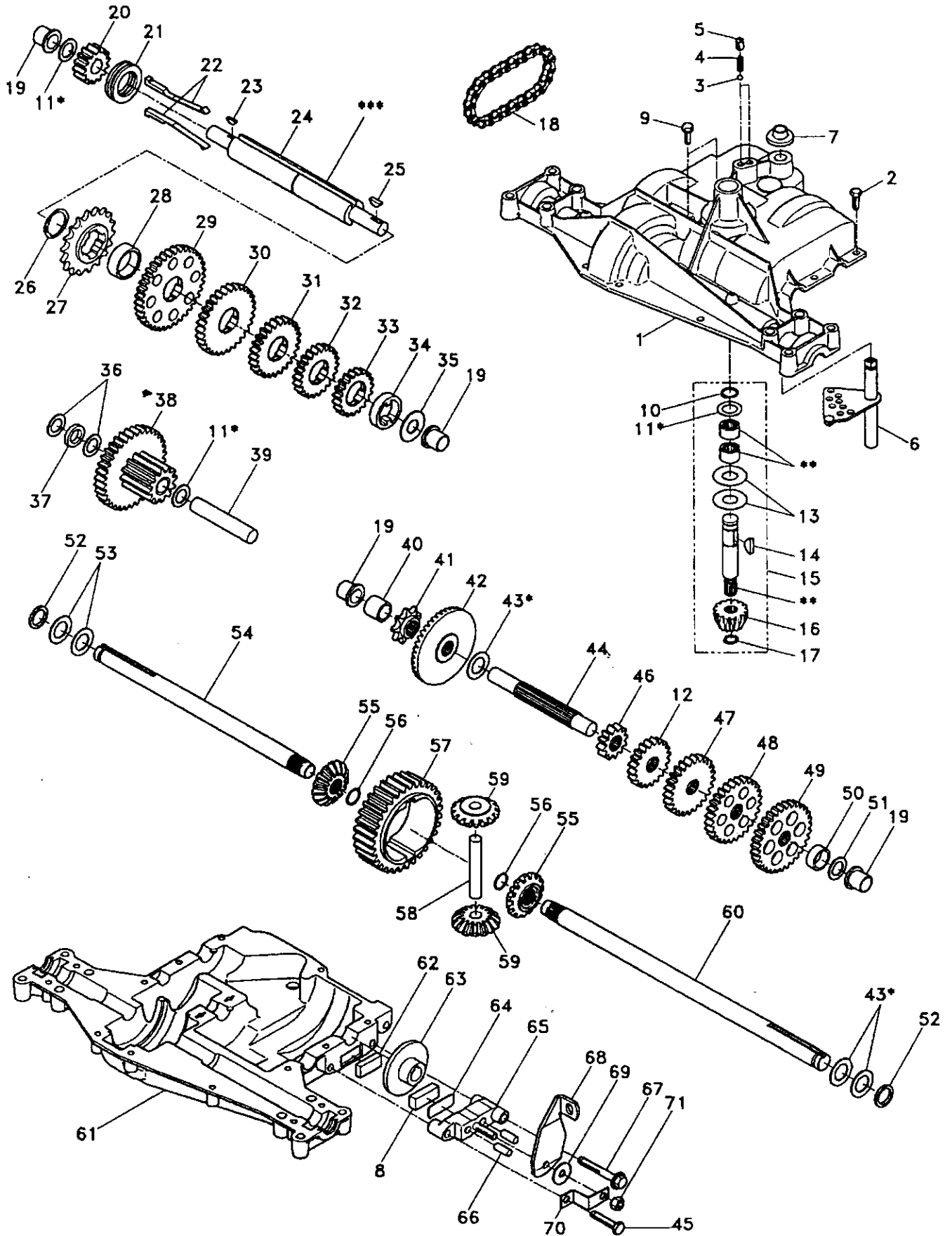

REPAIR PARTS

**14 HP 42" RIDING LAWN TRACTOR - - MODEL NUMBER 917.255690
FOOTE/DANA TRANSAXLE - MODEL NUMBER 143.4360-37**

KEY PART NO. NO.	DESCRIPTION	KEY PART NO. NO.	DESCRIPTION
1 124643X	Housing, Upper	42 106605X	Gear, Bevel, 42 Teeth
2 2274J	Screw, Tapping, Large 1/4-20 x .734	43 134394	Assembly, Kit, Shim, .750 Shaft
3 68003	Ball, Detent	44 120473X	Shaft, Drive
4 105904X	Spring, Detent	45 106596X	Screw, Tapping, Large 5/16-18 x 1.44
5 105905X	Screw, Set	46 105933X	Gear, Spur, 12 Teeth
6 134788	Kit, Shifter Assembly	47 120407X	Gear, Spur, 20 Teeth
7 134399	Boot, Shifter	48 106589X	Gear, Spur, 25 Teeth
8 120951X	Puck, Friction	49 120408X	Gear, Spur, 28 Teeth
9 134791	Screw, Tapping, w/Sealer	50 105937X	Gear, Spur, 31 Teeth
10 2267J	Ring, Retaining	51 2226J	Washer, Plain .632 x 1.00 x .060
11 134793	Assembly, Kit, Shim, .625 Shaft	52 134401	Washer, Neoprene
12 106151X	Gear, Spur, 15 Teeth	53 2264J	Washer, Plain .758 x 1.25 x .031
13 120415X	Washer, Plain .632 x 1.38 x .046	54 120474X	Axle, Left Hand
14 2257J	Key, Woodruff, #9	55 120409X	Gear, Miter, 15 Teeth
15 106846X	Assembly, Kit, Input Shaft	56 105941X	Ring, Retaining
16 106095X	Pinion, Bevel, 14 Teeth	57 110071X	Gear, Spur, 32 Teeth
17 105909X	Ring, Retaining	58 120952X	Shaft, Cross
18 105910X	Chain, 24 Pitches	59 106592X	Gear, Miter, 15 Teeth
19 105911X	Bearing, Flange	60 120475X	Axle, Right Hand
20 108976X	Gear, Spur, 14 Teeth	61 134798	Housing, Lower
21 105913X	Collar, Clutch	62 120961X	Puck, Friction
22 134795	Key, Clutch	63 7294J	Disc, Brake
23 2242J	Key, Woodruff, #3	64 108989X	Spacer
24 120469X	Shaft, Intermediate	65 120953X	Jaw, Brake
25 2244J	Key, Woodruff, #61	66 120954X	Pin, Dowel
26 105916X	Ring, Retaining	67 134799	Screw, Tapping 5/16-18 x 2.25
27 120470X	Sprocket, 18 Teeth	68 108992X	Lever, Actuating
28 110070X	Spacer	69 108996X	Washer, Plain .321 x 1.00 x .055
29 108977X	Gear, Spur, 37 Teeth	70 120956X	Bracket, Anti-Rotation
30 109254X	Gear, Spur, 35 Teeth	71 73810500	Locknut 5/16-24
31 124644X	Gear, Spur, 30 Teeth	72 120416X	Grease
32 108980X	Gear, Spur, 25 Teeth		
33 120406X	Gear, Spur, 22 Teeth		
34 134796	Gear, Spur, 19 Teeth		
35 105925X	Washer, Plain .640 x 1.37 x .061		
36 2232J	Washer, Plain .632 x 1.00 x .026		
37 108978X	Spacer .630 x 1.00 x .169		
38 110079X	Assembly, Gear, Combination, 12 Teeth and 35 Teeth		
39 124639X	Shaft, Idler		
40 120472X	Spacer .633 x .87 x .755		
41 105928X	Sprocket, 9 Teeth		

* Use in various combinations to maintain proper clearances.

** Order Key Number 15.

*** Lubricate with Aerospace Lubricant, Inc.
PC-8 Oil or equivalent.

NOTE: All component dimensions given in U.S. inches
1 inch = 25.4 mm

EPAIR PARTS

14 HP 42" RIDING LAWN TRACTOR - - MODEL NUMBER 917.255690

KOHLER ENGINE - MODEL NUMBER CV 14S, TYPE NUMBER 1445

AIR INTAKE

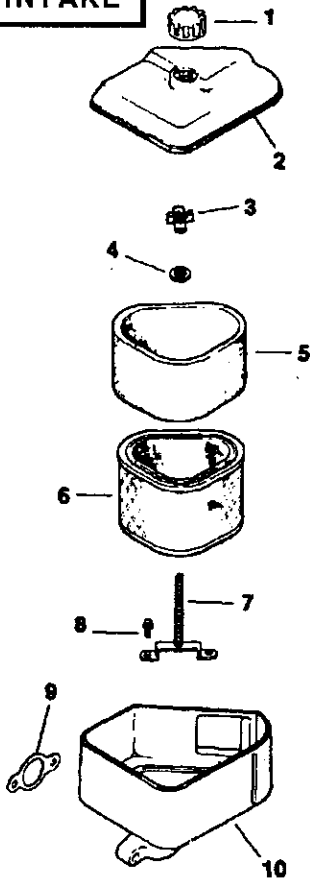

BLOWER HOUSING AND BAFFLES

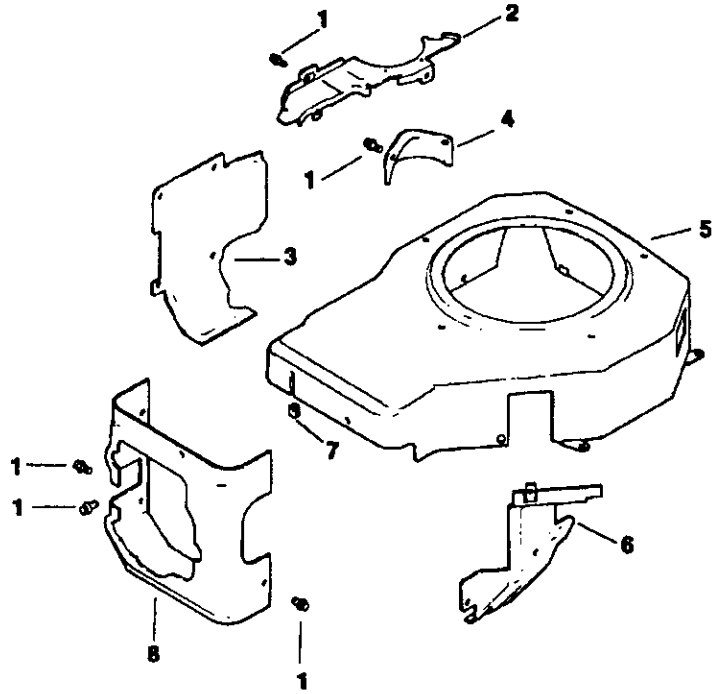

ENGINE CONTROLS

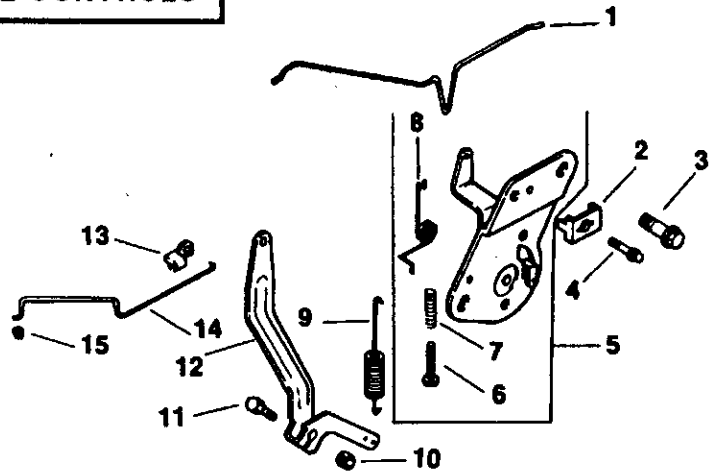

CRANKSHAFT

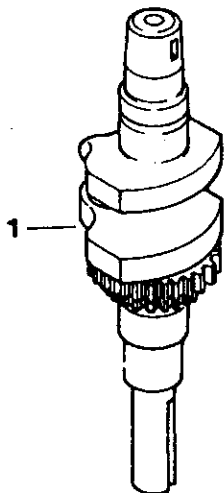

EXHAUST



REPAIR PARTS

14 HP 42" RIDING LAWN TRACTOR - - MODEL NUMBER 917.255690

KOHLER ENGINE - MODEL NUMBER CV 14S, TYPE NUMBER 1445

FUEL SYSTEM

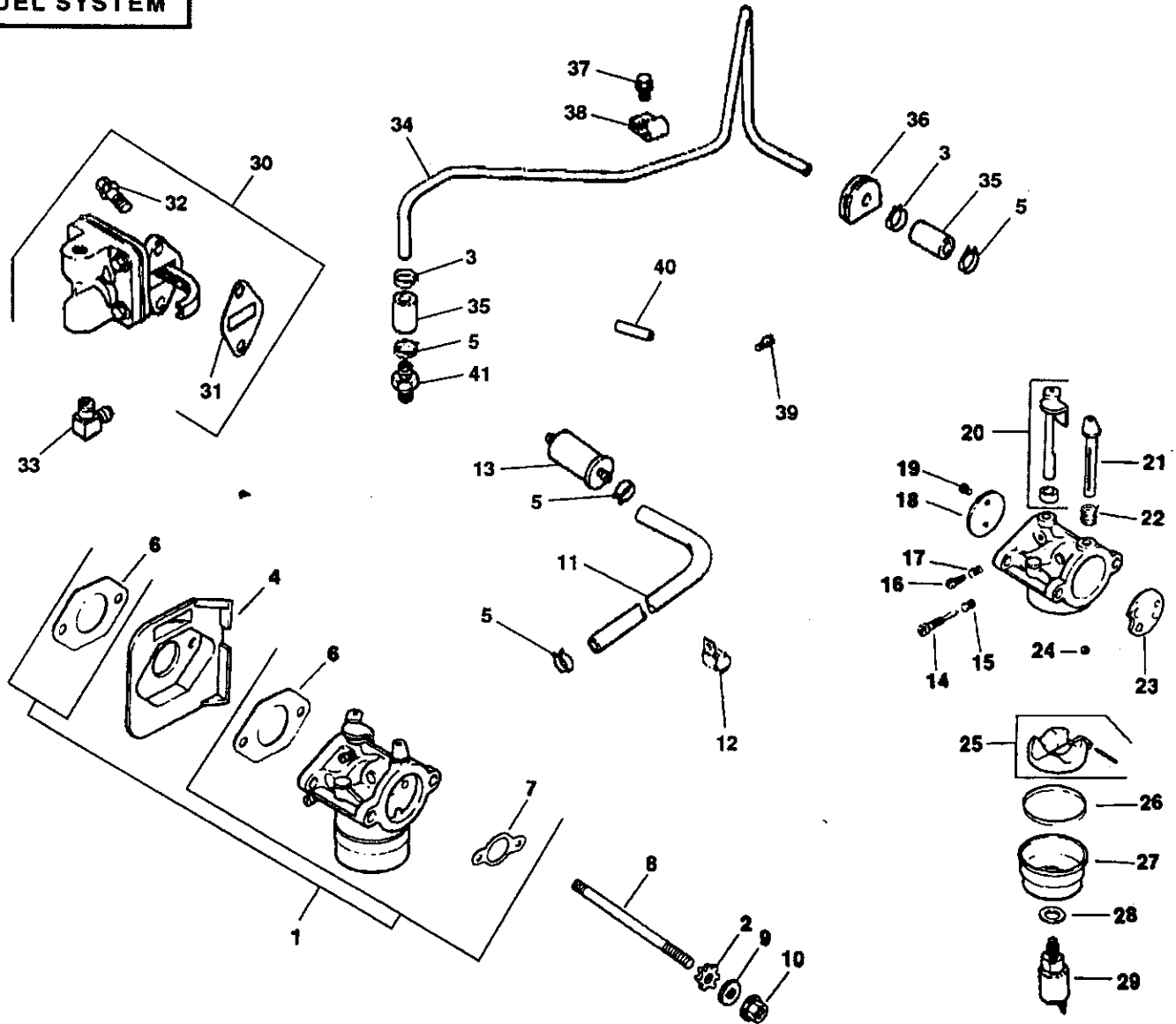

CYLINDER HEAD, VALVE AND BREATHER

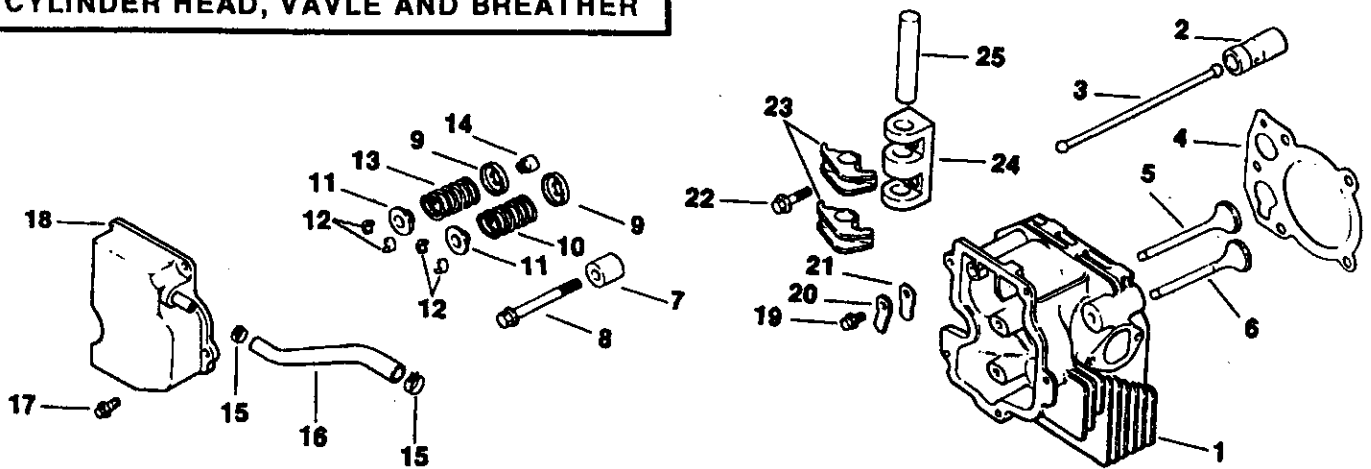

PAIR PARTS

14 HP 42" RIDING LAWN TRACTOR - - MODEL NUMBER 917.255690

KOHLER ENGINE - MODEL NUMBER CV 14S, TYPE NUMBER 1445

IGNITION / ELECTRICAL

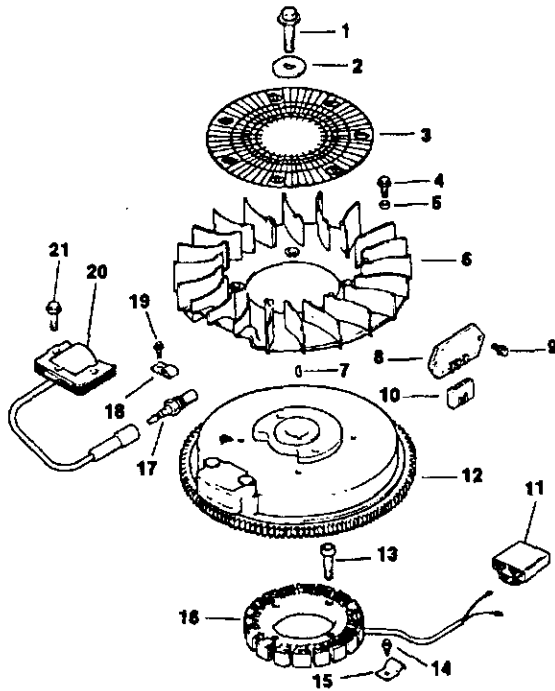

OIL PAN / LUBRICATION

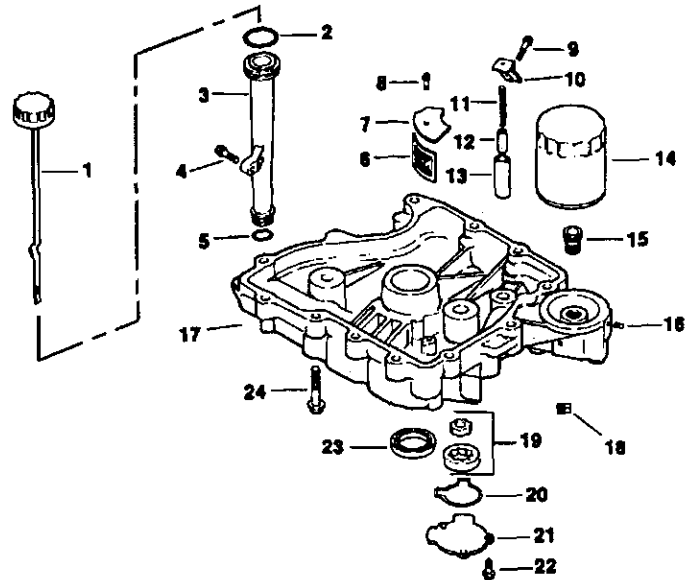

CRANKCASE

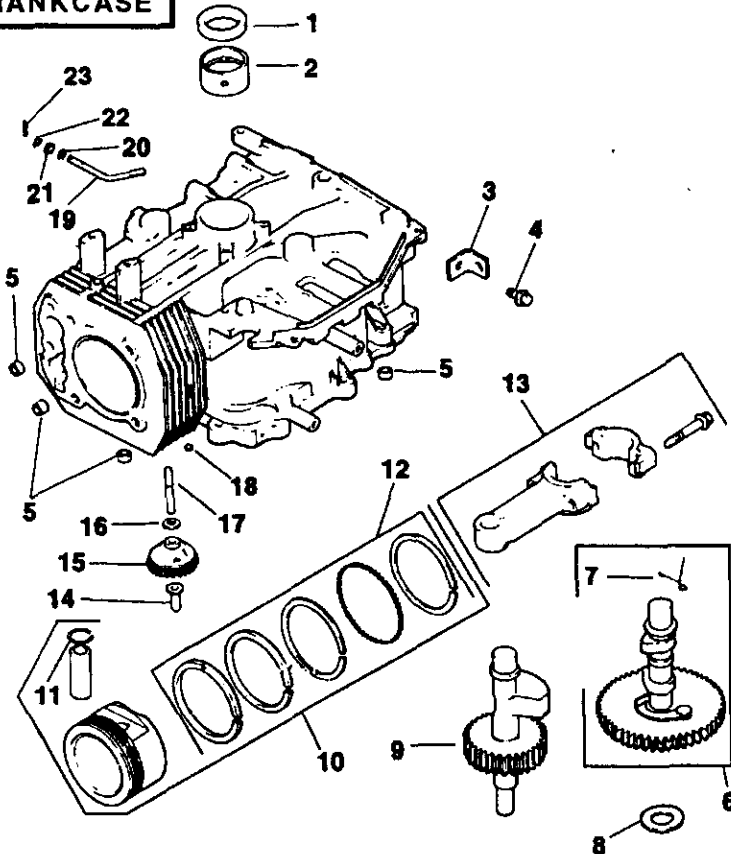

STARTING SYSTEM

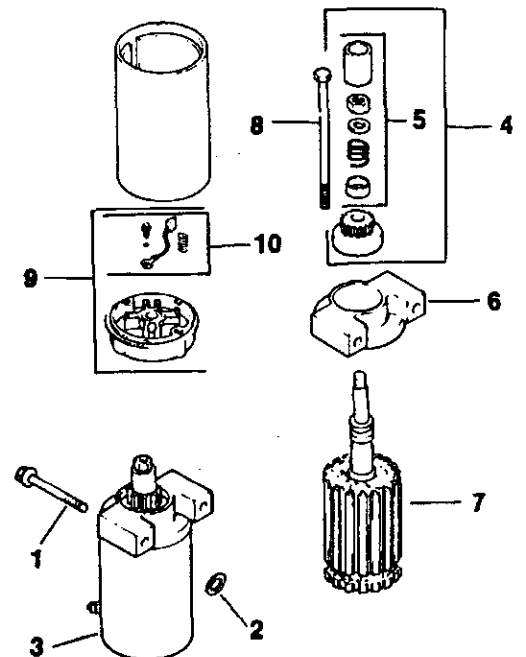

REPAIR PARTS

14 HP 42" RIDING LAWN TRACTOR - - MODEL NUMBER 917.255690

KOHLER ENGINE - MODEL NUMBER CV 14S, TYPE NUMBER 1445

AIR INTAKE

KEY PART NO. NO.	DESCRIPTION
1 12 341 01	Knob, Air Cleaner Cover
2 12 096 06	Cover, Air Cleaner
3 12 100 01	Wing Nut
4 X-25-63	Washer, Plain 1/4
5 12 083 08	Precleaner Element
6 12 083 05	Element, Air Cleaner
7 12 072 03	Stud, Mounting Plate
8 12 086 01	Screw, Mounting Plate Stud
9 12 041 02	Gasket, Air Cleaner
10 12 094 01	Base, Air Cleaner

EXHAUST

KEY PART NO. NO.	DESCRIPTION
1 M-0829036	Stud, Exhaust Manifold M8 x 1.25 x 20 (2)
2 12 041 03	Gasket, Exhaust Manifold
3 SM-0841080	Nut, Muffler Mounting M8 x 1.25 (2)
4 12 126 11	Bracket, Muffler
5 12 445 01	Strap, Lifting
6 SM-0645025	Screw, Lifting Strap M6 x 1.0 x 25 (3)

CRANKSHAFT

KEY PART NO. NO.	DESCRIPTION
1 12 014 02	Crankshaft
-- 12 522 02	Short Block
-- 12 755 01	Gasket Set

BLOWER HOUSING AND BAFFLES

KEY PART NO. NO.	DESCRIPTION
1 SM-0545010	Screw, Mounting M5 x 0.8 x 10 (14)
2 12 146 01	Plate, Blower Housing
3 12 063 01	Baffle, Cylinder Barrel
4 12 096 01	Cover, Starter
5 12 027 04	Housing, Blower
6 12 063 02	Baffle, Carburetor
7 12 313 03	Grommet, Blower Housing
8 12 063 03	Baffle, Cylinder Head

ENGINE CONTROLS

KEY PART NO. NO.	DESCRIPTION
1 12 079 03	Linkage, Choke
2 12 237 01	Clamp, Cable
3 SM-0645020	Screw, Hex Head M6 x 1.0 x 20 (2)
4 SM-0545016	Screw, Cable Clamp
5 12 536 01	Control, Speed Assembly (Includes Key Numbers 6 through 8)
6 SM-0443025	Screw
7 12 089 11	Spring
8 12 089 04	Spring, Choke Return
9 12 089 12	Spring, Governor
10 SM-0641060	Nut, Governor Arm M6 x 1.0
11 SM-0642025	Screw, Governor Arm M6 x 1.0 x 25
12 12 090 05	Lever, Governor
13 25 158 09	Bushing
14 12 079 01	Linkage, Throttle
15 25 158 08	Bushing

NOTE: All component dimensions given in U.S. inches
1 inch = 25.4 mm

PAIR PARTS

14 HP 42" RIDING LAWN TRACTOR - - MODEL NUMBER 917.255690

KOHLER ENGINE - MODEL NUMBER CV 14S, TYPE NUMBER 1445

FUEL SYSTEM

KEY PART NO. NO.	DESCRIPTION
1 12 853 08	Kit, Carburetor w/Gaskets (Includes Key Numbers 6, 7, and 14-29, and all Kits marked *)
2 X-22-11	Washer, Star 1/4
3 25 237 02	Clamp, Hose (2)
4 12 265 01	Deflector, Heat
5 X-426-9	Clamp, Hose (4)
6 12 041 01	Gasket, Carburetor (2)
7 12 041 02	Gasket, Air Cleaner
8 M-0629122	Stud, Carburetor M6 x 1.0 x 110 (2)
9 X-25-63	Washer, Plain 1/4
10 SM-0641060	Nut, Carburetor M6 x 1.0 (2)
11 52 353 22	Fuel Line
12 47 154 01	Clip, Cable
13 25 050 02	Filter, Fuel
14 12 368 01	Needle, Idle
15 12 089 09	Spring, Idle Speed
16 12 086 04	Screw, Idle Speed Adjust
17 12 089 09	Spring, Idle Fuel
18 12 146 03	Plate, Throttle
19 25 086 27	Screw, Throttle Plate (2)
20 12 144 09	Shaft, Throttle with Lever and Seal
21 12 144 08	Shaft, Choke
22 12 089 10	Spring, Choke Return
23 12 146 02	Plate, Choke
24 12 337 01	Jet, Main
25 12 757 02	Kit, Float
26 12 041 05	Gasket, Bowl
27 12 104 01	Bowl, Fuel
28 12 041 06	Gasket, Bowl Retainer Screw
29 12 086 05	Screw, Fuel Bowl
30 12 559 01	Kit, Fuel Pump (Includes Key #31)
31 25 041 09	Gasket, Fuel Pump
32 SM-0645020	Screw, Fuel Pump M6 x 1.0 x 20 (2)
33 25 155 02	Connector, Hose
34 12 123 01	Line, Fuel, Metal
35 12 353 01	Line, Fuel, Rubber (2)
36 12 313 01	Grommet, Fuel Line
37 SM-0545010	Screw, Fuel Line Clamp
38 12 154 01	Clamp, Fuel Line
39 12 086 07	Screw, Ground Wire
40 12 431 01	Sleeve, Insulating
41 X-380-1	Connector, Hose

NOT ILLUSTRATED

12 757 01	*Kit, Carburetor Repair
12 755 09	*Kit, High Altitude Jet
12 435 02	*Solenoid Assembly, Fuel
12 518 05	Lead, Solenoid, Black, 5", 14 Gauge Uninsulated Push-On Tabs
41 518 34	Lead, Ground, Green, 5", 18 Gauge Insulated Grip Barrel Eyelets

CYLINDER HEAD, VALVE AND BREATHER

KEY PART NO. NO.	DESCRIPTION
1 12 318 01	Head, Cylinder
2 12 351 01	Lifter, Valve (2)
3 12 411 01	Rod, Push (2)
4 12 041 04	Gasket, Cylinder Head
5 12 017 01	Valve, Intake, Standard Size
12 017 02	Valve, Intake .25" oversize
6 12 016 01	Valve, Exhaust, Standard
12 016 02	Valve, Exhaust .25" oversize
7 12 112 04	Spacer, Head Bolt Exhaust Port
8 M-1040080	Screw, Cylinder Head M10 x 1.5 x 80 (5)
9 52 018 01	Retainer, Spring (2)
10 12 089 15	Spring, Exhaust Valve, Green
11 12 173 01	Cap, Valve Spring (2)
12 12 755 03	Kit, Retainer (2)
13 12 089 01	Spring, Intake Valve
14 12 032 02	Seal, Valve Stem
15 X-426-9	Clamp, Hose (2)
16 12 326 03	Hose, Breather
17 SM-0645020	Screw, Valve Cover M6 x 1.0 x 20 (3)
18 12 096 07	Cover, Valve with Nipple
19 SM-0545010	Screw, Breather Reed Retainer M5 x 0.8 x 1
20 12 018 01	Retainer, Breather Reed
21 12 402 01	Reed, Breather
22 SM-0642025	Screw, Rocker Bridge M6 x 1.0 x 25 (2)
23 12 186 01	Arm, Rocker (2)
24 12 126 05	Bridge, Rocker Arm
25 12 144 03	Shaft, Rocker Arm

NOT ILLUSTRATED

12 755 02	Kit, Cylinder Head
-----------	--------------------

NOTE: All component dimensions given in U.S. inches
1 inch = 25.4 mm

REPAIR PARTS

14 HP 42" RIDING LAWN TRACTOR - - MODEL NUMBER 917.255690

KOHLER ENGINE - MODEL NUMBER CV 14S, TYPE NUMBER 1445

IGNITION / ELECTRICAL

KEY PART NO. NO.	DESCRIPTION
1 SM-1040045	Screw, Flywheel Mounting
2 12 468 03	Washer, Flywheel Mounting Screw
3 12 162 01	Screen, Grass
4 SM-0639016	Screw, Fan Mounting (4)
5 12 112 01	Spacer, Fan (4)
6 12 157 01	Fan
7 X-42-15	Key
8 41 403 09	Rectifier-Regulator
9 SM-0639016	Screw, Rectifier-Regulator M6 x 1.0 x 16 (2)
10 236602	Connector, Rectifier-Regulator
11 236473	Connector, 3 Contact
12 12 025 01	Flywheel Assembly
13 SM-0544025	Screw, Stator Mounting M5 x 0.8 x 25 (4)
14 SM-0545010	Screw, Stator Harness Clip M5 x 0.8 x 10
15 12 154 02	Clip, Stator Harness
16 41 085 07	Stator, 15 Amp
17 12 132 02	Spark Plug
18 X-728-1	Clip, Kill Lead
19 SM-0545010	Screw, Lead Clip
20 12 584 01	Module, Ignition
21 SM-0545020	Screw, Ignition Module M5 x 0.8 x 20 (2)
NOT ILLUSTRATED	
25 518 05	Lead, Black, Rectifier To Connector 5"-14 Gauge, Uninsulated Push-on Tab Terminals
12 518 01	Lead, White, Ground To Kill

OIL PAN / LUBRICATION

KEY PART NO. NO.	DESCRIPTION
1 12 038 01	Dipstick
2 12 153 02	O-Ring, Upper Oil Fill Tube
3 12 123 04	Tube, Oil Fill
4 SM-0545020	Screw, Oil Fill Tube M5 x 0.8 x 20
5 12 153 01	O-Ring, Lower Oil Fill Tube
6 12 162 02	Screen, Oil Pick-up
7 12 096 03	Cover, Oil Pick-up Screen
8 SM-0545016	Screw, Screen Cover
9 SM-1039025	Screw, Oil Pump Relief Valve Bracket M10 x 1.5 x 25
10 12 126 02	Bracket, Oil Pump Relief Bracket
11 12 089 03	Spring, Oil Pump Relief Valve
12 12 462 01	Piston, Oil Pump Relief Valve
13 12 208 01	Body, Oil Pump Relief Valve
14 12 050 02	Filter, Oil
15 12 136 01	Adapter
16 X-75-23	Plug
17 12 199 09	Pan, Oil
18 X-75-10	Plug, Solid Sq. Hd. 3/8 NPTF (2)
19 12 393 01	Pump, Oil
20 12 032 04	O-Ring, Oil Pump Cover
21 12 096 02	Cover, Oil Pump
22 SM-0545016	Screw, Oil Pump Cover M5 x 0.8 x 16 (3)
23 12 032 03	Seal, Oil (P.T.O. End)
24 SM-0839045	Screw, Oil Pan M8 x 1.25 x 45 (12)

CRANKCASE

KEY PART NO. NO.	DESCRIPTION
-- ---	Block, Cylinder (Use Short Block, Part Number 12 522 02)
1 12 032 03	Seal, Crankshaft
2 12 030 01	Bearing, Crankshaft, Standard (Flywheel End)
12 030 02	Bearing, Crankshaft .25" oversize
12 030 03	Bearing, Crankshaft .50" oversize
3 12 445 02	Strap, Lifting
4 SM-0839025	Screw, Lifting Strap
5 12 380 03	Dowel, Locating (4)
6 12 010 02	Camshaft Assembly (Includes #7)
7 12 089 05	Spring, Actuating
8 12 422 01	Shim, Camshaft
12 422 02	Shim, Camshaft (as required)
12 422 03	Shim, Camshaft (as required)
12 422 11	Shim, Camshaft (as required)
12 422 12	Shim, Camshaft (as required)
12 422 06	Shim, Camshaft (as required)
12 422 07	Shim, Camshaft (as required)
9 12 144 04	Shaft, Balance
10 12 874 01	Piston w/Ring Set, Standard
12 874 02	Piston w/Ring Set .25" oversize
12 874 03	Piston w/Ring Set .50" oversize
11 12 018 02	Retainer, Piston Pin (2)
12 12 108 01	Ring Set, Standard
12 108 02	Ring Set .25" oversize
12 108 03	Ring Set .50" oversize
13 12 067 01	Connecting Rod, Standard
12 067 02	Connecting Rod .25" oversize
14 12 380 01	Pin, Governor Regulating
15 12 043 05	Gear, Governor Assembly
16 SM-0631005	Washer, Governor Gear Thrust
17 12 144 02	Shaft, Governor Gear
18 52 139 09	Plug, Cup
19 12 144 01	Shaft, Governor Cross
20 SM-0631015	Washer, Governor Shaft
21 12 032 01	Seal, Governor Cross Shaft
22 X-25-102	Washer, Plain
23 12 380 04	Pin, Governor Hitch

STARTING SYSTEM

KEY PART NO. NO.	DESCRIPTION
1 SM-0839065	Screw, Bendix Starter M8 x 1/25 x 65.5 (2)
2 12 468 01	Washer (2)
3 12 098 05	Starter Assembly (Includes #4-10)
4 12 755 12	Kit, Drive (Includes Key Number 5)
5 12 755 06	Kit, Drive Parts
6 12 227 01	Cap, Drive End
7 12 170 02	Armature
8 12 086 02	Screw, Hex Flange
9 12 243 01	Cap, Commutator End (Includes Key Number 10)
10 48 755 15	Kit, Brush
NOT ILLUSTRATED	
52 357 01	Lubricant, Starter

NOTE: All component dimensions given in U.S. inches
1 inch = 25.4 mm

SERVICE NOTES

SERVICE NOTES

SERVICE NOTES

SUGGESTED GUIDE FOR SIGHTING SLOPES FOR SAFE OPERATION

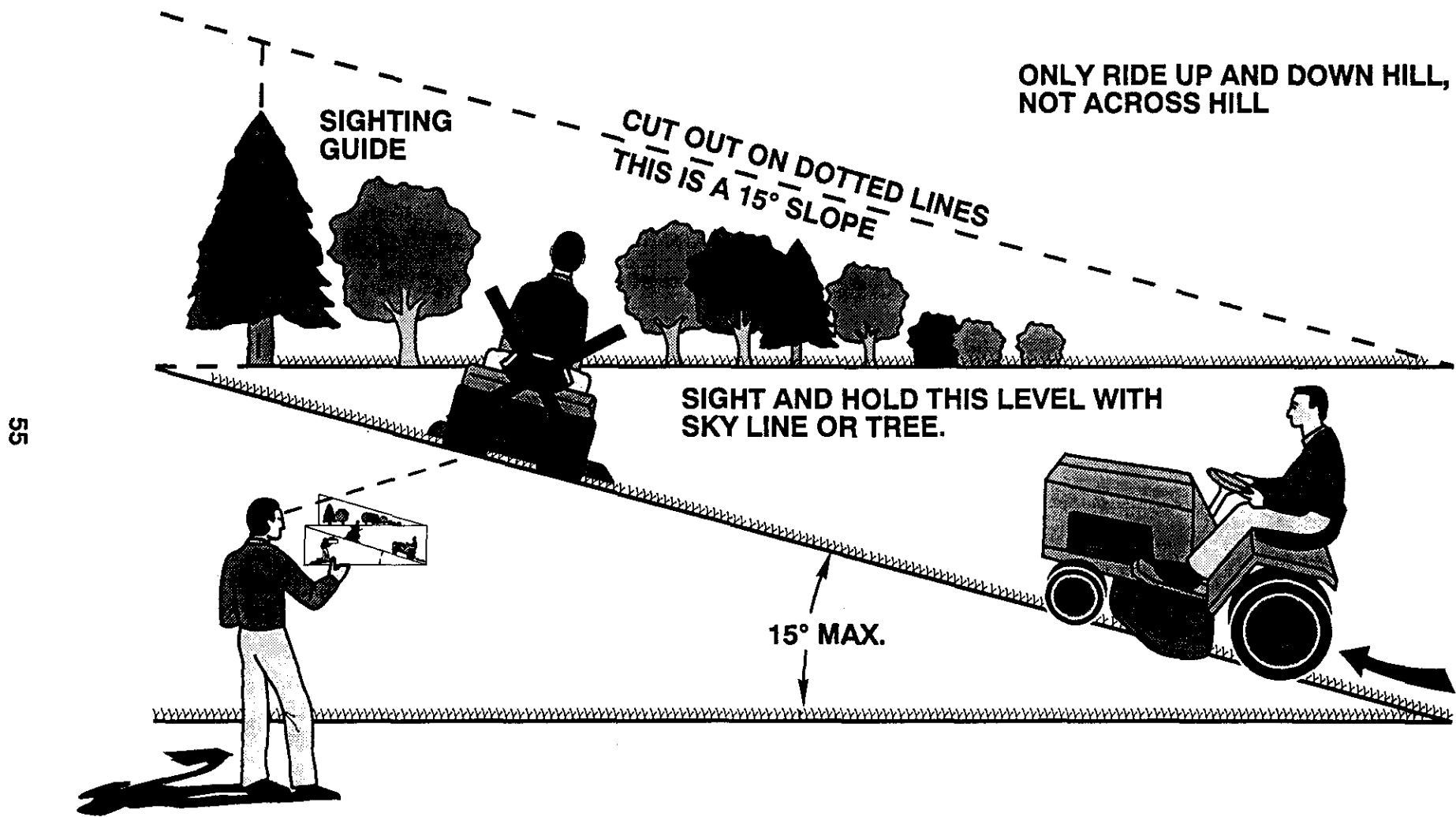

 Operate your Tractor up and down the face of slopes (not greater than 15°), never across the face. Make turns gradually to prevent tipping or loss of control. Exercise extreme caution when changing direction on slopes.

SEARS

OWNER'S MANUAL

MODEL NO. 917.255690

HOW TO ORDER REPAIR PARTS

CRAFTSMAN[®]

14.0 HP OHV ELECTRIC START 3 in One Convertible 42" MOWER DECK 6 SPEED TRANSAXLE LAWN TRACTOR

Each tractor has its own model number. Each engine has its own model number.

The model number for your tractor will be found on the model plate located under the seat.

The model number for your engine will be found on the blower housing.

All parts listed herein may be ordered from any Sears, Roebuck and Co. Service Centers and most Retail Stores.

WHEN ORDERING REPAIR PARTS, ALWAYS GIVE THE FOLLOWING INFORMATION:

- **PRODUCT - LAWN TRACTOR**
- **MODEL NUMBER - 917.255690**
- **ENGINE MODEL NUMBER - CV 14, TYPE NUMBER PS 1445**
- **PART NUMBER**
- **PART DESCRIPTION**

Your Sears merchandise has added value when you consider Sears has service units nationwide staffed with Sears trained technicians... professional technicians specifically trained to insure that we meet our pledge to you, we service what we sell.

Sears, Roebuck and Co., Chicago, IL 60684 U.S.A.