

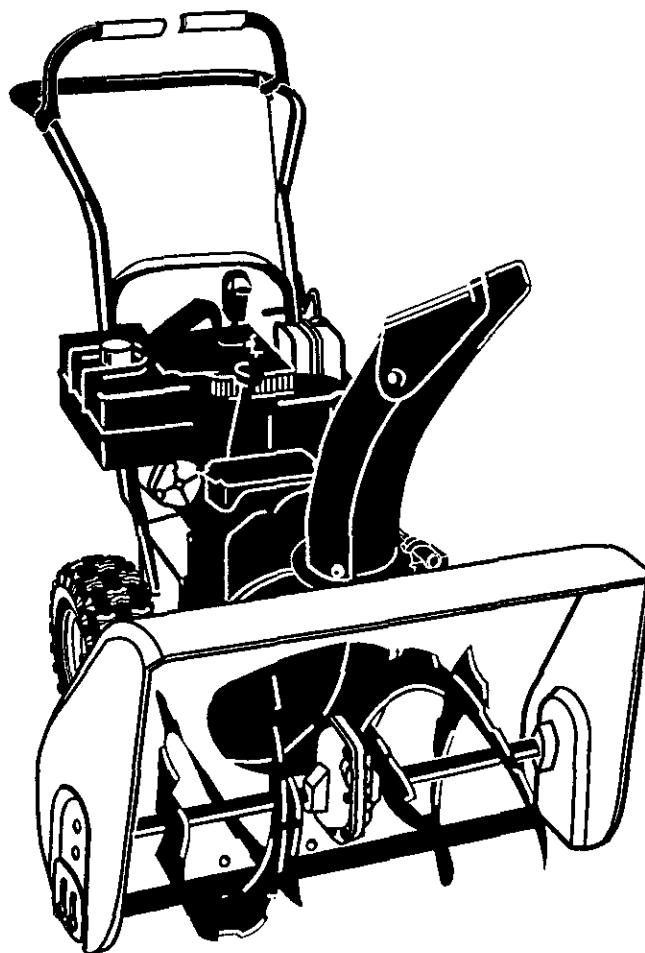

**5 Horsepower
24 Inch Dual Stage
120V. Electric Start
SNOW THROWER**

**MODEL NO.
536.886440**



Caution:

**Read and follow all Safety Rules
and Operating Instructions before
first use of this product.**

SEARS, ROEBUCK AND CO., Hoffman Estates, IL 60179 U.S.A.

F-001087J

SAFETY

ASSEMBLY

OPERATION

MAINTENANCE

PARTS LIST

ESPOÑOL

TABLE OF CONTENTS

WARRANTY STATEMENT	2	STORAGE	28
SAFETY RULES	2	TROUBLE SHOOTING CHART ..	29
INTERNATIONAL SYMBOLS	4	REPAIR PARTS	30
ASSEMBLY	6	ENGINE REPAIR PARTS	46
OPERATION	11	SPANISH (ESPAÑOL)	55
MAINTENANCE	17	PARTS ORDERING/SERVICE ..	
SERVICE AND ADJUSTMENT ..	20		BACK COVER

WARRANTY STATEMENT

LIMITED TWO-YEAR WARRANTY ON CRAFTSMAN SNOW THROWER

For two years from the date of purchase, when this Craftsman Snow thrower is maintained, lubricated, and tuned up according to the operating and maintenance instructions in the owner's manual, Craftsman will repair, free of charge, any defect in material or workmanship.

If this Craftsman Snow thrower is used for commercial or rental purposes, this warranty applies for only 90 days from the date of purchase.

This warranty does not cover the following:

- Items which become worn during normal use, such as spark plugs, drive belts and shear pins.
- Repair necessary because of operator abuse or negligence, including bent crankshafts and the failure to maintain the equipment according to the instructions contained in the owner's manual.

WARRANTY SERVICE IS AVAILABLE BY RETURNING THE CRAFTSMAN SNOW THROWER TO THE NEAREST CRAFTSMAN SERVICE CENTER/DEPARTMENT IN THE UNITED STATES. THIS WARRANTY APPLIES ONLY WHILE THIS PRODUCT IS IN USE IN THE UNITED STATES.

This warranty gives you specific legal rights, and you may also have other rights which may vary from state to state.

Sears, Roebuck and Co., D817WA, Hoffman Estates. IL 60179

SAFETY RULES



LOOK FOR THIS SYMBOL TO POINT OUT IMPORTANT SAFETY PRECAUTIONS. IT MEANS— ATTENTION!!! BECOME ALERT!!! YOUR SAFETY IS INVOLVED.



WARNING:



Engine Exhaust, some of its constituents, and certain vehicle components contain or emit chemicals known to the State of California to cause cancer and birth defects or other reproductive harm.

Battery posts, terminals and related accessories contain lead and lead compounds, chemicals known to the State of California to cause cancer and birth defects or other reproductive harm. **WASH HANDS AFTER HANDLING.**



WARNING: Always disconnect the spark plug wire and place it where it cannot make contact with spark plug to prevent accidental starting during: Preparation, Maintenance, or Storage of your snow thrower.

IMPORTANT: Safety standards require operator presence controls to minimize the risk of injury. Your snow thrower is equipped with such controls. Do not attempt to defeat the function of the operator presence control under any circumstances.

TRAINING

1. Read the operating and service instruction manual carefully. Be thoroughly familiar with the controls and the proper use of the equipment. Know how to stop the unit and disengage the controls quickly.
2. Never allow children to operate the equipment. Never allow adults to operate the equipment without proper instruction.
3. Keep the area of operation clear of all persons, particularly small children and pets.
4. Exercise caution to avoid slipping or falling especially when operating in reverse.

PREPARATION

1. Thoroughly inspect the area where the equipment is to be used and remove all doormats, sleds, boards, wires, and other foreign objects.
2. Disengage all clutches before starting the engine (motor).
3. Do not operate the equipment without wearing adequate winter outer garments. Wear footwear that will improve footing on slippery surfaces.
4. Handle fuel with care; it is highly flammable.
 - a. Use an approved fuel container.
 - b. Never remove fuel tank cap or add fuel to a running engine (motor) or hot engine (motor).
 - c. Fill fuel tank outdoors with extreme care. Never fill fuel tank indoors.
 - d. Replace fuel cap securely and wipe up spilled fuel.
 - e. Never store fuel or snow thrower with fuel in the tank inside of a building where fumes may reach an open flame or spark.
 - f. Check fuel supply before each use, allowing space for expansion as the heat of the engine (motor) and/or sun can cause fuel to expand.
5. For all units with electric starting motors use electric starting extension cords certified CSA/UL. Use only with a receptacle that has been installed in accordance with local inspection authorities.
6. Adjust the snow thrower height to clear gravel or crushed rock surface.
7. Never attempt to make any adjustments while the engine (motor) is running (except when specifically recommended by manufacturer).
8. Let engine (motor) and snow thrower adjust to outdoor temperatures before starting to clear snow.

9. Always wear safety glasses or eye shields during operation or while performing an adjustment or repair to protect eyes from foreign objects that may be thrown from the snow thrower.

OPERATION

1. Do not operate this machine if you are taking drugs or other medication which can cause drowsiness or affect your ability to operate this machine.
2. Do not use this machine if you are mentally or physically unable to operate this machine safely.
3. Do not put hands or feet near or under rotating parts. Keep clear of the discharge opening at all times.
4. Exercise extreme caution when operating on or crossing gravel drives, walks or roads. Stay alert for hidden hazards or traffic.
5. After striking a foreign object, stop the engine (motor), remove the wire from the spark plug, thoroughly inspect snow thrower for any damage, and repair the damage before restarting and operating the snow thrower.
6. If the unit should start to vibrate abnormally, stop the engine (motor) and check immediately for the cause. Vibration is generally a warning of trouble.
7. Stop the engine (motor) whenever you leave the operating position, before unclogging the auger/impeller housing or discharge chute and when making any repairs, adjustments, or inspections.
8. When cleaning, repairing, or inspecting, make certain the auger/impeller and all moving parts have stopped and all controls are disengaged. Disconnect the spark plug wire and keep the wire away from the spark plug to prevent accidental starting.
9. Take all possible precautions when leaving the snow thrower unattended. Disengage the auger/impeller, stop engine (motor), and remove key.
10. Do not run the engine (motor) indoors, except when starting the engine (motor) and for transporting the snow thrower in or out of the building. Open the outside doors; exhaust fumes are dangerous (containing CARBON MONOXIDE, an ODORLESS and DEADLY GAS).
11. Do not clear snow across the face of slopes. Exercise extreme caution when changing direction on slopes. Do not attempt to clear steep slopes.
12. Never operate the snow thrower without proper guards, plates or other safety protective devices in place.

13. Never operate the snow thrower near enclosures, automobiles, window wells, drop-offs, and the like without proper adjustment of the snow discharge angle. Keep children and pets away.
14. Do not overload the machine capacity by attempting to clear snow at too fast a rate.
15. Never operate the machine at high transport speeds on slippery surfaces. Look behind and use care when backing up.
16. Never direct discharge at bystanders or allow anyone in front of the unit.
17. Disengage power to the collector/impeller when snow thrower is transported or not in use.
18. Use only attachments and accessories approved by the manufacturer of the snow thrower (such as tire chains, electric start kits, ect.).
19. Never operate the snow thrower without good visibility or light. Always be sure of your footing and keep a firm hold on the handles. Walk; never run.
20. Do not over-reach. Keep proper footing and balance at all times.
21. Do not attempt to use snow thrower on a roof.

MAINTENANCE AND STORAGE

1. Check shear bolts and other bolts at frequent intervals for proper tightness to be sure the equipment is in safe working condition.
2. Never store the snow thrower with fuel in the tank inside a building where ignition sources are present such as hot water and space heaters, clothes dryers, and the like. Allow the engine (motor) to cool before storing in any enclosure.
3. Always refer to operator's guide instructions for important details if the snow thrower is to be stored for an extended period.
4. Maintain or replace safety and instruction labels, as necessary.
5. Run the snow thrower a few minutes after throwing snow to prevent freeze-up of the auger/impeller.



WARNING: This snow thrower is for use on sidewalks, driveways and other ground level surfaces.

Caution should be exercised while using on steep sloping surfaces. DO NOT USE SNOW THROWER ON SURFACES ABOVE GROUND LEVEL such as roofs of residences, garages, porches or other such structures or buildings.

IMPORTANT: Many of the following symbols are located on your unit or on literature supplied with the product. Before you operate the unit, learn and understand the purpose for each symbol.

Control And Operating Symbols



Slow



Fast



Electric Start



Engine Start



Engine Run



Engine Off



Engine Stop



On



Choke Off



Choke On



Neutral



Throttle



Primer Button

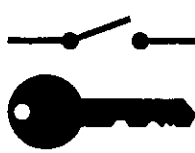

Ignition Key



Ignition Off



Ignition On

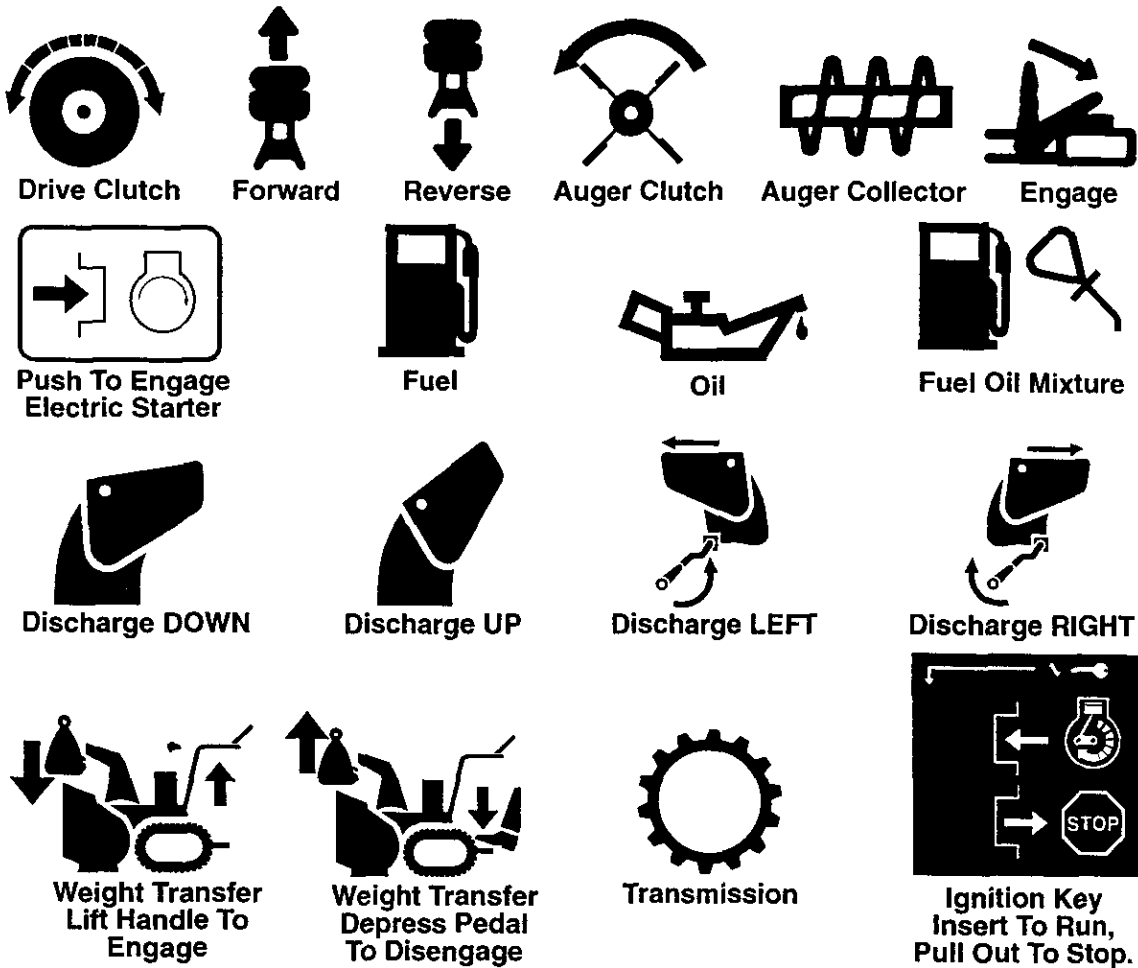

Safety Warning Symbols

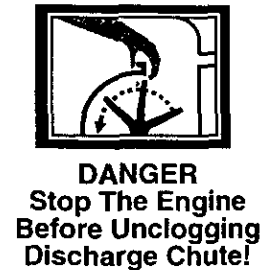

ASSEMBLY

Contents of Parts Bag (actual size)

- 1 – Owner's Manual (not shown)
- 1 – Packet of Fuel Stabilizer (not shown)
- 1 – Warranty Card (not shown)
- 2 – Parts bags (not shown)

*Non-Assembly Parts, found in toolbox located on belt cover

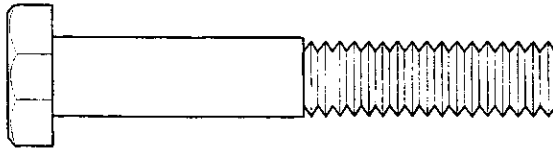

1– Screw, 5/16–18 x 2 in

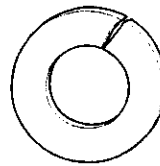

1–Split Lockwasher

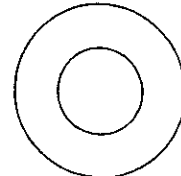

1–Flatwasher
11/32In.

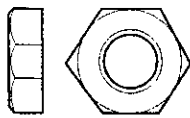

1– Nut, 5/16–18

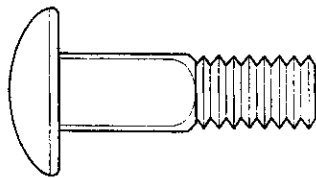

3– 5/16–18 Carriage Bolts

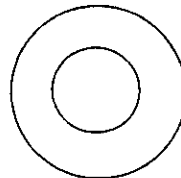

3– 11/32
Flatwashers

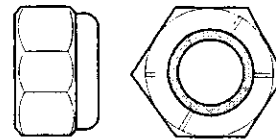

3– 5/16–18
Nylon Hex Nuts

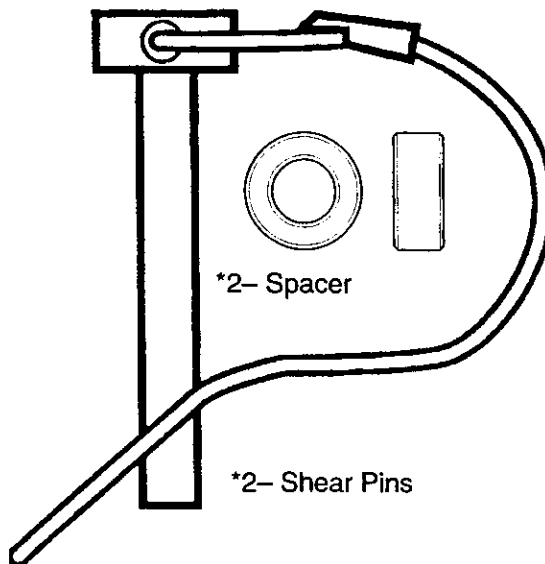

*2– Spacer

*2– Shear Pins

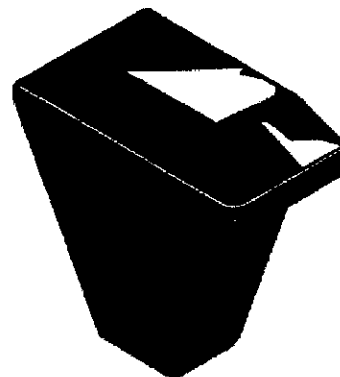

1 – Shift Lever Knob
(not actual size)

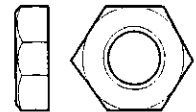

1 – 1/4–20
Hex Jam Nut

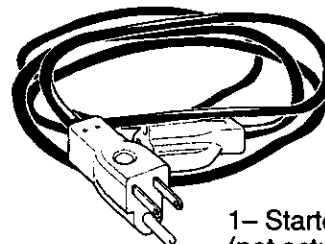

1– Starter Cord
(not actual size)

ASSEMBLY

Parts packed separately in carton (not shown full size)



2- Ignition Keys
(Attached to engine in plastic bag)

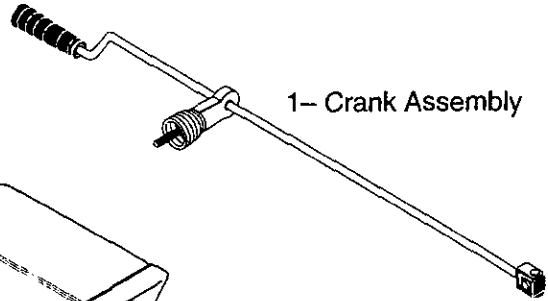

1- Crank Assembly

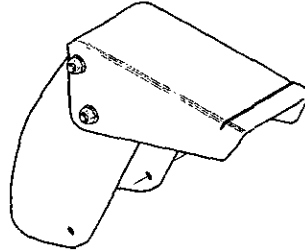

1-Snow Chute Assembly



WARNING: Always wear safety glasses or eye shields while assembling snow thrower.

TOOLS REQUIRED FOR ASSEMBLY

- 1 - Knife to cut carton
- 1 - 1/2 inch wrenches (or adjustable wrenches)
- 1 - 9/16 inch wrenches (or adjustable wrenches)
- 1 - 3/4 inch wrenches (or adjustable wrenches)
- 1 - Pliers (to spread cotter pin)
- 1 - Screwdriver
- 1 - Measuring tape or ruler

Figure 1 shows the snow thrower in the shipping position.

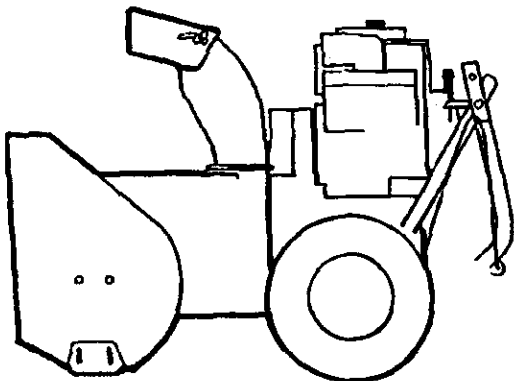

Figure 1

F-001087J

Figure 2 shows the snow thrower completely assembled. References to the right or left hand side of the snow thrower are from the viewpoint of the operator's position behind the unit.

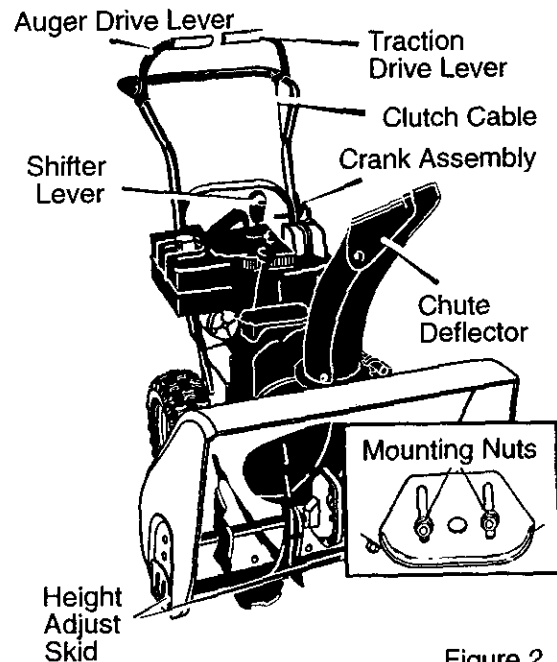

Figure 2

TO REMOVE SNOW THROWER FROM CARTON

1. Locate all parts packed separately and remove from the carton.

NOTE: Place fuel stabilizer in a safe place until needed for storage.

ASSEMBLY

2. Remove and discard the packing material from around the snow thrower.
3. Cut down all four corners of the carton and lay the panels flat.
4. Roll snow thrower off the carton by pulling on the lower handle. **CAUTION: DO NOT** back over cables.
5. Remove the packing material from handle assembly.
6. Cut ties securing the clutch control cables to the lower handle and lay cable back away from the motor frame.

TO ASSEMBLE THE HANDLE AND CRANK ASSEMBLY

1. Cut tie holding shift rod to lower handle and move shifter to the first forward gear.
2. Loosen, but do not remove, the screws, flatwashers, lockwashers, and hex nuts in the upper holes of the lower handle. See Figure 3.

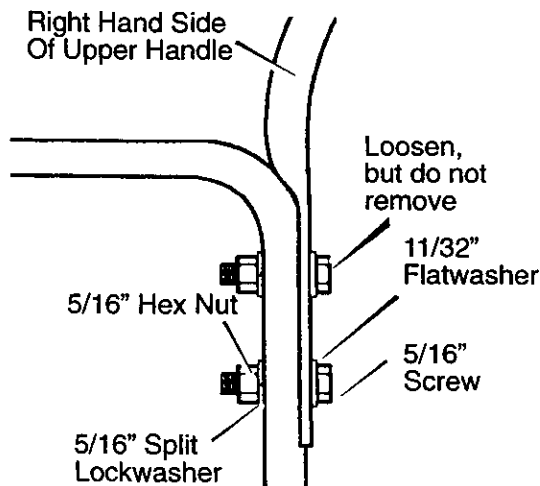

Figure 3

NOTE: Make sure the cables are not caught between the upper and lower handle.

3. Raise the upper handle into operating position. Upper handle should be to the outside of the lower handle.

F-001087J

NOTE: If the cables have become disconnected from the clutch levers, reinstall the cables as shown in Figure 4.

NOTE: Position cable through slots on shifter plate.

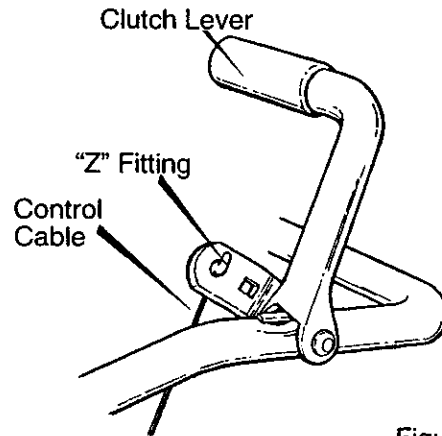

Figure 4

4. Install hardware supplied in the parts bag (**screw, flatwasher, lockwasher, and hex nut**) into bottom hole on right hand side of handles. **DO NOT** tighten until all bolts are in place.
5. Locate **crank assembly** removed earlier and remove the **nylon locknut and flatwasher** from the **eye bolt assembly**. See Figure 5.

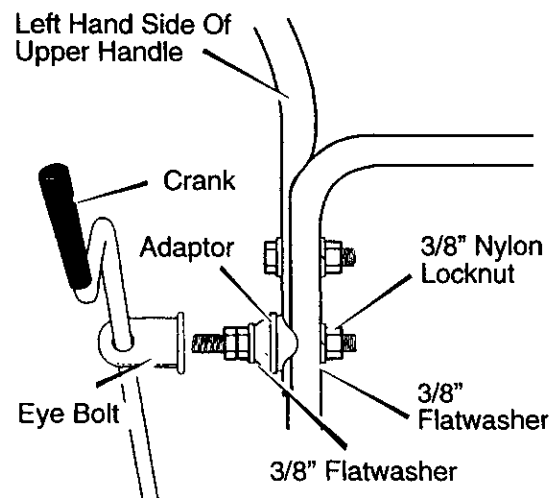
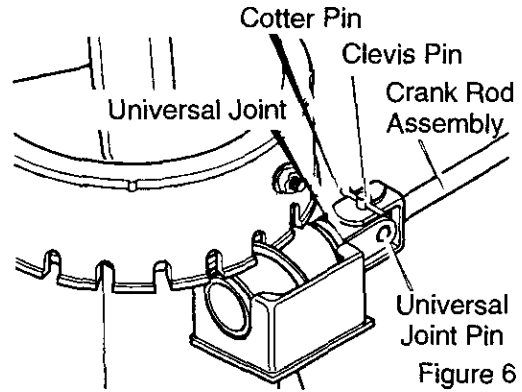

Figure 5

6. Reinstall **flatwasher and adaptor**. Install **eye bolt** through lower hole on the left hand side of the handle.

ASSEMBLY

7. Install the $\frac{3}{8}$ " flatwasher and the $\frac{3}{8}$ " nylon locknut loosely on the eye bolt.
8. Carefully remove **cotter pin**, **clevis pin** and **universal joint pin** from yoke end of **crank rod assembly**. See Figure 6.
9. Place **universal joint** into end of worm gear lining up large holes. Insert **universal joint pin** (ensure opening in pin is in line with small openings in universal joint).
10. Place yoke end of **crank rod** around **universal joint**, lining up openings. Insert clevis pin through assembly and secure with **cotter pin**.
11. Tighten nut on **eye bolt**. Make sure **eye bolt** is properly aligned and the **crank can freely rotate**.
12. Tighten all handle bolts.



TO INSTALL SHIFTER KNOB

1. Thread the $\frac{1}{2}$ -13 hex jam nut found in parts bag onto the threaded end of the **shifter lever**. See Figure 7.
2. Thread the **shifter lever knob** onto the threaded end of the **shifter lever** until it is snug against the **hex jam nut** and the lip is pointed away from the engine. Tighten the **hex jam nut** against the bottom of the **shifter lever knob** to lock in position.

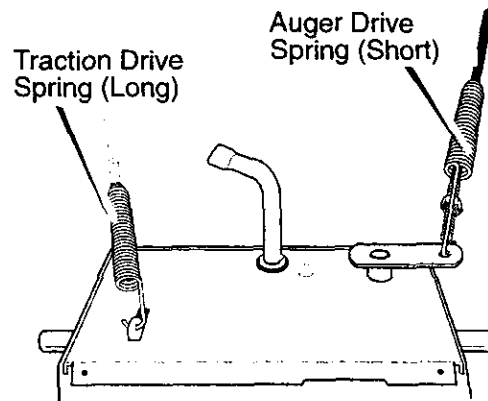
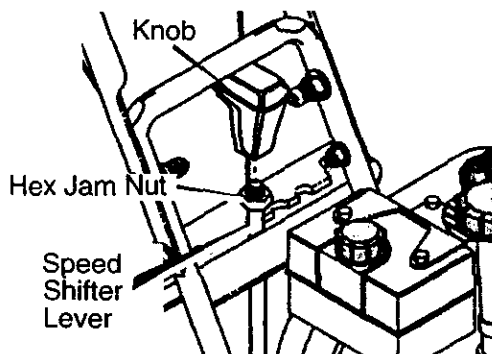

NOTE: If the cables have become disconnected, reinstall springs as shown in Figure 8.

F-001087J

ASSEMBLY

SNOW CHUTE ASSEMBLY

1. Turn crank assembly counterclockwise until it stop.
2. Position **snow chute** on inside of snow chute **flange** and align the three holes in the **snow chute** with holes on snow chute **flange**. (See Figure 9)
3. Place three **5/16–18 carriage bolts** from inside of chute as shown in Figure 9. (hardware is found in parts bag).
4. Place three **5/16–18 flatwashers** and three **5/16–18 nuts** on outside of flange.
5. Tighten all **four carriage bolts** securely.

NOTE: DO NOT overtighten carriage bolts.

6. Turn crank assembly clockwise and make sure all carriage bolts are tight.

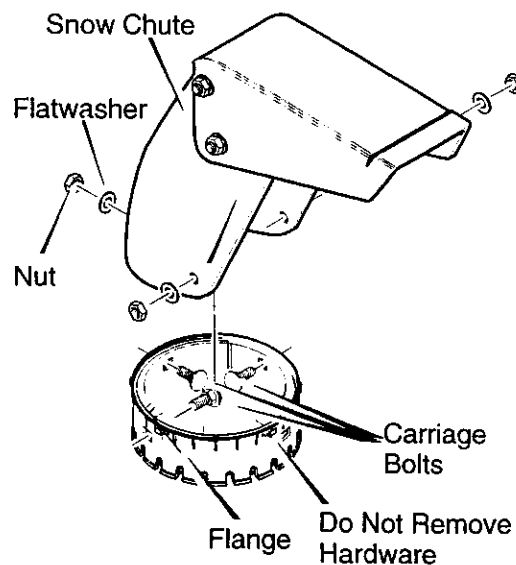

Figure 9

HOW TO SET THE SKID HEIGHT

Your snow thrower is equipped with height adjust skids on the outside of the auger housing. To adjust the skid

height for different conditions, see **To Adjust Skid Height** paragraph in the **Service And Adjustment** section.

✓ CHECKLIST

Before you operate your new snow thrower, to ensure that you receive the best performance and satisfaction from this quality product, please review the following checklist:

- ✓ All assembly instructions have been completed.
- ✓ The discharge chute rotates freely.
- ✓ No remaining loose parts in carton.

While learning how to use your snow thrower, pay extra attention to the following important items:

- ✓ Engine oil is at proper level.
- ✓ Make sure gas tank is filled properly with clean, fresh, unleaded gasoline.
- ✓ Become familiar with all controls—their location and function. Operate controls before starting engine.

OPERATION

KNOW YOUR SNOW THROWER

READ THIS OWNER'S MANUAL AND SAFETY RULES BEFORE OPERATING YOUR SNOW THROWER. Compare the illustrations with your SNOW THROWER to familiarize yourself with the location of various controls and adjustments. Save this manual for future reference.

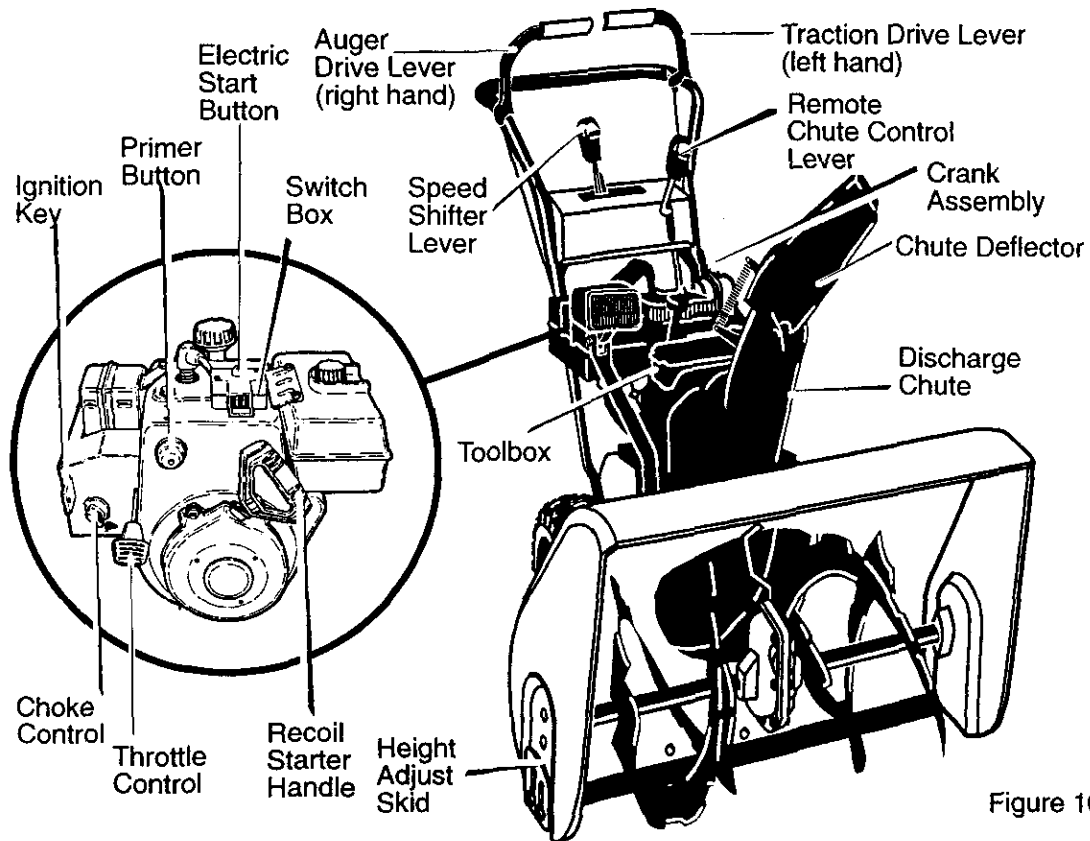

Auger Drive Lever – Starts and stops the auger and impeller (**snow gathering and throwing**)

Traction Drive Lever – Propels the snow thrower forward and in reverse.

Speed Shifter Lever – Selects the speed of the snow thrower (6 speeds forward and 2 speeds reverse).

Crank Assembly – Changes the direction of snow throwing through the discharge chute.

Chute Deflector – Changes the distance the snow is thrown.

Discharge Chute – Changes the height and direction the snow is thrown.

Height Adjust Skid – Adjusts the ground clearance of the auger housing.

Ignition Key – Must be inserted to start the engine.

Recoil Starter Handle – Starts the engine manually.

F-001087J

Choke Control – Used to start a cold engine.

Primer Button – Injects fuel directly into the carburetor manifold for fast starts in cold weather.

Remote Chute Control Lever – Push forward to discharge snow high and far. Pull remote lever back to discharge snow down.

Throttle Control – Controls the engine speed.

Electric Start Button – (if so equipped) Used to start the engine using the 120 V electric starter.

Shear Pin – Shear pins are designed to break (to protect the machine) if an object becomes lodged in the auger housing.

Toolbox – spare shear pins and spacers are located in toolbox.

OPERATION

The operation of any snow thrower can result in foreign objects being thrown into the eyes, which can result in severe eye damage. Always wear safety glasses or eye shields while operating the snow thrower.

We recommend standard safety glasses or a wide vision safety mask for over your glasses.



WARNING: Read Owner's Manual before operating machine. Never direct discharge toward bystanders stop the engine before unclogging discharge chute or auger housing and before leaving the machine.

TO STOP YOUR SNOW THROWER

1. To stop throwing snow, release the **auger drive lever**. See Figure 10.
2. To stop the wheels, release the **traction drive lever**.
3. To stop the engine, push the **throttle control lever** to off and pull out the ignition key.

TO CONTROL SNOW DISCHARGE

1. Turn the chute control rod to set the direction of the snow throwing.
2. Loosen the **wing knob** on the chute deflector and move the deflector to set the distance. Move the deflector (**Up**) for more distance, (**Down**) for less distance. Then tighten the **wing knob** (See Figure 11).

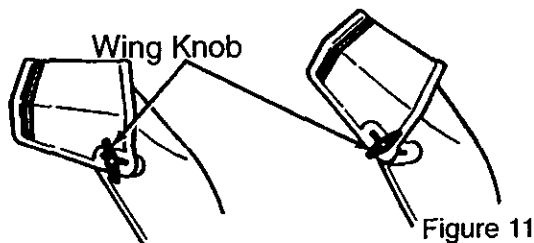

Figure 11

HOW TO MOVE FORWARD AND BACKWARD

1. To shift, release the traction drive lever (**left hand**) and move the speed shifter lever to the speed you desire. Ground speed is determined by snow conditions. Select

the speed you desire by moving the speed shifter lever left into the appropriate notches on the shift lever plate:

Speeds 1,2 – Wet, Heavy

Speed 3 – Light

Speed 4 – Very Light

Speed 5,6 – Transport only

2. Engage the traction drive lever (**left hand**). As the snow thrower starts to move, maintain a firm hold on the handles, and guide the snow thrower along the clearing path. Do not attempt to push the snow thrower.
3. To move the snow thrower backward, move the speed shifter lever right into first or second reverse and engage the traction drive lever (**left hand**).

IMPORTANT: Do not move the speed shifter lever while the traction lever is down.

TO THROW SNOW

1. Push down the auger driver lever (**right hand**).
2. Release to stop throwing snow.

TO USE WHEEL LOCKOUT PIN

1. The left hand wheel is secured to the axle with a **klick pin**. This unit was shipped with this klick pin in the **locked position (through wheel hole)**. See Figure 12.

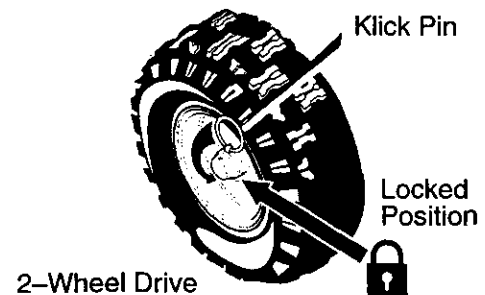
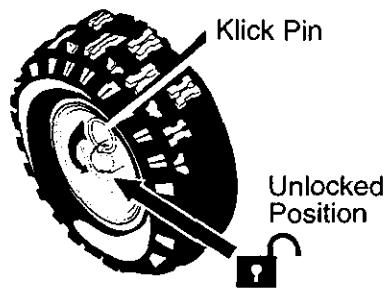

Figure 12

2. For ease of maneuverability in light snow conditions, disconnect the **klick pin** from the wheel **locked position** and push into the single wheel drive position (**unlocked axle hole only**). See Figure 13.

OPERATION



Single Wheel Drive

Figure 13

NOTE: Make sure that the klick pin is in the single wheel drive position of the axle only and not through the locked position.

BEFORE STARTING THE ENGINE

1. Before you service or start the engine, familiarize yourself with the snow thrower. Be sure you understand the function and location of all controls.
2. Check the tension of clutch cable before starting the engine. See **To Adjust The Control Cable** paragraph in the **Service & Adjustments** section of this manual.
3. Be sure that all fasteners are tight.
4. Make sure the height adjust skids are properly adjusted. See **To Adjust Skid Height** paragraph in the **Service & Adjustments** section of this manual.
5. Check tire pressure (14–17 pounds). Do not exceed maximum amount of pressure.

CHECK THE OIL:

NOTE: The engine was shipped from the factory filled with oil. Check the level of the oil. Add oil as needed.

1. Make sure the unit is level.
NOTE: Do not check the level of the oil while the engine runs.
2. Remove the oil fill cap/dipstick. Check the oil.
3. If necessary, add oil until the oil reaches the FULL mark on the oil fill cap/dipstick (see Figure 14). Do not add too much oil.

F-001087J

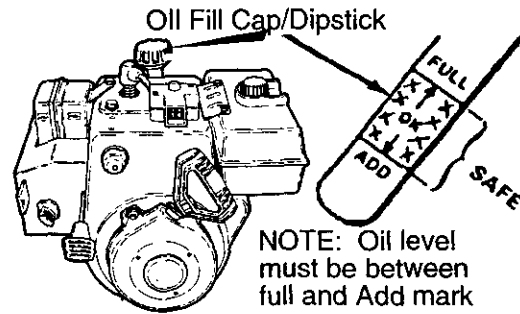

NOTE: Oil level must be between full and Add mark

Figure 14

4. Tighten the fill cap/dipstick securely each time you check the oil level.

NOTE: For extreme cold operating conditions of 0°F and below, use a partial synthetic 0W30 motor oil for easier starting.

NOTE: S.A.E. 5W30 motor oil may be used to make starting easier in areas where temperature is consistently 20°F or lower.

FILL GAS:

NOTICE: ENGINES WHICH ARE CERTIFIED TO COMPLY WITH CALIFORNIA AND US EPA EMISSION REGULATIONS FOR ULGE ENGINES: Are certified to operate on regular unleaded gasoline. Include the following emission control system(s): EM, TWC (if so equipped). Include any user adjustable features—therefore no other adjustments are needed.



WARNING: Experiences indicates that alcohol blended fuels (called gasohol or those using ethanol or methanol) can attract moisture which leads to separation and formation of acids during storage. Acidic gas can damage the fuel system of an engine while in storage.

NOTE: To avoid engine problems, the fuel system must be emptied before storage for 30 days or longer. Start the engine and let it run until the fuel lines and carburetor are empty. Use the carburetor bowl drain to empty residual gasoline from the float chamber. Use fresh fuel next season. See the **Storage** section in this manual for additional information.

OPERATION

Never use engine or carburetor cleaner products in the fuel tank or permanent damage may occur.

1. Fill the fuel tank only with a fresh, clean, unleaded regular, unleaded premium, or reformulated automotive gasoline. **DO NOT** use leaded gasoline. Make sure that the container you pour the gasoline from is clean and free from rust or other foreign particles. Never use gasoline that may be stale from long periods of storage in the container.



WARNING: Gasoline is flammable. Always use caution when handling or storing

gasoline.

Do not fill fuel tank while snow thrower is running, when it is hot, or when snow thrower is in an enclosed area.

Keep away from open flame or an electrical spark and do not smoke while filling the fuel tank.

Never fill the tank completely. Fill the tank to within 1/4"–1/2" from the top to provide space for expansion of fuel.

Always fill fuel tank outdoors and use a funnel or spout to prevent spilling.

Make sure to wipe up any spilled fuel before starting the engine.

Store gasoline in a clean, approved container and keep the cap in place on the container.

TO STOP ENGINE

To stop engine, move the throttle control lever to "STOP" position and remove key. Keep the key in a safe place. The engine will not start without the key.

TO START ENGINE

(electric starter, if equipped)

Be sure that the engine has sufficient oil. The snow thrower engine is equipped with a 120 volt A.C. electric starter and recoil starter. Before start-

F-001087J

ing the engine, be certain that you have read the following information.



WARNING: The starter is equipped with a three-wire power cord and plug and is designed to operate on 120 volt AC household current. It must be properly grounded at all times to avoid the possibility of electrical shock which may be injurious to operator. Follow all instructions carefully as set forth in the "To Start Engine" section. Determine that your house wiring is a three-wire grounded system. Ask a licensed electrician if you are not sure. If your house wire system is not a three-wire system, do not use this electric starter under any conditions. If your system is grounded and a three-hole receptacle is not available at the point your starter will normally be used, one should be installed by a licensed electrician. When connecting 120 volt AC "Power Cord", always connect the cord to the Switch Box" on the engine first, then plug the other end into the three-hole grounded receptacle. When disconnecting "Power cord", always unplug the end in the three-hole grounded receptacle first.

COLD START

1. Be sure auger drive and traction drive levers are in the disengaged (RELEASED) position.
2. Move throttle control to "FAST" position.
3. Remove the keys from the plastic bag. Insert one key into ignition slot. Make sure it snaps into place. **Do not turn key.** Keep the second key in a safe place.
4. Rotate choke knob clockwise to the choke ON position.
5. Connect the power cord to the **switch box** on the engine.
6. Plug other end of power cord into a three-hole, grounded 120 VOLT, AC receptacle. (See WARNING in this section).

OPERATION

7. Push the **primer button** while covering the vent hole as follows: Remove finger from primer button between primes.
Do not prime if temperature above 50° F (10° C).
Push two time if temperature is 50° F (10° C) to 15°F (-10° C).
Push four times if temperature is below 15° F (-10° C).
8. Push down on the **starter button** until the engine starts. Do not crank for more than 10 seconds at a time. This electric starter is thermally protected. If overheated it will stop automatically and can be restarted only when it has cooled to a safe temperature (a wait of about 5 to 10 minutes is required).
9. When the engine starts, release the **starter button** and move **choke lever** to "1/2 choke" position. When engine runs smoothly, move **choke lever** to "No Choke" Position.
10. Disconnect power cord from receptacle, first, and then from **switch box**.

NOTE: Allow the engine to warm up for several minutes before blowing snow in temperatures below 0°F.

11. Run engine at full throttle "**FAST**" when throwing snow.

WARM START

If restarting a warm engine after a short shutdown, leave choke at "OFF" and do not push the primer button. If the engine fails to start, follow the Cold Start instructions.

TO START ENGINE

(recoil starter)

Be sure that the engine has sufficient oil. The snow thrower engine is equipped with a recoil starter. Before starting the engine, be certain that you have read the following information.

F-001087J

COLD START

1. Be sure auger drive and traction drive levers are in the disengaged (**RELEASED**) position.
2. Move throttle control to "**FAST**" position.
3. Remove the keys form the plastic bag. Insert one key into ignition slot. Make sure it snaps into place. **Do not turn key.** Keep the second key in a safe place.
4. Rotate choke knob clockwise to the choke ON position.
5. Push the **primer button** while covering the vent hole as follows: Remove finger from primer button between primes.
Do not prime if temperature above 50° F (10° C).
Push two time if temperature is 50° F (10° C) to 15°F (-10° C).
Push four times if temperature is below 15° F (-10° C).
6. Pull the **starter handle** rapidly. Do not allow the handle to snap back, but allow it to rewind slowly while keeping a firm hold on the **starter handle**.
7. As the engine warms up, move **choke lever** to "1/2 choke" position. When engine runs smoothly, move **choke lever** to "No Choke" Position.

NOTE: Allow the engine to warm up for several minutes before blowing snow in temperatures below 0°F.

8. Run engine at full throttle "**FAST**" when throwing snow.

WARM START

If restarting a warm engine after a short shutdown, leave choke at "**OFF**" and do not push the primer button. If the engine fails to start, follow the Cold Start instructions.

FROZEN STARTER

If the starter is frozen and will not turn engine:

1. Pull as much rope out of the starter as possible.

OPERATION

2. Release the starter handle and let it snap back against the starter.

If the engine still fails to start, repeat the two previous steps until the engine starts. Then continue with the directions for cold start.

To help prevent possible freeze-up of recoil starter and engine controls, proceed as follows after each snow removal job.

1. With the engine running, pull the starter rope hard with a continuous full arm stroke three or four times. Pulling of starter rope will produce a loud clattering sound. This is not harmful to the engine or starter.
2. With the engine not running, wipe all snow and moisture from the carburetor cover in area of control levers. Also move throttle control, choke control, and starter handle several times.



WARNING: Never run engine indoors or in enclosed, poorly ventilated areas. Engine exhaust contains CARBON MONOXIDE, AN ODORLESS AND DEADLY GAS. Keep hands, feet, hair and loose clothing away from any moving parts on engine and snow thrower.

The temperature of muffler and nearby areas may exceed 150°F. Avoid these areas.

DO NOT allow children or young teenagers to operate or be near snow thrower while it is operating.



WARNING: Do not attempt to remove any item that may become lodged in auger without taking the following precautions:

- Release auger drive lever.
- Move throttle lever to stop position.
- Remove (do not turn) ignition key.

- Disconnect spark plug wire.
- Do not place your hands in the auger or discharge chute. Use a pry bar.

SNOW THROWING TIPS

1. For maximum snow thrower efficiency in removing snow, adjust ground speed, NEVER the throttle. Go slower in deep, freezing or wet snow. If the wheels slips, reduce forward speed. The engine is designed to deliver maximum performance at full throttle and should be run at this power setting at all times.
2. Most efficient snow throwing is accomplished when the snow is removed immediately after it falls.
3. For complete snow removal, slightly overlap each path previously taken.
4. The snow should be discharged down wind whenever possible.
5. For normal usage, set the skids so that the scraper bar is 1/8" above the skids. For extremely hard-packed snow surfaces, adjust the skids upward so that the scraper bar touches the ground.
6. On gravel or crushed rock surfaces, set the skids at 1-1/4" below the scraper bar. See **To Adjust Skid Height** paragraph in the **Service & Adjustments** section of this manual. Rocks and gravel must not be picked up and thrown by the machine.
7. After the snow throwing job has been completed, allow the engine to idle for a few minutes, which will melt snow and accumulated ice off the engine.
8. Clean the snow thrower thoroughly after each use.
9. Remove ice and snow accumulation and all debris from the entire snow thrower, and flush with water (if possible) to remove all salt or other chemicals. Wipe snow thrower dry.

MAINTENANCE

CUSTOMER RESPONSIBILITIES

SERVICE RECORDS Fill in dates as you complete regular service.	Before Each Use	Often	Every 5 Hours	Every 10 Hours	Every 25 Hours	Each Season	Before Storage	SERVICE DATES
Check Engine Oil Level	√		√			√		
Change Engine Oil					√	√		
Tighten All Screws and Nuts	√	√						
Check Spark Plug					√	√		
Lubricate All Pivot Points				√			√	
Lubricate Disc Drive Plate Zerk (See Maintenance)							√	
Check Fuel	√							
Drain Fuel							√	
Check Cable Adjustment (See Cable Adjustment)						√		
Adjust Drive Belt	√				√	√		

GENERAL RECOMMENDATIONS

The warranty on this snow thrower does not cover items that have been subjected to operator abuse or negligence. To receive full value from the warranty, the operator must maintain the snow thrower as instructed in this manual.

Some adjustments will need to be made periodically to properly maintain your snow thrower.

All adjustments in the **Service and Adjustments** section of this manual should be checked at least once each season.

AFTER EACH USE

- Check for any loose or damaged parts.
- Tighten any loose fasteners.
- Check and maintain the auger.
- Check controls to make sure they are functioning properly.

- If any parts are worn or damaged, replace immediately.

LUBRICATION CHART

Lubricate Disc Drive Plate Zerk With a Hi Temp EP Moly Grease.

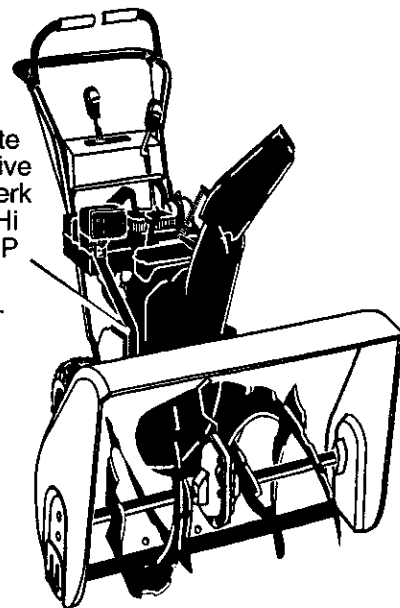

Figure 15

MAINTENANCE

PRODUCT SPECIFICATIONS

HORSEPOWER	11.0 HP
DISPLACEMENT	21.82 cu. in.
GASOLINE CAPACITY	4 quarts (unleaded)
OIL CAPACITY (20 oz capacity)	5W30
SPARK PLUG:	Champion RJ19LM (Gap .030 in.) or equivalent
VALVE CLEARANCE:	Intake: .010 in. Exhaust: .010 in.

SNOW THROWER

AS REQUIRED

The following adjustment should be performed more than once each season.

1. Auger drive belt should be adjusted after the first 2 to 4 hours of use, again about mid-season and twice each season thereafter (**See to Adjust Belts paragraph in the Service and Adjustment section**).

LUBRICATION—EVERY 25 HOURS

Lubricate Disc Drive Plate every twenty-five (25) hours and at the end of the season and/or before storage.

To Lubricate

1. Position speed selector lever in first gear.
2. Stand the snow thrower up on the auger housing end.
3. Remove the bottom panel.
4. Turn **disc drive plate** clockwise by hand until **grease zerk** is clearly visible at front center. See Figure 16.
5. Place a **coin** or (a **shim of equal thickness**) between the rubber **friction wheel** and **disc drive plate** to

prevent rubber friction wheel contacting the **drive disc plate**.

6. To **grease zerk**, use a hand grease gun, lubricate with a Hi Temp EP Moly grease. Fill zerk only until grease becomes visible below bearing assembly located under grease zerk. **DO NOT** over fill.

CAUTION: DO NOT allow grease to come in contact with the **disc drive plate** or **friction wheel** or damage will result.

IMPORTANT: Remove **coin** and ensure that a gap exists between **friction wheel** and **disc drive plate**.

NOTE: Clean all excess grease found on friction disc hub.

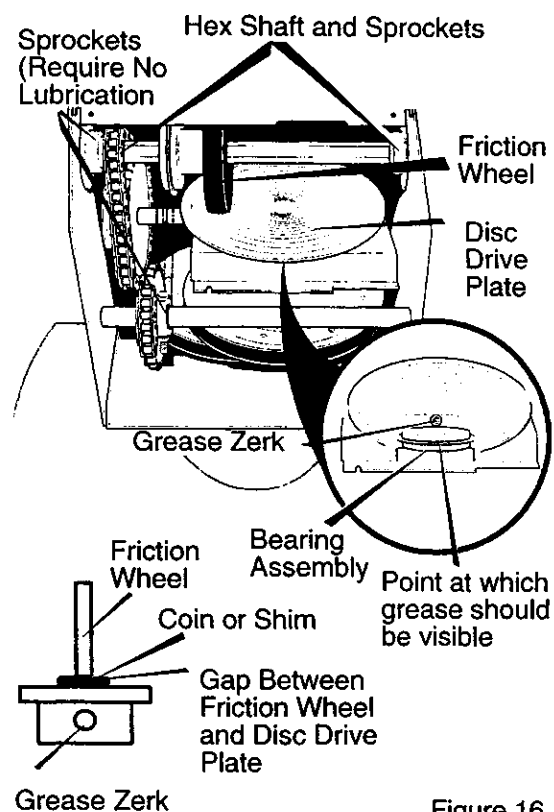

Figure 16

LUBRICATION—NOT REQUIRED

1. **Hex Shaft and Sprockets** – **Hex shaft and sprockets** require no lubrication. All bearings and bushings are lifetime lubricated and require no maintenance. See Figure 16.

NOTE: Any greasing or oiling of the above components can cause contamination of the friction wheel. If the disc

MAINTENANCE

drive plate or friction wheel come in contact with grease or oil, damage to the friction wheel will result.

Should grease or oil come in contact with the disc drive plate or friction wheel, be sure to clean the plate and wheel thoroughly.

NOTE: For storage, the hex shaft and sprockets should be wiped with 5W30 motor oil to prevent rusting.

2. **Auger Gear Box** – The auger gear box is lubricated at the factory and should not require additional lubrication. If for some reason the lubricant should leak out, have auger gear case checked by a competent repairman.

ENGINE

LUBRICATION

Check the crankcase oil level before starting the engine and after each five (5) hours of continuous use. See Figure 17. Add S.A.E. 5W30 motor oil as needed. Tighten fill cap/dipstick securely each time you check the oil level.

Oil Fill Cap/Dipstick

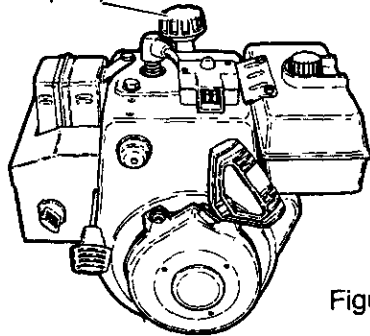

Figure 17

Change the oil every twenty-five (25) hours or at least once a year if the snow thrower is not used for twenty-five (25) hours.

TO CHANGE ENGINE OIL

1. Position the snow thrower so that the oil drain plug is at the lowest point on the engine.
 2. Remove the oil drain plug and the **oil fill cap/dipstick**. Drain the oil into a suitable container.
- NOTE:** The oil will drain more freely when the engine is warm.
3. After draining all the oil, reinstall the oil drain plug securely.
 4. Fill the engine crankcase with S.A.E. 5W30 motor oil, pouring slowly. **DO NOT OVERFILL.**

SPARK PLUG

Check the **spark plug** every twenty-five (25) hours. Replace the **spark plug** if the electrodes are pitted or burned or if the porcelain is cracked.

1. Make sure the **spark plug** is clean. Clean the **spark plug** by carefully scraping the electrodes (**do not sand blast or use a wire brush**).
2. Check the **spark plug** gap with a **feeler gauge** and reset gap to 0.30" if necessary. See Figure 18.
3. Before installing the **spark plug**, coat the threads lightly with oil for easy removal. Tighten the spark plug to a torque of 15 foot-pounds.

Feeler Gauge
0.030"

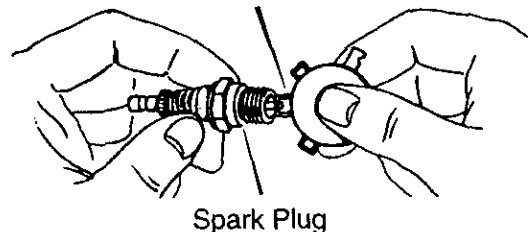



Figure 18

SERVICE AND ADJUSTMENT

 **WARNING:** Always disconnect the spark plug wire and place it where it cannot make contact with spark plug to prevent accidental starting when making any adjustments or repairs.

TO ADJUST SKID HEIGHT

This snow thrower is equipped with two height adjustment skids, located on the outside of the auger housing. See Figure 19.

These skids elevate the front of the snow thrower.

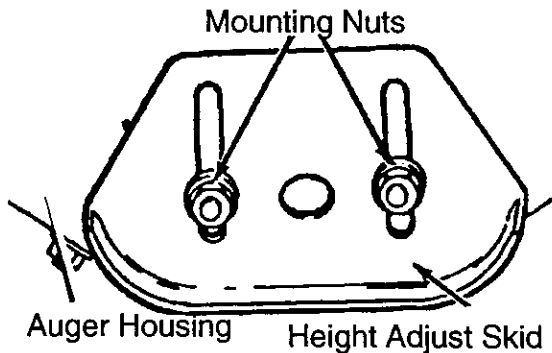



Figure 19

For normal hard surfaces, such as a paved driveway or walk, adjust the skids as follows.

1. Position the snow thrower on a level surface.
2. Make sure both tires are equally inflated. Proper tire pressure is 14 to 17 PSI. See side of tire for maximum inflation. Do not exceed sidewall maximum pressure on tire.
3. Place the extra shear bolts supplied (**found in parts bag**) under each end of the scraper bar next to the adjustable skids.
4. Loosen the mounting nuts that hold the adjustable skids. To bring the front of the snow thrower down,

raise the adjustable skids. Tighten the mounting nuts. See Figure 19.

NOTE: For rocky or uneven surfaces, raise the front of the snow thrower by moving the skids down.

 **WARNING:** Be certain to maintain proper ground clearance for your particular area to be cleared. Objects such as gravel, rocks or other debris, if struck by the impeller, may be thrown with sufficient force to cause personal injury, property damage or damage to the snow thrower.

TO ADJUST SCRAPER BAR

After considerable use, the metal scraper bar will have a definite wear pattern. The scraper bar in conjunction with the skids should always be adjusted to allow 1/8" between the scraper bar and the sidewalk or area to be cleaned.

1. Position the snow thrower on a level surface.
2. Make sure both tires are equally inflated. Proper tire pressure is 14 to 17 PSI. See side of tire for maximum inflation. Do not exceed sidewall maximum pressure on tire.
3. Loosen the carriage bolts and nuts securing the scraper bar to the auger housing.
4. Adjust the scraper bar to the proper position.
5. Tighten the carriage bolts and nuts, making sure that the scraper bar is parallel with the working surface.
6. For extended operation, the scraper bar may be reversed. If the scraper bar must be replaced due to wear, remove the carriage bolts and nuts and install a new scraper bar.

SERVICE AND ADJUSTMENT

HOW TO CHECK AND ADJUST THE CABLES

The cables are adjusted at the factory and no adjustment should be necessary. If the cables have become stretched or are sagging adjustment will be necessary.

To check for correct adjustment, disconnect the **Z-fitting** at the **drive lever**, move the **drive lever** to the full forward position, just contacting the **plastic bumper**. The control cables are correctly adjusted when the center of the "**Z**" fitting is between the center and top of the hole in the **drive lever** and there is no droop in the cable. See Figure 20.

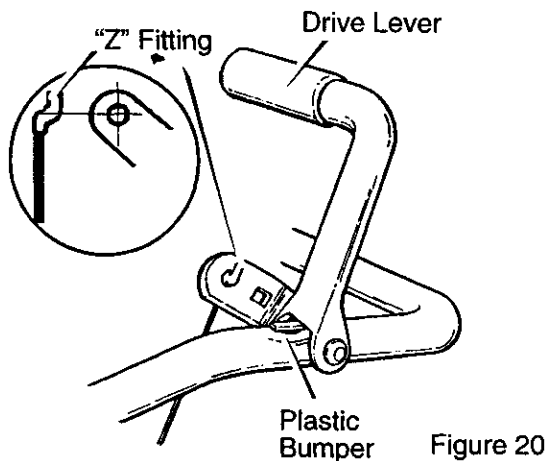

1. Remove gas from gas tank. Stand snow thrower on end.
2. Disconnect the "**Z**" fitting from drive lever.
3. Pull spring cover up to expose **spring**. Push the cable through the **spring** to expose the threaded portion of the cable. See Figure 21.
4. Hold the **square end** of the threaded portion with pliers and adjust the **locknut** in or out until the excess slack is removed.

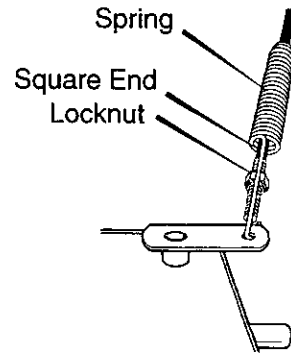

Figure 21

5. Pull the cable back through the **spring** and connect the cable. Do the same for the other drive lever cable, if needed.

NOTE: Whenever the traction drive or auger belts are adjusted or replaced, the cables will need to be adjusted.

TO ADJUST BELTS

Belts stretch during normal use. If you need to adjust the belts due to wear or stretch, proceed as follows:

How To Adjust The Auger Drive Belt

If your snow thrower will not discharge snow, check the control cable adjustment. If it is correct, then check the condition of the auger drive belt. It may be loose or damaged. If it is damaged, replace it. See **To Replace Belts** paragraph in this section. If the auger drive belt is loose, adjust as follows:

1. Disconnect the spark plug wire.
2. Remove the **belt cover**. See Figure 22.

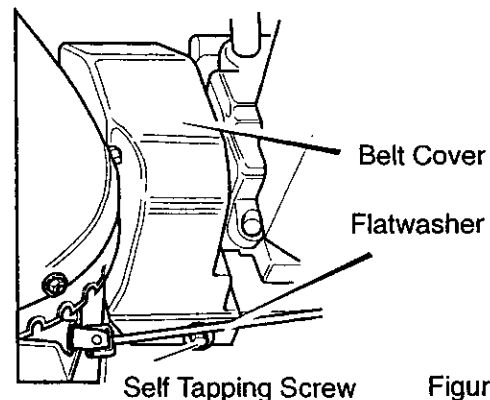

Figure 22

SERVICE AND ADJUSTMENT

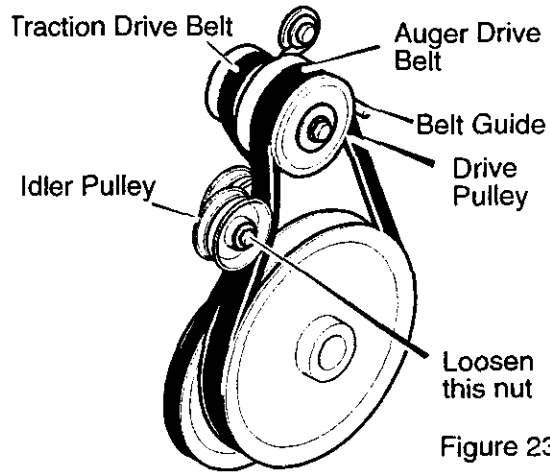

Figure 23

- Loosen the **nut** on the **idler pulley** and move the pulley toward the belt about 1/8". See Figure 23.
- Tighten the **nut**.
- Press the auger drive lever. Check the tension on the belt (opposite **auger idler pulley**). The belt should deflect about 1/2" with moderate pressure (See Figure 24).

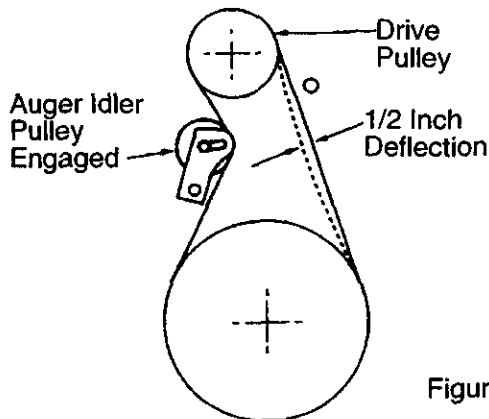

Figure 24

NOTE: If the adjustment is not correct, repeat the adjustment.

- Replace the belt cover.
- Check the clutch control cable adjustment.
- Reconnect the spark plug wire.

Traction Drive Belt

The traction drive belt has constant spring pressure and does not require adjustment. Replace the traction drive belt if it is slipping. See **To Replace Belts** paragraph in this section.

F-001087J

TO REPLACE BELTS

The drive belts on this snow thrower are of special construction and should be replaced with original equipment belts available from your nearest Craftsman Store. A distributor's list is supplied in the parts manual.

You will need the assistance of a second person while replacing the belts.

How To Remove The Auger Drive Belt

If the auger drive belt is damaged, the snow thrower will not discharge snow. Replace the damaged belt as follows.

- Remove the gas from the gas tank. Stand the snow thrower up on the front end of the auger housing.



WARNING: Drain the gasoline outdoors, away from fire or flame.

- Disconnect the spark plug wire.
- Remove the **screw** from the **belt cover**. Remove the **belt cover**. See Figure 22.
- Remove the **bolts** on each side of the **motor mount frame**. See Figure 25.
- Loosen the **bolts** on each side of the **motor mount frame**. The **auger housing** and the **motor mount frame** will separate, hinged by the **bolts**.

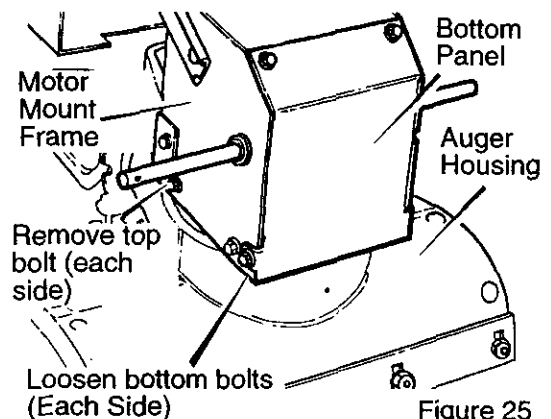

Figure 25

- Loosen the **belt guide**. Pull the **belt guide** away from the **auger drive pulley**. See Figure 23.
- Loosen the **nut** on the **idler pulley**. Pull the **idler pulley** away from the **auger drive belt**.

SERVICE AND ADJUSTMENT

8. Remove the old **auger drive belt**. Replace the **auger drive belt** with an original factory replacement belt available from an authorized service center.
9. Install the new **auger drive belt** onto the **auger drive pulley** and onto the **drive pulley**.
10. Adjust the **auger drive belt**. See "How To Adjust The Auger Drive Belt" in the Service And Adjustment section.
11. Adjust the **belt guide**. See "How To Adjust The Belt Guide" in the Service And Adjustment section.
12. Install the **bolts** on each side of the **motor mount frame**. See Figure 25.
13. Tighten the **bolts** on each side of the **motor mount frame**.
14. Install the **belt cover**. Tighten the **screw**. See Figure 22.
15. Check the adjustment of the cables. See "How To Check And Adjust The Cables" in the Service And Adjustment section.
16. Connect the spark plug wire.

How To Remove the Traction Drive Belt

If the snow thrower will not move forward, check the traction drive belt for wear or damage. If the traction drive belt is worn or damaged, replace the belt as follows.

1. Remove the gas from the gas tank. Stand the snow thrower up on the front end of the auger housing.



WARNING: Drain the gasoline outdoors, away from fire or flame.

2. Disconnect the spark plug wire.
3. Remove the auger drive belt. See "How To Remove The Auger Drive Belt" in the Maintenance section.

F-001087J

4. Pull the traction drive idler pulley away from the traction drive belt. See Figure 26.

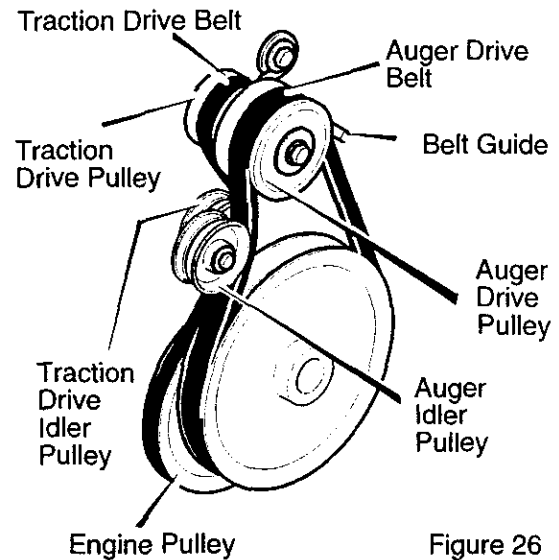

5. Remove the old traction drive belt from the traction drive pulley and from the engine pulley. Replace the traction drive belt with an original factory replacement belt available from an authorized service center.
6. Install the new traction drive belt onto the traction drive pulley and onto the engine pulley.
7. Make sure the traction drive idler pulley is properly aligned with the traction drive belt.
8. Install and adjust the auger drive belt. See "How To Remove The Auger Drive Belt" in the Service And Adjustment section.
9. Adjust the belt guide. See "How To Adjust The Belt Guide" in the Service And Adjustment section.
10. Install the bolts on each side of the motor mount frame. See Figure 25.
11. Tighten the bolts on each side of the motor mount frame.
12. Install the belt cover. Tighten screw. See Figure 22.
13. Check the adjustment of the cables. See "How To Check And Adjust The Cables" in the Service And Adjustment section.
14. Connect the spark plug wire.

SERVICE AND ADJUSTMENT

HOW TO ADJUST THE BELT GUIDE

1. Disconnect spark plug wire.
2. Remove the **screw**. Remove the **belt cover**. See Figure 22.
3. Engage the **auger drive lever**.
4. Measure the distance between the **belt guide** and **auger drive belt**. The **correct distance** is 1/8 inch (3.175 mm). See Figure 27.

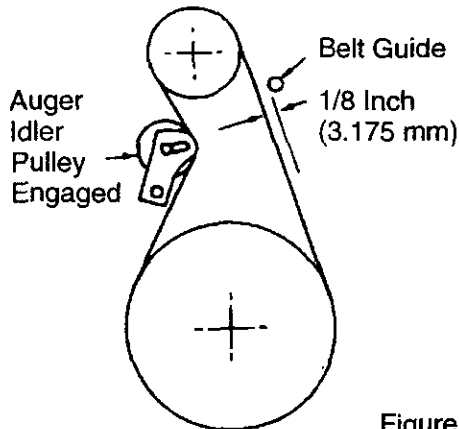

Figure 27

5. If an adjustment is necessary, loosen the mounting bolt for the **belt guide**. Move the **belt guide** to the **correct position**. Tighten the mounting bolt for the **belt guide**.
6. Install the **belt cover**. Tighten the **screw**. See Figure 22.
7. Connect the spark plug wire.

HOW TO ADJUST OR REPLACE THE FRICTION WHEEL

How To Check The Friction Wheel

If the snow thrower will not move forward, check the traction drive belt, the traction drive cable or the friction wheel. If the friction wheel is worn or damaged, it must be replaced. See "How To Replace the Friction Wheel" in this section. If the friction wheel is not worn or damaged, check as follows.

1. Remove the gas from the gas tank. Stand the snow thrower up on the front end of the auger housing.

F-001087J



WARNING: Drain the gasoline outdoors, away from fire or flame.

2. Disconnect the spark plug wire.
3. Remove the **bolts** on each side of the **bottom panel**. See Figure 28.
4. Loosen the **bolts** on each side of the **bottom panel**.
5. Remove the **bottom panel**.

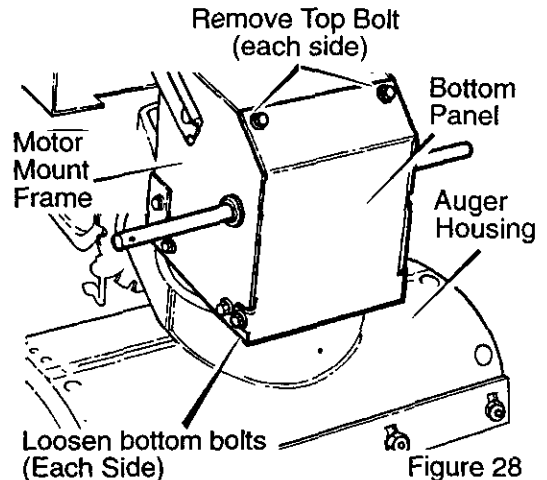

Figure 28

6. Position the **shift speed lever** in the first forward gear.
7. Note the position of the **friction wheel** on the **disc drive plate** (See Figure 29). In the correct position, the right outer side of the **disc drive plate** must be three inches (7.62cm.) from the center of the **friction wheel**. If the **friction wheel** is not in the correct position, adjust as follows.

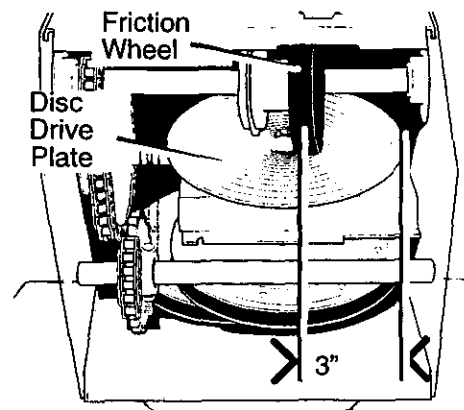

Figure 29

How To Adjust The Friction Wheel

1. Loosen the bolts on the **speed control rod** to obtain the correct

SERVICE AND ADJUSTMENT

position for the friction wheel. See Figure 30.

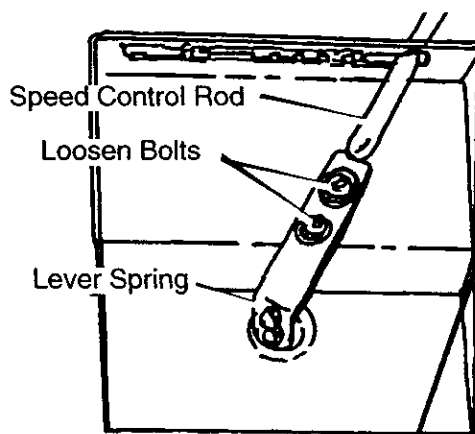

Figure 30

2. Install the **bottom panel**. See Figure 28.
3. Tighten the **bolts** on each side of the **bottom panel**.
4. Install the **bolts** on each side of the **bottom panel**.

How To Replace The Friction Wheel

If the friction wheel is worn or damaged, the snow thrower will not move forward. The friction wheel must be replaced as follows.

1. Remove the gas from the gas tank. Stand the snow thrower up on the front end of the auger housing.



WARNING: Drain the gasoline outdoors, away from fire or flame.

2. Disconnect the spark plug wire.
3. Remove the **top bolts** on each side of the **bottom panel**. See Figure 28.
4. Loosen the **bottom bolts** on each side of the **bottom panel**.
5. Remove the **bottom panel**.
6. Remove the three fasteners that hold the **friction wheel** to the **hub**. See Figure 31.

F-001087J

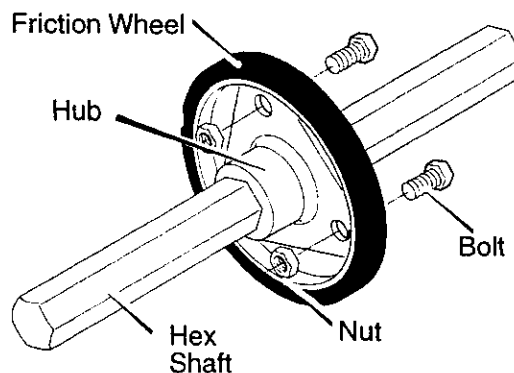

Figure 31

7. Remove the four bolts that hold the **bearing plates** on each side of the **hex shaft**. See Figure 32.

NOTE: Take special note of the position of the washers and retaining ring on the hex shaft and the sprocket assembly.

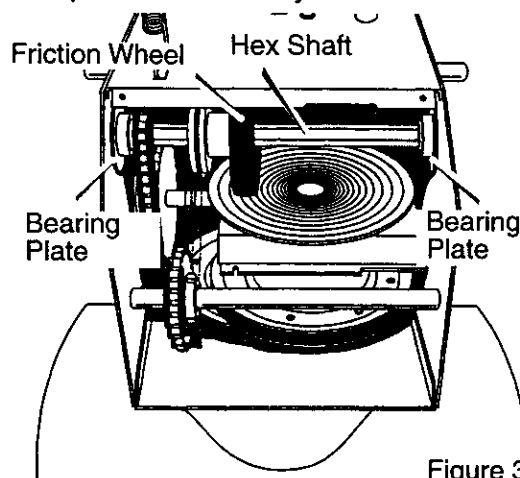

Figure 32

8. Remove the **bearing plate** from the right side. Do not remove the **hex shaft**. Leave the **hex shaft** in position. Carefully raise **hex shaft** just enough to allow the **friction wheel** to be removed.
9. Remove the **friction wheel** from the **hub**. Slip the **friction wheel** toward the right off the **hex shaft**. See Figure 31.
10. Assemble the new **friction wheel** onto **hub** with the fasteners removed earlier.
11. Install the **bearing plate** onto the right side. Make sure the **hex shaft** is engaged with both **bearing plates** and that the washers and retaining ring are installed in the original position. See Figure 32.

SERVICE AND ADJUSTMENT

12. Fasten the **bearing plates** using the four bolts removed earlier.
13. Make sure the **hex shaft** turns freely.
14. Check the adjustment of the friction wheel. See "How To Adjust The Friction Wheel" in this section.
15. Make sure the friction wheel and the disc drive plate are free from grease or oil.
16. Install the **bottom panel**. See Figure 28.
17. Tighten the **bottom bolts** on each side of the **bottom panel**.
18. Install the **top bolts** on each side of the **bottom panel**.
19. Connect the spark plug wire.

HOW TO REPLACE THE AUGER SHEAR BOLT

The augers are secured to the auger shaft with special shear bolts. These shear bolts are designed to break and protect the machine if an object becomes lodged in the auger housing. Do not use a harder bolt as the protection provided by the shear bolt will be lost.



WARNING: For safety and to protect the machine, use only original equipment shear bolts.

To replace a broken shear bolt, proceed as follows. Extra shear bolts were provided in the assembly parts bag.

1. Move the throttle control to the stop position. Disengage all controls.
2. Disconnect the spark plug wire. Make sure all moving parts have stopped.
3. Align the hole in the auger with the hole in the auger shaft. Install the new **shear pin** and **spacer**. See Figure 33.
4. Connect the spark plug wire.

F-001087J

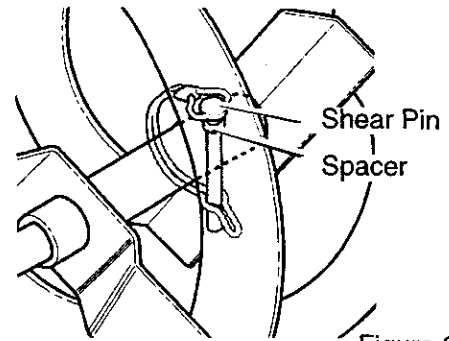

Figure 33

TO ADJUST THE CARBURETOR

If you think your carburetor needs adjusting, see your nearest Craftsman Store. Engine performance should not be affected at altitudes up to 7,000 feet. For operation at higher elevations, contact your nearest Craftsman Store.

IMPORTANT: Never tamper with the engine governor, which is factory set for proper engine speed. Over-speeding the engine above the factory high speed setting can be dangerous. If you think the engine-governed high speed needs adjusting, contact your nearest Craftsman Store, which has the proper equipment and experience to make any necessary adjustments.

TO ADJUST OR REPLACE THE SPARK PLUG

NOTE: This spark ignition system meets all requirements of the Canadian Interference-Causing Equipment Regulations.

NOTE: This engine complies with all current Australian and New Zealand limitations regarding electromagnetic interference.

If you have difficulty starting the snow thrower, adjust or replace the spark plug. Replace the spark plug if the electrodes are pitted or burned or if the porcelain is cracked. Follow the instructions below.

To adjust:

1. Clean **spark plug** by carefully scraping the electrodes (**Do not sand blast or use a wire brush**).

SERVICE AND ADJUSTMENT

2. Be sure **spark plug** is clean and free of foreign material. Check electrodes gap with a wire **feeler gauge** and reset gap to 0.030" if necessary. See Figure 34.

To Replace:

1. If you need a new spark plug, use only the proper replacement spark plug.
2. Set the gap to 0.030 inches.
3. Before installing the spark plug, lightly coat the spark plug threads with oil or grease to insure easy removal.

4. Firmly tighten the spark plug in the engine.
5. If a torque wrench is available, torque the plug to 18 to 23 foot pounds.

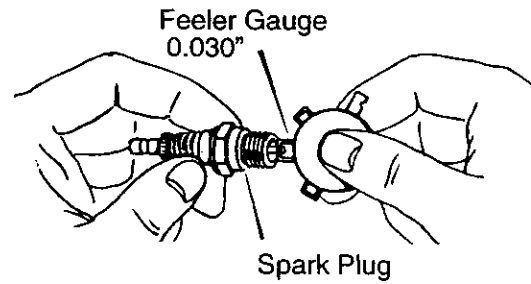

Figure 34

STORAGE



WARNING: Never store your snow thrower indoors or in an enclosed, poorly ventilated area. If gasoline remains in the tank, fumes may reach an open flame, spark or pilot light from a furnace, water heater, clothes dryer, cigarette, etc.

NOTE: To prevent engine damage (if snow thrower is not used for more than 30 days) follow the steps below.

SNOW THROWER

1. Thoroughly clean the snow thrower.
2. Lubricate all lubrication points. See the **Maintenance** section.
3. Be sure that all nuts, bolts and screws are securely fastened. Inspect all visible moving parts for damage, breakage and wear. Replace if necessary.
4. Touch up all rusted or chipped paint surfaces; sand lightly before painting.
5. Cover the bare metal parts of the blower housing auger and the impeller with rust preventative, such as a spray lubricant.

NOTE: A yearly checkup or tune-up by a Sears service center is a good way of ensuring that your snow thrower will provide maximum performance for the next season.

ENGINE



WARNING: Drain the gasoline outdoors, away from fire or flame.

Gasoline must be removed or treated to prevent gum deposits from forming in the fuel tank, filter, hose, and carburetor during storage. Also, during storage alcohol blended gasoline that uses ethanol or methanol (sometimes called gasohol) attracts water. It acts on the gasoline to form acids which damage the engine.

F-001087J

1. To remove gasoline, run the engine until the fuel tank is empty and the engine stops.
2. If you do not remove the gasoline, use fuel stabilizer supplied with unit or purchase Craftsman Fuel Stabilizer No. 3550. Add fuel stabilizer to any gasoline left in the tank to minimize gum deposits and acids. If the fuel tank is almost empty, mix stabilizer with fresh gasoline in a separate container and add some to the fuel tank.
3. Always follow the instruction on the stabilizer container. After the stabilizer is added to the fuel tank, run the engine at least ten minutes to allow the mixture to reach the carburetor.
4. Change the engine oil.
5. Lubricate the piston/cylinder area. First, remove the spark plug and squirt a few drops of clean engine oil into the spark plug hole. Next, cover the spark plug hole with a rag to absorb oil spray. Then, pull two or three times on the recoil starter rope to rotate the engine. Finally, install the spark plug and attach the spark plug wire.

OTHER

1. If possible, store your snow thrower indoors and cover it to give protection from dust and dirt.
2. If the machine must be stored outdoors, block up the snow thrower to be sure the entire machine is off the ground.
3. Cover the snow thrower with a suitable protective cover that does not retain moisture. Do not use plastic.

IMPORTANT: Never cover snow thrower while engine and exhaust areas are still warm.

TROUBLE SHOOTING

TROUBLE	CAUSE	CORRECTION
Difficult starting	Defective spark plug.	Replace spark plug.
	Water or dirt in fuel system.	Use carburetor bowl drain to flush and refill with fresh fuel.
Engine runs erratic	Blocked fuel line, empty gas tank, or stale gasoline	Clean fuel line; check fuel supply; add fresh gasoline
Engine stalls	Unit running on CHOKE.	Set choke lever to RUN position.
Engine runs erratic; Loss of power	Water or dirt in fuel system.	Use carburetor bowl drain to flush and refill with fresh fuel.
Excessive vibration	Loose parts: damaged impeller	Stop engine immediately and disconnect spark plug wire. Tighten all bolts and make all necessary repairs. If vibration continues, have the unit serviced by a Craftsman service repairman.
Unit fails to propel itself	Drive belt loose or damaged.	Replace drive belt.
	Incorrect adjustment of traction drive cable	Adjust traction drive cable.
	Worn or damaged friction wheel.	Replace friction wheel.
Unit fails to discharge snow	Auger drive belt loose or damaged.	Adjust auger drive belt; replace if damaged.
	Auger control cable not adjusted correctly.	Adjust auger control cable.
	Shear bolt broken	Replace shear bolt
	Discharge chute clogged.	Stop engine immediately and disconnect spark plug wire. Clean discharge chute and inside of auger housing.
	Foreign object lodged in auger	Stop engine immediately and disconnect spark plug wire. Remove object from auger.

CRAFTSMAN 24" 5HP SNOW THROWER 536.886440

FRAME ASSEMBLY

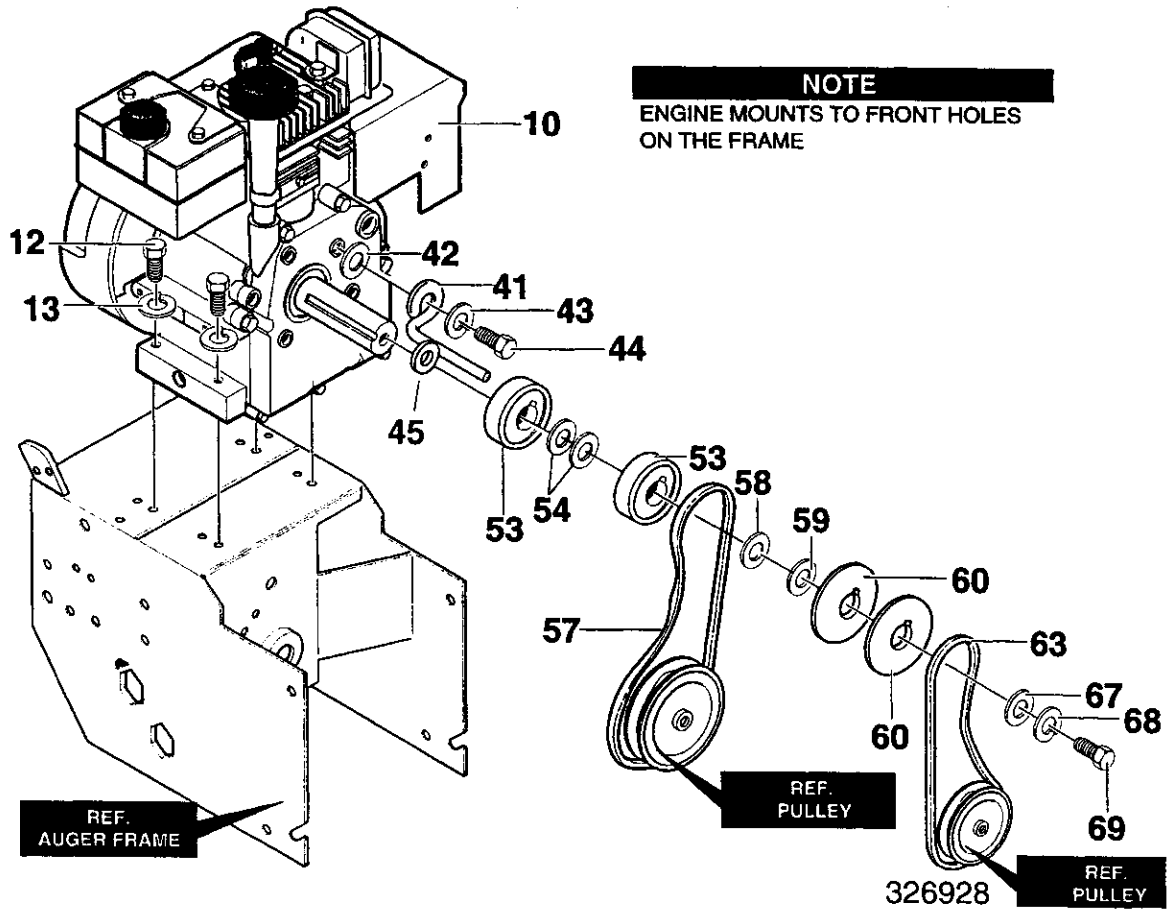

Key No.	Description	Part No.
10	Model 143.015005	ENGINE
12	SCREW, 5/16-18	710024
13	WASHER, SPTLK .31X.58X.08	71060
41	GUIDE, ROD BELT	3949
42	PLASTIC WASHER	6711
43	WASHER, SPTLK .31X.58X.08	71060
44	SCREW, 5/16-24X 1.00	910828
45	SPACER	762291
53	PULLEY, HALF	579854
54	WASHER, FLAT .752X.91X.02	579861
57	BELT, V 3L 33.13LG	579932
58	FLATWASHER .765X1.12X.06	712120
59	SPACER, SLEEVE	586251
60	PULLEY, ENGINE	586253
63	BELT, V 4L35.6 LG	581264
67	WASHER, FLAT .375X1.25X.104	50677
68	WASHER, HVSP TLK .38ID	71063
69	SCREW, 3/8-24X1.00	71015
—	OWNER'S MANUAL	F-001087J

CRAFTSMAN 24" 5HP SNOW THROWER 536.886440

ELECTRIC START ASSEMBLY

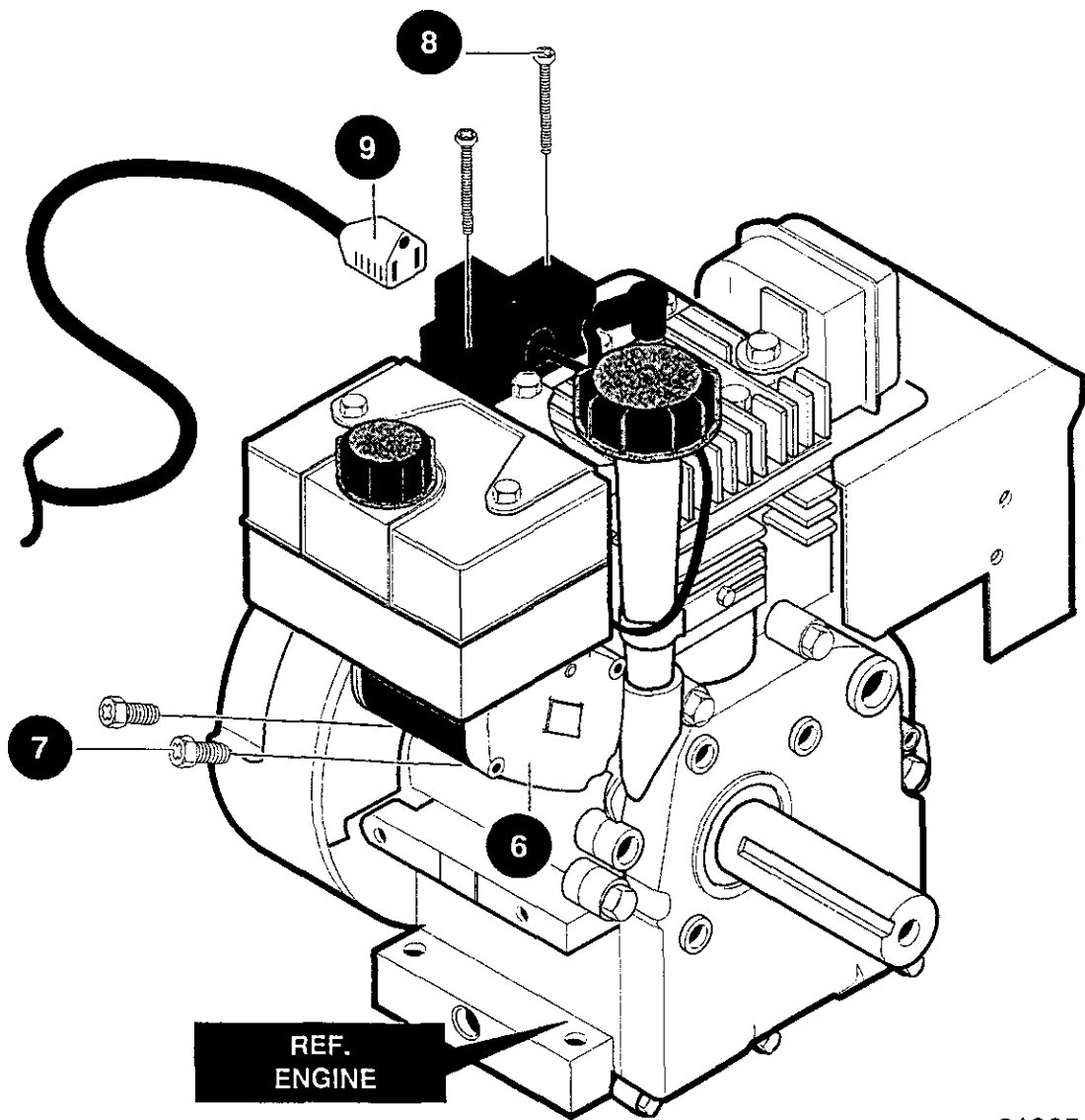

319051

Key No.	Description	Part No.
6	MOTOR, STARTER	330783
7	SCREW	762226
8	SCREW	6217
9	CORD, STARTER	6219

CRAFTSMAN 24" 5HP SNOW THROWER 536.886440

FRAME ASSEMBLY

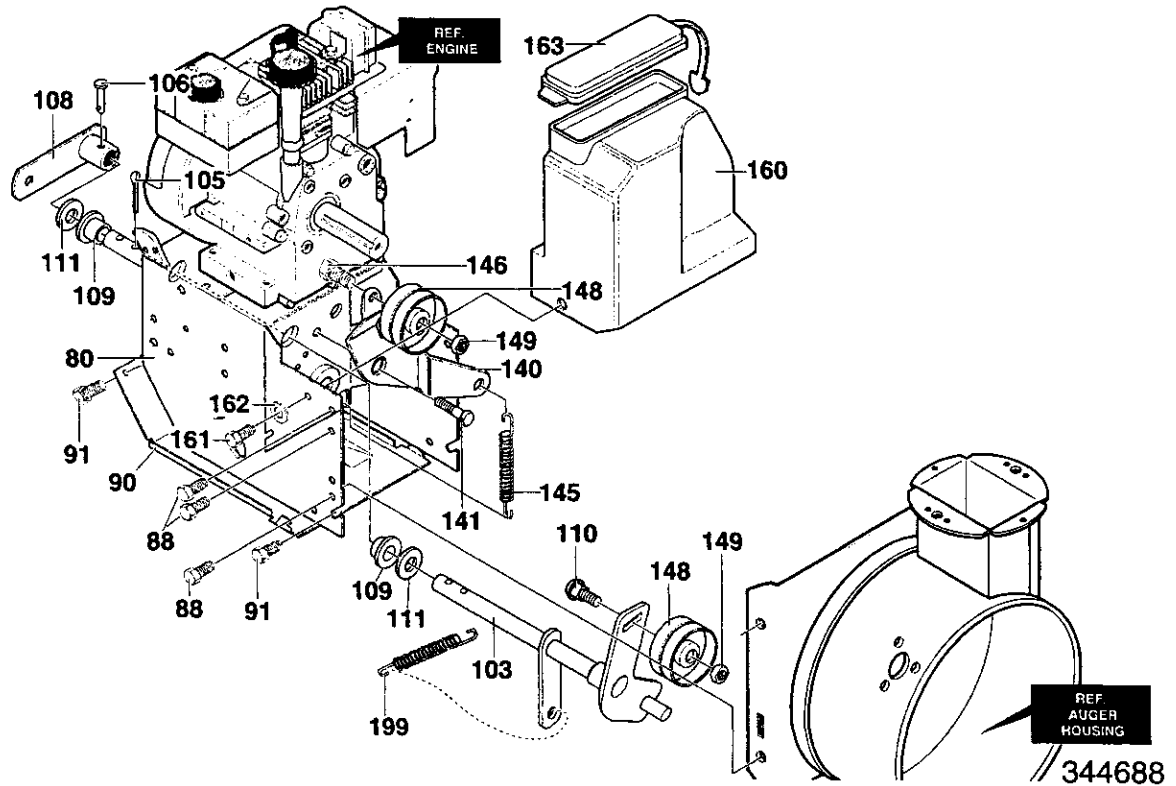

Key No.	Description	Part No.
80	FRAME ASSY	761702-833
88	SCREW, 5/16-18X .50	780055
90	COVER, BOTTOM	583031-853
91	SCREW, 1/4-20X .63	310169
103	IDLER ASSEMBLY	762295
105	PIN, HAIR .38DIA X 1.64LG	711682
106	PIN, KLIK 3/16" DIA	761761
108	ASSY., SPRING ATTACH	761766
109	BEARING, FL.	53703
110	BOLT, 3/8-16X 1.25 CARR.	585781
111	WASHER, FLAT	711617
140	LEVER, IDLER ARM TRACTION	761701
141	BOLT, .625X.135 HSH 5/16-18	329989
145	IDLER SPRING TRACTION DRIVE	53704
146	SCREW, 3/8-16X 1.25	761760
148	PULLEY, IDLER	50793
149	NUT, 3/8-16	590
160	COVER, BELT	760478
161	SCREW, 1/4-20X .63	310169
162	WASHER, FLAT	71067
163	LID, BELT COVER	760539
199	SPRING, IDLER AUGER DRIVE	760988

CRAFTSMAN 24" 5HP SNOW THROWER 536.886440

GEAR CASE ASSEMBLY

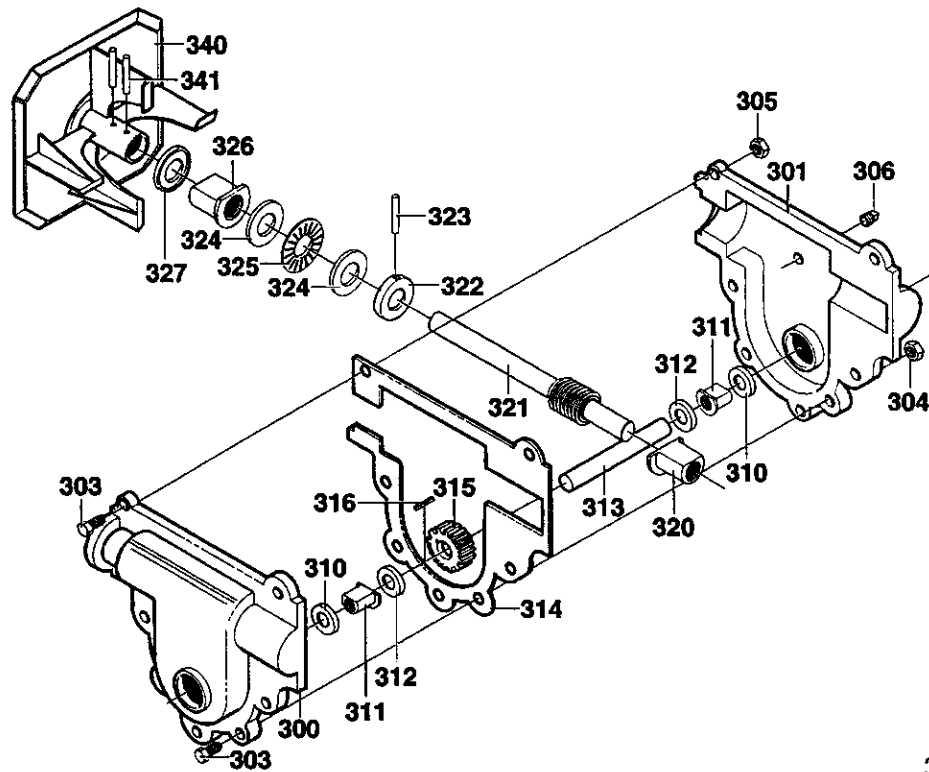

313996

Key No.	Description	Part No.
300	CASE, GEAR, RH	10577
301	CASE, GEAR, LH	10576
303	SCREW, 1/4-20X.75	710025
304	NUT, 1/4-20	302635
305	NUT, 1/4-20 HEXKEPS	303008
306	SCREW, 3/8-16X.50	9344
310	SEAL, OIL	9566
311	BEARING, FL	50304
312	WASHER, FLAT	48275
313	SHAFT, AUGER OUTPUT	340286
314	GASKET, GEAR BOX	51279
315	WORM GEAR	51405
316	KEY, WOODRUFF #61	431787
320	BRNG, FL	50221
321	SHAFT, AUGER INPUT	583125
322	COLLAR, THRUST	580295
323	PIN, SPRING	454565
324	WASHER, FLAT	48275
325	BRNG, ROLL	50684
326	BRNG, FL	50304
327	SEAL, OIL	9566
340	IMPELLER	760194-853
341	PIN, SPRING	454565
—	10oz TUBE LUBRIPLATE	333431

CRAFTSMAN 24" 5HP SNOW THROWER 536.886440

DRIVE COMPONENTS

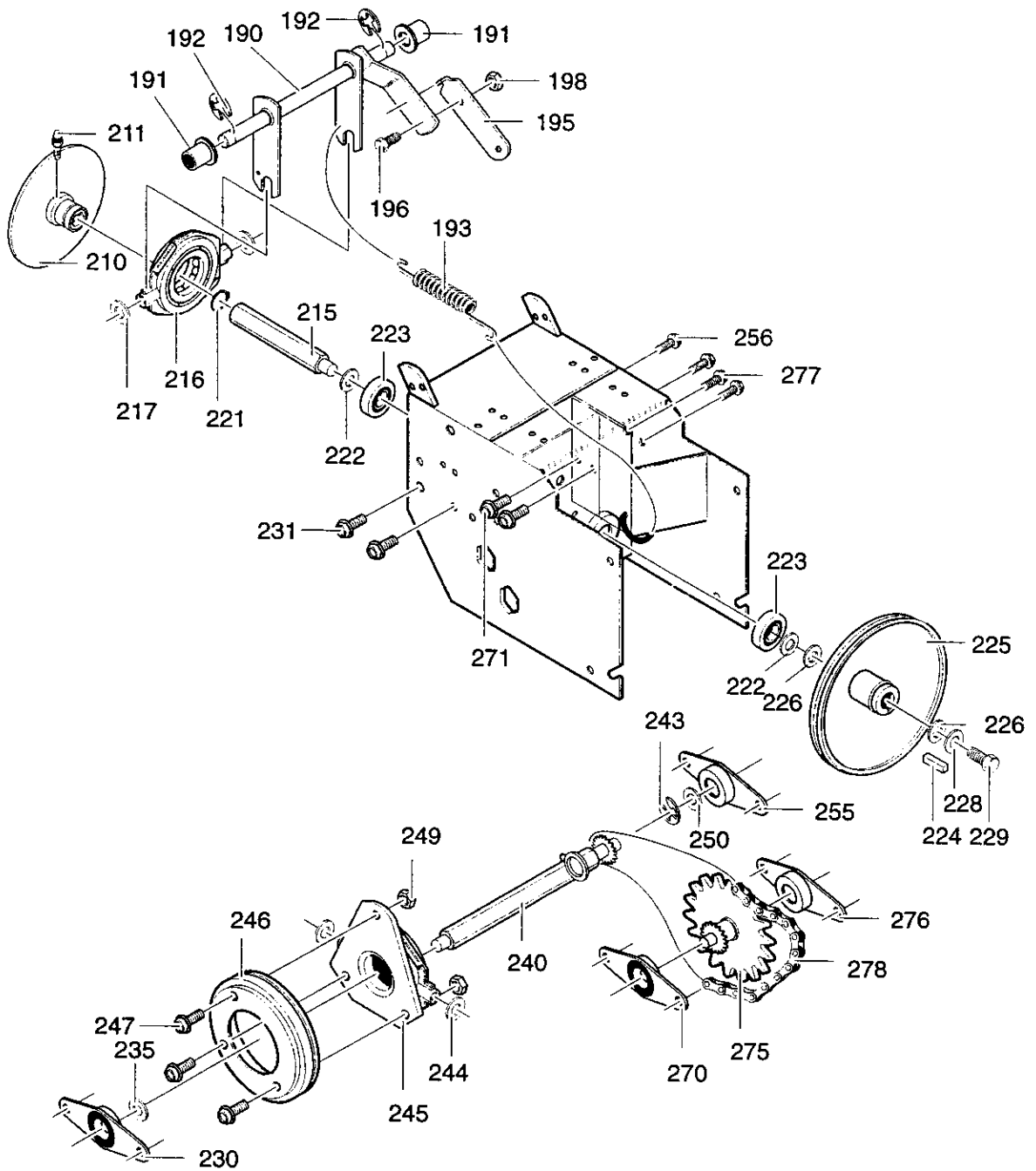

313995 REV P

CRAFTSMAN 24" 5HP SNOW THROWER 536.886440

DRIVE COMPONENTS

Key No.	Description	Part No.
190	LEVER, ASSY TRACTION CLUTCH	761820
191	BEARING, FLANGE	53703
192	RING, RET E	20864
193	SPRING, RETURN	53818
195	LEVER, SPRING	579937
196	SCREW, 1/4-20X .63	11871
198	NUT, 1/4-20 REGHEXCTRLK	73826
210	DISC, ASSY	583163-853
211	ZERK, GREASE	583206
215	SHAFT, HEX TRACTION	583155
216	BEARING, TRUNION	85501
217	FLATWASHER, .53 X1.00X.063	71074
221	RING, RETEX	73811
222	FLATWASHER, .680X1.12X.060	580969
223	BEARING, BALL	43846
224	KEY, SQUARE	71371
225	PULLEY, V3L 6.50X .56	580961
226	WASHER, WAVE	580965
227	FLATWASHER, .281X1.00X.063	712123
228	WASHER, SPLIT .26X.50X.06	71059
229	SCREW, 1/4-20X .75 HHC	1x176
230	BEARING & RETAINER	334163
231	SCREW, 5/16-18X .50	780055
235	WASHER,.502X .75X.0605	579858
240	HEX, ASSY#40-8T W/PBRG	579897
243	RING, RETEX	783002
244	FLATWASHER, .53 X1.00X.063	71074
245	BEARING, TRUNION	337029
246	WHEEL, ASSY FRICTION	53830
247	SCREW, 1/4-20X .63	11871
249	NUT, 1/4-20 HEXKEPS	303008
250	WASHER,.502X .75X.0605	579858
255	BEARING & RETAINER	334163
256	SCREW, 5/16-18X .50	780055
270	BEARING & RETAINER	334163
271	SCREW, 5/16-18X .50	780055
275	JACK, ASSY#41-36/8T	761691
276	BEARING & RETAINER	334163
277	SCREW	780055
278	CHAIN ROLLER	579867
—	LINK, CHAIN MASTER	760504

CRAFTSMAN 24" 5HP SNOW THROWER 536.886440

AUGER HOUSING ASSEMBLY

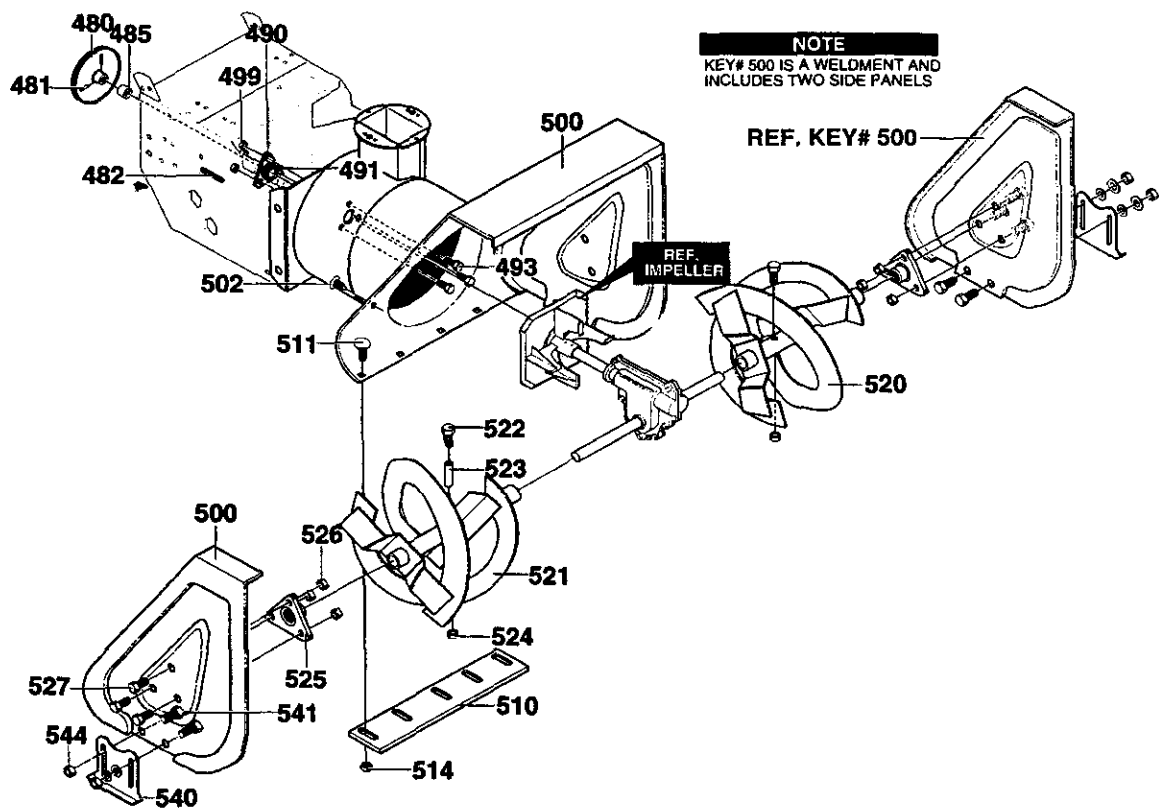

339972

**CRAFTSMAN 24" 5HP SNOW THROWER 536.886440
AUGER HOUSING ASSEMBLY**

Key No.	Description	Part No.
480	PULLEY, 4L 6.12X .67	762146
481	SCREW, 5/16-18X.63	577400
482	KEY, SQUARE	71371
485	SPACER, SLEEVE .676X1.00X.53	334514
490	RETAINER, BALL BRNG	582960
491	BEARING, BALL	43846
493	SCREW, 5/16-18X .75	313676
499	NUT, 5/16-18 HEXWDFLLK	710026
500	HOUSING, ASSY	761743-848
502	FASTENER, RATCHET	309235
510	BLADE, SCRAPER 22"	581397-853
511	BOLT, 1/4-20X.75	340714
514	NUT, 1/4-20	780285
520	AUGER, ASSY, LH	340518-853
521	AUGER, ASSY, RH	340523-853
522	SCREW, 1/4-20X1.75	*
523	SPACER, SLEEVE	3943
524	NUT, 1/4-20 REGHEXCTRLK	*
525	BEARING, FLANGE	9517
526	NUT, 5/16-18	711862
527	SCREW, 5/16-18X .75	9357
540	SKID, HEIGHT ADJUST	301380-853
541	BOLT, 5/16-18 X .75	340720
544	NUT, 5/16-18 REGHEX	710026

* When ordering replacement parts, order Shear Pin part number 760875.

CRAFTSMAN 24" 5HP SNOW THROWER 536.886440 DISCHARGE CHUTE ASSEMBLY

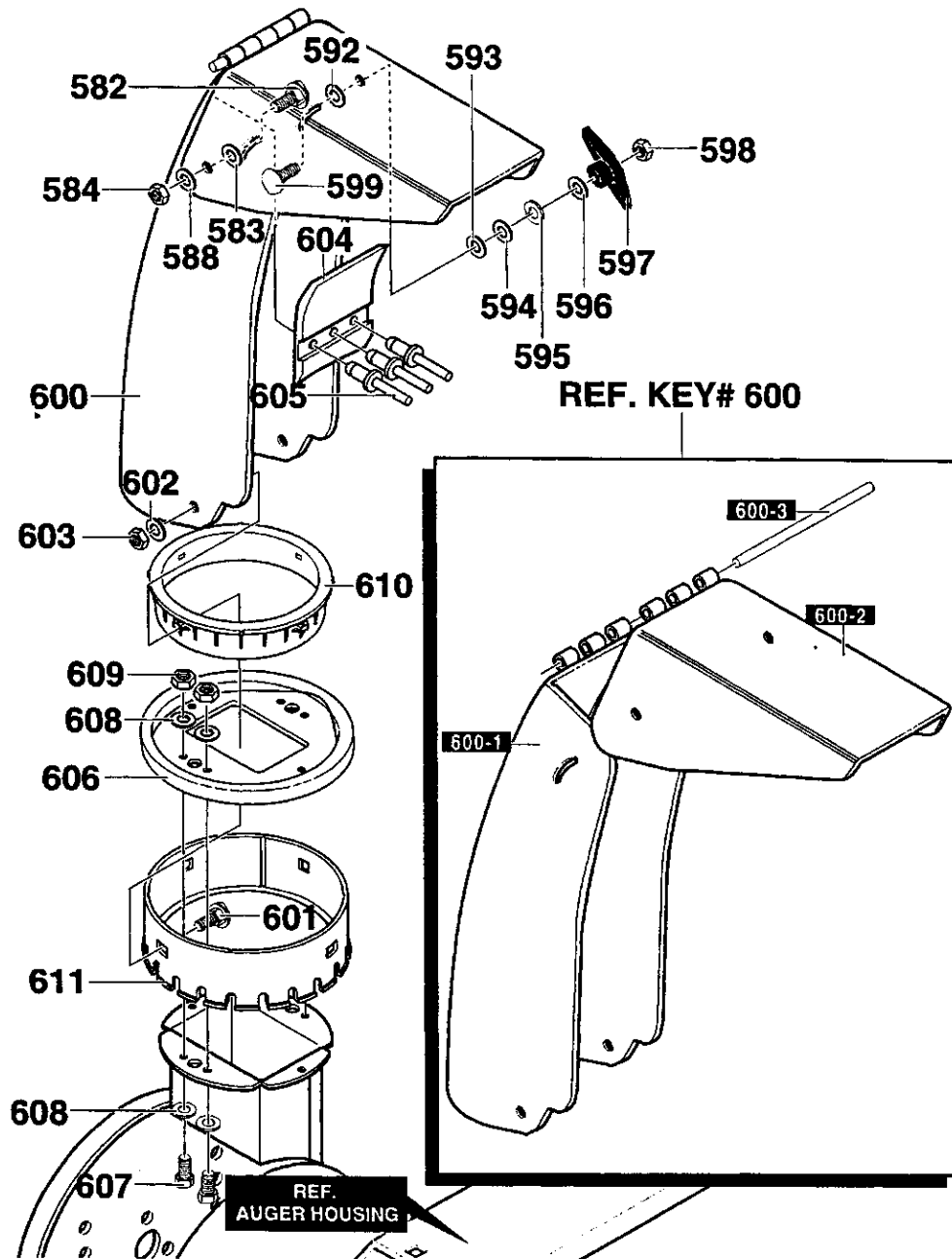

**CRAFTSMAN 24" 5HP SNOW THROWER 536.886440
DISCHARGE CHUTE ASSEMBLY**

Key No.	Description	Part No.
582	BOLT, 5/16-18 X.75	340720
583	WASHER , PLASTIC	12021
584	NUT, 5/16-18	71038
588	WASHER, PLASTIC	6711
592	WASHER, PLASTIC	12021
593	WASHER, PLASTIC	6711
594	FLATWASHER .349X.69X.066	71071
595	WASHER, SPLITLOCK	71060
596	FLATWASHER .349X.69X.066	71071
597	KNOB, T 2/BLADE W/NUT	57171
598	NUT, 5/16-18 REGHEX	71037
599	CARR. BOLT, 5/16-18X1.00	3316
600	CHUTE	760990-853
600-1	CHUTE, LOWER	760989
600-2	CHUTE, UPPER	11780
600-3	HINGE	305216
601	BOLT, 5/16-18 X1.00	586280
602	WASHER, FLAT .349 X.69 X.066	71071
603	NUT, 5/16-18 HEXNYL	71038
604	FLAP, CHUTE	760268
605	POP, RIVET	760987
606	CHUTE COLLAR	585214-853
607	SCREW, 1/4-20X.75	302628
608	WASHER, FLAT .281X.63X.065	71067
609	NUT, 1/4-20 HEX NYLOCK	780029
610	RETAINER, RING INNER	337227
611	RETAINER, RING OUTER	585193

CRAFTSMAN 24" 5HP SNOW THROWER 536.886440

HANDLE ASSEMBLY

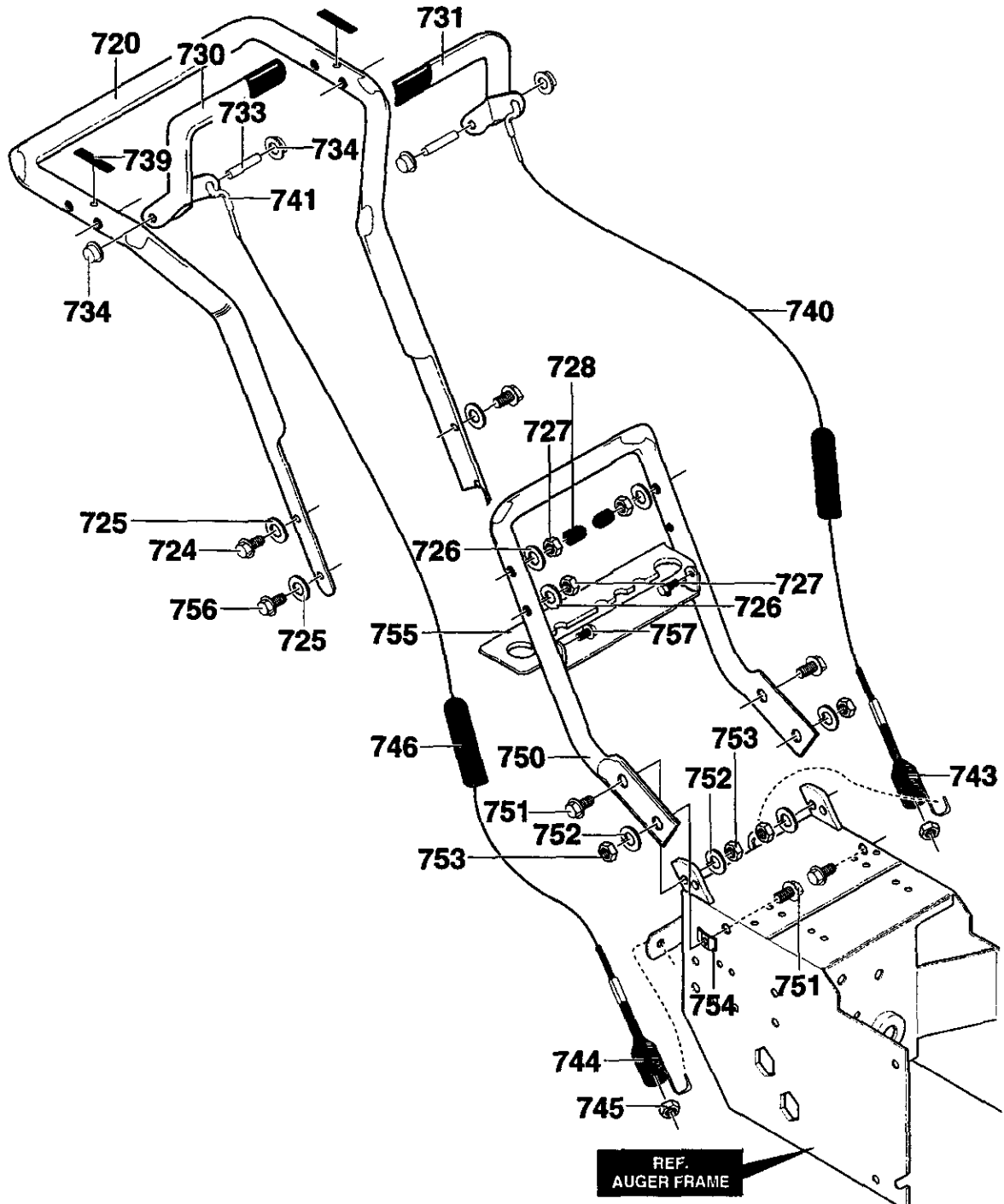

339622

**CRAFTSMAN 24" 5HP SNOW THROWER 536.886440
HANDLE ASSEMBLY**

Key No.	Description	Part No.
720	HANDLE, UPPER	9552-853
724	SCREW, 5/16-18X2.75	11234
725	WASHER, FLAT .349X.69X.066	71071
726	WASHER, SPTLK .31X.58X.08	71060
727	NUT, 5/16-18 REGHEX	71037
728	STOP, RED PLASTIC	11261
730	SET OF CLUTCH HANDLE LH & RH	334195
731	SET OF CLUTCH HANDLE LH & RH	334195
733	PIN, CLUTCH HANDLE	4140
734	NUT, PUSH ON CAP	3535
739	BUMPER, RECTANGLE	4049
740	CABLE, CLUTCH 28.44L	1579
741	CABLE, AUGER CLUTCH	761590
743	TENSION SPRING	579869
744	SPRING, AUGER CLUTCH	1673
745	NUT, 1/4-20	780029
746	BOOT, CLUTCH SPRING	308146
750	HANDLE, LOWER	339541-853
751	SCREW, 5/16-18 X1.00	313053
752	WASHER, SPTLK	71060
753	NUT, 5/16-18 REGHEX	71037
754	PUSHNUT, 5/16 BOLT RETAINER	309436
755	BRKT, GEAR SELECTOR	337407-853
756	SCREW, 5/16-18X2.00	6751
757	SCREW, .25X.75X.51	300303

CRAFTSMAN 24" 5HP SNOW THROWER 536.886440 WHEEL ASSEMBLY

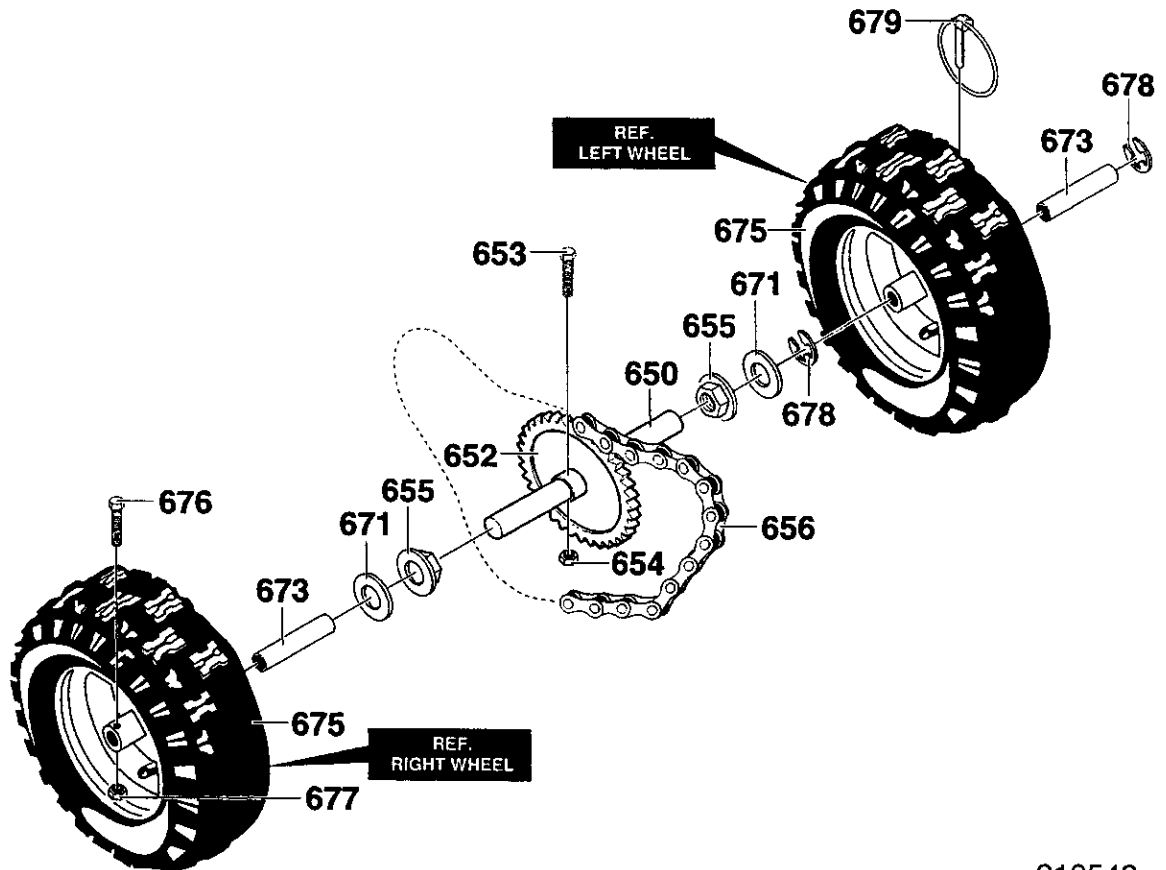

318542

Key No.	Description	Part No.
650	SHAFT, AXLE	580883
652	SPRKT & HUB	583012
653	SCREW, 1/4-20X2.25	73839
654	NUT, 1/4-20 HEX NYLOCK	780029
655	BRNG, FL	581730
656	CHAIN, ROLLER	579867
	LINK, CHAIN MASTER	760504
671	FLATWASHER .765X1.12X.06	712120
673	BUSHING, WHEEL	585591
675	TIRE & RIM	318504
676	SCREW, 1/4-20X1.75 HH	577015
677	NUT, 1/4-20 HEX NYLOCK	780029
678	RING, RET	239
679	PIN, KLIK .25 X 1.38 DIA	73842

CRAFTSMAN 24" 5HP SNOW THROWER 536.886440

SHIFT YOKE ASSEMBLY

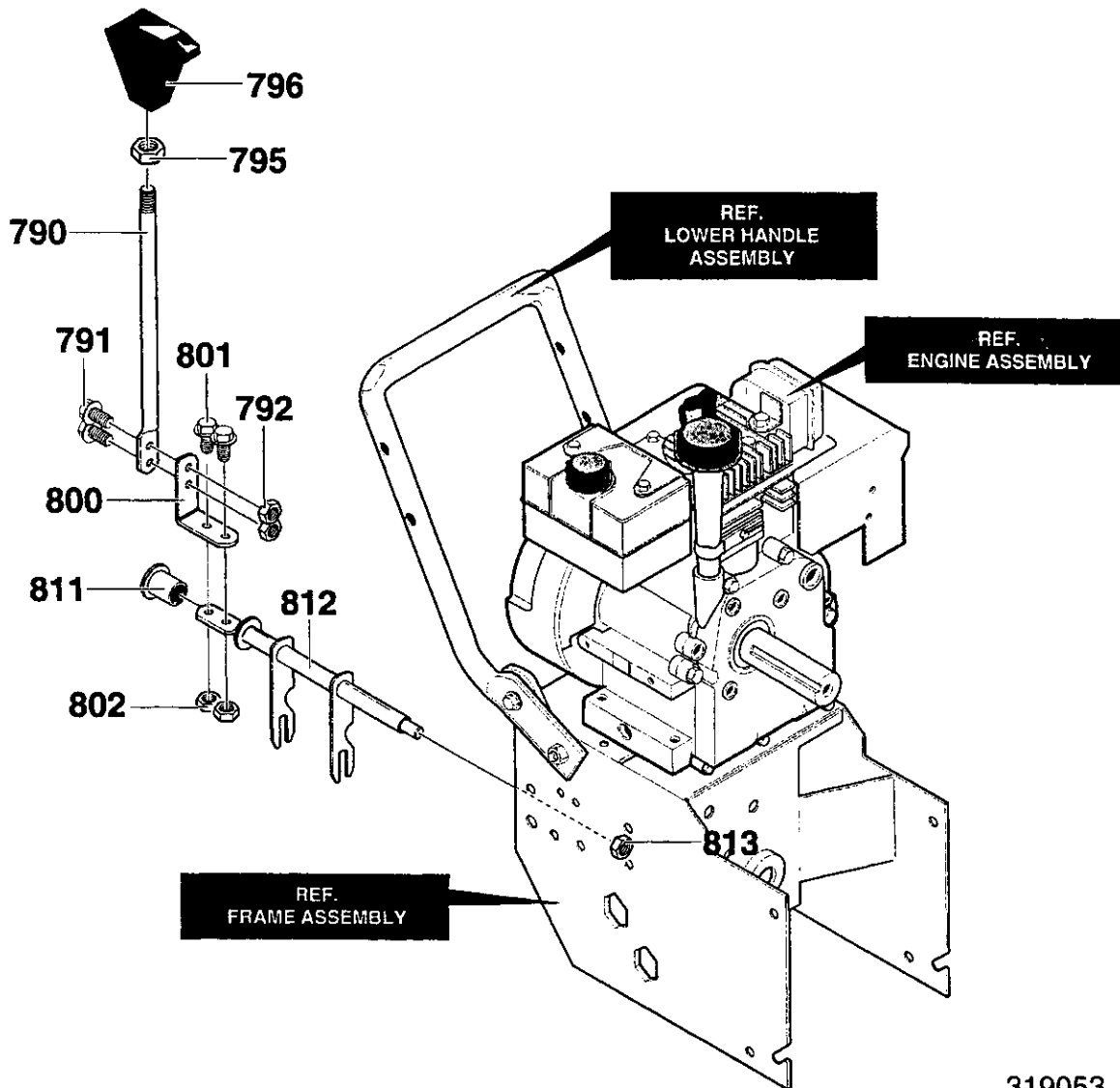

319053

Key No.	Description	Part No.
790	ROD, SHIFT	581631-853
791	SCREW, 1/4-20X.75	302628
792	NUT, 1/4-20 REGHEXCTRLK	73826
795	NUT, 1/2-13 HEXJAM	318486
796	KNOB, SHIFT	304438
800	LEVER, SPRING SHIFT	760564
801	SCREW, 1/4-20X.75	302628
802	NUT, 1/4-20 REGHEXCTRLK	73826
811	BEARING, FLANGED	579944
812	ROD, ASSY. YOKE	581795
813	NUT, 3/8-16 HEXCTRLK	71111

CRAFTSMAN 24" 5HP SNOW THROWER 536.886440

CHUTE CONTROL ROD ASSEMBLY

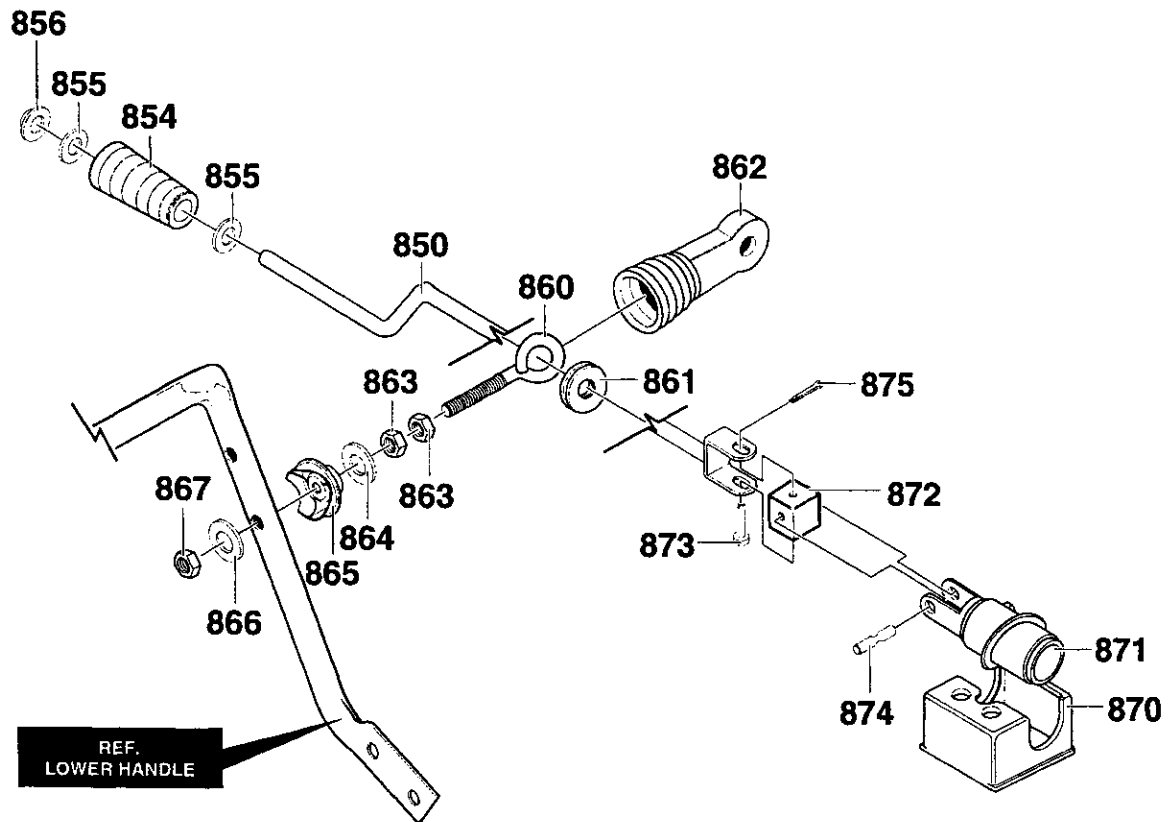

334215

Key No.	Description	Part No.
850	CRANK, ASSY CHUTE	585426
854	HANDLE, CHUTE CRANK	307399
855	FLATWASHER .39X.70X.05	309312
856	E RING	578159
860	EYE BOLT 3/8-16X6.00	581618
861	GROMMET, EYE BOLT	148
862	BOOT	308145
863	NUT, 3/8-16 HEXJAM	71045
864	FLATWASHER .406X.81X.066	71072
865	ADAPTER, BOOT TO HANDLE	309344
866	FLATWASHER .406X.81X.066	71072
867	NUT, 3/8-16 HEXNYL	71046
870	BRACKET, WORM MTG	585195
871	WORM, GEAR CHUTE ROTATION	585196
872	BLOCK, UNIVERSAL PIVOT	578063
873	CLEVIS PIN	578309
874	PIN, UNIVERSAL JOINT	578060
875	COTTER PIN	579493

CRAFTSMAN 24" 5HP SNOW THROWER 536.886440 DECALS

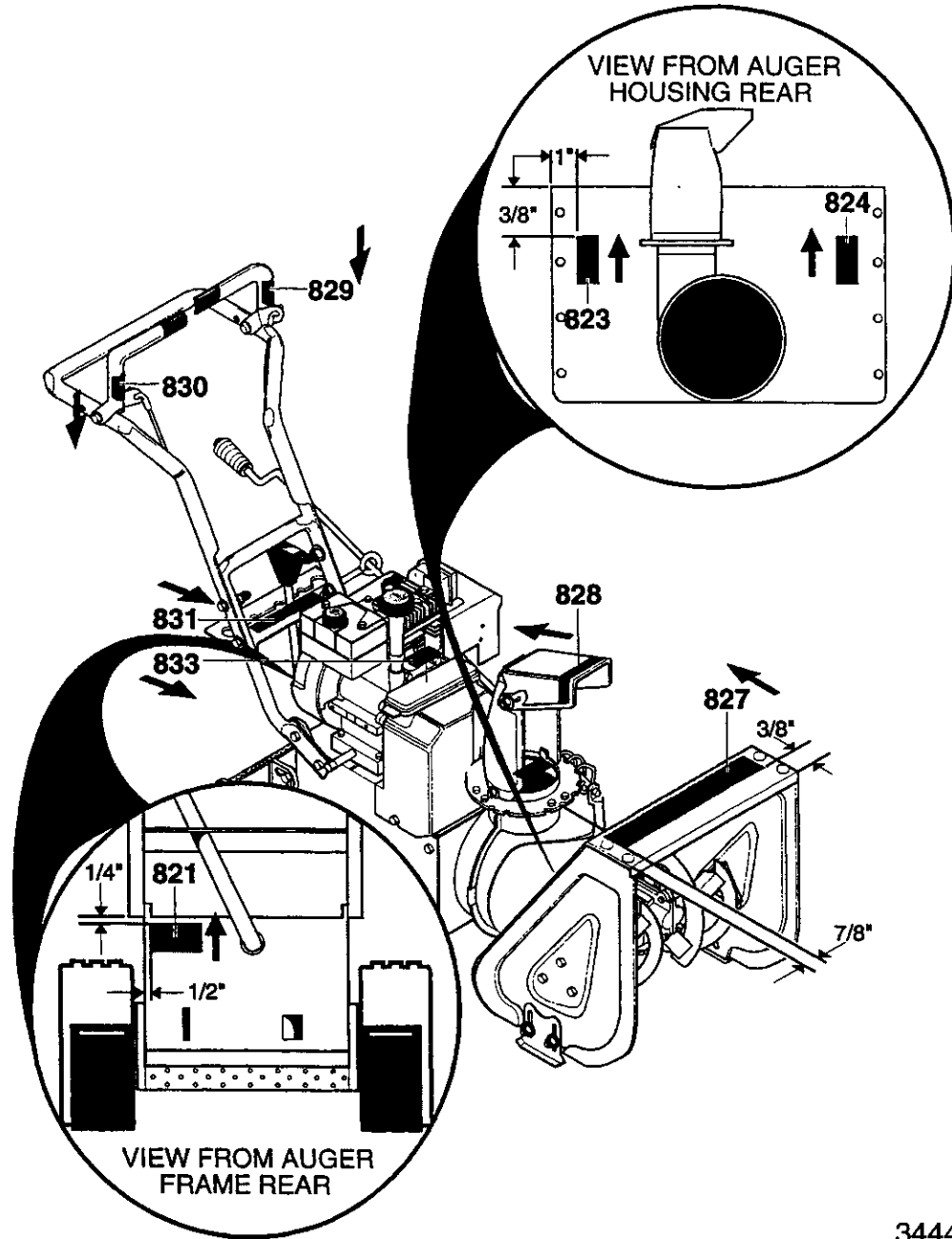

344409

Key No.	Description	Part No.
821	MODEL PLATE	
823	DECAL, DANGER CHUTE HAND	761916
824	DECAL, DANGER & FOOT	761776
827	DECAL, 5/24 CRAFTSMAN	48X250
828	DECAL, DANGER STRIPE	761079
829	DECAL, DRIVE CLUTCH (SYMBOL)	3902
830	DECAL, AUGER CLUTCH (SYMBOL)	3903
831	DECAL, GEAR SELECTOR	340047
833	DECAL, TOOLBOX INFO	760983

CRAFTSMAN 4-CYCLE ENGINE MODEL NUMBER 143.015005

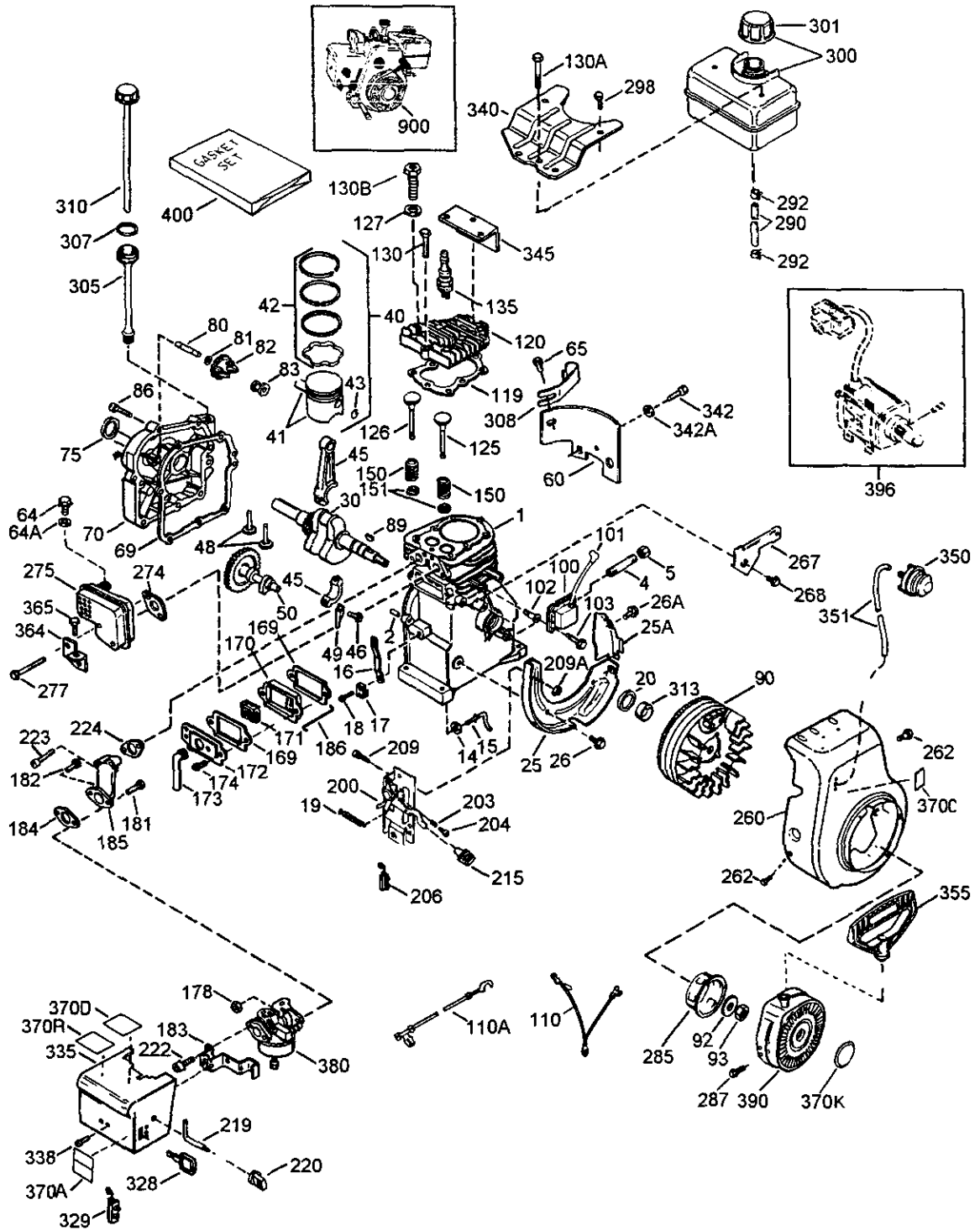

CRAFTSMAN 4-CYCLE ENGINE MODEL NUMBER 143.015005

KEY NO.	PART NO.	DESCRIPTION	KEY NO.	PART NO.	DESCRIPTION
	0	RPM High 3550 to 3850	49	32654	Oil Dipper
	0	RPM Low 1850 to 2150	50	33158	Camshaft (BCR)
1	36469A	Cylinder (Incl. 2, 20, 72 & 125)	60	29745	Blower Housing Extension
2	26727	Dowel Pin	64	30063	Screw
4	0	Oil Drain Extension (Purchase Local)	64A	8345	Washer
5	30969	Extension Cap	65	650128	Screw, 10-24 x 1/2"
14	28277	Washer	69	27677A	Cylinder Cover Gasket
15	31334	Governor Rod	70	34674C	Cylinder Cover (Incl. 75 thru 83)
16	31510	Governor Lever	75	27897	Oil Seal
17	31335	Governor Lever Clamp	80	30574A	Governor Shaft
18	651018	Screw	81	30590A	Washer
19	31426	Throttle Spring	82	30591	Governor Gear Ass'y. (Incl. 81)
20	32600	Oil Seal	83	30588A	Governor Spool
25	36552	Blower Housing Baffle (Incl. 262)	86	650488	Screw, 1/4-20 x 1-1/4"
25A	35883	Baffle Extension	89	610961	Flywheel Key
26	650802	Screw, 1/4-20 x 5/8"	90	611199	Flywheel (W/Ring Gear)
26A	650926	Screw, 8-32 x 21/64"	92	650815	Belleville Washer
30	37245	Crankshaft	93	650816	Flywheel Nut
40	36073	Piston, Pin & Ring Set (Std.)	100	34443B	Solid State Ignition
40	36074	Piston, Pin & Ring Set (.010" OS)	101	610118	Spark Plug Cover
40	36075	Piston, Pin & Ring Set (.020" OS)	102	651024	Solid State Mounting Stud
41	36070	Piston & Pin Ass'y. (Std.) (Incl. 43)	103	651007	Screw
41	36071	Piston & Pin Ass'y. (.010" OS) (Incl. 43)	110	35182	Ground Wire
41	36072	Piston & Pin Ass'y. (.020" OS) (Incl. 43)	110A	36874	Ground Wire
42	36076	Ring Set (Std.)	119	36443	Cylinder Head Gasket
42	36077	Ring Set (.010" OS)	120	36441	Cylinder Head (Incl. 131)
42	36078	Ring Set (.020" OS)	125	36471	Exhaust Valve (Std.) (Incl. 151)
43	20381	Piston Pin Retaining Ring	125	36472	Exhaust Valve (1/32" OS) (Incl. 151)
45	32875A	Connecting Rod Ass'y. (Incl. 46 & 49)	126	32644A	Intake Valve (Std.) (Incl. 151)
46	32610A	Connecting Rod Bolt	127	650691	Washer
48	27241	Valve Lifter	130	6021A	Screw, 5/16-18 x 1-1/2"
			130A	650694A	Screw, 5/16-18 x 2"
			130B	650818	Screw, 5/16-18 x 1-1/2"
			135	35395	Spark Plug (RJ19LM)

CRAFTSMAN 4-CYCLE ENGINE MODEL NUMBER 143.015005

150	31672	Valve Spring	300	35584	Fuel Tank (Incl. 292 & 301)
151	31673	Valve Spring Cap			
169	27234A	Valve Cover Gasket	301	35355	Fuel Cap
170	27666	Breather Body	305	35554	Oil Fill Tube
171	31410	Breather Element	307	35499	"O" Ring
172	34146	Valve Cover	308	35539	Fill Tube Clip
173	35350	Breather Tube	310	35556	Dipstick
174	650783	Screw, 10-24 x 3/4"	313	34080	Spacer
178	29752	Nut & Lock Washer	328	35062	Ignition Key
181	650870	Screw, 1/4-28 x 1-11/16"	329	610973	Terminal
182	6201	Screw, 1/4-28 x 7/8"	335	35072	Carburetor Cover
183	34583A	Choke Bracket	338	650257	Screw, 8-32 x 5/16"
184	26756	Gasket	340	36247	Fuel Tank Bracket
185	33691	Intake Pipe	342	30063	Screw, Torx T-30
186	32698	Governor Link	342A	650675	Washer
200	36677	Control Bracket (Incl. 203 thru 209A)	345	33344	Heat Baffle
203	31342	Compression Spring	350	570682A	Primer Ass'y.
204	651029	Screw, Torx T-10	351	32180C	Primer Line
206	610973	Terminal	355	590574	Starter Handle
209	650139	Screw, 8-32 x 3/4"	364	33333	Carburetor Cover Bracket
209A	30322	Lock Nut, 8-32	365	650735	Screw, 10-24 x 3/8"
215	35440	Control Knob	370A	36261	Lubrication Decal
219	34582	Choke Rod	370C	36501	Primer Decal
220	35438	Choke Knob	370D	35282	Caution Decal
222	28820	Screw, 10-32 x 1/2"	370K	36695	Starter Decal
223	650664	Screw, 1/4-20 x 1-19/32"	370R	35878	Warning Decal
224	33673A	Intake Pipe Gasket	380	640084A	Carburetor (Incl. 184)
260	35656A	Blower Housing	390	590742	Rewind Starter
262	650737	Screw, 1/4-20 x 1/2"	396	33290E	Electric Starter Motor (110 Volt) (Optional)
267	34212	Hold Down Bracket	400	36444	Gasket Set (Incl. Items Marked PK in Notes)
268	30200	Screw, 10-24 x 9/16"			Incl. part #'s 26756 (1), 27234A (2), 27272A (1), 27677A (1), 29673 (1), 36443 (1), 33670A (1), 33673A (1)
274	33670A	Exhaust Gasket			
275	35771A	Muffler (Incl. 274)			
277	650327	Screw, 1/4-20 x 2-27/64"			
285	36467A	Starter Cup	900	0	Replacement Engine NONE
287	650926	Screw, 8-32 x 21/64"	900	0	Replacement S/B 754273B, order from 71-999
290	30705	Fuel Line			
292	26460	Fuel Line Clamp			
298	650665	Screw, 1/4-15 x 3/4"			

CRAFTSMAN 4-CYCLE ENGINE MODEL NUMBER 143.015005

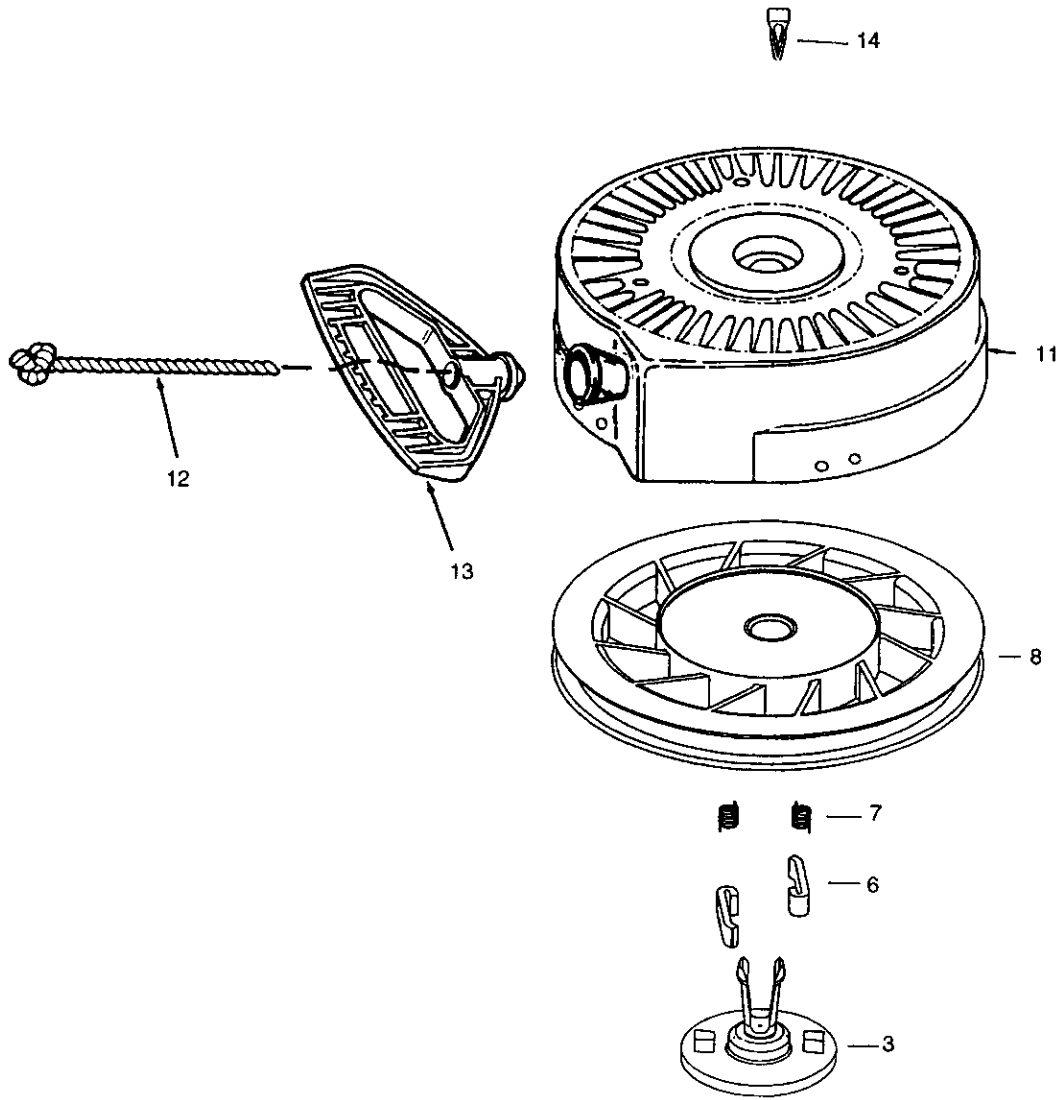

KEY NO.	PART NO.	DESCRIPTION
0	590742	Rewind Starter
3	590740	Retainer
6	590616	Starter Dog
7	590617	Dog Spring
8	590645A	Pulley & Rewind Spring Ass'y
11	590647	Starter Housing Ass'y
12	590535	Starter Rope (Length 98" x 9/64" dia.)
13	590574	Mitten Grip Handle (Not included w/starter)
14	590760	Spring Clip

CRAFTSMAN 4-CYCLE ENGINE MODEL NUMBER 143.015005

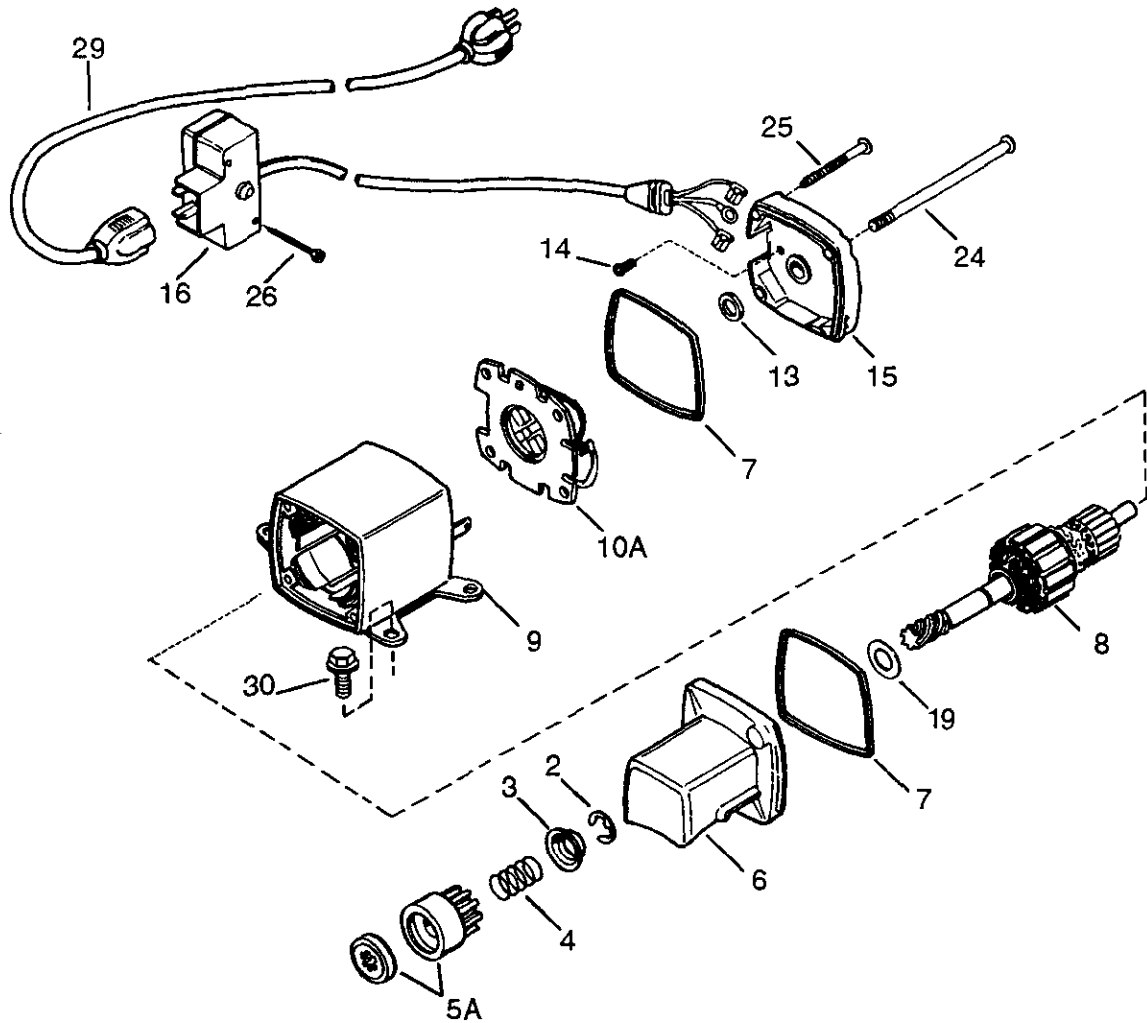

CRAFTSMAN 4-CYCLE ENGINE MODEL NUMBER 143.015005

KEY NO.	PART NO.	DESCRIPTION
0	33290E	Electric Starter (110 Volt)
2	31749	Retainer Ring
3	33522	Spring Retainer
4	33769	Anti-drift Spring
5A	37332	Nut & Gear (Incl. 2)
6	35461	Drive End Cap Ass'y. (Incl. 7)
7	35450	"O" Ring
8	35912	Armature
9	0	Housing Ass'y. (Must Purchase Complete Motor)
10A	35452A	Brush & Spring Card Ass'y.
13	590500	Thrust Washer
14	33441	Ground Screw
15	35453	Commutator End Cap Ass'y. (Incl. 7)
16	35454	Switch Box Ass'y.
19	35911	Thrust Washer
24	35462	Case Bolt
25	35456	Grounding Screw
26	650819	Screw, 6-32 x 2-1/2"
26	651032	Screw, 12-16 x 5/8"
29	32450B	Extension Cord (10' 6")
30	650759	Screw, Torx T-30, 1/4-20 x 23/32"

CRAFTSMAN 4-CYCLE ENGINE MODEL NUMBER 143.015005

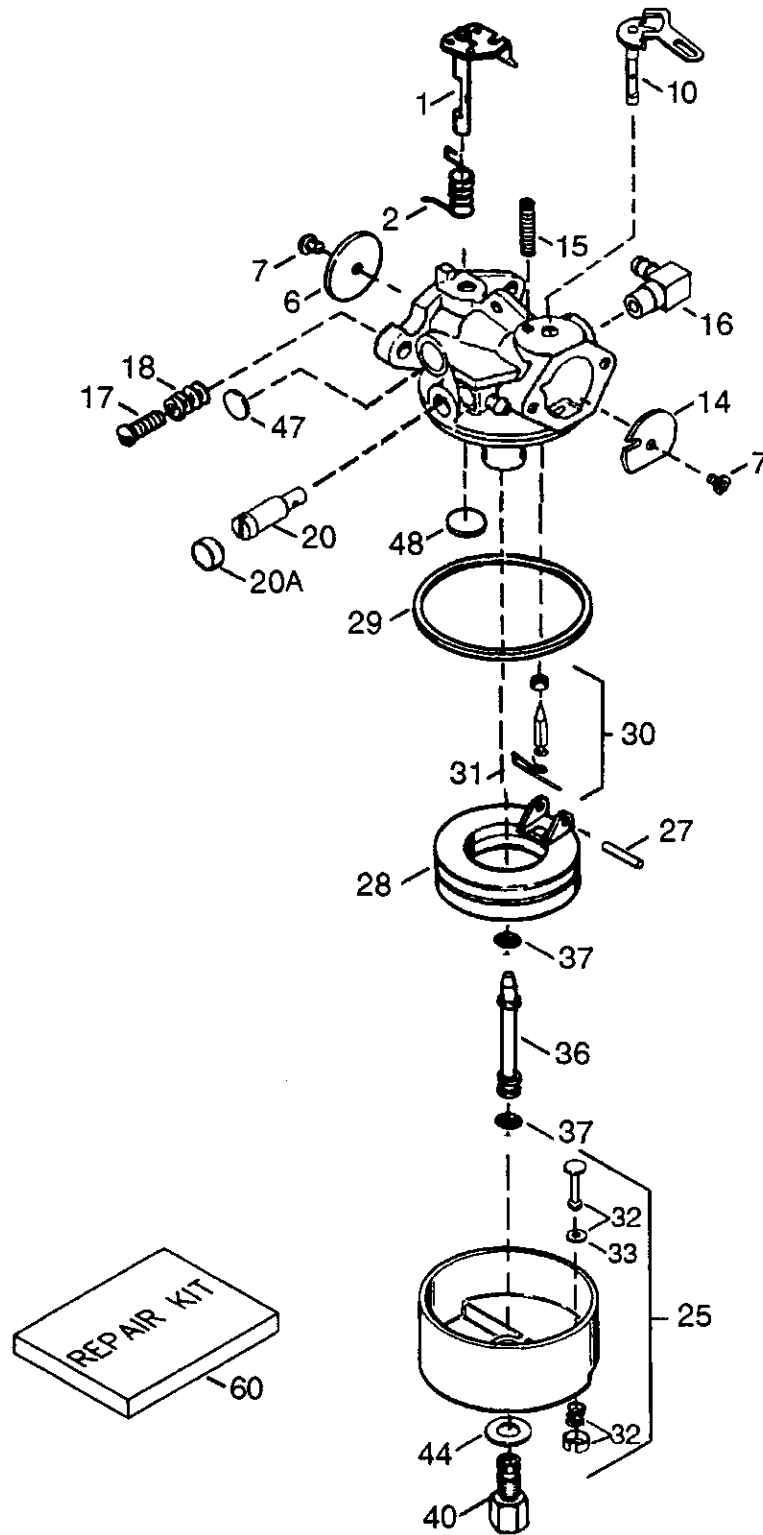

CRAFTSMAN 4-CYCLE ENGINE MODEL NUMBER 143.015005

KEY NO.	PART NO.	DESCRIPTION
0	640084A	Carburetor (Incl. 184 of Engine Parts List)
1	631615	Throttle Shaft & Lever Assembly
2	631767	Throttle Return Spring
6	640070	Throttle Shutter
7	650506	Shutter Screw
10	632108	Choke Shaft & Lever Assembly
14	631890	Choke Shutter
15	630735	Choke Positioning Spring
16	631807	Fuel Fitting
17	651025	Throttle Crack Screw/Idle Speed Screw
18	630766	Tension Spring
20	640027	Idle Restrictor Screw
20A	640053	Idle Restrictor Screw Cap
25	631951	Float Bowl Ass'y (Incl. 32 & 33)
27	631024	Float Shaft
28	632019	Float
29	631028	Float Bowl "O" Ring
30	631021	Inlet Needle, Seat & Clip (Incl. 31)
31	631022	Spring Clip
32	27136A	Bowl Drain Assembly
33	27554	Drain Plunger Gasket
36	632745	Main Nozzle Tube
37	632547	"O" Ring, Main Nozzle Tube
40	640183	High Speed Bowl Nut
44	27110A	Bowl Nut Washer
47	630748	Welch Plug, Idle Mixture Well
48	631027	Welch Plug, Atmospheric Vent
60	632760	Repair kit (Incl. Items Marked PK in Notes)

For the repair or replacement parts you need delivered directly to your home
Call 7am-7pm, 7days a week

1-800-366-PART

(1-800-366-7278)

Para ordenar piezas con entrega a domicilio - 1-800-659-7084

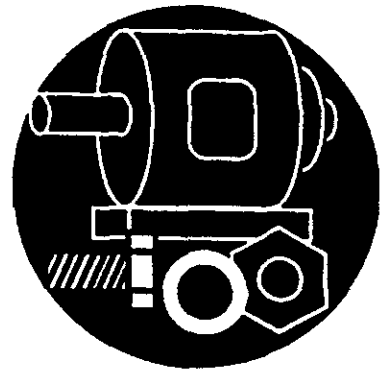

For in-house major brand repair service
Call 24 hours a day, 7days a week

1-800-4-REPAIR

(1-800-473-7247)

Para pedir servicio de reparación a domicilio- 1-800-676-5811



For the location of a Sears Parts and Repair Center in your area

Call 24 hours a day, 7days a week

1-800-488-1222



For information on purchasing a Sears Maintenance agreement or to inquire about an existing Agreement

Call 9am-5pm, Monday-Saturday

1-800-827-6655



When requesting service or ordering parts, always provide the following information:

- Product Type
- Part Number
- Model Number
- Part Description

SEARS
REPAIR SERVICES

America's Repair Specialists