

Owner's Manual



**6.25 HORSEPOWER
22" SIDE DISCHARGE
ROTARY LAWN MOWER**

Model No.
917.387441

- **Safety**
- **Assembly**
- **Operation**
- **Maintenance**
- **Español**
- **Repair Parts**

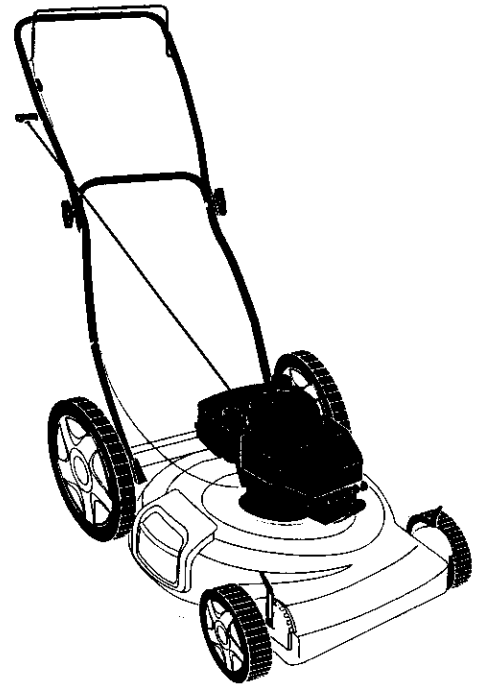

CAUTION:

Read and follow all
Safety Rules and Instructions
before operating this equipment

Sears, Roebuck and Co., Hoffman Estates, IL 60179
Visit our Craftsman website: www.sears.com/craftsman

TABLE OF CONTENTS

Warranty	2	Product Specifications	11
Safety Rules	2	Service and Adjustments	14
Assembly	5	Storage	15
Operation	6	Troubleshooting	16
Maintenance Schedule	10	Repair Parts	34
Maintenance	10	Parts Ordering	Back Cover

WARRANTY

LIMITED TWO YEAR WARRANTY ON CRAFTSMAN POWER MOWER

For two years from date of purchase, when this Craftsman Lawn Mower is maintained, lubricated, and tuned up according to the operating and maintenance instructions in the owner's manual, Sears will repair free of charge any defect in material or workmanship.

If this Craftsman Lawn Mower is used for commercial or rental purposes, this warranty applies for only 90 days from the date of purchase.

This Warranty does not cover:

- Expendable items which become worn during normal use, such as rotary mower blades, blade adapters, belts, air cleaners and spark plug.
- Repairs necessary because of operator abuse or negligence, including bent crankshafts and the failure to maintain the equipment according to the instructions contained in the owner's manual.

Warranty service is available by returning the Craftsman power mower to the nearest Sears Service Center/Department in the United States. This warranty applies only while this product is in use in the United States.

This Warranty gives you specific legal rights, and you may also have other rights which vary from state to state.

SEARS, ROEBUCK AND CO., D/817 WA, HOFFMAN ESTATES, ILLINOIS 60179

SAFETY RULES

IMPORTANT: This cutting machine is capable of amputating hands and feet and throwing objects. Failure to observe the following safety instructions could result in serious injury or death.

I. GENERAL OPERATION

- Read, understand, and follow all instructions on the machine and in the manual(s) before starting. Be thoroughly familiar with the controls and the proper use of the machine before starting.
- Do not put hands or feet near or under rotating parts. Keep clear of the discharge opening at all times.
- Only allow responsible individuals, who are familiar with the instructions, to operate the machine.
- Clear the area of objects such as rocks, toys, wire, bones, sticks, etc., which could be picked up and thrown by the blade.
- Be sure the area is clear of other people before mowing. Stop machine if anyone enters the area.
- Do not operate the mower when barefoot or wearing open sandals. Always wear substantial foot wear.
- Do not pull mower backwards unless absolutely necessary. Always look down and behind before and while moving backwards.
- Do not operate the mower without proper guards, plates, grass catcher or other safety protective devices in place.
- See manufacturer's instructions for proper operation and installation of accessories. Only use accessories approved by the manufacturer.
- Stop the blade(s) when crossing gravel drives, walks, or roads.
- Stop the engine (motor) whenever you leave the equipment, before cleaning the mower or unclogging the chute.

- Shut the engine (motor) off and wait until the blade comes to complete stop before removing grass catcher.
- Mow only in daylight or good artificial light.
- Do not operate the machine while under the influence of alcohol or drugs.
- Never operate machine in wet grass. Always be sure of your footing: keep a firm hold on the handle and walk; never run.
- Disengage the self-propelled mechanism or drive clutch on mowers so equipped before starting the engine (motor).
- If the equipment should start to vibrate abnormally, stop the engine (motor) and check immediately for the cause. Vibration is generally a warning of trouble.
- Always wear safety goggles or safety glasses with side shields when operating mower.

II. SLOPE OPERATION

Slopes are a major factor related to slip and fall accidents which can result in severe injury. All slopes require extra caution. If you feel uneasy on a slope, do not mow it.

DO:

- Mow across the face of slopes: never up and down. Exercise extreme caution when changing direction on slopes.
- Remove obstacles such as rocks, tree limbs, etc.
- Watch for holes, ruts, or bumps. Tall grass can hide obstacles.

DO NOT:

- Do not trim near drop-offs, ditches or embankments. The operator could lose footing or balance.
- Do not trim excessively steep slopes.
- Do not mow on wet grass. Reduced footing could cause slipping.

III. CHILDREN

Tragic accidents can occur if the operator is not alert to the presence of children. Children are often attracted to the machine and the mowing activity. *Never* assume that children will remain where you last saw them.

- Keep children out of the trimming area and under the watchful care of another responsible adult.
- Be alert and turn machine off if children enter the area.

- Before and while walking backwards, look behind and *down* for small children.
- Never allow children to operate the machine.
- Use extra care when approaching blind corners, shrubs, trees, or other objects that may obscure vision.

IV. SERVICE

- Use extra care in handling gasoline and other fuels. They are flammable and vapors are explosive.
 - Use only an approved container.
 - Never remove gas cap or add fuel with the engine running. Allow engine to cool before refueling. Do not smoke.
 - Never refuel the machine indoors.
 - Never store the machine or fuel container inside where there is an open flame, such as a water heater.
- Never run a machine inside a closed area.
- Never make adjustments or repairs with the engine (motor) running. Disconnect the spark plug wire, and keep the wire away from the plug to prevent accidental starting.
- Keep nuts and bolts, especially blade attachment bolts, tight and keep equipment in good condition.
- Never tamper with safety devices. Check their proper operation regularly.
- Keep machine free of grass, leaves, or other debris build-up. Clean oil or fuel spillage. Allow machine to cool before storing.
- Stop and inspect the equipment if you strike an object. Repair, if necessary, before restarting.
- Never attempt to make wheel height adjustments while the engine (motor) is running.
- Grass catcher components are subject to wear, damage, and deterioration, which could expose moving parts or allow objects to be thrown. Frequently check components and replace with manufacturer's recommended parts, when necessary.
- Mower blades are sharp and can cut. Wrap the blade(s) or wear gloves, and use extra caution when servicing them.
- Do not change the engine governor setting or overspeed the engine.

⚠ Look for this symbol to point out important safety precautions. It means **CAUTION!!! BECOME ALERT!!! YOUR SAFETY IS INVOLVED.**

⚠ WARNING: In order to prevent accidental starting when setting up, transporting, adjusting or making repairs, always disconnect spark plug wire and place wire where it cannot contact spark plug.





⚠ WARNING: Engine exhaust, some of its constituents, and certain vehicle components contain or emit chemicals known to the State of California to cause cancer and birth defects or other reproductive harm.

⚠ WARNING: Battery posts, terminals and related accessories contain lead and lead compounds, chemicals known to the State of California to cause cancer and birth defects or other reproductive harm. **Wash hands after handling.**



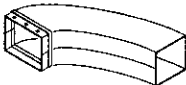

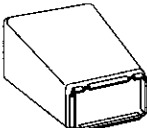
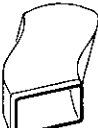

ACCESSORIES

These accessories were available when this lawn mower was produced. **They are not shipped with your mower.** They are also available at most Sears retail outlets and service centers. Most Sears stores can also order repair parts for you, when you provide the model number of your lawn mower. Some of these accessories may not apply to your lawn mower.

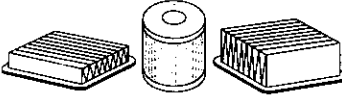
LAWN MOWER PERFORMANCE

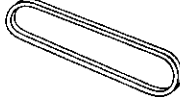
 CLIPPING DEFLECTOR FOR REAR DISCHARGE LAWN MOWERS	 MULCHER KITS	 STABILIZER
 GRASS CATCHERS FOR REAR DISCHARGE LAWN MOWERS	 GRASS CATCHERS FOR SIDE DISCHARGE LAWN MOWERS	 GAS CANS

LAWN MOWER MAINTENANCE

 MUFFLERS		 AIR FILTERS		 SPARK PLUGS
 BELTS	 BLADES	 BLADE ADAPTERS	 WHEELS	 ENGINE OIL

ASSEMBLY

Read these instructions and this manual in its entirety before you attempt to assemble or operate your new lawn mower.

IMPORTANT: This lawn mower is shipped **WITHOUT OIL OR GASOLINE** in the engine.

Your new lawn mower has been assembled at the factory with the exception of those parts left unassembled for shipping purposes. All parts such as nuts, washers, bolts, etc., necessary to complete the assembly have been placed in the parts bag. To ensure safe and proper operation of your lawn mower, all parts and hardware you assemble must be tightened securely. Use the correct tools as necessary to ensure proper tightness.

TO REMOVE LAWN MOWER FROM CARTON

1. Remove loose parts included with mower.
2. Cut down two end corners of carton and lay end panel down flat.
3. Remove all packing materials except padding between upper and lower handle and padding holding operator presence control bar to upper handle.
4. Roll lawn mower out of carton and check carton thoroughly for additional loose parts.

HOW TO SET UP YOUR LAWN MOWER

TO UNFOLD HANDLE

IMPORTANT: Unfold handle carefully so as not to pinch or damage control cables.

1. Raise handles until lower handle section locks into place in mowing position.
2. Remove protective padding, raise upper handle section into place on lower handle and tighten both handle knobs.
3. Remove handle padding holding operator presence control bar to upper handle.

Your lawn mower handle can be adjusted for your mowing comfort. Refer to "Adjust Handle" in the Service and Adjustments section of this manual.

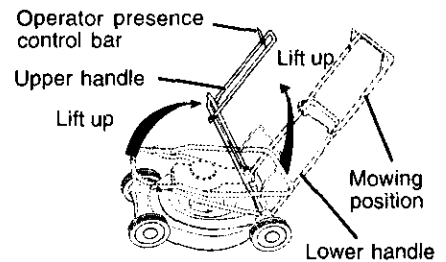

OPERATION

KNOW YOUR LAWN MOWER

READ THIS OWNER'S MANUAL AND SAFETY RULES BEFORE OPERATING YOUR LAWN MOWER. Compare the illustrations with your lawn mower to familiarize yourself with the location of various controls and adjustments. Save this manual for future reference.

These symbols may appear on your lawn mower or in literature supplied with the product. Learn and understand their meaning.

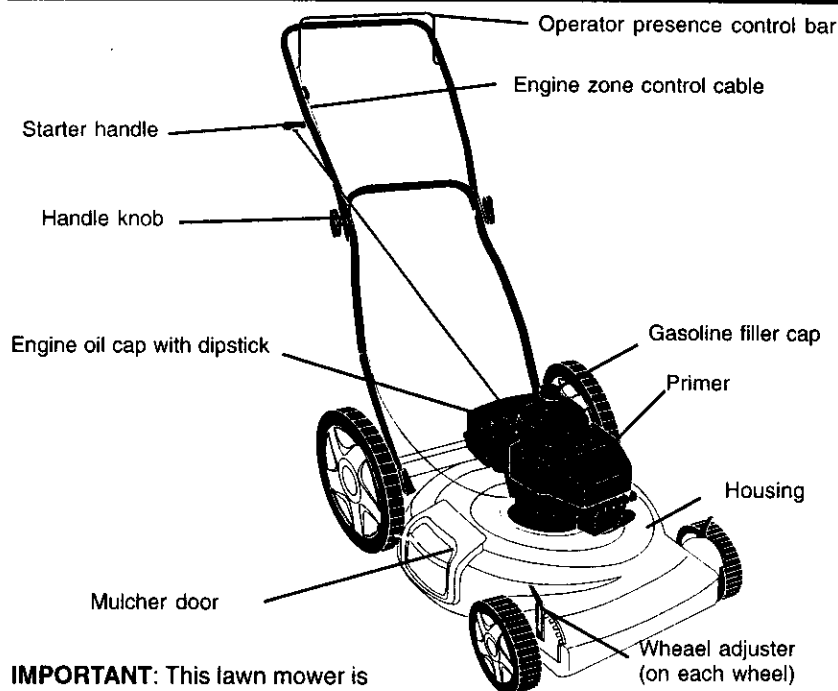
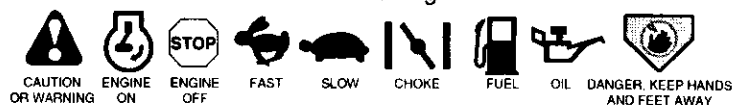

IMPORTANT: This lawn mower is shipped without oil or gasoline in the engine.

MEETS CPSC SAFETY REQUIREMENTS

Sears rotary walk-behind power lawn mowers conform to the safety standards of the American National Standards Institute and the U.S. Consumer Product Safety Commission. The blade turns when the engine is running.

Operator presence control bar - must be held down to the handle to start the engine. Release to stop the engine.
Primer - pumps additional fuel from the carburetor to the cylinder for use when starting a cold engine.

Starter handle - used for starting the engine.
Mulcher Door - allows conversion to discharge or bagging operation.



The operation of any lawn mower can result in foreign objects thrown into the eyes, which can result in severe eye damage.

Always wear safety glasses or eye shields while operating your lawn mower or performing any adjustments or repairs. We recommend a wide vision safety mask over spectacles or standard safety glasses.

HOW TO USE YOUR LAWN MOWER ENGINE SPEED

The engine speed was set at the factory for optimum performance. Speed is not adjustable.

ENGINE ZONE CONTROL

CAUTION: Federal regulations require an engine control to be installed on this lawn mower in order to minimize the risk of blade contact injury. Do not under any circumstances attempt to defeat the function of the operator control. The blade turns when the engine is running.

- Your lawn mower is equipped with an operator presence control bar which requires the operator to be positioned behind the lawn mower handle to start and operate the lawn mower.

TO ADJUST CUTTING HEIGHT

Raise wheels for low cut and lower wheels for high cut, adjust cutting height to suit your requirements. Medium position is best for most lawns.

- To change cutting height, squeeze adjuster lever toward wheel. Move wheel up or down to suit your requirements. Be sure all wheels are in the same setting.

NOTE: Adjuster is properly positioned when plate tab inserts into hole in lever. Also, 9-position adjusters (if so equipped) allow lever to be positioned between the plate tabs.

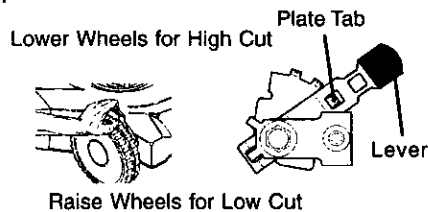

NOTE: Your lawn mower has been shipped ready for mulching operation. To convert to discharging operation, you must install the discharge deflector attachment included with your mower.

TO INSTALL DISCHARGING DEFLECTOR

- Lift door upward on its hinge until the deflector frame can be hooked over the door mounting bracket as shown.
 - Release the door to rest against deflector frame.
- To return to mulching operation, reverse the above steps and be sure door is in locked position.

CAUTION: Do not operate your lawn mower without mulcher door in locked position, discharge deflector in place, or approved grass catcher in place.

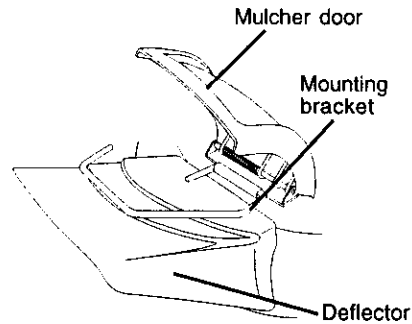

BEFORE STARTING ENGINE

ADD OIL

Your lawnmower is shipped without oil in the engine. Engine holds 20 oz. of oil. For type and grade of oil to use, see "ENGINE" in Maintenance section of this manual.

- Be sure lawnmower is level and area around oil fill is clean.
- Remove engine oil cap and fill to the full line on the dipstick. Pour oil slowly. Do not over fill.

NOTE: Allow oil to settle down into engine for accurate reading. To read proper level, tighten engine oil cap, then remove it to read the dipstick.

- Reinstall engine oil cap and tighten.
- Check oil level before each use. Add oil if needed. Fill to full line on dipstick
 - Change the oil after every 25 hours of operation or each season. You may need to change the oil more often under dusty, dirty conditions.

ADD GASOLINE

- Fill fuel tank. Use fresh, clean, regular unleaded gasoline with a minimum of 87 octane. Do not mix oil with gasoline. Purchase fuel in quantities that can be used within 30 days to assure fuel freshness.

⚠WARNING: Experience indicates that alcohol blended fuels (called gasohol or using ethanol or methanol) can attract moisture which leads to separation and formation of acids during storage. Acidic gas can damage the fuel system of an engine while in storage. To avoid engine problems, the fuel system should be emptied before storage of 30 days or longer. Drain the gas tank, start the engine and let it run until the fuel lines and carburetor are empty. Use fresh fuel next season. See Storage Instructions for additional information. Never use engine or carburetor cleaner products in the fuel tank or permanent damage may occur.

⚠CAUTION: Fill to bottom of gas tank filler neck. Do not overfill. Wipe off any spilled oil or fuel. Do not store, spill or use gasoline near an open flame.

TO START ENGINE

NOTE: Due to protective coatings on the engine, a small amount of smoke may be present during the initial use of the product and should be considered normal.

1. To start a cold engine, push primer three (3) times before trying to start. Use a firm push. This step is not usually necessary when starting an engine which has already run for a few minutes.
2. Hold operator presence control bar down to the handle and pull starter handle quickly. Do not allow starter rope to snap back.

TO STOP ENGINE

- To stop engine, release operator presence control bar.

NOTE: In cooler weather it may be necessary to repeat priming steps. In warmer weather over priming may cause flooding and engine will not start. If you do flood engine, wait a few minutes before attempting to start and do not repeat priming steps.

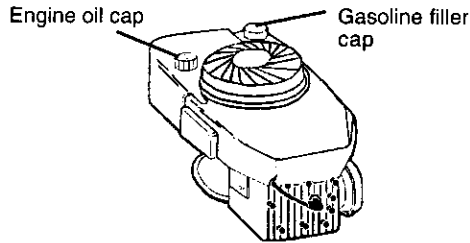

MOWING TIPS

- Under certain conditions, such as very tall grass, it may be necessary to raise the height of cut to reduce pushing effort and to keep from overloading the engine and leaving clumps of grass clippings. It may also be necessary to reduce ground speed and/or run the lawn mower over the area a second time.
- For extremely heavy cutting, reduce the width of cut by overlapping previously cut path and mow slowly.
- For better grass bagging and most cutting conditions, the engine speed should be set in the fast position.
- For side discharge lawn mowers, cutting in a counter-clockwise direction, starting at the outside of the area to be cut, spreads grass clippings more evenly and puts less load on the engine. To keep clippings off of walkways, flower beds, etc., make the first cuts in a clockwise direction.
- Pores in cloth grass catchers can become filled with dirt and dust with use and catchers will collect less grass. To prevent this, regularly hose catcher off with water and let dry before using.
- Keep top of engine around starter clear and clean of grass clippings and chaff. This will help engine air flow and extend engine life.

MULCHING MOWING TIPS

IMPORTANT: For best performance, keep mower housing free of built-up grass and trash. See "Cleaning" in MAINTENANCE section of this manual.

- The special mulching blade will recut the grass clippings many times and reduce them in size so that as they fall onto the lawn they will disperse into the grass and not be noticed. Also, the mulched grass will biodegrade quickly to provide nutrients for the lawn. Always mulch with your highest engine (blade) speed as this will provide the best recutting action of the blades.
- Avoid cutting your lawn when it is wet. Wet grass tends to form clumps and interferes with the mulching action. The best time to mow your lawn is the early afternoon. At this time the grass has dried and the newly cut area will not be exposed to the direct sun.
- For best results, adjust the lawn mower cutting height so that the lawn mower cuts off only the top one-third of the grass blades. If the lawn is overgrown it will be necessary to raise the height of cut to reduce pushing effort and to keep from overloading the engine and leaving clumps of mulched grass. For extremely heavy mulching, reduce your width of cut by overlapping previously cut path and mow slowly.
- Certain types of grass and grass conditions may require that an area be mulched a second time to completely hide the clippings. When doing a second cut, mow across or perpendicular to the first cut path.
- Change your cutting pattern from week to week. Mow north to south one week then change to east to west the next week. This will help prevent matting and graining of the lawn.

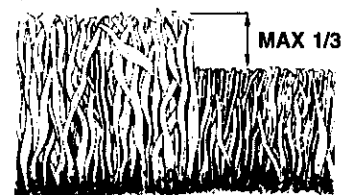

MAINTENANCE

MAINTENANCE SCHEDULE		BEFORE EACH USE AFTER EACH USE EVERY 10 HOURS EVERY 25 HOURS OR EVERY SEASON				BEFORE STORAGE SERVICE DATES			
FILL IN DATES AS YOU COMPLETE REGULAR SERVICE									
M O W E R	Check for Loose Fasteners	✓							
	Clean/Inspect Grass Catcher (If Equipped)	✓	✓						
	Clean Lawn Mower		✓						
	Clean Under Drive Cover (Power-Propelled Mowers)			✓					
	Check drive belt/pulleys (Power-Propelled Mowers)					✓			
	Check/Sharpen/Replace Blade					✓ ₃			
	Lubrication Chart					✓	✓		
E N G I N E	Clean Battery/Recharge (Electric Start Mowers)					✓	✓ ₄		
	Check Engine Oil Level	✓							
	Change Engine Oil					✓ _{1,2}			
	Clean Air Filter					✓ ₂			
	Inspect Muffler					✓			
	Clean or Replace Spark Plug					✓			
Replace Air Filter Paper Cartridge					✓ ₂				

- 1 - Change more often when operating under a heavy load or in high ambient temperatures.
- 2 - Service more often when operating in dirty or dusty conditions.
- 3 - Replace blades more often when mowing in sandy soil.
- 4 - Charge 48 hours at end of season.

GENERAL RECOMMENDATIONS

The warranty on this lawn mower does not cover items that have been subjected to operator abuse or negligence. To receive full value from the warranty, operator must maintain mower as instructed in this manual.

Some adjustments will need to be made periodically to properly maintain your unit.

All adjustments in the Service and Adjustments section of this manual should be checked at least once each season.

- Once a year, replace the spark plug, clean or replace air filter element and check blade for wear. A new spark plug and clean/new air filter element assures proper air-fuel mixture and helps your engine run better and last longer.
- Follow the maintenance schedule in this manual.

BEFORE EACH USE

1. Check engine oil level.
2. Check for loose fasteners.

LUBRICATION

Keep unit well lubricated (See "LUBRICATION CHART").

LUBRICATION CHART

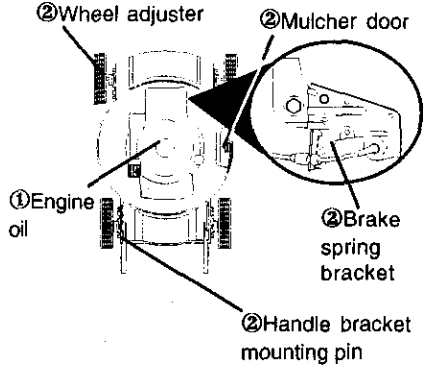

- ① Refer to maintenance "Engine" section.
- ② Spray lubricant

IMPORTANT: Do not oil or grease plastic wheel bearings. viscous lubricants will attract dust and dirt that will shorten the life of the self-lubricating bearings. if you feel they must be lubricated, use only a dry, powdered graphite type lubricant sparingly.

PRODUCT SPECIFICATIONS

SERIAL NUMBER	
DATE OF PURCHASE	
GASOLINE CAPACITY/TYPE:	1.5 QUARTS UNLEADED REGULAR
OIL TYPE (API-S-SJ):	SAE 30 (ABOVE 32°F) SAE 5W-30 (BELOW 32°F)
OIL CAPACITY:	20 OZS.
SPARK PLUG(GAP: .030")	CHAMPION RJ19LM OR J19LM
VALVE CLEARANCE:	INTAKE: .004 - .008 EXHAUST: .004 - .008
SOLID STATE IGNITION	
AIR GAP:	.0125 IN.
BLADE BOLT TORQUE:	35-40 FT. LBS.
<ul style="list-style-type: none"> The model and serial numbers will be found on a decal attached to the rear of the lawn mower housing. Record both serial number and date of purchase in space provided above. 	

LAWN MOWER

Always observe safety rules when performing any maintenance.

TIRES

- Keep tires free of gasoline, oil, or insect control chemicals which can harm rubber.
- Avoid stumps, stones, deep ruts, sharp objects and other hazards that may cause tire damage.

BLADE CARE

For best results, mower blade must be kept sharp. Replace bent or damaged blades.

TO REMOVE BLADE

- Disconnect spark plug wire from spark plug and place wire where it cannot come in contact with spark plug.
- Turn lawn mower on its side. Make sure air filter and carburetor are up.
- Use a wood block between blade and mower housing to prevent blade from turning when removing blade bolt.

NOTE: Protect your hands with gloves and/or wrap blade with heavy cloth.

- Remove blade bolt by turning counter-clockwise.
- Remove blade and attaching hardware (bolt, lock washer and hardened washer).

NOTE: Remove the blade adapter and check the key inside hub of blade adapter. The key must be in good condition to work properly. Replace adapter if damaged.

TO REPLACE BLADE

- Position the blade adapter on the engine crankshaft. Be sure key in adapter and crankshaft keyway are aligned.
 - Position blade on the blade adapter aligning the two (2) holes in the blade with the raised lugs on the adapter.
 - Be sure the trailing edge of blade (opposite sharp edge) is up toward the engine.
 - Install the blade bolt with the lock washer and hardened washer into blade adapter and crankshaft.
 - Use block of wood between blade and lawn mower housing and tighten the blade bolt, turning clockwise.
- The recommended tightening torque is 35-40 ft. lbs.

IMPORTANT: Blade bolt is grade 8 heat treated.

TO SHARPEN BLADE

NOTE: We do not recommend sharpening blade - but if you do, be sure the blade is balanced.

Care should be taken to keep the blade balanced. An unbalanced blade will cause eventual damage to lawn mower or engine.

- The blade can be sharpened with a file or on a grinding wheel. Do not attempt to sharpen while on the mower.

- To check blade balance, drive a nail into a beam or wall. Leave about one inch of the straight nail exposed. Place center hole of blade over the head of the nail. If blade is balanced, it should remain in a horizontal position. If either end of the blade moves downward, sharpen the heavy end until the blade is balanced.

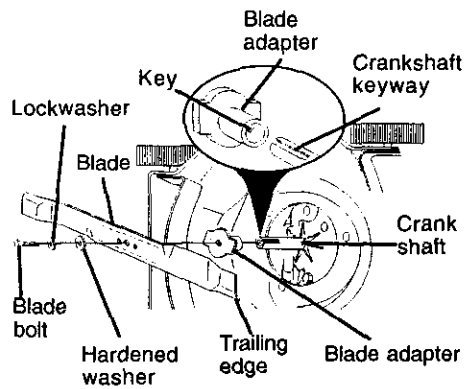

GRASS CATCHER

(If purchased as an accessory)

- The grass catcher may be hosed with water, but must be dry when used.
- Check your grass catcher often for damage or deterioration. Through normal use it will wear. If catcher needs replacing, replace only with a manufacturer approved replacement catcher. Give the lawn mower model number when ordering.

ENGINE

LUBRICATION

Use only high quality detergent oil rated with API service classification SF-SJ. Select the oil's SAE viscosity grade according to your expected operating temperature.

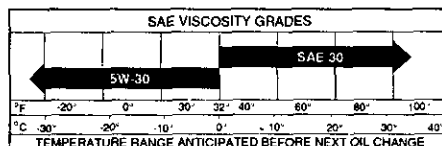

NOTE: Although multi-viscosity oils (5W30, 10W30 etc.) improve starting in cold weather, these multi-viscosity oils will result in increased oil consumption when used above 32°F. Check your engine oil level more frequently to avoid possible engine damage from running low on oil.

Change the oil after every 25 hours of operation or at least once a year if the lawn mower is not used for 25 hours in one year.

Check the crankcase oil level before starting the engine and after each five (5) hours of continuous use. Tighten oil plug securely each time you check the oil level.

TO CHANGE ENGINE OIL

NOTE: Before tipping lawn mower to drain oil, drain fuel tank by running engine until fuel tank is empty.

- Disconnect spark plug wire from spark plug and place wire where it cannot come in contact with spark plug.
- Remove engine oil cap; lay aside on a clean surface.
- Tip lawn mower on its side as shown and drain oil into a suitable container. Rock lawn mower back and forth to remove any oil trapped inside of engine.
- Wipe off any spilled oil on lawn mower and on side of engine.
- Fill engine with oil. (See "Add Oil" in the Operation section of this manual.)
- Reconnect spark plug wire to spark plug.

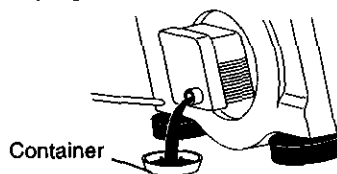

AIR FILTER

Your engine will not run properly and may be damaged by using a dirty air filter. Replace the air filter every year, more often if you mow in very dusty, dirty conditions. Do not wash air filter.

TO CHANGE AIR FILTER

1. Remove the air filter by turning counterclockwise to the stop and pull away from collar.
2. Remove filter from inside of cover.
3. Clean the inside of the cover and the collar to remove any dirt accumulation.
4. Insert new filter into cover.
5. Put air filter cover and filter into collar aligning the tab with the slot.
6. Push in on cover and turn clockwise to tighten.

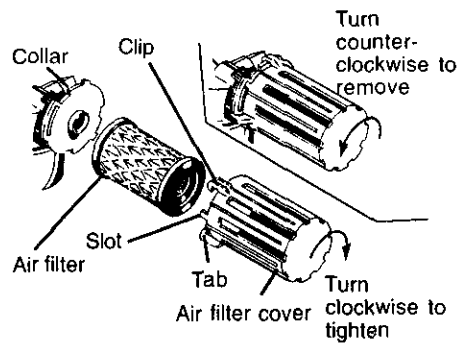

MUFFLER

Inspect and replace corroded muffler as it could create a fire hazard and/or damage.

SPARK PLUG

Change your spark plug each year to make your engine start easier and run better. Set spark plug gap at .030 inch.

CLEANING

IMPORTANT: For best performance, keep mower housing free of built-up grass and trash. Clean the underside of your mower after each use.

CAUTION: Disconnect spark plug wire from spark plug and place wire where it cannot come in contact with the spark plug.

- Clean the underside of your lawn mower by scraping to remove build-up of grass and trash.
- Clean engine often to keep trash from accumulating. A clogged engine runs hotter and shortens engine life.
- Keep finished surfaces and wheels free of all gasoline, oil, etc.
- We do not recommend using a garden hose to clean lawn mower unless the electrical system, muffler, air filter and carburetor are covered to keep water out. Water in engine can result in shortened engine life.

SERVICE AND ADJUSTMENTS

CAUTION: Before performing any service or adjustments:

1. Release control bar and stop engine.
2. Make sure the blade and all moving parts have completely stopped.
3. Disconnect spark plug wire from spark plug and place where it cannot come in contact with plug.

LAWN MOWER

TO ADJUST CUTTING HEIGHT

See "TO ADJUST CUTTING HEIGHT" in the Operation section of this manual.

REAR DEFLECTOR

The rear deflector, attached between the rear wheels of your mower, is provided to minimize the possibility that objects will be thrown out of the rear of the mower into the operator's mowing position. If the deflector becomes damaged, it should be replaced.

DISCHARGE GUARD

The discharge guard, attached to the discharge opening of your lawn mower, is provided to prevent the possibility of injury resulting from objects being thrown out of the discharge opening into the operator mowing position. If the discharge guard becomes damaged, it should be replaced.

TO ADJUST HANDLE

The handle can be mounted in a high or low position. The mounting holes in the bottom of lower handle are off center for raising or lowering the handle.

1. Remove upper handle and all parts attached to lower handle.
2. Remove hairpin cotters from lower handle bracket mounting pin.
3. Squeeze lower handle in to remove it from mounting pins.
4. Turn lower handle over to raise or lower handle.
5. Squeeze lower handle in and position holes onto mounting pins on handle bracket.
6. Reassemble upper handle and all parts removed from lower handle.

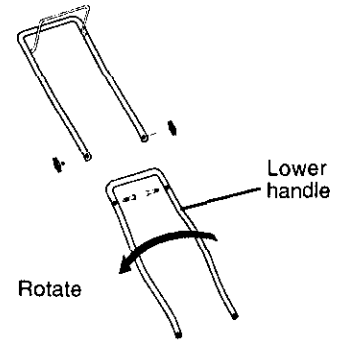

ENGINE

ENGINE SPEED

Your engine speed has been factory set. Do not attempt to increase engine speed or it may result in personal injury. If you believe that the engine is running too fast or too slow, take your lawn mower to an authorized service center for repair and adjustment.

CARBURETOR

Your carburetor has a non-adjustable fixed main jet for mixture control. If your engine does not operate properly due to suspected carburetor problems, take your lawn mower to an authorized service center for repair and/or adjustment.

IMPORTANT: Never tamper with the engine governor, which is factory set for proper engine speed. Overspeeding the engine above the factory high speed setting can be dangerous. If you think the engine-governed high speed needs adjusting, contact your nearest authorized service center, which has proper equipment and experience to make any necessary adjustments.

STORAGE

Immediately prepare your lawn mower for storage at the end of the season or if the unit will not be used for 30 days or more.

LAWN MOWER

When lawn mower is to be stored for a period of time, clean it thoroughly, remove all dirt, grease, leaves, etc. Store in a clean, dry area.

1. Clean entire lawn mower (See "CLEANING" in the Maintenance section of this manual).
2. Lubricate as shown in the Maintenance section of this manual.
3. Be sure that all nuts, bolts, screws, and pins are securely fastened. Inspect moving parts for damage, breakage and wear. Replace if necessary.
4. Touch up all rusted or chipped paint surfaces; sand lightly before painting.

HANDLE

You can fold your lawn mower handle for storage.

1. Squeeze the bottom ends of the lower handle toward each other until the lower handle clears the handle bracket, then move handle forward.
2. Loosen upper handle mounting bolts enough to allow upper handle to be folded back.

IMPORTANT: When folding the handle for storage or transportation, be sure to fold the handle as shown or you may damage the control cables.

- When setting up your handle from the storage position, the lower handle will automatically lock into the mowing position.

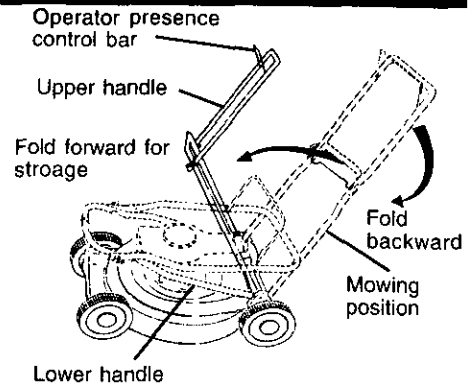
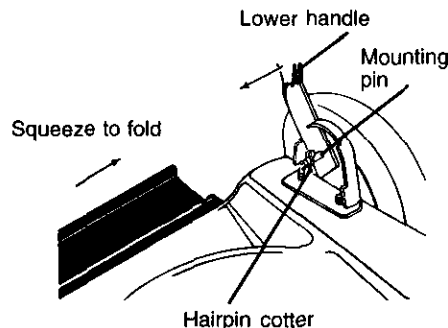

ENGINE

FUEL SYSTEM

IMPORTANT: It is important to prevent gum deposits from forming in essential fuel system parts such as carburetor, fuel filter, fuel hose, or tank during storage. Also, experience indicates that alcohol blended fuels (called gasohol or using ethanol or methanol) can attract moisture which leads to separation and formation of acids during storage. Acidic gas can damage the fuel system of an engine while in storage.

1. Drain the fuel tank.
 2. Start the engine and let it run until the fuel lines and carburetor are empty.
- Never use engine or carburetor cleaner products in the fuel tank or permanent damage may occur.
 - Use fresh fuel next season.

NOTE: Fuel stabilizer is an acceptable alternative in minimizing the formation of fuel gum deposits during storage. Add stabilizer to gasoline in fuel tank or storage container. Always follow the mix ratio found on stabilizer container. Run engine at least 10 minutes after adding stabilizer to allow the stabilizer to reach the carburetor. Do not drain the gas tank and carburetor if using fuel stabilizer.

ENGINE OIL

Drain oil (with engine warm) and replace with clean engine oil. (See "ENGINE" in the Maintenance section of this manual).

CYLINDER

1. Remove spark plug.
2. Pour one ounce (29 ml) of oil through spark plug hole into cylinder.
3. Pull starter handle slowly a few times to distribute oil.
4. Replace with new spark plug.

OTHER

- Do not store gasoline from one season to another.
- Replace your gasoline can if your can starts to rust. Rust and/or dirt in your gasoline will cause problems.
- If possible, store your unit indoors and cover it to give protection from dust and dirt.

- Cover your unit with a suitable protective cover that does not retain moisture. Do not use plastic. Plastic cannot breathe which allows condensation to form and will cause your unit to rust.
- IMPORTANT:** Never cover mower while engine and exhaust areas are still warm.
- ⚠ CAUTION:** Never store the lawn mower with gasoline in the tank inside a building where fumes may reach an open flame or spark. Allow the engine to cool before storing in any enclosure.

TROUBLESHOOTING CHART

PROBLEM	CAUSE	CORRECTION
Does not start	<ol style="list-style-type: none"> 1. Dirty air filter. 2. Out of fuel. 3. Stale fuel. 4. Water in fuel. 5. Spark plug wire is disconnected. 6. Bad spark plug. 7. Loose blade or broken blade adapter. 8. Control bar in released position. 9. Control bar defective. 	<ol style="list-style-type: none"> 1. Clean/replace air filter. 2. Fill fuel tank. 3. Drain tank and refill with fresh clean fuel. 4. Drain fuel tank and carburetor and refill tank with fresh gasoline. 5. Connect wire to plug. 6. Replace spark plug. 7. Tighten blade bolt or replace blade adapter. 8. Depress control bar to handle. 9. Replace control bar.
Loss of power	<ol style="list-style-type: none"> 1. Rear of lawn mower housing or cutting blade dragging in heavy grass. 2. Cutting too much grass. 3. Dirty air filter. 4. Buildup of grass, leaves, and trash under mower. 5. Too much oil in engine. 6. Walking speed too fast. 	<ol style="list-style-type: none"> 1. Set to "Higher Cut" position. 2. Set to "Higher Cut" position. 3. Clean/replace air filter. 4. Clean underside of mower housing. 5. Check oil level. 6. Cut at slower walking speed.
Poor cut – uneven	<ol style="list-style-type: none"> 1. Worn, bent or loose blade. 2. Wheel heights uneven. 3. Buildup of grass, leaves and trash under mower. 	<ol style="list-style-type: none"> 1. Replace blade. Tighten blade bolt. 2. Set all wheels at same height 3. Clean underside of mower housing.
Excessive vibration	<ol style="list-style-type: none"> 1. Worn, bent or loose blade. 2. Bent engine crankshaft. 	<ol style="list-style-type: none"> 1. Replace blade. Tighten blade bolt. 2. Contact a qualified service center.

TROUBLESHOOTING CHART

PROBLEM	CAUSE	CORRECTION
Starter rope hard to pull	<ol style="list-style-type: none">1. Engine flywheel brake is on when control bar is released2. Bent engine crankshaft.3. Blade adapter broken.4. Blade dragging in grass.	<ol style="list-style-type: none">1. Depress control bar to upper handle before pulling starter rope.2. Contact a qualified service center.3. Replace blade adapter.4. Move lawn mower to cut grass or to hard surface.
Grass catcher not filling (if so equipped)	<ol style="list-style-type: none">1. Cutting height too low.2. Lift on blade worn off.3. Catcher not venting air.	<ol style="list-style-type: none">1. Raise cutting height.2. Replace blade.3. Clean grass catcher.
Hard to push	<ol style="list-style-type: none">1. Grass is too high or wheel height is too low.2. Rear of lawn mower housing or blade dragging in grass.3. Grass catcher too full.4. Handle height position not right for you.	<ol style="list-style-type: none">1. Raise cutting height.2. Raise rear of lawn mower housing one (1) setting higher.3. Empty grass catcher.4. Adjust handle height to suit.

ROTARY LAWN MOWER - MODEL NO. 917.387441

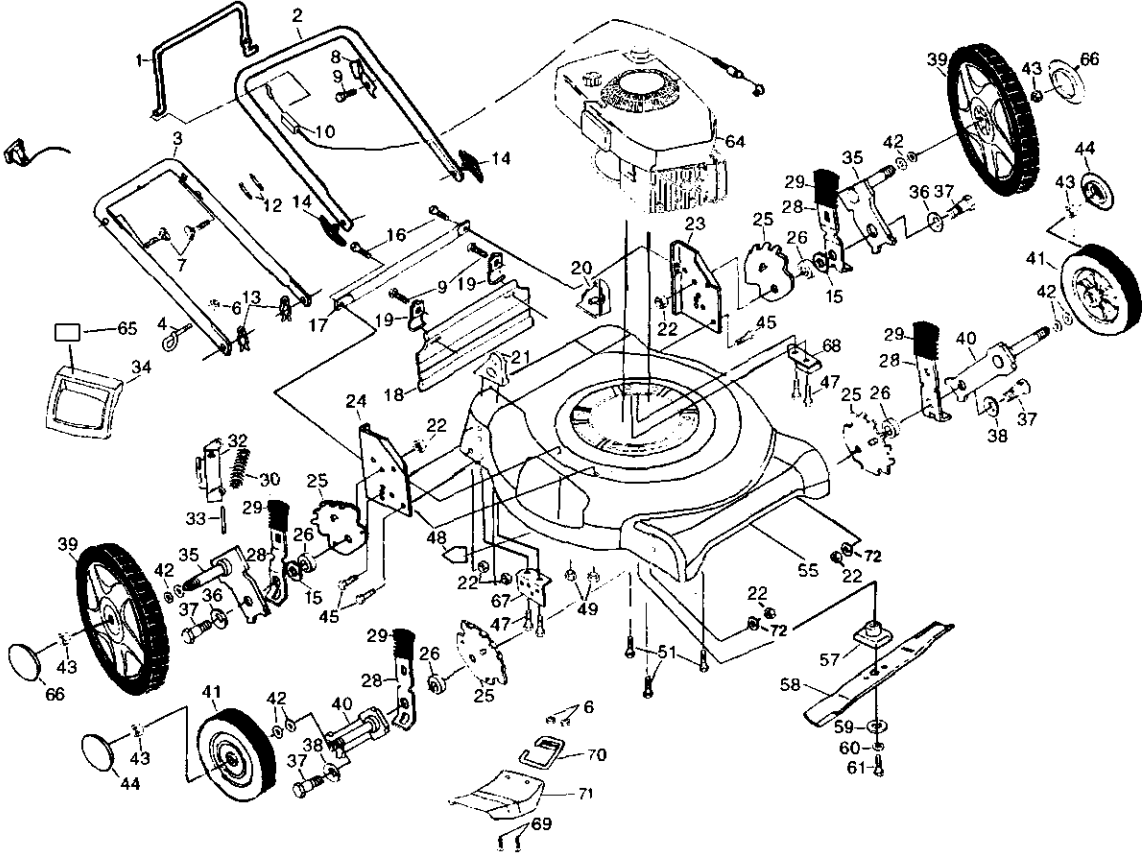

34

ROTARY LAWN MOWER - MODEL NO. 917.387441

KEY NO.	PART NO	DESCRIPTION	KEY NO.	PART NO	DESCRIPTION
1	131696	Control Bar	41	150348	Wheel & Tire Assembly (Front)
2	166860X479	Upper Handle	42	57143	Wave Washer
3	151590X479	Lower Handle	43	83923	Locknut 3/8-16
4	153638	Rope Guide	44	150182	Hubcap
6	63601	Locknut 1/4-20	45	74760612	Hex Head Bolt 3/8-16 x 3/4
7	131959	Handle Bolt	47	149741	Screw 5/16-18 x 3/4
8	850733X004	Up-Stop Bracket	48	85463	Danger Decal
9	750097	Hex Thread Rolling Screw #10-24 x 3/4	49	STD541425	Locknut 1/4-20
10	175604	Engine Zone Control Cable	51	150406	Hex Head Thread Rolling Screw 3/8-16 x 1
12	66426	Wire Tie	55	170348	Lawn Mower Housing (Incl. Ref. #20, 47, 48, 53, 54)
13	51793	Hairpin Cotter	57	851514	Blade Adapter
14	136376	Handle Knob	58	152202	22" Blade
15	88348	Flat Washer 3/8	59	851074	Washer
16	STD512505	Hex Head Self Tapping Screw 1/4-20 x 1/2	60	850263	Helical Hardened Lockwasher 3/8
17	165175X479	Support Rod	61	851084	Hex Head Machine Screw 3/8-24 x 1/4 Grd. 8
18	140540	Rear Deflector	64	-----	Engine - (See Breakdown) Craftsman Model 143.006200
19	87584X004	Deflector Bracket	66	151440	Hubcap
20	170346X479	Handle Bracket Assembly (Left)	67	153350x479	Bracket Support Handle (Right)
21	170345X479	Handle Bracket Assembly (Right)	68	153282x479	Bracket Support Handle (Left)
22	751592	Locknut 3/8-16	69	74180410	Screw
23	700168X479	Support Bracket (Left)	70	751399	Bracket
24	700166X479	Support Bracket (Right)	71	752118	Clipping Deflector
25	700325X007	Wheel Adjuster Bracket	72	61537	Washer
26	146630	Spacer	--	161058	Warning Decal
28	700331X004	Selector Spring	--	175408	Owner's Manual (English/Spanish)
29	701037	Selector Knob	Available accessories not included with lawn mower:		
30	152124	Torsion Spring	71	33072	Grass Catcher
32	154132	Housing Bracket Assembly	71	33623	Gas Can (2.5 gal.)
33	147286	Hinge Rod	71	33500	Fuel Stabilizer
34	151889	Discharge Guard	71	33000	SAE 30W Oil (20 oz.)
35	750913X004	Axle Arm Assembly (Rear)	71	33316	Mower Cover
36	61651	Spring Washer (Rear)			
37	142748	Shoulder Bolt 3/8-16			
38	62335	Belleville Washer			
39	151138	Wheel & Tire Assembly (Rear)			
40	145935X004	Axle Arm Assembly			

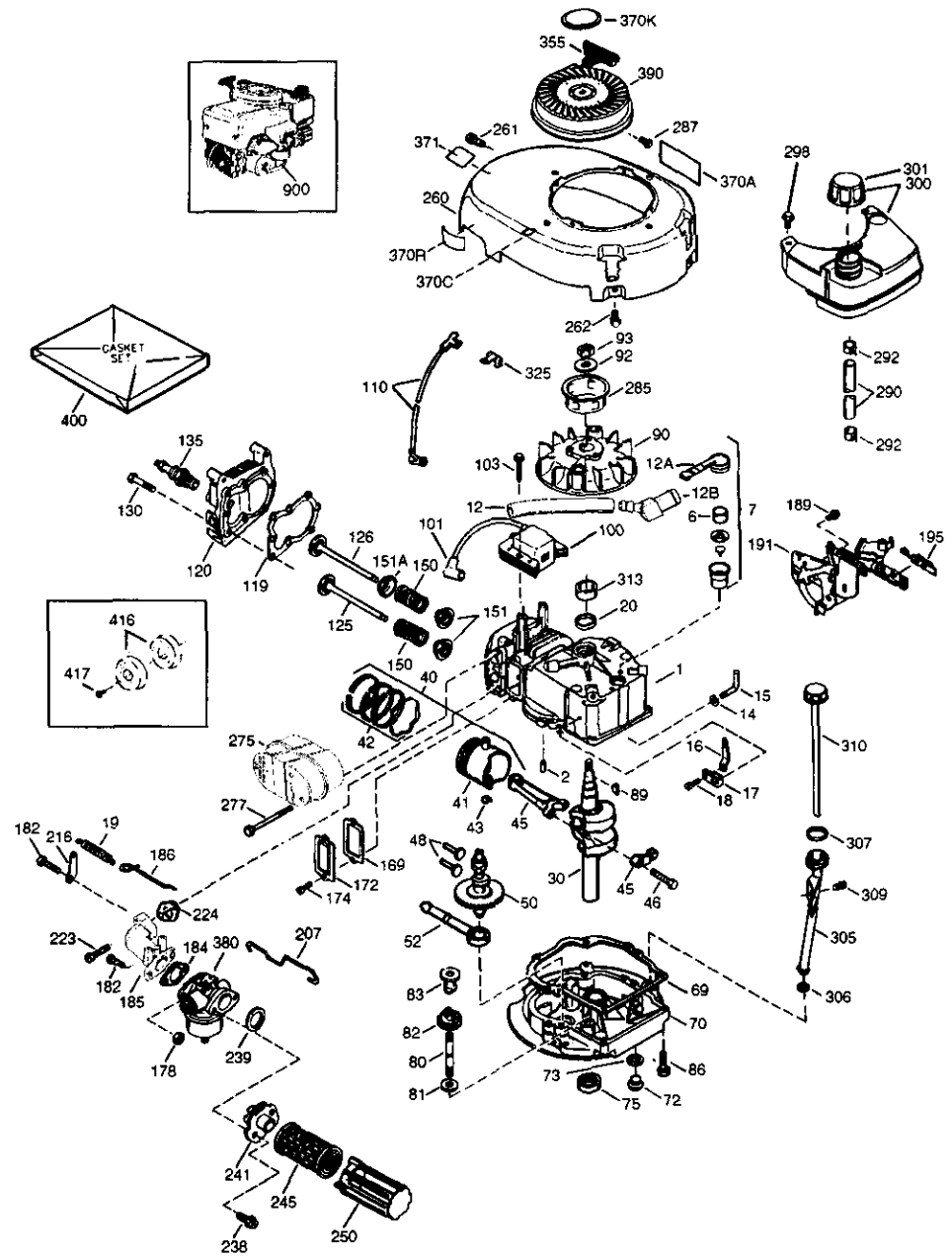

KEY NO.	PART NO.	DESCRIPTION	KEY NO.	PART NO.	DESCRIPTION
1	37266	Cylinder (Incl. 2,20 & 150)	169	36783	* Valve Cover Gasket
2	26727	Dowel Pin	172	36784	Valve Cover
6	33734	Breather Element	174	30200	Screw, 10-24 x 9/16"
7	36557	Breather Ass'y. (Incl. 6 & 12A)	178	29752	Nut & Lock Washer, 1/4-28
12	36775	Breather Tube	182	6201	Screw, 1/4-28 x 7/8"
12A	36558	Breather Cover & Tube (Incl. 12B)	184	26756	* Carburetor To Intake
12B	36694	Breather Tube Elbow			Pipe Gasket
14	28277	Washer	185	36785	Intake Pipe
15	30589	Governor Rod (Incl. 14)	186	32653	Governor Link
16	34839A	Governor Lever	189	650839	Screw, 1/4-20 x 3/8"
17	31335	Governor Lever Clamp	191	36559A	S.E. Brake Bracket (Incl. 195)
18	651018	Screw, Torx T-15, 8-32 x 19/64"	195	610973	Terminal
		Extension Spring	207	34336	Throttle Link
19	36281	Oil Seal	216	33086	R.P.M. Adjusting Lever
20	32600	Crankshaft	223	650451	Screw, 1/4-20 x 1"
30	36776	Piston, Pin & Ring Set (Std.)	224	36786	* Intake Pipe Gasket
40	40004	Piston, Pin & Ring Set (.010" OS)	238	650932	Screw, 10-32 x 49/64"
	40005	Piston & Pin Ass'y. (Std.) (Incl. 43)	239	34338	* Air Cleaner Gasket
41	36070	Piston & Pin Ass'y. (.010" OS)(Incl. 43)	241	35797	Air Cleaner Collar
	36071	Ring Set (Std.)	245	35066	Air Cleaner Filter
		Ring Set (.010" OS)	250	35065	Air Cleaner Cover
42	40006	Piston Pin Retaining Ring	260	36980	Blower Housing
	40007	Connecting Rod Ass'y. (Incl. 46)	261	30200	Screw, 10-24 x 9/16"
43	20381	Connecting Rod Bolt	262	650831	Screw, 1/4-20 x 1/2"
45	36777	Valve Lifter	275	36790A	Muffler
		Camshaft (MCR)	277	650988	Screw, 1/4-20 x 2-5/16"
46	32610A	Oil Pump Ass'y.	285	35000A	Starter Cup
48	27241	* Mounting Flange Gasket	287	650926	Screw, 8-32 x 21/64"
50	37460	Mounting Flange (Incl. 72 thru 83,306)	290	29774	Fuel Line
52	29914	Oil Drain Plug (Incl. 73)	292	26460	Fuel Line Clamp
69	35261	Drain Plug Gasket	298	28763	Screw, 10-32 x 35/64"
70	34311E	Oil Seal	300	36916	Fuel Tank (Incl. 292 & 301)
		Washer	301	36246	Fuel Cap
72	30572	Governor Shaft	305	35647	Oil Fill Tube
73	28833	Governor Gear Ass'y. (Incl. 81)	306	36996	* "O"-Ring
75	27897	Governor Spool	307	35499	"O"-Ring
80	30574A	Screw, 1/4-20 x 1-1/4"	309	650562	Screw, 10-32 x 1/2"
81	30590A	Flywheel Key	310	35648	Dipstick
82	30591	Flywheel	313	34080	Spacer
		Belleville Washer	325	37152	Spring Clip
83	30588A	Flywheel Nut	355	590701	Starter Handle (Black)
86	650488	Solid State Ignition	370A	36261	Identification Decal
89	611004	Spark Plug Cover	370C	37318	Primer Decal (3 X)
90	611112	Screw, Torx T-15, 10-24 x 15/16"	370K	36695	Starter Decal
92	650815	Ground Wire	370R	37317	Warning Decal
93	650816	* Cylinder Head Gasket	371	37269	6.5 H.P. Craftsman Decal
100	34443B	Cylinder Head	380	640262	Carburetor (Incl. 184)
101	610118	Exhaust Valve (Std.) (Incl. 151)	390	590737	Rewind Starter
103	651007	Intake Valve (Std.) (Incl. 151)	400	36792B	Gasket Set (Incl. Items Marked *)
		Screw, 5/16-18 x 1-1/2"	416	36085	Spark Arrestor Kit (Incl. 417)(Optional)
110	37047	Resistor Spark Plug (RJ19LM)	417	650821	Screw, 10-32 x 1/2" (Optional)
119	36787	Valve Spring	900	---	Replacement Engine NONE
120	36825	Valve Spring Cap	900	---	Replacement S/B 750860, order from 71-999
125	37288	Intake Valve Seal	---	---	RPM High 2900 to 3200
126	37289				
130	6021A				
135	35395				
150	31672				
151	31673				
151A	40017				

NOTE: This engine could have been built with 590694 starter).

NOTE: All component dimensions given in U.S. inches 1 inch = 25.4 mm

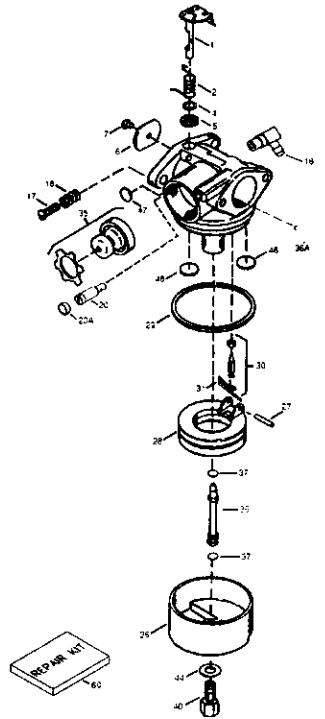

KEY NO.	PART NO.	DESCRIPTION
—	640262	Carburetor (Incl. 184 of Engine Parts List)
1	631615	Throttle Shaft & Lever Assembly
2	631767	Throttle Return Spring
4	631184	* Dust Seal Washer
5	631183	* Dust Seal (Throttle)
6	640070	Throttle Shutter
7	650506	* Shutter Screw
16	631807	Fuel Fitting
17	651025	Throttle Crack Screw/Idle Speed Screw
18	630766	Tension Spring
20	640018	Idle Restrictor Screw
20A	640200	Idle Restrictor Screw Cap (Black)
25	631867	Float Bowl
27	631024	* Float Shaft
28	632019	Float
29	631028	* Float Bowl "O" Ring
30	631021	* Inlet Needle, Seat, & Clip (Incl. 31)
31	631022	Spring Clip
35	640259	Primer Bulb/Retainer Ring
36	640080	Main Nozzle Tube
36A	632766	Carburetor Tube
37	632547	* "O" Ring, Main Nozzle Tube
40	640175	High Speed Bowl Nut
44	27110A	* Bowl Nut Washer
47	630748	* Welch Plug, Idle Mixture Well
48	631027	* Welch Plug, Atmospheric Vent
60	632760B	Repair kit (Incl. Items Marked *)

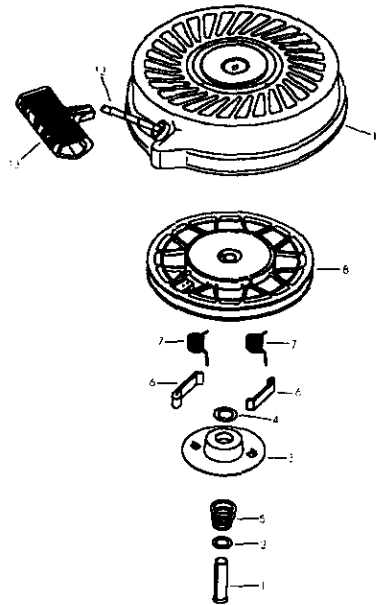

KEY NO.	PART NO.	DESCRIPTION
—	590694	Recoil Starter
1	590599A	Spring Pin (Incl. 4)
2	590600	Washer
3	590696	Retainer
4	590601	Washer
5	590697	Brake Spring
6	590698	Starter Dog
7	590699	Dog Spring
8	590700	Pulley & Rewind Spring Ass'y.
11	590695	Starter Housing Ass'y. (40 degree grommet)
12	590535	Starter Rope (98" X 9/64" dia.)
13	590701	Starter Handle

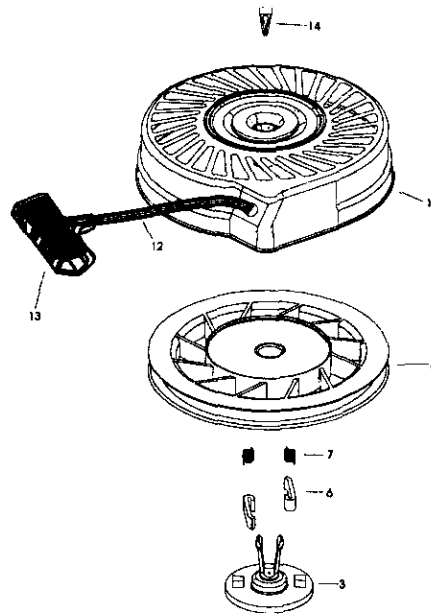

KEY NO.	PART NO.	DESCRIPTION
—	590737	Rewind Starter
3	590740	Retainer
6	590616	Starter Dog
7	590617	Dog Spring
8	590618A	Pulley & Rewind Spring Ass'y
11	590687A	Starter Housing Ass'y (40 degree grommet)
12	590535	Starter Rope (Length 98" x 9/64" dia.)
13	590701	Starter Handle
14	590760	Spring Clip

Get it fixed, at your home or ours!

For repair of major brand appliances **in your own home...**
no matter who made it, no matter who sold it!

1-800-4-MY-HOMESM Anytime, day or night
(1-800-469-4663)

www.sears.com

To bring in products such as vacuums,
lawn equipment and electronics for repair, call for
the location of your nearest **Sears Parts & Repair Center.**

1-800-488-1222 Anytime, day or night

www.sears.com

For the replacement parts, accessories and owner's manuals
that you need to do-it-yourself, call **Sears PartsDirect**SM!

1-800-366-PART 6 a.m. – 11 p.m. CST,
(1-800-366-7278) 7 days a week

www.sears.com/partsdirect

To purchase or inquire about a Sears Service Agreement:

1-800-827-6655

7 a.m. – 5 p.m. CST, Mon. – Sat.

Para pedir servicio de reparación a domicilio,
y para ordenar piezas con entrega a domicilio:

1-888-SU-HOGARSM
(1-888-784-6427)

Au Canada pour service en français:

1-877-LE-FOYERSM
(1-877-533-6937)



© Sears, Roebuck and Co.

® Registered Trademark / ™ Trademark of Sears, Roebuck and Co.
® Marca Registrada / ™ Marca de Fábrica de Sears, Roebuck and Co.

175408 09.13.00 VB

Printed in U.S.A.