

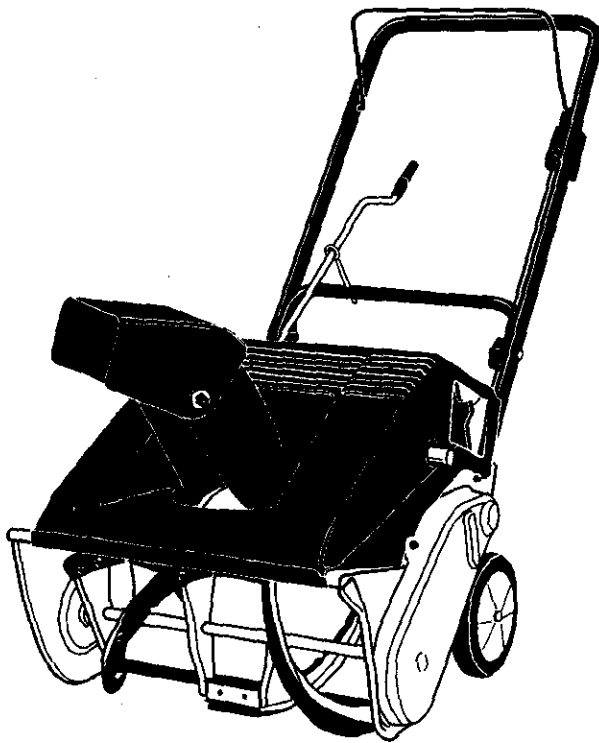

Operators Manual



Model 150 shown

**Model Series
140 thru E173
Single Stage
Snow Throwers**



IMPORTANT: READ SAFETY RULES AND INSTRUCTIONS CAREFULLY

Warning: This unit is equipped with an internal combustion engine and should not be used on or near any unimproved forest-covered, brush-covered or grass-covered land unless the engine's exhaust system is equipped with a spark arrester meeting applicable local or state laws (if any). If a spark arrester is used, it should be maintained in effective working order by the operator. In the State of California the above is required by law (Section 4442 of the California Public Resources Code). Other states may have similar laws. Federal laws apply on federal lands. A spark arrester for the muffler is available through your nearest engine authorized service dealer or contact the service department, P.O. Box 368022 Cleveland, Ohio 44136-9722.

MTD PRODUCTS INC. P.O. BOX 368022 CLEVELAND, OHIO 44136-9722

SECTION 1: IMPORTANT SAFE OPERATION PRACTICES



WARNING: THIS SYMBOL POINTS OUT IMPORTANT SAFETY INSTRUCTIONS WHICH, IF NOT FOLLOWED, COULD ENDANGER THE PERSONAL SAFETY AND/OR PROPERTY OF YOURSELF AND OTHERS. READ AND FOLLOW ALL INSTRUCTIONS IN THIS MANUAL BEFORE ATTEMPTING TO OPERATE YOUR SNOW THROWER. FAILURE TO COMPLY WITH THESE INSTRUCTIONS MAY RESULT IN PERSONAL INJURY. WHEN YOU SEE THIS SYMBOL-HEED ITS WARNING.



WARNING: The Engine Exhaust from this product contains chemicals known to the State of California to cause cancer, birth defects or other reproductive harm.



DANGER: Your snow thrower was built to be operated according to the rules for safe operation in this manual. As with any type of power equipment, carelessness or error on the part of the operator can result in serious injury. If you violate any of these rules, you may cause serious injury to yourself or others.

1. TRAINING

- Read this operator's manual carefully in its entirety before attempting to assemble or operate this machine. Be completely familiar with the controls and the proper use of this machine before operating it. Keep this manual in a safe place for future and regular reference and for ordering replacement parts.
- Never allow children under 14 years old to operate a snow thrower. Children 14 years old and over should only operate snow thrower under close parental supervision. Only persons well acquainted with these rules of safe operation should be allowed to use your snow thrower.
- No one should operate this unit while intoxicated or while taking medication that impairs the senses or reactions.
- Keep the area of operation clear of all persons, especially small children and pets.
- Exercise caution to avoid slipping or falling, especially when operating in reverse.
- Before working with gasoline, extinguish all cigarettes and other sources of ignition. Check the fuel before starting the engine. Gasoline is an extremely flammable fuel. Do not fill the gasoline tank indoors, while the engine is running, or until engine has been allowed to cool at least two minutes. Replace gasoline cap securely and wipe off any spilled gasoline before starting the engine as it may cause a fire or explosion.
- Use a grounded three wire plug-in for all units with electric drive motors or electric starting motors.
- Adjust collector housing height to clear gravel or crushed rock surface.
- Never attempt to make any adjustments while engine is running (except where specifically recommended by manufacturer).
- Let engine and machine adjust to outdoor temperature before starting to clear snow.
- Always wear safety glasses or eye shields during operation or while performing an adjustment or repair, to protect eyes from foreign objects that may be thrown from the machine in any direction.

1. PREPARATION

- Thoroughly inspect the area where the equipment is to be used and remove all door mats, sleds, boards, wires and other foreign objects.
- Disengage all clutches and shift into neutral before starting engine.
- Do not operate equipment without wearing adequate winter outer garments. Do not wear jewelry, long scarfs or other loose clothing which could become entangled in moving parts. Wear footwear which will improve footing on slippery surfaces.

2. OPERATION

- Do not put hands or feet near or under rotating parts. Keep clear of discharge opening and auger at all times.
- Exercise extreme caution when operating on or crossing gravel drives, walks, or roads. Stay alert for hidden hazards or traffic. Do not carry passengers.
- After striking a foreign object, stop the engine, remove wire from spark plug, and thoroughly inspect the snow thrower for any damage. Repair the damage before restarting and operating the snow thrower.

- If the snow thrower should start to vibrate abnormally, stop the engine and check immediately for the cause. Vibration is generally a warning of trouble.
- Stop engine whenever you leave the operating position, before unclogging the collector/impeller housing or discharge guide, and making any repairs, adjustments, or inspections. Never place your hand in the discharge or collector openings. Use a stick or wooden broom handle to unclog the discharge opening.
- Take all possible precautions when leaving the unit unattended. Disengage the collector/impeller, shift into neutral, stop the engine, and remove the key.
- When cleaning, repairing, or inspecting, make certain collector/impeller and all moving parts have stopped. Disconnect spark plug wire and keep away from plug to prevent accidental starting.
- Do not run engine indoors, except when starting engine and transporting snow thrower in or out of building. Open doors. Exhaust fumes are dangerous.
- Do not clear snow across the face of slopes. Exercise extreme caution when changing direction on slopes. Do not attempt to clear steep slopes.
- Never operate snow thrower without guards, plates, or other safety protection devices in place.
- Never operate snow thrower near glass enclosure, automobiles, window wells, drop off, etc., without proper adjustments of snow thrower discharge angle. Keep children and pets away.
- Do not overload machine capacity by attempting to clear snow at too fast a rate.
- Never operate the machine at high transport speeds on slippery surfaces. Look behind and use care when backing.

- Never direct discharge at bystanders or allow anyone in front of unit.
- Disengage power to collector/impeller when transporting or not in use.
- Use only attachments and accessories approved by the manufacturer of snow thrower (such as wheel weights, counter weights, cabs, etc.).
- Never operate the snow thrower without good visibility or light. Always be sure of your footing and keep a firm hold on the handles. Walk, never run.
- Muffler and engine become hot and can cause a burn. Do not touch.

3. MAINTENANCE AND STORAGE

- Check shear bolts, engine mounting bolts, etc., at frequent intervals for proper tightness to be sure equipment is in safe working condition.
- Never store the machine with fuel in the fuel tank inside a building where ignition sources are present, such as hot water and space heaters, clothes dryers, and the like. Allow engine to cool before storing in any enclosure.
- Always refer to operator's manual instructions for important details if snow thrower is to be stored for an extended period.
- Run machine a few minutes after throwing snow to prevent freeze up of collector/impeller.
- Check clutch controls periodically to verify they engage and disengage properly and readjust if necessary. Refer to operator's manual for adjustment instructions.



WARNING - YOUR RESPONSIBILITY: Restrict the use of this power machine to persons who read, understand and follow the warnings and instructions in this manual and on the machine.



Figure 1

SECTION 2: FINDING YOUR MODEL NUMBER

This Operator's Manual is an important part of your new snow thrower. It will help you assemble, prepare and maintain your snow thrower. Please read and understand what it says.

Before you start to prepare your snow thrower for its first use, please locate the model plate and copy the information from it in this Operator's Manual. The information on the model plate is very important if you need help from your dealer or the MTD customer support department.

- Every snow thrower has a model plate. You can locate it by standing behind the unit in the operating position and looking down at the dash panel.
- The model plate will look like Figure 2.

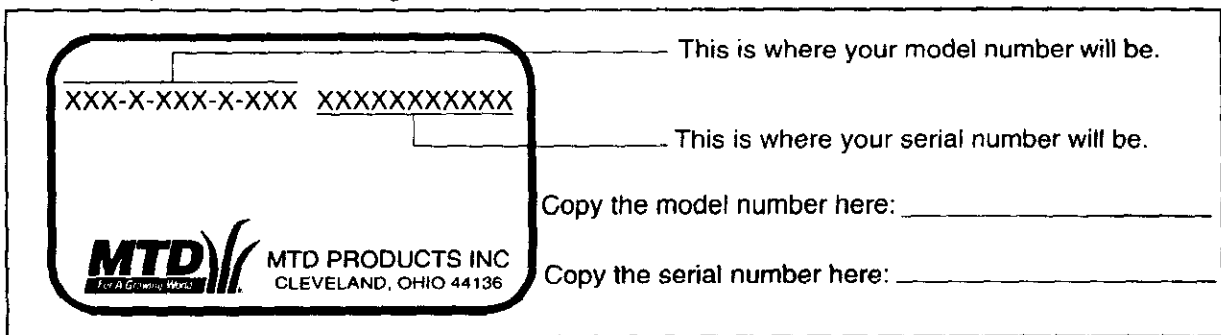

Figure 2

SECTION 3: CALLING CUSTOMER SUPPORT

If you are having difficulty assembling this product or if you have any question regarding the controls, operation or maintenance of this snow thrower, please call the Customer Support Department. You can reach them by calling:

1-800-800-7310

Before you call, make sure that you have both your model and serial number ready. By having the model and serial number ready, you help the Customer Support Representative give you faster service. To find your units model and serial number, see SECTION 2: FINDING YOUR MODEL NUMBER.

SECTION 4: UNPACKING INSTRUCTIONS

- See Figure 3.
- Remove staples, break glue on the top flaps of the carton or cut tape at carton end and peel along top flap to open carton. Remove any loose parts included with unit (i.e., Operator's manual, etc.).
- Cut along dotted lines and lay end of carton down flat. Remove packing material.
- Roll unit out of carton. Check carton thoroughly for loose parts.

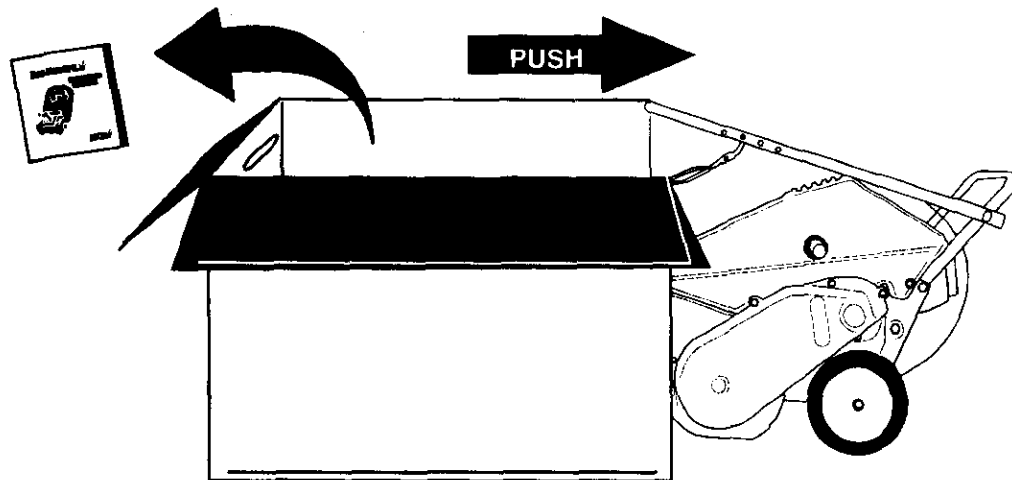

REMOVE MANUAL & LOOSE PARTS

Figure 3

SECTION 5: SET-UP INSTRUCTIONS

This Operator's Manual covers several models of snow throwers. Much of the Manual pertains to all of the models. However, there are some areas where only one model is covered. Use only the information that is appropriate for your model.

ITEMS REQUIRED FOR SET-UP

- Pair of pliers (not necessary, but helpful)
- 2 cycle oil
- Fresh Gasoline

IMPORTANT: This unit is shipped WITHOUT GASOLINE or OIL. See separate Engine Operator's Manual for proper fuel and two cycle engine oil recommendations.

Note: Reference to right or left hand side of the snow thrower is from the operating position

CONTENTS OF HARDWARE PACK

- (2) Ignition Keys (One may be in the switch on snow thrower)

Models with Optional Extended Chute Crank:

- (1) Eyebolt
- (1) Saddle Washer 5/16" I.D.
- (2) Hex Nuts 5/16-18 Thread
- (1) Cotter Pin

RAISING THE UPPER HANDLE

1. Loosen the hand knob on each side of the handle. See Figure 4. Remove packing material (if any).
2. Squeeze the control handle against the upper handle. Hold it in this position as you raise the handle.
3. Pull the handle up into the operating position. Be certain not to pinch the cable.
4. Tighten the hand knobs.

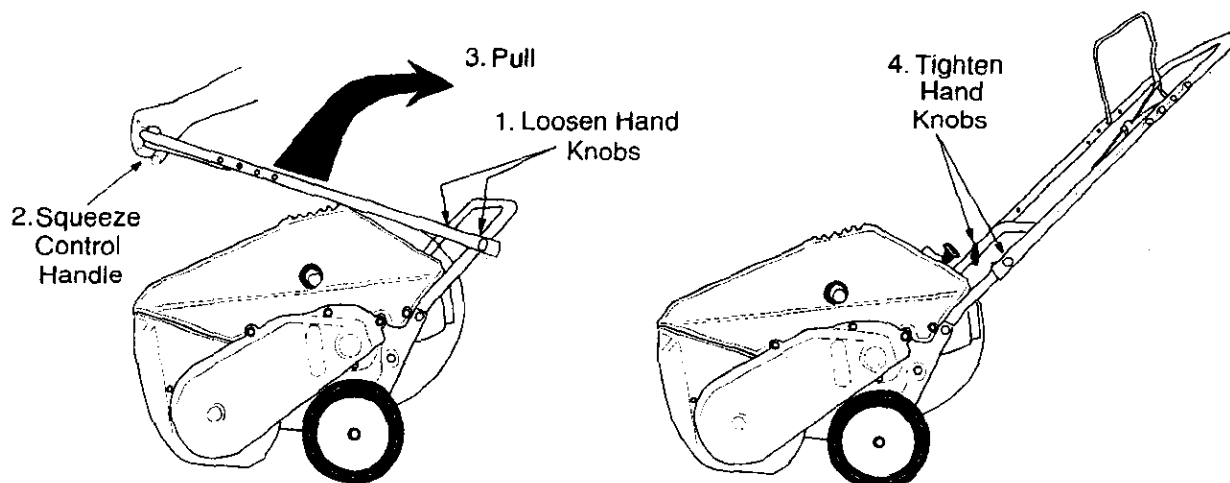

Figure 4

ATTACHING THE CONTROL CABLE

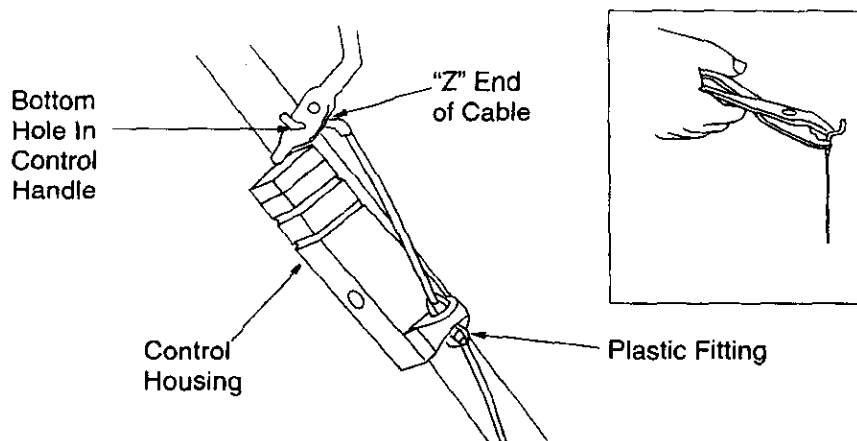

Figure 5

1. The control cable may already be attached to the control handle. Complete steps two and three if cable is loose.
2. Route the control cable over the lower handle. Place the end of the cable into the lower hole in the control housing as shown in Figure 5. Push the plastic fitting until it locks into the control housing.
3. Lift the control handle up, and hook the "Z" end of the control cable into the **bottom** hole in the control handle, from the outside to the inside (some models use only one hole). If necessary, use a pair of pliers to pull up on the end of the cable to obtain slack in order to hook it into the control handle. Hold the "Z" fitting with the pliers, not the cable, to avoid damaging the cable. (See inset - Figure 5.)

NOTE: The upper hole in the control handle provides for adjustment in belt tension. If you have only one hole in the control handle, refer to Belt Tension Adjustment Section of this manual.

INSTALLING THE CHUTE CRANK

(Models with Optional Extended Chute Crank only.)

On some units, the chute crank can be installed and secured from the top side of the snow thrower. Other units are equipped with an adaptor that requires the assembler to tip the unit forward on the auger housing in order to secure the crank from the underside.

To determine which installation procedure to follow, look at the chute crank coupler located on the top right side of the instrument panel above the model plate. See Figure 6. If the adaptor has a hole through it visible from the top, follow the "Secure from the Top" instructions. If the hole is not visible, follow the "Secure from the Underside" instructions.

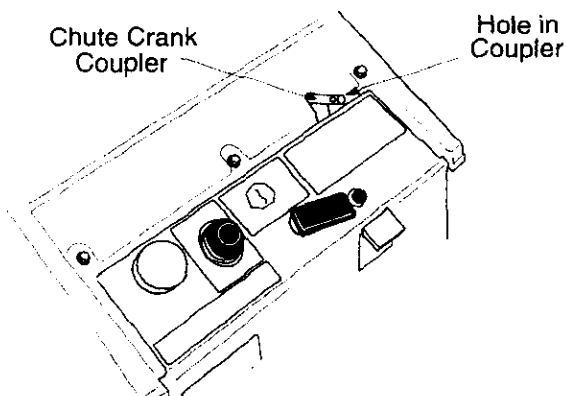

Figure 6

SECURE FROM THE TOP.

See Figure 7.

1. Thread one 5/16" hex nut all the way onto the eyebolt.
2. Slide the eyebolt onto the chute crank. Insert eyebolt into the hole in the lower handle.
3. Insert the chute crank into the coupler at the top right side of the snow thrower.
4. Rotate the crank to align holes, and insert the cotter pin. Bend ends of cotter in opposite directions to secure.
5. Secure eyebolt with 5/16" saddle washer and hex nut. The cupped side of washer goes against the handle. Adjust lower hex nut until the eyebolt is positioned so the chute crank turns freely. (does not bind)
6. Move upper hex nut down against the lower handle.
7. Tighten lower hex nut securely.

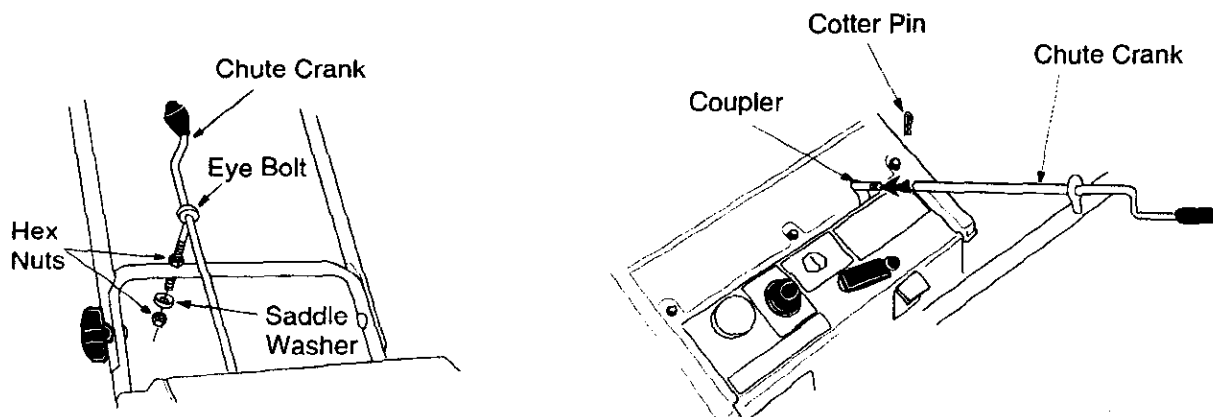

Figure 7

SECURE FROM THE UNDERSIDE.

See Figure 8.

1. Place a piece of the cardboard from the carton on a level surface. Tip the snow thrower forward so that the housing rests on the cardboard from the box.
2. Thread one 5/16" hex nut all the way onto the eyebolt.
3. Slide the eyebolt onto the chute crank. Insert eyebolt into the hole in the lower handle.
4. Insert the chute crank into the hole provided in the snow thrower cover. Place the end of the crank into the coupler located inside the snow thrower.
5. Rotate the crank to align holes, and insert the cotter pin (inside the snow thrower cover). Bend ends of cotter pin in opposite directions to secure.
6. Secure eyebolt with 5/16" saddle washer and hex nut. The cupped side of washer goes against the handle. Adjust lower hex nut until the eyebolt is positioned so the chute crank turns freely (does not bind).
7. Move upper hex nut down against the lower handle.
8. Tighten lower hex nut securely.

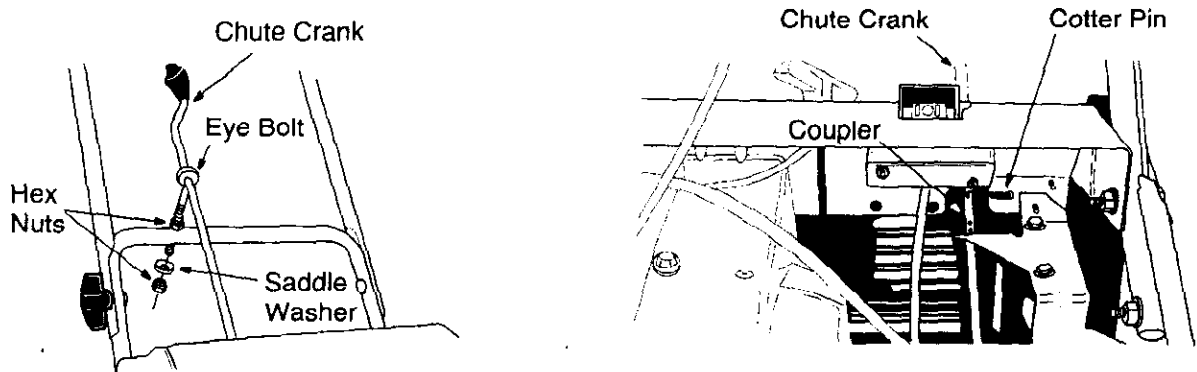

Figure 8

ASSEMBLING THE CHUTE

The snow thrower has been shipped with the upper chute pivoted all the way down. Assemble as follows:

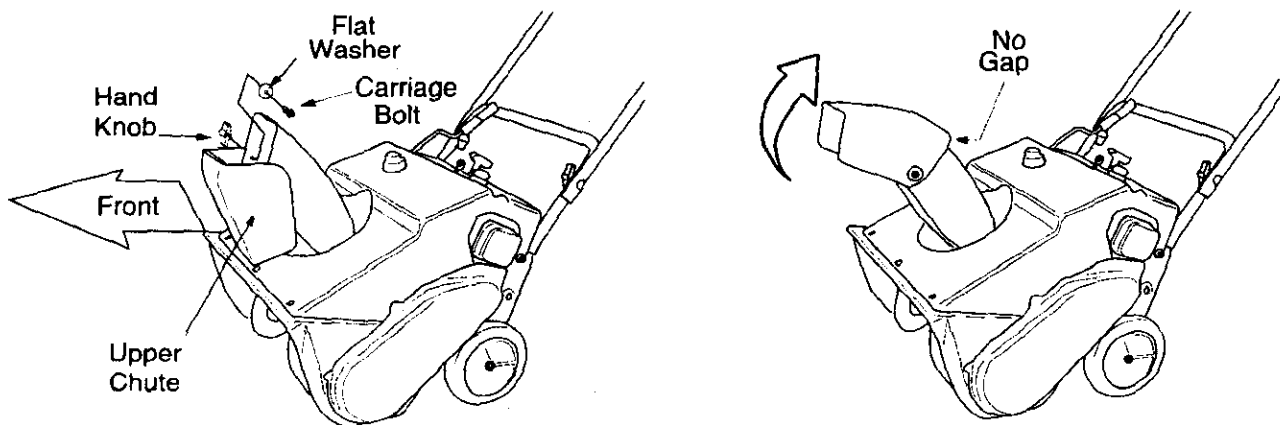

Figure 9

1. Turn the chute crank until the chute facing straight to the front. See Figure 9.
2. Remove the hand knob, flat washer and carriage bolt from the upper chute.
3. Pivot the upper chute up so there is no gap between the upper and lower chute. Secure with hardware just removed.

FUEL AND OIL MIXTURE



WARNING: Handle gasoline carefully. Remember that it is highly flammable. Never fill fuel tank indoors, when engine is running or while engine is still hot. Do not smoke when filling fuel tank.

Your snow thrower uses a two cycle engine that requires a mixture of gasoline and two cycle engine oil. Refer to the **Engine Operator's Manual** for proper Oil and Fuel Recommendations.

SECTION 6: CONTROLS

ENGINE OPERATING CONTROLS

The engine operating controls and their functions are as follows (see Figure 10):

Choke Lever - Place choke lever in "ON" position to start a cold engine.

Primer Button - Used to inject fuel directly into the carburetor to insure fast starts in cold weather.

Ignition Key - Ignition key must be in "ON" position to start engine.

Starter Handle - Used to manually start the engine.

Electric Starter (Optional Equipment) - Starts engine using a 120V power source

Plug for Electric Start (Optional Equipment) - Requires use of a two prong outdoor extension cord and a 120V power source

Spark Plug Cover - Spark Plug located under the cover.

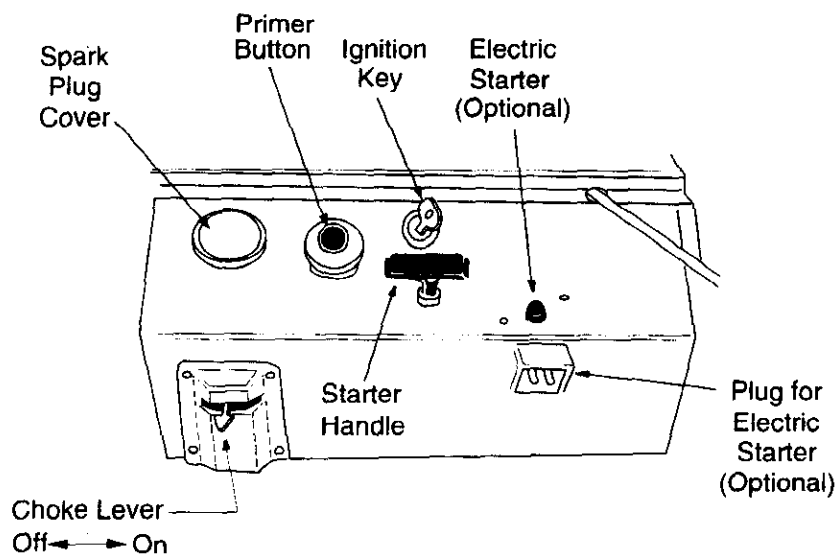

Figure 10

SNOW THROWER OPERATING CONTROLS

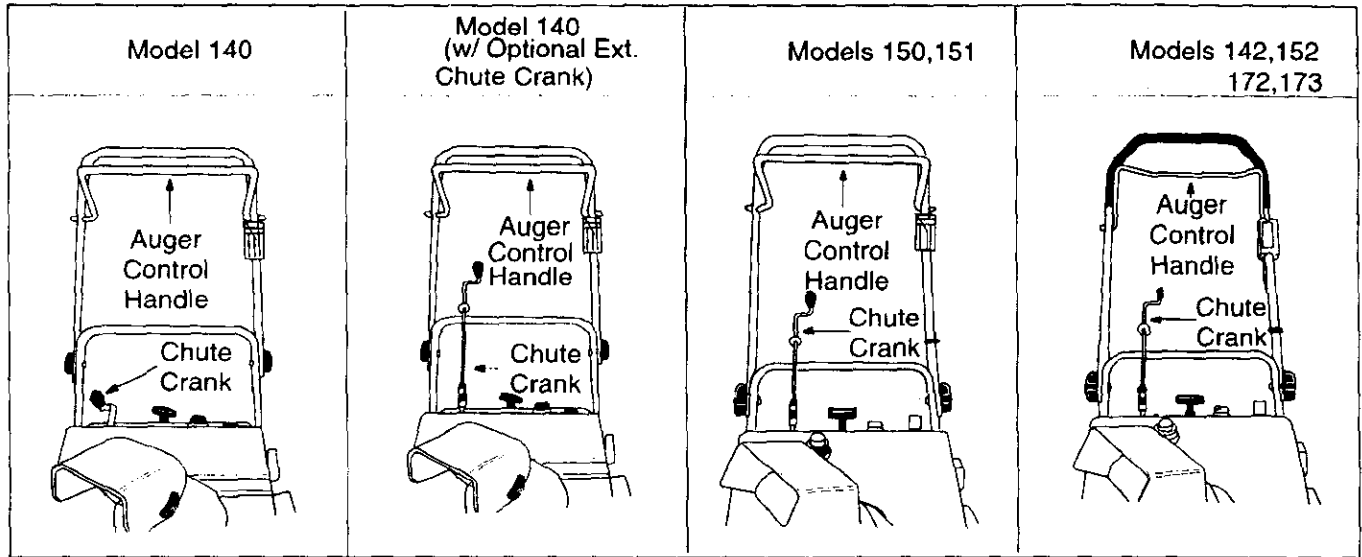

Figure 11

Auger Control Handle - Located on the upper handle, the auger control handle is used to engage and disengage the augers. See Figure 11. The snow thrower is designed to be propelled by the rotation of the augers. Pull the control handle back against the upper handle to engage the augers; release to disengage. See "Operating Tips" under "Operating the Snow Thrower" for more detail.

Chute Crank - Located on right side of dash panel. See Figure 11. The Chute Crank determines the direction snow will be discharged. Turn clockwise to discharge snow to the left. Turn counterclockwise to discharge to the right.

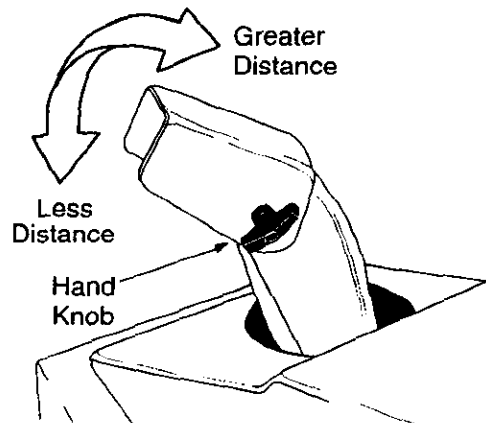

Figure 12

Discharge Chute - The angle of the discharge chute controls the distance the snow is thrown. The distance snow is thrown can be adjusted by tilting the discharge chute up for greater distance, or tilting down for less distance. Loosen the hand knob on the side of the discharge chute to adjust. Tilt the chute to desired position, and tighten hand knob. See Figure 12.

SECTION 7: OPERATION



Warning: Observe all warning labels on the snow thrower prior to use. See Section 1.

FUEL MIXTURE

Important: Mix oil with gasoline as instructed in the Oil and Fuel Recommendations Section in the separate Engine Operator's Manual packed with your snow thrower. Read and follow all instructions carefully.

BEFORE STARTING ENGINE

Read the Engine Operator's Manual carefully in its entirety before attempting to operate the machine. Be completely familiar with the controls and the proper use of the engine before operating the unit. Keep both Operator's Manuals in a safe place for future and regular use.

STARTING THE ENGINE

To start the engine on your snow thrower, follow the Starting Instructions in the Engine Operator's Manual.

OPERATING THE SNOW THROWER

1. Start the engine as instructed in the Engine Operator's Manual.
2. Adjust the discharge chute up or down as desired. Then use the chute crank to position the discharge to discharge snow with the wind. Do not throw snow toward a building as hidden objects could be discharged with enough force to cause damage.
3. Making certain no bystanders or obstacles are in front of the unit, engage the auger control handle. As the snow thrower starts to move, maintain a firm hold on the handle, and guide the snow thrower along the path to be cleared.
4. Release the auger control handle to stop the snow throwing action and forward motion.

TO STOP THE ENGINE

1. Run the engine for a few minutes before stopping to help dry any moisture on the engine.
2. To stop engine: Turn ignition key to OFF position and remove it from the snow thrower.

NOTE: Do not lose ignition key. Keep it in a safe place. Engine will not start without the ignition key.

3. Wipe all snow and moisture from the unit. Move the choke lever back and forth several times and leave in the ON position.

OPERATING TIPS

1. For most efficient snow removal, remove snow immediately after it falls.
2. Discharge snow downwind whenever possible. Slightly overlap each previous cleared path.
3. Lifting up on the handle will allow the rubber on the augers to propel the snow thrower forward. Pushing downward on the handle will raise the augers off the ground and stop the forward motion.

NOTE: Excessive upward pressure on the handle will result in premature wear on the rubber auger blades which would not be covered by warranty.

4. Run the engine for a few minutes before stopping to help dry any moisture on the engine.
5. Clean the snow thrower thoroughly after each use.
6. It is not recommended that you operate this snow thrower on gravel as loose gravel can be easily picked up and thrown by the auger, causing an injury or damage to the snow thrower.

SECTION 8: ADJUSTMENTS



WARNING: NEVER attempt to clean chute or make any adjustments or repairs while engine is running.

SHAVE PLATE ADJUSTMENT

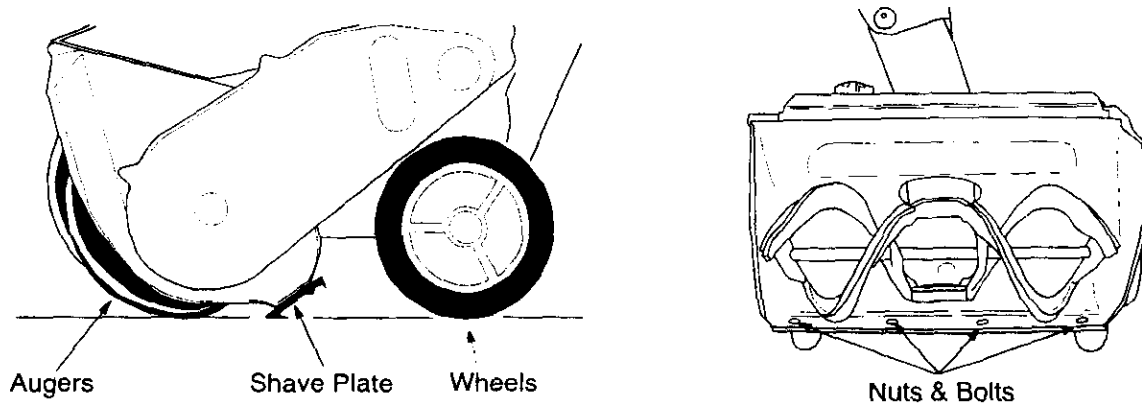

Figure 13

1. To check the adjustment of the shave plate, place the unit on a level surface. See Figure 13. The wheels, shave plate and augers should all contact the level surface. If the shave plate is adjusted too high, the snow may blow under the housing. If the shave plate wears excessively, or the unit will not self propel the shave plate may be adjusted too low.

NOTE: On new units or units with a new shave plate installed, the augers may slightly raise off the ground.

2. To adjust, tip the snow thrower back so it rests on the handle. See Figure 13. Loosen the lock nuts and bolts which secure the shave plate to the housing. Move the shave plate to desired position and retighten the nuts and bolts. Make certain all nuts and bolts are tightened securely.

BELT TENSION ADJUSTMENT

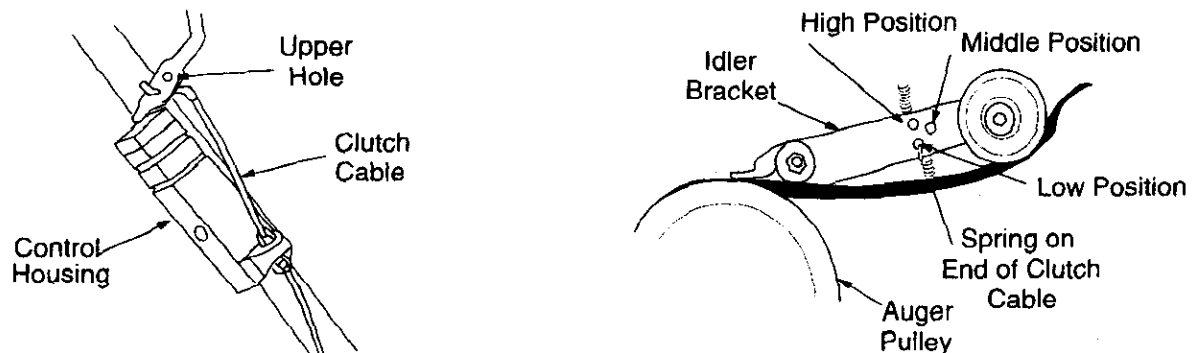

Figure 14

Periodic adjustment of the belt tension may be required due to normal stretch and wear on the belt. Adjustment is needed if the augers seem to hesitate while turning, but the engine maintains the same speed.

The upper hole in the control handle provides adjustment for belt tension. To adjust, disconnect the "Z" end of control cable from the bottom hole in the control handle. Refer to Figure 14. Hook the cable into the upper hole in control handle.

If additional adjustment is required, adjust the other end of the control cable at the Idler Bracket as follows: Remove the belt cover. See Figure 15. There are three adjustment holes provided in the Idler Bracket Assembly. See Figure 14. To adjust, move the extension spring on the end of the clutch cable to the next higher adjustment position on the Idler Bracket Assembly. Reassemble belt cover.

SECTION 9: MAINTENANCE



WARNING: NEVER attempt to clean chute or make any adjustments or repairs while engine is running.

NOTE: Check engine and snow thrower frequently for loose nuts, bolts, etc., and keep these items tightened.

ENGINE

Refer to the separate Engine Operator's Manual packed with your snow thrower for all engine maintenance procedures.

SHAVE PLATE REPLACEMENT

The shave plate is subject to wear. It should be checked periodically. There are two wearing edges and the shave plate can be reversed. Refer to Figure 13.

To remove the shave plate:

1. Remove the four carriage bolts and hex lock nuts which attach it to the snow thrower housing.
2. Install new shave plate, making sure the heads of the carriage bolts are on the inside of the housing.
3. Adjust the shave plate according to procedure in the "Adjustment" section of this manual.
4. Tighten securely.

BELT REPLACEMENT

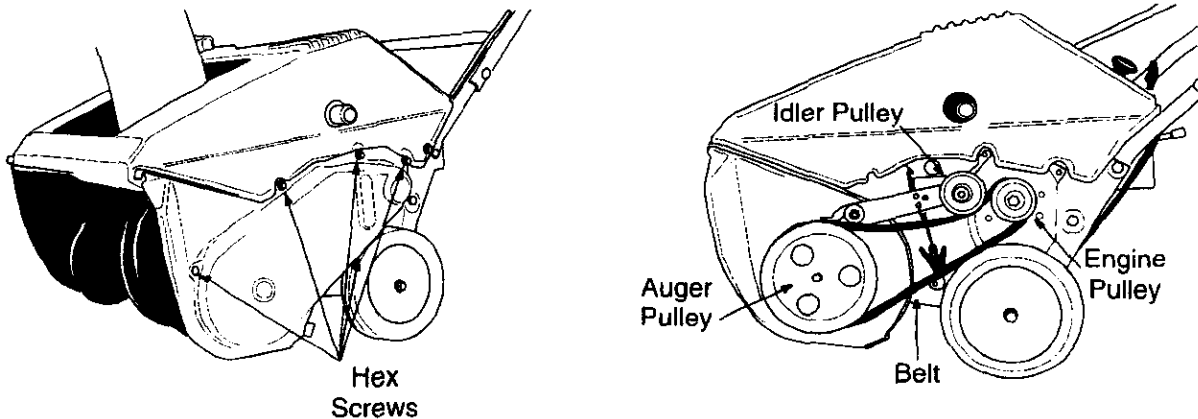

Figure 15

1. Remove the belt cover by removing five hex screws. See Figure 15.
2. Pull up on the idler pulley and slip the belt off engine pulley.
3. Push down on idler pulley and slip the belt off auger pulley.
4. Reassemble new belt in reverse order.
5. Reinstall the belt cover.

SECTION 10: OFF-SEASON STORAGE



WARNING: Never store engine with fuel in tank indoors or in enclosed, poorly ventilated areas where fuel fumes may reach an open flame, spark or pilot light as on a furnace, water heater, clothes dryer, or other gas appliance.

- Clean snow thrower thoroughly.
- Follow "Storage" instructions found in the separate Engine Operator's Manual. Preparing the engine for storage properly is important to prevent problems next season.
- Store in a clean, dry area. Block the snow thrower up so it is not resting on the rubber auger blades.

NOTE: When storing any type of power equipment in an poorly ventilated or metal storage shed, care should be taken to rustproof the equipment, especially springs, cables and all moving parts.

SECTION 11: TROUBLE SHOOTING GUIDE

Trouble	Possible Cause(s)	Corrective Action
Engine fails to start	Fuel tank empty, or stale fuel. Blocked fuel line. Key not in switch on engine. Spark plug wire disconnected. Faulty spark plug. Improper gasoline and oil mixture.	Fill tank with clean, fresh gasoline/oil mixture. Refer to engine manual packed with your unit. Clean fuel line. Insert Key Connect wire to spark plug. Clean, adjust gap or replace. Refer to fuel mixture in separate engine manual.
Engine runs erratic	Unit running on CHOKE. Blocked fuel line or stale fuel. Water or dirt in fuel system. Carburetor out of adjustment.	Move choke lever to OFF position. Clean fuel line; fill tank with clean, fresh gasoline/oil. Drain fuel tank. Refill with clean, fresh gasoline/oil. Refer to engine manual packed with your unit Refer to engine manual packed with your unit or have carburetor adjusted by an authorized service dealer
Engine overheats	Incorrect fuel mixture. Carburetor not adjusted properly.	Drain fuel tank. Refill with proper fuel mixture. Refer to engine manual packed with your unit. Refer to engine manual packed with your unit or have carburetor adjusted by an authorized service dealer.
Loss of power	Spark plug wire loose. Vent in gas cap plugged. Exhaust port plugged.	Connect and tighten spark plug wire. Clear vent. Clean-see maintenance section.
Excessive vibration	Loose parts or damaged auger.	Stop engine immediately and disconnect spark plug wire. Tighten all bolts and nuts. Make all necessary repairs. If vibration continues, have unit serviced by an authorized service dealer.
Unit fails to propel itself.	Incorrect adjustment of drive cable Drive belt loose or damaged.	Adjust drive cable. Refer to Adjustment section of this manual. Replace drive belt. Refer To Belt Replacement in Maintenance section of this manual.
Unit fails to discharge snow.	Discharge chute clogged. Foreign object lodged in auger. Incorrect adjustment of drive cable. Drive belt loose or damage.	Stop engine immediately and disconnect spark plug wire. Clean discharge chute and inside of auger housing Stop engine immediately and disconnect spark plug wire. Remove object from auger. Adjust drive cable. Refer to Belt Tension Adjustment in Adjustment section of this manual. Replace drive belt. Refer to Belt Replacement in Maintenance section of this manual.

Refer to separate engine manual packed with your mower for more engine related information.

NOTE: For repairs beyond the minor adjustments listed above, contact your nearest authorized service dealer or call 1-800-800-7310 for the Customer Support Center.

Models

140

150

E150

E151

REF. NO.	PART NO.	DESCRIPTION	QTY.
1	710-1270	Screw—Oval C-Sink L	1
2	710-0487	Bolt Carriage	2
3	712-0324	Nut Insl. Lock	1
4	720-0276	Knob—Handle	2
5	725-0157	Tie Cable	1
6	746-0883	Body—Lever Control	1
7	747-0946	Handle Ass'y. Control	1
8	749-0705	Handle—Upper	1
9	736-0451	Washer Saddle	2

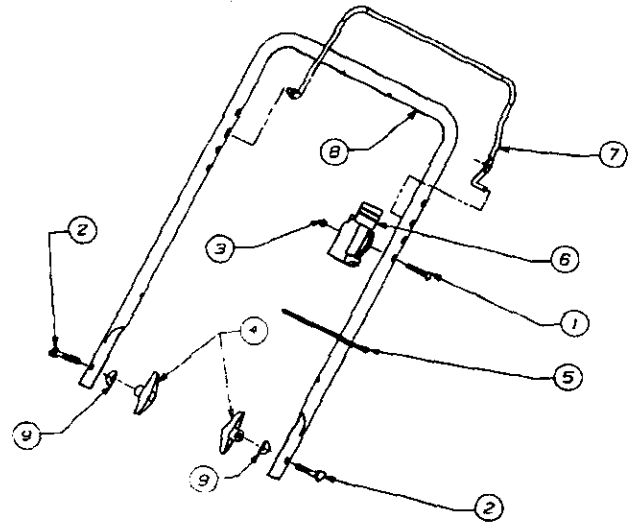

Models

142

E152

E172

E173

REF. NO.	PART NO.	DESCRIPTION	QTY.
1	710-1270	Screw—Oval C-Sink L	1
2	710-0487	Bolt—Carriage	2
3	712-0324	Nut Insul. Lock	1
4	720-0295	Grip Foam	1
5	720-0284	Knob Handle	2
6	725-0157	Tie Cable	1
7	736-0451	Washer Saddle	2
8	746-0883	Body—Lever Control	1
9	747-0956	Handle Ass'y. Control	1
10	749-0711A	Handle—Upper	1

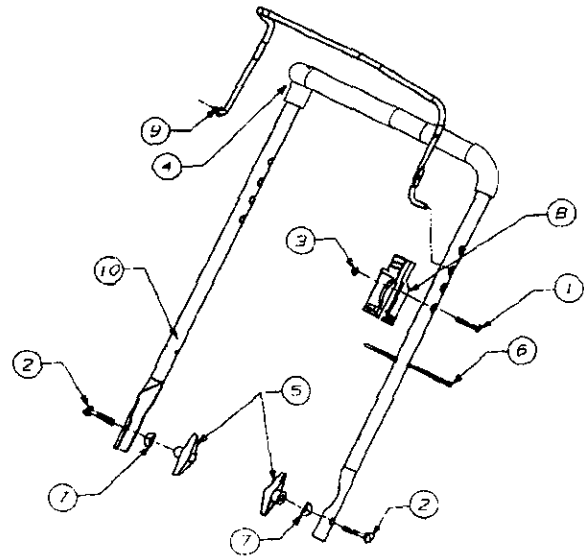

Models 140 thru E173

REF. NO.	PART NO.	DESCRIPTION	QTY.	REF. NO.	PART NO.	DESCRIPTION	QTY.
1	710-0167	Bolt—Carriage	4	25	736-0176	Washer—Flat	1
2	710-0276	Bolt—Carriage	1	26	736-0159	Washer	2
3	710-0323	Screw—Pan Head	1	27	736-0326	Washer—Flat	1
4	710-0451	Bolt—Carriage	1	28	736-0329	Washer—Lock	1
5	710-0642	Screw—Hex Washer	1	30	741-0600	Ball Bearing	2
6	710-1005	Screw—Hex Washer	6	31	746-0910A	Cable—Clutch	1
7	710-0773	Screw—Hex Washer	2	32	748-0234	Spacer—Shoulder	1
8	710-0896	Screw—Hex Washer	4	33	749-0796	Handle—Lower	1
9	710-3015	Screw—Hex Cap	6	34	756-0313	Idler—Flat	1
10	711-0848A	Axle	1	35	784-5174	Cup—Bearing	2
11	712-0429	Nut—Hex Center Lock	1	36	784-5176	Cover—Belt	1
12	712-3010	Nut—Hex	3	37	784-5175B	Bracket—Idler/Brake	1
13	712-0116	Nut—Hex Lock	1	38	684-0114	Housing—Blower	1
15	712-3027	Nut—Hex Lock Flanged	10	39	784-5485	Auger Ass'y. Comp.	1
16	720-0284	Knob	1	40	753-0613	Auger Rubber Replacement	1
17	731-0851A	Keeper—Chute	3	41	710-0352	Screw—Hex Washer	1
18	731-0915B	Chute—Lower	1	42	784-5720	Bracket - Crank	1
19	731-0921	Chute—Upper	1	43	710-0451	Screw - Cap	2
20	731-1033	Shave Plate	1	44	736-0242	Washer - Bell	2
21	732-0357A	Spring—Extension	1	45	741-0475	Bushing	1
22	736-0108	Washer—Flat	2	46	710-0459A	Screw - Cap	1
23	736-0119	Washer—Lock	1				

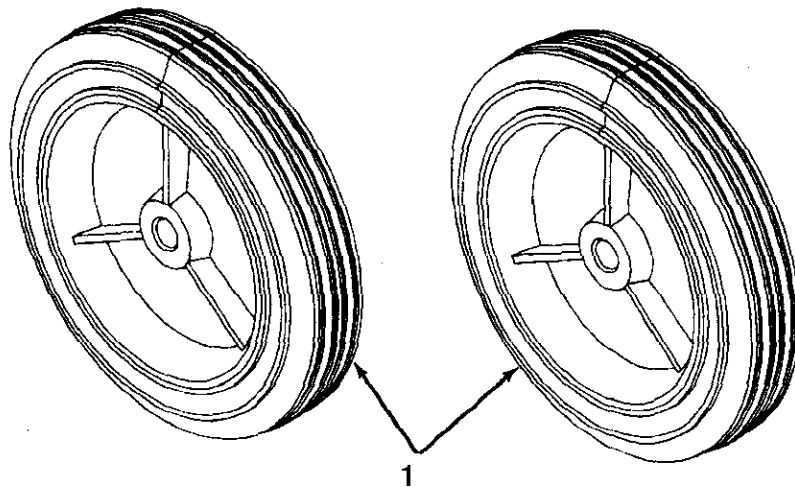

REF. NO.	PART NO.	DESCRIPTION	QTY.
1	734-1176	Wheel Ass'y.	2

Models 140 and E142

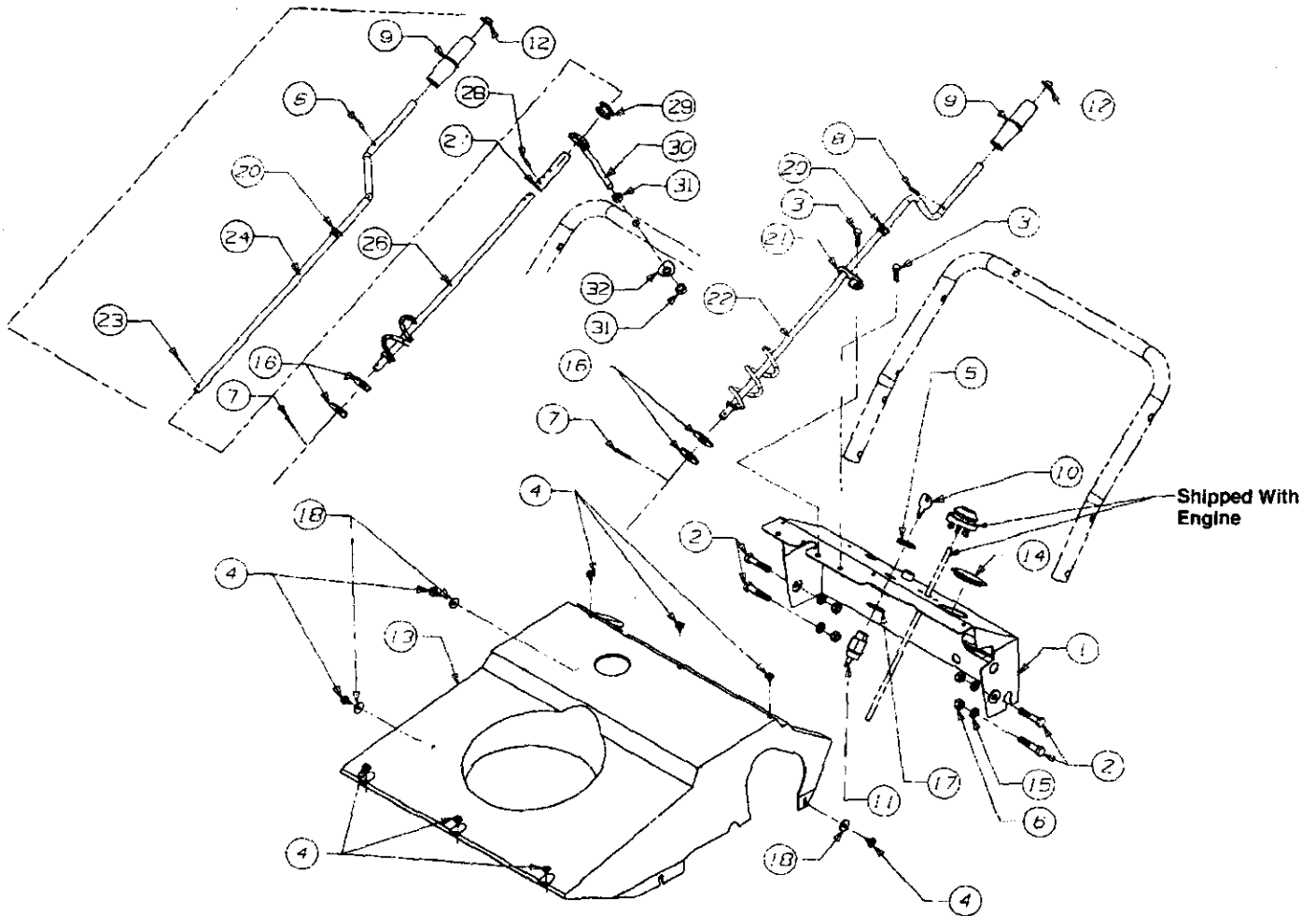

REF. NO.	PART NO	DESCRIPTION	QTY.	REF. NO.	PART NO	DESCRIPTION	QTY.
1	684-0056	Dash—21*	1	16	736-0185	Washer - Flat	2
2	710-0805	Screw—Hex	4	17	736-0225	Washer Internal Lock	1
3	710-0895	Screw—Hex Tap	2	18	736-0400	Washer Flat	3
4	710-1268	Screw—Hex Tap	9	20	741-0475	Bushing	1
5	712-0252	Nut Hex	1	21	784-5178A	Bracket Chute Crank	1
6	712-3010	Nut—Hex	4	22	784-5344	Crank Ass'y. Chute	1
7	714-0104	Pin—Cotter	1	23	714-0111	Cotter Pin †	1
8	715-0138	Pin Roll	1	24	747-0737	Crank - Chute - Upper †	1
9	720-0201A	Knob—Chute Crank	1	26	684-0126	Crank - Chute - Lower †	1
10	725-0201	Key—Ignition	2	27	750-0785	Spacer †	1
11	725-1425	Switch—Key	1	28	715-0138	Pin - Roll †	1
12	726-0100	Nut Push	1	29	735-0234	Grommet - Rubber †	1
13	731-0702	Shroud	1	30	747-0697	Eyebolt - Chute Crank †	1
14	731-1133A	Plug	1	31	712-3010	Nut - Hex †	2
15	736-0119	Washer Lock	4	32	736-0451	Washer - Saddle †	1

† Optional Model 140 Chute Crank Assembly

Models 150, E150, E173

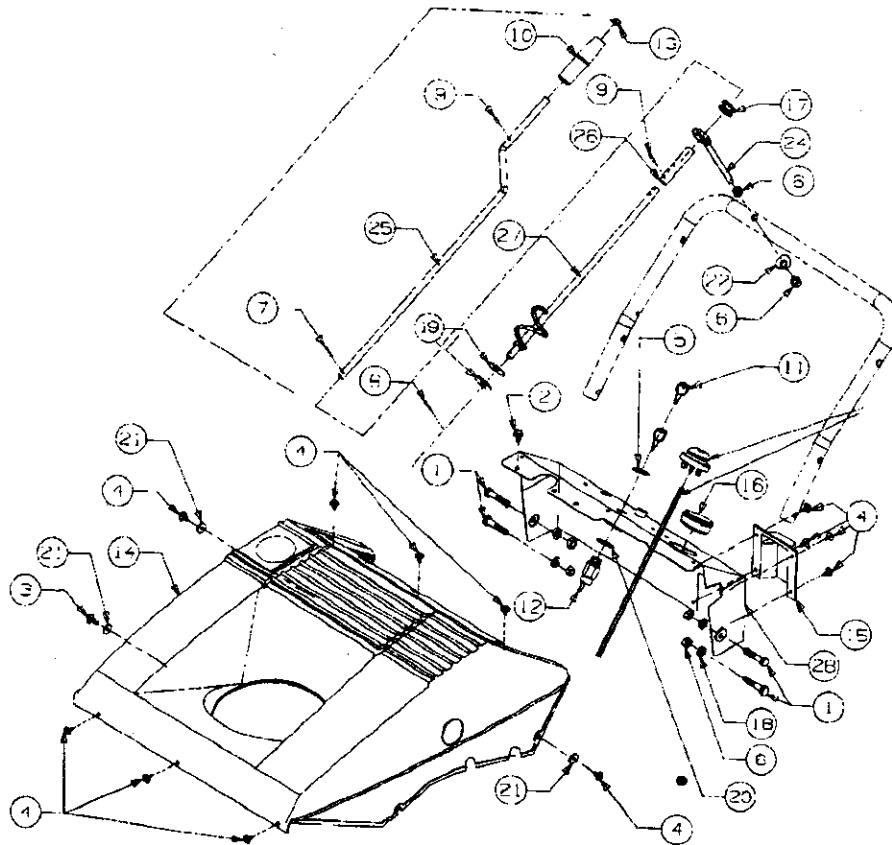

REF. NO.	PART NO	DESCRIPTION	QTY.	REF. NO.	PART NO	DESCRIPTION	QTY.
1	710-0805	Screw-Hex	4	15	731-1089A	Cover-Choke	1
2	710-1005	Screw-Hex Washer	1	16	731-1133A	Plug-Insert	1
3	710-1003	Screw-Hex	1	17	735-0234	Grommet-Rubber	1
4	710-1268	Screw-Hex	12	18	736-0119	Washer-Lock	4
5	712-0252	Nut-Jam	1	19	736-0185	Washer-Flat	2
6	712-3010	Nut-Hex	6	20	736-0225	Washer-Lock-Internal	1
7	714-0104	Hairpin	1	21	736-0400	Washer-Flat	3
8	714-0507	Pin-Cotter	1	22	736-0451	Washer-Saddle	1
9	715-0138	Pin Roll	2	24	747-0697	Eyebolt-Chute Crank	1
10	720-0201A	Knob	1	25	747-0737	Crank-Chute-Lower	1
11	725-0201	Key-Ignition	2	26	750-0785	Spacer	1
12	725-1425	Switch	1	27	684-0126	Crank-Chute-Upper	1
13	726-0100	Cap-Push	1	28	784-5572	Dash	1
14	731-1087	Shroud-Black	1				

Models E151, E172,

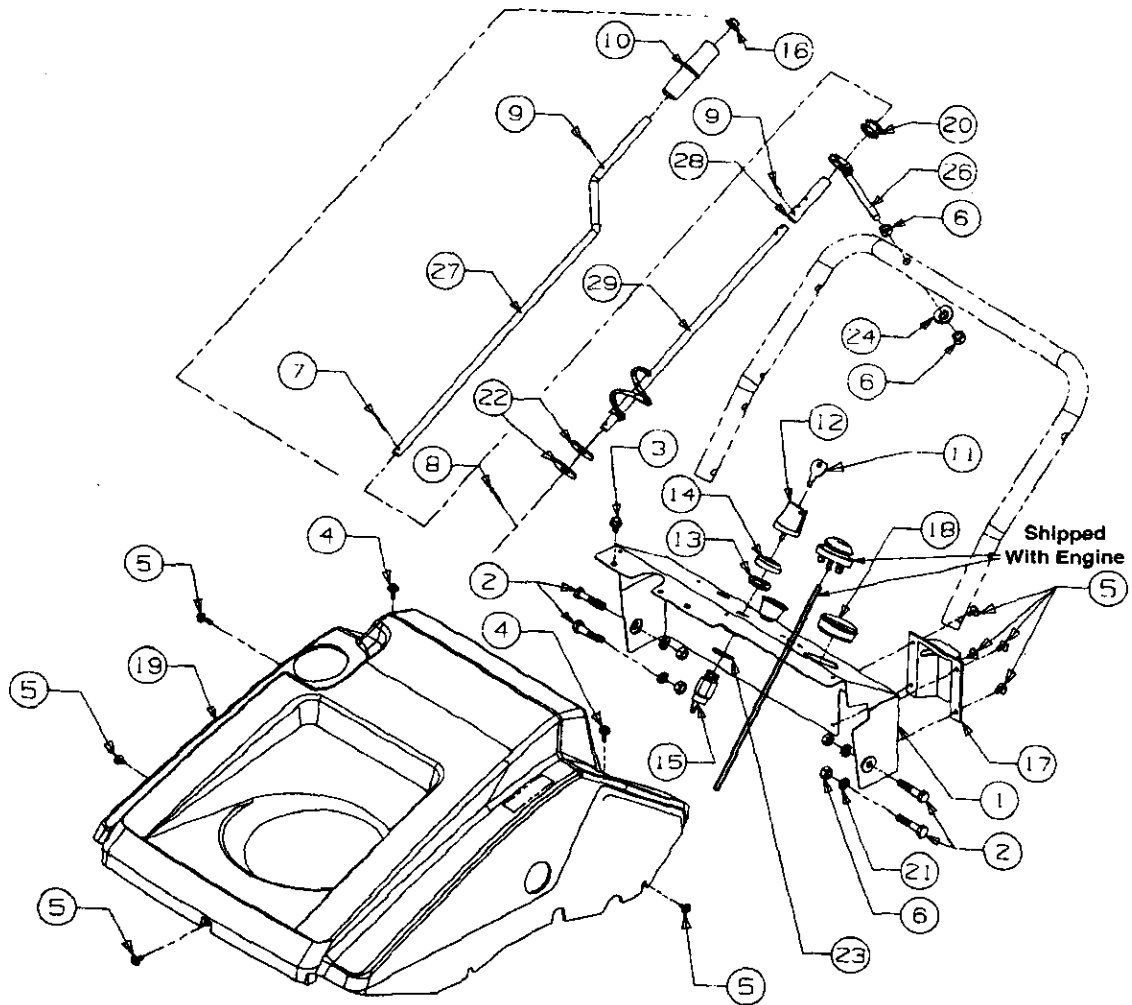

REF. NO.	PART NO	DESCRIPTION	QTY.	REF. NO.	PART NO	DESCRIPTION	QTY.
1	784-5572	Dash	1	15	725-1425	Switch—Key	1
2	710-0805	Screw—Hex Cap	4	16	726-0100	Cap—Push	1
3	710-1005	Screw—Hex Washer	1	17	731-1089A	Cover—Choke	1
4	710-1003	Screw—Hex	2	18	731-1133A	Plug—Insert	1
5	710-1268	Screw—Hex	8	19	731-1765	Shroud—Black	1
6	712-3010	Nut—Hex	6	20	735-0234	Grommet—Rubber	1
7	714-0104	Hairpin	1	21	736-0119	Washer—Lock	4
8	714-0507	Pin—Cotter	1	23	736-0225	Washer—Lock Internal	1
9	715-0138	Pin—Roll	2	24	736-0451	Washer—Saddle	1
10	720-0201A	Knob	1	26	747-0697	Eyebolt—Chute Crank	1
11	725-0201	Key—Ignition	1	27	747-0737	Crank—Chute Upper	1
12	725-1341B	Key—Ignition with Logo	1	28	750-0785	Spacer	1
13	725-1346	Nut—Ignition Switch	1	29	684-0126	Crank—Chute Lower	1
14	725-1347	Cover—Ignition Switch	1				

Models 140, E142

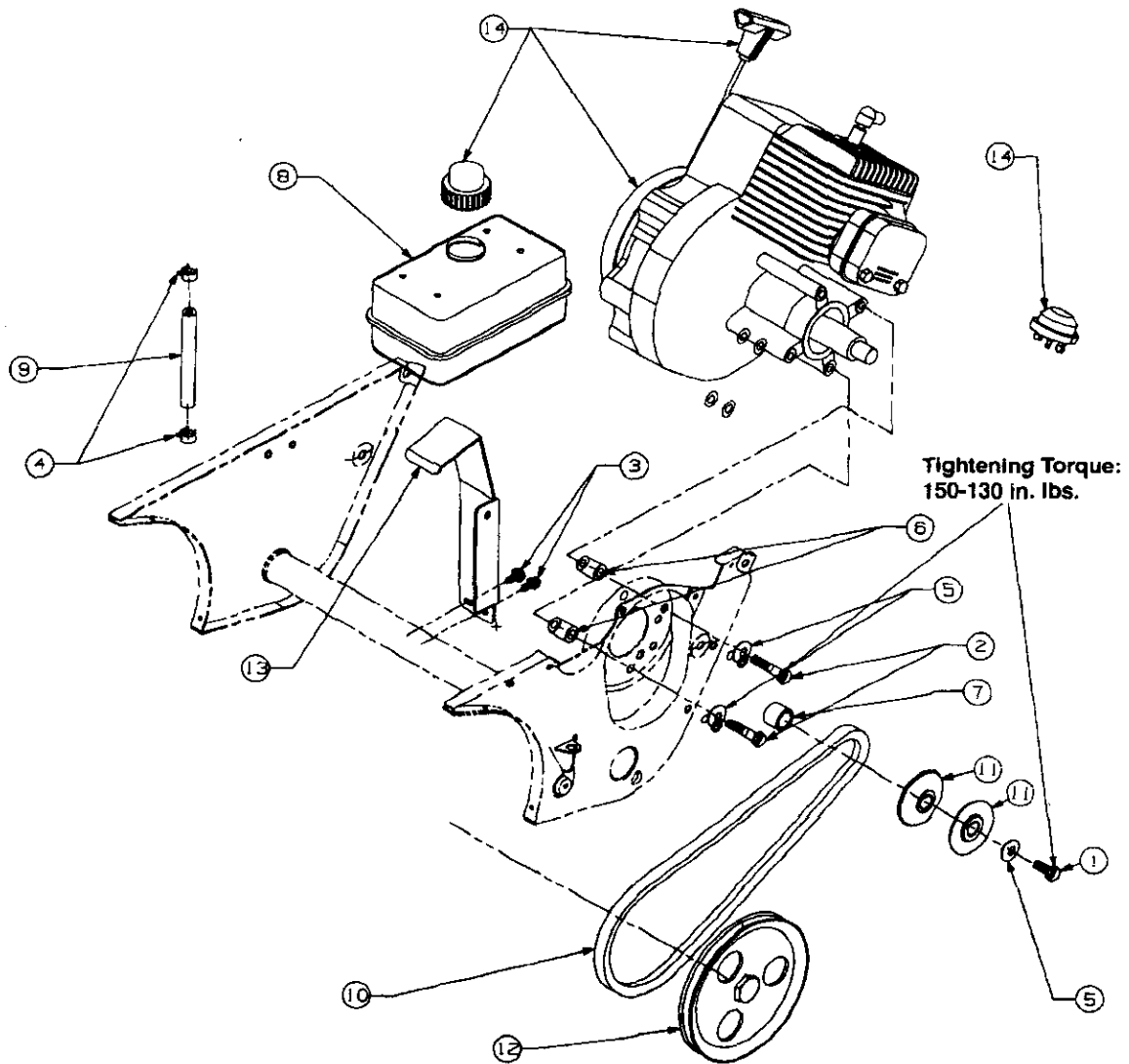

REF. NO.	PART NO	DESCRIPTION	QTY.	REF. NO.	PART NO	DESCRIPTION	QTY.
1	710-0157	Screw—Hex Cap	1	9	751-0535-12	Hose—Fuel 12"	1
2	710-0805	Screw—Hex Cap	4	10	754-0367	V-Belt	1
3	710-0896	Screw—Washer	2	11	756-0416B	V-Pulley Half	2
4	726-0205	Clamp—Hose	2	12	756-0550	Pulley	1
5	736-0242	Washer—Bell	5	13	784-5177	Engine Support Bracket	1
6	750-0589	Spacer	4	14	—	Obtain from Engine Manufacturer	1
7	750-0716	Spacer	1		OEM-390-697	Electric Start Kit (Optional)	1
8	751-0352	Tank—Fuel	1	N/I			

Model 150

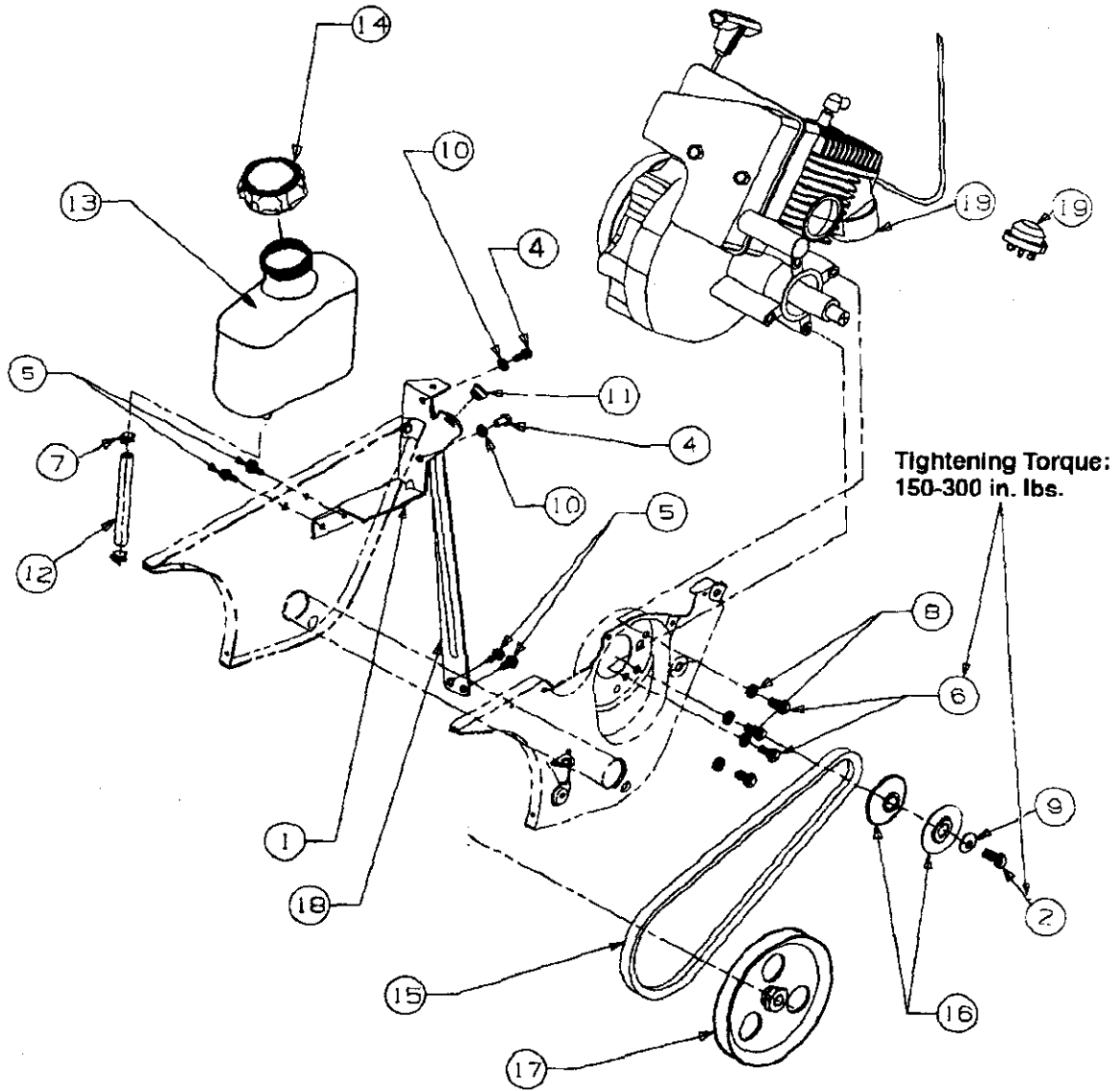

REF. NO.	PART NO.	DESCRIPTION	QTY.	REF. NO.	PART NO.	DESCRIPTION	QTY.
1	705-5139	Bracket - Support Gas Tank	1	11	741-0475	Bushing - Plastic	1
2	710-0157	Screw - Hex Cap	1	12	751-0535-16	Hose - Fuel Line 16"	1
4	710-0289	Screw - Hex	2	13	751-0540A	Tank - Fuel 2 Qt.	1
5	710-0896	Screw - Washer	2	14	751-0800	Cap - Fuel	1
6	710-3025	Screw - Hex Cap	4	15	754-0101A	V-Belt	1
7	726-0205	Clamp - Hose	2	16	756-0416B	V-Pulley Half	2
8	736-0119	Washer - Lock	4	17	756-0475	Pulley	1
9	736-0242	Washer - Bell	1	19	—	Obtain from Engine Manufacturer	1
10	736-0329	Washer - Lock	2	N/I	OEM-390-996	Electric Start Kit (Optional)	1

Models E150, E151, E152, E172, E173

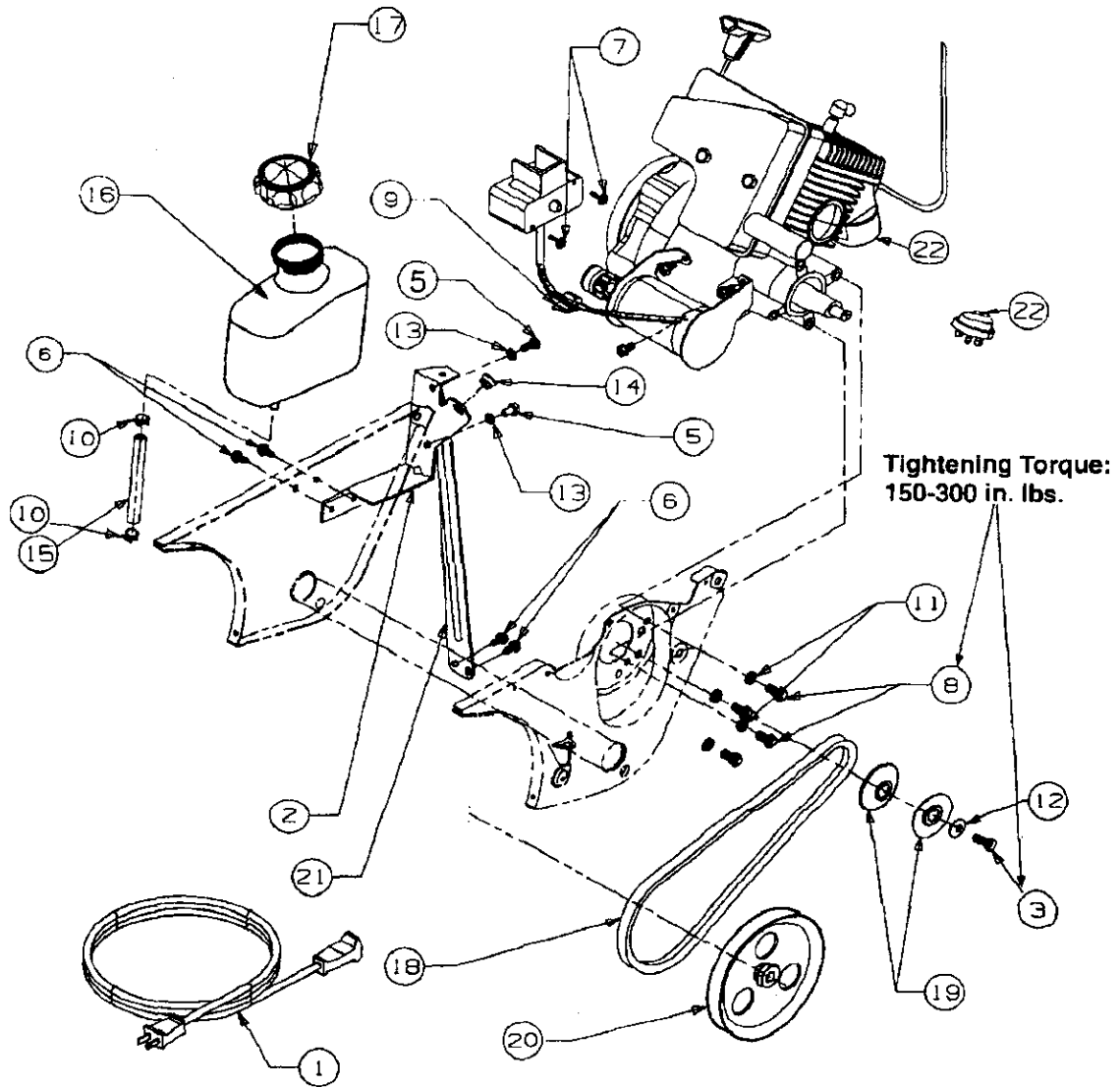

REF. NO.	PART NO	DESCRIPTION	QTY.	REF. NO.	PART NO	DESCRIPTION	QTY.
1	629-0236	Cord - Extension 110V3M 2 Prong		12	736-0242	Washer - Bell	1
2	705-5139	Bracket - Support Fuel Tank	1	13	736-0329	Washer - Lock	2
3	710-0157	Screw - Hex Cap	1	14	741-0475	Bushing - Plastic	1
5	710-0289	Screw - Hex	2	15	751-0535-16	Hose - Fuel Line 16"	1
6	710-0896	Screw - Washer	2	16	751-0540A	Tank - Fuel 2 Qt.	1
7	710-1003	Screw - Hex	2	17	751-0800	Cap - Fuel - Black Letters	1
8	710-3025	Screw - Hex Cap	4	18	754-0101A	V-Belt	1
9	726-0152	Clamp - Mounting	1	19	756-0416B	V-Pulley Half	2
10	726-0205	Clamp - Hose	2	20	756-0475	Pulley	1
11	736-0119	Washer - Lock	4	22	—	Obtain from Engine Manufacturer	1

MANUFACTURER'S LIMITED WARRANTY FOR:



For TWO YEARS from the date of retail purchase within the United States of America, its possessions and territories, MTD PRODUCTS INC will, at its option, repair or replace, for the original purchaser, free of charge, any part or parts found to be defective in material or workmanship. This warranty covers units which have been operated and maintained in accordance with the operating instructions furnished with the unit, and which have not been subject to misuse, abuse, commercial use, neglect, accident, improper maintenance or alteration.

Normal wear parts or components thereof are subject to separate terms as noted below in the "No Fault Ninety Day Consumer Warranty" clause.

All normal wear part failures will be covered on this product for a period of 90 days regardless of cause. After 90 days, but within the two year period, normal wear parts failures will be covered ONLY IF caused by defects in material or workmanship of OTHER component parts. Normal wear parts are defined as batteries*, belts, blades, blade adapters, grass bags, rider deck wheels, seats, snow thrower skid shoes, shave plates and tires.

How to obtain service: Warranty service is available, with proof of purchase, through your local authorized service dealer. To locate the dealer in your area, please check the yellow pages or contact the Customer Service Department of MTD PRODUCTS INC, P. O. Box 368022, Cleveland, Ohio 44136-9722. Phone 1 (800) 800-7310. The return of a complete unit will not be accepted by the factory unless prior written permission has been extended by the Customer Service Department of MTD PRODUCTS INC.

Transportation charges: Transportation charges for the movement of any power equipment unit or attachment are the responsibility of the purchaser.

Units exported out of the United States: MTD PRODUCTS INC does not extend any warranty for

products sold or exported outside of the United States of America, its possessions and territories, except those sold through MTD PRODUCTS INC's authorized channels of export distribution.

Other Warranties:

1. The engine or component parts thereof carry separate warranties from their manufacturers. Please refer to the applicable manufacturer's warranty on these items.
2. *Batteries are covered by a 90-day replacement warranty.
3. Log splitter pumps, valves and cylinders or component parts thereof are covered by a one year warranty.
4. All other warranties, express or implied, including any implied warranty of merchantability or fitness for a particular purpose, are hereby expressly disclaimed in their entirety.
5. The provisions as set forth in this warranty provide the sole and exclusive remedy of MTD PRODUCTS INC's obligations arising from the sales of its products. MTD PRODUCTS INC will not be liable for incidental or consequential loss or damage.

How state law relates to this warranty: This limited warranty gives you specific legal rights, and you may also have other rights which vary from state to state. Certain disclaimers are not allowed in some states and therefore they may not apply to you under all circumstances.

NOTE: This warranty does not cover routine maintenance items such as lubricants, filters, blade sharpening and tune-ups, or adjustments such as brake adjustments, clutch adjustments or deck adjustments. Nor does this warranty cover normal deterioration of the exterior finish due to use or exposure.