

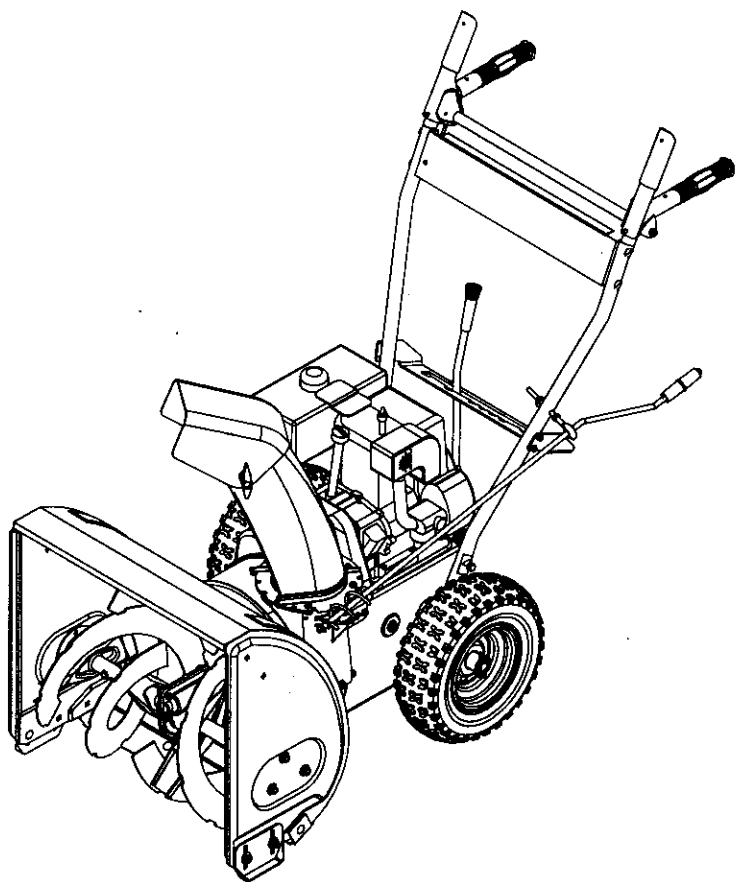

# OPERATOR'S MANUAL



## SNOW THROWER Model 611



### IMPORTANT: READ SAFETY RULES AND INSTRUCTIONS CAREFULLY

**Warning:** This unit is equipped with an internal combustion engine and should not be used on or near any unimproved forest-covered, brush-covered or grass-covered land unless the engine's exhaust system is equipped with a spark arrester meeting applicable local or state laws (if any). If a spark arrester is used, it should be maintained in effective working order by the operator. In the State of California the above is required by law (Section 4442 of the California Public Resources Code). Other states may have similar laws. Federal laws apply on federal lands. A spark arrester for the muffler is available through your nearest engine authorized service dealer or contact the service department, P.O. Box 368022 Cleveland, Ohio 44136-9722.

**MTD PRODUCTS INC. P.O. BOX 368022 CLEVELAND, OHIO 44136-9722**

---

## SECTION 1: FINDING YOUR MODEL NUMBER

This Operators Manual is an important part of your new snow thrower. It will help you assemble, prepare and maintain your snow thrower. Please read and understand what it says.

Before you start to prepare your snow thrower for its first use, please locate the model plate and copy the information from it in this Operators Manual. The information on the model plate is very important if you need help from your dealer or the MTD customer support department.

- Every snow thrower has a model plate. You can locate it by standing behind the unit in the operating position and looking down at the frame below engine. See Figure 1

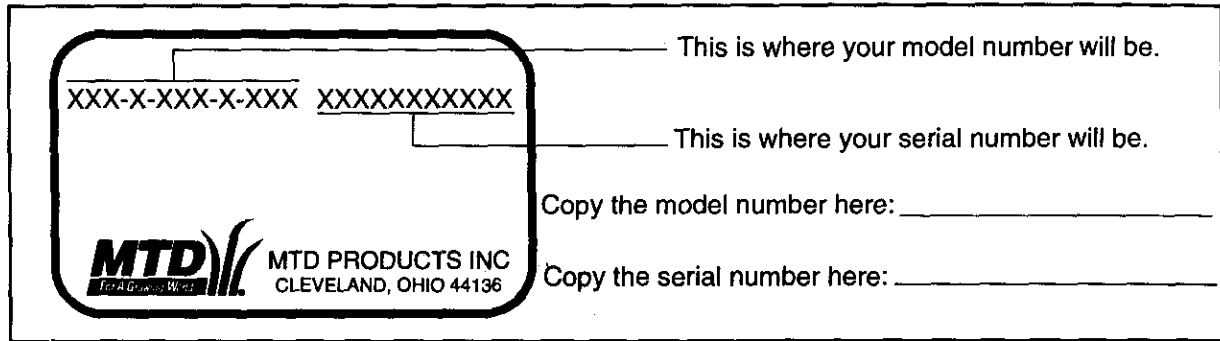

Figure 1

---

## SECTION 2: CALLING CUSTOMER SUPPORT

- **LOCATE YOUR MODEL NUMBER AND SERIAL NUMBER** — Record this information in the space provided. To find your unit's specific model number and serial number, see SECTION 1: FINDING YOUR MODEL NUMBER.
- If you are having difficulty assembling this product or if you have any questions regarding the controls, operation or maintenance of this unit, please call the Customer Support Department.
- Customer Support can be reached by dialing: **1- (330) 220-4MTD (4683)**  
or  
**1- (800)-800-7310**
- Please have your model number and serial number ready when you call.
- Although both numbers are important, you will be asked to enter only your *serial* number before your call can be processed.

---

## SECTION 3: IMPORTANT SAFE OPERATION PRACTICES



**WARNING:** THIS SYMBOL POINTS OUT IMPORTANT SAFETY INSTRUCTIONS WHICH, IF NOT FOLLOWED, COULD ENDANGER THE PERSONAL SAFETY AND/OR PROPERTY OF YOURSELF AND OTHERS. READ AND FOLLOW ALL INSTRUCTIONS IN THIS MANUAL BEFORE ATTEMPTING TO OPERATE YOUR SNOW THROWER. FAILURE TO COMPLY WITH THESE INSTRUCTIONS MAY RESULT IN PERSONAL INJURY. WHEN YOU SEE THIS SYMBOL- HEED ITS WARNING.



**WARNING:** The Engine Exhaust from this product contains chemicals known to the State of California to cause cancer, birth defects or other reproductive harm.



**DANGER:** Your snow thrower was built to be operated according to the rules for safe operation in this manual. As with any type of power equipment, carelessness or error on the part of the operator can result in serious injury. If you violate any of these rules, you may cause serious injury to yourself or others.

### 1. TRAINING

- Read this operator's manual carefully in its entirety before attempting to assemble or operate this machine. Be completely familiar with the controls and the proper use of this machine before operating it. Keep this manual in a safe place for future and regular reference and for ordering replacement parts.
- Never allow children under 14 years old to operate a snow thrower. Children 14 years old and over should only operate snow thrower under close parental supervision. Only persons well acquainted with these rules of safe operation should be allowed to use your snow thrower.
- No one should operate this unit while intoxicated or while taking medication that impairs the senses or reactions.
- Keep the area of operation clear of all persons, especially small children and pets.
- Exercise caution to avoid slipping or falling, especially when operating in reverse.
- Before working with gasoline, extinguish all cigarettes and other sources of ignition. Check the fuel before starting the engine. Gasoline is an extremely flammable fuel. Do not fill the gasoline tank indoors, while the engine is running, or until engine has been allowed to cool at least two minutes. Replace gasoline cap securely and wipe off any spilled gasoline before starting the engine as it may cause a fire or explosion.
- Use a grounded three wire plug-in for all units with electric drive motors or electric starting motors.
- Adjust collector housing height to clear gravel or crushed rock surface.
- Never attempt to make any adjustments while engine is running (except where specifically recommended by manufacturer).
- Let engine and machine adjust to outdoor temperature before starting to clear snow.
- Always wear safety glasses or eye shields during operation or while performing an adjustment or repair, to protect eyes from foreign objects that may be thrown from the machine in any direction.

### 1. PREPARATION

- Thoroughly inspect the area where the equipment is to be used and remove all door mats, sleds, boards, wires and other foreign objects.
- Disengage all clutches and shift into neutral before starting engine.
- Do not operate equipment without wearing adequate winter outer garments. Do not wear jewelry, long scarfs or other loose clothing which could become entangled in moving parts. Wear footwear which will improve footing on slippery surfaces.

### 2. OPERATION

- Do not put hands or feet near or under rotating parts. Keep clear of discharge opening and auger at all times.
- Exercise extreme caution when operating on or crossing gravel drives, walks, or roads. Stay alert for hidden hazards or traffic. Do not carry passengers.
- After striking a foreign object, stop the engine, remove wire from spark plug, and thoroughly inspect the snow thrower for any damage. Repair the damage before restarting and operating the snow thrower.

- If the snow thrower should start to vibrate abnormally, stop the engine and check immediately for the cause. Vibration is generally a warning of trouble.
- Stop engine whenever you leave the operating position, before unclogging the collector/impeller housing or discharge guide, and making any repairs, adjustments, or inspections. Never place your hand in the discharge or collector openings. Use a stick or wooden broom handle to unclog the discharge opening.
- Take all possible precautions when leaving the unit unattended. Disengage the collector/impeller, stop the engine, and remove the key.
- When cleaning, repairing, or inspecting, make certain collector/impeller and all moving parts have stopped. Disconnect spark plug wire and keep away from plug to prevent accidental starting.
- Do not run engine indoors, except when starting engine and transporting snow thrower in or out of building. Open doors. Exhaust fumes are dangerous.
- Do not clear snow across the face of slopes. Exercise extreme caution when changing direction on slopes. Do not attempt to clear steep slopes.
- Never operate snow thrower without guards, plates, or other safety protection devices in place.
- Never operate snow thrower near glass enclosure, automobiles, window wells, drop off, etc., without proper adjustments of snow thrower discharge angle. Keep children and pets away.
- Do not overload machine capacity by attempting to clear snow at too fast a rate.

- Never operate the machine at high transport speeds on slippery surfaces. Look behind and use care when backing.
- Never direct discharge at bystanders or allow anyone in front of unit.
- Disengage power to collector/impeller when transporting or not in use.
- Use only attachments and accessories approved by the manufacturer of snow thrower (such as wheel weights, counter weights, cabs, etc.).
- Never operate the snow thrower without good visibility or light. Always be sure of your footing and keep a firm hold on the handles. Walk, never run.
- Muffler and engine become hot and can cause a burn. Do not touch.

### 3. MAINTENANCE AND STORAGE

- Check shear bolts, engine mounting bolts, etc., at frequent intervals for proper tightness to be sure equipment is in safe working condition.
- Never store the machine with fuel in the fuel tank inside a building where ignition sources are present, such as hot water and space heaters, clothes dryers, and the like. Allow engine to cool before storing in any enclosure.
- Always refer to operator's manual instructions for important details if snow thrower is to be stored for an extended period.
- Run machine a few minutes after throwing snow to prevent freeze up of collector/impeller.
- Check clutch controls periodically to verify they engage and disengage properly and readjust if necessary. Refer to operator's manual for adjustment instructions.



**WARNING - YOUR RESPONSIBILITY:** Restrict the use of this power machine to persons who read, understand and follow the warnings and instructions in this manual and on the machine.

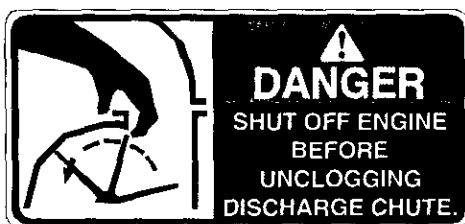
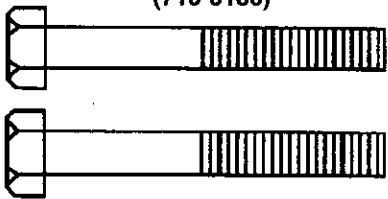
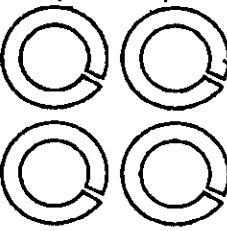
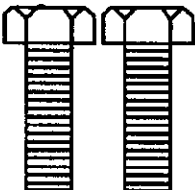
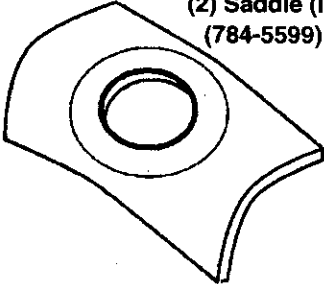

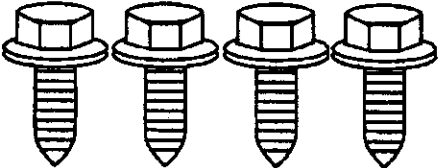
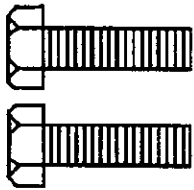

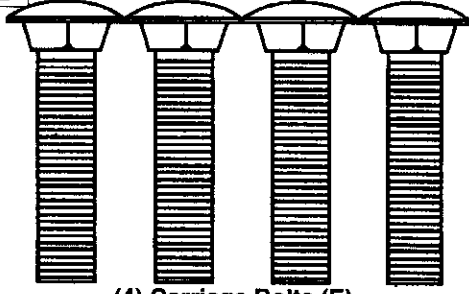

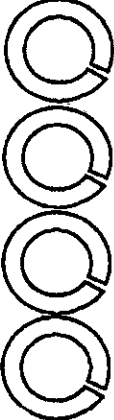



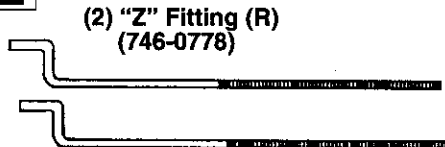

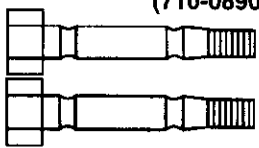
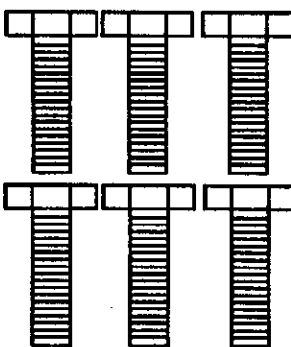
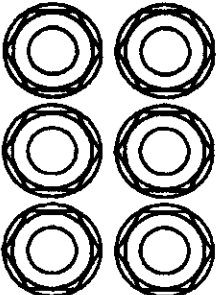

Figure 2

## SECTION 4: CONTENTS OF HARDWARE PACK

Lay out the hardware according to the illustration for identification purposes. Part numbers are shown in parentheses. (Hardware pack may contain extra items which are not used on your unit.)

<p><b>A ATTACHING THE HANDLES</b></p> <p>(2) Hex Bolts (A) (710-3180)</p>  <p>(4) Lock Washers (C) (736-0119)</p>  <p>(2) Hex Bolts (B) 710-3008</p>  <p>(2) Saddle (I) (784-5599)</p> 	<p><b>B ATTACHING THE CLUTCH GRIPS</b></p>  <p>(4) Hex Nuts (D) (712-3010)</p>
<p><b>D ATTACHING THE SPEED SELECTOR PLATE AND SHIFT LEVER</b></p>  <p>(4) Self-Tapping Screws (F) (710-0599)</p> <p>(2) Hex Bolts (G) (712-3015)</p>  <p>(2) Hex Lock Nuts (H) (712-3027)</p> 	<p><b>C ATTACHING THE HANDLE PANEL</b></p>  <p>(4) Carriage Bolts (E) (710-0262)</p>  <p>(4) Hex Nuts (D) (712-3010)</p>  <p>(4) Lock Washers (C) (736-0119)</p>
<p><b>G ATTACHING THE CHUTE DIRECTIONAL CONTROL ASSEMBLY</b></p>  <p>Cupped Washer (N) (736-0242)</p> <p>(2) Hex Nuts (D) (712-3010)</p>  <p>(2) Flat Washers (S) (736-0185)</p>  <p>Hair-Pin Clip (T) (714-0104)</p> 	<p><b>E ATTACHING THE CONTROL CABLES</b></p> <p>(2) "Z" Fitting (R) (746-0778)</p>  <p>(2) Hex Nuts (J) (712-0121)</p> 
<p><b>H AUGER SHEAR BOLTS (SPARES)</b></p> <p>(2) Hex Lock Nuts (712-0429)</p>  <p>(2) Shear Bolts (710-0890A)</p> 	<p><b>F ATTACHING THE CHUTE ASSEMBLY</b></p>  <p>(6) Hex Bolts (K) (710-3015)</p>  <p>(6) Hex Lock Nuts (M) (712-3027)</p> <p>(3) Chute Flange Keepers (Not Shown) (731-0851)</p>

**NOTE:** The augers are secured to the spiral shaft with two shear bolts and hex lock nuts. If you hit a hard foreign object or an ice jam, the snow thrower is designed so that the bolts may shear. Two replacement shear bolts and nuts are provided for your convenience. Store in a safe place until needed.

## SECTION 5: ASSEMBLY INSTRUCTIONS

**IMPORTANT:** After assembly, service engine with gasoline, and check oil level as instructed in the separate engine manual packed with your unit.

**NOTE:** References to right or left side of the snow thrower are determined from behind the unit in the operating position.

### UNPACKING

- Remove staples or break glue on the top flaps of the carton. Remove any loose parts included with unit (i.e., operator's manual, etc.).
- Cut corner's and lay end of carton down flat. Remove packing material.

- Roll unit out of carton. Check carton thoroughly for loose parts before discarding.

### TOOLS REQUIRED FOR ASSEMBLY

- Two adjustable wrenches

### LOOSE PARTS IN CARTON See Figure 3

A	(2)	Handles (Right and Left)
B	(1)	Pivot Rod
C	(1)	Cover Tube
D	(2)	Clutch Grips (Right and Left)
E	(1)	Handle Panel
F	(1)	Speed Selector Plate
G	(1)	Shift Lever
H	(1)	Chute Directional Control Assembly
J	(1)	Chute Assembly

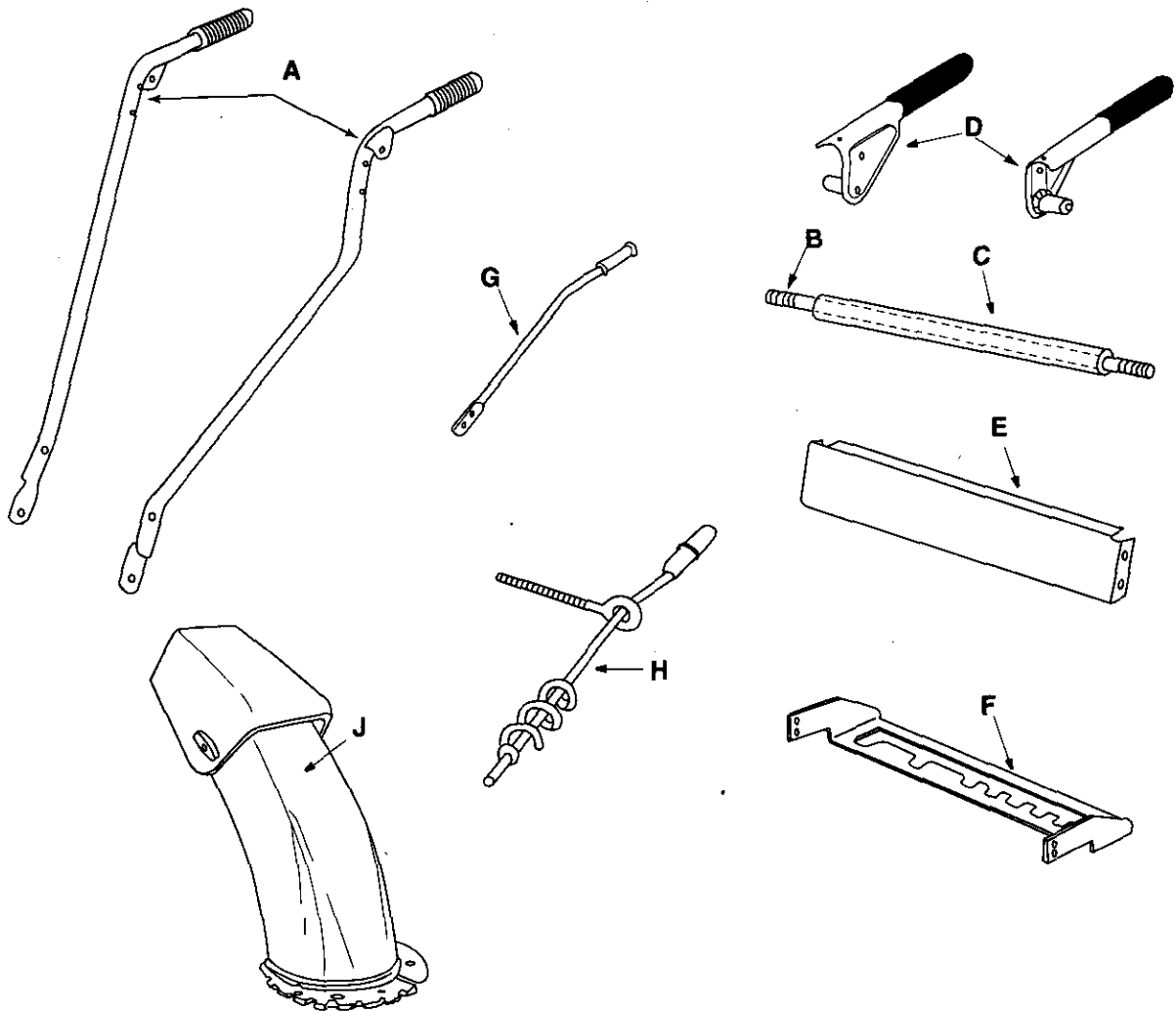

Figure 3

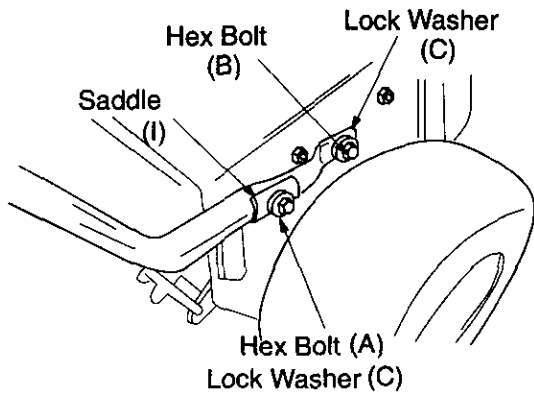

Figure 4

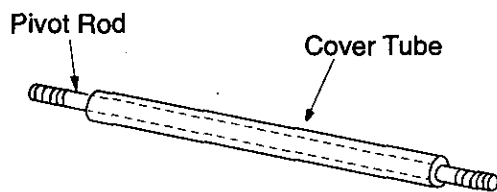

Figure 5

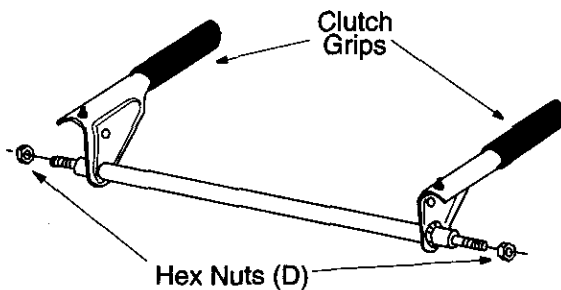

Figure 6

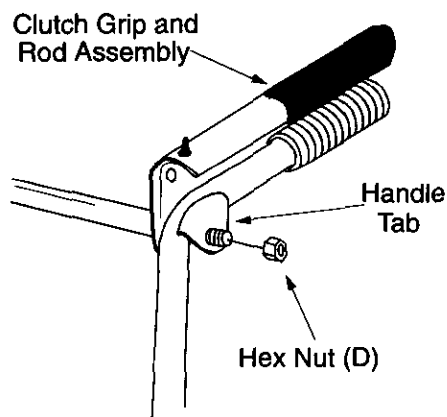

Figure 7

## ATTACHING THE HANDLES (Hardware A)

1. Place right handle in position against the snow thrower so the flat side of the handle is against the frame. Secure bottom hole in handle to snow thrower using hex bolt (B) and lock washer (C). There are weld nuts welded to the inside of the frame for these bolts. See Figure 4. Do not tighten at this time.
2. Attach the left handle in the same manner. Do not tighten at this time.
3. Place saddle (I) over upper holes on handles (curve matching curve on handle). Secure to the frame with lock washers (C) and hex bolts (A). See Figure 4. Do not tighten at this time.

## ATTACHING THE CLUTCH GRIPS (Hardware B)

1. Slide the pivot rod into the cover tube as shown in Figure 5. The pivot rod and cover tube may already be assembled.
2. Place the clutch grips in position on the rod so the flat side of the clutch grips are against the pivot rod cover. Thread hex nuts (D) onto each end of the rod. Tighten nuts allowing the clutch grips to move freely on pivot rod. See Figure 6.
3. Insert clutch grip and rod assembly into handle tabs. Clutch grips must sit on top of the handles. Thread hex nuts (D) on each end to hold into position. Do not tighten. See Figure 7.

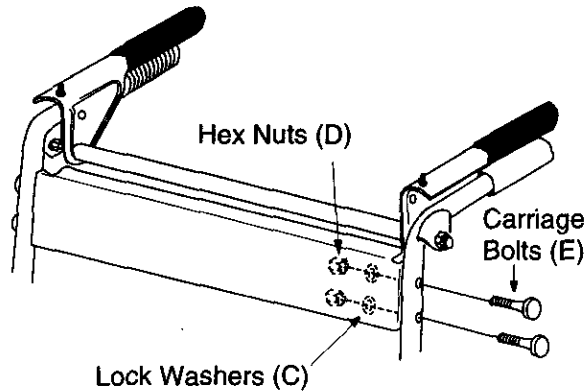

Figure 8

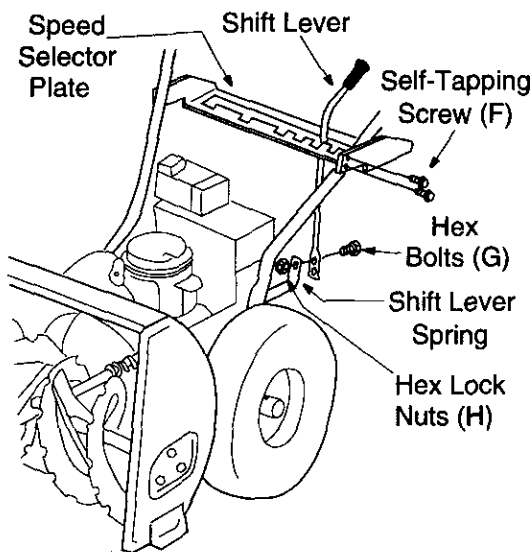

Figure 9

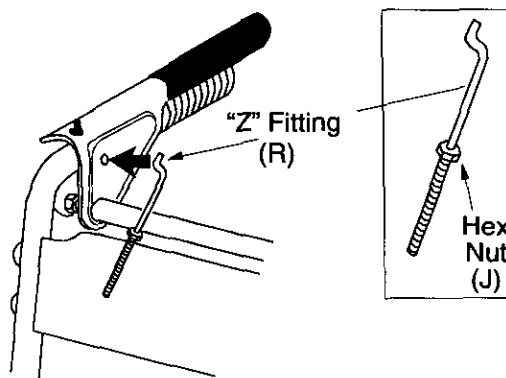

Figure 10

## ATTACHING THE HANDLE PANEL (Hardware C)

Position the handle panel between handles. Insert carriage bolts (E) and secure with lock washers (C) and hex nuts (D). See Figure 8.

## ATTACHING SPEED SELECTOR PLATE AND SHIFT LEVER (Hardware D)

1. Assemble the speed selector plate to the **outside** of the handles as shown in Figure 9. Secure using four self-tapping screws (F).
2. Insert the shift lever through slot in the speed selector plate.

**NOTE:** The bend in the lever should be towards the operator. Secure shift lever to the shift lever spring using two hex bolts (G) and hex lock nuts (H). Tighten both bolts finger tight. At this point the shift lever and shift lever spring are not against each other. As you tighten the bolts and nuts with two wrenches they will pull together. See Figure 9.

3. Tighten all hardware assembled to this point. **CLUTCH GRIPS MUST MOVE FREELY.**

## ATTACHING THE CONTROL CABLES (Hardware E)

1. Thread hex nuts (J) onto the "Z" fittings (R) (see inset, Figure 10). Insert "Z" fitting into hole in clutch grips.
2. Route the left cable between engine and speed selector plate and then between handle panel and clutch lever pivot rod before threading onto the left "Z" fitting. Assemble the right cable using the same route.
3. Correct adjustment on cables is minimal slack but not tight. Tighten hex nuts when adjustment is correct.

**NOTE:** If the right hand lockout cable is not adjusted correctly, the wheels will tend to turn. If the left hand lockout cable is not adjusted correctly, the augers will not stop rotating.



**WARNING:** There must not be any tension on either control cable with the traction control or auger control grip in the disengaged (up) position. These clutches are a safety feature, and their function can be overridden if there is tension on either cable with the clutches disengaged.



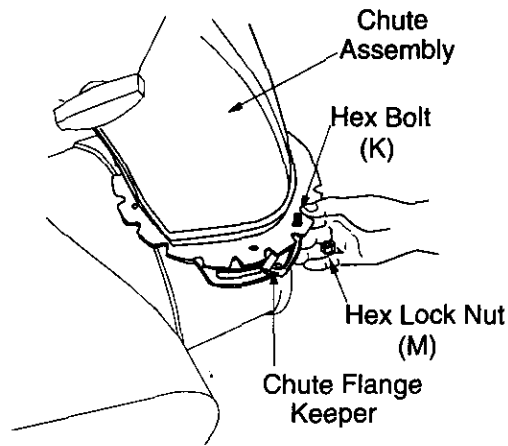

Figure 11

## ATTACHING THE CHUTE ASSEMBLY (Hardware F)

1. Place chute assembly over chute opening, with the opening in the chute assembly facing the front of the unit. Place chute flange keepers beneath lip of chute assembly, with the flat side of chute flange keeper facing downward.
2. Insert hex bolt (K) up through chute flange keeper and chute assembly as shown in Figure 11. Secure with hex lock nut (M). After assembling all three chute flange keepers, tighten all nuts and bolts securely. Do not **overtighten**.

**Note:** Locknuts cannot be threaded onto a bolt by hand. Tighten with 2 7/16" wrenches. This type of nut is used where vibration occurs.

## ATTACHING THE CHUTE DIRECTIONAL CONTROL (Hardware G)

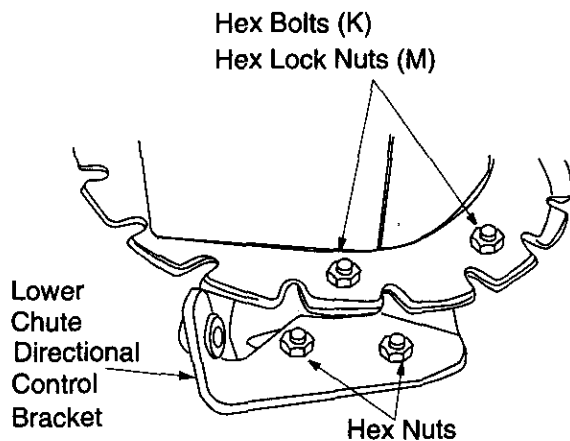

Figure 12

1. Loosen the two hex nuts which secure the lower chute directional control support bracket (see Figure 12) to the snow thrower housing.
2. Place one flat washer (T) over the end of the chute directional control, then insert the end of the chute directional control into the hole in the plastic bushing in the chute bracket. See Figure 13. Place second flat washer (T) on chute directional control, and secure with hairpin clip (S).
3. Thread one hex nut (D) onto the eyebolt on the chute directional control assembly until there is at least two inches of threads showing between the nut and the head of the eyebolt. See Figure 14.
4. Place the eyebolt into the hole located half way up the left handle. Secure with cupped washer (N) (cupped side against the handle, see inset, Figure 14) and hex nut (D).
5. Adjust the chute directional control support bracket (see Figure 13) so that the spiral on the chute directional control fully engages the teeth on the chute assembly. Tighten the hex nuts on the lower chute directional control bracket securely. Tighten the hex nuts on the eyebolt.
6. Check to make sure all nuts and bolts on the control panel and all four bolts which secure the handles to the frame are tight.

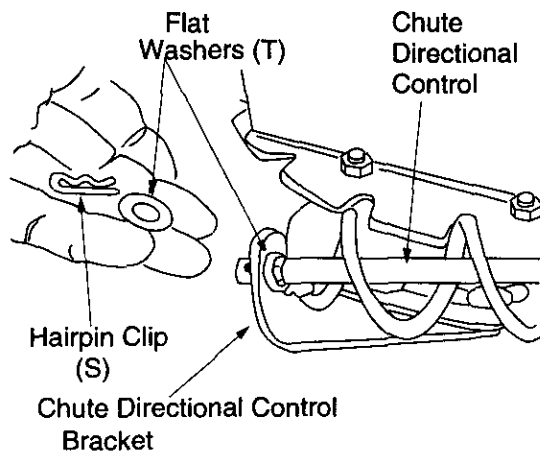

Figure 13

## FINAL ASSEMBLY AND ADJUSTMENTS

### Auger Control

To check the adjustment of the auger control, push forward on the left hand clutch grip (depress the rubber bumper). There should be slack in the cable. Release the clutch grip. The cable should be straight. Make certain you can depress the auger control grip against the left handle completely.

If necessary, loosen the hex lock nut and thread the cable in (for less slack) or out (for more slack) as necessary. Refer to Figure 15. Recheck the adjustment.

Tighten the lock nut against the cable when correct adjustment is reached.

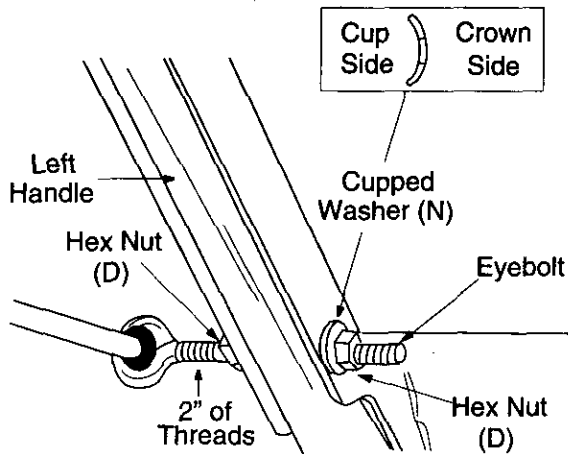

Figure 14

### Traction Control and Shift Lever Adjustment

To check the adjustment of the traction control and shift lever, move the shift lever all the way forward to sixth (6) position. With the traction control released, push the snow thrower forward. The unit should move forward freely. Then engage the traction control grip. The wheels should stop turning.

Now release the traction control grip, and push the unit again. Move the shift lever back to the fast reverse position, then all the way forward again. There should be no resistance in the shift lever, and the and the wheels should keep turning

If you have resistance when moving the shift lever or the wheels stop when they should not, loosen the jam nut on the traction control cable and unthread the cable one turn. If the wheels do not stop when you engage the traction control grip, loosen the jam nut on the traction control cable and thread the cable in one turn. Recheck the adjustment and repeat as necessary. Tighten the jam nut to secure the cable when correct adjustment is reached.

**NOTE:** If you are uncertain that you have reached the correct adjustment, refer to the Adjustment section.

### ADJUSTING THE SKID SHOES

The space between the shave plate and the ground can be adjusted.

For close snow removal on a smooth surface, raise the skid shoes into a high position on the auger housing.

Use a middle or lower position when the area to be cleared is uneven. See Figure 16.

Adjust skid shoes by loosening the four hex nuts and carriage bolts and moving skid shoes to desired position.

Make certain the entire bottom surface of skid shoe is against the ground to avoid uneven wear on the skid shoes. Retighten nuts and bolts securely.

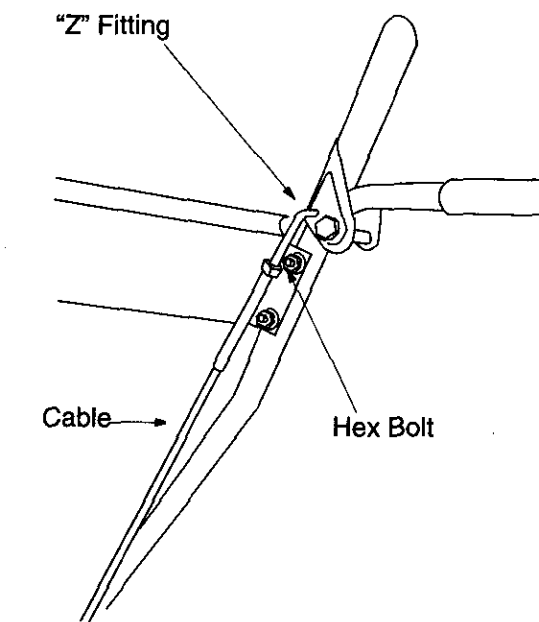

Figure 15

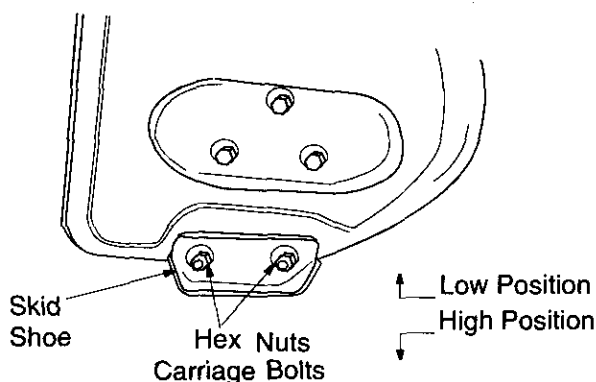

Figure 16

## TIRE PRESSURE (Pneumatic Tires)

The tires are overinflated for shipping purposes. Check tire pressure and reduce to 15 to 20 psi. Refer to tire sidewalls for recommended tire pressure.

**NOTE:** If the tire pressure is not equal in both tires, the unit may pull to one side or the other.

## SECTION 6: CONTROLS

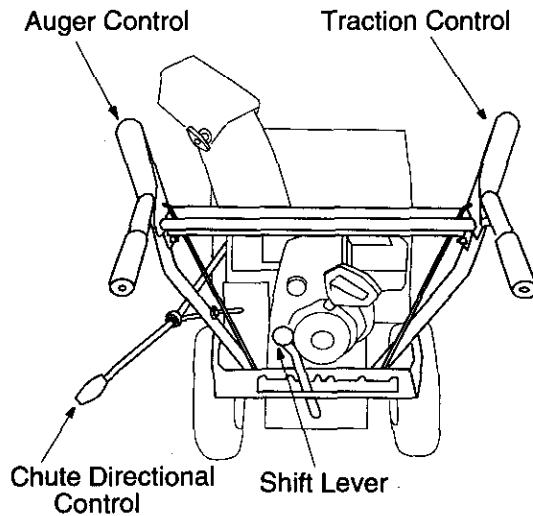

Figure 17

### SHIFT LEVER

The shift lever is located below the handle panel. The shift lever may be moved into one of seven positions. Run engine with throttle in the fast position. Use the shift lever to determine ground speed. See Figure 17.

Forward—one of five speeds. Position number one (1) is the slowest. Position number five (5) is the fastest.

Reverse—two reverse speeds; R1 and R2. R2 is the faster reverse speed.

### AUGER CONTROL

The auger control is located on the left handle. Squeeze the auger control grip to engage the augers. Release to stop the snow throwing action. See Figure 17.

### TRACTION CONTROL

The traction control is located on the right handle. Squeeze the traction control grip to engage the wheel drive. Release to stop. See Figure 17.

## CHUTE DIRECTIONAL CONTROL

The chute directional control is located on left hand side of the snow thrower. See Figure 17.

To change the direction in which snow is thrown, turn chute directional control as follows:

- Crank clockwise to discharge to the left.
- Crank counterclockwise to discharge to the right.

## THROTTLE CONTROL

The throttle control is located on the engine. It regulates the speed of the engine. See Figure 18.

## SAFETY IGNITION KEY

The ignition key must be inserted in the switch before the unit will start. Remove the ignition key when snow thrower is not in use. Do not turn ignition key. See Figure 18.

## FUEL CUTOFF VALVE

The fuel cutoff valve, located under the fuel tank, controls fuel flow from tank.

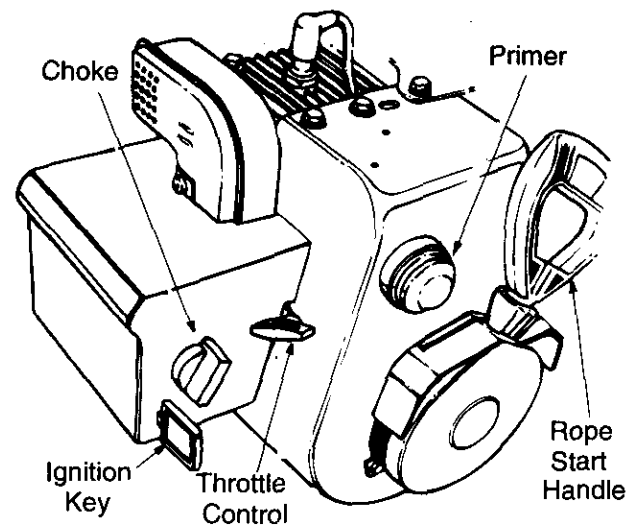
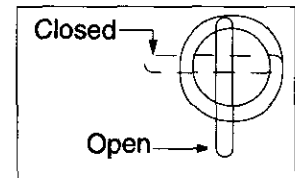

Figure 18

## SECTION 7: OPERATION

### BEFORE STARTING



**WARNING:** Observe all Warning Labels on the snow thrower prior to use. See Figure 2.

Your snow thrower is shipped with oil; however, you must check the oil level before operating. Be careful not to overfill.

The spark plug wire was disconnected for safety. Attach spark plug wire to spark plug before starting.

### GAS AND OIL FILL-UP

Check oil level and add oil if necessary. Service the engine with gasoline as instructed in the separate engine manual packed with your snow thrower. Read instructions carefully.



**WARNING:** Never fill fuel tank indoors. Never fill fuel tank with engine running or while engine is hot. Do not smoke when filling fuel tank.

### TO START ENGINE

1. Attach spark plug wire to spark plug. Make certain the metal loop on the end of the spark plug wire (inside the boot) is fastened securely over the metal tip on the spark plug. See Figure 19.

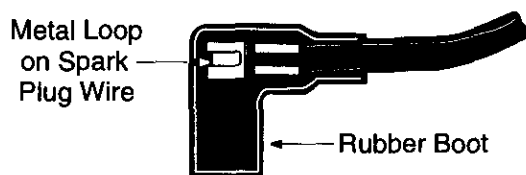
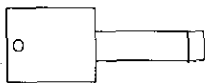

Figure 19

2. Make certain the fuel cutoff valve is in the OPEN (vertical) position.
3. Make certain the auger and drive clutch levers are in the disengaged (released) position.
4. Move throttle control up to FAST position. Insert ignition key into slot. See Figure 20. Be certain it snaps into place. Do not turn key

ENGINE WILL NOT START UNLESS IGNITION KEY IS INSERTED INTO IGNITION SLOT IN CARBURETOR COVER. DO NOT TURN IGNITION KEY.



### Electric Starter: (If Equipped)



**WARNING:** The optional electric starter is equipped with a three-wire power cord and plug, and is designed to operate on 120 volt AC household current. It must be properly grounded at all times to avoid the possibility of electric shock which may be injurious to the operator. Follow all instructions carefully. Determine that your house wiring is a three wire grounded system. Ask a licensed electrician if you are not certain. If your house wiring system is not a three-wire grounded system, do not use this electric starter under any conditions. If your system is grounded and a three-hole receptacle is not available at the point your starter will normally be used, one should be installed by a licensed electrician.

When connecting the power cord, always connect cord to starter on engine first, then plug the other end into a three-hole grounded receptacle.

When disconnecting the power cord, always unplug the end from the three-hole grounded receptacle first.

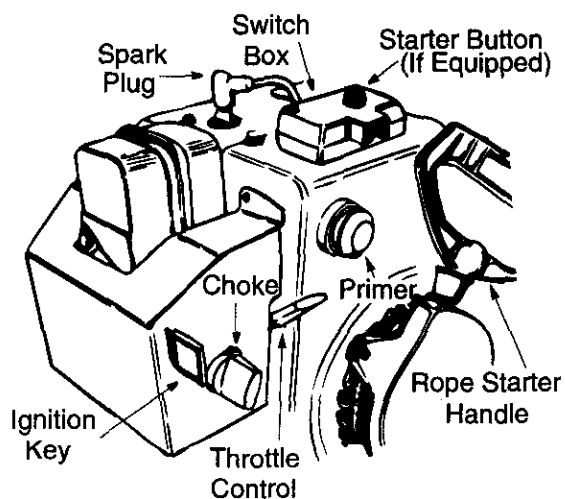

Figure 20

1. Rotate choke knob to OFF position.
2. Connect power cord to switch box on engine. Plug the other end of power cord into a three-hole, grounded 12-volt AC receptacle.
3. Push starter button to crank engine. See Figure 20. As you crank the engine, move choke knob to FULL choke position.

4. When engine starts, release starter button, and move choke gradually to OFF. If engine falters, move choke immediately to FULL and then gradually to OFF.

### Recoil Starter:

1. Rotate choke knob to FULL choke position (cold engine start).
2. If engine is warm, place choke in OFF position instead of FULL.
3. Push primer button two or three times for cold engine start. See Figure 20.
4. If engine is warm, push primer button once only.

**NOTE:** Always cover vent hole in primer button when pushing. Additional priming may be necessary for first start if temperature is below 15 degrees Fahrenheit.

5. Grasp starter handle (see Figure 20) and pull rope out slowly, until it pulls slightly harder. Let rope rewind slowly.
6. Pull starter handle rapidly. Do not allow handle to snap back. Allow it to rewind slowly while keeping a firm hold on the starter handle.
7. Repeat step 8 until engine starts.
8. As engine warms up and begins to operate evenly, rotate choke knob slowly to OFF position. If engine falters, return to FULL choke, then slowly move to OFF position.

### TO STOP ENGINE

1. Run engine for a few minutes before stopping to help dry off any moisture on the engine.
2. To help prevent possible freeze up of starter, proceed as follows.
  - **Electric Starter (If Equipped):** Connect power cord to switch box on engine, then to 120 volt AC receptacle. With the engine running, push starter button and spin the starter for several seconds. The unusual sound made by spinning the starter will not harm engine or starter. Disconnect the power cord from receptacle first, and then from switch box.
  - **Recoil Starter:** With engine running, pull starter rope with a rapid, continuous full arm stroke three or four times. Pulling the starter rope will produce a loud clattering sound, which is not harmful to the engine or starter.
3. To stop engine, move throttle control to "stop" or "off" position.
4. Remove the ignition key. Do not turn key. Disconnect the spark plug wire from the spark plug to prevent accidental starting while equipment is unattended.

**NOTE:** Do not lose ignition key. Keep it in a safe place. Engine will not start without the ignition key.

5. Wipe all snow and moisture from the carburetor cover in the area of the control levers. Also, move control levers back and forth several times.

### TO ENGAGE DRIVE

1. With the engine running near top speed, move shift lever into one of the five FORWARD positions or two REVERSE positions. Select a speed appropriate for the snow conditions that exist. Use the slower speeds until you are familiar with the operation of the snow thrower.
2. Squeeze the auger control grip and the augers will turn. Release it and the augers will stop.
3. Squeeze the traction control grip and the snow thrower will move. Release it and drive motion will stop.
4. NEVER move shift lever without releasing drive clutch.

### TO ENGAGE AUGERS

To engage the augers and start the snow throwing action, squeeze the auger control grip against the left handle. Release to stop the augers.

### TIRE CHAINS (Optional Equipment)

Tire chains should be used whenever extra traction is needed.

### OPERATING TIPS

**NOTE:** Allow the engine to warm up for a few minutes as the engine will not develop full power until it reaches operating temperature.



**WARNING:** Temperature of muffler and surrounding areas may exceed 150 degrees Fahrenheit. Avoid these areas.

1. For most efficient snow removal, remove snow immediately after it falls.
2. Discharge snow downwind whenever possible. Slightly overlap each previous swath.
3. Set the skid shoes 1/4" below the scraper bar for normal usage. The skid shoes may be adjusted upward for hard-packed snow. Adjust downward when using on gravel or crushed rock.
4. Be certain to follow the precautions listed under "To Stop Engine" to prevent possible freeze-up.
5. Clean the snow thrower thoroughly after each use.

## SECTION 8: ADJUSTMENTS



**WARNING:** NEVER attempt to clean chute or make any adjustments while engine is running.

### CHUTE ASSEMBLY ADJUSTMENT

The distance snow is thrown can be controlled by adjusting the angle of the top section of the chute assembly.

### SKID SHOE ADJUSTMENT

The space between the shave plate and the ground can be adjusted. Refer to the Final Assembly and Adjustments section.

### TRACTION CONTROL ADJUSTMENT

Refer to the Final Assembly and Adjustments section to adjust the traction control. If you are uncertain that you have reached the correct adjustment, the adjustment can be physically checked as follows.

1. With the snow thrower tipped forward (be certain to drain the oil gasoline or drain the oil and place plastic film under the gas cap if the snow thrower has already been operated), remove the frame cover underneath the snow thrower by removing six self-tapping screws.
2. With the traction control released, there must be clearance between the friction wheel and the drive plate in all positions of the shift lever. With the traction control engaged, the friction wheel must contact the drive plate. See Figure 21.

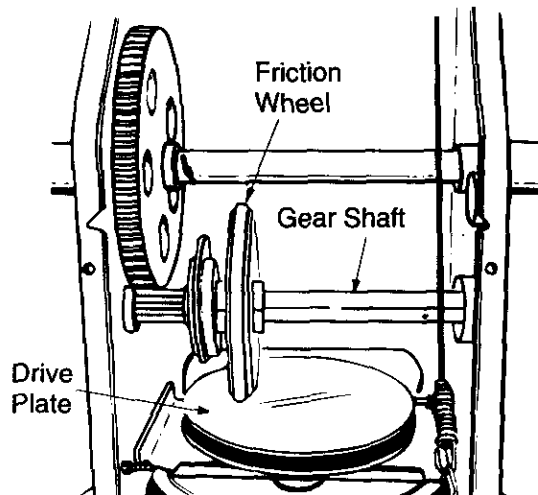

Figure 21

3. If adjustment is necessary, loosen the lock nut on the traction control cable and thread the cable in or out as necessary. Tighten the lock nut to secure the cable when correct adjustment is reached. Reassemble the frame cover.

**NOTE:** If you placed plastic under the gas cap, be certain to remove it.

### AUGER CONTROL ADJUSTMENT

To adjust the auger clutch, refer to Final Assembly and Adjustments in section 5.

### CARBURETOR ADJUSTMENT



**WARNING:** If any adjustments are made to the engine while the engine is running (e.g. carburetor), keep clear of all moving parts. Be careful of heated surfaces and muffler.

Minor carburetor adjustment may be required to compensate for differences in fuel, temperature, altitude and load.

Refer to the separate engine manual packed with your unit for carburetor adjustment information.

### DRIVE WHEELS

The wheels may be adjusted for two different methods of operation. The adjustment is made by placing the click pins in one of two different holes on the right side of the unit. See Figure 22.

1. One Wheel Driving—On the right side of the unit, place click pin in the outside axle hole only. Do not place pin through wheel hub. This position gives power drive to the left wheel only, making the unit easier to maneuver.
2. Both Wheels Driving—Rotate wheel assembly to align hole in hub with inner hole on axle shaft. Insert click pin in hole. Outer axle shaft hole should be visible. See Figure 22.

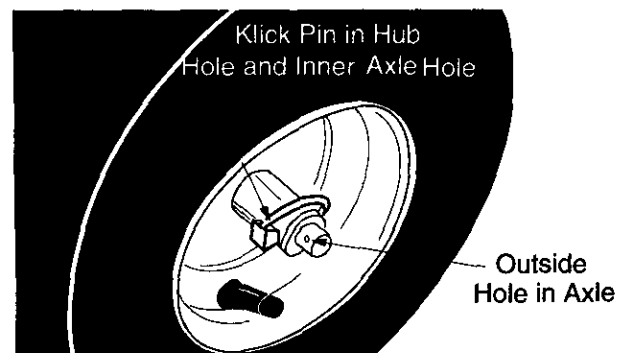

Figure 22

## SECTION 9: LUBRICATION



**WARNING:** Disconnect the spark plug wire and ground against the engine before performing any repairs or maintenance.

### ENGINE

Refer to engine manual for engine lubrication instructions.



**WARNING:** When following instructions in separate engine manual for draining oil, be sure to protect frame to avoid oil dripping onto transmission parts.

### WHEELS

Oil or spray lubricant into bearings at wheels at least once a season. Pull klick pin, remove wheels, clean and coat axles with a multipurpose automotive grease. See Figure 23.

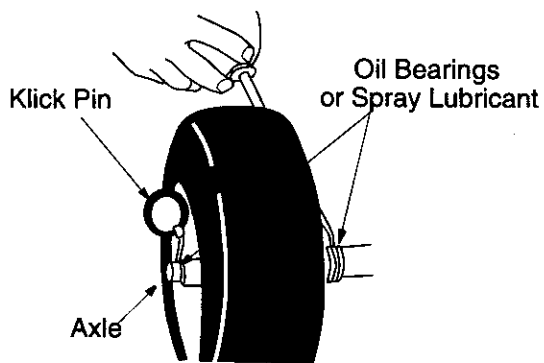

Figure 23

### CHUTE DIRECTIONAL CONTROL

The worm gear on the chute control should be greased with multipurpose automotive grease.

### AUGER SHAFT

At least once a season, remove shear bolts on auger shaft. Oil or spray lubricant inside shaft and lubricate the auger bearings. See Figure 24.

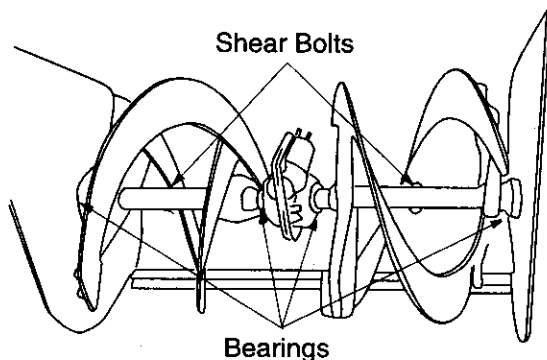

Figure 24

### GEAR SHAFT

Lubricate the gear shaft with a good all-weather multi-purpose light grease at least once a season or after every 25 hours of operation.

**IMPORTANT:** Keep all grease and oil off of the friction wheel and drive plate.

### DRIVE AND SHIFTING MECHANISM

Remove rear cover. Oil any chains, sprockets, gears, bearings, shafts, and shifting mechanism at least once a season. Use engine oil or a spray lubricant. Avoid getting oil on rubber friction wheel and aluminum drive plate.

### GEAR CASE

The worm gear case has been filled with grease at the factory. If disassembled for any reason, lubricate with 2 ounces of shell grease, part number 737-0168.

**IMPORTANT:** Do not overfill the gear case. Damage to the seals could result. Be sure the vent plug is free of grease in order to relieve pressure.

## SECTION 10: MAINTENANCE



**WARNING:** Disconnect the spark plug wire and ground against the engine before performing any repairs or maintenance.

### ENGINE

Refer to separate engine manual for all engine maintenance procedures.

### AUGERS

The augers are secured to the spiral shaft with two shear bolts and hex lock nuts. See Figure 24. If you hit a hard foreign object or ice jam, the snow thrower is designed so that the bolts may shear.

If the augers will not turn, check to see if the bolts have sheared. Replacement shear bolts and hex lock nuts have been provided with the snow thrower. When replacing bolts, spray an oil lubricant into shaft before inserting new bolts.

### SHAVE PLATE AND SKID SHOES

The shave plate and skid shoes on the bottom of the snow thrower are subject to wear. They should be checked periodically and replaced when necessary.

- To remove skid shoes, remove the four carriage bolts, cupped washers and hex nuts which attach them to the snow thrower. Reassemble new skid shoes with the four carriage bolts, cupped washers (cupped side goes against skid shoes) and hex nuts.
- To remove shave plate, remove the carriage bolts, cupped washers and hex nuts which attach it to the snow thrower housing. Reassemble new shave plate, making sure heads of the carriage bolts are to the inside of the housing. Tighten securely.

## BELT REMOVAL AND REPLACEMENT



**WARNING:** Remove the spark plug wire from the spark plug and ground. Drain gasoline from the fuel tank, or place a piece of plastic film underneath the gas cap to prevent gasoline from leaking.

## AUGER BELTS

1. Remove the plastic belt cover on the front of the engine by removing the two self-tapping screws. See Figure 25.

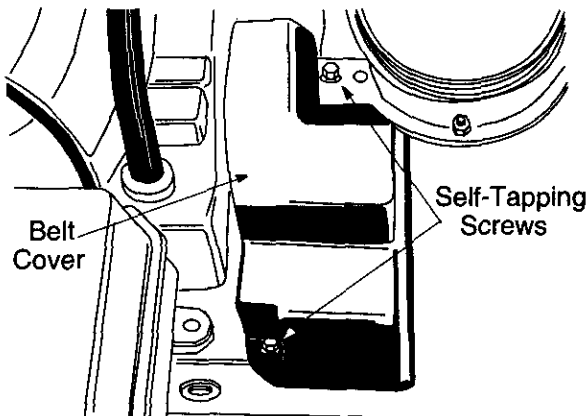

Figure 25

2. Drain the gasoline from the snow thrower, or place a piece of plastic under the gas cap.
3. Tip the snow thrower up and forward so that it rests on the housing.
4. Remove six self-tapping screws from the frame cover underneath the snow thrower.
5. Roll the auger belt off the engine pulley. See Figure 26.
6. Unhook the idler spring from the hex bolt on the auger housing. See Figure 27.

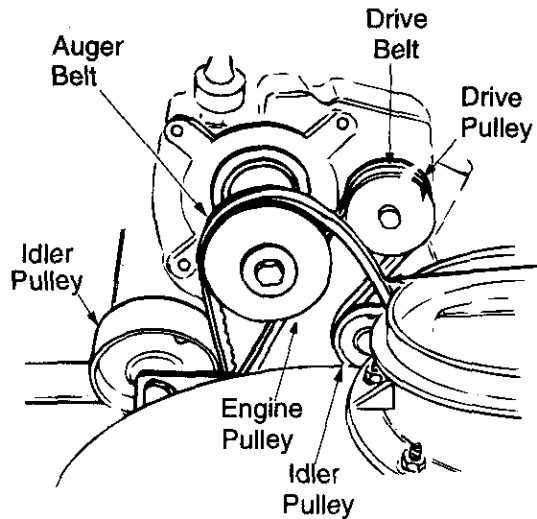

Figure 26

7. Unhook the support bracket spring from the frame.

**NOTE:** It may be necessary to loosen the six nuts that connect the frame to the auger housing to aid in belt removal.

8. Lift the rear auger belt from the auger pulley, and slip belt between the support bracket and the auger pulley. See Figure 26. Repeat this step for the front auger belt.
9. Replace both auger drive belts by following instructions in reverse order.

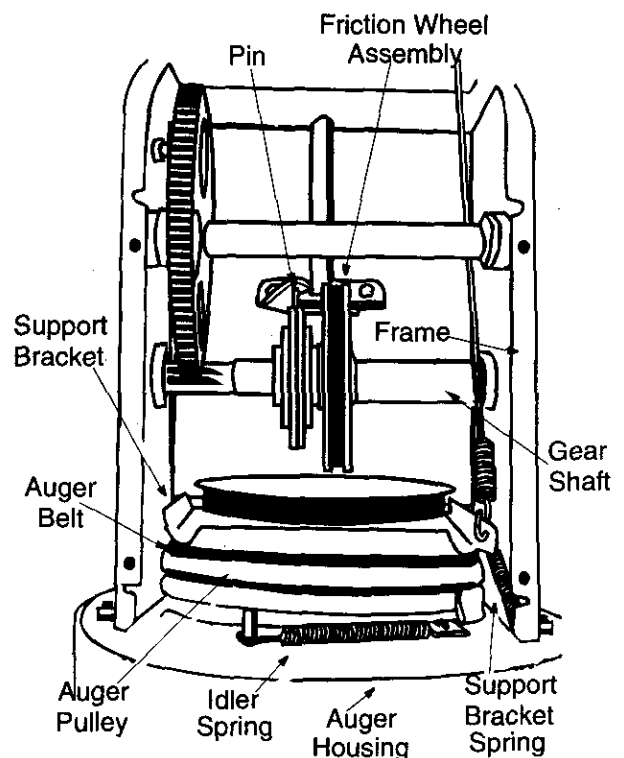

Figure 27



## DRIVE BELT

1. Follow steps 1 through 4 of previous instructions.
2. Pull idler pulley up, and lift belt off engine pulley and friction wheel disc. See Figure 26.
3. Using a wrench, loosen the nut on the stop bolt until the support bracket rests on the auger pulley. See Figure 28.
4. Slip belt between friction wheel and friction wheel disc. See Figure 28. Remove and replace belt. Reassemble following the instructions in reverse order.

**NOTE:** The support bracket must rest on the stop bolt after the new belt has been assembled. See Figure 28.

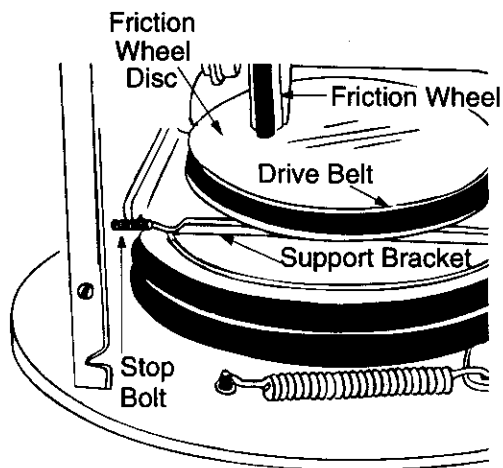

Figure 28

## CHANGING THE FRICTION WHEEL RUBBER

The rubber on the friction wheel is subject to wear and should be checked after 25 hours of operation, and periodically thereafter. Replace the friction wheel rubber if any signs of wear or cracking are found.

1. Drain the gasoline from the snow thrower, or place a piece of plastic under the gas cap.
2. Tip the snow thrower up and forward, so that it rests on the housing.

3. Remove six self-tapping screws from the frame cover underneath the snow thrower.
4. Remove the klick pins which secure the wheels, and remove the wheels from the axle.
5. Using a wrench to hold the shaft, loosen, but do not completely remove, the hex nut and bell washer on the left end of gear shaft. See Figure 29.
6. Lightly tap the hex nut to dislodge the ball bearing from the right side of the frame. Remove the hex nut and bell washer from the left end of shaft.
7. Slide the gear shaft to the right, then slide the friction wheel assembly from the shaft.
8. Remove the six screws from the friction wheel assembly (three from each side). Remove the friction wheel rubber from between the friction wheel plate.
9. Reassemble new friction wheel rubber to the friction wheel assembly, tightening the six screws in rotation and with equal force.
10. Slide friction wheel assembly back onto the gear shaft. Be sure to align the pin on the shift rod with the hole in the friction wheel assembly. See Figure 27. Reassemble in reverse order.

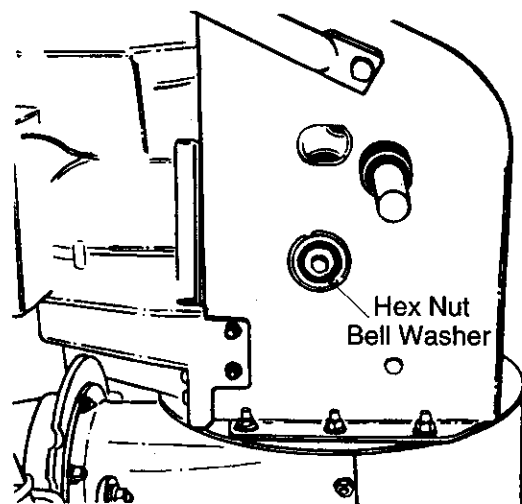

Figure 29

## SECTION 11: OFF-SEASON STORAGE



**WARNING:** Never store engine with fuel in tank indoors or in poorly ventilated areas, where fuel fumes may reach an open flame, spark or pilot light as on a furnace, water heater, clothes dryer or other gas appliance.

If unit is to be stored over 30 days, prepare for storage as follows:

1. Remove all gasoline from carburetor and fuel tank to prevent gum deposits from forming on these parts and causing possible malfunction of engine.
2. Run engine until fuel tank is empty and engine stops due to lack of fuel.
3. Drain carburetor by pressing upward on bowl drain, located below the carburetor cover.



**WARNING:** Drain fuel into approved container outdoors, away from open flame. Be certain engine is cool. Do not smoke. Fuel left in engine during warm weather deteriorates and will cause serious starting problems.

**NOTE:** Fuel stabilizer is an acceptable alternative in minimizing the formation of fuel gum deposits during storage. Add stabilizer to gasoline in fuel tank or storage container. Always follow mix ratio found on stabilizer container. Run engine at least 10 minutes after adding stabilizer to allow it to reach carburetor. Do not drain carburetor if using fuel stabilizer.

4. Remove all dirt from exterior of engine and equipment.
5. Remove spark plug and pour one (1) ounce of engine oil through spark plug hole into cylinder. Cover spark plug hole with rag. Crank engine several times to distribute oil. Replace spark plug.
6. Follow lubrication recommendations in section 9.

**NOTE:** When storing any type of power equipment in an unventilated or metal storage shed, care should be taken to rust proof the equipment. Using a light oil or silicone, coat the equipment, especially any chains, springs, bearings and cables.

## SECTION 12: Trouble Shooting Guide

Trouble	Possible Cause(s)	Corrective Action
Engine fails to start	Fuel tank empty, or stale fuel.  Blocked fuel line. Choke not in ON position Faulty spark plug. Key not in switch on engine. Spark plug wire disconnected. Primer button not depressed. Fuel shut-off valve closed (if so equipped).	Fill tank with clean, fresh gasoline. Fuel will not last over thirty days unless a fuel stabilizer is used. Clean fuel line. Move switch to ON position Clean, adjust gap or replace. Insert key. Connect spark plug wire.  Refer to the engine manual packed with your unit. Open fuel shut-off valve.
Engine runs erratic**	Unit running on CHOKE. Blocked fuel line or stale fuel.  Water or dirt in fuel system. Carburetor out of adjustment.	Move choke lever to OFF position. Clean fuel line; fill tank with clean fresh gasoline. Fuel will not last over thirty days unless a fuel stabilizer is used. Drain fuel tank. Refill with fresh fuel. Refer to the engine manual packed with your unit or have carburetor adjusted by an authorized service dealer.
Loss of power	Spark plug wire loose. Gas cap vent hole plugged. Exhaust port plugged.	Connect and tighten spark plug wire. Remove ice and snow from cap. Be certain vent hole is clear. Clean-see Maintenance section of engine manual.
Engine overheats	Carburetor not adjusted properly. Incorrect fuel mixture.	Refer to the engine manual packed with your unit or have carburetor adjusted by an authorized service dealer. Drain fuel tank. Refill with proper fuel mixture.
Excessive vibration	Loose parts or damaged auger.	Stop engine immediately and disconnect spark plug wire. Tighten all bolts and nuts. Make all necessary repairs. If vibration continues, have unit serviced by an authorized service dealer.
Unit fails to propel itself	Incorrect adjustment of drive cable. Drive belt loose or damaged.	Adjust drive cable. Refer to Adjustment section of this manual. Replace drive belt. Refer to Belt Replacement in Maintenance section of this manual.
Unit fails to discharge snow	Discharge chute clogged.  Foreign object lodged in auger. Incorrect adjustment of drive cable. Drive belt loose or damaged.	Stop engine immediately and disconnect spark plug wire. Clean discharge chute and inside of auger housing. Stop engine immediately and disconnect spark plug wire. Remove object from auger. Adjust drive cable. Refer to Adjustment section of this manual. Replace drive belt. Refer to Belt Replacement in Maintenance section of this manual.

**Note:** For repairs beyond the minor adjustments above, contact your local authorized service dealer.

# Gear Assembly

## Model 611

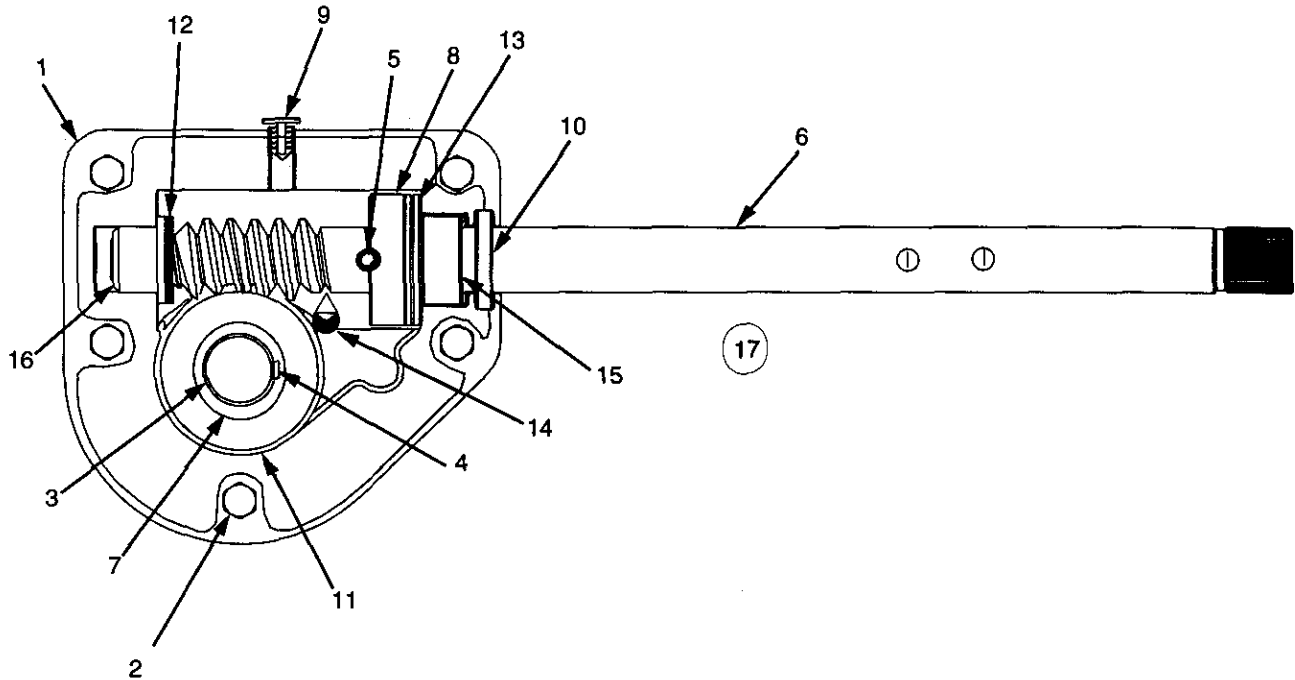

REF. NO.	PART NO.	DESCRIPTION	REF. NO.	PART NO.	DESCRIPTION
1	618-0123	Housing—R.H.	9	721-0325	Plug
	618-0124	Housing—L.H.	10	721-0327	Seal-Oil
2	710-0642	Hex Screw 1/4-20 x .75	11	736-0351	Washer-Flat
3	711-1020	Spiral Axle 22"	12	736-0369	Washer-Flat
	711-0908	Spiral Axle 24"	13	736-0445	Washer-Flat
4	714-0161	Key	14	737-0168	Grease
5	715-0143	Pin-Spiral	15	741-0662	Bearing-Flange
6	717-0526	Shaft-Worm	16	741-0663	Bearing-Flange
7	717-0528	Gear-Worm	17	618-0152	Ass'y. Complete 22"
8	718-0186	Collar-Thrust		618-0120	Ass'y Complete 24"

# Engine and V-Belts

## Model 611

**IMPORTANT:** For a proper working machine, use Factory Approved Parts.

**V-BELTS** are specially designed to engage and disengage safely. A substitute (non OEM) V-Belt can be dangerous by not disengaging completely.

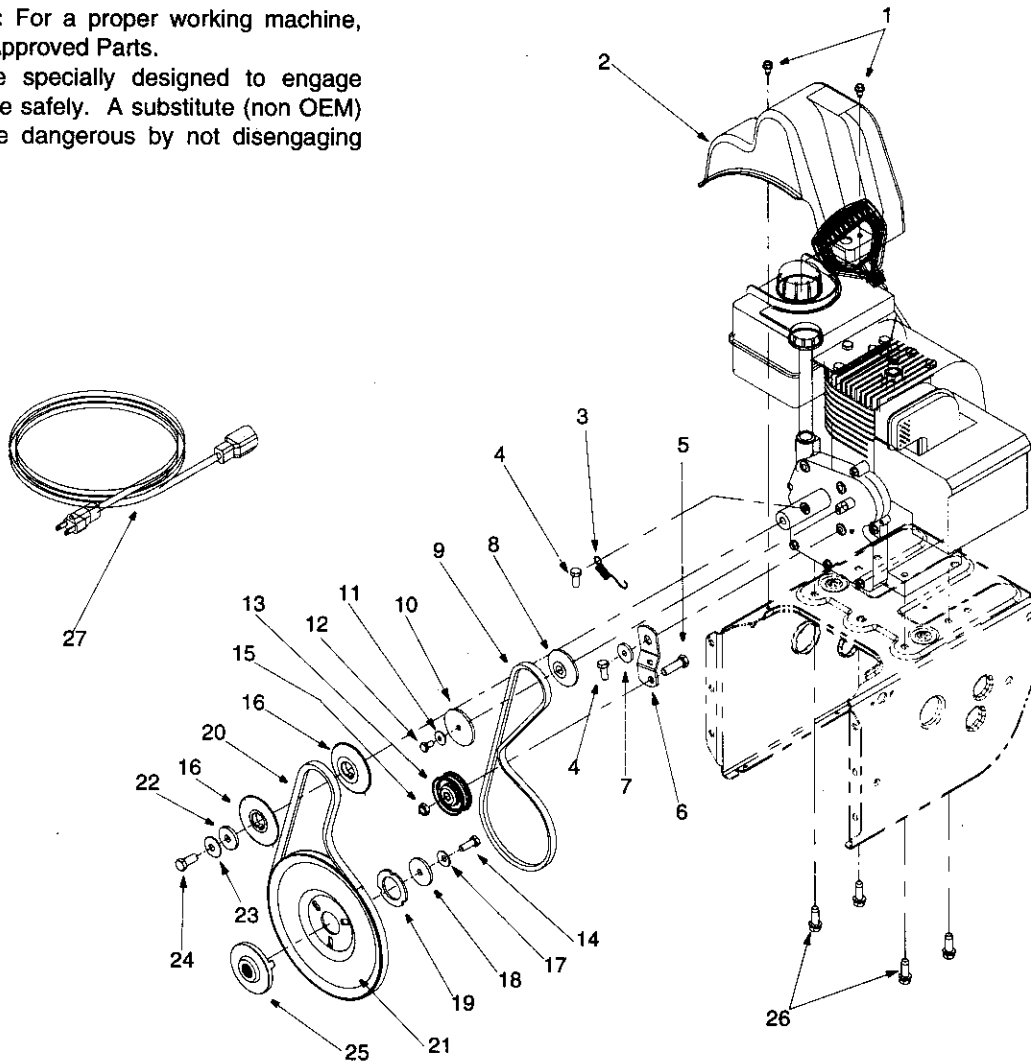

REF. NO.	PART NO.	DESCRIPTION	REF. NO.	PART NO.	DESCRIPTION
1	710-1652	Hex Washer Screw 1/4-20 x.625	15	712-0181	Lock Jam Nut 3/8-16
2	731-1324	Belt Cover	16	756-0569	Pulley Half
3	732-0339	Extension Spring	17	736-0242	Bell Washer
4	710-0627	Hex Screw 5/16-24 x .75	18	736-0505	Flat Washer
5	710-3005	Hex Cap Screw 3/8-16 x 1.25	19	736-0507	Washer
6	05896A	Drive Clutch Bracket	20	754-0430A	Belt
7	748-0234	Shoulder Spacer	21	756-0967	Auger Pulley
8	756-0985	Pulley Half	22	736-0247	Flat Washer
9	754-0343	V-Belt	23	736-0331	Bell Washer
10	756-0984	Pulley Half	24	710-0696	Hex Cap Screw 3/8-24
11	736-0270	Bell Washer	25	748-0360	Pulley
12	710-0230	Hex Cap Screw 1/4-28 x .50	26	710-0654A	Hex Washer Screw 3/8-16 x 1.0
13	756-0313	Flat Idler	27	629-0071	Extension Cord
14	710-1245	Lock Cap Screw 5/16-24		OEM-390-986	Electric Start Kit

# Blower Housing

## Model 611

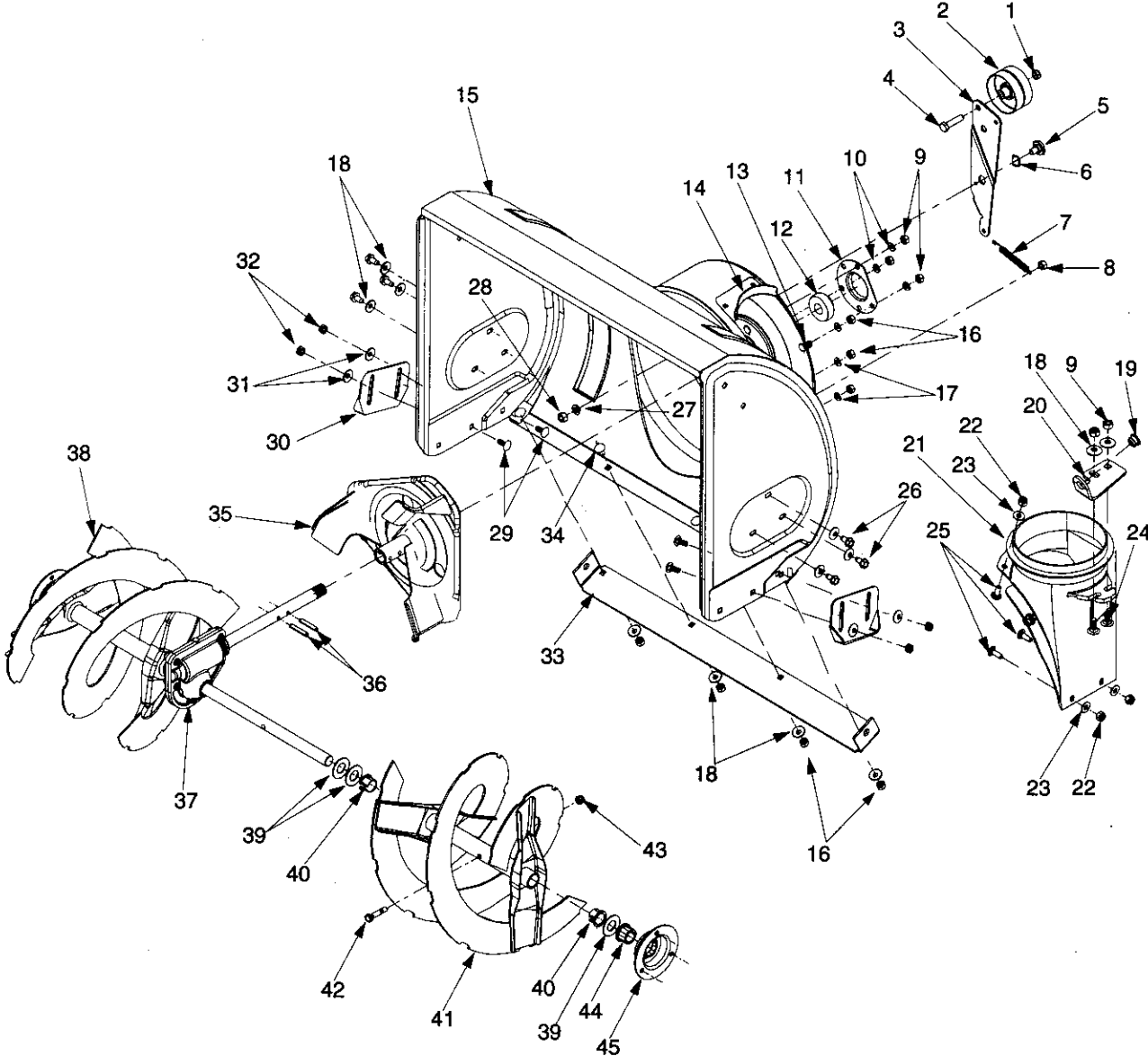

# Blower Housing

## Model 611

REF. NO.	PART NO.	DESCRIPTION	REF. NO.	PART NO.	DESCRIPTION
1	712-0116	Lock Jam Nut 3/8-24	25	710-0703	Carriage Screw 1/4-20 x .75
2	756-0178	Flat Idler	26	710-0604	Hex Washer Screw 5/16-18
3	784-5632A	Auger Idler Arm	27	736-0169	Lock Washer 3/8
4	710-0459A	Hex Cap Screw 3/8-24 x 1.50	28	712-0798	Hex Nut 3/8-16
5	738-0281	Shoulder Screw	29	710-0451	Carriage Bolt 5/16-18 x .75
6	736-0174	Wave Washer	30	784-5580	Snow Shoe
7	732-0611	Extension Spring	31	736-0242	Bell Washer
8	712-3068	Hex Nut 5/16-18	32	712-3010	Hex Nut 5/16-18
9	712-3010	Hex Nut 5/16-18	33	784-5576	22" Shave Plate
10	736-0119	Lock Washer 5/16		784-5581A	24" Shave Plate
11	05931	Housing	34	710-0451	Carriage Bolt 5/16-18 x .62
12	741-0309	Ball Bearing	35	684-0065	Impeller Assembly
13	710-0451	Carriage Bolt 5/16-18	36	715-0114	Pin
14	705-5226	Reinforcement Chute	37	618-0152	22" Gear Assembly
15	684-0052B	22" Housing Assembly		618-0120	24" Gear Assembly
	684-0039C	24" Housing Assembly	38	605-5252A	Spiral 22" RH
16	712-3010	Hex Nut 5/16-18		605-5188A	Spiral 24" RH
17	736-0119	Lock Washer 5/16	39	736-0188	Flat Washer
18	736-0242	Bell Washer	40	741-0493A	Flange Bushing
19	741-0475	Bushing	41	605-5253A	Spiral 22" LH
20	784-5647	Chute Directional Control Bracket		605-5189A	Spiral 24" LH
21	731-1379A	Chute Adapter	42	710-0890A	Shear Bolt 5/16-18 x 1.5
22	712-0324	Hex Lock Nut 1/4-20	43	712-0429	Lock Nut 5/16-18
23	736-0463	Flat Washer	44	741-0245	Hex Flange Bearing
24	710-0451	Carriage Bolt	45	784-5618	Bearing Housing

# Handle Assembly

## Model 611

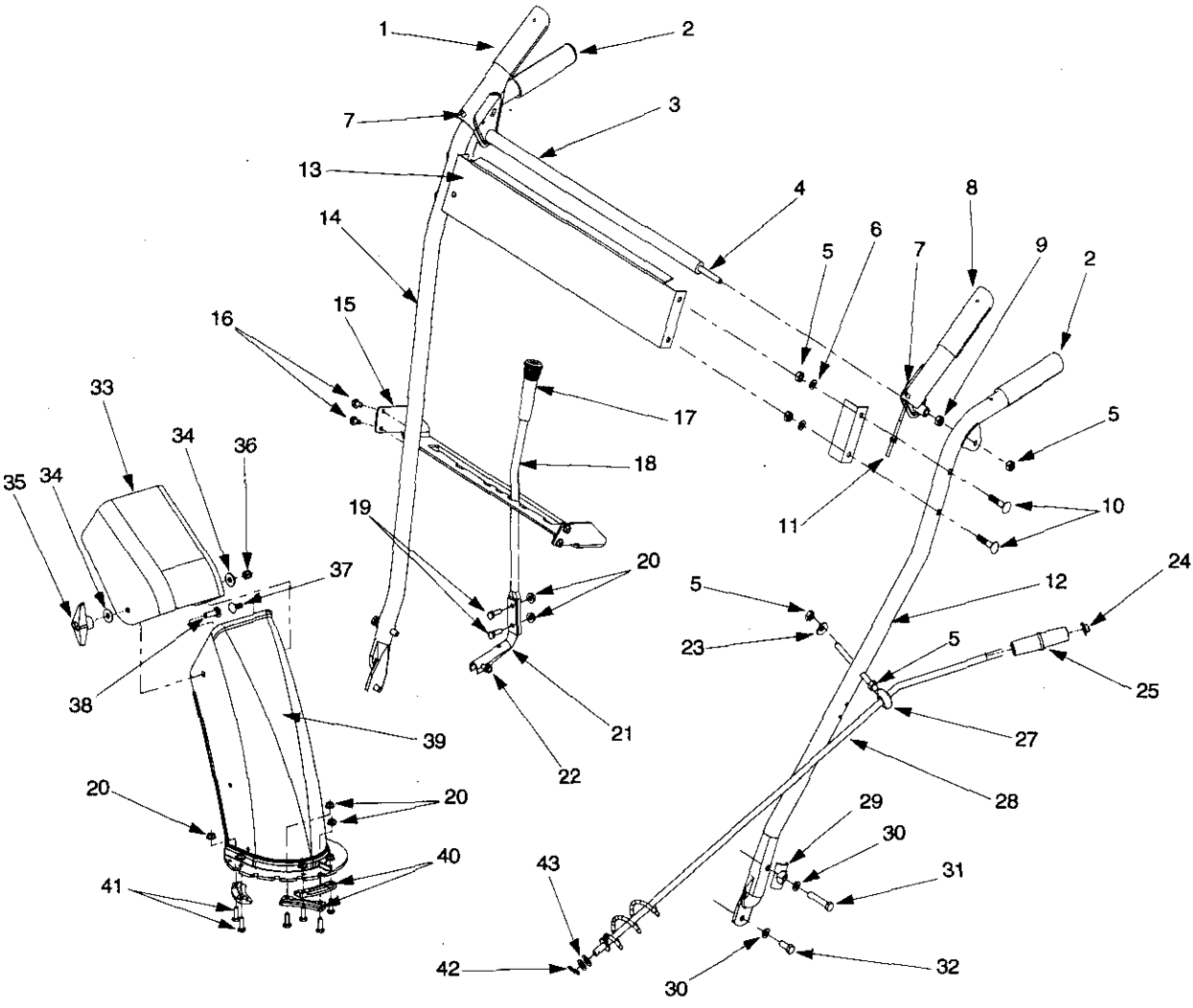



# Handle Assembly

## Model 611

REF. NO.	PART NO.	DESCRIPTION	REF. NO.	PART NO.	DESCRIPTION
1	705-5234	Clutch Lever Assy - RH	23	736-0242	Bell Washer
2	720-0204	Grip	24	726-0100	Push Cap
3	731-1500	Pivot Rod Cover	25	720-0201A	Chute Knob
4	747-0905	Pivot Rod	27	747-0697	Eyebolt
5	712-3010	Hex Nut 5/16-18	-	735-0234	Grommet only
6	736-0119	Lock Washer 5/16	28	705-5204A	Chute Directional Control Assembly
7	735-0199A	Rubber Bumper	29	784-5599	Handle Tab
8	705-5233	Clutch Lever Assy - LH	30	736-0119	Lock Washer 5/16
9	712-3027	Lock Hex Nut 1/4-20	31	710-3180	Hex Cap Screw 5/16-18 x 1.75
10	710-0262	Carriage Bolt 5/16-18 x 1.50	32	710-3008	Hex Cap Screw 5/16-18 x .75
11	746-0778	Z - Cable	33	731-0921	Upper Chute
12	684-0047A	Handle - LH	34	736-0159	Washer 5/16
13	705-5232	Panel	35	720-0284	Knob
14	684-0048A	Handle - RH	36	712-0429	Hex Lock Nut 5/16-18
15	705-5231	Speed Select Panel	37	710-0451	Carriage Bolt 5/16-18 x .75
16	710-0599	Hex Washer Screw 1/4-20 x .50	38	710-0276	Carriage Screw 5/16-18 x 1.0
17	720-0223	Grip	39	731-1300A	Lower Chute
18	747-0904	Shift Lever	40	731-0851A	Flange Keeper
19	710-3015	Hex Cap Screw 1/4-20 x .75	41	710-3015	Hex Cap Screw 1/4-20 x .75
20	712-3027	Hex Lock Nut 1/4-20	42	714-0104	Cotter Pin
21	732-0733	Shift Lever Spring	43	736-0185	Flat Washer 3/8
22	710-0788	Hex Washer Screw 1/4-20 x 1.0			

# Frame Assembly

## Model 611

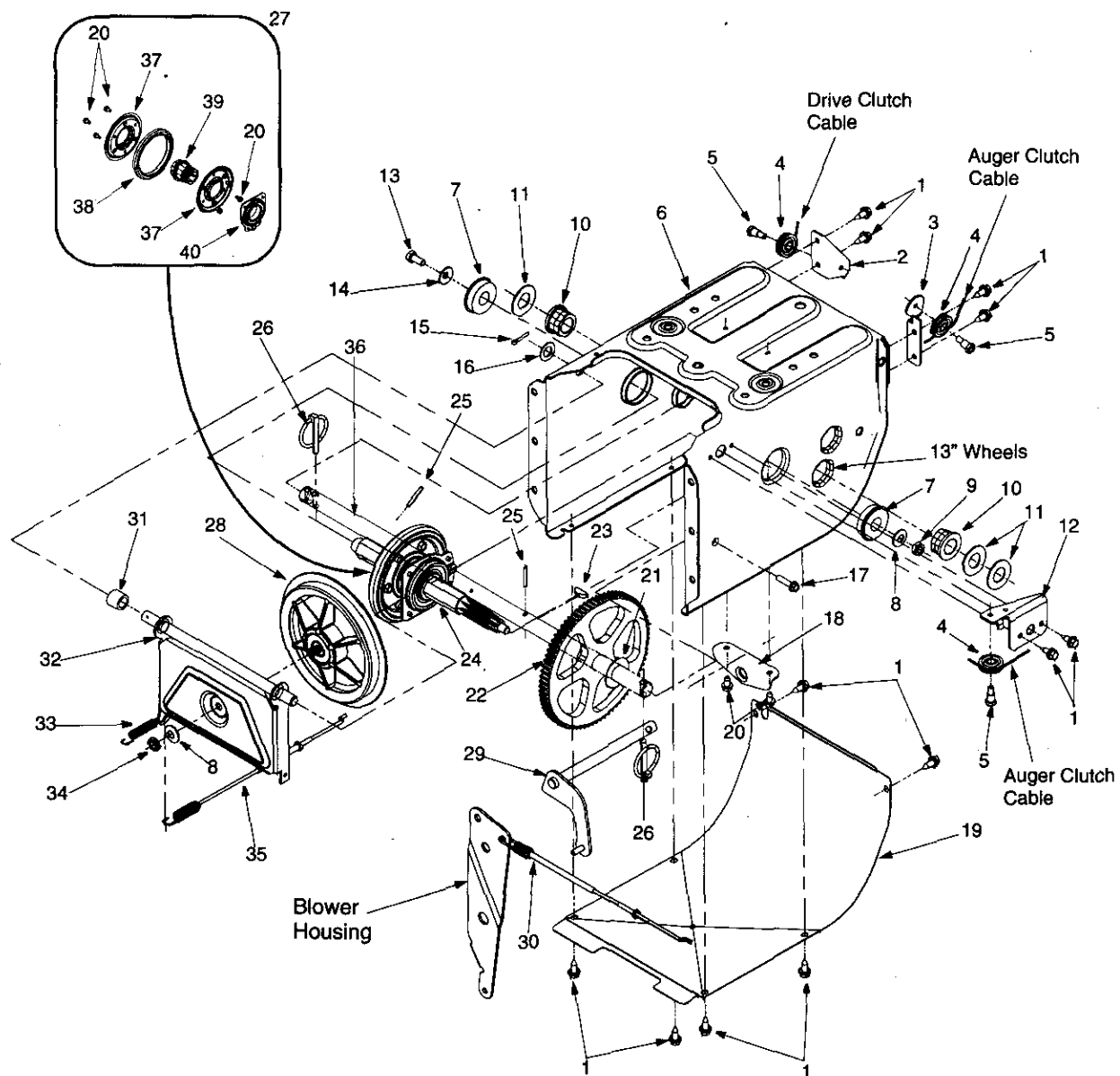

# Frame Assembly

## Model 611

REF. NO.	PART NO.	DESCRIPTION	REF. NO.	PART NO.	DESCRIPTION
1	710-1652	Hex Screw	22	717-1445	Gear
2	784-5688	Drive Cable Guide Bracket	23	714-0126	Key
3	784-5687A	Auger Clutch Cable Bracket	24	717-1444	7-Tooth Shaft
4	756-0625	Roller Cable	25	715-0249	Roll Pin
5	738-0924	Hex Screw 1/4-28	26	714-0143	Klik Pin
6	684-0030	Frame Assembly	27	684-0042B	Friction Wheel Assembly
7	741-0563	Ball Bearing	28	656-0012A	Friction Disc Wheel
8	736-0105	Bell Washer	29	684-0013B	Wheel Shift Rod Assembly
9	712-0116	Lock Jam Nut	30	746-0897	Drive Cable
10	741-0598	Hex Flange Bearing	31	748-0190	Spacer
11	736-0188	Flat Washer	32	684-0021	Friction Wheel Bracket Assembly
12	784-5689A	Front Support Guide Bracket	33	732-0264	Extension Spring
13	710-0538	Lock Hex Screw	34	712-0711	Jam Nut 3/8-24
14	736-0242	Bell Washer .340 ID x .872 OD	35	746-0898	Drive Cable
15	714-0474	Cotter Pin	36	738-0869	22 .2" Axle (used w/ 13 x 4 tire)
16	736-0160	Flat Washer .536 ID x .930 OD		738-0991	21.4" Axle (used w/ 13 x 5 tire)
17	710-0788	Hex Washer Screw 1/4-20	37	784-5617A	Friction Plate
18	784-5590	Frame Shift Bracket	38	735-0243	Friction Wheel Rubber
19	784-5638	Frame Cover	39	718-0301A	Friction Wheel Hub
20	710-0599	Hex Washer Screw 1/4-20	40	618-0063	Friction Wheel Bearing
21	736-0351	Flat Washer .760 ID x .50 OD			

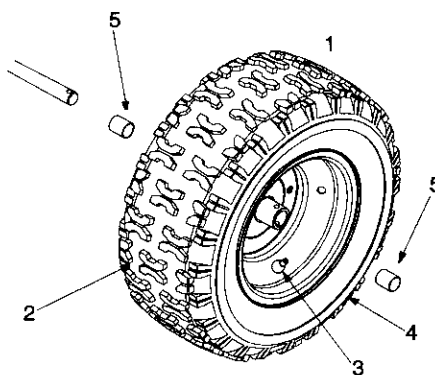

Wheel Assembly						
SIZE	REF. NO. 1 WHEEL ASS'Y COMPLETE	REF. NO. 2 TIRE ONLY	REF. NO. 3 AIR VALVE	REF. NO. 4 RIM ONLY	REF. NO. 5 SLEEVE BEARING (2)	REF. NO 6 Klik Pin
13 x 4	634-0114	734-1732	734-0255	734-1713	741-0401	714-0143
13 x 5 (Used w/22" Housing)	634-0166	734-1527	734-0255	684-0129	741-0401	714-0143
13 x 5 (Used w/24" Housing)	734-1714	734-1527	734-0255	734-1713	741-0401	714-0143

# MANUFACTURER'S LIMITED WARRANTY FOR:



The limited warranty set forth below is given by MTD PRODUCTS INC ("MTD") with respect to new merchandise purchased and used in the United States, its possessions and territories.

MTD warrants this product against defects in material and workmanship for a period of two (2) years commencing on the date of original purchase and will, at its option, repair or replace, free of charge, any part found to be defective in material or workmanship. This limited warranty shall only apply if this product has been operated and maintained in accordance with the Operator's Manual furnished with the product, and has not been subject to misuse, abuse, commercial use, neglect, accident, improper maintenance, alteration, vandalism, theft, fire, water or damage because of other peril or natural disaster. Damage resulting from the installation or use of any accessory or attachment not approved by MTD Products Inc. for use with the product(s) covered by this manual will void your warranty as to any resulting damages.

Normal wear parts or components thereof are subject to separate terms as follows: All normal wear part or component failures will be covered on the product for a period of 90 days regardless of cause. After 90 days, but within the two year period, normal wear part failures will be covered ONLY IF caused by defects in material or workmanship of OTHER component parts. Normal wear parts and components include, but are not limited to, belts, blades, blade adapters, grass bags, rider deck wheels, seats, snow thrower skid shoes, shave plates and tires. Batteries are covered by a 90-day limited replacement warranty.

**HOW TO OBTAIN SERVICE:** Warranty service is available, WITH PROOF OF PURCHASE THROUGH YOUR LOCAL AUTHORIZED SERVICE DEALER. To locate the dealer in your area, please check for a listing in the Yellow Pages or contact the Customer Service Department of MTD PRODUCTS INC by calling 1-800-800-7310 or writing to P.O. Box 368022, Cleveland, Ohio 44136-9722. No product returned directly to the factory will be accepted unless prior written permission has been extended by the Customer Service Department of MTD PRODUCTS INC.

**This limited warranty does not provide coverage in the following cases:**

- a. The engine or component parts thereof. These items carry a separate manufacturer's warranty. Please refer to the applicable manufacturer's warranty on these items.
- b. Routine maintenance items such as lubricants, filters, blade sharpening and tune-ups, or adjustments such as brake adjustments, clutch adjustments or deck adjustments; and normal deterioration of the exterior finish due to use or exposure.
- c. Log splitter pumps, valves and cylinders have a separate one year warranty.
- d. MTD does not extend any warranty for products sold or exported outside of the United States of America, its possessions and territories, except those sold through MTD's authorized channels of export distribution.

**No implied warranty, including any implied warranty of merchantability or fitness for a particular purpose, applies after the applicable period of express written warranty above as to the parts as identified. No other express warranty or guaranty, whether written or oral, except as mentioned above, given by any person or entity, including a dealer or retailer, with respect to any product shall bind MTD. During the period of the Warranty, the exclusive remedy is repair or replacement of the product as set forth above. (Some states do not allow limitations on how long an implied warranty lasts, so the above limitation may not apply to you.)**

**The provisions as set forth in this Warranty provide the sole and exclusive remedy arising from the sales. MTD shall not be liable for incidental or consequential loss or damages including, without limitation, expenses incurred for substitute or replacement lawn care services, for transportation or for related expenses, or for rental expenses to temporarily replace a warranted product. (Some states do not allow the exclusion or limitation of incidental or consequential damages, so the above exclusion or limitation may not apply to you.)**

In no event shall recovery of any kind be greater than the amount of the purchase price of the product sold. Alteration of the safety features of the product shall void this Warranty. You assume the risk and liability for loss, damage, or injury to you and your property and/or to others and their property arising out of the use or misuse or inability to use the product.

This limited warranty shall not extend to anyone other than the original purchaser, original lessee or the person for whom it was purchased as a gift.

**How State Law Relates to this Warranty:** This limited warranty gives you specific legal rights, and you may also have other rights which vary from state to state.