

Operator's Manual

**CRAFTSMAN®**

**PROFESSIONAL**

4.1 HP/2-Cycle  
51 cc./3.15 cu. in.

## CHAIN SAW

Model No. 360.352001 – 20-inch Bar

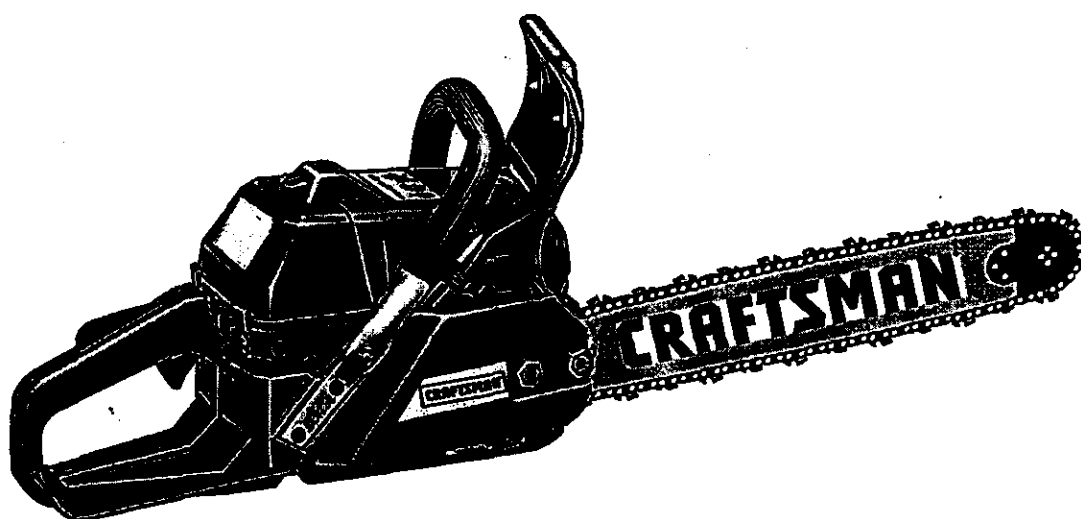

### CAUTION:

Before using this product, read this manual and follow all its Safety Rules and Operating Instructions.

- Safety
- Operation
- Maintenance
- Service & Adjustments
- Parts
- Español

Sears, Roebuck and Co., Hoffman Estates, IL 60179 U.S.A.  
Visit our Craftsman website: [www.sears.com/craftsman](http://www.sears.com/craftsman)

## SAFETY INSTRUCTIONS

**CAUTION:** Always disconnect spark plug wire and place where it cannot contact spark plug to prevent accidental starting when setting up, transporting, adjusting or making repairs.

### TRAINING

Read the operator's manual carefully prior to operation. Become familiar with the controls and know how to operate your chain saw properly.

- Keep the area of operation clear of all persons, especially small children and pets.
- Use the chain saw only as described in this manual.
- Do not allow children to operate your chain saw. Never allow adults to use the chain saw without proper instructions.
- Do not operate the chain saw if it has been dropped or damaged in any manner. Always have damage repaired before using your chain saw.
- Use only recommended Craftsman accessories and replacement parts. Use of non-Craftsman parts and accessories may be hazardous.

### PREPARATION

- Always wear safety glasses or eye shields when starting and while using your chain saw.
- Dress properly. Do not operate chain saw when barefoot or wearing open sandals. Wear only solid shoes with good traction.
- Wear long-sleeved clothes that are snug fitting. Avoid wearing loose clothing.
- Wear either tightly cuffed or cuffless pants.
- Wear hearing protection even when working for a short period of time. Remember - hearing damage is cumulative.
- Wear protective, non-slip gloves for safer operation.
- Always wear a "hard hat" in the working area. Overhead hazards such as falling limbs present danger of injury.
- Always wear safety boots with steel toes.
- Check fuel tank before starting engine. Do not fill fuel tank indoors, when the engine is running or when the engine is hot. Allow the engine to cool for several minutes before filling the fuel tank. Clean off any spilled gasoline before starting the engine.
- Always make adjustments before starting your chain saw. Never attempt to make adjustments while the engine is running.
- Use only in daylight or good artificial light.

### OPERATION

- Keep your eyes and mind on your chain saw. Do not let yourself be distracted.
- Always be sure of your footing. Use extra caution in wet or slippery grass. WALK – DON'T RUN.
- Do not put hands or feet near rotating parts. Keep clear of chain at all times.
- Always stop the engine whenever you leave or are not using your chain saw.
- Before cleaning, inspecting, or repairing your chain saw, stop the engine and make absolutely sure all moving parts have stopped. Then disconnect spark plug wire and keep it away from the spark plug to prevent accidental starting.
- Do not adjust carburetor. Overspeeding engine may result in engine damage or personal injury.
- Do not run the engine indoors. Exhaust fumes are dangerous.
- Never operate your chain saw without proper guards or other safety devices in place.
- Never remove hands from chain saw handles when actively cutting with the saw.

### WARNING: California Proposition 65

The engine exhaust from this product contains chemicals known to the State of California to cause cancer, birth defects, or other reproductive harm.

### KICKBACK CONDITIONS AND PREVENTION

Kickback occurs when the upper quadrant of the bar nose contacts a solid object in the wood or is pinched. This type of contact stops the chain for an instant. The result is a lightning fast reverse reaction of the chain; causing the bar to "kick" up and back toward the operator. Under some circumstances the operator (Fig. 1) may suffer severe or fatal injury. Kickback may also occur during limbing (See LIMBING).

FIGURE 1

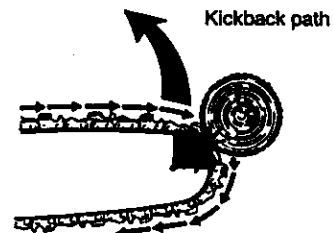

## TO AVOID KICKBACK

The best protection from personal injury that may result from Kickback is to avoid Kickback situations.

- Hold the chain saw firmly with both hands and maintain a secure grip.
- Be aware of the location of the guide bar nose at all times (Fig. 2).

FIGURE 2

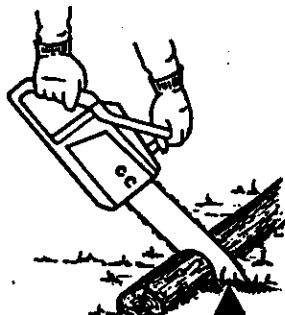

Do not let the bar contact the ground

- Never bring the nose of the guide bar in contact with any object. Do not cut limbs with the nose of the guide bar. Be especially careful with small, tough limbs, small-size brush, and saplings which may easily catch the chain.
- Don't overreach.
- Don't cut above shoulder height. Do not use a chain saw while standing on a tree or ladder!
- Begin and continue cutting at full throttle.
- Cut only one lot at a time.
- Use extreme caution when re-entering a previous cut.
- Do not attempt plunge cuts if you are not familiar with these cutting techniques.
- Be alert of shifting log or other forces that may cause the cut to close and pinch the chain.
- Maintain saw chain properly. Cut with a correctly sharpened, properly tensioned chain at all times (Use a 4.5-mm file).
- Stand to the side of cutting path of the chain saw.
- If the cut closes on the bar, STOP the saw. Use a wedge to free the saw. Do not try to free it by pulling the handle.

**WARNING:** A dull or improperly sharpened chain may increase the risk of Kickback. Always cut with a properly sharpened saw. Improper lowering of the depth gauges also increases the chance of kickback.

## ABOUT THE CHAIN BRAKE

The main components of the chain brake assembly are the lever-handguard and a brake band around the clutch drum. The brake is automatically engaged when kickback occurs. When engaged, the brake band clamps down around the clutch drum, stopping both the drum and the chain in less than 1/10 of one

second. The chain brake can also be engaged manually by pushing the lever-handguard towards the front of the saw until a loud click is heard. The saw should not be run above idle for more than a few seconds with the brake engaged; otherwise damage to the saw will occur.

To properly disengage the chain brake; firmly pull the lever-hand guard back towards the handle (Fig. 3) until a loud click is heard. Failure to completely disengage the brake properly will cause excessive heat build-up on the brake band which, in turn, can cause severe damage to the saw body.

FIGURE 3

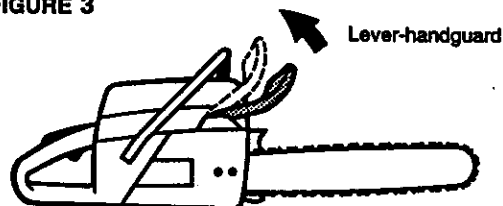

## CUSTOMER RESPONSIBILITIES

- Read and observe the safety rules.
- Follow a regular schedule in maintaining, caring and using your chain saw.
- Follow the instructions under the Maintenance and Storage sections of this manual.

**SPECIAL NOTICE:** For users on U.S. Forest Land and in some states, including California (Public Resources Code 4442 and 4443), Idaho, Maine, Minnesota, New Jersey, Oregon and Washington: Certain internal combustion engines operated on forest, brush, and/or grass-covered land in the above areas are required to be equipped with a spark arrestor, maintained for the prevention of fire. Check with your state or local authorities for regulations pertaining to these requirements. Failure to follow these requirements is a violation of the law. This unit is not factory-equipped with a spark arrestor; however, a spark arrestor is available as an optional part. If a spark arrestor is required in your area, contact your Authorized Service Center for the correct kit.

## ASSEMBLY

Your new chain saw has been assembled at the factory. No further assembly is necessary.

## CONTENTS OF CARTON

- Chain Saw
- Combi-Wrench

Read these instructions and the operating manual in its entirety before you attempt to operate your new chain saw.

## ACCESSORIES

The following items for the operation of your chain saw are available at your nearest Sears store.

- Safety goggles
- Hearing protection
- Gloves
- 2-Cycle air cooled engine oil
- Air filter
- Fuel Stabilizer
- Spark plug
- Gas can

## OPERATION

### KNOW YOUR CHAIN SAW

Read this Operator's Manual and Safety Instructions before operating your chain saw. Compare the illustration below (Figure 4) with your chain saw to familiarize yourself with the location of various controls and adjustments. Save this manual for future reference.

1. Spark Plug
2. Air Filter
3. Primer
4. Choke Lever
5. On-Off Switch
6. Safety Lever
7. Throttle Lever
8. Fuel-Oil Mix Cap
9. Cover Over Pre-Filter
10. Bar-Chain Oil Cap
11. Bar
12. Chain
13. Bar Nuts
14. Half Throttle Pin (Pg. 6)
15. Side Cover
16. Top Cover
17. Lever – Handguard (Pg. 4)
18. Bucking Spike
19. Chain Tensioning Screw
20. Chain Tensioning Lug
21. Clutch Drum
22. Chain Brake Band
23. Oil Adjustment Screw
24. Sprocket
25. Serial Number

FIGURE 4

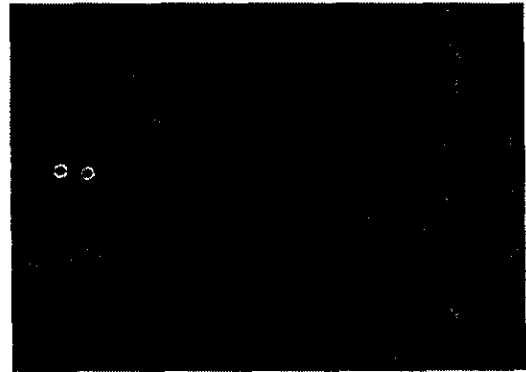
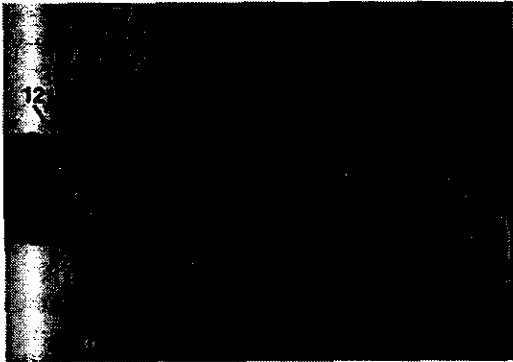

## HOW TO USE YOUR CHAIN SAW

### GASOLINE AND OIL MIXTURE

**Important!** Do not use automotive or boat oils in your chain saw. These oils do not have proper additives for 2-cycle, air-cooled engines and can cause engine damage.

The 2-cycle engine on this product requires a fuel mixture of regular unleaded gasoline and a high quality 2-cycle air-cooled engine oil for lubrication of the

bearings and other moving parts. The correct fuel-oil mixture is 40:1 (see Fuel Mixture Chart). Too little oil or the incorrect oil type will cause poor performance and may cause the engine to overheat and seize.

Gasoline and oil must be premixed in a clean approved fuel container. Always use fresh regular unleaded gasoline. This engine is certified to operate on unleaded gasoline.

#### FUEL MIXTURE CHART

GASOLINE	OIL
1 Gallon	3.2 Ounces
2.5 Gallons	8.0 Ounces

**IMPORTANT!** Alcohol blended fuels called gasohol (using ethanol or methanol) can attract moisture, which leads to fuel - oil separation and formation of acids during storage. Acidic gas can damage the fuel system of an engine while in storage. To avoid engine problems, the fuel system should be emptied before storage of 30 days or longer. Drain the gas tank, then run the fuel out of the carburetor and fuel lines by starting the engine and letting it run until it stops. Use fresh fuel next season. See storage instructions for additional information. Never use engine or carburetor cleaner products in the fuel tank or permanent damage may occur.

#### 2-CYCLE OIL

Craftsman 2-cycle, air-cooled engine oil is specially blended with fuel stabilizers. If you do not use this Sears oil, you can add a fuel stabilizer, such as Craftsman No. 33500, to your fuel mix.

#### FUEL STABILIZER

A fuel stabilizer is an acceptable alternative in minimizing the formation of fuel gum deposits during storage. Add stabilizer to gasoline mixture in fuel storage container and mix well. Always follow the fuel mix ratio found on the stabilizer container. Run engine at least 5 minutes after adding stabilizer to allow the stabilizer to reach the carburetor. You do not have to drain the fuel tank for storage if you are using fuel stabilizer.

#### BAR AND CHAIN OIL

We recommend a special chain oil (low sling, high tack) to lubricate your bar and chain; consult your local Sears retailer. During chain saw operations at temperatures below freezing (0°C/32°F), the chain oil viscosity increases creating an overload to the automatic oil pump. Overloading results in damage to the driver gear, pump mechanism, and bar and chain. A special cold-climate chain oil should be used. Refill chain oil each time you refuel. **CAUTION:** Never use waste engine oil; it will damage the pump.

#### OIL PUMP

Your chain saw is equipped with an automatic oil pump that pumps oil to the chain when the chain is rotating. You may adjust the amount of oil pumped to compensate for long bars and chains or for extremely hard or frozen wood. Adjust the flow rate by turning the adjustment screw. The adjustment screw is located on the bottom of the saw below the markings + - on the same side as the bar and chain (Fig. 5). Turning

counterclockwise (+) increases the amount of oil, clockwise (-) decreases the flow. Never cut without chain lubrication. Check proper level before each cutting.

FIGURE 5

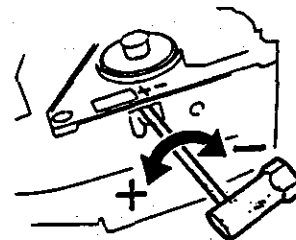

#### STOPPING ENGINE

To stop engine, release the throttle lever. Move the On-Off switch to the off (STOP) position.

#### STARTING COLD

**NOTE: Check chain tension before starting!**

1. Turn the on-off switch to the on "I" position.
2. Pull out the choke knob. The fast idle stays set until the throttle is depressed, at which time the red pin inside the choke lever retracts (idle position).

**CAUTION:** Retain a secure grip on the saw using the foot and hand position for starting the chain saw in a safe manner.

3. Pump fuel primer until it is approximately ½ full with fuel and increased resistance is felt. Proceed with cold starting instructions.
4. Slowly pull on starter grip until rope encounters some resistance from starter pulley. Next, pull rope firmly and rapidly in an upward motion. Guide rope back into starter rather than letting it snap back.
5. Repeat rope pulls until engine attempts to start, usually 2-3 pulls, no more than 5; then immediately push in choke knob.
6. Once the engine is steadily running depress and release the throttle lever to allow engine to operate at idle speed. **NOTE:** Depressing (and then releasing) the throttle lever releases the half-throttle automatic lock and the red indicator pin on the choke knob retracts. The engine continues to run at idle speed.
7. Should the engine fail to start after several repeated starting attempts, the engine has already been "flooded" (too much fuel mixture in cylinder). In this case, remove the spark plug and dry it. Set the ignition switch to "stop" and the throttle lever to full throttle. Crank engine by pulling the starter rope several times to vent fuel mix and vapors from cylinder and crankcase. Check spark plug gap (.015-.020"); correct if necessary. Reinstall spark plug; connect spark plug cap. Set ignition

## STARTING WARM

1. Pull choke knob out.
2. Push choke knob back into open position, red indicator pin on choke button remains visible.
3. Crank engine and allow to run briefly.
4. Depress throttle lever to allow engine to run at idle speed (indicator pin disappears).

If you are unsuccessful in starting the engine, consult the Troubleshooting guide in your Craftsman chain saw handbook or contact a Sears Service Center.

## SAFE FELLING AND CUTTING TECHNIQUES

Before felling a tree, survey it carefully and answer these questions:

1. In which direction does the tree lean?
2. Is the condition of the trunk sound, hollow or partially rotten?
3. From which direction is the wind blowing?
4. What is the wind velocity? **CAUTION:** Wind direction and velocity may change. Be alert! Felling should not be attempted in high winds.
5. Is the crown (top) of the tree more dense and heavier on one side?

These are factors and forces which will influence the line of fall and escape routes.

Survey the area; make sure that felled trees cannot strike any objects such as power lines, buildings, cars and block roadways or railroad tracks. Insure that neither persons nor animals are within the danger zone (measured distance away from tree that is  $2\frac{1}{2}$  times the tree height).

**NOTE:** These basic rules apply to felling a single tree or many. However, and additional organizing is required when felling several trees. Preliminary preparation must be done outside the danger zone. Be sure others know where you are and what you are doing at all times.

**CAUTION:** Do not try to fell a tree along a line different from its natural line of fall unless you have considerable experience.

Determine carefully the correct line of fall. Clear two safe exit paths to the rear (clear away escape routes for each member of the felling team). Do not place tools and equipment in the path. Make your escape route at a  $45^\circ$  angle back and away from the line of fall (Fig. 6).

FIGURE 6

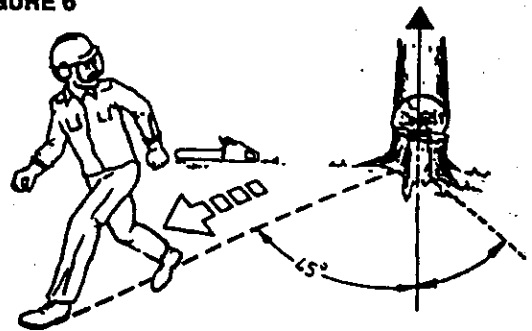

Clear escape route by removing undergrowth likely to interfere with escape. Be sure to warn others by shouting "TIMBER" when a tree is about to fall. Brief each team member on proper escape procedures and signals. Have visual contact with team members prior to and during felling operation. Practice a "dry run" escape! Prior to felling prepare the immediate site and the base of the tree by clearing away undergrowth with an axe, not the saw. Undergrowth can tangle up or snag the saw chain resulting in serious injury or saw damage. Clean the trunk of brush and remove small branches from the lower trunk with a small axe.

Remove large buttress roots first. Start by cutting the largest buttress root. Remove each by cutting it vertically first, then horizontally (Fig. 7). Small buttress roots can be removed when felling is complete unless they hamper the felling process.

FIGURE 7

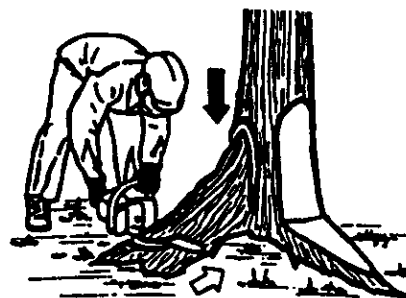

When felling, assume a balanced body position (Fig. 8). Position the feet parallel and apart to obtain a steady stance and stand at the side of the tree. Lower the point of gravity by bending the knees (comfortably arch your back). Keep the saw near the body, hold it firmly with both hands, and lock the thumbs under the handlebar at all times.

FIGURE 8



**CUTTING FELLING NOTCH**

Start felling by making a careful felling notch (undercut) first (Fig. 9). This notch determines the line of fall. Position it at a right angle. Cut the felling notch to a depth of about 1/4 of the trunk diameter. It must be wide enough and should never be higher than its depth.

FIGURE 9



To make the felling notch, start with the upper cut facing the line of fall. This is a directional cut downwards at an angle (Fig. 10, 1). Next, make the lower felling notch cut. Cut horizontally and straight into the tree until it meets the upper cut forming a wedge (Fig. 10, 2).

FIGURE 10

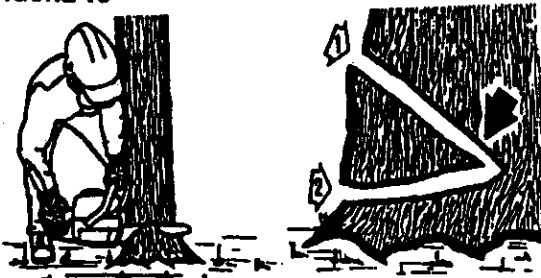

The exception is when the tree is on a slope; then the lower cut should be on an upward angle to cut a larger, more open wedge and to gain greater control during the fall of the tree (Fig. 11).

FIGURE 11

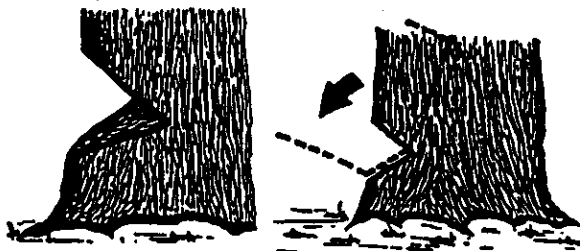

**CAUTION:** Maintain good footing, body balance and insure a safe escape path has been established. Never fell a tree without making a proper felling notch (undercut).

The next cut (Fig. 11) is called the felling cut (back cut). Make it at least 2" higher than the lower cut of the felling notch by cutting horizontally and parallel to the felling notch. Do not cut through to the felling notch. Leave a "hinge" of uncut wood approximately 1/10 of the tree diameter (Fig. 11).

**WARNING:** To avoid personal injury, do not cut through the hinge! A proper hinge prevents the tree from possibly "sitting back" or "butt kicking" the back of the stump, twisting off the stump, or falling prematurely and uncontrolled.

When felling a large tree, drive wedges into the felling cut. Use only wooden or plastic wedges. Never use steel or iron wedges which can cause kickback and damage to the chain. Wedges prevent the tree from settling back on the bar and help control the direction of the fall toward the felling notch (fig. 12).

FIGURE 12



**SMALL TREES**

If the trunk diameter is smaller than the guide bar cutting length, be careful making the felling cut and forming the hinge. Once the felling cut has been made, place the bucking spike at the base line right behind the hinge, and do a fan cut (Fig. 13).

FIGURE 13

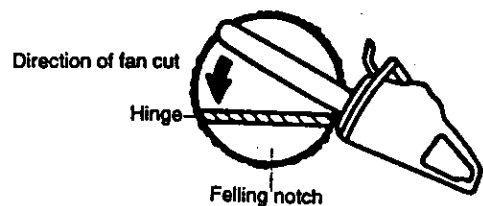

The bucking spike is the toothed metal piece attached to the front of the saw body and found to the left of the bar. With the bucking spike teeth against the log firm contact between the saw body and the log are maintained. A fan cut is accomplished by first contacting the teeth of the bucking spike to the log and then, using the bucking spike as the pivot point, rotating the bar through the log in a counterclockwise direction.

## LIMBING (Removing limbs from felled trees)

**WARNING:** Of all the cutting operations, limbing is the one that holds the most chance of unforeseen injury. The danger of kickback is most prevalent during limbing if the bar nose comes in contact with another branch or the side of the tree (see "Kickback Conditions and Prevention").

Professional loggers have developed various safe, efficient and effective limbing techniques which you must follow. The following instructions are a few of the basic safe work habits for a chain saw operator while limbing or removing branches from a tree.

1. Before starting to limb, be sure the branch is on a safe side of the log, uphill, and on the side opposite of any potential motion the cut branch might make (Fig. 14).

FIGURE 14



2. Do not stand on a log while limbing. You may slip, fall or the log may roll. Maintain sure footing.
3. Never use the bar nose to cut branches.
4. Bend the knees slightly. Position the right leg behind the left side of the chain saw and the left leg forward and outward away from contact range of bar. Assume a comfortable stance with the feet spread apart. **CAUTION:** If you change position, the bar must always be on the side of the tree opposite you. Keep the tree trunk between you and the bar.
5. Rest the chain saw body on the trunk as much as possible (Fig. 15).

FIGURE 15



6. Craftsman saws are designed to allow the powerhead to glide over the trunk during limbing. Cut the branches in a swinging back and forth movement with the saw remaining on the tree. This is known as the "pendulum method."
7. Prior to cutting the branches, consider the direction in which the branches may fall. This will determine whether you cut from the top down (overbuck, Fig. 16) or from below up (underbuck, Fig. 17).
8. Watch out for branches under tension which can snap back. Tension must be removed before these branches can be safely cut. Beware of potential kickback situations.
9. If large branches are to be used for firewood, cut them to length while still attached to the tree. This is an easier and safer method than bucking branches on the ground (Fig. 16 & 17).
10. If you tire during limbing, STOP! Rest, then resume work.
11. Never change the position of the feet or hands while in the midst of a cut.

FIGURE 16  
Overbucking



FIGURE 17  
Underbucking





### BUCKING (The cutting of a log into sections):

1. Be alert to the stress and motion of logs. Always position yourself to prevent the rolling of a cut log section or the stress forces within a log from acting against you.
2. Never stand directly behind the chain saw when cutting. Stand to the left side of the cutting path of the chain saw to reduce the chances of injury from kickback or a broken chain shooting backwards towards you (Fig. 18, 1).
3. Bend the knees slightly. Assume a comfortable stance with the feet spread apart (Fig. 18, 2).
4. Keep the left elbow straight while cutting (Fig. 18, 3).
5. Lock the thumb under the handlebar (Fig. 18, 4).

FIGURE 18

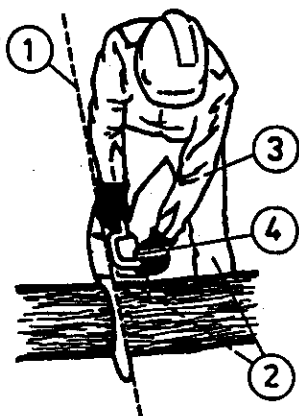

6. Set the bucking spikes firmly against the log.
7. When cutting firewood, place the log on a suitable support such as a saw buck (Fig. 19).

FIGURE 19



8. Free hanging ends can be cut off without risk of bar pinching. But if the wood is not to split or tear, make an undercut (underbucking, Fig. 20, 1) of about 1/3 the depth of the log diameter, then apply the finishing cut (overbucking, Fig. 20, 2).

FIGURE 20

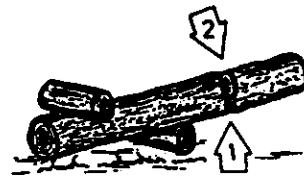

**WARNING:** Logs and branches may be under stress or tension. Before cutting check to see if stress exists. If stress does exist, start to cut on the right side of the log or branch to prevent pinching and possible kickback situations so that the branch does not whip back and strike you.

9. If the chain bar is pinched while bucking, shut off the engine immediately.

**IMPORTANT!** If the bar and chain become pinched, do not try to wrench or twist the bar free. Move the log into another position or lift up with a rod or lever (Fig. 21).

FIGURE 21

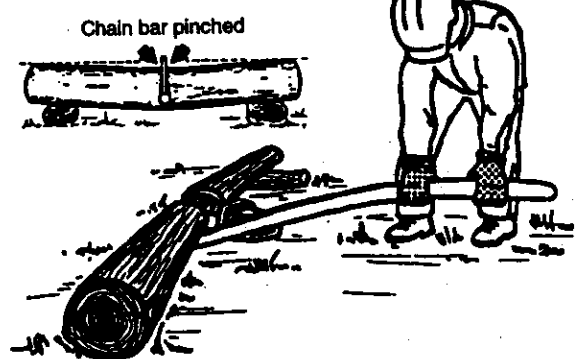

## MAINTENANCE

### GENERAL RECOMMENDATIONS

The warranty on this chain saw does not cover items that have been subjected to operator abuse or negligence. To receive full value from the warranty, operator must maintain chain saw as instructed in this manual.

All items in the Maintenance section of this manual should be checked at least once each season.

1. Service more often when operating in dusty or dirty conditions.
2. Once a year you should replace the spark plug and clean or replace the air filter. A new spark plug and a clean air filter assure proper air-fuel mixture and help your engine run better and last longer.

## MAINTENANCE SCHEDULE

FIGURE 22

	Frequency				
	Before Each Use	After Re-fueling	Daily	Monthly	As Required
Check for loose fasteners & parts	X				
Check for damaged or worn parts	X				
Check chain tension	X				
Check chain sharpness	X				
Refill bar and chain oil		X			
Inspect bar	X				
Clean engine cooling fins			X		
Clean air filter & pre-filter			X		
Replace spark plug					X
Clean fuel filter				X	
Inspect muffler				X	
Clean spark arrestor				X	

### CHECK FOR LOOSE FASTENERS & PARTS

Check all fasteners, including nuts, bolts, screws and clamps, to insure that they are tight and secure. If not, make all necessary adjustments prior to using chain saw.

### CHECK FOR DAMAGED OR WORN PARTS

Replacement of damaged or worn parts should be referred to your Sears Service Center

- On-Off Switch – Check function of the switch by running the saw then turning the switch to the "off" position. The engine should stop; then turn to the "on" position and restart.
- Fuel Tank & Oil Tank – Do not use the saw if oil or fuel leaks from the unit. **NOTE:** It is normal for a small amount of oil to drip from the bar and the side where the chain adjustment pin is located.

### CHECK CHAIN TENSION

If the chain is too loose it can come off the bar and possibly cause injury. **DO NOT** operate the saw if the chain is loose. To set your chain to the proper tension refer to Chain Tension in the Service and Adjustment section.

### CHECK CHAIN SHARPNESS

A sharp chain makes wood chips. A dull chain makes a sawdust powder and cuts slowly. Chain sharpening requires special tools. You can purchase sharpening tools at Sears or go to a professional chain sharpener.

### REFILL BAR AND CHAIN OIL

Your saw will use approximately one tank of bar oil for every tank of fuel mix. Always fill bar oil tank when you fill the fuel tank. For maximum bar and chain life, we recommend you use Craftsman chain saw bar oil. If Craftsman bar oil is not available, you may use a high quality bar and chain oil. **CAUTION:** Only use bar and chain oil; do not use motor oil. Motor oil will damage the saw.

### INSPECT BAR

Keep bar rails square and flat. Check for inside groove wear as follows. Place a straight edge (Fig. 23, A) against side of bar and one cutter. If there is clearance (Fig. 23, B) between bar and straight edge, the bar rails are good. If the chain leans (Fig. 24) and there is no clearance between bar and straight edge (Fig. 24, B), the bar rails are worn. Straightening worn bars, under certain circumstances, can only be done by service technicians. Replace bar if un-repairable. **IMPORTANT:** To prevent one-sided wear of the bar, flip the bar over after each chain sharpening.

FIGURE 23

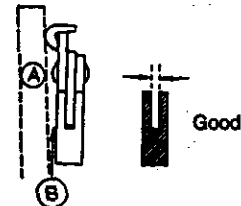
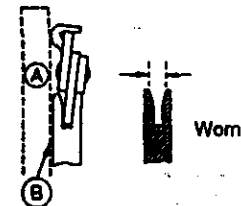
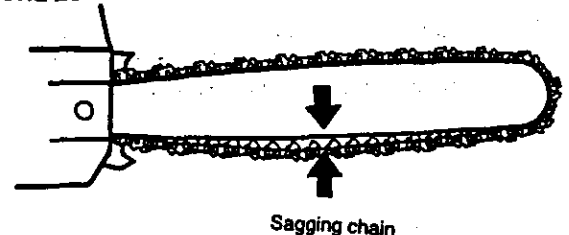

FIGURE 24



**WARNING:** Be sure chain is properly tensioned. A sagging chain (Fig. 25) can jump out of the bar groove and even break.

FIGURE 25



Clean the oil inlet hole (Fig. 26, A) and the bar groove prior to placing the chain in the bar groove.

FIGURE 26

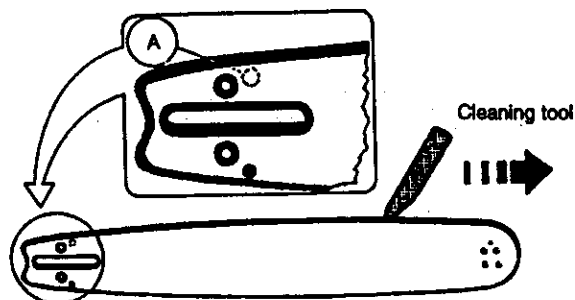

With sprocket nose bars (Fig. 27), grease the bearings of the sprocket with a grease gun containing bearing grease. Pump the grease into the cleaned out holes while rotating the sprocket. **WARNING:** Wear gloves when handling chain to prevent injury.

FIGURE 27

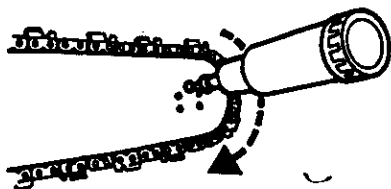

**IMPORTANT!** The bar is designed specifically to be a track for the chain. *Never* use bar to pry, lift or twist.

#### CLEAN ENGINE COOLING FINS

For best performance, keep dirt from accumulating around the engine cooling fins. Clogged cooling fins cause the engine to run hotter and shorten engine life. Cooling fins may be cleaned using a toothbrush or stiff bristle brush.

#### CLEAN AIR FILTER & PRE-FILTER

Your engine will not run properly and may be damaged by using a dirty air filter and/or pre-filter. Replace if deterioration occurs. Service more often if you use your chain saw in very dusty or dirty conditions.

##### To Clean Air Filter & Pre-Filter:

1. Remove air filter cover.
2. Remove pre-filter and air filter (Fig. 28). To remove air filter, slide retaining clip off and pull up on air filter.
3. Clean air filter with soft brush or tap lightly. If heavily soiled, rinse in a mild soap and water solution. The pre-filter must be blown clean with compressed air.
4. Dry air filter completely. Reassemble the pre-filter and air filter; ensure that they are correctly seated before reinstalling.
5. Replace filters if deteriorating.

FIGURE 28

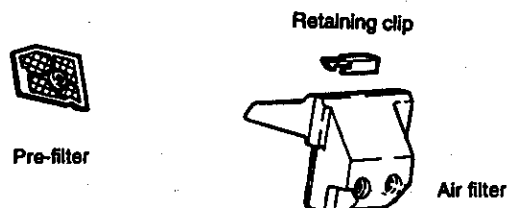

#### REPLACE SPARK PLUG

Change your spark plug each year to make your engine start easy and run better. Set spark plug gap at .020".

#### CLEAN FUEL FILTER

The fuel filter is located inside the fuel tank and is attached to the fuel line. To clean, scrub with a small brush. Replace if deteriorated.

#### INSPECT MUFFLER

Inspect muffler every 25 hours of use and replace if corroded.

#### CLEAN SPARK ARRESTOR SCREEN (if installed)

After every 25 hours of use the spark arrestor screen must be cleaned. Replace screen if deteriorating (part no. 2048391).

To clean:

1. Remove screen.
2. Clean using a wire brush.
3. Reinstall.

## SERVICE AND ADJUSTMENT

#### CHAIN TENSION

Correct chain tension is very important to insure a long service life for the chain. Check the chain tension each time the saw is stopped and the bar and chain have cooled off. Check the tension and the chain and bar lubrication frequently during prolonged periods of cutting. If the chain is loose, lubricate it well and let it cool off before readjusting the tension.

**WARNING:** Be sure the chain is properly tensioned. A sagging chain can jump out of the bar groove, break, and cause serious injury.

The chain tension needs adjusting if the chain is sagging away from the underside of the bar when the saw is held upright (Fig. 29).

FIGURE 29

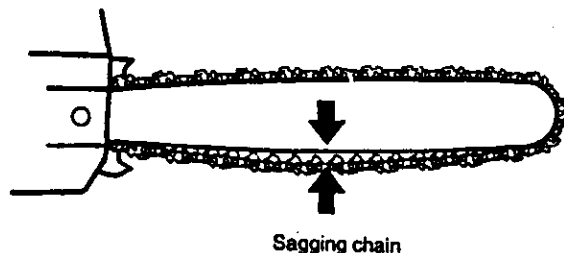

**WARNING:** Shut off engine before attempting to adjust the chain tension. Additionally, disconnect the spark plug wire. Wear gloves when handling chains to prevent injury.

To adjust the tension:

1. Loosen the bar nuts using the Combi-wrench.
2. Turn the tension screw clockwise (Fig. 30, 1) until the chain touches and no longer sags at the underside of the bar.

FIGURE 30

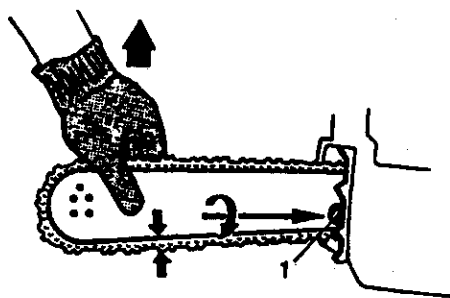

3. The saw chain is correctly tensioned when the chain fits snugly against the underside of the bar, but can still be easily rotated on the bar by hand. Be sure the chain fits correctly on the sprocket and the bar (Fig. 30). **NOTE:** The chain will not rotate if the chain brake is engaged.
4. Hold up the bar tip. Tighten the bar nuts securely with the Combi-wrench provided. Only use the provided Combi-wrench to tighten the bar nuts (Fig. 31). **CAUTION:** Excessive force will strip the bar studs out of the saw case.

FIGURE 31

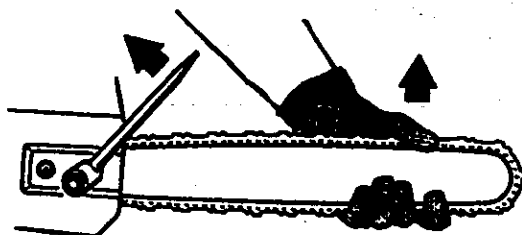

#### INSTALLING NEW CHAIN

**CAUTION:** Injury hazard! Wear safety gloves when handling saw chain at any time.

1. Be sure chain brake is disengaged first (Fig. 32). Pull backwards on hand guard until it clicks audibly. Remove the two bar nuts (Fig. 33) and side cover.

FIGURE 32

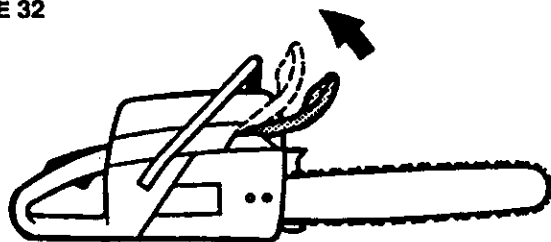
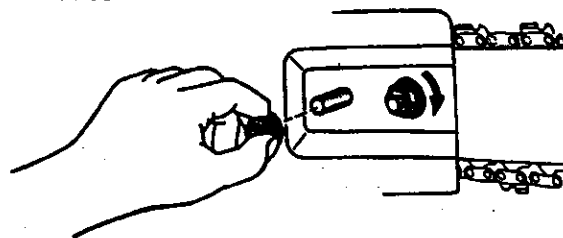
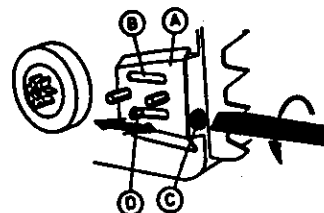

FIGURE 33



2. Clean the surface between the bar and the guide plate (Fig. 34, A); and the oiler opening (Fig. 34, B).
3. Turn the chain tensioning screw (Fig. 34, C) counterclockwise to position the tension lug (Fig. 34, D) to the far left.
4. Slide the bar over the tension lug and fit securely into lughole. Failure to fit the lug into the hole may result in the tension screw being bent when the side cover is tightened down.

FIGURE 34



5. Feed the chain around the chain sprocket into the bar groove (Fig. 35). Cutters (the sharp edge on top) must point forward toward bar nose. Insure the chain drive links engage the chain sprocket and the sprocket nose on the bar.

FIGURE 35

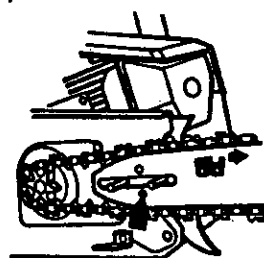

6. Attach the side cover and bar nuts by hand tightening only. Lifting the bar nose slightly; turn the chain clockwise and tighten the chain with the tension screw until the chain touches the bar without sagging. The chain tension is correct if the chain is snug against the underside of the bar but can still be easily rotated by hand. **NOTE:** The chain will not rotate if the chain brake is engaged!
7. Hold bar tip up; tighten bar nuts securely with Combi wrench supplied. **CAUTION:** Excess force will strip the bar studs out of the case.

**NOTE:** Check chain tension frequently. Chain tension will be affected by such conditions as duration of work, outside temperature, hardness of wood, lubrication, etc. If the chain becomes loose, shut off saw, loosen retaining nuts and readjust chain according to previous instructions.

#### **CARBURETOR ADJUSTMENT**

To comply with emission regulations, the carburetor mixture is pre-set at the factory and can not be adjusted without the proper tools. Any mixture adjustment must be performed by a service center.

The idle speed can be adjusted. The idle speed set screw is located on the top of the unit and to the left of the spark plug. It is indicated by the letter "T." To adjust the idle speed, turn clockwise to increase and counterclockwise to decrease idle speed. Idle speed is 2500 ± 100 RPM.

### **STORAGE**

Prepare your chain saw for storage at the end of the season or if the unit will not be used for 30 days or more.

#### **BEFORE STORING**

1. Use soap and water to wipe down unit.
2. Be sure that all nuts, bolts, screws, and fasteners are securely fastened. Inspect for damaged or worn parts. Replace if necessary.

#### **ENGINE**

It is important to prevent gum deposits from forming in essential fuel system parts such as the carburetor, fuel filter, fuel hose, or tank during storage. Alcohol blended fuels, such as gasohol, ethanol, or methanol, can attract moisture, which leads to separation and formation of acids during storage. Acidic gas can damage the fuel system of an engine while in storage. Do not store gasoline from one season to the next. Two-cycle mix ages quickly and can cause engine damage. Replace your gasoline container if it starts to rust. Rust or dirt in your gasoline will cause engine problems.

To avoid engine problems, the fuel system should be emptied before storage of 30 days or more.

Follow these instructions:

1. Drain the fuel tank.
2. Start engine and let it run until the fuel lines and carburetor are empty (The engine will stop.)
3. Use fresh gas next season.
4. If you use a fuel stabilizer, the gasoline can be left in the tank. **CAUTION:** Never store chain saw inside a building with fuel in the tank! Fumes can concentrate and possibly reach a source of ignition. Allow engine to cool before storage.
5. Remove spark plug.

6. Pour a few drops of oil into the cylinder.
7. Pull the starter handle slowly to distribute the oil.
8. Replace with new spark plug.

#### **STORAGE TIPS**

If possible, store your unit indoors and cover it to give it protection from dust and dirt. Do not use plastic. Plastic cannot breathe, which will allow condensation to form and will cause your unit to rust. **IMPORTANT!** Never cover chain saw while engine and muffler are still warm.

## TROUBLESHOOTING

PROBLEM	CAUSE	SOLUTION
Engine does not start.	<ol style="list-style-type: none"> <li>1. Fuel tank is empty.</li> <li>2. Stale fuel mix.</li>   <li>3. Ignition switch off.</li> <li>4. Spark plug fouled.</li> </ol>	<ol style="list-style-type: none"> <li>1. Refuel with fresh fuel.</li> <li>2. Drain and flush the fuel tank. Refuel with fresh fuel mix. See "Fuel Mixture Chart" in Operations.</li> <li>3. Set switch to "I."</li> <li>4. Clean or replace plug.</li> </ol>
Chain rotates in idle mode.	<ol style="list-style-type: none"> <li>1. Idle speed too fast.</li> </ol>	<ol style="list-style-type: none"> <li>1. Turn idle speed set screw counterclockwise until chain stops while the engine idles.</li> </ol>
Exhaust is smokey.	<ol style="list-style-type: none"> <li>1. Idle speed mixture too rich.</li> <li>2. Too much oil in fuel mixture.</li>   <li>3. Air filter clogged.</li> <li>4. Choke only partially open.</li> </ol>	<ol style="list-style-type: none"> <li>1. Contact Sears Service Center.</li> <li>2. Adjust the fuel-oil mixture ratio.</li> <li>3. Clean or replace air filter.</li> <li>4. Open choke all the way.</li> </ol>
Chain cuts poorly.	<ol style="list-style-type: none"> <li>1. Blunt chain or incorrectly sharpened.</li> <li>2. Carburetor adjusted incorrectly.</li> <li>3. Air filter clogged.</li> </ol>	<ol style="list-style-type: none"> <li>1. Sharpen chain.</li>   <li>2. Contact Sears Service Center.</li>   <li>3. Clean or replace air filter.</li> </ol>

## CALIFORNIA EMISSION CONTROL WARRANTY STATEMENT

The California Air Resources Board and Sears are pleased to explain the emission control system warranty on your 1996 and later lawn and garden equipment engine. In California, new lawn and garden equipment engines must be designed, built, and equipped to meet the state's stringent anti-smog standards. Sears must warrant the emission control system on your lawn and garden equipment engine for the period of time listed below provided there has been no abuse, neglect, or improper maintenance of your lawn and garden equipment engine.

Your emission control system includes parts such as the carburetor or fuel injected system, the ignition system, and connectors and other emission-related assemblies.

Where a warrantable condition exists, Sears will repair your lawn and garden equipment engine at no cost to you including diagnosis, parts, and labor.

### MANUFACTURER'S WARRANTY COVERAGE:

The 1996 and later lawn and garden equipment engines are warranted for two years. If any emission-related part on your engine is defective, the part will be repaired or replaced by Sears.

### OWNER'S WARRANTY RESPONSIBILITIES:

As the lawn and garden equipment engine owner, you are responsible for the performance of the required maintenance listed in your Operator's Manual. Sears recommends that

you retain all receipts covering maintenance on your lawn and garden equipment engine. Sears cannot deny warranty solely for the lack of receipts or for your failure to ensure the performance of all scheduled maintenance.

As the lawn and garden equipment engine owner, you should however be aware that Sears may deny you warranty coverage if your lawn and garden equipment engine or a part has failed due to abuse, neglect, improper maintenance or unapproved modifications.

You are responsible for presenting your lawn and garden equipment engine to a Sears repair center as soon as a problem exists. The warranty repairs should be completed in a reasonable amount of time, not to exceed 30 days.

If you have any questions regarding your warranty rights and responsibilities, you should contact Sears at 1-800-473-7247.

### A. WARRANTY COMMENCEMENT DATE

The warranty period begins on the date the equipment is purchased by a retail customer.

### B. LENGTH OF WARRANTY COVERAGE

Sears warrants to the initial owner and each subsequent purchaser that the engine is free from defects in materials and workmanship for a period of two years from date of original purchase from Sears.

## C. WHAT IS COVERED

### 1. REPAIR OR REPLACEMENT OF PARTS

Repair or replacement of any warranted part will be performed at no charge to the owner at a warranty station. To locate a warranty station, you may call Sears at 1-800-473-7247, (24 hours, 7 days a week).

### 2. WARRANTY PERIOD

Any warranted part which is not scheduled for replacement as required maintenance, or which is scheduled only for regular inspection to the effect of "repair or replace as necessary" shall be warranted for the warranty period. Any warranted part which is scheduled for replacement as required maintenance shall be warranted for the period of time up to the first scheduled replacement point for that part.

### 3. DIAGNOSIS

The owner shall not be charged for diagnostic labor, which leads to the determination that a warranted part is defective, if the diagnostic work is performed at Sears.

### 4. CONSEQUENTIAL DAMAGES

The engine manufacturer is liable for damages to the engine components caused by the failure of a warranted part still under warranty.

## D. WHAT IS NOT COVERED

1. Failures caused by abuse, neglect, or improper maintenance.
2. Add-on or modified parts. The use of add-on or modified parts can be grounds for disallowing a warranty claim. The engine manufacturer is not liable to cover failures of warranted parts caused by the use of add-on or modified parts.
3. Any indirect or consequential damages that may result from the failure or malfunction of the Sears product. Some states do not allow the exclusion or limitation of consequential damages so these limitations may not apply to you.
4. Normal service requirements arising during the warranty period such as carburetor or ignition adjustment, cleaning, normal wear, lubrication, spark plugs, filters, starter ropes, etc.
5. Normal service work over and above the repair or replacement of defective parts.

6. Any failure that results from an accident, customer abuse, normal wear, neglect or failure to operate the product in accordance with the instructions provided in the Operators Manual or provided with the product.
7. Pre-delivery set-up time.
8. Operation of an engine with an incorrect fuel:oil ratio, air filter removed or speeds in excess of Sears' recommendations (if applicable).
9. Transportation costs associated with delivering and return of product to a Sears warranty station.

## E. HOW TO FILE A CLAIM

Warranty claims may be submitted on several different forms:

Sears Warranty Claim Request  
Outdoor Power Equipment Institute  
Universal Warranty Claim Report  
Engine Service Association Claim

Warranty claims must be received at Sears within 60 days of the date of repair noted on the claim.

## F. WHERE TO GET WARRANTY SERVICE

Warranty service or repairs shall be provided at Sears Service Centers. For the address of a Service Center near you call Sears at 1-800-473-7247, (24 hours, 7 days a week).

## G. MAINTENANCE, REPLACEMENT AND REPAIR OF EMISSION RELATED PARTS

Sears replacement parts must be used in the performance of any warranty maintenance or repairs on emission-related parts and will be provided without charge during the warranty period.

## H. EMISSION CONTROL WARRANTY PARTS LIST

Sears' warranty includes the following parts (unless said part was scheduled for replacement as required maintenance): Air Filter, Fuel Filter, Carburetor and internal parts, Choke Mechanism, Intake Manifold, Spark Plug, Flywheel, Ignition Module.

## I. MAINTENANCE STATEMENTS

Follow normal maintenance service, recommended fuel mixture (where applicable), lubrication, operation and storage of the product as explained in the Operator's Manual. The owner shall not be charged for diagnostic labor, which leads to the determination that a warranted part is defective, if the diagnostic work is performed at Sears.



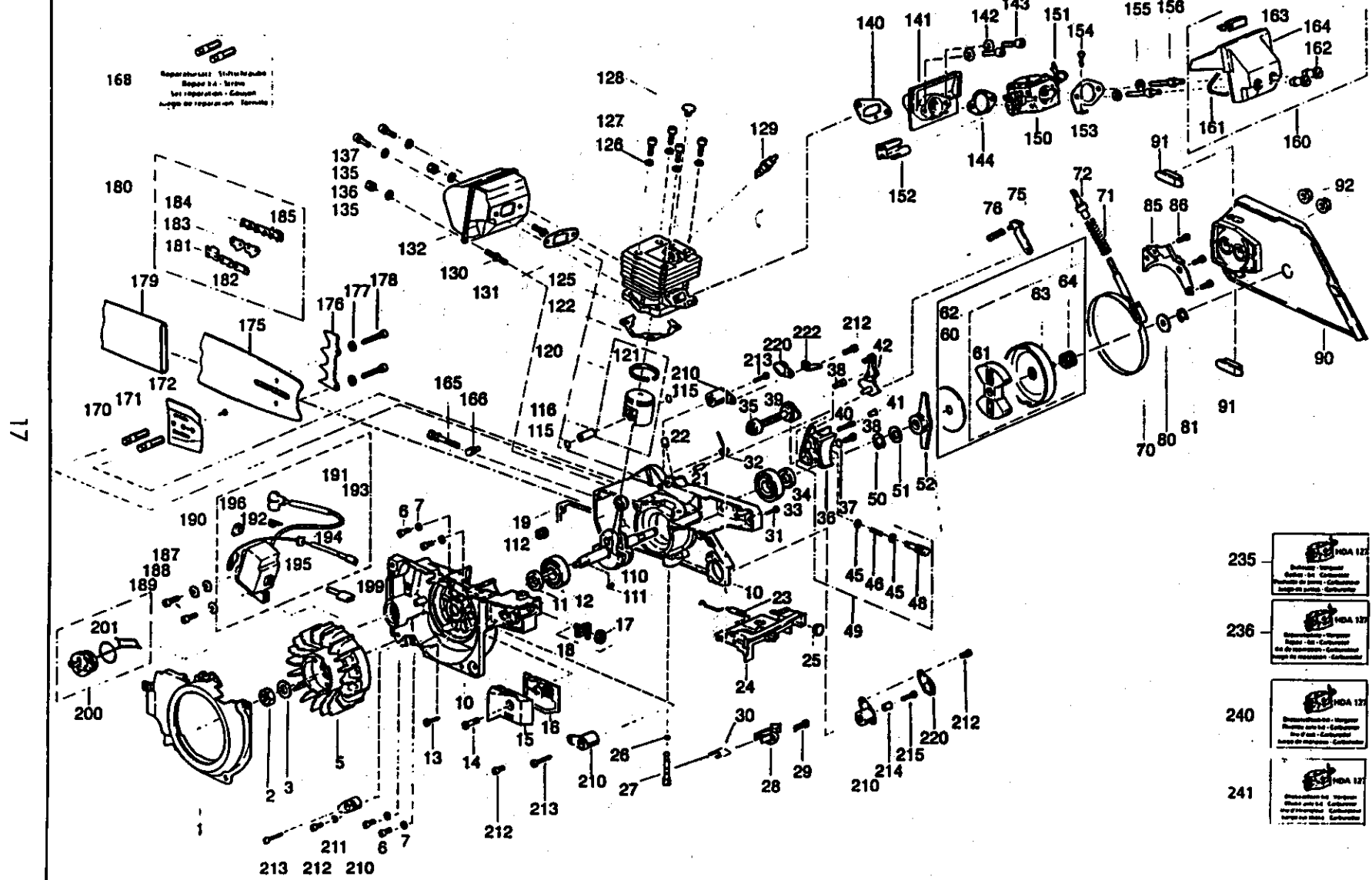

**CRAFTSMAN CHAIN SAW MODEL NO. 360.352001**



168  
 Reparatörler: Silföretag  
 Repair: Sears  
 Les réparateurs: C&S  
 Loja de reparación: Ferrería

17

PARTS

- 235  HDA 127  
 Reparatörler: Silföretag  
 Repair: Sears  
 Les réparateurs: C&S  
 Loja de reparación: Ferrería
- 236  HDA 127  
 Reparatörler: Silföretag  
 Repair: Sears  
 Les réparateurs: C&S  
 Loja de reparación: Ferrería
- 240  HDA 127  
 Reparatörler: Silföretag  
 Repair: Sears  
 Les réparateurs: C&S  
 Loja de reparación: Ferrería
- 241  HDA 127  
 Reparatörler: Silföretag  
 Repair: Sears  
 Les réparateurs: C&S  
 Loja de reparación: Ferrería



**CRAFTSMAN CHAIN SAW MODEL NO. 360.352001**

Pos. Number

Part

Number Description

Pos.

Part

Number Description

1	6073641	Air guide	121	2048357	Piston ring
2	0020145	Nut	122	2061478	Cylinder foot gasket
3	0072145	Tension spring	125	2011756	Cylinder
5	2400289	Flywheel	126	0034201	Circlip
6	0010158	Screw	127	0010541	Screw
7	0034201	Circlip	128	0094252	Spacer
10	2100624DGN	Crankcase, complete	129	2300730	Spark plug
11	0054252	Oil seal	130	0015286	Stud screw
12	0050187	Grooved ball bearing	131	2061441	Muffler gasket
13	0018267	Screw	132	2500604	Muffler
14	0018336	Screw	135	0072144	Washer
15	2074416DGN	Pre-filter cover	136	0028137	Lock nut
16	2500582	Pre-filter assembly	137	0018336	Screw
17	0021232	Nut	140	2061439	Manifold gasket
18	2300469	Short circuit switch	141	2300732	Manifold
19	2061473	Crankcase gasket	142	0034201	Circlip
21	0040190	Pin	143	0010112	Screw
22	2700382	Check valve	144	2061443	Carburetor gasket
23	2800285	Throttle linkage	150	2300709	Carburetor
24	2074908DGN	Console	151	6074916	Lever
25	6074401	Plug	152	2074441	Guide nozzle
26	0062256	O-ring	153	6043247	Support
27	6400183	Pin	154	0018267	Screw
28	6074409	Stop plate	155	0034147	Spring ring
29	0018280	Screw	156	0015279	Screw
30	2042726	Stop plate	160	2500641	Air filter assembly
31	0018267	Screw	161	0062246	O-ring
32	0073381	Torsion spring	162	0011282	Screw
33	0050188	Ball bearing	163	2074946	Profile
34	0054265	Oil seal	164	2074423	Filter housing
35	6063329	Oil hose	165	0018230	Tension screw
36	6400209	Pump housing	166	6032640	Chain tension bolt
37	0062276	O-ring	168	6900814	Repair kit
38	0018280	Screw	170	0018398	Screw
39	6700124	Oil strainer	171	6043329	Guide plate
40	6063299	Hose	172	0010478	Screw
41	0044271	Rivet	175	6900221N	Guide bar
42	6074447	Cover	176	6043323	Bucking spike
45	0031529	Friction washer	177	0034201	Circlip
46	0070265	Pressure spring	178	0010559	Screw
48	6031330	Pump piston	179	6071248	Scabbard
49	6400207	Oil pump, complete	180	6900220N	Chain
50	0055136	Circlip	187	0030101	Washer
51	0031209	Washer	188	0072148	Tension spring
52	6074976	Driving worm	189	0018327	Screw
60	6042817	Washer	190	2300752	Ignition coil
61	0071172	Clutch spring	191	0084600	Spark plug cap
62	3500405	Clutch, complete	192	0073385	Contact spring
63	3500372	Clutch drum	193	0064292	Hose
64	0052257	Needle bearing	194	2063333	Grommet
70	6200131	Brake band	195	0084702	Short circuit cable
71	0070254	Spring	196	0066335	Grommet
72	6300208	Adjuster	199	0066314	Grommet
75	6300175	Pressure plate	200	2700345	Oil tank cap
76	0070253	Spring	201	0062288	O-ring
80	0031534	Washer	210	6300155	Rubber metal connection
81	0055104	Washer	211	0030115	Washer
85	6074999	Brake band cover	212	0018280	Screw
86	0018280	Screw	213	0018274	Screw
90	6100371DGN	Chain Guard	214	0033318	Spacer tube
91	6074696	Guide shoe	215	0018257	Screw
92	00202147	Nut	220	6074422DGN	Protective cap
110	2200238	Crankshaft	222	6043352	Chain protection plate
111	0075100	Disc spring	235	0510952	Carburetor gasket kit
112	0052255	Needle bearing	236	0510951	Carburetor repair kit
115	0055267	Piston pin circlip	240	0510953	Throttle axle kit
116	2031249	Piston pin	241	0510965	Choke axle kit
120	2200265	Piston			

**CRAFTSMAN CHAIN SAW MODEL NO. 360.352001**

Pos. Number	Part Number	Description	Pos. Number	Part Number	Description
1	6100413DGN	Main housing	57	0072140	Spring washer
3	0073392	Throttle control spring	58	6032639	Bolt
4	2074429	Gas lever	60	0028118	Nut
5	0073339	Spring	61	6032669	Bolt
6	6074292	Stop lever	62	6063328	Fuel hose
7	6074443	Safety lever	63	0013214	Screw
8	2036381	Throttle linkage	64	2500744	Ventilation hose
9	0010531	Screw	65	0067124	Nipple
15	6073681	Grip cup, left	66	6063304	Vent hose
16	0010512	Screw	67	6063302	Fuel hose
17	0010531	Screw	68	0073351	Hose loop
20	6073681DGN	Grip cup, left	69	6063301	Hose guide
21	0070147	Spring	70	2700321	Hose
22	6074381	Lever	71	0063191	Sealing cord
23	6031247	Pin	72	2074469	Plug
25	0061356	Gasket	73	2074470	Frame
26	2700353	Tank lid	75	6073683	Cover, Black
28	0098140	Safety catch	76	6800334	Screw
29	0018274	Screw	79	0018336	Screw
30	6800241	Handle bar	80	0018337	Screw
33	0094288	Rubber metal connection	82	6074993	Choke lever
34	0030102	Washer	83	6074992	Pin
35	0098141	Safety catch	85	2700322	Primer
37	0028130	Nut	86	0064407	Hose
38	0018274	Screw	87	0064432	Hose
42	0018274	Screw	88	6074958	Primer support
43	0010157	Screw	89	6042753	Isolating foil
44	0030102	Washer	90	0094252	Rubber spacer
45	0098142	Safety catch	100	6073566	Hub cover, black
47	0098143	Safety catch	104	6074426	Choke lever
50	6800235	Hand protection	105	0011258	Screw
52	0044280	Rivet	106	0030108	Washer
53	0034152	Circlip	110	2700354	Fuel pick-up, complete
54	0010188	Screw	111	2700327	Fuel pick-up
			112	2700335	Fuel pick-up, incl in 6100402

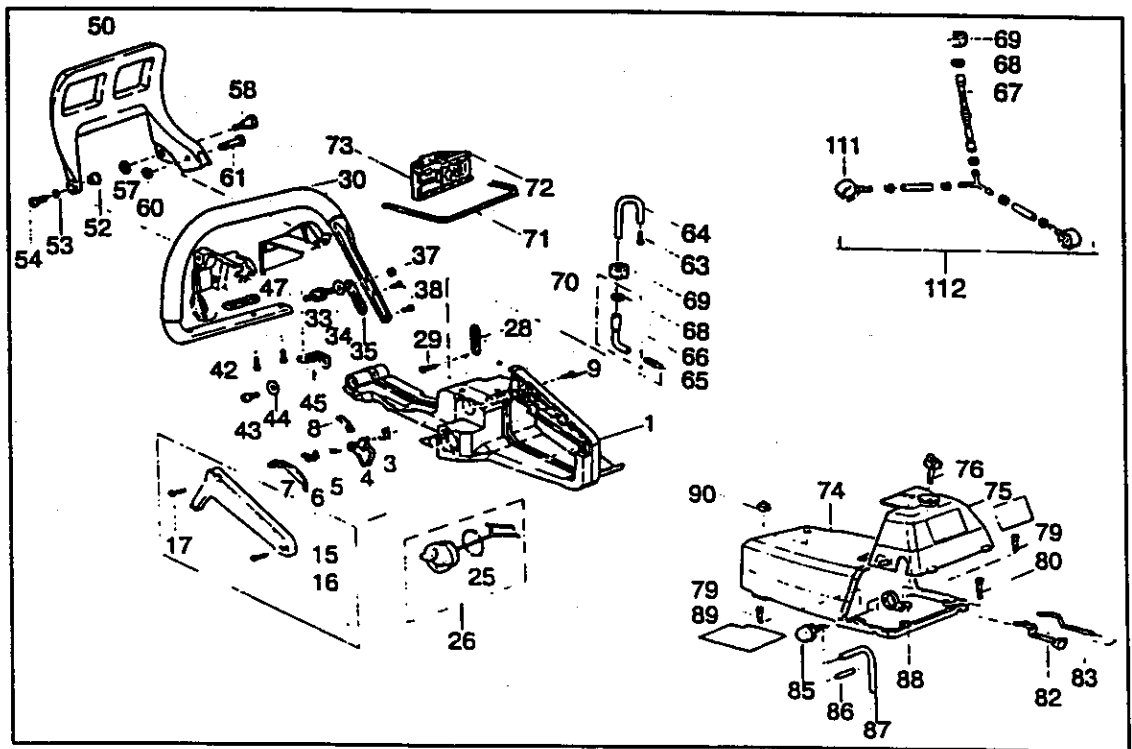

**CRAFTSMAN CHAIN SAW MODEL NO. 360.352001**

Pos. Number	Part	Description
1	2600282DGN	Starter, complete
3	0018336	Screw
4	2100578	Starter housing
5	0063186	Starter rope
6	2074206	Starter handle
7	2600283	Spring cassette
10	2074419	Starter pulley
11	0031260	Washer
12	2074209	Starter pawl
13	2074408	Template
14	0073365	Pin

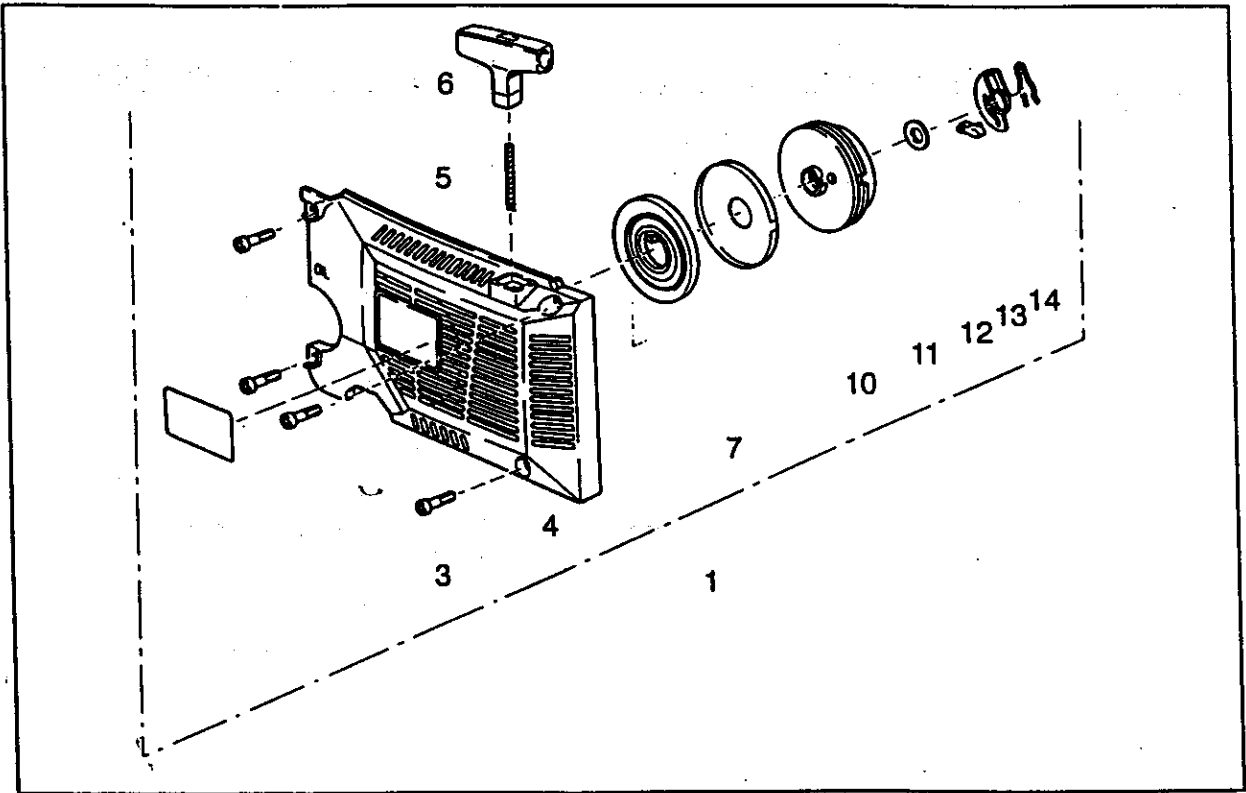

**For in-home major brand repair service:**

Call 24 hours a day, 7 days a week

**1-800-4-MY-HOME<sup>SM</sup>** (1-800-469-4663)

**Para pedir servicio de reparación a domicilio – 1-800-676-5811**

In Canada for all your service and parts needs call **– 1-800-665-4455**  
Au Canada pour tout le service ou les pièces

**For the repair or replacement parts you need:**

Call 6 a.m. – 11 p.m. CST, 7 days a week

**PartsDirect<sup>SM</sup>**

**1-800-366-PART** (1-800-366-7278)

**Para ordenar piezas con entrega a domicilio – 1-800-659-7084**

**For the location of a Sears Service Center in your area:**

Call 24 hours a day, 7 days a week

**1-800-488-1222**

**To purchase or inquire about a Sears Maintenance Agreement:**

Call 7 a.m. – 5 p.m. CST, Monday – Saturday

**1-800-488-6655**

