

SEARS

operator's manual

MODEL NO. 143.994012
4.0 RESERVE POWER
10 INCH CUBIC (163 cc)
DISPLACEMENT

SOLID STATE IGNITION

CAUTION:

Read RULES for
Safe OPERATION
and INSTRUCTIONS
Carefully

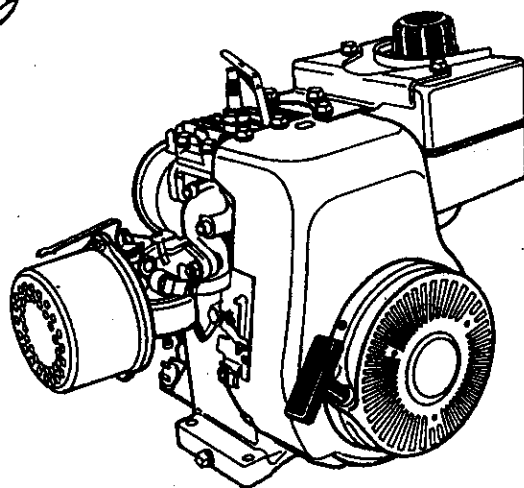
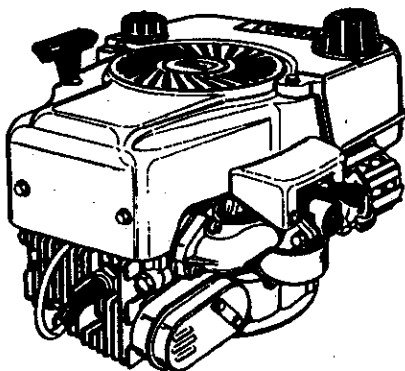

ENGINE

- Operating
- Maintenance
- Repair Parts



California Proposition 65 **WARNING:** The engine exhaust from this product contains chemicals known to the State of California to cause cancer, birth defects or other reproductive harm.

Sold by SEARS, ROEBUCK AND CO., CHICAGO, IL 60684 U.S.A.
and SEARS CANADA, INC., TORONTO, ONTARIO, CANADA

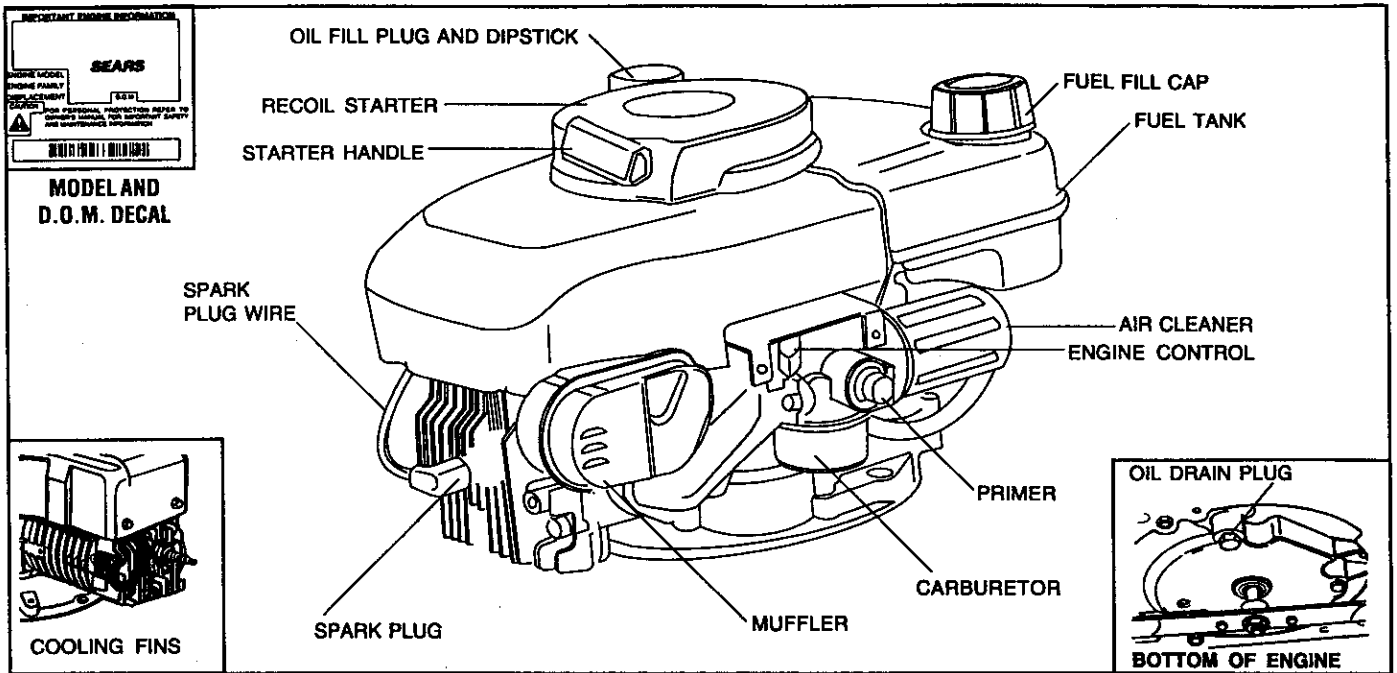

Figure 1



THIS SYMBOL POINTS OUT IMPORTANT SAFETY INSTRUCTIONS WHICH IF NOT FOLLOWED COULD ENDANGER THE PERSONAL SAFETY AND/OR PROPERTY OF YOURSELF AND OTHERS. READ AND FOLLOW ALL INSTRUCTIONS IN THIS MANUAL AND ANY PROVIDED WITH THE EQUIPMENT ON WHICH THIS ENGINE IS USED BEFORE ATTEMPTING TO OPERATING.



THESE SYMBOLS MAY APPEAR ON THE ENGINE:



FAST



SLOW



STOP



OFF



CHOKE



FULL

ENGINES WHICH ARE CERTIFIED TO COMPLY WITH CALIFORNIA AND US EPA EMISSION REGULATIONS FOR ULGE ENGINES: Are certified to operate on regular unleaded gasoline. Include the following emission control system(s): EM, TWC (if so equipped); Do not include any user adjustable features - therefore no other adjustments are needed.

See "STORAGE" instructions of Page 4.

NOTE: Use clean oil and fuel and store in approved, clean covered containers. Use clean fill funnels.

Never use "stale" gasoline left over from last season or stored for long periods.

OIL & FUEL RECOMMENDATIONS

TO OPERATE ENGINE, YOU WILL NEED THE FOLLOWING:

① A CLEAN, HIGH QUALITY, DETERGENT OIL.

Be sure original container is marked:
A.P.I. service "SF"- "SJ".

FOR SUMMER (ABOVE 32°F;0°C) USE SAE 30 OIL.

Using multigrade oil will increase oil consumption.

FOR WINTER (BELOW 32°F;0°C) USE SAE 5W30 OIL.

(SAE 10W is an acceptable substitute.)

DO NOT USE SAE 10W40 OIL.

OIL SUMP CAPACITY: 21 ounces (1-1/4 U.S. pints)
.62 liter

② A FRESH, CLEAN, UNLEADED REGULAR, UNLEADED PREMIUM, OR REFORMULATED AUTOMOTIVE GASOLINE ONLY. DO NOT USE LEADED GASOLINE.

NOTE: DO NOT USE GASOLINE CONTAINING METHANOL (WOOD ALCOHOL). Gasoline containing up to 10% ethanol or grain alcohol ("Gasohol"), or up to 15% MTBE (Methyl Tertiary Butyl Ether), may be used but requires special care when engine is unused for extended periods.

IMPORTANT

KEEP THIS MANUAL HANDY AT ALL TIMES FOR FUTURE REFERENCE. READ IT CAREFULLY AND FAMILIARIZE YOURSELF WITH THE OPERATING, MAINTENANCE AND SAFETY INSTRUCTIONS. THIS MANUAL ALSO CONTAINS A COMPLETE PARTS LISTING.

BEFORE STARTING

① **READ ALL INSTRUCTIONS PROVIDED WITH THE EQUIPMENT ON WHICH THIS ENGINE IS USED.**

THIS ENGINE IS EQUIPPED WITH A FEDERALLY MANDATED MECHANISM WHICH STOPS THE ENGINE. DO NOT INTERFERE WITH OR BYPASS THIS MECHANISM. PARTS OF THE MECHANISM MAY BE SUBJECT TO WEAR AND MUST BE CHECKED ONCE A YEAR BY AN AUTHORIZED SEARS ROEBUCK AND CO. (OR SEARS CANADA, INC.) SERVICE CENTER. IN THE EVENT THE MECHANISM FAILS FOR ANY REASON, YOU MUST NOT USE THE ENGINE UNTIL CORRECTED BY AN AUTHORIZED SEARS ROEBUCK AND CO. (OR SEARS CANADA, INC.) SERVICE CENTER.

DISCONNECT SPARK PLUG WIRE FROM SPARK PLUG AND ATTACH IT TO RETAINING POST (see Figure 6 on Page 3).

BEFORE STARTING (Continued)

② INSTALL ENGINE BRAKE CABLE AND STARTER ROPE: BRAKE CABLE (see Figure 2):

Attach engine brake cable to brake mechanism as shown.

WARNING: Use only the cable screw that came with the engine brake cable. If the cable screw has been lost, get a new one from a Sears, Roebuck and Co. (or Sears Canada, Inc.) Service Center. Any cable screw used must be the same length as the original cable screw.

STARTER ROPE:

- Depress mower control bar (see Figure 3) against mower handle and hold it in this position.
- Pull at least 2 feet of starter rope out of starter and tie a slip knot at starter to prevent starter rope from rewinding back into starter.
- Slide rope stop (see Figure 2) onto starter rope and feed starter rope through rope guide on mower handle (see Figure 4).
- Feed starter rope through starter handle (see Figure 5) and tie a left hand knot, leaving 1/2 inch to 1 inch of starter rope extending beyond knot. **DO NOT PULL LEFT HAND KNOT INTO STARTER HANDLE YET.**
- With starter handle resting on rope guide (see Figure 4), check starter rope for slack. If there is any slack, pull more starter rope through starter handle and relocate left hand knot to eliminate slack.
- Untie slip knot at starter.
- Pull left hand knot into starter handle.
- Position rope stop 2 to 3 inches from starter (see Figure 2) and fasten it to starter rope by gripping it with pliers and forcing staple through starter rope until staple is even with out side of rope stop.

③ CHECK OIL LEVEL:

CAUTION: NEVER RUN ENGINE UNLESS OIL LEVEL IS BETWEEN "FULL" AND "ADD" MARKS ON DIPSTICK. CHECK OIL LEVEL OFTEN DURING ENGINE BREAK-IN. NEVER RUN ENGINE UNLESS OIL FILL PLUG IS TIGHTENED SECURELY INTO OIL FILL HOLE.

- POSITION EQUIPMENT SO ENGINE IS LEVEL.
- Clean area around oil fill plug (see Figure 1).
- Remove oil fill plug and dipstick.
- Wipe dipstick clean, insert it into oil fill hole and tighten securely.
- Remove oil fill plug and check oil level. If level is not up to "FULL" mark on dipstick, add recommended oil, until it is. **POUR SLOWLY.** Wipe dipstick clean each time oil level is checked. **DO NOT FILL ABOVE "FULL" MARK ON DIPSTICK.**
- Replace oil fill plug and tighten securely. See "MAINTENANCE" section for any future oil level and oil change instructions (see Page 3).

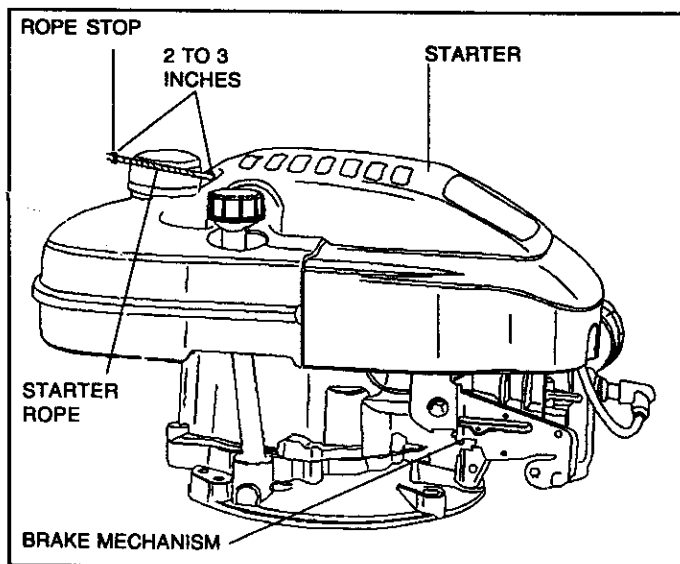

Figure 2

BEFORE STARTING (Continued)

④ FILL FUEL TANK with gasoline as specified in the preceding "OIL & FUEL RECOMMENDATIONS," item 2.

NEVER MIX OIL WITH GASOLINE

Never use "stale" gasoline left over from last season or stored for long periods.

⚠ NEVER FILL FUEL TANK INDOORS. NEVER FILL FUEL TANK WHEN ENGINE IS RUNNING OR HOT. DO NOT SMOKE WHEN FILLING FUEL TANK.

⚠ NEVER FILL FUEL TANK COMPLETELY. FILL TANK TO 1/2" BELOW BOTTOM OF FILLER NECK TO PROVIDE SPACE FOR FUEL EXPANSION. WIPE ANY FUEL SPILLAGE FROM ENGINE AND EQUIPMENT BEFORE STARTING ENGINE.

⚠ ANY LIQUEFIED PETROLEUM (LPG) OR NATURAL GAS FUEL SYSTEM MUST BE LEAKPROOF AND MEET ALL APPLICABLE CODES AND REGULATIONS.

⑤ CHECK THE FOLLOWING:

⚠ A. BE SURE EQUIPMENT IS IN NEUTRAL GEAR WITH CLUTCHES, BELTS, CHAINS AND SAFETY SWITCHES DISENGAGED. (FOLLOW EQUIPMENT MANUFACTURER'S INSTRUCTIONS). THIS SHOULD PLACE ANY SAFETY SWITCHES IN SAFE STARTING POSITION.

B. Be sure spark plug wire is attached to spark plug (see Figure 1).

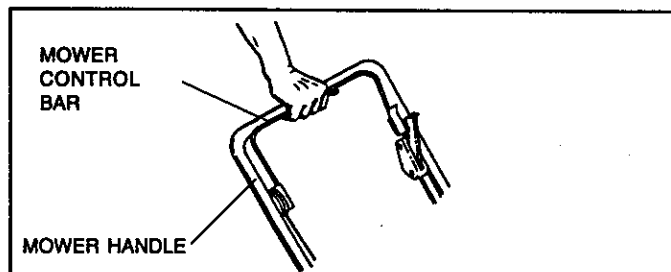

Figure 3

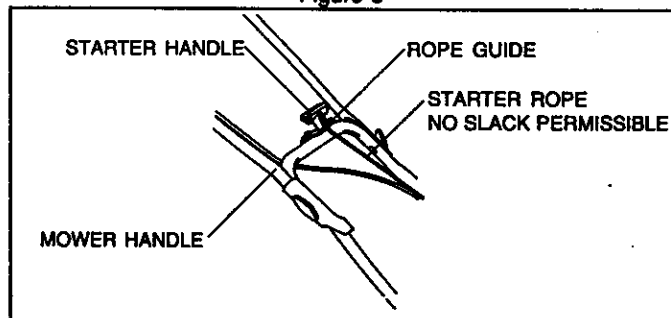

Figure 4

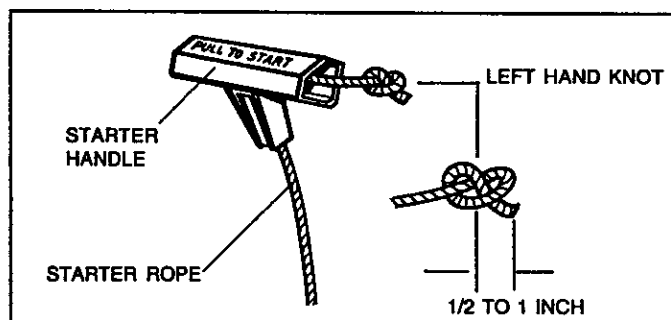

Figure 5

STARTING

⚠ NEVER RUN ENGINE INDOORS OR IN ENCLOSED, POORLY VENTILATED AREAS. ENGINE EXHAUST CONTAINS CARBON MONOXIDE, AN ODORLESS AND DEADLY GAS (CARBON MONOXIDE IS ALSO PRESENT IN ENGINE EXHAUST FROM LIQUID PETROLEUM (LPG) AND NATURAL GAS FUEL SYSTEMS).

⚠ KEEP HANDS, FEET, HAIR AND LOOSE CLOTHING AWAY FROM ANY MOVING PARTS ON ENGINE AND EQUIPMENT.

⚠ WARNING TEMPERATURE OF MUFFLER AND NEARBY AREAS MAY EXCEED 150°F (65°C). AVOID THESE AREAS.

① Move engine control (see Figure 1) to HI Position.

② START ENGINE:

A. The carburetor on your engine has been completely adjusted at the factory. When starting a cold engine, push red primer bulb firmly with your thumb 5 times, allowing primer bulb to return completely to original position between pushes. Repeat the above for each starter operation as necessary.

NOTE: DO NOT USE PRIMER TO RESTART A WARM ENGINE AFTER A SHORT SHUTDOWN.

B. Operate mower control to release engine brake.

C. Grasp starter handle (see Figure 4) and pull rope out, slowly, until it pulls slightly harder. Let rope rewind slowly. Then pull rope with a rapid full arm stroke. Let rope rewind SLOWLY. Do not let starter handle snap back against rope guide (see Figure 4).

D. Repeat instructions B and C if necessary, until engine starts. **NOTE:** If engine does not start, repeat instructions A, B, C and D until it starts.

ENGINE SPEED: Engine speed is controlled by the engine control (see Figure 1). Engine control should be in HI position for high grass conditions and for most efficient bagging in heavy grass conditions, and in LOW position for light grass, trimming and for fuel economy.

STOPPING

① See mower manufacturer's instructions.

② AFTER ENGINE IS STOPPED:

⚠ A. DISCONNECT SPARK PLUG WIRE FROM SPARK PLUG AND ATTACH IT TO RETAINING POST (see Figure 6).

⚠ B. NEVER STORE ENGINE WITH FUEL IN TANK INDOORS OR IN ENCLOSED, POORLY VENTILATED AREAS, WHERE FUEL FUMES MAY REACH AN OPEN FLAME, SPARK OR PILOT LIGHT AS ON A FURNACE, WATER HEATER, CLOTHES DRYER OR OTHER GAS APPLIANCE.

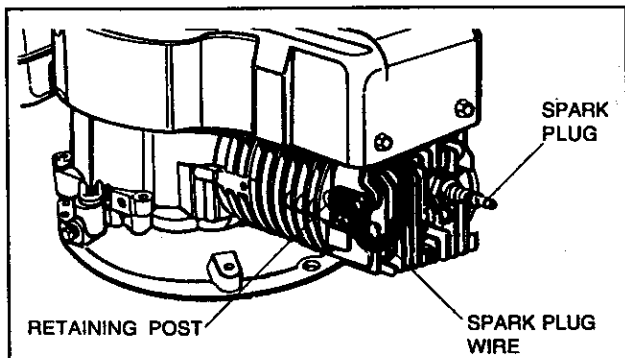

Figure 6

MAINTENANCE

⚠ WARNING: TEMPERATURE OF MUFFLER AND NEARBY AREAS MAY EXCEED 150°F (65°C). AVOID THESE AREAS.

① CHECK OIL LEVEL:

Check oil level every five (5) operating hours or each time engine is used. See "3 CHECK OIL LEVEL" in "BEFORE STARTING" on Page 2.

② CHANGE OIL:

Change oil after first two (2) operating hours and every 25 operating hours thereafter, more often if operated in extremely dusty or dirty conditions. Change oil while engine is still warm from recent running.

⚠ A. DISCONNECT SPARK PLUG WIRE FROM SPARK PLUG AND ATTACH IT TO RETAINING POST (see Figure 6).

B. Position equipment so engine oil drain plug is lowest point on engine.

C. Remove oil drain plug and oil fill plug to drain oil (see Figure 1).

D. Replace oil drain plug and tighten securely.

E. Fill oil sump with recommended oil. See "OIL & FUEL RECOMMENDATIONS" and "CHECK OIL LEVEL" on Page 1.

F. Replace oil fill plug and tighten securely.

G. Connect spark plug wire to spark plug.

H. Wipe up any spilled oil and/or gasoline

NOTE: If it is difficult to reach the oil drain plug, drain fuel. Remove oil fill plug and tip mower on its side. Drain oil into a suitable container.

③ AIR CLEANER (see Figure 7):

NEVER RUN ENGINE WITHOUT COMPLETE AIR CLEANER INSTALLED ON ENGINE.

Replace filter once a year or more often if used in extremely dusty or dirty conditions.

DO NOT ATTEMPT TO CLEAN OR OIL FILTER.

Replacement filters are available at any Sears Roebuck and Co. (or Sears Canada, Inc.) Service Center. To install new filter, proceed as follows:

A. Turn cover to the left (counterclockwise) and remove it and filter from flange. Discard filter.

B. Clean cover and flange thoroughly.

C. Insert new filter into cover.

D. Position cover and filter against flange with tab on cover inserted into lower left corner of slot in flange.

E. Push cover firmly against flange and turn it to the right (clockwise) as far as it will go. Be sure retainers are locked around flange.

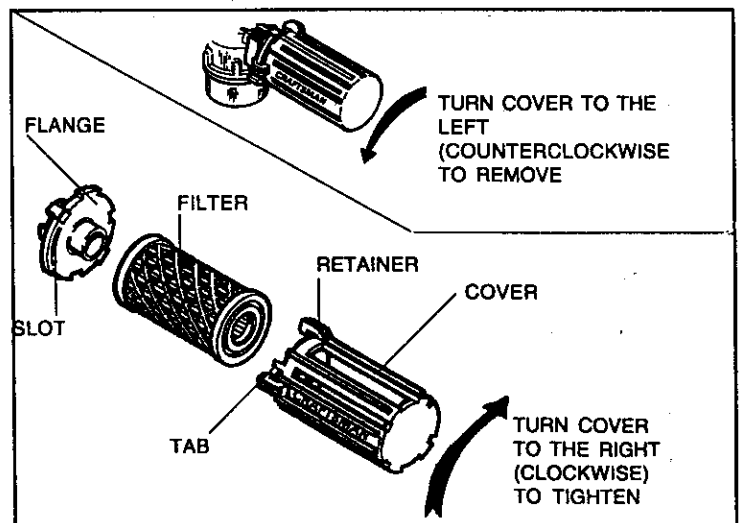

Figure 7

MAINTENANCE (Continued)

④ SPARK PLUG (see Figure 8):

This spark ignition system meets all requirements of the Canadian Interference-Causing Equipment Regulations. This engine complies with all current Australian and New Zealand limitations regarding electromagnetic interference. Check spark plug yearly or every 100 operating hours.

- Clean area around spark plug.
 - Remove and inspect spark plug.
 - Replace spark plug if electrodes are pitted, burned or porcelain is cracked. For replacement use Champion RJ-19LM or equivalent.
- NOTE:** A resistor spark plug must be used for replacement.
- Check electrodes gap with wire feeler gauge and set gap at .030 if necessary.
 - Install spark plug, tighten securely.

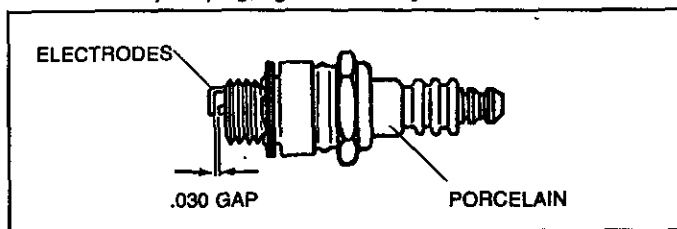

Figure 8

⑤ COOLING SYSTEM:

IMPORTANT: Frequently remove any grass clippings, dirt and debris from cooling fins, air intake screen and levers and linkage (see Figure 1). This will help ensure adequate cooling and correct engine speed.

⑥ CHECK ENGINE AND EQUIPMENT OFTEN FOR LOOSE NUTS, BOLTS AND ATTACHMENTS, AND KEEP THESE ITEMS TIGHTENED.

ADJUSTMENTS

DO NOT MAKE UNNECESSARY ADJUSTMENTS. FACTORY SETTINGS ARE SATISFACTORY FOR MOST APPLICATIONS AND CONDITIONS. IF ADJUSTMENTS ARE NEEDED, PROCEED AS FOLLOWS:

① CARBURETOR

If you think your carburetor needs adjusting, see your nearest SEARS, ROEBUCK AND CO. (OR SEARS CANADA, INC.) SERVICE CENTER. Engine performance should not be affected at altitudes up to 7,000 feet. For operation at higher elevations, contact your nearest SEARS, ROEBUCK AND CO. (OR SEARS CANADA, INC.) SERVICE CENTER.

② ENGINE SPEED

NEVER TAMPER WITH ENGINE GOVERNOR WHICH IS FACTORY SET FOR PROPER ENGINE SPEED. OVERSPEEDING ENGINE ABOVE FACTORY HIGH SPEED SETTING CAN BE DANGEROUS.

CHANGING OF ENGINE-GOVERNED SPEED WILL VOID ENGINE WARRANTY.

STORAGE

NEVER STORE ENGINE WITH FUEL IN TANK INDOORS OR IN ENCLOSED, POORLY VENTILATED AREAS, WHERE FUEL FUMES MAY REACH AN OPEN FLAME, SPARK OR PILOT LIGHT AS ON A FURNACE, WATER HEATER, CLOTHES DRYER OR OTHER GAS APPLIANCE.

IF ENGINE IS TO BE UNUSED FOR 30 DAYS OR MORE, PREPARE AS FOLLOWS:

① DRAIN FUEL SYSTEM:

- Remove all gasoline from carburetor and fuel tank to prevent gum deposits from forming on these parts and causing possible malfunction of engine.

DRAIN FUEL INTO APPROVED CONTAINER OUTDOORS, AWAY FROM OPEN FLAME. BE SURE ENGINE IS COOL. DO NOT SMOKE.

- Run engine until fuel tank is empty and engine stops due to lack of fuel.

NOTE: If "Gasohol" has been used, complete above instructions and then put 1/2 pint of unleaded gasoline into fuel tank and repeat above instructions.

NOTE: Fuel stabilizer (such as STA-BIL) is an acceptable alternative in minimizing the formation of fuel gum deposits during storage. Add stabilizer to gasoline in fuel tank or storage container. Always follow mix ratio found on stabilizer container. Run engine at least 10 minutes after adding stabilizer to allow it to reach carburetor.

② CHANGE OIL:

Change oil if it has not been changed in the last three (3) months. See "CHANGE OIL" instructions in "MAINTENANCE" section on Page 3.

③ OIL CYLINDER BORE:

- Remove spark plug and pour one (1) ounce (30 ml) of engine oil into spark plug hole.
- Cover spark plug hole with a rag.
- Crank engine over, slowly, several times.

AVOID SPRAY FROM SPARK PLUG HOLE WHEN CRANKING ENGINE OVER SLOWLY.

- Replace spark plug.

④ CLEAN ENGINE:

Remove any clippings, dirt, or chaff from exterior of engine.

GENERAL

Just as your automobile needs professional mechanical maintenance from time to time, so does your Craftsman engine. Replacement of the spark plug and air cleaner is made necessary by NORMAL use. Professional Air-Cooled Engine Service is as close as your nearest Sears Roebuck and Co. (or Sears Canada, Inc.) Service Center. A yearly check-up or tune-up by Sears is a good idea to avoid breakdowns or delay... do it at the end of the season, then you're ready for the next. We even prepare it for storage for you.

TROUBLESHOOTING

**THE FOLLOWING MAY HELP AVOID A DELAY IN YOUR WORK OR
SAVE THE EXPENSE OF A SERVICE CALL.**

ENGINE FAILS TO START OR STARTS WITH DIFFICULTY	
CAUSE	REMEDY
Controls not in start position.	Move ENGINE CONTROL or equipment control to "HI" or START position. See "STARTING" instructions in this manual.
Spark plug wire disconnected from spark plug.	Connect SPARK PLUG WIRE to SPARK PLUG.
Spark plug fouled.	Remove SPARK PLUG and clean it. See "SPARK PLUG" instructions in "MAINTENANCE" section in this manual.
Spark plug porcelain cracked.	Install new spark plug.
Insufficient fuel.	Fill FUEL TANK per "BEFORE STARTING" instructions.
Water or dirt in fuel.	Drain FUEL TANK and re-fill with clean, fresh gasoline. See "BEFORE STARTING" instructions in this manual.
Improper carburetor adjustment	Adjust carburetor (if applicable). See "ADJUSTMENTS" section in this manual.
ENGINE LACKS POWER	
CAUSE	REMEDY
Dirty air cleaner.	Replace or clean air cleaner per "AIR CLEANER" instructions in "MAINTENANCE" section in this manual.
Improper carburetor adjustment.	Adjust carburetor (if applicable). See "ADJUSTMENTS" section in this manual.
Lack of lubricaiton.	Fill oil sump to proper level. See "BEFORE STARTING" instructions section in this manual.
ENGINE MISSES UNDER LOAD	
CAUSE	REMEDY
Spark plug fouled.	Remove SPARK PLUG and clean it. See "SPARK PLUG" instructions in "MAINTENANCE" section in this manual.
Spark plug porcelain cracked.	Install new SPARK PLUG.
Improper spark plug gap.	Regap SPARK PLUG electrodes. See "SPARK PLUG" instructions in "MAINTENANCE" section in this manual.
Improper carburetor adjustment	Adjust carburetor (if applicable). See "ADJUSTMENTS" section in this manual.

SEARS, ROEBUCK AND CO.

Federal and California Emission Control Systems Limited Warranty Utility and Lawn and Garden Engines

CALIFORNIA & US EPA EMISSION CONTROL WARRANTY STATEMENT

The U. S. Environmental Protection Agency ("EPA"), the California Air Resources Board ("CARB") and Sears, Roebuck and Co. are pleased to explain the Federal and California Emission Control Systems Warranty on your new utility or lawn and garden equipment engine. In California, new 1995 and later utility and lawn and garden equipment engines must be designed, built and equipped to meet the State's stringent anti-smog standards. In other states, new 1997 and later model year engines must be designed, built and equipped, at the time of sale, to meet the U.S. EPA regulations for small non-road engines. Sears, Roebuck and Co. will warrant the emission control system on your utility or lawn and garden equipment engine for the periods of time listed below, provided there has been no abuse, neglect, unapproved modification, or improper maintenance of your utility or lawn and garden equipment engine.

Your emission control system may include parts such as the carburetor, ignition system and exhaust system. Also included may be the compression release system and other emission-related assemblies.

Where a warrantable condition exists, Sears, Roebuck and Co. will repair your utility or lawn and garden equipment engine at no cost to you for diagnosis, parts and labor.

MANUFACTURER'S EMISSION CONTROL SYSTEM WARRANTY COVERAGE

Emission control systems on 1995 and later model year California utility and lawn and garden equipment engines are warranted for two years as hereinafter noted. In other states, 1997 and later model year engines are also warranted for two years. If, during such warranty period, any emission-related part on your engine is defective in materials or workmanship, the part will be repaired or replaced by Sears, Roebuck and Co.

OWNER'S WARRANTY RESPONSIBILITIES

As the utility or lawn and garden equipment engine owner, you are responsible for the performance of the required maintenance listed in your Owner's Manual, but Sears, Roebuck and Co. will not deny warranty solely due to the lack of receipts or for your failure to provide written evidence of the performance of all scheduled maintenance.

As the utility or lawn and garden equipment engine owner, you should, however, be aware that Sears, Roebuck and Co. may deny your warranty coverage if your utility or lawn and garden equipment or a part thereof has failed due to abuse, neglect, improper maintenance or unapproved modifications.

You are responsible for presenting your utility or lawn and garden equipment engine to a Sears, Roebuck and Co. Authorized Service Outlet as soon as a problem exists. The warranty repairs should be completed in a reasonable amount of time, not to exceed 30 days.

Warranty service can be arranged by contacting either a Sears, Roebuck and Co. Authorized Service Outlet, or by contacting Sears, Roebuck and Co. at 1-800-473-7247.

IMPORTANT NOTE

This warranty statement explains your rights and obligations under the Emission Control System Warranty ("ECS Warranty") which is provided to you by Sears, Roebuck and Co. pursuant to California law. See also the Sears, Roebuck and Co. Limited Warranties for Sears, Roebuck and Co. which is enclosed therewith on a separate sheet and also is provided to you by Sears, Roebuck and Co. The ECS Warranty applies only to the emission control system of your new engine. To the extent that there is any conflict in terms between the ECS Warranty and the Sears, Roebuck and Co. Warranty, the ECS Warranty shall apply except in any circumstances in which the Sears, Roebuck and Co. Warranty may provide a longer warranty period. Both the ECS Warranty and the Sears, Roebuck and Co. Warranty describe important rights and obligations with respect to your new engine.

Warranty service can only be performed by a Sears, Roebuck and Co. Authorized Service Outlet. At the time of requesting warranty service, evidence must be presented of the date of sale to the original purchaser. The purchaser shall pay any charges for making service calls and/or for transporting the products to and from the place where the inspection and/or warranty work is performed. The purchaser shall be responsible for any damage or loss incurred in connection with the transportation of any engine or any part(s) thereof submitted for inspection and/or warranty work.

If you have any questions regarding your warranty rights and responsibilities, you should contact Sears, Roebuck and Co. at 1-800-473-7247.

EMISSION CONTROL SYSTEM WARRANTY

Emission Control System Warranty ("ECS Warranty") for 1995 and later model year California utility and lawn and garden equipment engines (for other states, 1997 and later model year engines):

A. **APPLICABILITY:** This warranty shall apply to 1995 and later model year California utility and lawn and garden equipment engines (for other states, 1997 and later model year engines). The ECS Warranty Period shall begin on the date the new engine or equipment is delivered to its original, end-use purchaser, and shall continue for 24 consecutive months thereafter.

B. **GENERAL EMISSIONS WARRANTY COVERAGE:** Sears, Roebuck and Co. warrants to the original, end-use purchaser of the new engine or equipment and to each subsequent purchaser that each of its utility and lawn and garden equipment engines is:

1. Designed, built and equipped so as to conform with all applicable regulations adopted by the Air Resources Board pursuant to its authority in Chapters 1 and 2, Part 5, Division 26 of the Health and Safety Code, and
2. Free from defects in materials and workmanship which, at any time during the ECS Warranty Period, will cause a warranted emissions-related part to fail to be identical in all material respects to the part as described in the engine manufacturer's application for certification.

C. The ECS Warranty only pertains to emissions-related parts on your engine, as follows:

1. Any warranted, emissions-related parts which are not scheduled for replacement as required maintenance in the Owner's Manual shall be warranted for the ECS Warranty Period. If any such part fails during the ECS Warranty Period, it shall be repaired or replaced by Sears, Roebuck and Co. according to Subsection 4 below. Any such part repaired or replaced under the ECS Warranty shall be warranted for any remainder of the ECS Warranty Period.
2. Any warranted, emissions-related part which is scheduled only for regular inspection as specified in the Owner's Manual shall be warranted for the ECS Warranty Period. A statement in such written instructions to the effect of "repair or replace as necessary", shall not reduce the ECS Warranty Period. Any such part repaired or replaced under the ECS Warranty shall be warranted for the remainder of the ECS Warranty Period.
3. Any warranted, emissions-related part which is scheduled for replacement as required maintenance in the Owner's Manual, shall be warranted for the period of time prior to the first scheduled replacement point for that part. If the part fails prior to the first scheduled replacement, the part shall be repaired or replaced by Sears, Roebuck and Co. according to Subsection 4 below. Any such emissions-related part repaired or replaced under the ECS Warranty, shall be warranted for the remainder of the ECS Warranty Period prior to the first scheduled replacement point for such emissions-related part.
4. Repair or replacement of any warranted, emissions-related part under this ECS Warranty shall be performed at no charge to the owner at a Sears, Roebuck and Co. Authorized Service Outlet.
5. The owner shall not be charged for diagnostic labor which leads to the determination that a part covered by the ECS Warranty is in fact defective, provided that such diagnostic work is performed at a Sears, Roebuck and Co. Authorized Service Outlet.
6. Sears, Roebuck and Co. shall be liable for damages to other original engine components or approved modifications proximately caused by a failure under warranty of an emission-related part covered by the ECS Warranty.
7. Throughout the ECS Warranty Period, Sears, Roebuck and Co. shall maintain a supply of warranted emission-related parts sufficient to meet the expected demand for such emission-related parts.
8. Any Sears, Roebuck and Co. authorized and approved emission-related replacement part may be used in the performance of any ECS Warranty maintenance or repair and will be provided without charge to the owner. Such use shall not reduce Sears, Roebuck and Co. ECS Warranty obligations.
9. Unapproved add-on or modified parts may not be used to modify or repair a Sears, Roebuck and Co. engine. Such use voids this ECS Warranty and shall be sufficient grounds for disallowing an ECS Warranty claim. Sears, Roebuck and Co. shall not be liable hereunder for failures of any warranted parts of a Sears, Roebuck and Co. engine caused by the use of such an unapproved add-on or modified part.

EMISSION-RELATED PARTS INCLUDE THE FOLLOWING:

1. Carburetor Assembly and its Internal Components
 - a) Fuel filter
 - b) Carburetor gaskets
 - c) Intake pipe
2. Air Cleaner Assembly
 - a) Air filter element
3. Ignition System, including:
 - a) Spark plug
 - b) Ignition module
 - c) Flywheel assembly
4. Catalytic Muffler (if so equipped)
 - a) Muffler gasket (if so equipped)
 - b) Exhaust manifold (if so equipped)
5. Crankcase Breather Assembly and its Components
 - a) Breather connection tube

7.22.97EPA/CARB

Sears, Roebuck and Co., Hoffman Estates, IL 60179 U.S.A.

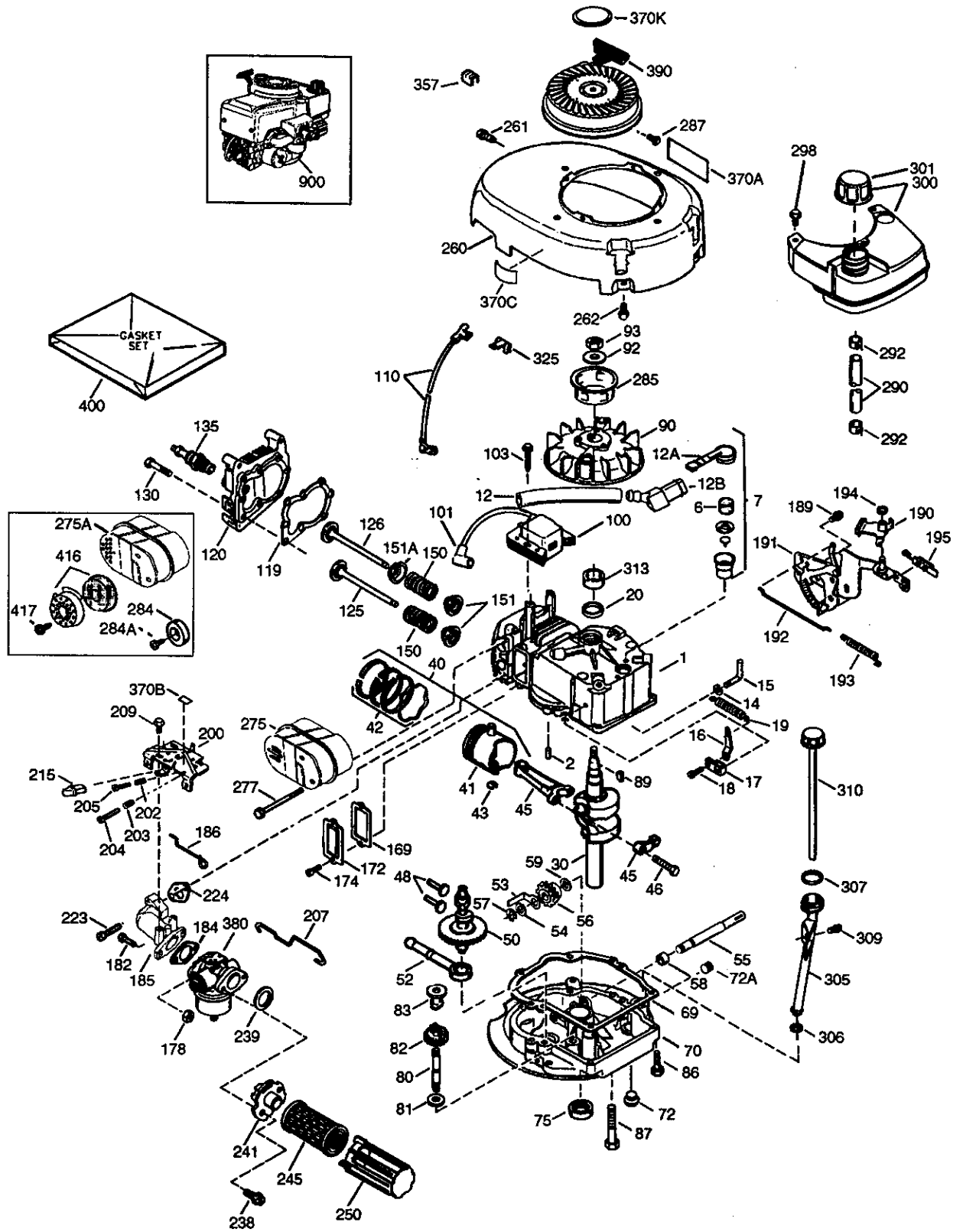

CRAFTSMAN 4-CYCLE ENGINE

MODEL: 143.994012

Ref. No.	Part No.	Part Name	Ref. No.	Part No.	Part Name
1	37280	Cylinder (Incl. 2,20 & 150)	119	*37028	Cylinder Head Gasket
2	26727	Dowel Pin	120	36825	Cylinder Head
6	33734	Breather Element	125	37288	Exhaust Valve (Std.) (Incl. 151)
7	36557	Breather Ass'y. (Incl. 6 & 12A)	126	37289	Intake Valve (Std.) (Incl. 151)
12	36775	Breather Tube	130	6021A	Screw, 5/16-18 x 1-1/2"
12A	36558	Breather Cover & Tube (Incl. 12B)	135	35395	Resistor Spark Plug (RJ19LM)
12B	36694	Breather Tube Elbow	150	31672	Valve Spring
14	28277	Washer	151	31673	Valve Spring Cap
15	31513	Governor Rod (Incl. 14)	151A	40017	Intake Valve Seal
16	34839A	Governor Lever	169	*36783	Valve Cover Gasket
17	31335	Governor Lever Clamp	172	36784	Valve Cover
18	651018	Screw, Torx T-15, 8-32 x 19/64"	174	30200	Screw, 10-24 x 9/16"
19	36281	Extension Spring	178	29752	Nut & Lock Washer, 1/4-28
20	32600	Oil Seal	182	6201	Screw, 1/4-28 x 7/8"
30	37146	Crankshaft	184	*26756	Carburetor To Intake Pipe Gasket
40	35544A	Piston, Pin & Ring Set (Std.)	185	36785	Intake Pipe
40	35545A	Piston, Pin & Ring Set (.010" OS)	186	34337	Governor Link
40	35546	Piston, Pin & Ring Set (.020" OS)	189	650839	Screw, 1/4-20 x 3/8"
41	35541	Piston & Pin Ass'y. (Std.) (Incl. 43)	190	35831	Brake Lever
41	35542	Piston & Pin Ass'y. (.010" OS) (Incl. 43)	191	35015B	S.E. Brake Bracket (Incl. 195)
41	35543	Piston & Pin Ass'y. (.020" OS) (Incl. 43)	192	34966	Brake Control Link
42	35547A	Ring Set (Std.)	193	34695	Brake Spring
42	35548A	Ring Set (.010" OS)	194	32309	Retaining Ring
42	35549	Ring Set (.020" OS)	195	610973	Terminal
43	20381	Piston Pin Retaining Ring	200	35727	Control Bracket (Incl. 202 thru 205)
45	36777	Connecting Rod Ass'y. (Incl. 46)	202	36482	Compression Spring
46	32610A	Connecting Rod Bolt	203	31342	Compression Spring
48	27241	Valve Lifter	204	651029	Screw, Torx T-10, 5-40 x 7/16"
50	37032	Camshaft (NCR)	205	651019	Screw, Torx T-10, 6-32 x 41/64"
52	29914	Oil Pump Ass'y.	207	34336	Throttle Link
53	31745	Tang Washer	209	30200	Screw, 10-24 x 9/16"
54	31747	Washer	215	32410	Control Knob
55	33774	P.T.O. Shaft	223	650451	Screw, 1/4-20 x 1"
56	33401	R.H. Worm Gear	224	*36786	Intake Pipe Gasket
57	31749	Retainer Ring	238	650932	Screw, 10-32 x 49/64"
58	31744	Oil Seal	239	*34338	Air Cleaner Gasket
59	31787	Washer	241	35797	Air Cleaner Collar
69	*35261	Mounting Flange Gasket	245	35066	Air Cleaner Filter
70	33521F	Mounting Flange (Incl. 58, 72 thru 83, 306)	250	35065	Air Cleaner Cover
72	36083	Oil Drain Plug	260	36980	Blower Housing
72A	28534	Oil Drain Plug	261	30200	Screw, 10-24 x 9/16"
75	26208	Oil Seal	262	650831	Screw, 1/4-20 x 1/2"
80	30574A	Governor Shaft	275	36837A	Muffler
81	30590A	Washer	275A	36838A	Spark Arrestor Muffler (Optional) (Incl. 284, 284A, 416, 417)
82	30591	Governor Gear Ass'y. (Incl. 81)	277	650988	Screw, 1/4-20 x 2-5/16"
83	30588A	Governor Spool	284	36663	Muffler Deflector (Incl. 284A) (Optional)
86	650488	Screw, 1/4-20 x 1-1/4"	284A	650821	Screw, 10-32 x 1/2" (Optional)
87	650492	Screw, 1/4-20 x 2-1/4"	285	35000A	Starter Cup
89	611004	Flywheel Key	287	650926	Screw, 8-32 x 21/64"
90	611112	Flywheel	290	29774	Fuel Line
92	650815	Belleville Washer	292	26460	Fuel Line Clamp
93	650816	Flywheel Nut	298	28763	Screw, 10-32 x 35/64"
100	34443B	Solid State Ignition	300	36916	Fuel Tank (Incl. 292 & 301)
101	610118	Spark Plug Cover	301	36246	Fuel Cap
103	651007	Screw, Torx T-15, 10-24 x 15/16"			
110	37047	Ground Wire			

*Indicates Parts Included in Gasket Set, Ref. No. 400.

CRAFTSMAN 4-CYCLE ENGINE

MODEL: 143.994012

Ref. No.	Part No.	Part Name	Ref. No.	Part No.	Part Name
305	35647	Oil Fill Tube	400	37029A	Gasket Set (Incl. Items Marked *)
306	*36996	"O"-Ring	416	36085	Spark Arrestor Kit (Incl. 417)
307	35499	"O"-Ring			(Optional)
309	650562	Screw, 10-32 x 3/8"	417	650821	Screw, 10-32 x 1/2" (Optional)
310	35648	Dipstick	900		Replacement Engine 750825A, order from 71-999
313	34080	Spacer	900		Replacement Short Block NONE
325	37152	Spring Clip		181-1186-11	Operator's Manual
357	36412	Starter Rope Retainer			
370A	36261	Lubrication Decal			
370B	35167	Control Decal			*Indicates Parts Included in Gasket Set, Ref. No. 400.
370C	37199	Primer Decal			
370K	36695	Starter Decal			
380	640156	Carburetor (Incl. 184)			RPM High 2700 to 3000
390	590737	Rewind Starter (NOTE: This engine could have been built with 590694 starter).			RPM Low 2400 to 2700

CARBURETOR NO. 640156

Ref. No.	Part No.	Part Name
	640156	Carburetor (Incl. 184 of Engine Parts List)
1	631615	Throttle Shaft & Lever Assembly
2	631767	Throttle Return Spring
4	*631184	Dust Seal Washer
5	*631183	Dust Seal (Throttle)
6	640070	Throttle Shutter
7	*650506	Shutter Screw
16	631807	Fuel Fitting
17	651025	Throttle Crack Screw/Idle Speed Screw
18	630766	Tension Spring
20	640016	Idle Restrictor Screw
20A	640053	Idle Restrictor Screw Cap
25	631867	Float Bowl
27	*631024	Float Shaft
28	632019	Float
29	*631028	Float Bowl "O" Ring
30	*631021	Inlet Needle, Seat, & Clip (Incl. 31)
31	631022	Spring Clip
35	36045A	Primer Bulb/Retainer Ring
36	632735	Main Nozzle Tube
36A	632766	Carburetor Tube
37	*632547	"O" Ring, Main Nozzle Tube
40	640157	High Speed Bowl Nut
44	27110A	Bowl Nut Washer
47	*630748	Welch Plug, Idle Mixture Well
48	(631027	Welch Plug, Atmospheric Vent
60	632760	Repair kit (Incl. Items Marked *)

REWIND STARTER NO. 590737

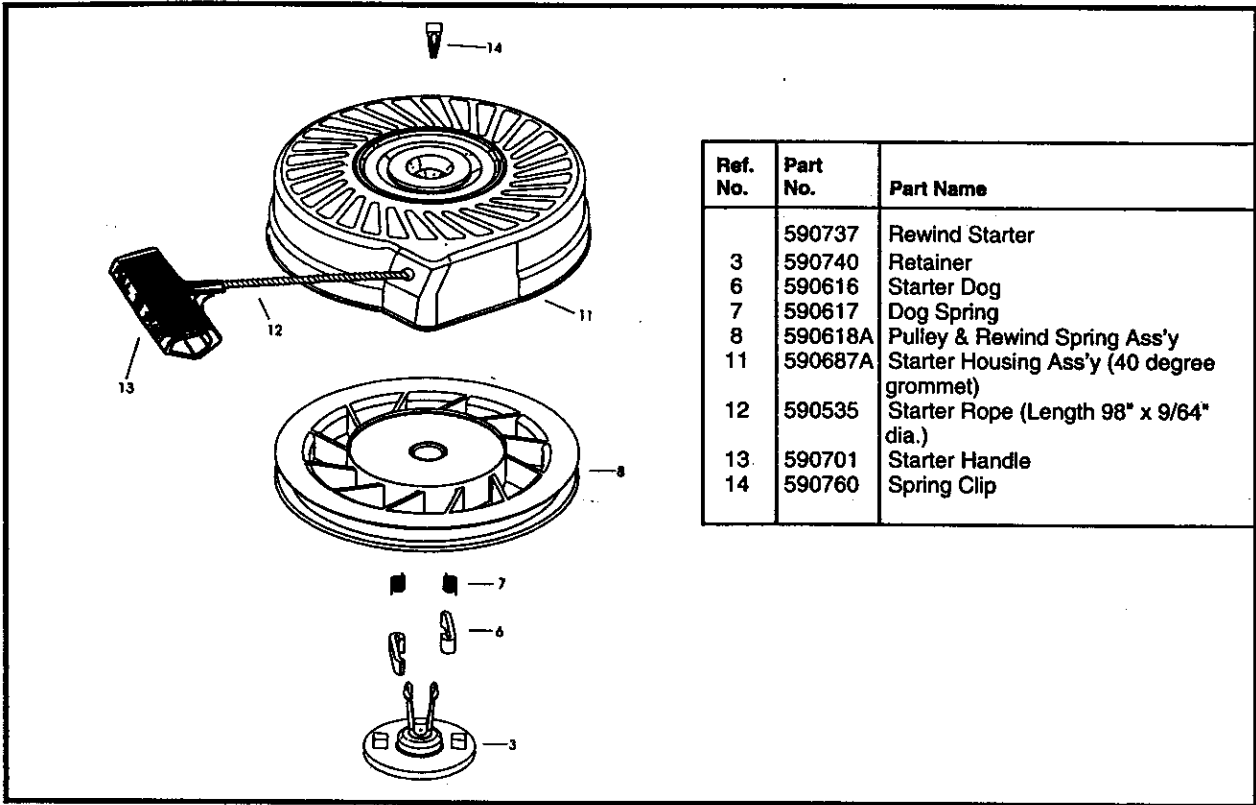

Ref. No.	Part No.	Part Name
	590737	Rewind Starter
3	590740	Retainer
6	590616	Starter Dog
7	590617	Dog Spring
8	590618A	Pulley & Rewind Spring Ass'y
11	590687A	Starter Housing Ass'y (40 degree grommet)
12	590535	Starter Rope (Length 98" x 9/64" dia.)
13	590701	Starter Handle
14	590760	Spring Clip

STARTER NO. 590694

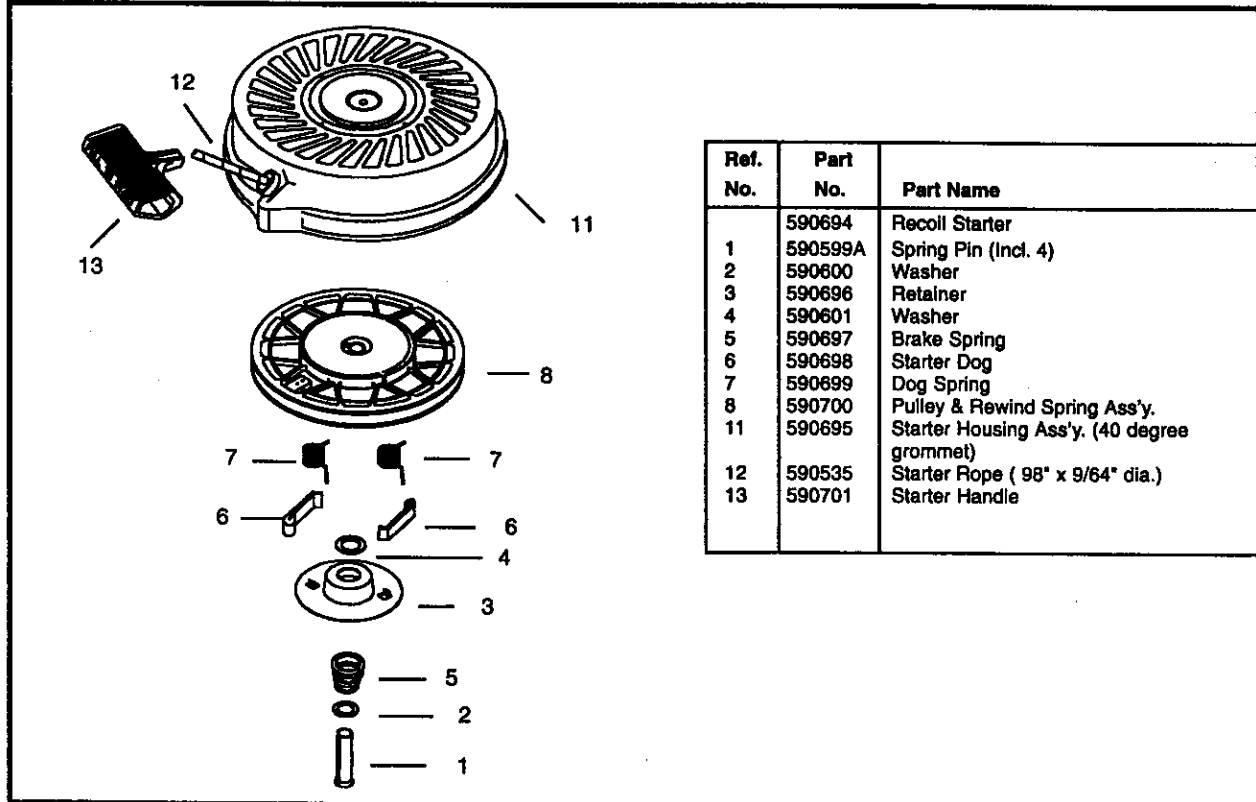

Ref. No.	Part No.	Part Name
	590694	Recoil Starter
1	590599A	Spring Pin (Incl. 4)
2	590600	Washer
3	590696	Retainer
4	590601	Washer
5	590697	Brake Spring
6	590698	Starter Dog
7	590699	Dog Spring
8	590700	Pulley & Rewind Spring Ass'y.
11	590695	Starter Housing Ass'y. (40 degree grommet)
12	590535	Starter Rope (98" x 9/64" dia.)
13	590701	Starter Handle

SEARS

operator's manual

MODEL NO. 143.994012

**4.0 RESERVE POWER
10 CUBIC INCH (163 cc)
DISPLACEMENT**

SOLID STATE IGNITION

CAUTION:

Read **RULES** for
Safe **OPERATION**
and **INSTRUCTIONS**
Carefully

How to ORDER Repair Parts

The Model Number can be found on a decal on the blower housing (See Figure 1). Always mention the Model Number when requesting service or repair parts for your Craftsman Engine.

All parts listed herein may be ordered from any SEARS, ROEBUCK AND CO. or SEARS CANADA, INC. retail or catalog store. If the parts you need are not stocked locally, your order will be electronically transmitted to a Sears Repair Parts Distribution Center for expedited handling.

WHEN ORDERING REPAIR PARTS, ALWAYS GIVE THE FOLLOWING INFORMATION AS SHOWN IN THIS LIST.

1. The **PART NUMBER**
2. The **PART DESCRIPTION**
3. The **MODEL NUMBER**
4. The **NAME OF ITEM - ENGINE**

"Your Sears merchandise has added value when you consider that Sears has service units nationwide staffed with Sears trained technicians... professional technicians specifically trained on Sears products, having the parts, tools and equipment to insure that we meet our pledge to you ... we service what we sell."

**Sold by SEARS, ROEBUCK AND CO., CHICAGO, IL 60684 U.S.A.
and SEARS CANADA, INC., TORONTO, ONTARIO, CANADA**
