

Owner's Manual

CRAFTSMAN®

11 in. variable speed **BAND SAW**

Model No.
315.214500

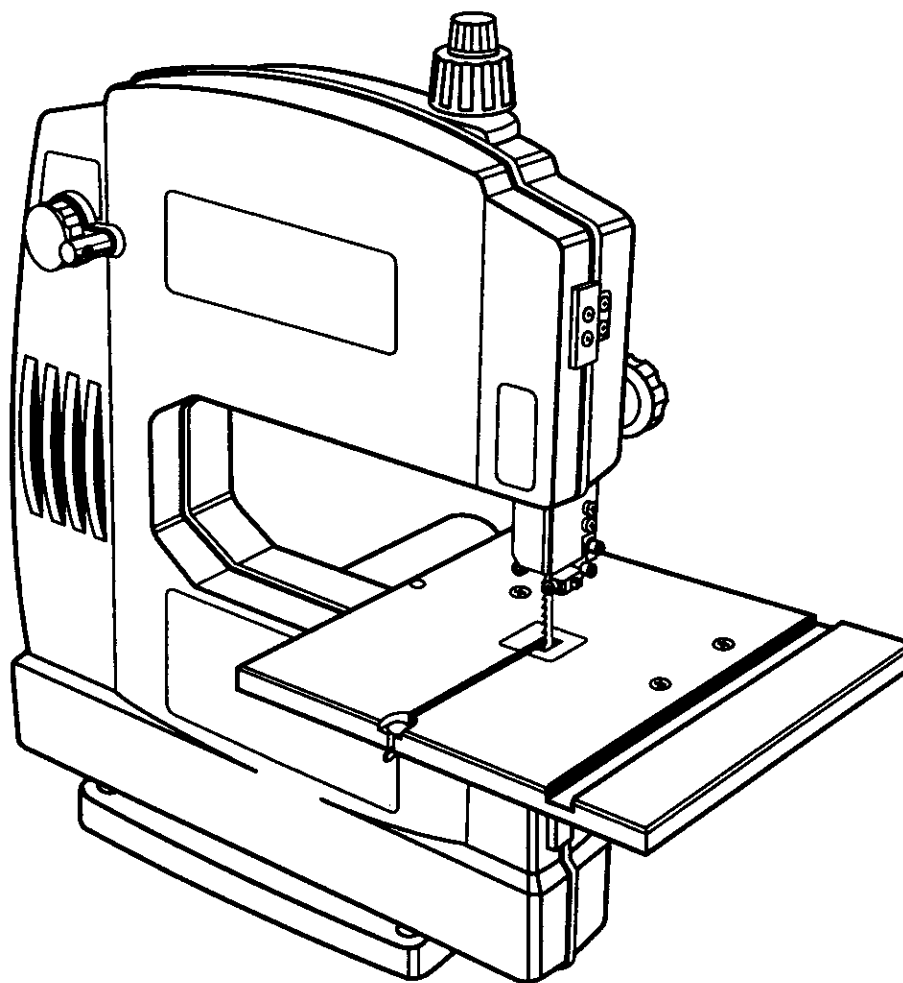

Save this manual for
future reference.

⚠ CAUTION: Read and
follow all Safety Rules and
Operating Instructions before
first use of this product.

Customer Help Line
1-800-932-3188

Sears, Roebuck and Co., Hoffman Estates, IL 60179 USA
Visit the Craftsman web page: www.sears.com/craftsman

972000-510
6-98

- SAFETY
- FEATURES
- ADJUSTMENTS
- OPERATION
- MAINTENANCE
- PARTS LIST



TABLE OF CONTENTS

■ Table of Contents	2
■ Warranty and Introduction	2
■ Rules For Safe Operation	3-5
■ Electrical	6
■ Glossary and Product Specifications	7
■ Unpacking, Loose Parts List, and Tools Needed	8
■ Labels	9-10
■ Features	11
■ Assembly	12-13
■ Adjustments	13-18
■ Basic Operation	18-21
■ Maintenance	21-23
■ Troubleshooting	24
■ Exploded View and Repair Parts List	26-33
■ Parts Ordering / Service	34

WARRANTY

FULL ONE YEAR WARRANTY ON CRAFTSMAN BAND SAW

If this **CRAFTSMAN**® Band Saw fails due to a defect in material or workmanship within one year from the date of purchase, Sears will repair it, free of charge.

Contact a Sears Service Center for repair.

If this product is used for commercial or rental purposes, this warranty applies only for 90 days from the date of purchase.

This warranty gives you specific legal rights, and you may also have other rights which vary from state to state.

Sears, Roebuck and Co., Dept. 817WA, Hoffman Estates, IL 60179

INTRODUCTION

Your saw has many features for making cutting operations more pleasant and enjoyable. Safety, performance and dependability have been given top priority in the design of this saw making it easy to maintain and operate.

⚠ CAUTION: Carefully read through this entire owner's manual before using your new saw. Pay close attention to the Rules For Safe Operation, and all Safety Alert Symbols including Danger, Warning and Caution. If you use your saw properly and only for what it is intended, you will enjoy years of safe, reliable service.

⚠ Look for this symbol to point out important safety precautions. It means attention!!!
Your safety is involved.

⚠ WARNING:



The operation of any power tool can result in foreign objects being thrown into your eyes, which can result in severe eye damage. Before beginning power tool operation, always wear safety goggles or safety glasses with side shields and a full face shield when needed. We recommend Wide Vision Safety Mask for use over eyeglasses or standard safety glasses with side shields, available at Sears Retail Stores.

RULES FOR SAFE OPERATION

The purpose of safety symbols is to attract your attention to possible dangers. The safety symbols, and the explanations with them, deserve your careful attention and understanding. The safety warnings do not by themselves eliminate any danger. The instructions or warnings they give are not substitutes for proper accident prevention measures.

SYMBOL MEANING



SAFETY ALERT SYMBOL:

Indicates danger, warning or caution. May be used in conjunction with other symbols or pictographs.



DANGER: Failure to obey a safety warning will result in serious injury to yourself or to others. Always follow the safety precautions to reduce the risk of fire, electric shock and personal injury.



WARNING: Failure to obey a safety warning can result in serious injury to yourself or to others. Always follow the safety precautions to reduce the risk of fire, electric shock and personal injury.



CAUTION: Failure to obey a safety warning may result in property damage or personal injury to yourself or to others. Always follow the safety precautions to reduce the risk of fire, electric shock and personal injury.

Note: Advises you of information or instructions vital to the operation or maintenance of the equipment.

IMPORTANT

Servicing requires extreme care and knowledge of the system and should be performed only by a qualified service technician. For service we suggest you return the tool to your nearest Sears store for repair. Always use original factory replacement parts when servicing.

WARNING: Do not attempt to operate this tool until you have read thoroughly and understand completely all instructions, safety rules, etc. contained in this manual. Failure to comply can result in accidents involving fire, electric shock, or serious personal injury. Save owner's manual and review frequently for continuing safe operation, and instructing others who may use this tool.

READ ALL INSTRUCTIONS

- **KNOW YOUR POWER TOOL.** Read the owner's manual carefully. Learn the saw's applications and limitations as well as the specific potential hazards related to this tool.
- **GUARD AGAINST ELECTRICAL SHOCK BY PREVENTING BODY CONTACT WITH GROUNDED SURFACES.** For example; pipes, radiators, ranges, refrigerator enclosures.
- **KEEP GUARDS IN PLACE** and in good working order.
- **REMOVE ADJUSTING KEYS AND WRENCHES.** Get in the habit of checking to see that hex keys and adjusting wrenches are removed from tool before turning it on.

- **KEEP THE WORK AREA CLEAN.** Cluttered work areas and work benches invite accidents. **DO NOT** leave tools or pieces of wood on the saw while it is in operation.
- **DO NOT USE IN DANGEROUS ENVIRONMENT.** Do not use power tools near gasoline or other flammable liquids, in damp or wet locations, or expose them to rain. Keep the work area well lit.
- **KEEP CHILDREN AND VISITORS AWAY.** All visitors should wear safety glasses and be kept a safe distance from work area. Do not let visitors contact tool or extension cord while operating.
- **MAKE WORKSHOP CHILD-PROOF** with padlocks and master switches or by removing starter keys.
- **DO NOT FORCE THE TOOL.** It will do the job better and safer at the rate for which it was designed.
- **USE THE RIGHT TOOL.** Do not force the tool or attachment to do a job it was not designed for. Don't use it for a purpose not intended.
- **USE THE PROPER EXTENSION CORD.** Make sure your extension cord is in good condition.

RULES FOR SAFE OPERATION (Continued)

When using an extension cord, be sure to use one heavy enough to carry the current your product will draw. An undersized cord will cause a drop in line voltage resulting in loss of power and overheating. A wire gage size (A.W.G.) of at least **18** is recommended for an extension cord 25 feet or less in length. If in doubt, use the next heavier gage. The smaller the gage number, the heavier the cord.

- **INSPECT EXTENSION CORDS PERIODICALLY** and replace if damaged.
- **DRESS PROPERLY.** Do not wear loose clothing, gloves, neckties, rings, bracelets, or other jewelry. They can get caught and draw you into moving parts. Rubber gloves and nonslip footwear are recommended. Also wear protective hair covering to contain long hair.
- **ALWAYS WEAR SAFETY GLASSES WITH SIDE SHIELDS.** Everyday eyeglasses have only impact-resistant lenses; they are **NOT** safety glasses.
- **PROTECT YOUR LUNGS.** Wear a face or dust mask if the cutting operation is dusty.
- **PROTECT YOUR HEARING.** Wear hearing protection during extended periods of operation.
- **SECURE WORK.** Use clamps or a vise to hold work when practical. It's safer than using your hand and it frees both hands to operate tool.
- **DO NOT OVERREACH.** Keep proper footing and balance at all times.
- **MAINTAIN TOOLS WITH CARE.** Keep tools sharp and clean for better and safer performance. Follow instructions for lubricating and changing accessories.
- **DISCONNECT ALL TOOLS.** When not in use, before servicing, or when changing attachments, blades, bits, cutters, etc., all tools should be disconnected from power supply.
- **AVOID ACCIDENTAL STARTING.** Be sure switch is off when plugging in.
- **USE RECOMMENDED ACCESSORIES.** The use of improper accessories may cause risk of injury.
- **NEVER STAND ON TOOL.** Serious injury could occur if the tool is tipped or if the blade is unintentionally contacted.
- **CHECK DAMAGED PARTS.** Before further use of the tool, a guard or other part that is damaged should be carefully checked to determine that it will operate properly and perform its intended function. Check for alignment of moving parts,

binding of moving parts, breakage of parts, saw stability, mounting and any other conditions that may affect its operation. A guard or other part that is damaged must be properly repaired or replaced by a qualified service technician at a Sears store to avoid risk of personal injury.

- **DIRECTION OF FEED.** Feed work into a blade or cutter against the direction of rotation of the blade or cutter only.
 - **NEVER LEAVE TOOL RUNNING UNATTENDED. TURN THE POWER OFF.** Do not leave tool until it comes to a complete stop.
 - **USE ONLY CORRECT BLADES.** Use the right blade size, style and cutting speed for the material and the type of cut. Blade teeth should point down toward the table.
 - **KEEP BLADES CLEAN, SHARP AND WITH SUFFICIENT SET.** Sharp blades minimize stalling and kickback.
 - **DO NOT REMOVE THE SAW'S BLADE GUARDS.** Never operate the saw with any guard or cover removed. Make sure all guards are operating properly before each use.
 - **KEEP HANDS AWAY FROM CUTTING AREA.** Do not hand hold pieces so small that your fingers go under the blade guard. Do not reach underneath work or in blade cutting path with your hands and fingers for any reason.
-  **WARNING:** Blade coasts after turn off.
- **DO NOT ABUSE CORD.** Never yank cord to disconnect it from receptacle. Keep cord from heat, oil, and sharp edges.
 - **INSPECT TOOL CORDS PERIODICALLY** and if damaged, have repaired by a qualified service technician at a Sears store. Stay constantly aware of cord location and keep it well away from the moving blade.
 - **DO NOT USE TOOL IF SWITCH DOES NOT TURN IT ON AND OFF.** Have defective switches replaced by a qualified service technician at a Sears store.
 - **KEEP TOOL DRY, CLEAN, AND FREE FROM OIL AND GREASE.** Always use a clean cloth when cleaning. Never use brake fluids, gasoline, petroleum-based products, or any solvents to clean tool.
 - **ALWAYS SUPPORT LARGE WORKPIECES** while cutting. To minimize risk of blade pinching and kickback, always support large workpieces. Saw may slip, walk or slide while cutting large or heavy boards.

RULES FOR SAFE OPERATION (Continued)

- **BEFORE MAKING A CUT, BE SURE ALL ADJUSTMENTS ARE SECURE.**
- **BEFORE CHANGING THE SETUP, REMOVING COVERS, GUARDS OR BLADE, TURN OFF THE SAW, AND UNPLUG THE SAW.**
- **DO NOT FEED THE MATERIAL TOO QUICKLY.** Do not force the workpiece against the blade.
- **NEVER** cut more than one piece at a time. **DO NOT STACK** more than one workpiece on the saw table at a time.
- **AVOID CUTTING NAILS.** Inspect for and remove all nails from lumber before cutting.
- **NEVER TOUCH BLADE** or other moving parts during use.
- **NEVER START A TOOL WHEN THE BLADE IS IN CONTACT WITH THE WORKPIECE.**
- **ALLOW THE MOTOR TO COME UP TO FULL SPEED** before starting a cut.
- **FIRMLY CLAMP OR BOLT** your band saw to a firm, level workbench or table. The most comfortable saw table height is 36 inches or at approximately hip height.
- **AVOID AWKWARD OPERATIONS AND HAND POSITIONS** where a sudden slip could cause your hand to move into the blade. **ALWAYS** make sure you have good balance.
- **REPLACEMENT PARTS.** All repairs, whether electrical or mechanical, should be made by a qualified service technician at a Sears store.
- ▲ **WARNING:** When servicing, use only identical Craftsman replacement parts. Use of any other parts may create a hazard or cause product damage.
- **NEVER USE IN AN EXPLOSIVE ATMOSPHERE.** Normal sparking of the motor could ignite fumes.
- **DO NOT OPERATE THIS TOOL WHILE UNDER THE INFLUENCE OF DRUGS, ALCOHOL, OR ANY MEDICATION.**
- **STAY ALERT AND EXERCISE CONTROL.** Watch what you are doing and use common sense. **Do not operate tool when you are tired. Do not rush.**
- **MAKE SURE THE WORK AREA HAS AMPLE LIGHTING** to see the work and that no obstructions will interfere with safe operation **BEFORE** performing any work using your saw.
- **ALWAYS TURN OFF SAW** before disconnecting it, to avoid accidental starting when reconnecting to power supply. **NEVER** leave the band saw unattended while connected to a power source.
- **SAVE THESE INSTRUCTIONS.** Refer to them frequently and use to instruct other users. If you loan someone this tool, loan them these instructions also.

SAVE THESE INSTRUCTIONS

ATTENTION:

The blade guides and thrust bearings have been pre-assembled but will require final adjustment before using your saw. Refer to “**ADJUSTING THRUST BEARINGS, BLADE GUIDE SUPPORT, AND BLADE GUIDES**” procedures explained in the **ADJUSTMENTS** section of the owner’s manual.

EXTENSION CORDS

Use only 3-wire extension cords that have 3-prong grounding plugs and 3-pole receptacles that accept the tool's plug. When using a power tool at a considerable distance from the power source, use an extension cord heavy enough to carry the current that the tool will draw. An undersized extension cord will cause a drop in line voltage, resulting in a loss of power and causing the motor to overheat. Use the chart provided below to determine the minimum wire size required in an extension cord. Only round jacketed cords listed by Underwriter's Laboratories (UL) should be used.

Length of Extension Cord	Wire Size (A.W.G.)
Up to 25 feet	18
26-100 feet	16

When working with the tool outdoors, use an extension cord that is designed for outside use. This is indicated by the letters **WA** on the cord's jacket.

Before using an extension cord, inspect it for loose or exposed wires and cut or worn insulation.

CAUTION: Keep the cord away from the cutting area and position the cord so that it will not be caught on lumber, tools, or other objects during cutting.

ELECTRICAL CONNECTION

Your Sears Craftsman Band Saw is powered by a precision built electric motor. It should be connected to a power supply that is 120 volts, 60 Hz, AC only (normal household current). Do not operate this tool on direct current (DC). A substantial voltage drop will cause a loss of power and the motor will overheat. If the saw does not operate when plugged into an outlet, double check the power supply.

GROUNDING INSTRUCTIONS

In the event of a malfunction or breakdown, grounding provides a path of least resistance for electric current to reduce the risk of electric shock. This tool is equipped with an electric cord having an equipment-grounding conductor and a grounding plug. The plug must be plugged into a matching outlet that is properly installed and grounded in accordance with all local codes and ordinances.

Do not modify the plug provided. If it will not fit the outlet, have the proper outlet installed by a qualified electrician. Improper connection of the equipment-grounding conductor can result in a risk of electric shock. The conductor with insulation having an outer surface that is green with or without yellow stripes is the equipment-grounding conductor. If repair or replacement of the electric cord or plug is necessary, do not connect the equipment-grounding conductor to a live terminal.

Check with a qualified electrician or service personnel if the grounding instructions are not completely understood, or if in doubt as to whether the tool is properly grounded.

Repair or replace a damaged or worn cord immediately.

This tool is intended for use on a circuit that has an outlet like the one shown in *Figure 1*. It also has a grounding pin like the one shown.

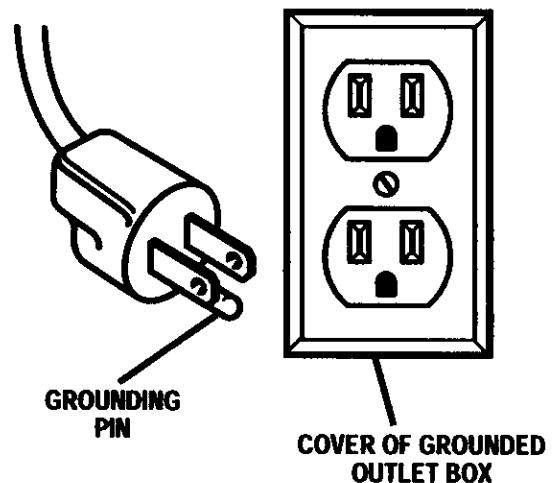

Fig. 1

GLOSSARY OF TERMS FOR WOODWORKING

Bevel Cut

A cutting operation made with an angled table.

Crosscut

A cutting operation made across the grain or the width of the workpiece.

Compound Cut

A compound cut is a cut made using a miter angle and a bevel angle at the same time.

FPM

Feet per minute. Used in reference to surface speed of blade.

Ferrous Metal

Metal that contains iron; such as steel.

Freehand (for band saw)

Performing a cut without the workpiece properly supported on the table.

Gum

A sticky, sap based residue from wood products.

Kerf

The material removed by the blade in a through cut or the slot produced by the blade in a nonthrough or partial cut.

Leading End

The end of the workpiece pushed into the cutting tool first.

Nonferrous Metal

Metal that does not contain iron; such as aluminum, brass, and copper.

Miter Cut

A cutting operation made with the edge of the workpiece at any angle to the blade other than 90 degrees.

Push Stick

A device used to feed the workpiece through the saw blade during narrow cutting operations. It helps keep the operator's hands well away from the blade.

Resaw

A cutting operation to reduce the thickness of the workpiece to make thinner pieces.

Resin

A sticky, sap based substance.

Ripping

A cutting operation along the length of the workpiece.

Saw Blade Path

The area directly in line — over, under, behind, or in front of the blade. As it applies to the workpiece, that area which will be, or has been, cut by the blade.

Set

The distance that the tip of the saw blade tooth is bent (or set) outward from the face of the blade.

Throw-Back

Throwing of a workpiece in a manner similar to a kickback. Usually associated with a cause other than the kerf closing, such as a workpiece being dropped into the blade, or being carelessly placed in contact with the blade.

Through Sawing

Any cutting operation where the blade extends completely through the workpiece.

Workpiece

The item on which the cutting operation is being done. The surfaces of a workpiece are commonly referred to as faces, ends, and edges.

Worktable

The surface on which the workpiece rests while performing a cutting operation.

PRODUCT SPECIFICATIONS

Blade Width	1/8 in. to 3/8 in.	Table Tilt	0° - 45°
Blade Length	56-7/8 in.	Input	120 V, 4.2 amp 60 Hz, AC only
Capacities:		No Load Speed	300-3000 FPM
Frame to Blade	11 in.	Overall Dimensions	24-1/2 in. x 12-1/2 in. x 24-1/2 in.
Under guide	3-1/8 in.	Net Weight	28 lbs.
Table Size	11-1/2 in. x 11-1/2 in.		

UNPACKING

⚠ WARNING: To prevent accidental starting that could cause possible serious personal injury, assemble all parts to your saw before connecting it to power supply. Saw should never be connected to power supply when you are assembling parts, making adjustments, installing or removing blades, or when not in use.

■ Carefully remove all parts from the carton and place the saw on a level work surface. Separate and check against the list of loose parts.

⚠ WARNING: If any parts are missing, do not operate this tool until the missing parts are replaced. Failure to do so could result in possible serious personal injury.

■ Do not discard the packing materials until you have carefully inspected the saw, identified all parts, and satisfactorily operated your new saw.

Note: If any parts are damaged or missing, do not attempt to plug in the power cord and turn the switch on until the damaged or missing parts are obtained and are installed correctly.

LOOSE PARTS LIST

Check all loose parts from the box with the list below. For your convenience when identifying parts, items A-H below have been drawn actual size. Assemble according to the instructions on the following pages.

- A. Flat Head Screw (1/4-20 x 7/8 in.) 3
- B. Hex Nut (1/4-20) 3
- C. Wing Nut (1/4-20) 1
- D. Truss Head Screw (1/4-20 x 5/8 in.) 1
- E. Screw (M5 x 8) 1
- F. Scale Indicator 1
- G. Throat Plate 1
- H. Hex Key (1/8 in.) 1
- I. Saw Table (not shown) 1
- J. Owner's Manual (not shown) 1

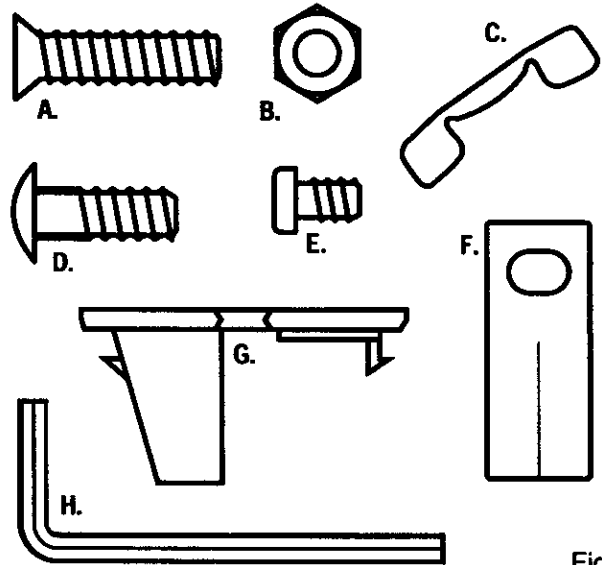

Fig. 2

TOOLS NEEDED

The following tools (not included) are needed for assembly and alignment:

- #2 Phillips Screwdriver
- Adjustable Wrench
- Small Combination Square
- 5/16 in. Socket or Nut Driver

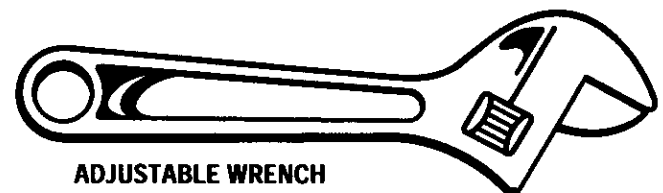
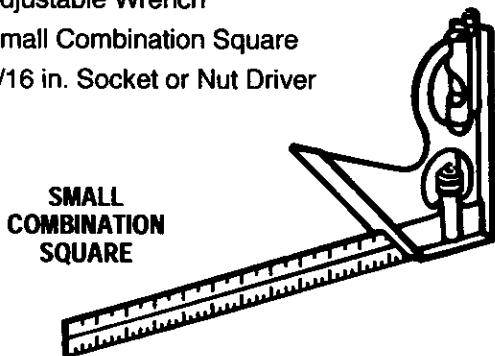

Fig. 3

LABELS

CRAFTSMAN

11-in. Band Saw

3-wheel

1/3-HP

(max. developed)

⚠ WARNING / ADVERTENCIA

- For your safety, read owner's manual before operating saw.
- Wear eye protection.
- Do not remove cutoff pieces until blade has stopped.
- Maintain proper adjustment of blade tension, blade guides, and thrust bearings.
- Adjust upper guide to clear workpiece.
- Hold workpiece firmly against table.
- Do not expose to rain or use in damp places.
- Para su seguridad, lea el manual del usuario antes de usar la sierra.

⚠ WARNING ADVERTENCIA

Keep Hands Away From Blade.
Allow Tool To Stop Before Adjusting Blade Guide.

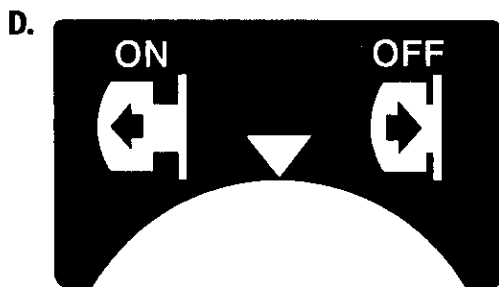

E.
Select The Right Blade For The Job.

Blade Circumference	Blade Width	Blade Thickness	TPI	Application
56 7/8 in.	1/8 in.	.12 in.	15	For fine scroll cuts in thin wood materials and plastics up to 1/2" thick.
56 7/8 in.	1/4 in.	.12 in.	4	For extra fast straight cutting. Best for cutting thick woods.
56 7/8 in.	1/4 in.	.12 in.	6	For straight and curved cuts in solid woods.
56 7/8 in.	3/8 in.	.12 in.	15	For straight and curved cuts in thin materials-wood, plywood, veneer, and plastic.
56 7/8 in.	1/4 in.	.12 in.	14	For non-ferrous metal cutting.

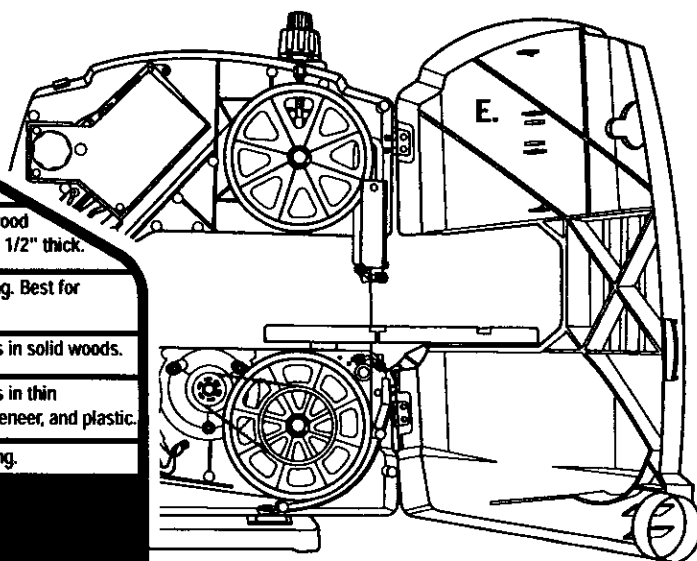
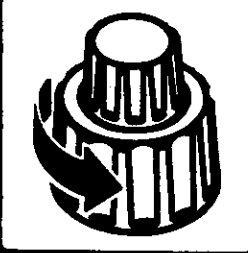

Fig. 4

LABELS

The following labels are on the band saw with locations indicated.

BLADE TENSION ADJUSTMENT



TO RELEASE BLADE TENSION
Rotate the Quick Release Knob 1/4 turn counter-clockwise.

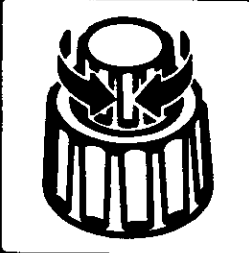

TO ADJUST BLADE TENSION
Turn the Adjustment Knob clockwise to increase tension. Turn counter-clockwise to decrease tension.

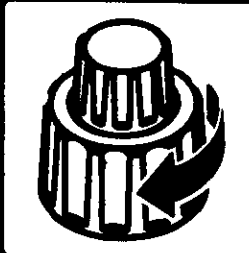

TO ENGAGE BLADE TENSION
Rotate the Quick Release Knob 1/4 turn clockwise before operating band saw.



BLADE TRACKING
Insert Hex Key in tracking adjustment hole. Adjust Hex Key while rotating upper wheel by hand until blade tracks properly on wheels.

⚠ WARNING / ADVERTENCIA

- For your safety, read owner's manual before making adjustments.
- Failure to unplug your saw could result in accidental starting causing possible serious personal injury.
- Para su seguridad, lea el manual del usuario antes de hacer ajustes.

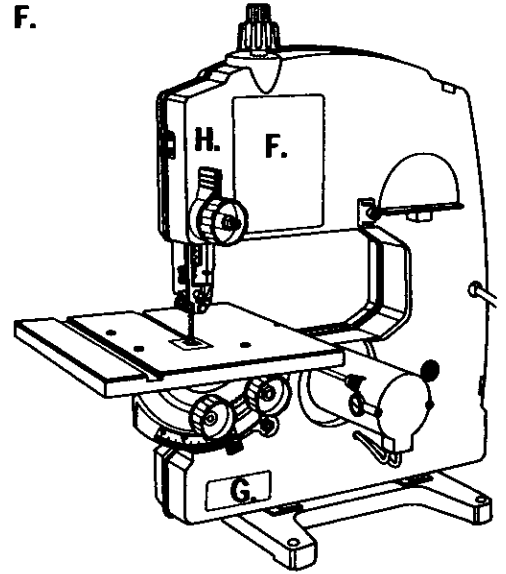

F.

11 inch Band Saw

CUTS ALL TYPES OF WOODS WITH AROUND 1/2 IN.

WARNING: USE IDENTICAL REPLACEMENT PARTS

MODEL 315 214500

MADE IN CHINA

LEANS, BUEHLER AND CO.



Customer Help Line 1-800-932-3188

G.

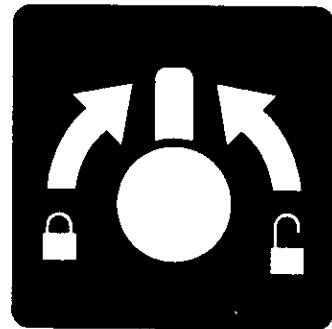

H.

Fig. 5

FEATURES

KNOW YOUR BAND SAW

Before attempting to use, familiarize yourself with all operating features and safety requirements of your Sears Craftsman band saw. See Figure 6.

BLADE

The saw comes with a standard 1/4 in. blade installed.

BLADE GUIDES

Blade guides support the blade and keep it from twisting during operation. An adjustment is necessary when blades are changed or replaced.

BLADE GUIDE KNOB AND LOCK LEVER

The blade guide assembly should just clear the workpiece while cutting. Use the blade guide knob and lock lever to adjust the blade guide assembly to keep the blade from twisting or breaking. Always lock the upper blade guide assembly in place before turning on the band saw.

TABLE LOCK KNOB

Loosening table lock knob allows table to be tilted at different angles. Tightening knob locks table in place.

ANGLE ADJUSTMENT KNOB

Once the table lock knob has been loosened, use the angle adjustment knob to tilt or change the angle of the table. Always tighten the table lock knob before turning on the saw.

SCALE

The scale shows the angle or degree the table is tilted for bevel cutting.

TENSION ADJUSTMENT KNOB

The tension adjustment knob controls the amount of blade tension when changing blades and when making adjustments for various sawing applications.

TRACKING ADJUSTMENT SCREW

Tracking adjustment screw adjusts to keep the blade running in the center of the wheels. It is a set screw located in the center of the frame on the back of your band saw.

BAND SAW TABLE

Your band saw has an 11-1/2 in. square, aluminum saw table with a rack and pinion tilt control for maximum accuracy. It has a red snap in throat plate, and a miter slot for use with an optional miter gage.

SAWDUST EXHAUST PORT

A standard 2-1/4 in. dust exhaust port has been provided to make dustless cutting possible. The pickup adapter end of a vacuum hose fits inside the dust exhaust port with a wedge fit type connection.

COVER TABS

Easy open cover tabs allow the front cover to be opened for making adjustments. See Figure 13.

HEX KEY HOLDER

A hex key holder inside the front cover keeps hex key conveniently located for blade guide and blade tracking adjustments.

ON/OFF KNOB

Your band saw has an easy access On/Off knob with variable speed. Pull the knob out to turn **ON** the saw, and push the knob in to turn **OFF** the saw. Turn the knob to adjust the speed. Place a pad lock in the lock post next to the knob to lock the saw in the **OFF** position.

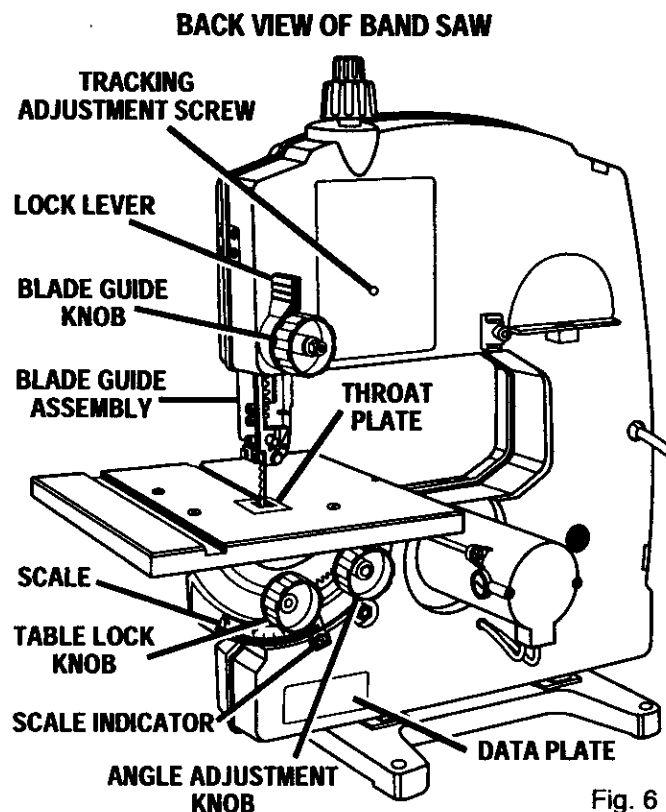
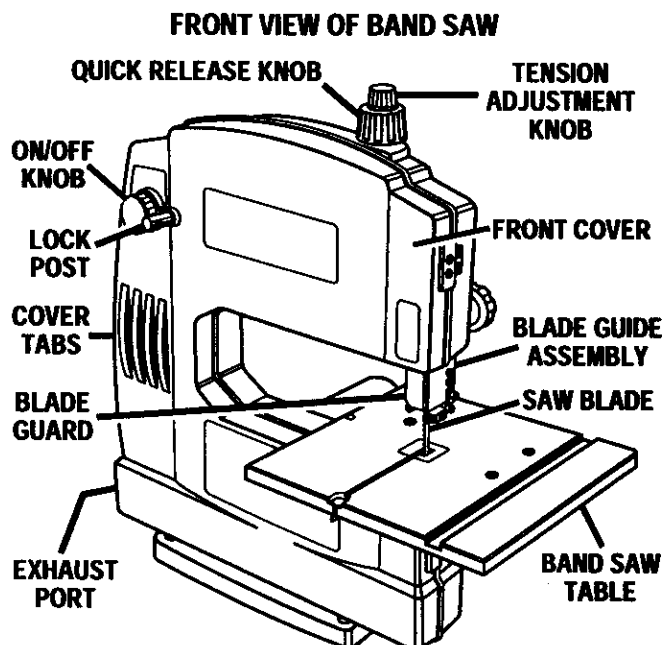

Fig. 6

ASSEMBLY

INSTALLING SCALE INDICATOR

See Figure 7.

- Attach the bevel scale indicator to the saw frame below the scale using the screw supplied.

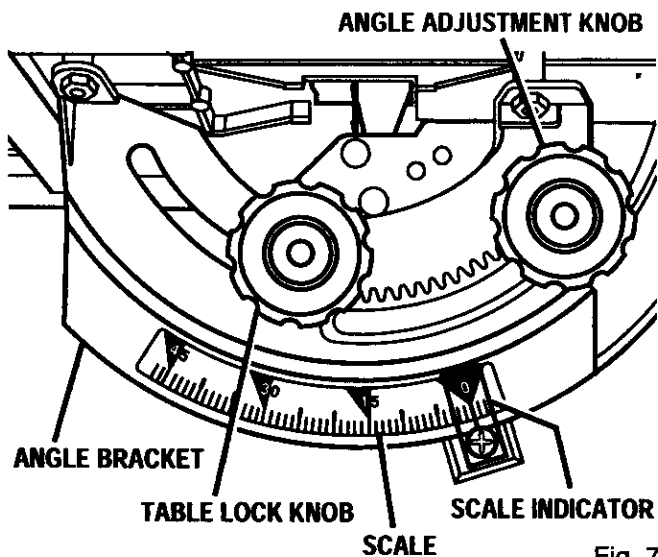

Fig. 7

INSTALLING THE TABLE

See Figure 8.

- Slide the table onto the angle bracket from the back of the saw to front, with the blade traveling through the slot in the table.

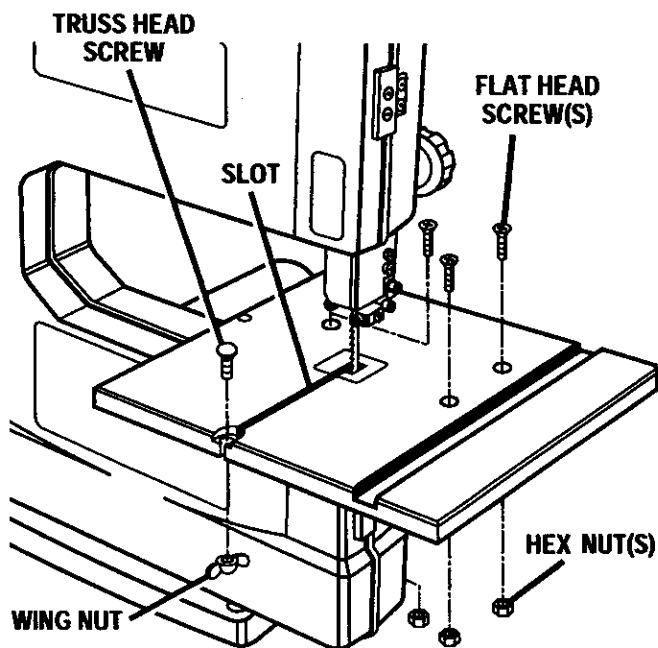

Fig. 8

- Align the three holes on the table with the three holes in the angle bracket. Fasten the table to the angle bracket using the three flat head screws and three hex nuts.

- Assemble the truss head screw and wing nut to the edge of the table at the end of the slot. Snap the throat plate in place on the table.

Note: The wing nut goes below the table.

MOUNTING BAND SAW TO WORKBENCH

See Figure 9.

If the band saw is to be used in a permanent application, we recommend that you secure it in a permanent location such as a workbench. When mounting the saw to a workbench, holes should be drilled through the supporting surface of the workbench using dimensions illustrated.

- Each leg should be bolted securely using 5/16 in. diameter machine screws, lock washers, and 5/16 in. hex nuts (not included). Screw length should be 1-3/4 in. plus the thickness of the bench top.
- Locate and mark the holes where band saw is to be mounted.
- Drill (4) 3/8 in. diameter holes through workbench.
- Place band saw on workbench aligning holes in the frame with holes drilled in the workbench.
- Insert all four 5/16 in. screws and tighten securely with lock washers and hex nuts.

Note: All bolts should be inserted from the top. Install the lock washers and hex nuts from the underside of the bench.

Supporting surface where band saw is mounted should be examined carefully after mounting to insure that no movement during use can result. If any tipping or walking is noted, secure workbench or supporting surface before beginning cutting operations.

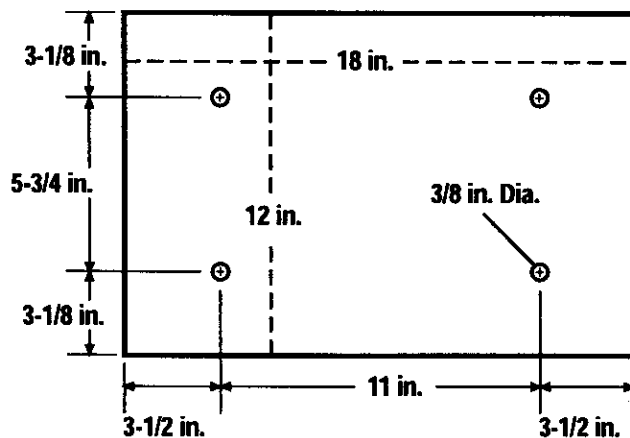

Fig. 9

ASSEMBLY

CLAMPING BAND SAW TO WORKBENCH

See Figure 10.

If the band saw is to be used in a portable application, we recommend that you fasten it permanently to a mounting board that can easily be clamped to a workbench or other supporting surface. The mounting board should be of sufficient size to avoid tipping of saw while in use. Any good grade plywood or chip-board with a 3/4 in. thickness is recommended.

- Mount saw to board using holes in frame as a template for hole pattern or the diagram in Figure 9. Locate and mark the holes where band saw is to be mounted.
- Follow last three steps in previous section called **Mounting Band Saw to Workbench**.

If lag bolts are used, make sure they are long enough to go through holes in the saw and material the saw is being mounted to. If machine bolts are being used, make sure bolts are long enough to go through holes in the saw frame, material being mounted to, lock washers, and hex nuts.

Note: It may be necessary to countersink hex nuts and washers on bottom side of mounting board.

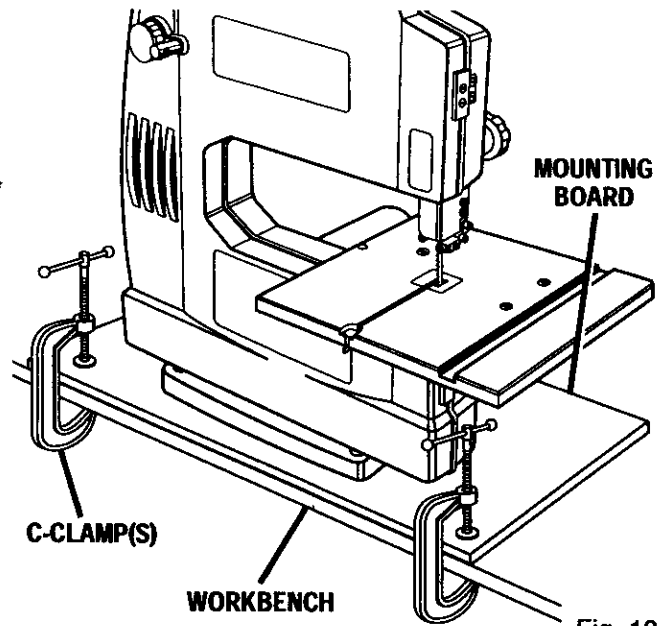

Fig. 10

ADJUSTMENTS

ADJUSTING BLADE GUIDE ASSEMBLY

See Figures 11 and 12.

WARNING: To avoid blade contact, adjust the blade guide assembly to just clear the workpiece, approximately 1/8 in. Failure to do so could result in serious personal injury.

The blade guide assembly should be positioned approximately 1/8 in. above the top surface of the workpiece being cut. This helps to keep the blade from twisting or breaking. Adjust from the back of the band saw.

- Push the lock lever that secures the blade guide assembly counterclockwise or to the left 1/4 turn

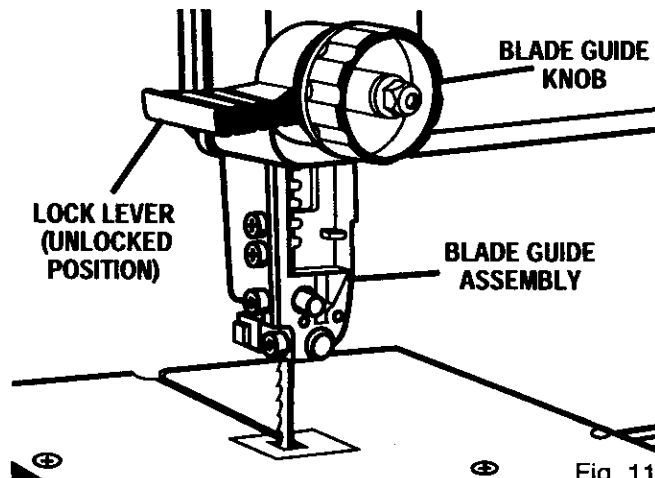

Fig. 11

to unlock the blade guide assembly.

- Rotate the blade guide knob to position the blade guide assembly to the desired position. Use a scrap piece of the same wood you are about to cut as a guide to set the height of the blade guide assembly.
- Lock position in place by returning the lock lever to its upward position. Always lock the blade guide assembly in place before turning on the band saw.

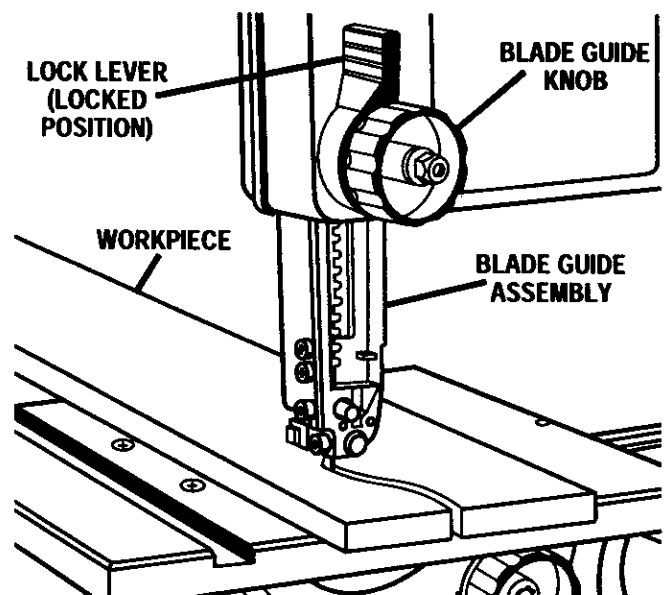

Fig. 12

ADJUSTMENTS

INSTALLING AND ADJUSTING THE BLADE

See Figures 13.

- ▲ **WARNING:** To prevent accidental starting that could cause possible serious personal injury, turn off the saw and unplug the saw before installing or removing blade.
- From the back of the saw, push the lock lever counterclockwise or to the left 1/4 turn to unlock the blade guide assembly. Use the blade guide knob to position the blade guide assembly about half way between the table and the frame. Return the lock lever to its upright locked position. See Figures 11 and 12.
- Open the front cover of the saw by the cover tabs.
- Loosen and remove the wing nut and truss head screw from the table. See Figure 8.

▲ **WARNING:** Always wear safety goggles or safety glasses with side shields to protect your eyes while uncoiling band saw blades. Failure to heed this warning could result in a serious eye injury.

- Wearing gloves, carefully uncoil the blade at arms length. If the new blade was oiled to prevent rusting, it may need to be wiped to keep the oil from your workpiece. Carefully wipe in the same direction the teeth are pointing so the rag does not catch on the teeth of the saw blade.
- Turn the quick release knob counterclockwise or to the left to release the tension. Turn the tension adjusting knob counterclockwise or to the left to lower the upper wheel. See page 15.
- Carefully remove the old blade. The spring on the upper wheel allows it to be pulled down slightly to remove the saw blade from the wheel.
- Slide the new blade into the slot of the table with the teeth of the blade toward the front of the saw and facing down toward the table.

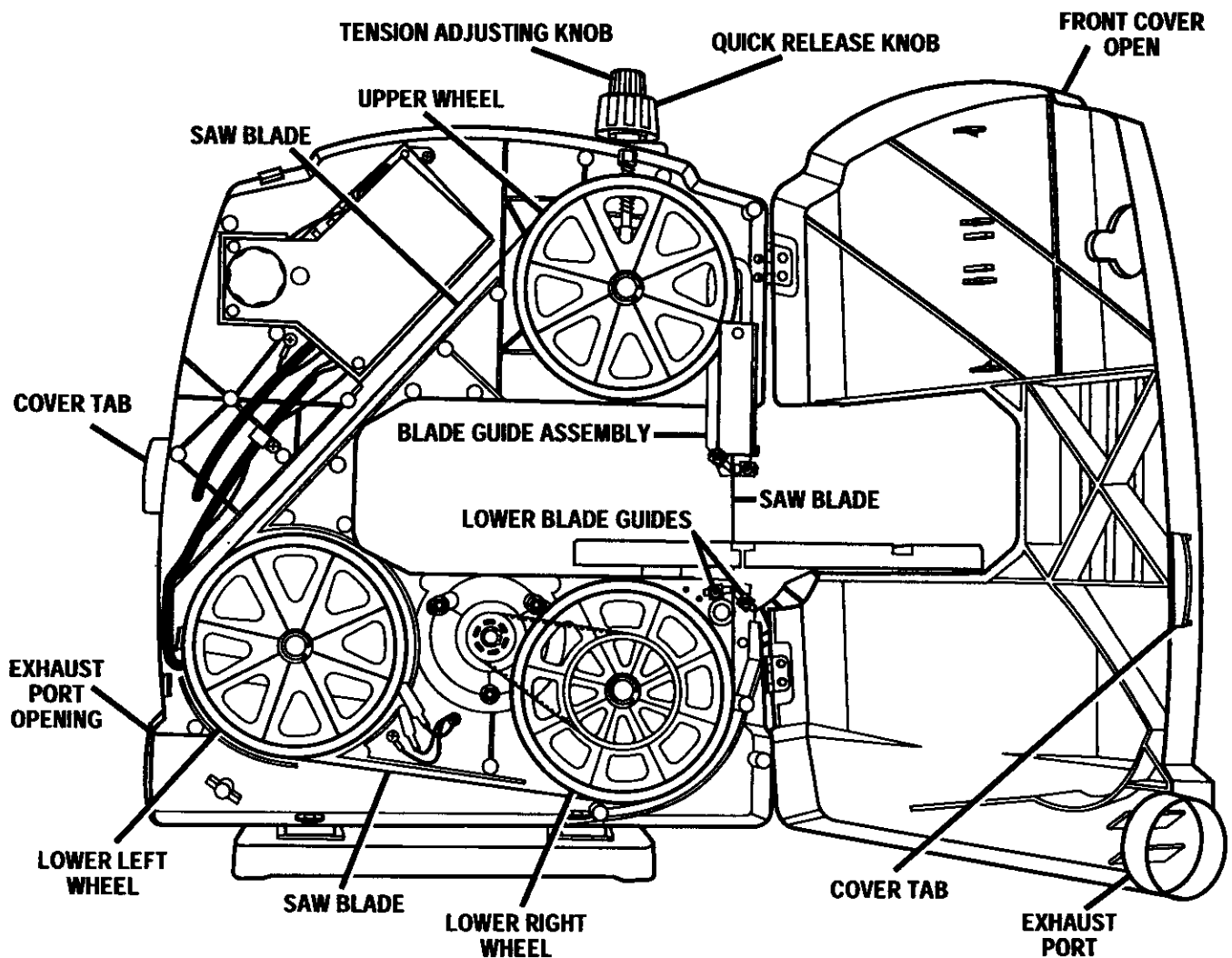

Fig. 13

ADJUSTMENTS

Note: The blade may need to be turned inside out if the teeth are pointing in the wrong direction. Hold the blade with both hands and rotate it inward.

- Place the blade through the upper blade guides and around the upper wheel. Place the blade around the lower wheel on the left. Work the blade around the third wheel making sure it goes between the lower blade guides. Pull down on the upper wheel slightly to place the saw blade on the third wheel, if needed. Slowly turn the upper wheel to the right or clockwise by hand to center the blade on the rubber tires.
- Adjust the blade tension and check or adjust the blade tracking. See pages 15 and 16.
- Adjust both upper and lower blade guides and thrust bearings. See pages 17 and 18.
- Replace the truss head screw and wing nut. Tighten securely.
- Close the cover of the band saw.

ADJUSTING BLADE TENSION

See Figures 14 and 15.

- Turn off and unplug the saw.

WARNING: Failure to unplug your saw could result in accidental starting causing possible serious personal injury.

QUICK RELEASE KNOB

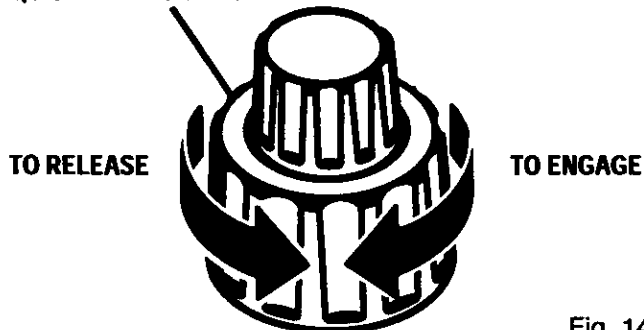

Fig. 14

- The tension adjusting knob is on the top of the saw. Rotate the quick release knob (outer, larger knob) 1/4 turn to the left or counterclockwise to release blade tension.

TENSION ADJUSTING KNOB

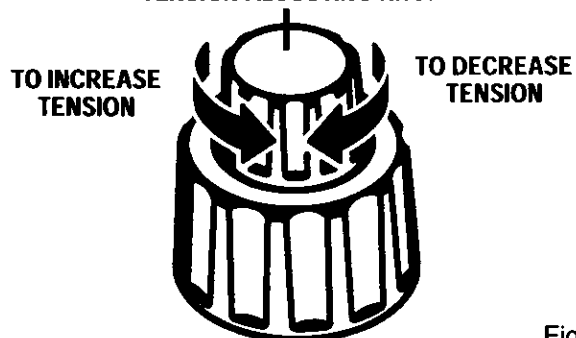

Fig. 15

- Turn the tension adjusting knob (upper, smaller knob) to the right or clockwise to increase tension or raise the upper wheel. Turn it to the left or counterclockwise to decrease tension on the blade or lower the upper wheel.

Note: Adjustments of the blade tension can be made at anytime. The quick release knob can be either released or engaged while making adjustments with the tension adjusting knob.

- Rotate the quick release knob to the right or clockwise 1/4 turn to engage tension before using the band saw.
- To check the tension, raise the blade guide assembly all the way up exposing the blade.
- Pushing the blade to the side with moderate force, the blade should deflect approximately 1/8 in.

Another method of checking the tension has to do with the sound the blade makes when plucked like a guitar string.

- Pluck the back straight edge on the coasting side opposite the blade guides while turning the tension knob. Sound should be a musical note. Sound becomes less flat as tension increases. Sound decreases with too much tension.

Using either method to check tension requires knowing your band saw and can be developed with practice.

- Never tension the blade so tight as to completely compress the spring. The spring can no longer act as a shock absorber.

Note: Be careful not to over tension the blade. Too much tension may cause the blade to break. Too little tension may cause the blade to slip on the wheels.

ADJUSTMENTS

TRACKING THE BLADE

See Figure 16.

Note: Blade tension must be properly adjusted **before** tracking the blade.

- Open the front cover of the saw. Slowly turn the upper wheel to the right or clockwise by hand and watch the blade on the upper tire. If the blade moves away from the center of the tire, the tracking must be adjusted.

TO ADJUST:

- Remove 1/8 in. hex key located in the holder inside the front cover.
- Insert the 1/8 in. hex key into the tracking adjustment screw located on the back of the saw behind the upper wheel.
 - If the blade moved toward the front of the saw turn the adjustment screw in (to the right or clockwise) while turning the wheel by hand, until the blade moves back and rides in the center of the tire.

- If the blade moved away from the front of the saw, turn the adjustment screw out (to the left or counterclockwise) while turning the wheel by hand, until the blade moves forward and rides in the center of the tire.
- Check the position of the blade on the other two tires. The blade should be completely on the tires. If not, adjust the tracking until the blade is on all three tires.
- Rotate the upper wheel by hand in a clockwise direction for a few more turns. Make sure the blade stays in the same location on the tires. Readjust if necessary, until blade is tracking properly.

Note: The 1/8 in. blade may not track properly in the center of the wheel. It may be better to track this blade on the back half of the upper wheel.

- Replace hex key in holder located inside of the front cover. Close front cover.

ALIGNING THE TABLE SQUARE TO THE BLADE

See Figure 17.

⚠ WARNING: To prevent accidental starting that could cause possible serious personal injury, turn off the saw and unplug the saw before making adjustments.

- From the back of the saw, push the lock lever counterclockwise or to the left 1/4 turn to unlock the blade guide assembly.
- Rotate the blade guide knob to move the blade guide assembly all the way up. Return lock lever to the upward position to lock assembly in place.
- Loosen table lock knob. Place a small combination square on table beside blade.
- Rotate angle adjustment knob to tilt the table up or down to align table 90° to blade (0° position). Tighten the table lock knob.
- Using the 1/8 in. hex key, adjust the zero stop set screw until the set screw just touches the frame.
- Check squareness of table to blade. Make readjustments if necessary.
- Loosen screw on scale indicator and align red mark to zero on scale.
- Tighten all screws securely.

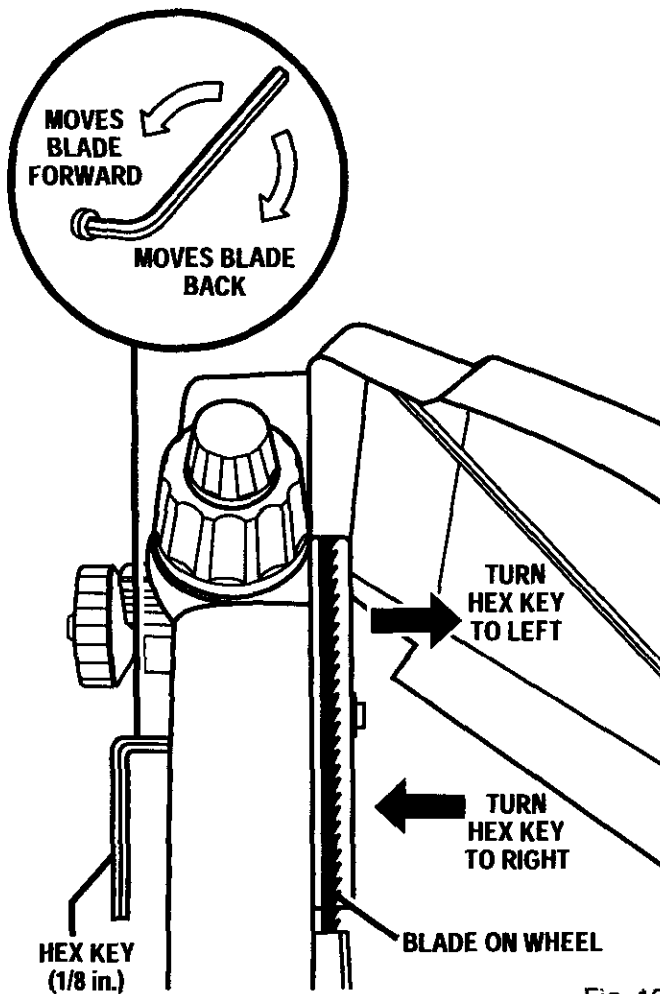

Fig. 16

ADJUSTMENTS

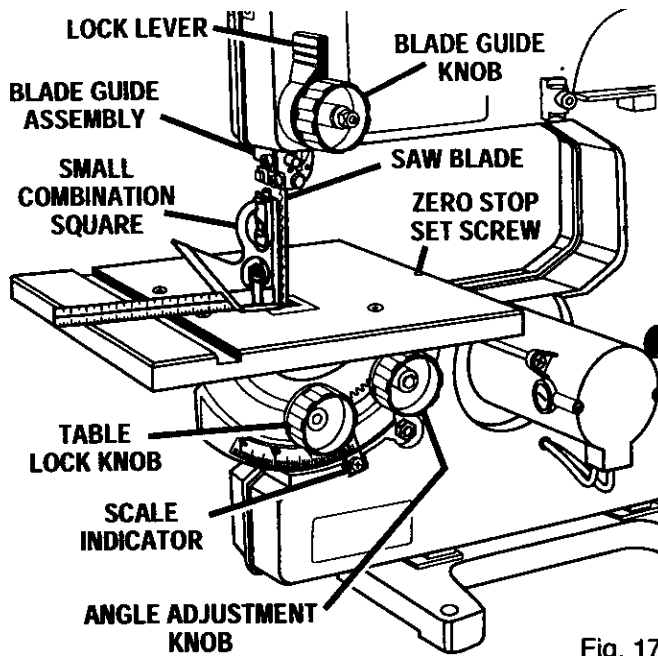

Fig. 17

ADJUSTING THRUST BEARINGS, BLADE GUIDE SUPPORT, AND BLADE GUIDES

See Figures 18, 19, and 20.

The upper and lower blade guides and thrust bearings support the band saw blade during cutting operations. The adjustment of the guides and bearings should be checked whenever a different blade is installed.

⚠ WARNING: To prevent accidental starting that could cause possible serious personal injury, turn off the saw and unplug the saw before making adjustments.

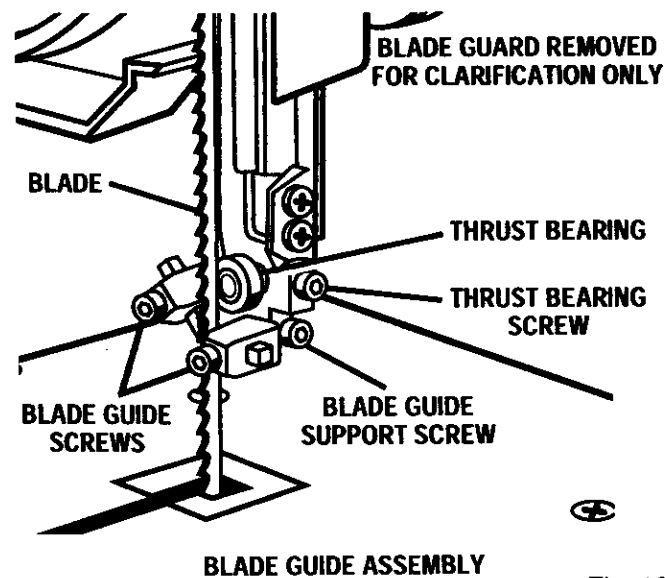

Fig. 18

To Adjust Thrust Bearings

- Adjust the thrust bearings first. Using the 1/8 in. hex key, loosen the thrust bearing screw.
- Note:** The thrust bearing screw is the upper cap screw located on the right side of the blade guide assembly. It is the lower cap screw on the right side of the frame below the table for the lower bearing.

- Move the thrust bearing to within 1/64 in. of the blade. Tighten the thrust bearing screw securely. Repeat this procedure on the lower thrust bearing, located below the table.

Note: The thrust bearing is to support the back edge of the blade while cutting. The blade should not contact the bearings when you stop cutting. It is important that both thrust bearings be adjusted equally.

To Adjust Blade Guide Support

- Next, adjust the position of the blade guide support. Loosen the bottom screw on the right side of the blade assembly using the hex key.
- Slide the blade guide support on the shaft until the front edge of the blade guides are about 1/64 in. behind the gullet of the blade. Tighten the screw securely. Repeat this procedure for the lower blade guide support.

Note: The lower blade guide support screw is the top screw located on the right of the saw frame under the table. See Figure 19.

⚠ WARNING: Never operate saw without blade guard secured in place. To do so could result in possible serious personal injury.

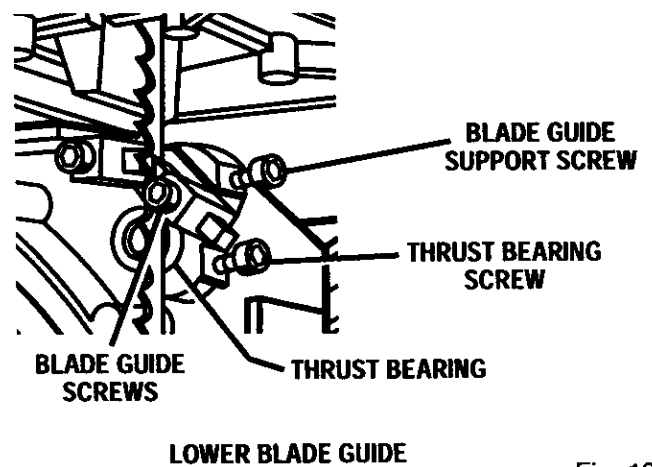

Fig. 19

ADJUSTMENTS

To Adjust Blade Guides

The blade guides help keep the blade from twisting and binding. Letting the blade teeth hit the blade guides while using the band saw will ruin the blade. The set of teeth and the sharpened edge of teeth would be damaged by hitting the blade guides. Proper adjustment of the upper and lower blade guides will prevent this from happening.

- Loosen the two blade guide screws that lock the upper blade guides. Press the two guides evenly near the sides of the blade leaving about 0.004 in. from the blade. (0.004 is the thickness of a dollar bill.) Do not pinch the blade. Make sure one guide is not further away from the blade than the other. Release the guides and tighten both screws securely.
- Repeat this procedure on the lower blade guides located under the table. See Figure 19.

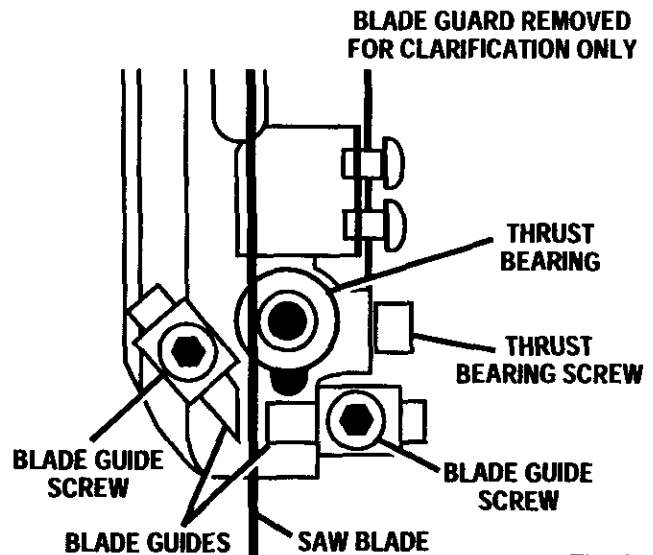

Fig. 20

BASIC OPERATION

This band saw is designed to cut wood, wood composition products, plastic, and nonferrous metals (aluminum, brass, copper).

CAUTION: Do not cut ferrous metals (steel, iron) or hardened steel or serious damage to the saw could result.

ON/OFF KNOB

See Figure 21.

- Pull the knob out to turn the saw ON.

Note: The motor will gradually come up to speed after the saw is turned ON.

- Push the knob in to turn the saw OFF.

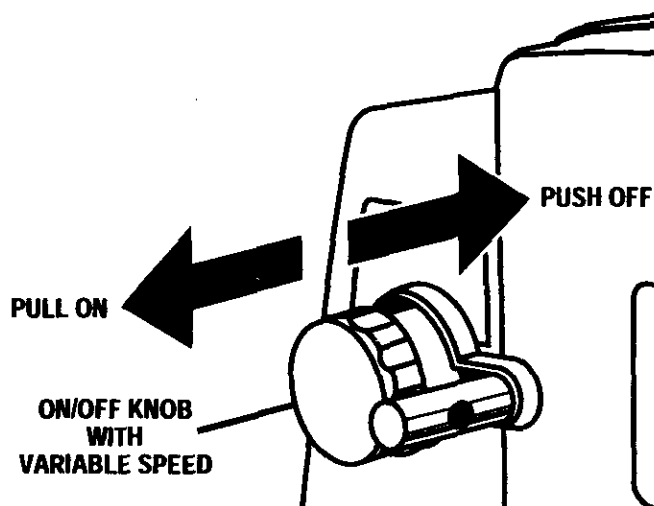

Fig. 21

VARIABLE SPEED

See Figure 22.

The variable speed control may be adjusted to the approximate speeds identified on the On/Off knob label. Turn the knob clockwise or to the right to increase speed, up to 3000 FPM (feet per minute). Turn the knob counterclockwise or to the left to reduce speed as low as 500 FPM (feet per minute).

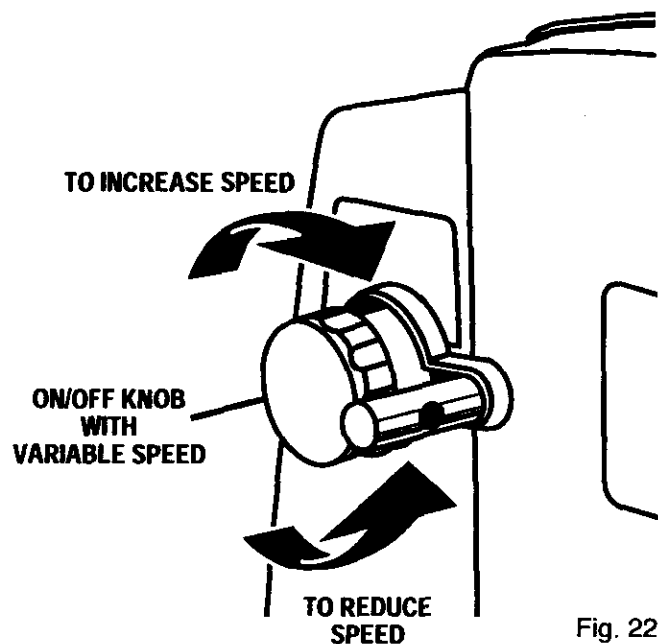

Fig. 22

BASIC OPERATION

LOCK POST

To prevent unauthorized use of your band saw, we suggest that you disconnect it from the power supply and lock the knob in the **OFF** position. A padlock with a shackle of 6 mm or 1/4 in. diameter may be used. When the lock is installed and locked, the switch is inoperable. Store the padlock key in another location.

- To lock knob in **OFF** position, install a padlock through the lock post beside the knob, and lock the padlock.

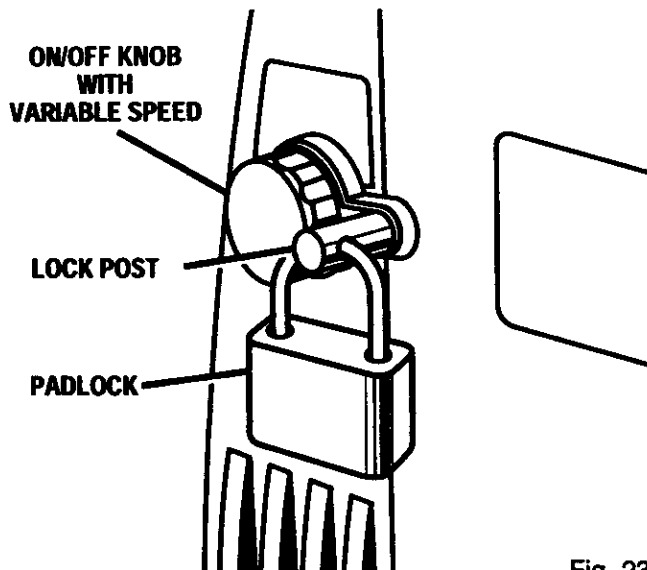

Fig. 23

GENERAL OPERATION

A band saw is basically a "curve cutting" machine. It can also be used for straight-line cutting operations such as cross cutting, ripping, mitering, beveling, compound cutting, and resawing. It is not capable of making inside or non through cuts.

For general type scroll cutting, follow the pattern lines by pushing and turning the workpiece at the same time. Do not try to turn the workpiece while engaged in the blade without pushing it or the workpiece could bind or twist the blade. The blade should cut in the middle of the pattern line since band saw blades are thin.

- Always inspect your band saw for proper adjustments before each use.
- A curved radius cut is best performed by following the pattern line with the blade while turning the workpiece.

- Use both hands while feeding the work into the blade. Hold the workpiece firmly against the table. Use gentle pressure. Do not force the work, but allow the blade to cut.
- The smallest diameter circle that can be cut out is determined by the width of the blade. A 1/4 in. wide blade will cut a minimum diameter of approximately 1-1/2 in. A 1/8 in. wide blade will cut a minimum diameter of approximately 1/2 in.
- Relief cuts are made when an intricate curve (too small a radius for the blade) is to be cut. A relief cut is made by cutting through the scrap section of workpiece to curve in pattern line, then carefully backing blade out. Several relief cuts should be made for intricate curves, then follow pattern line as sections are cut off of curve "relieving" blade pressure.
- **Avoid injury from unexpected saw movement:**
 - Put the saw on a firm level surface with plenty of room for handling and properly supporting the workpiece.
 - Make sure table is level and saw does not rock.
 - Bolt the saw to the support surface to prevent slipping, walking or sliding during operations like cutting long, heavy boards.
 - Turn saw off, lock with padlock, and unplug cord before moving the saw.
- **Avoid injury from jams, slips or thrown pieces:**
 - Choose right size and style blade for material and the type of cut you plan to do.
 - **USE ONLY RECOMMENDED ACCESSORIES.** The use of improper accessories may cause risk of injury to persons.
 - Make sure the blade teeth point downward, toward the table.
 - Make sure blade guides and thrust bearings are properly adjusted.
 - Make sure blade tension is properly adjusted.
 - Make sure table lock knob is tight and no parts have excessive play.
 - Always adjust the blade guide assembly to just clear the workpiece to avoid accidental blade contact, minimize blade breakage and provide maximum blade support.

BASIC OPERATION

■ Use extra caution with large, very small or awkward workpieces:

- Use extra supports (tables, saw horses, blocks, etc.)
- Never use a person as a substitute for a table extension, or as additional support for a workpiece that is longer or wider than the basic saw table, or to help feed, support or pull the workpiece.
- When cutting irregularly shaped workpieces, plan your work so it will not pinch the blade. For example, a piece of molding must lay flat on the table. Workpieces must not twist, rock, or slip while being cut.
- Properly support round material such as dowel rods, or tubing. They have a tendency to roll during a cut, causing the blade to "bite." To avoid this, always use a "V" block or clamp workpiece to a miter gage.
- Cut only one workpiece at a time.
- Clear everything except the workpiece and related support devices off the table before turning the saw on.

■ Plan the way you will hold the workpiece from start to finish:

- Do not hand hold pieces so small that your fingers will go under the blade guard. Keep your hands away from the blade.
- Avoid awkward operations and hand positions where a sudden slip could cause serious injury from contact with the blade. Never place hands in path of blade.

 **WARNING:** Do not allow familiarity with your saw make you careless. Remember that a careless fraction of a second is sufficient to inflict severe injury.

■ When saw is running:

- Before starting your cut, watch the saw while it runs. If you experience excessive vibration or unusual noise, stop immediately. Turn the saw off, lock with padlock, and unplug the saw. Do not restart until locating and correcting problem.

■ Before freeing any jammed material:

- Turn switch **OFF**.
- Wait for all moving parts to stop.
- Unplug the saw.

■ When backing up the workpiece, the blade may bind in the kerf (cut). This is usually caused by sawdust clogging up the kerf or because the blade comes out of the guides. If this happens:

- Turn switch **Off**.
- Wait for all moving parts to stop.
- Unplug the saw.
- Open band saw cover.
- Wedge the kerf open with a flat blade screwdriver or wooden wedge.
- Turn the upper wheel by hand while backing up the workpiece.

■ Before removing loose pieces from the table, turn saw off and wait for all moving parts to stop.

■ Before leaving the saw:

- Turn switch **Off**.
- Wait for all moving parts to stop.
- Lock the knob in the **OFF** position, using a padlock to keep children and others not qualified to use the tool from using the tool.
- Unplug the saw.
- Make workshop child-proof. Lock the shop.

BASIC OPERATION

CHOICE OF BLADE AND SPEED

Your band saw will cut a wide variety of material including wood, wood like products, and nonferrous metals (aluminum, brass, copper).

Note: Inside the front cover of the saw and printed on page 9 in this manual is a blade size label.

- Always use the correct blade for the material being cut.
- Use a fine tooth blade for cutting thin workpieces when a smooth cut is required, when cutting hard material, or when using lower speeds.
- Always use a blade that will have at least 2 teeth in the material at all times.
- For best results, use thin, narrow blades for tight radius work, and thick, wide blades for large curves and straight cuts.
- Match the approximate blade speed (FPM) to the material being cut.

CAUTION: Do not cut ferrous metals (steel, iron) or hardened steel or serious damage to the saw could result.

TYPES OF BLADES AND APPROXIMATE SPEEDS

Material	Speed	Blade	Maximum Thickness
Wood	2460 FPM	General Purposes	3 in.
Plastic	1230 FPM	General Purposes	1/2 in.
Aluminum	1130 FPM	Metal Cutting	1/4 in.
Brass	840 FPM	Metal Cutting	1/4 in.
Copper	400 FPM	Metal Cutting	1/4 in.

METAL CUTTING

Many kinds of metals can be cut with your saw. Be careful not to twist or bend the blades. **Do not force.** If blade heats excessively, use lower speed. If blade teeth become filled or clogged when cutting soft metals, such as aluminum, use a coarser-tooth blade or lower speed. We recommend the use of cutting oil when cutting most soft metals to keep blades cool, increase cutting action, and prolong blade life.

MAINTENANCE

WARNING: When servicing, use only identical Craftsman replacement parts. Use of any other part may create a hazard or cause product damage.

GENERAL MAINTENANCE

Avoid using solvents when cleaning plastic parts. Most plastics are susceptible to damage from various types of commercial solvents and may be damaged by their use. Use clean cloths to remove dirt, carbon dust, etc.

WARNING: Do not at any time let brake fluids, gasoline, petroleum-based products, penetrating oils, etc. come in contact with plastic parts. They contain chemicals that can damage, weaken or destroy plastic.

- Keep your band saw clean.
- Remove sawdust from the inside frequently.
- Do not allow pitch to accumulate on the table, blade guides, or thrust bearings. Clean them with gum and pitch remover.
- Apply a thin coat of automobile type wax to the table top so the wood slides easily while cutting. Also apply wax to the inside surfaces of the angle bracket.

WARNING: To prevent accidental starting that could cause possible serious personal injury, turn off the saw and unplug the saw before working on the band saw.

LUBRICATION

All of the bearings in this tool are lubricated with a sufficient amount of high grade lubricant for the life of the unit under normal operating conditions. Therefore, no further lubrication is required.

TIRES

To properly and safely maintain the wheel tires, the blade should be removed from the band saw. The tires should be kept clean. When the tires become worn they should be replaced.

- Pitch and sawdust that accumulates on the tires should be removed with a fine wire brush or a piece of wood. **Do not** use a sharp knife or any kind of solvent.
- Remove the saw blade, and the worn tires. Stretch the new tires around each wheel.
- Reinstall saw blade.

BRUSH

See Figure 24.

- ⚠ **WARNING:** To prevent accidental starting that could cause possible serious personal injury, turn off the saw, lock knob in the off position, and unplug the saw before working on the band saw,

There is a brush located inside the saw's cover, next to the lower right wheel. The brush helps protect the tire and wheel by brushing off saw dust. As the brush becomes worn, it will need to be adjusted or replaced.

- Loosen the screw to slide the brush and holder toward the wheel. The brush should just touch the wheel.
- Carefully pull the brush straight off of the brush holder to replace the brush. Push the new brush on the holder until you hear it snap in place.
- Remove the brush holder screw to replace both brush and holder.

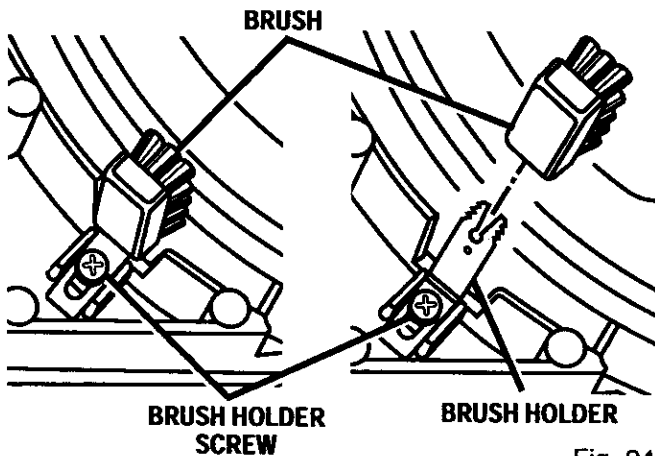

Fig. 24

BLADE GUIDES

See Figures 18 and 19 on page 17.

- The blade guides may become rounded and worn during use. Remove the blade guides and file or grind flat.
- Replace the guides when filing or grinding has worn down guides and they can no longer be properly secured in place.

MOTOR/ELECTRICAL

- Frequently vacuum or blow out any sawdust from the motor.

- ⚠ **WARNING:** If the power cord is worn, cut, or damaged in any way, have it replaced immediately by a qualified service technician at a Sears store. Failure to do so could result in serious personal injury.

- ⚠ **WARNING:** To avoid fire or electrocution, reassemble electric parts with only identical Craftsman replacement parts. Reassemble exactly as originally assembled.

MOTOR BRUSHES

See Figure 24.

- Your saw has externally accessible brush assemblies that should be periodically checked for wear. When one of the two brushes becomes worn, replace both brushes.

- Unplug your saw.

- ⚠ **WARNING:** Failure to unplug your saw could result in accidental starting causing serious injury.

- Remove brush cap with a flat blade screwdriver. Brush assembly is spring loaded and will push against the cap as it releases.
- Remove brush assembly.
- Check for wear. If one brush is worn down shorter than 1/4 in., replace both brushes. **Do not** replace one side without replacing the other.
- Reassemble using new brush assemblies. Make sure curvature of brush matches curvature of motor and that brush moves freely in brush tube.
- Make sure brush cap is oriented correctly (straight) and replace.
- Tighten brush cap securely. Do not overtighten.
- Repeat for other brush.

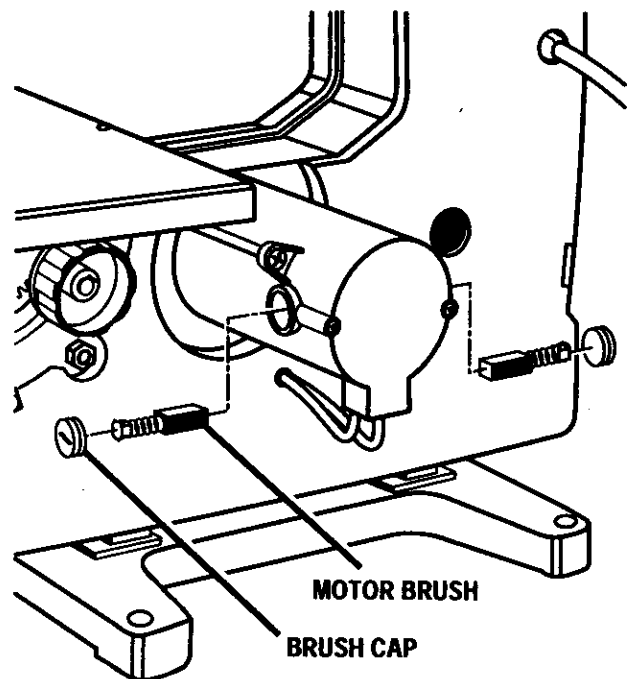

Fig. 24

MAINTENANCE

DRIVE BELT

See Figures 25, 26, 27, and 28.

WARNING: To prevent accidental starting that could cause possible serious personal injury, turn off the saw, lock the knob in the off position, and unplug the saw before working on the band saw.

Due to wear or breakage, the drive belt may need to be replaced. The drive belt is located on the motor pulley and on the lower right wheel of the band saw.

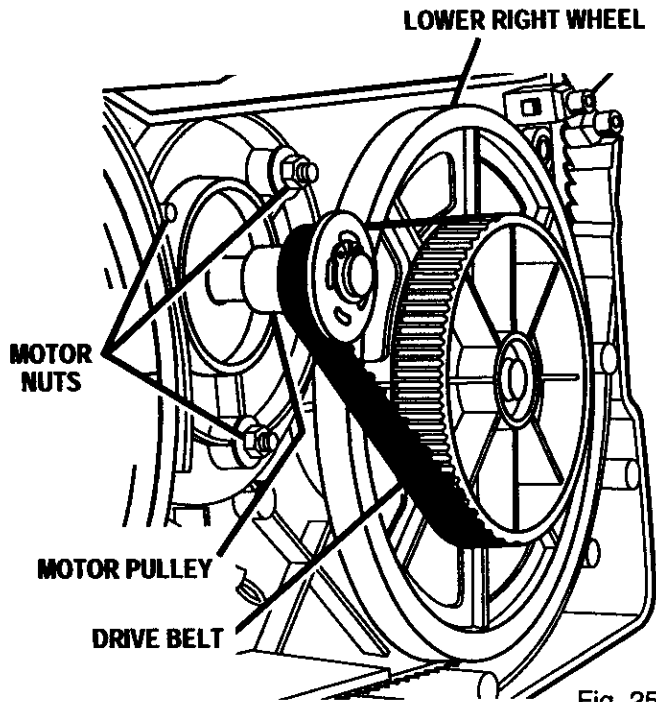

Fig. 25

- Loosen the three motor nuts and rotate the motor to the right or clockwise to reduce tension on the old drive belt.

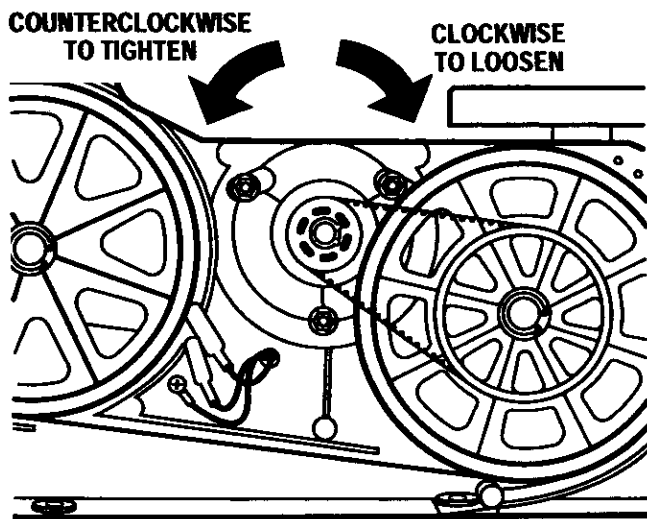

Fig. 26

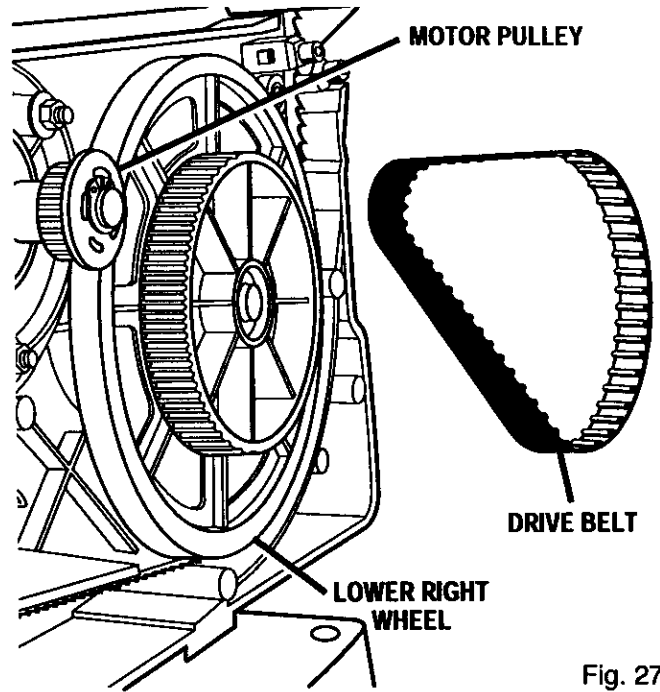

Fig. 27

- Remove the worn drive belt by sliding it off the wheel and then off the motor pulley.
- Matching grooves, place new drive belt on the motor pulley and then on the wheel.
- Rotate the motor to the left or counterclockwise from the front of the saw to apply tension to the drive belt. Using a thumb and finger to squeeze the belt, it should give about 1/4 in. Tighten the three motor nuts.

Note: A drive belt that is too tight may cause increased noise or overload the motor.

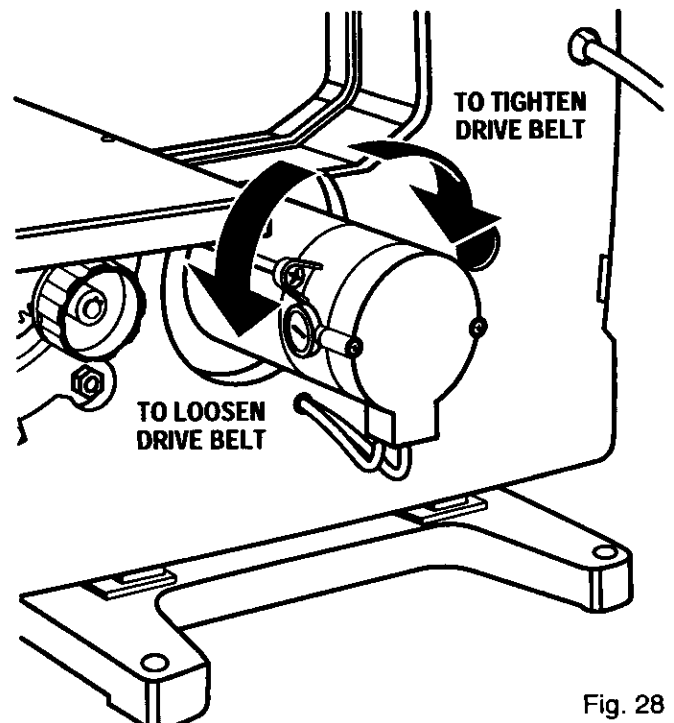

Fig. 28

TROUBLESHOOTING

⚠ WARNING: For your own safety, turn saw Off, lock knob in the off position, and remove plug from power source before adjusting or aligning your band saw.

PROBLEM	CAUSE	SOLUTION
Motor will not run.	<ol style="list-style-type: none"> 1. Problem with On-Off switch or power cord. 2. Motor Defective. 	<ol style="list-style-type: none"> 1. Have worn parts replaced before using Band Saw again. 2. Do not attempt any repair. Have repaired by a qualified service technician at a Sears store.
Blade does not run in the approximate center of the upper wheel.	<ol style="list-style-type: none"> 1. Not tracking properly. 	<ol style="list-style-type: none"> 1. Adjust tracking, See Adjustments section Tracking the Blade.
Band Saw slows down when cutting.	<ol style="list-style-type: none"> 1. Cutting too small a radius. 2. Dull blade. 	<ol style="list-style-type: none"> 1. Stop feeding, and back up the material slightly, until the band saw speeds up. 2. Replace blade.
Blades breaking.	<ol style="list-style-type: none"> 1. Too much tension. 2. Kink in blade caused by cutting too small a radius or turning the material too fast when cutting. 3. Thrust bearings scarred or not rotating. 	<ol style="list-style-type: none"> 1. Adjust tension. See Adjustments section Adjusting Blade Tension. 2. Use correct cutting technique. See section Basic Operation of the Band Saw. 3. Replace the thrust bearings.
Saw is noisy when running.	<ol style="list-style-type: none"> 1. Too much blade tension. 2. Blade guides and backup bearings are in contact with the blade. 	<ol style="list-style-type: none"> 1. Adjust blade tension. See Adjustments section Adjusting Blade Tension. 2. Adjust upper and lower blade guides and bearings. See Adjustments section Adjusting Thrust Bearings, Blade Guide Support, and Blade Guides.
Blade will not cut straight.	<ol style="list-style-type: none"> 1. Blade guides and bearings not properly adjusted. 2. Worn or defective blade. 	<ol style="list-style-type: none"> 1. Adjust upper and lower blade guides and bearings. See Adjustments section Adjusting Thrust Bearings, Blade Guide Support, and Blade Guides. 2. Replace blade.
Blade guides will not stay in position.	<ol style="list-style-type: none"> 1. Blade guide screws have loosened. 	<ol style="list-style-type: none"> 1. Tighten blade guide screws securely.

CRAFTSMAN BAND SAW – MODEL NO. 315.214500

The model number will be found on a plate attached to the frame. Always mention the model number in all correspondence regarding your **BAND SAW** or when ordering repair parts.

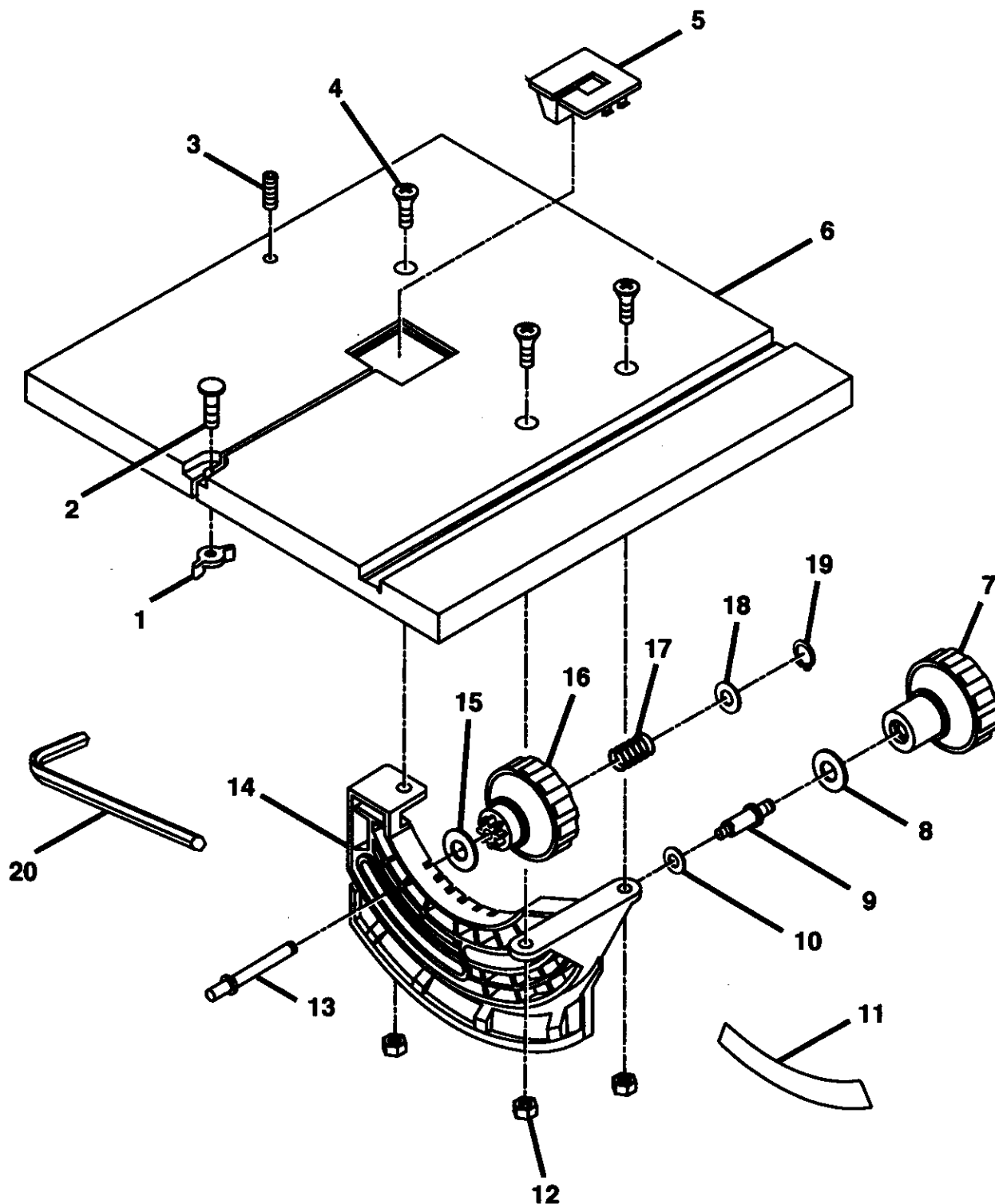

FIGURE A

CRAFTSMAN BAND SAW – MODEL NO. 315.214500

The model number will be found on a plate attached to the frame. Always mention the model number in all correspondence regarding your **BAND SAW** or when ordering repair parts.

SEE BACK PAGE FOR PARTS ORDERING INSTRUCTIONS

PARTS LIST FOR FIGURE A

Key No.	Part Number	Description	Quan.
1	STD541625	** Wing Nut (1/4-20).....	1
2	977095-001	* Screw (1/4-20 x 3/4 in. Truss Hd.).....	1
3	977079-001	* Screw (1/4-20 x 5/8 in. Socket Hd.).....	1
4	977085-001	* Screw (1/4-20 x 7/8 in. Flat Hd.).....	3
5	977027-001	Throat Plate	1
6	977028-001	Table.....	1
7	977030-001	Table Lock Knob	1
8	977092-001	Washer	1
9	977031-001	Spindle	1
10	977093-001	Washer (Shim)	1
11	977086-001	Scale	1
12	STD541025	** Hex Nut (1/4-20)	3
13	977033-001	Angle Adjustment Shaft	1
14	977032-001	Angle Bracket.....	1
15	977105-001	Washer (Shim)	1
16	977029-001	Angle Adjustment Knob	1
17	977065-001	Spring	1
18	STD551025	** Washer	1
19	977088-001	Retaining Ring	1
20	820193-005	* Hex Key 1/8 in. (Item No. 9-28135)	1

* Standard Hardware Item – May Be Purchased Locally

** Available From Division 98 - Source 980.00

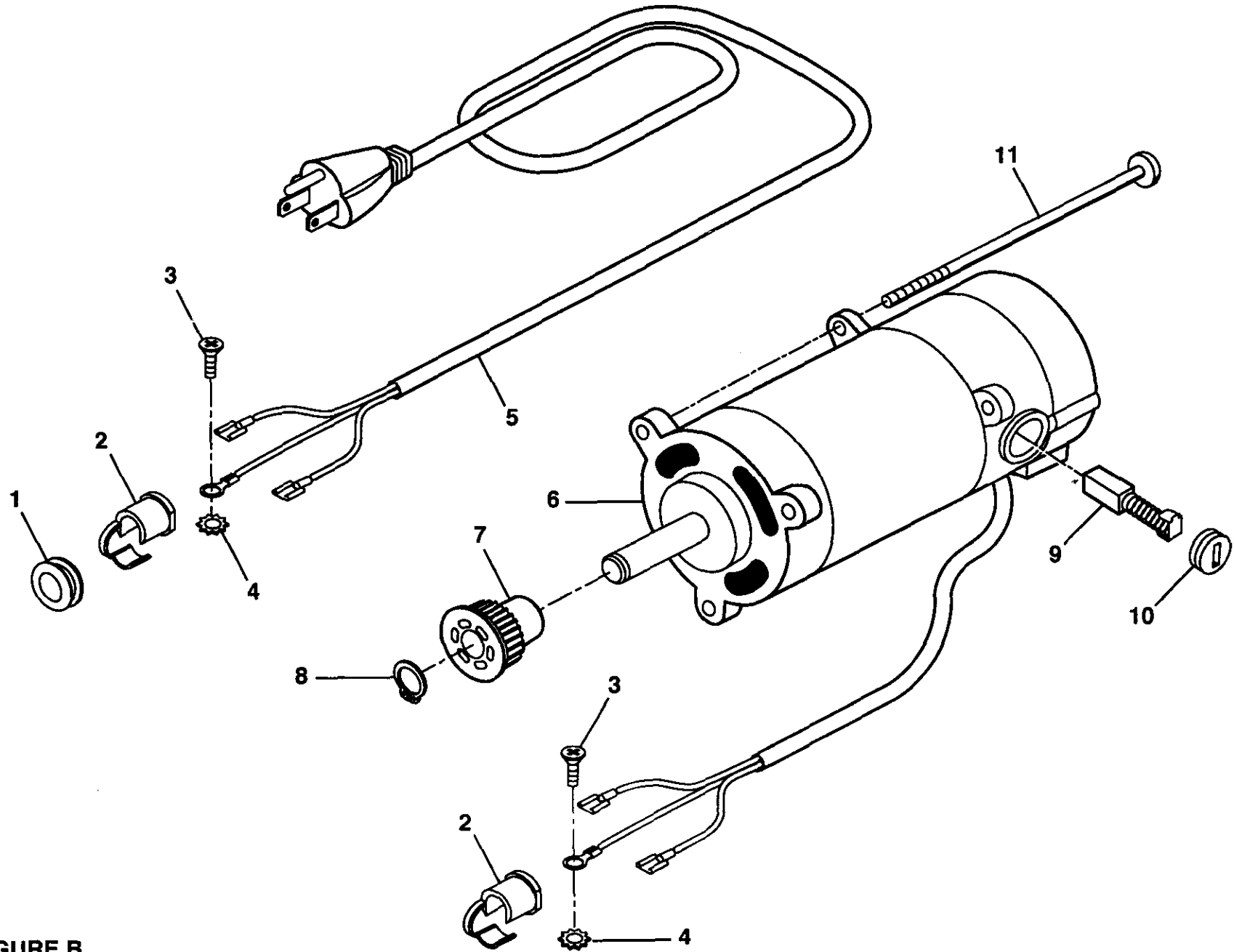

FIGURE B

The model number will be found on a plate attached to the frame. Always mention the model number in all correspondence regarding your **BAND SAW** or when ordering repair parts.

PARTS LIST FOR FIGURE B

Key No.	Part Number	Description	Quan.
1	979861-001	Grommet	1
2	977082-001	Strain Relief	2
3	979865-001	Screw	2
4	980032-001	Washer	2
5	977055-001	Cord	1
6	977059-001	Motor (Includes Key Nos. 9 & 10)	1
7	977016-001	Motor Pulley	1
8	977080-001	Retaining C-Ring	1
9	979863-001	Motor Brush	2
10	979862-001	Brush Cap	2
11	979865-001	Screw	3

CRAFTSMAN BAND SAW - MODEL NO. 315.214500

30

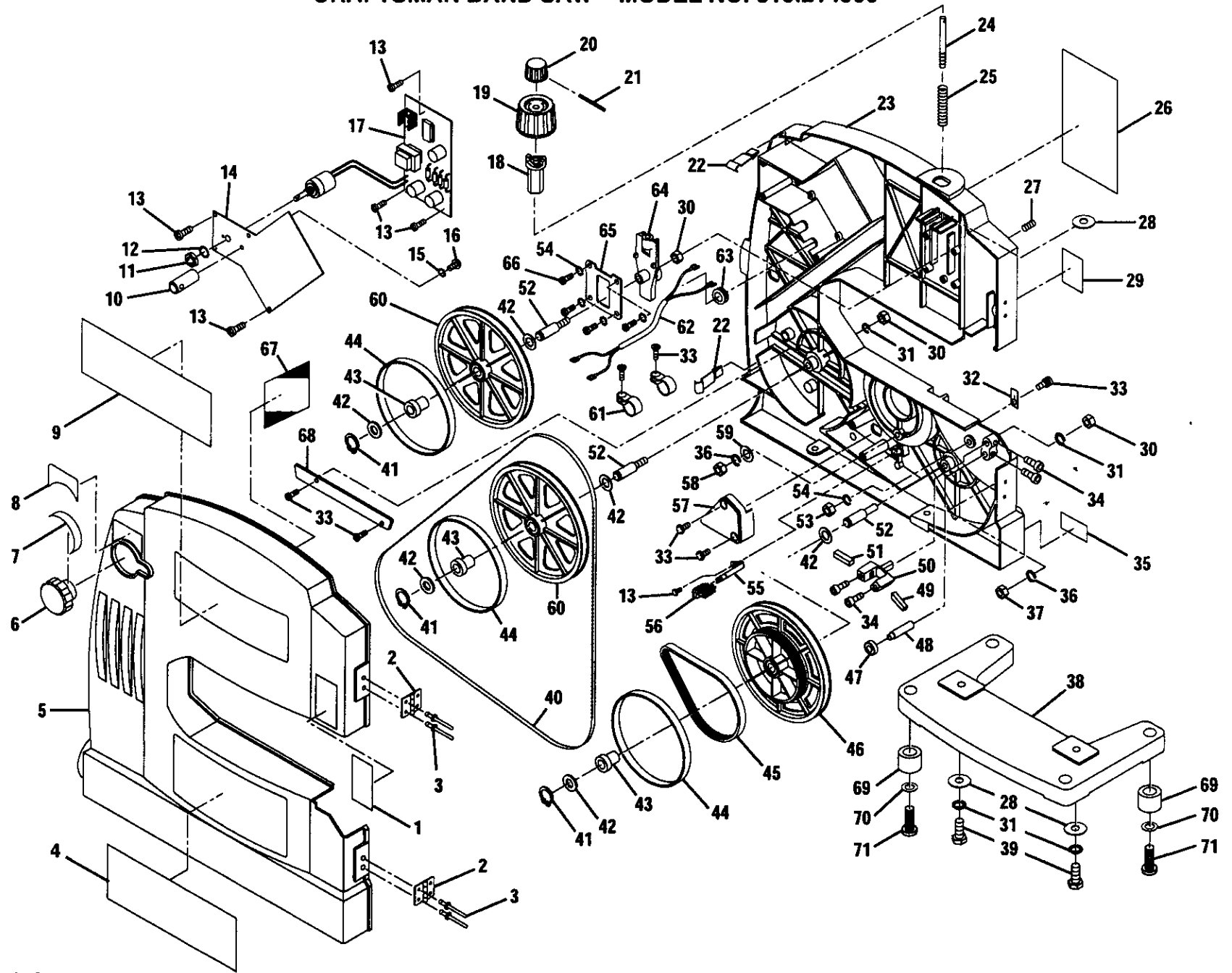

FIGURE C

PARTS LIST FOR FIGURE C

Key No.	Part Number	Description	Quan.	Key No.	Part Number	Description	Quan.
1	977071-001	Hand Warning Label	1	36	STD852005 **	Spring Washer	4
2	977037-001	Hinge	2	37	977091-001	Lock Nut	1
3	977098-001	Rivet	8	38	977036-001	Base	1
4	977074-001	Warning Label	1	39	STD835020 **	Hex Bolt	2
5	977002-001	Front Cover	1	40	***	Saw Blade	1
6	977001-001	Switch Knob	1	41	977080-001	Retaining 'C' Ring	3
7	977195-001	Knob Label	1	42	977196-001	Washer (Shim)	6
8	977188-001	On/Off Label	1	43	977038-001	Bearing Bushing	3
9	977185-001	Logo Plate	1	44	977004-001	Tire	3
10	977039-001	Lock Post	1	45	977035-001	Drive Belt	1
11	977198-001	Hex Nut	1	46	977034-001	Drive Wheel	1
12	977199-001	Washer	1	47	977097-001	Thrust Bearing	1
13	977083-001	Screw	8	48	977023-001	Bearing Pin	1
14	977007-001	Circuit Board Cover	1	49	977024-001	Blade Guide	1
15	980032-001	Star Washer	1	50	977020-001	Blade Guide Support	1
16	979865-001	Screw	1	51	977026-001	Blade Guide	1
17	977008-001	Circuit Board	1	52	977011-001	Wheel Shaft	3
18	977057-001	Cam	1	53	STD840610 **	Hex Nut	1
19	977010-001	Quick Release Knob	1	54	STD852006 **	Spring Washer	5
20	977009-001	Tension Adjustment Knob	1	55	979864-001	Brush Holder	1
21	977081-001	Pin	1	56	977047-001	Brush	1
22	977040-001	Cover Latch	2	57	979866-001	Wire Cover	1
23	977014-001	Frame	1	58	STD541110 **	Hex Nut	3
24	977015-001	Adjustment Shaft	1	59	STD551010 **	Washer	3
25	977197-001	Spring	1	60	977005-001	Wheel	2
26	977189-001	Tension/Tracking Label	1	61	977006-001	Cable Clamp	2
27	977079-001	Tracking Screw	1	62	977041-001	Cord	1
28	STD851008 **	Washer	3	63	979861-001	Grommet	1
29	977069-001	Lock Label	1	64	977013-001	Upper Wheel Support	1
30	STD541031 **	Hex Nut	3	65	977012-001	Upper Wheel Bracket	1
31	STD852008 **	Spring Washer	4	66	STD512503 **	Screw	4
32	977060-001	Indicator	1	67	980035-001	Blade Selection Label	1
33	979865-001	Screw	7	68	977042-001	Wire Cover Plate	1
34	977090-001 *	Screw (Hex Cap)	4	69	980198-001	Rubber Pad	4
35	977186-001	Data Plate	1	70	980064-001	Washer	4
				71	980196-001	Screw	4

* Standard Hardware Item – May Be Purchased Locally

** Available From Division 98 - Source 980.00

*** Available at your nearest Sears Retail Store.

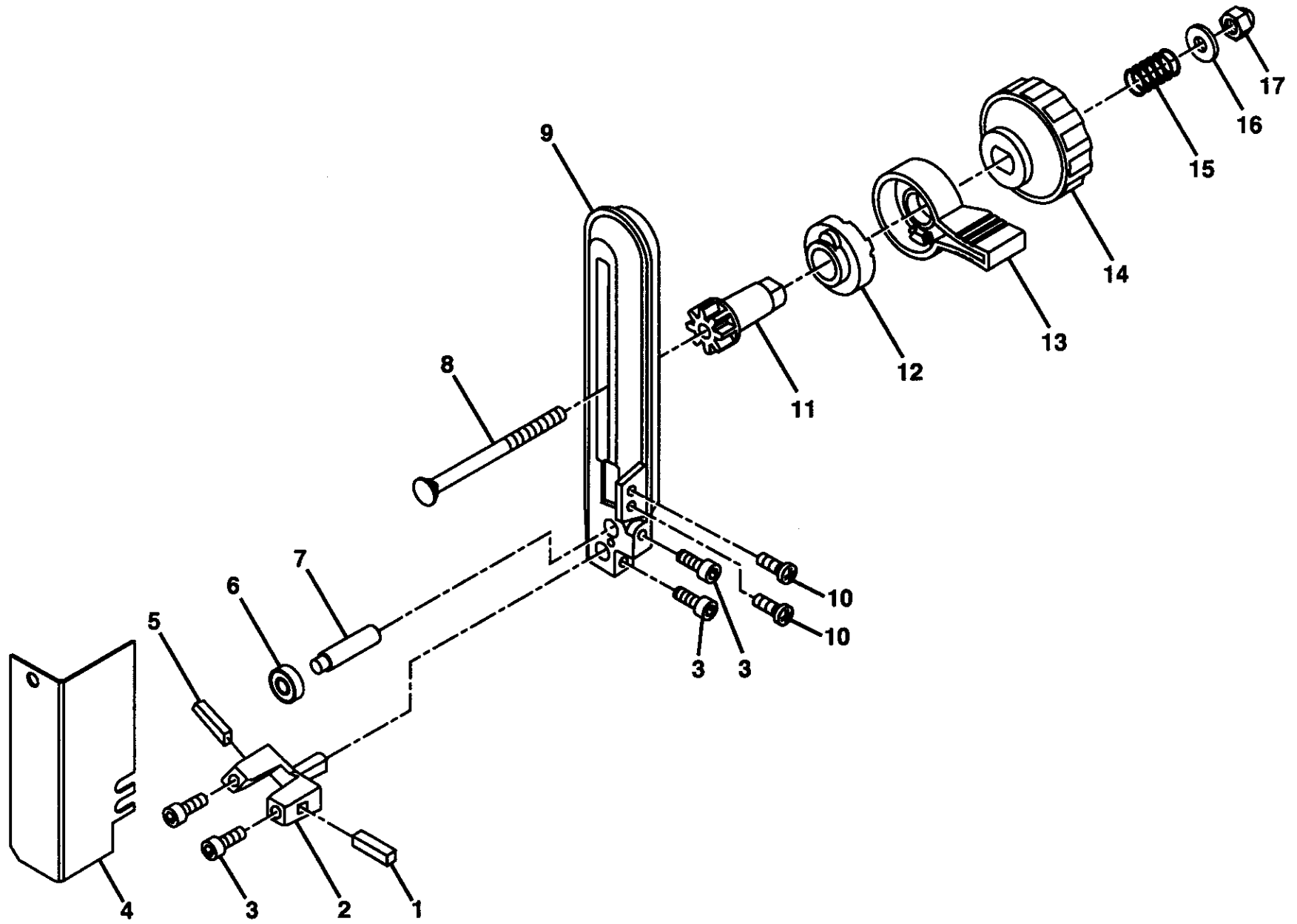

FIGURE D

CRAFTSMAN BAND SAW – MODEL NO. 315.214500

The model number will be found on a plate attached to the frame. Always mention the model number in all correspondence regarding your **BAND SAW** or when ordering repair parts.

PARTS LIST FOR FIGURE D

Key No.	Part Number	Description	Quan.
1	977026-001	Blade Guide	1
2	977020-001	Blade Guide Support.....	1
3	977090-001	* Screw (10-32 x 1/2 in. Hex Cap)	4
4	977025-001	Blade Guard	1
5	977024-001	Blade Guide	1
6	977097-001	Thrust Bearing	1
7	977023-001	Bearing Pin	1
8	977096-001	* Bolt	1
9	977022-001	Blade Guard Support	1
10	977106-001	* Screw (10-24 x 3/8 in. Pan Hd.).....	2
11	977021-001	Pinion	1
12	977019-001	Cam.....	1
13	977018-001	Lock Lever	1
14	977017-001	Blade Guide Knob.....	1
15	977066-001	Spring	1
16	977087-001	Washer (M6)	1
17	STD541425	** Lock Nut (1/4-20)	1
	972000-510	Owner's Manual	1

* Standard Hardware Item — May Be Purchased Locally

** Available From Division 98 - Source 980.00

For in-home major brand repair service:

Call 24 hours a day, 7 days a week

1-800-4-MY-HomeSM (1-800-469-4663)

Para pedir servicio de reparación a domicilio – 1-800-676-5811

In Canada for all your service and parts needs call – **1-800-665-4455**
Au Canada pour tout le service ou les pièces

For the repair or replacement parts you need:

Call 7 am – 7 pm, 7 days a week

1-800-366-PART (1-800-366-7278)

Para ordenar piezas con entrega a domicilio – 1-800-659-7084

For the location of a Sears Parts and Repair Center in your area:

Call 24 hours a day, 7 days a week

1-800-488-1222

**For information on purchasing a Sears Maintenance Agreement
or to inquire about an existing Agreement:**

Call 9 am – 5 pm, Monday – Saturday

1-800-827-6655



The Service Side of SearsSM