

Owner's Manual

CRAFTSMAN®

20.0 HP

ELECTRIC START

46" MOWER

AUTOMATIC

LAWN TRACTOR

Model No.

917.272140

- Safety
- Assembly
- Operation
- Maintenance
- Repair Parts

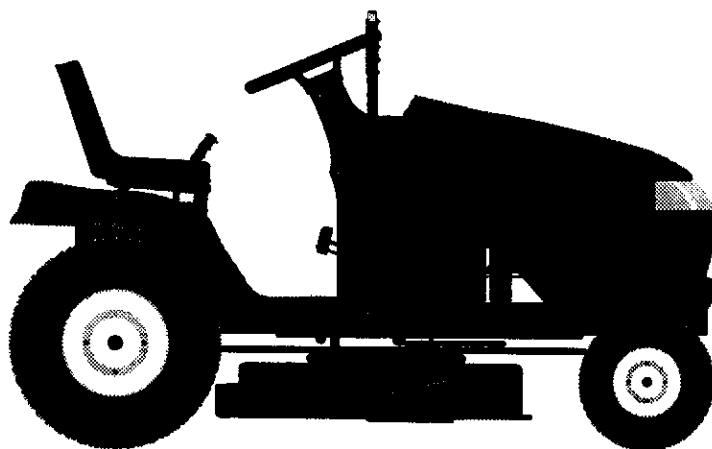

This product has a low emission engine which operates differently from previously built engines. Before you start the engine, read and understand this Owner's Manual.

CAUTION:

Read and follow all Safety Rules and Instructions before operating this equipment.

For answers to your questions about this product, Call:

1-800-659-5917
Sears Craftsman Help Line
5 am - 5 pm, Mon - Sat

Sears, Roebuck and Co., Hoffman Estates, IL 60179

Visit our Craftsman website: www.sears.com/craftsman

TABLE OF CONTENTS

Warranty	2	Maintenance	19
Safety Rules	2	Service and Adjustments	23
Product Specifications	5	Storage	29
Assembly	8	Troubleshooting	30
Operation	12	Repair Parts	34
Maintenance Schedule	19	Parts Ordering	Back Cover

WARRANTY

LIMITED TWO YEAR WARRANTY ON CRAFTSMAN RIDING EQUIPMENT

For two (2) years from the date of purchase, if this Craftsman Riding Equipment is maintained, lubricated and tuned up according to the instructions in the owner's manual, Sears will repair or replace, free of charge, any parts found to be defective in material or workmanship.

This Warranty does not cover:

- Expendable items which become worn during normal use, such as blades, spark plugs, air cleaners, belts, etc.
- Tire replacement or repair caused by punctures from outside objects, such as nails, thorns, stumps, or glass.
- Repairs necessary because of operator abuse, negligence, improper storage or accident or the failure to maintain the equipment according to the instructions contained in the owner's manual.
- Riding equipment used for commercial or rental purposes.

LIMITED 90 DAY WARRANTY ON BATTERY

For ninety (90) days from date of purchase, if any battery included with this riding equipment proves defective in material or workmanship and our testing determines the battery will not hold a charge, Sears will replace the battery at no charge. In-home warranty service on your Craftsman riding equipment is available at no charge for 30 days from the date of purchase. Please contact your nearest service center. After 30 days from the date of purchase, warranty service is available by taking your Craftsman riding equipment to your nearest Sears Service Center. (In-home warranty service will still be available after 30 days from the date of purchase but a standard trip charge will apply). This warranty applies only while this product is in the United States. This Warranty gives you specific legal rights, and you may also have other rights which may vary from state to state.

Sears, Roebuck and Co., D/817 WA, Hoffman Estates, IL 60179

SAFETY RULES

GENERAL OPERATION

- Read, understand, and follow all instructions in the manual and on the machine before starting.
- Only allow responsible adults, who are familiar with the instructions, to operate the machine.
- Clear the area of objects such as rocks, toys, wire, etc., which could be picked up and thrown by the blade.
- Be sure the area is clear of other people before mowing. Stop machine if anyone enters the area.
- Never carry passengers.
- Do not mow in reverse unless absolutely necessary. Always look down and behind before and while backing.
- Be aware of the mower discharge direction and do not point it at anyone. Do not operate the mower without either the entire grass catcher or the guard in place.
- Slow down before turning.
- Never leave a running machine unattended. Always turn off blades, set parking brake, stop engine, and remove keys before dismounting.

SAFETY RULES

- Turn off blades when not mowing.
- Stop engine before removing grass catcher or unclogging chute.
- Mow only in daylight or good artificial light.
- Do not operate the machine while under the influence of alcohol or drugs.
- Watch for traffic when operating near or crossing roadways.
- Use extra care when loading or unloading the machine into a trailer or truck.

SLOPE OPERATION

Slopes are a major factor related to loss-of-control and tipover accidents, which can result in severe injury or death. All slopes require extra caution. If you cannot back up the slope or if you feel uneasy on it, do not mow it.

DO:

- Mow up and down slopes, not across.
- Remove obstacles such as rocks, tree limbs, etc.
- Watch for holes, ruts, or bumps. Uneven terrain could overturn the machine. Tall grass can hide obstacles.
- Use slow speed. Choose a low gear so that you will not have to stop or shift while on the slope.
- Follow the manufacturer's recommendations for wheel weights or counterweights to improve stability.
- Use extra care with grass catchers or other attachments. These can change the stability of the machine.
- Keep all movement on the slopes slow and gradual. Do not make sudden changes in speed or direction.
- Avoid starting or stopping on a slope. If tires lose traction, disengage the blades and proceed slowly straight down the slope.

DO NOT:

- *Do not* turn on slopes unless necessary, and then, turn slowly and gradually downhill, if possible.
- *Do not* mow near drop-offs, ditches, or embankments. The mower could suddenly turn over if a wheel is over the edge of a cliff or ditch, or if an edge caves in.
- *Do not* mow on wet grass. Reduced traction could cause sliding.

- *Do not* try to stabilize the machine by putting your foot on the ground.
- *Do not* use grass catcher on steep slopes.

CHILDREN

Tragic accidents can occur if the operator is not alert to the presence of children. Children are often attracted to the machine and the mowing activity. *Never* assume that children will remain where you last saw them.

- Keep children out of the mowing area and under the watchful care of another responsible adult.
- Be alert and turn machine off if children enter the area.
- Before and when backing, look behind and down for small children.
- Never carry children. They may fall off and be seriously injured or interfere with safe machine operation.
- Never allow children to operate the machine.
- Use extra care when approaching blind corners, shrubs, trees, or other objects that may obscure vision.

SERVICE

- Use extra care in handling gasoline and other fuels. They are flammable and vapors are explosive.
 - Use only an approved container.
 - Never remove gas cap or add fuel with the engine running. Allow engine to cool before refueling. Do not smoke.
 - Never refuel the machine indoors.
 - Never store the machine or fuel container inside where there is an open flame, such as a water heater.
- Never run a machine inside a closed area.
- Keep nuts and bolts, especially blade attachment bolts, tight and keep equipment in good condition.
- Never tamper with safety devices. Check their proper operation regularly.
- Keep machine free of grass, leaves, or other debris build-up. Clean oil or fuel spillage. Allow machine to cool before storing.
- Stop and inspect the equipment if you strike an object. Repair, if necessary, before restarting.

SAFETY RULES

- Never make adjustments or repairs with the engine running.
- Grass catcher components are subject to wear, damage, and deterioration, which could expose moving parts or allow objects to be thrown. Frequently check components and replace with manufacturer's recommended parts, when necessary.
- Mower blades are sharp and can cut. Wrap the blade(s) or wear gloves, and use extra caution when servicing them.
- Check brake operation frequently. Adjust and service as required.



- Be sure the area is clear of other people before mowing. Stop machine if anyone enters the area.
- Never carry passengers.
- Do not mow in reverse unless absolutely necessary. Always look down and behind before and while backing.
- Never carry children. They may fall off and be seriously injured or interfere with safe machine operation.
- Keep children out of the mowing area and under the watchful care of another responsible adult.
- Be alert and turn machine off if children enter the area.
- Before and when backing, look behind and *down* for small children.
- Mow up and down slopes (15° Max), not across.
- Remove obstacles such as rocks, tree limbs, etc.
- Watch for holes, ruts, or bumps. Uneven terrain could overturn the machine. *Tall grass can hide obstacles.*
- Use slow speed. Choose a low gear so that you will not have to stop or shift while on the slope.
- Avoid starting or stopping on a slope. If tires lose traction, disengage the blades and proceed slowly *straight* down the slope.
- *Do not* turn on slopes unless necessary, and then, turn slowly and gradually downhill, if possible.

▲ Look for this symbol to point out important safety precautions. It means **CAUTION!!! BECOME AWARE!!! YOUR SAFETY IS INVOLVED.**

▲ **WARNING:** The engine exhaust from this product contains chemicals known to the State of California to cause cancer, birth defects, or other reproductive harm.

▲ **CAUTION:** In order to prevent accidental starting when setting up, transporting, adjusting or making repairs always disconnect spark plug wire and place wire where it cannot contact spark plug.

PRODUCT SPECIFICATIONS

GASOLINE CAPACITY AND TYPE:	3.5 GALLONS UNLEADED REGULAR
OIL TYPE (API-SF/SG/SH):	SAE -30(above 32°F) SAE 5W-30 (below 32°F)
OIL CAPACITY:	W/FILTER: 3.5 PINTS W/O FILTER: 3.0 PINTS
SPARK PLUG: (GAP: .030")	Champion RJ19LM
VALVE CLEARANCE:	INTAKE: .004"-.006" EXHAUST: .007"-.009"
GROUND SPEED (MPH):	FORWARD: 0 - 5.5 REVERSE: 0 - 2.4
TIRE PRESSURE:	FRONT: 14 PSI REAR: 10 PSI
CHARGING SYSTEM:	16 AMPS@ 3600 RPM
BATTERY:	AMP/HR: 30 MIN. CCA: 240 CASE SIZE: U1R
BLADE BOLT TORQUE:	27-35 FT. LBS.

CONGRATULATIONS on your purchase of a Craftsman Tractor. It has been designed, engineered and manufactured to give you the best possible dependability and performance.

Should you experience any problem you cannot easily remedy, please contact your nearest Sears Authorized Service Center. We have competent, well-trained technicians and the proper tools to service or repair this tractor.

Please read and retain this manual. The instructions will enable you to assemble and maintain your tractor properly. Always observe the "SAFETY RULES".

MAINTENANCE AGREEMENT

A Sears Maintenance Agreement is available on this product. Contact your nearest Sears store for details.

CUSTOMER RESPONSIBILITIES

- Read and observe the safety rules.
- Follow a regular schedule in maintaining, caring for and using your tractor.
- Follow the instructions under "Maintenance" and "Storage" sections of this owner's manual.

▲WARNING: This tractor is equipped with an internal combustion engine and should not be used on or near any unimproved forest-covered, brush-covered or grass-covered land unless the engine's exhaust system is equipped with a spark arrester meeting applicable local or state laws (if any). If a spark arrester is used, it should be maintained in effective working order by the operator.

In the state of California the above is required by law (Section 4442 of the California Public Resources Code). Other states may have similar laws. Federal laws apply on federal lands. A spark arrester for the muffler is available through your nearest Sears Authorized Service Center (See REPAIR PARTS section of this manual).

CONTENTS OF HARDWARE PACK

Parts Bag contents shown full size

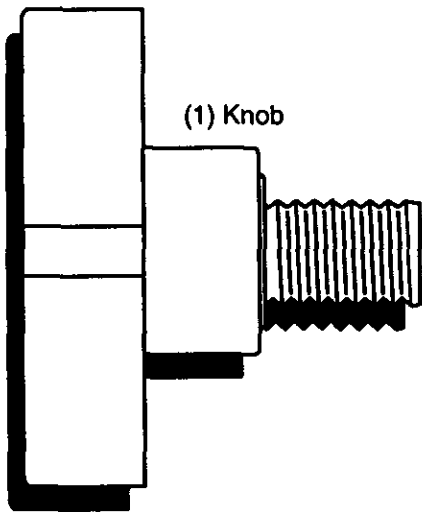

(1) Knob

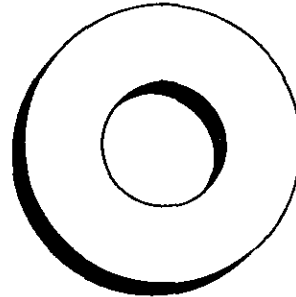

(1) Washer
17/32 x 1-3/16 x 12 Gauge

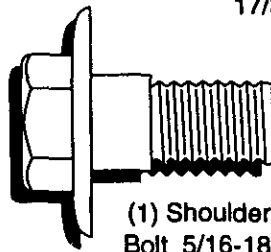

(1) Shoulder
Bolt 5/16-18

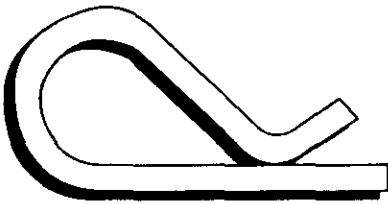

(4) Retainer Springs (single loop)

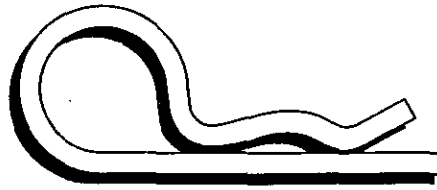

(3) Retainer Springs (double loop)



(2) Screws #10 x 5/8



(2) Lock Washers #10

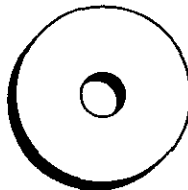

(2) Washers 3/16 x 3/4 x 16 Gauge

(2) Weld Nuts #10

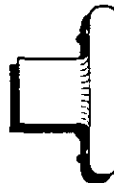

CONTENTS OF HARDWARE PACK

Parts packed separately in carton

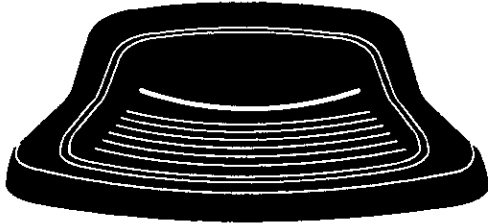

Seat

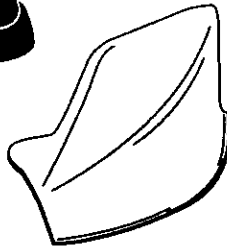

Mulcher
Plate

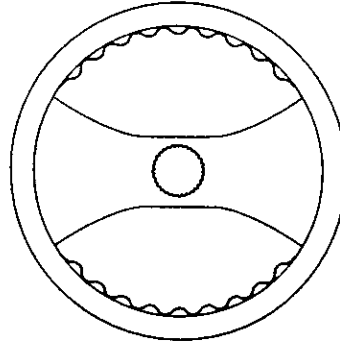

Steering
Wheel

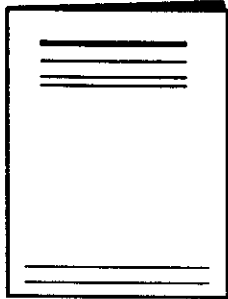

Manual

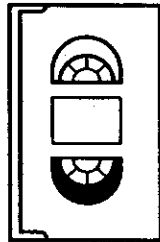

Video
Cassette

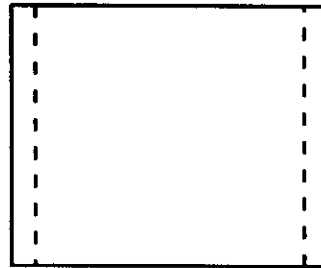

Parts Bag

Parts Bag contents not shown full size

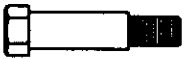

(2) Shoulder
Bolts

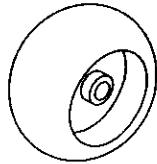

(2) Gauge Wheels



(2) Washers
3/8 x 7/8 x 14 Gauge



(2) Center lock Nuts



Steering Sleeve

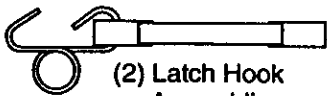

(2) Latch Hook
Assemblies



Steering Sleeve
Extension

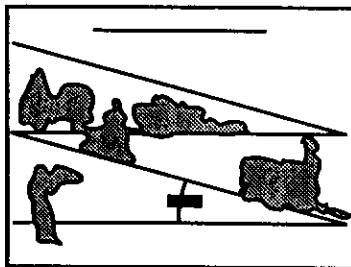

Slope Sheet



(2) Keys

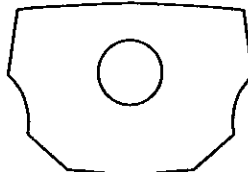

Steering
Wheel
Insert

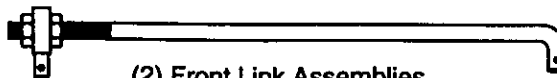

(2) Front Link Assemblies

ASSEMBLY

Your new tractor has been assembled at the factory with exception of those parts left unassembled for shipping purposes. To ensure safe and proper operation of your tractor all parts and hardware you assemble must be tightened securely. Use the correct tools as necessary to insure proper tightness. Review the video cassette before you begin.

TOOLS REQUIRED FOR ASSEMBLY

A socket wrench set will make assembly easier. Standard wrench sizes you need are listed below.

- (2) 1/2" wrench
- (1) 3/4" Socket w/ drive Ratchet
- (1) Pliers
- (1) Utility knife
- (1) Phillips Screwdriver
- (1) Tire pressure gauge

When right or left hand is mentioned in this manual, it means, from your point of view, when you are in the operating position (seated behind the steering wheel).

TO REMOVE TRACTOR FROM CARTON

UNPACK CARTON

- Remove all accessible loose parts and parts boxes from shipping carton (See page 6).
- Cut, from top to bottom, along lines on all four corners of shipping carton, and lay panels flat.
- Remove mower and package materials.
- Check for any additional loose parts or boxes and remove.

BEFORE ROLLING TRACTOR OFF SKID

ATTACH STEERING WHEEL

- Remove locknut and large flat washer from steering shaft.
- Position front wheels of the tractor so they are pointing straight forward.
- Slide the steering sleeve over the steering shaft.
- Align tabs and press steering sleeve extension into bottom of steering wheel.
- Position steering wheel so cross bars are horizontal (left to right) and slide onto adapter.
- Secure steering wheel to steering shaft with locknut and large flat washer previously removed. Tighten securely.
- Snap steering wheel insert into center of steering wheel.
- Remove protective materials from tractor hood and grill.

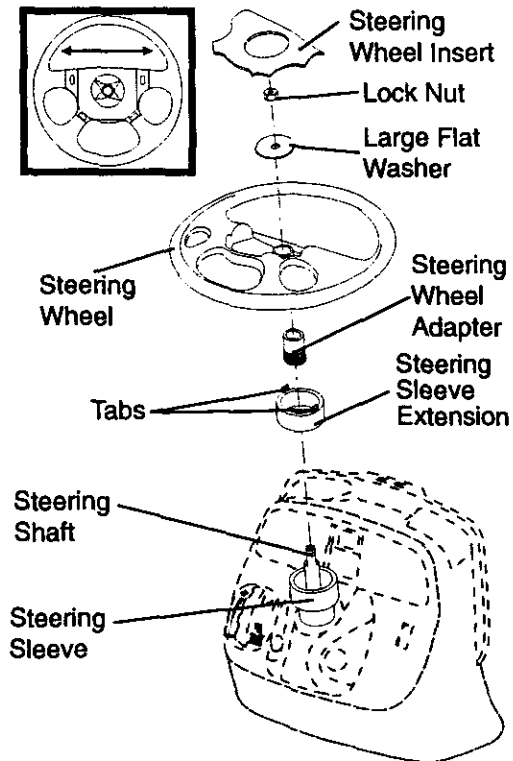

IMPORTANT: Check for and remove any staples in skid that may puncture tires where tractor is to roll off skid.

TO ROLL TRACTOR OFF SKID (See Operation section for location and function of controls)

- Press lift lever plunger and raise attachment lift lever to its highest position.
- Release parking brake by depressing clutch/brake pedal.
- Place freewheel control in freewheeling position to disengage transmission (See "TO TRANSPORT" in the Operation section of this manual).
- Roll tractor forward off skid.

HOW TO SET UP YOUR TRACTOR CONNECT BATTERY

- Lift hood to raised position.
- If this battery is put into service after month and year indicated on label (label located between terminals) charge battery for minimum of one hour at 6-10 amps. (See "BATTERY" in MAINTENANCE section of this manual for charging instructions).

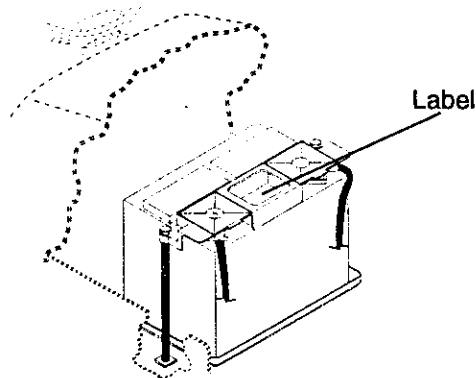

INSTALL SEAT

Adjust seat before tightening adjustment knob.

- Remove cardboard packing on seat pan.
- Place seat on seat pan and assemble shoulder bolt. Tighten shoulder bolt securely.
- Assemble adjustment knob and flat washer loosely. Do not tighten.
- Lower seat into operating position and sit on seat.
- Slide seat until a comfortable position is reached which allows you to press clutch/brake pedal all the way down.
- Get off seat without moving its adjusted position.
- Raise seat and tighten adjustment knob securely.

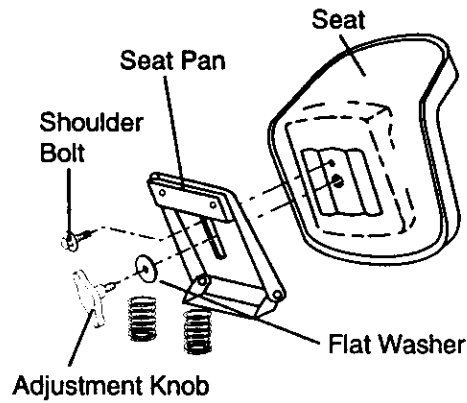

CHECK TIRE PRESSURE

The tires on your tractor were overinflated at the factory for shipping purposes. Correct tire pressure is important for best cutting performance.

- Reduce tire pressure to PSI shown in "PRODUCT SPECIFICATIONS" section of this manual.

CHECK BRAKE SYSTEM

After you learn how to operate your tractor, check to see that the brake is properly adjusted. See "TO ADJUST BRAKE" in the Service and Adjustments section of this manual.

INSTALL MOWER AND DRIVE BELT

Be sure tractor is on level surface and mower suspension arms are raised with attachment lift control. Engage parking brake.

- Cut and remove ties securing anti-sway bar and belts. Swing anti-sway bar to left side of mower deck.
- Slide mower under tractor with discharge guard to right side of tractor.
- IMPORTANT:** Check belt for proper routing in all mower pulley grooves. Install belt into electric clutch pulley groove.
- Install one front link in top hole of the right hand front mower bracket and right hand front suspension bracket. Retain with two single loop retainer springs as shown.
- Install second front link in left hand front suspension bracket only and retain with single loop retainer spring as shown.
- Turn height adjustment knob counter-clockwise until it stops.
- Lower mower linkage with attachment lift control.

- Place the left hand suspension arm on outward pointing deck pin. If necessary, rock and raise front of mower to align deck pin with the hole in suspension arm. Retain with double loop retainer spring with loops down as shown.
- Slide left side of mower back and install the unattached front link in top hole of the left hand front mower bracket. Retain with single loop retainer spring as shown.
- Place the right hand suspension arm on outward pointing deck pin. If necessary, rock and raise front of mower to align deck pin with the hole in suspension arm. Retain with double loop retainer spring with loops down as shown.
- Connect anti-sway bar to chassis bracket under left footrest and retain with double loop retainer spring.
- Turn height adjustment knob clockwise to remove slack from mower suspension.
- Raise mower to highest position.
- Assemble gauge wheels (See "TO ADJUST GAUGE WHEELS" in the Operation section of this manual).

CHECK MOWER LEVELNESS

For best cutting results, mower should be properly leveled. See "TO LEVEL MOWER HOUSING" in the Service and Adjustments section of this manual.

CHECK FOR PROPER POSITION OF ALL BELTS

See the figures that are shown for replacing motion, mower drive, and mower blade drive belts in the Service and Adjustments section of this manual. Verify that the belts are routed correctly.

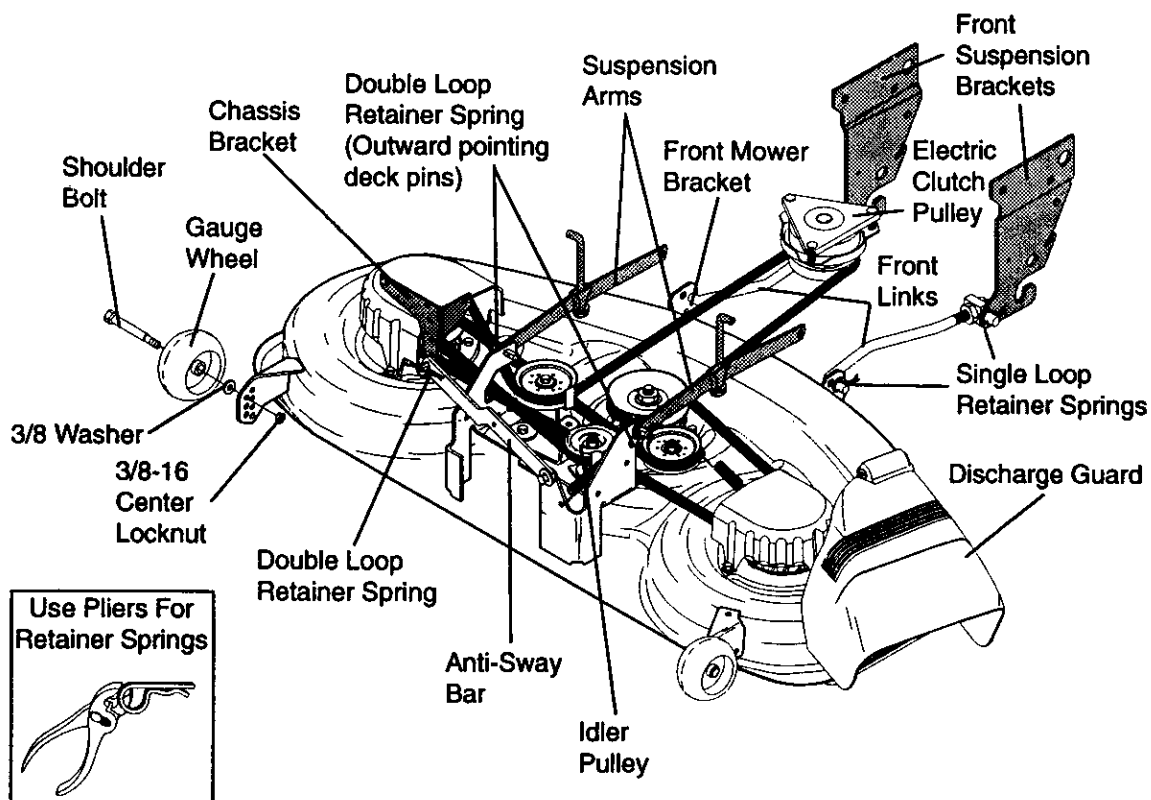

INSTALL MULCHER PLATE

- Install two latch hooks to mulcher plate using screw, washer, lock washer, and weld nut as shown.

NOTE: Pre-assemble weld nut to latch hook by inserting weld nut from the top with hook pointing down.

- Tighten hardware securely.
- Raise and hold deflector shield in upright position.
- Place front of mulcher plate over front of mower deck opening and slide into place, as shown.
- Hook front latch into hole on front of mower deck.
- Hook rear latch into hole on back of mower deck.

▲CAUTION: Do not remove discharge guard from mower. Raise and hold guard when attaching mulcher plate and allow it to rest on plate while in operation.

TO CONVERT TO BAGGING OR DISCHARGING

Simply remove mulcher plate and store in a safe place. Your mower is now ready for discharging or installation of optional grass catcher accessory.

NOTE: It is not necessary to change blades. The mulcher blades are designed for discharging and bagging also.

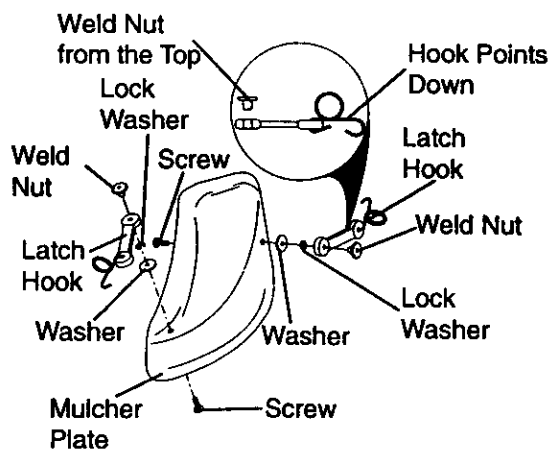

✓CHECKLIST

PLEASE REVIEW THE FOLLOWING CHECKLIST:

- ✓ All assembly instructions have been completed.
- ✓ No remaining loose parts in carton.
- ✓ Battery is properly prepared and charged. (Minimum 1 hour at 6 amps).
- ✓ Seat is adjusted comfortably and tightened securely.
- ✓ All tires are properly inflated. (For shipping purposes, the tires were overinflated at the factory).
- ✓ Be sure mower deck is properly leveled side-to-side/front-to-rear for best cutting results. (Tires must be properly inflated for leveling).
- ✓ Check mower and drive belts. Be sure they are routed properly around pulleys and inside all belt keepers.
- ✓ Check wiring. See that all connections are still secure and wires are properly clamped.
- ✓ Before driving tractor, be sure free-wheel control is in drive position.

WHILE LEARNING HOW TO USE YOUR TRACTOR, PAY EXTRA ATTENTION TO THE FOLLOWING IMPORTANT ITEMS:

- ✓ Engine oil is at proper level.
- ✓ Fuel tank is filled with fresh, clean, regular unleaded gasoline.
- ✓ Become familiar with all controls - their location and function. Operate them before you start the engine.
- ✓ Be sure brake system is in safe operating condition.
- ✓ It is important to purge the transmission before operating your tractor for the first time. Follow proper starting and transmission purging instructions (See "TO START ENGINE" and "PURGE TRANSMISSION" in the Operation section of this manual).

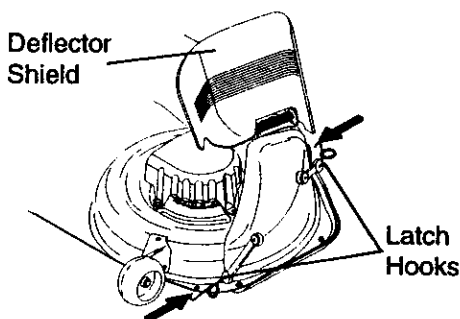

OPERATION

These symbols may appear on your tractor or in literature supplied with the product. Learn and understand their meaning.



BATTERY



CAUTION OR WARNING



REVERSE



FORWARD



FAST



SLOW



ENGINE ON



ENGINE OFF



OIL PRESSURE



LIGHTS ON



OVER TEMP LIGHT

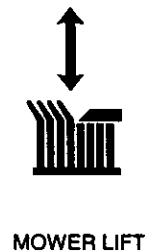

MOWER LIFT



FUEL



CHOKE



MOWER HEIGHT



PARKING BRAKE LOCKED



UNLOCKED



ATTACHMENT CLUTCH ENGAGED



REVERSE



NEUTRAL



HIGH



LOW



PARKING BRAKE



IGNITION



ATTACHMENT CLUTCH DISENGAGED



KEEP AREA CLEAR



(SEE SAFETY RULES SECTION)



SLOPE HAZARDS



DANGER, KEEP HANDS AND FEET AWAY

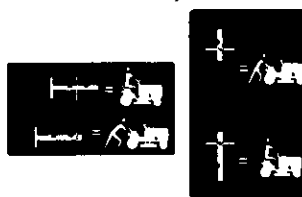

FREE WHEEL (Automatic Models only)

KNOW YOUR TRACTOR

READ THIS OWNER'S MANUAL AND SAFETY RULES BEFORE OPERATING YOUR TRACTOR

Compare the illustrations with your tractor to familiarize yourself with the locations of various controls and adjustments. Save this manual for future reference.

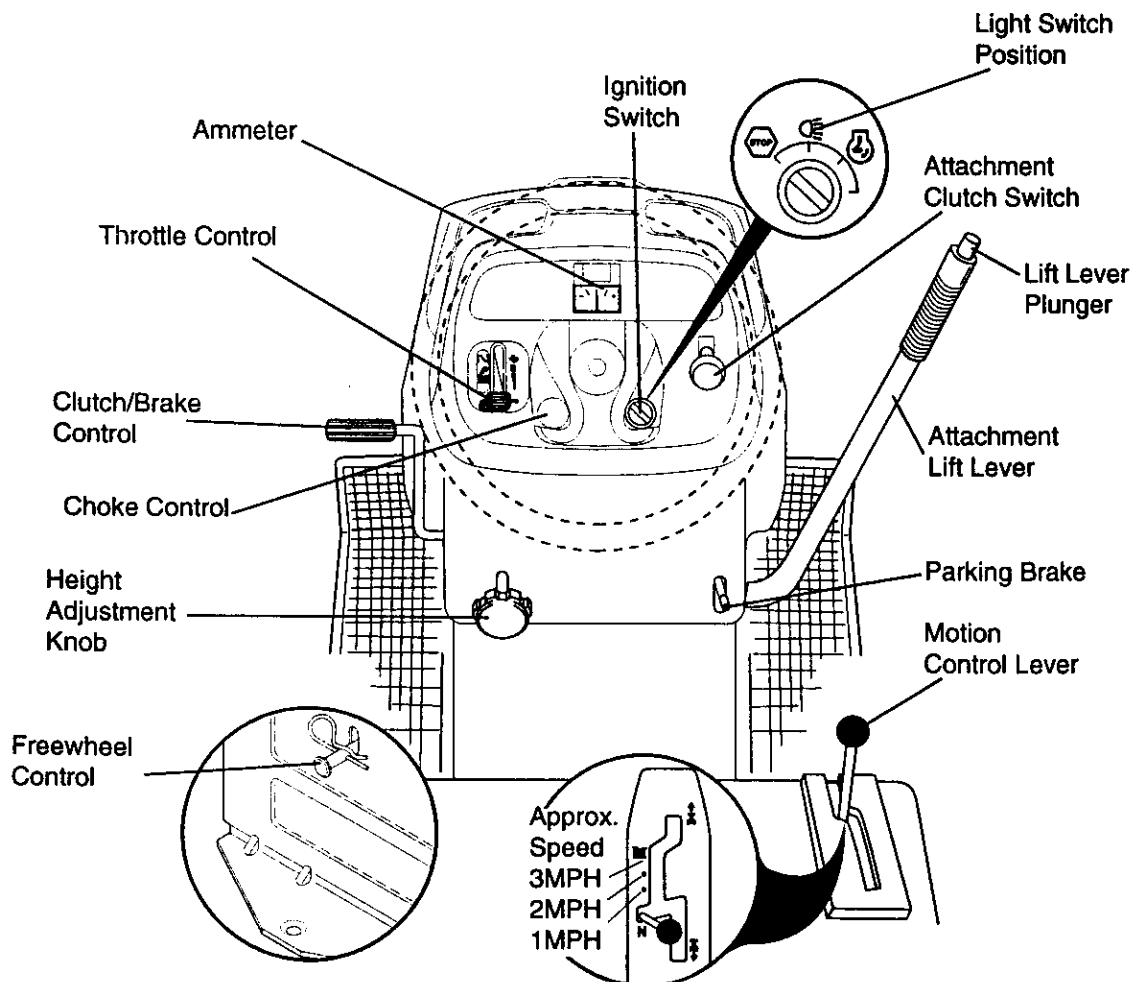

Our tractors conform to the safety standards of the American National Standards Institute.

ATTACHMENT CLUTCH SWITCH: Used to engage the mower blades, or other attachments mounted to your tractor.

CHOKE CONTROL: Used when starting a cold engine.

LIGHT SWITCH: Turns the headlights on and off.

THROTTLE: Used to control engine speed.

CLUTCH/BRAKE PEDAL: Used for declutching and braking the tractor and starting the engine.

FREEWHEEL CONTROL: Disengages transmission for pushing or slowly towing the tractor with the engine off.

HEIGHT ADJUSTMENT KNOB: Used to adjust the mower cutting height.

MOTION CONTROL LEVER: Selects the speed and direction of the tractor.

ATTACHMENT LIFT LEVER: Used to raise and lower the mower deck or other attachments mounted to your tractor.

LIFT LEVER PLUNGER: Used to release attachment lift lever when changing its position.

IGNITION SWITCH: Used for starting and stopping the engine.

AMMETER: Indicates battery charging (+) or discharging (-).

PARKING BRAKE: Locks clutch/brake into the brake position.



The operation of any tractor can result in foreign objects thrown into the eyes, which can result in severe eye damage. Always wear safety glasses or eye shields while operating your tractor or performing any adjustments or repairs. We recommend a wide vision safety mask over spectacles, or standard safety glasses.

HOW TO USE YOUR TRACTOR TO SET PARKING BRAKE

Your tractor is equipped with an operator presence sensing switch. When engine is running, any attempt by the operator to leave the seat without first setting the parking brake will shut off the engine.

- Depress clutch/brake pedal into full "BRAKE" position and hold.
- Place parking brake lever in "EN-GAGED" position and release pressure from clutch/brake pedal. Pedal should remain in "BRAKE" position. Make sure parking brake will hold tractor secure.

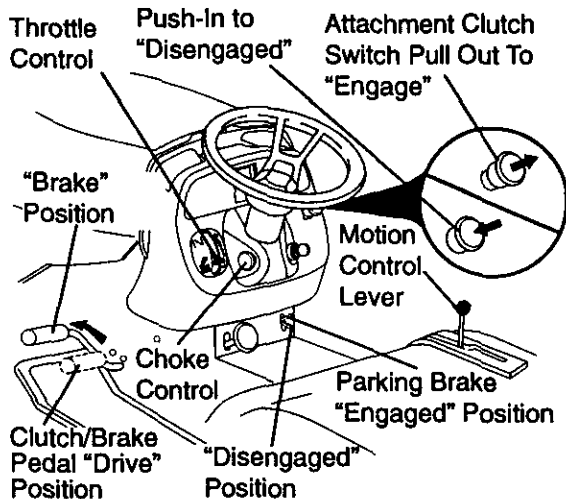

STOPPING

MOWER BLADES -

- To stop mower blades, move attachment clutch switch to "DISENGAGED" position.

GROUND DRIVE -

- To stop ground drive, depress clutch/brake pedal into full "BRAKE" position.
- Move motion control lever to neutral (N) position.

IMPORTANT: The motion control lever does not return to neutral (N) position when the clutch/brake pedal is depressed.

ENGINE -

- Move throttle control to slow position.

NOTE: Failure to move throttle control to slow position and allowing engine to idle before stopping may cause engine to "backfire".

- Turn ignition key to "OFF" position and remove key. Always remove key when leaving tractor to prevent unauthorized use.
- Never use choke to stop engine.

IMPORTANT: Leaving the ignition switch in any position other than "OFF" will cause the battery to be discharged, (dead).

NOTE: Under certain conditions when tractor is standing idle with the engine running, hot engine exhaust gases may cause "browning" of grass. To eliminate this possibility, always stop engine when stopping tractor on grass areas.

CAUTION: Always stop tractor completely, as described above, before leaving the operator's position; to empty grass catcher, etc.

THROTTLE CONTROL

Always operate engine at full throttle.

- Operating engine at less than full throttle reduces the battery charging rate.
- Full throttle offers the best bagging and mower performance.

CHOKE CONTROL

Use choke control whenever you are starting a cold engine. Do not use to start a warm engine.

- To engage choke control, pull knob out. Slowly push knob in to disengage.

TO MOVE FORWARD AND BACKWARD

The direction and speed of movement is controlled by the motion control lever.

- Start tractor with motion control lever in neutral (N) position.
- Release parking brake and clutch/brake pedal.
- Slowly move motion control lever to desired position.

TO ADJUST MOWER CUTTING HEIGHT

The cutting height is controlled by turning the height adjustment knob in desired direction.

- Turn knob clockwise (C) to raise cutting height.
- Turn knob counterclockwise (O) to lower cutting height.

The cutting height range is approximately 1-1/2" to 4". The heights are measured from the ground to the blade tip with the engine not running. These heights are approximate and may vary depending upon soil conditions, height of grass and types of grass being mowed.

- The average lawn should be cut to approximately 2-1/2 inches during the cool season and to over 3 inches during hot months. For healthier and better looking lawns, mow often and after moderate growth.
- For best cutting performance, grass over 6 inches in height should be mowed twice. Make the first cut relatively high; the second to desired height.

TO ADJUST GAUGE WHEELS

Gauge wheels are properly adjusted when they are slightly off the ground when mower is at the desired cutting height in operating position. Gauge wheels then keep the deck in proper position to help prevent scalping in most terrain conditions.

- Adjust gauge wheels with tractor on a flat level surface.
- Adjust mower to desired cutting height (See "TO ADJUST MOWER CUTTING HEIGHT" in the Operation section of this manual).
- With mower in desired height of cut position, gauge wheels should be assembled so they are slightly off the ground. Install gauge wheel in appropriate hole with shoulder bolt, 3/8 washer, and 3/8-16 locknut and tighten securely.
- Repeat for opposite side installing gauge wheel in same adjustment hole.

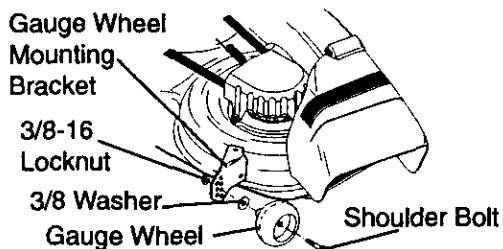

TO OPERATE MOWER

Your tractor is equipped with an operator presence sensing switch. Any attempt by the operator to leave the seat with the engine running and the attachment clutch engaged will shut off the engine.

- Select desired height of cut.
- Lower mower with attachment lift control.

- Start mower blades by engaging attachment clutch control.
- TO STOP MOWER BLADES - disengage attachment clutch control.

CAUTION: Do not operate the mower without either the entire grass catcher, on mowers so equipped, or the discharge guard in place.

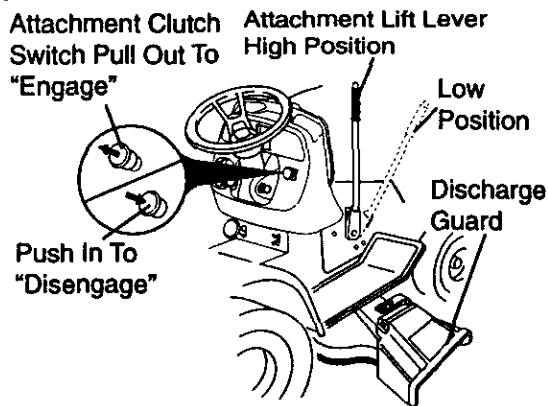

TO OPERATE ON HILLS

CAUTION: Do not drive up or down hills with slopes greater than 15° and do not drive across any slope. Use the slope guide provided at the back of this manual.

- Choose the slowest speed before starting up or down hills.
- Avoid stopping or changing speed on hills.
- If slowing is necessary, move throttle control lever to slower position.
- If stopping is absolutely necessary, push clutch/brake pedal quickly to brake position and engage parking brake.
- Move motion control lever to neutral (N) position.

IMPORTANT: The motion control lever does not return to neutral (N) position when the clutch/brake pedal is depressed.

- To restart movement, slowly release parking brake and clutch/brake pedal.
- Slowly move motion control lever to slowest setting.
- Make all turns slowly.

TO TRANSPORT

When pushing or towing your tractor, be sure to disengage transmission by placing freewheel control in freewheeling position. Freewheel control is located at the rear drawbar of tractor.

- Raise attachment lift to highest position with attachment lift control.
- Pull freewheel control knob out and hold in position by inserting retainer spring into forward hole of control rod.

- Do not push or tow tractor at more than two (2) MPH.
- To reengage transmission, reverse above procedure.

NOTE: To protect hood from damage when transporting your tractor on a truck or a trailer, be sure hood is closed and secured to tractor. Use an appropriate means of tying hood to tractor (rope, cord, etc.).

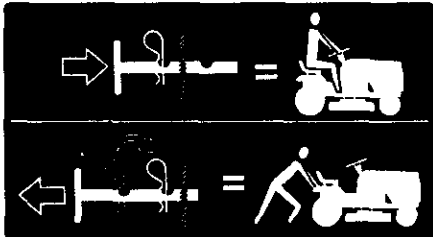

TOWING CARTS AND OTHER ATTACHMENTS

Tow only the attachments that are recommended by and comply with specifications of the manufacturer of your tractor. Use common sense when towing. Too heavy of a load, while on a slope, is dangerous. Tires can lose traction with the ground and cause you to lose control of your tractor.

BEFORE STARTING THE ENGINE CHECK ENGINE OIL LEVEL

- The engine in your tractor has been shipped, from the factory, already filled with summer weight oil.
- Check engine oil with tractor on level ground.
- Remove oil fill cap/dipstick and wipe clean, reinsert the dipstick and screw cap tight, wait for a few seconds, remove and read oil level. If necessary, add oil until "FULL" mark on dipstick is reached. Do not overfill.
- For cold weather operation you should change oil for easier starting (See "OIL VISCOSITY CHART" in the Maintenance section of this manual).
- To change engine oil, see the Maintenance section in this manual.

ADD GASOLINE

- Fill fuel tank. Use fresh, clean, regular unleaded gasoline with a minimum of 87 octane. (Use of leaded gasoline will increase carbon and lead oxide deposits and reduce valve life). Do not mix oil with gasoline.

Purchase fuel in quantities that can be used within 30 days to assure fuel freshness.

IMPORTANT: When operating in temperatures below 32°F(0°C), use fresh, clean winter grade gasoline to help insure good cold weather starting.

▲WARNING: Experience indicates that alcohol blended fuels (called gasohol or using ethanol or methanol) can attract moisture which leads to separation and formation of acids during storage. Acidic gas can damage the fuel system of an engine while in storage. To avoid engine problems, the fuel system should be emptied before storage of 30 days or longer. Drain the gas tank, start the engine and let it run until the fuel lines and carburetor are empty. Use fresh fuel next season. See Storage Instructions for additional information. Never use engine or carburetor cleaner products in the fuel tank or permanent damage may occur.

▲CAUTION: Fill to bottom of gas tank filler neck. Do not overfill. Wipe off any spilled oil or fuel. Do not store, spill or use gasoline near an open flame.

TO START ENGINE

When starting the engine for the first time or if the engine has run out of fuel, it will take extra cranking time to move fuel from the tank to the engine.

- Be sure freewheel control is in the transmission engaged position.
- Sit on seat in operating position, depress clutch/brake pedal and set parking brake.
- Place motion control lever in neutral (N) position.
- Move attachment clutch to "DISENGAGED" position.
- Move throttle control to fast position
- Pull choke control out for a cold engine start attempt. For a warm engine start attempt the choke control may not be needed.

NOTE: Before starting, read the warm and cold starting procedures below.

- Insert key into ignition and turn key clockwise to "START" position and release key as soon as engine starts. Do not run starter continuously for more than fifteen seconds per minute. If the engine does not start after several attempts, push choke control in, wait a few minutes and try again. If engine still does not start, pull the choke control out and retry.

WARM WEATHER STARTING (50° F AND ABOVE)

- When engine starts, slowly push choke control in until the engine begins to run smoothly. If the engine starts to run roughly, pull the choke control out slightly for a few seconds and then continue to push the control in slowly.

- The attachments and ground drive can now be used. If the engine does not accept the load, restart the engine and allow it to warm up for one minute using the choke as described above.

COLD WEATHER STARTING (50° F AND BELOW)

- When engine starts, slowly push choke control in until the engine begins to run smoothly. Continue to push the choke control in small steps allowing the engine to accept small changes in speed and load, until the choke control is fully in. If the engine starts to run roughly, pull the choke control out slightly for a few seconds and then continue to push the control in slowly. This may require an engine warm-up period from several seconds to several minutes, depending on the temperature.

AUTOMATIC TRANSMISSION WARM-UP

- Before driving the unit in cold weather, the transmission should be warmed up as follows:
 - Be sure the tractor is on level ground.
 - Place the motion control lever in neutral. Release the parking brake and let the clutch/brake slowly return to operating position.
 - Allow one minute for transmission to warm up. This can be done during the engine warm up period.
- The attachments can be used during the engine warm-up period after the transmission has been warmed up and may require the choke control be pulled out slightly.

NOTE: A high altitude (above 3000 feet) or in cold temperatures (below 32 F) the carburetor fuel mixture may need to be adjusted for best engine performance. See "TO ADJUST CARBURETOR" in the Service and Adjustments section of this manual.

PURGE TRANSMISSION

▲ CAUTION: Never engage or disengage freewheel lever while the engine is running.

To ensure proper operation and performance, it is recommended that the transmission be purged before operating tractor for the first time. This procedure will remove any trapped air inside the transmission which may have developed during shipping of your tractor.

IMPORTANT: Should your transmission require removal for service or replacement, it should be purged after reinstallation before operating the tractor.

- Place tractor safely on level surface with engine off and parking brake set.
- Disengage transmission by placing freewheel control in freewheeling position (See "TO TRANSPORT" in this section of manual).
- Sitting in the tractor seat, start engine. After the engine is running, move throttle control to slow position. With motion control lever in neutral (N) position, slowly disengage clutch/brake pedal.
- Move motion control lever to full forward position and hold for five (5) seconds. Move lever to full reverse position and hold for five (5) seconds. Repeat this procedure three (3) times.

NOTE: During this procedure there will be no movement of drive wheels. The air is being removed from hydraulic drive system.

- Move motion control lever to neutral (N) position. Shut off engine and set parking brake.
- Engage transmission by placing freewheel control in driving position (See "TO TRANSPORT" in this section of manual).
- Sitting in the tractor seat, start engine. After the engine is running, move throttle control to half (1/2) speed. With motion control lever in neutral (N) position, slowly disengage clutch/brake pedal.
- Slowly move motion control lever forward; after the tractor moves approximately five (5) feet, slowly move motion control lever to reverse position. After the tractor moves approximately five (5) feet return the motion control lever to the neutral (N) position. Repeat this procedure with the motion control lever three (3) times.
- Your tractor is now purged and ready for normal operation.

MOWING TIPS

- Mower should be properly leveled for best mowing performance. See "TO LEVEL MOWER HOUSING" in the Service and Adjustments section of this manual.
- The left hand side of mower should be used for trimming.
- Drive so that clippings are discharged onto the area that has been cut. Have the cut area to the right of the tractor. This will result in a more even distribution of clippings and more uniform cutting.
- When mowing large areas, start by turning to the right so that clippings will discharge away from shrubs, fences, driveways, etc. After one or two rounds, mow in the opposite direction making left hand turns until finished.
- If grass is extremely tall, it should be mowed twice to reduce load and possible fire hazard from dried clippings. Make first cut relatively high; the second to the desired height.
- Do not mow grass when it is wet. Wet grass will plug mower and leave undesirable clumps. Allow grass to dry before mowing.
- **Always operate engine at full throttle when mowing** to assure better mowing performance and proper discharge of material. Regulate ground speed by selecting a low enough gear to give the mower the best cutting performance as well as the quality of cut desired.
- When operating attachments, select a ground speed that will suit the terrain and give best performance of the attachment being used.

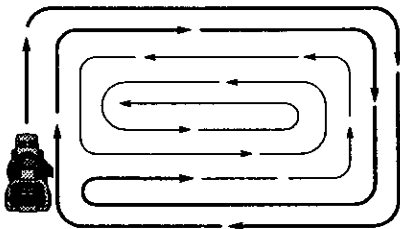

MULCHING MOWING TIPS

IMPORTANT: For best performance, keep mower housing free of built-up grass and trash. Clean after each use.

- The special mulching blade will recut the grass clippings many times and reduce them in size so that as they fall onto the lawn they will disperse into the grass and not be noticed. Also, the mulched grass will biodegrade quickly to provide nutrients for the lawn. Always mulch with your highest engine (blade) speed as this will provide the best recutting action of the blades.
- Avoid cutting your lawn when it is wet. Wet grass tends to form clumps and interferes with the mulching action. The best time to mow your lawn is the early afternoon. At this time the grass has dried and the newly cut area will not be exposed to the direct sun.
- For best results, adjust the mower cutting height so that the mower cuts off only the top one-third of the grass blades. For extremely heavy mulching, reduce your width of cut on each pass and mow slowly.
- Certain types of grass and grass conditions may require that an area be mulched a second time to completely hide the clippings. When doing a second cut, mow across or perpendicular to the first cut path.
- Change your cutting pattern from week to week. Mow north to south one week then change to east to west the next week. This will help prevent matting and graining of the lawn.

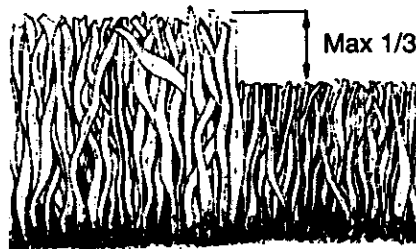

MAINTENANCE

MAINTENANCE SCHEDULE		BEFORE EACH USE EVERY 8 HOURS EVERY 25 HOURS EVERY 50 HOURS EVERY 100 HOURS EVERY SEASON BEFORE STORAGE							SERVICE DATES				
FILL IN DATES AS YOU COMPLETE REGULAR SERVICE													
T R A C T O R	Check Brake Operation	✓	✓										
	Check Tire Pressure	✓	✓										
	Check Operator Presence and Interlock Systems	✓											
	Check for Loose Fasteners	✓					✓ ₇		✓				
	Sharpen/Replace Mower Blades				✓ ₄								
	Lubrication Chart				✓				✓				
	Check Battery Level				✓ ₆								
	Clean Battery and Terminals				✓					✓			
	Check Transaxle Cooling				✓								
	Adjust Blade Belt(s) Tension							✓ ₅					
	Adjust Motion Drive Belt(s) Tension							✓ ₅					
	E N G I N E	Check Engine Oil Level	✓	✓									
Change Engine Oil					✓ _{1,2,3}				✓				
Clean Air Filter					✓ ₂								
Clean Air Screen					✓ ₂								
Inspect Muffler/Spark Arrester						✓							
Replace Oil Filter (If equipped)								✓ _{1,2}					
Clean Engine Cooling Fins								✓ ₂					
Replace Spark Plug								✓	✓				
Replace Air Filter Paper Cartridge								✓ ₂					
Replace Fuel Filter								✓					

- 1 - Change more often when operating under a heavy load or in high ambient temperatures.
 2 - Service more often when operating in dirty or dusty conditions.
 3 - If equipped with oil filter, change oil every 50 hours.
 4 - Replace blades more often when mowing in sandy soil.
 5 - If equipped with adjustable system.
 6 - Not required if equipped with maintenance-free battery.
 7 - Tighten front axle pivot bolt to 35 ft.-lbs. maximum. Do not overtighten.

GENERAL RECOMMENDATIONS

The warranty on this tractor does not cover items that have been subjected to operator abuse or negligence. To receive full value from the warranty, operator must maintain tractor as instructed in this manual. Some adjustments will need to be made periodically to properly maintain your tractor.

All adjustments in the Service and Adjustments section of this manual should be checked at least once each season.

- Once a year you should replace the spark plug, clean or replace air filter, and check blades and belts for wear. A new spark plug and clean air filter assure proper air-fuel mixture and help your engine run better and last longer.

BEFORE EACH USE

- Check engine oil level.
- Check brake operation.
- Check tire pressure.
- Check operator presence and interlock systems for proper operation.
- Check for loose fasteners.

LUBRICATION CHART

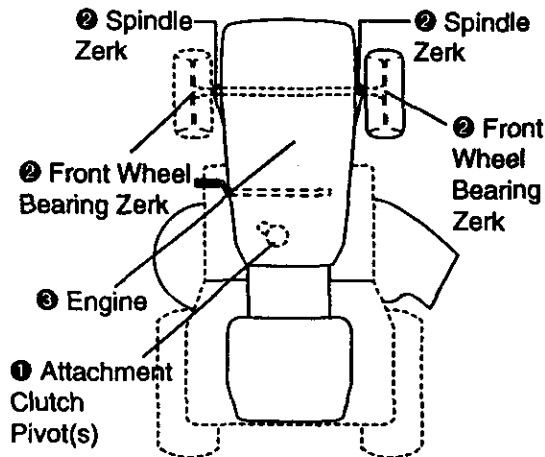

- 1 SAE 30 or 10w30 Motor Oil
- 2 General Purpose Grease
- 3 Refer to Maintenance "Engine" Section

IMPORTANT: Do not oil or grease the pivot points which have special nylon bearings. Viscous lubricants will attract dust and dirt that will shorten the life of the self-lubricating bearings. If you feel they must be lubricated, use only a dry, powdered graphite type lubricant sparingly.

TRACTOR

Always observe safety rules when performing any maintenance.

BRAKE OPERATION

If tractor requires more than six (6) feet stopping distance at high speed in highest gear, then brake must be adjusted. (See "TO ADJUST BRAKE" in the Service and Adjustments section of this manual).

TIRES

- Maintain proper air pressure in all tires (See "PRODUCT SPECIFICATIONS" section of this manual).
- Keep tires free of gasoline, oil, or insect control chemicals which can harm rubber.
- Avoid stumps, stones, deep ruts, sharp objects and other hazards that may cause tire damage.

NOTE: To seal tire punctures and prevent flat tires due to slow leaks, tire sealant may be purchased from your local parts dealer. Tire sealant also prevents tire dry rot and corrosion.

OPERATOR PRESENCE SYSTEM

Be sure that operator presence and interlock systems are working properly. If your tractor does not function as described below, repair the problem immediately.

- The engine should not start unless the clutch/brake pedal is fully depressed and attachment clutch control is in the disengaged position.
- When the engine is running, any attempt by the operator to leave the seat without first setting the parking brake should shut off the engine.
- When the engine is running and the attachment clutch is engaged, any attempt by the operator to leave the seat should shut off the engine.
- The attachment clutch should never operate unless the operator is in the seat.

BLADE CARE

For best results mower blades must be kept sharp. Replace bent or damaged blades.

BLADE REMOVAL

- Raise mower to highest position to allow access to blades.
- Remove hex bolt, lock washer and flat washer securing blade.
- Install new or resharpened blade with trailing edge up towards deck as shown.

IMPORTANT: To ensure proper assembly, center hole in blade must align with star on mandrel assembly.

- Reassemble hex bolt, lock washer and flat washer in exact order as shown.
- Tighten bolt securely (27-35 Ft. Lbs. torque).

IMPORTANT: Blade bolt is grade 8 heat treated.

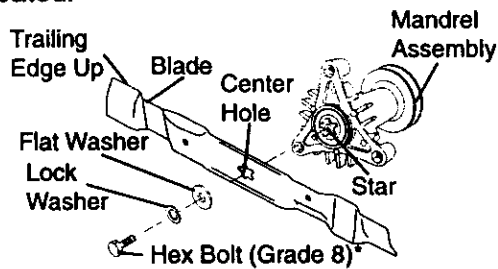

*A Grade 8 heat treated bolt can be identified by six lines on the bolt head.

TO SHARPEN BLADE

NOTE: We do not recommend sharpening blade, but if you do, be sure the blade is balanced.

Care should be taken to keep the blade balanced. An unbalanced blade will cause excessive vibration and eventual damage to mower and engine.

- The blade can be sharpened with a file or on a grinding wheel. Do not attempt to sharpen while it is on the mower.
- To check blade balance, you will need a 5/8" diameter steel bolt, pin, or a cone balancer. (When using a cone balancer, follow the instructions supplied with balancer).

NOTE: Do not use a nail for balancing blade. The lobes of the center hole may appear to be centered, but are not.

- Slide blade onto an unthreaded portion of the steel bolt or pin and hold the bolt or pin parallel with the ground. If blade is balanced, it should remain in a horizontal position. If either end of the blade moves downward, sharpen the heavy end until the blade is balanced.

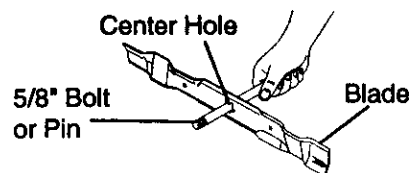

BATTERY

Your tractor has a battery charging system which is sufficient for normal use.

However, periodic charging of the battery with an automotive charger will extend its life.

- Keep battery and terminals clean.
- Keep battery bolts tight.
- Keep small vent holes open.
- Recharge at 6-10 amperes for 1 hour.

NOTE: The original equipment battery on your tractor is maintenance free. Do not attempt to open or remove caps or covers. Adding or checking level of electrolyte is not necessary.

TO CLEAN BATTERY AND TERMINALS
Corrosion and dirt on the battery and terminals can cause the battery to "leak" power.

- Remove terminal guard.
- Disconnect BLACK battery cable first then RED battery cable and remove battery from tractor.
- Rinse the battery with plain water and dry.
- Clean terminals and battery cable ends with wire brush until bright.
- Coat terminals with grease or petroleum jelly.
- Reinstall battery (See "REPLACING BATTERY" in the SERVICE AND ADJUSTMENTS section of this manual).

V-BELTS

Check V-belts for deterioration and wear after 100 hours of operation and replace if necessary. The belts are not adjustable. Replace belts if they begin to slip from wear.

TRANSAXLE COOLING

The transmission fan and cooling fins should be kept clean to assure proper cooling.

Do not attempt to clean fan or transmission while engine is running or while the transmission is hot.

- Inspect cooling fan to be sure fan blades are intact and clean.
- Inspect cooling fins for dirt, grass clippings and other materials. To prevent damage to seals, do not use compressed air or high pressure sprayer to clean cooling fins.

TRANSAXLE PUMP FLUID

The transaxle was sealed at the factory and fluid maintenance is not required for the life of the transaxle. Should the transaxle ever leak or require servicing, contact your nearest authorized service center/department.

ENGINE LUBRICATION

Only use high quality detergent oil rated with API service classification SF, SG, or SH. Select the oil's SAE viscosity grade according to your expected operating temperature.

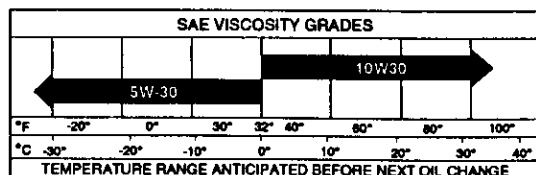

NOTE: Although multi-viscosity oils (5W30, 10W30 etc.) improve starting in cold weather, these multi-viscosity oils will result in increased oil consumption when used above 32°F. Check your engine oil level more frequently to avoid possible engine damage from running low on oil.

Change the oil after every 50 hours of operation or at least once a year if the tractor is not used for 50 hours in one year.

Check the crankcase oil level before starting the engine and after each eight (8) hours of operation. Tighten oil fill cap/dipstick securely each time you check the oil level.

TO CHANGE ENGINE OIL

Determine temperature range expected before oil change. All oil must meet API service classification SF, SG or SH.

- Be sure tractor is on level surface.
- Oil will drain more freely when warm.
- Catch oil in a suitable container.
- Remove oil fill cap/dipstick. Be careful not to allow dirt to enter the engine when changing oil.
- Remove drain plug.
- After oil has drained completely, replace oil drain plug and tighten securely.
- Refill engine with oil through oil fill dipstick tube. Pour slowly. Do not overfill. For approximate capacity see "PRODUCT SPECIFICATIONS" section of this manual.
- Use gauge on oil fill cap/dipstick for checking level. Be sure dipstick cap is tightened securely for accurate reading. Keep oil at "FULL" line on dipstick.

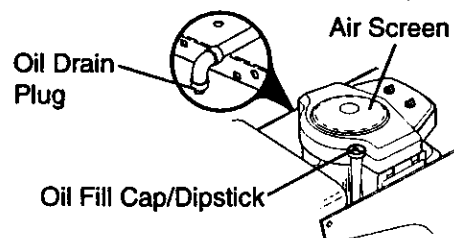

CLEAN AIR SCREEN

Air screen must be kept free of dirt and chaff to prevent engine damage from overheating. Clean with a wire brush or compressed air to remove dirt and stubborn dried gum fibers.

ENGINE COOLING FINS

Remove any dust, dirt or oil from engine cooling fins to prevent engine damage from overheating.

- Remove oil fill cap/dipstick.
- Remove hex bolts from blower housing and lift housing off engine.
- Cover oil fill opening to prevent entry of dirt.

- Use compressed air or stiff bristle brush to thoroughly clean engine cooling fins.
- To reassemble, reverse above procedure.

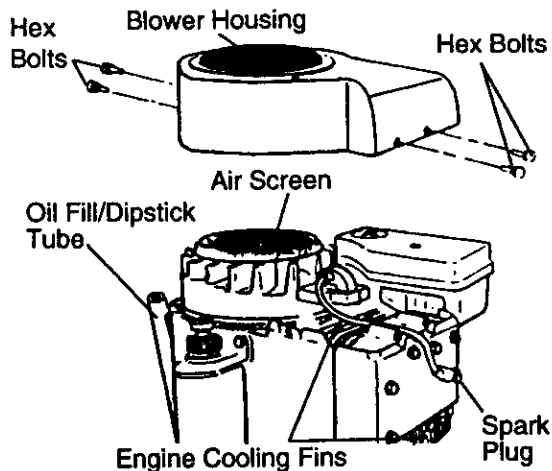

AIR FILTER

Your engine will not run properly using a dirty air filter. Clean the foam pre-cleaner after every 25 hours of operation or every season. Service paper cartridge every 100 hours of operation or every season, whichever occurs first. Service air cleaner more often under dusty conditions.

- Remove knobs and cover.

TO SERVICE PRE-CLEANER

- Wash it in liquid detergent and water.
- Squeeze it dry in a clean cloth.
- Saturate it in engine oil. Wrap it in clean, absorbent cloth and squeeze to remove excess oil.
- If very dirty or damaged, replace pre-cleaner.

TO SERVICE CARTRIDGE

- Clean cartridge by tapping gently on flat surface. If very dirty or damaged, replace cartridge.
- Reinstall pre-cleaner cartridge, cover and secure with knobs.

IMPORTANT: Petroleum solvents, such as kerosene, are not to be used to clean the cartridge. They may cause deterioration of the cartridge. Do not oil cartridge. Do not use pressurized air to clean or dry cartridge.

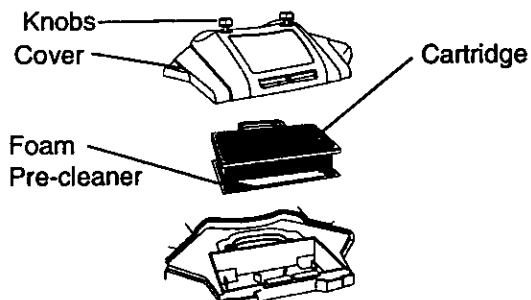

ENGINE OIL FILTER

Replace the engine oil filter every season or every other oil change if the tractor is used more than 100 hours in one year.

- Unscrew old filter by turning counter-clockwise. Use a suitable container to catch oil.
- Apply a thin coating of new engine oil to rubber gasket on replacement oil filter.
- Install replacement oil filter by turning clockwise until rubber gasket contacts mounting surface, then tighten filter an additional 1/2 to 3/4 turn.
- Fill crankcase with new oil (See "TO CHANGE ENGINE OIL" in this section of this manual). For approximate capacity see "PRODUCT SPECIFICATIONS" section of this manual.
- Start engine and check for oil leaks. Correct any leaks before placing engine into full operation.

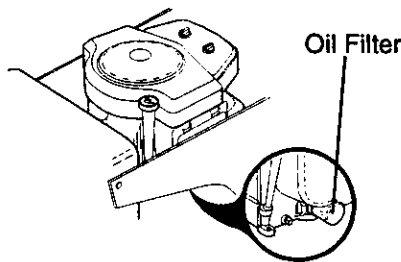

MUFFLER

Inspect and replace corroded muffler and spark arrester (if equipped) as it could create a fire hazard and/or damage.

SPARK PLUGS

Replace spark plugs at the beginning of each mowing season or after every 100 hours of operation, whichever occurs first. Spark plug type and gap setting are shown in "PRODUCT SPECIFICATIONS" section of this manual.

IN-LINE FUEL FILTER

The fuel filter should be replaced once each season. If fuel filter becomes clogged, obstructing fuel flow to carburetor, replacement is required.

- With engine cool, remove filter and plug fuel line sections.
- Place new fuel filter in position in fuel line with arrow pointing towards carburetor.
- Be sure there are no fuel line leaks and clamps are properly positioned.
- Immediately wipe up any spilled gasoline.

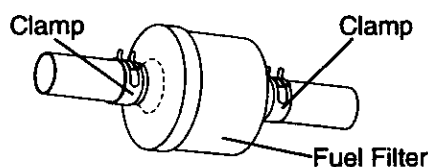

CLEANING

- Clean engine, battery, seat, finish, etc. of all foreign matter.
- Keep finished surfaces and wheels free of all gasoline, oil, etc.
- Protect painted surfaces with automotive type wax.

We do not recommend using a garden hose to clean your tractor unless the electrical system, muffler, air filter and carburetor are covered to keep water out. Water in engine can result in a shortened engine life.

SERVICE AND ADJUSTMENTS

▲ CAUTION: Before performing any service or adjustments:

- Depress clutch/brake pedal fully and set parking brake.
- Place motion control lever in neutral (N) position.
- Place attachment clutch in "DISENGAGED" position.
- Turn ignition key "OFF" and remove key.
- Make sure the blades and all moving parts have completely stopped.
- Disconnect spark plug wire from spark plug and place wire where it cannot come in contact with plug.

TRACTOR

TO REMOVE MOWER

- Place attachment clutch in "DISENGAGED" position.
- Turn height adjustment knob to lowest setting.
- Lower mower to its lowest position.
- Remove retainer spring holding anti-swaybar to chassis bracket and disengage anti-swaybar from bracket.
- Remove retainer springs from suspension arms at deck and disengage arms from deck.
- Raise attachment lift to its highest position.

- Remove two retainer springs from each front link and remove links.
- Slide mower forward and remove belt from electric clutch pulley.
- Slide mower out from under right side of tractor.

IMPORTANT: If an attachment other than the mower deck is to be mounted on the tractor, remove the front links.

TO INSTALL MOWER

Follow procedure described in "INSTALL MOWER AND DRIVE BELT" in the Assembly section of this manual.

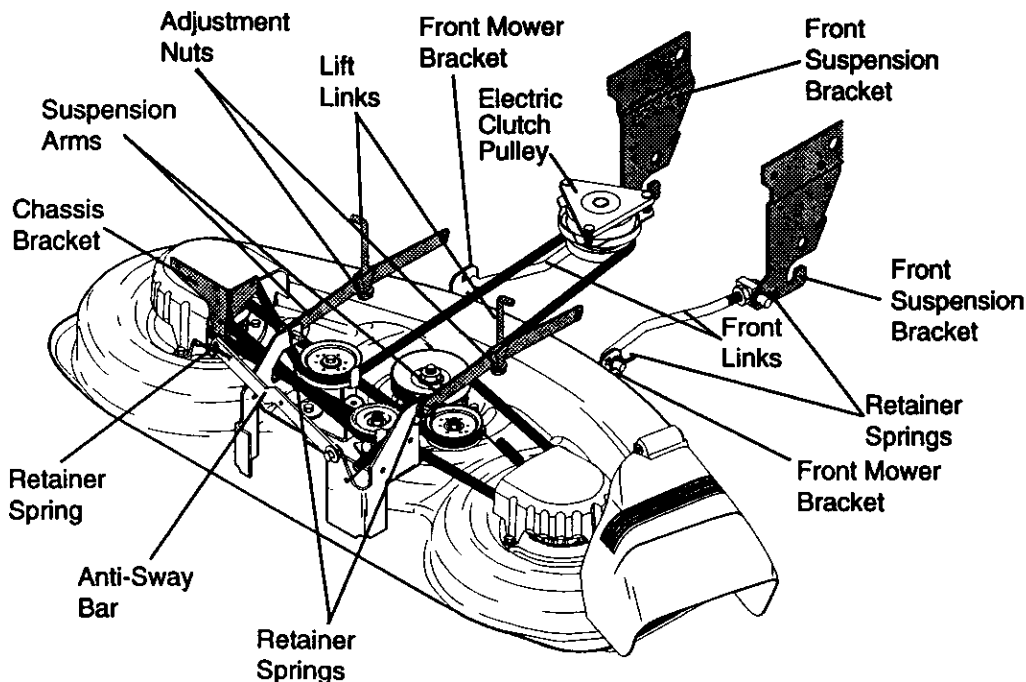

TO LEVEL MOWER HOUSING

Adjust the mower while tractor is parked on level ground or driveway. Make sure tires are properly inflated (See "PRODUCT SPECIFICATIONS"). If tires are over or underinflated, you will not properly adjust your mower.

SIDE-TO-SIDE ADJUSTMENT

- Raise mower to its highest position.
- At the midpoint of both sides of mower, measure height from bottom edge of mower to ground. Distance "A" on both sides of mower should be the same or within 1/4" of each other.
- If adjustment is necessary, make adjustment on one side of mower only.
- To raise one side of mower, tighten lift link adjustment nut on that side.
- To lower one side of mower, loosen lift link adjustment nut on that side.

NOTE: Each full turn of adjustment nut will change mower height about 1/8".

- Recheck measurements after adjusting.

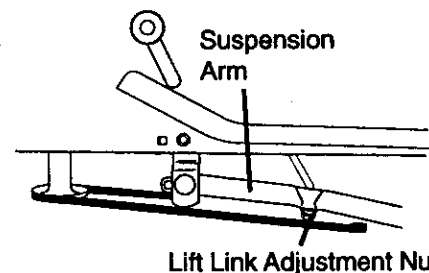
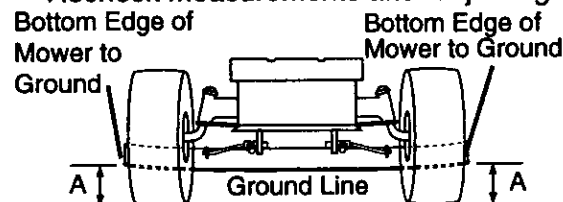

- If links are not equal in length, adjust one link to same length as other link.
- To lower front of mower loosen nut "E" on both front links an equal number of turns.
- When distance "D" is 1/8" to 1/2" lower at front than rear, tighten nuts "F" against trunnion on both front links.
- To raise front of mower, loosen nut "F" from trunnion on both front links. Tighten nut "E" on both front links an equal number of turns.
- When distance "D" is 1/8" to 1/2" lower at front than rear, tighten nut "F" against trunnion on both front links.
- Recheck side-to-side adjustment.

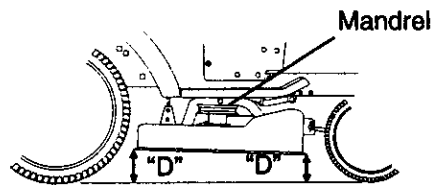

Both Front Links Should be Equal in Length

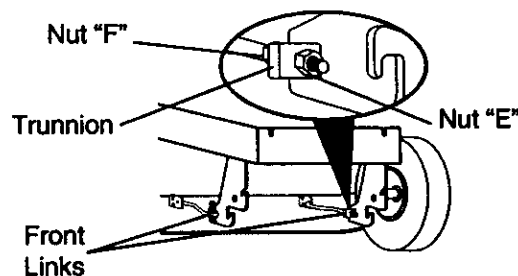
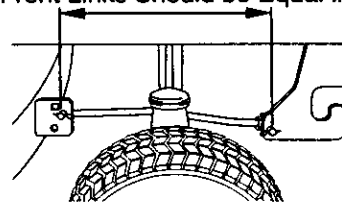

TO REPLACE MOWER DRIVE BELT

MOWER DRIVE BELT REMOVAL

- Park tractor on a level surface. Engage parking brake.
- Remove screws from left hand mandrel cover and remove cover.
- Roll belt over the top of left hand mandrel pulley.
- Remove belt from electric clutch pulley.
- Remove belt from idler pulleys.
- Remove any dirt or grass clippings which may have accumulated around mandrels and entire upper deck surface.
- Check primary idler arm and two idlers to see that they rotate freely.
- Be sure spring is securely hooked to primary idler arm and bolt in mower housing.

FRONT-TO-BACK ADJUSTMENT

IMPORTANT: Deck must be level side-to-side. If the following front-to-back adjustment is necessary, be sure to adjust both front links equally so mower will stay level side-to-side.

To obtain the best cutting results, the mower housing should be adjusted so that the front is approximately 1/8" to 1/2" lower than the rear when the mower is in its highest position.

Check adjustment on right side of tractor. Measure distance "D" directly in front and behind the mandrel at bottom edge of mower housing as shown.

- Before making any necessary adjustments, check that both front links are equal in length. Both links should be approximately 10-3/8".

MOWER DRIVE BELT INSTALLATION

- Install belt in both idlers. Make sure belt is in both belt keepers at the idlers as shown.
- Install new belt onto electric clutch pulley.
- Roll belt into upper groove of left hand mandrel pulley.
- Carefully check belt routing making sure belt is in the grooves correctly and inside belt keepers.
- Reassemble left hand mandrel cover.

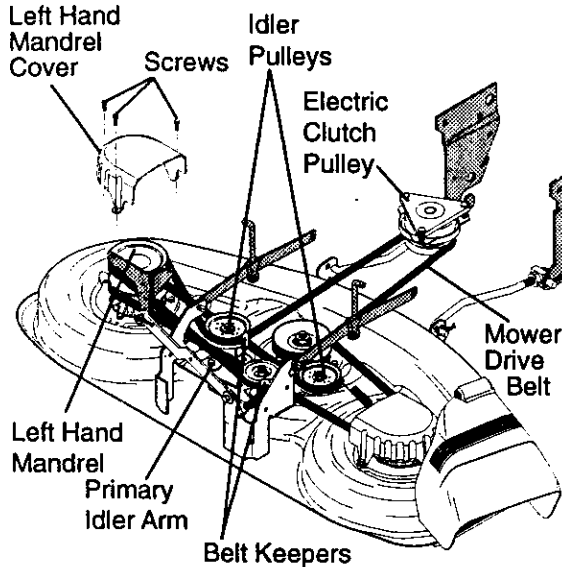

- Roll belt over right hand mandrel pulley. Make sure belt is in all grooves properly.
- Reconnect spring to bolt in mower housing and reinstall right hand mandrel cover.
- Reinstall mower to tractor (See "INSTALL MOWER AND DRIVE BELT" in the Assembly section of this manual).
- Reassemble mower drive belt (See "TO REPLACE MOWER DRIVE BELT" in this section of this manual).

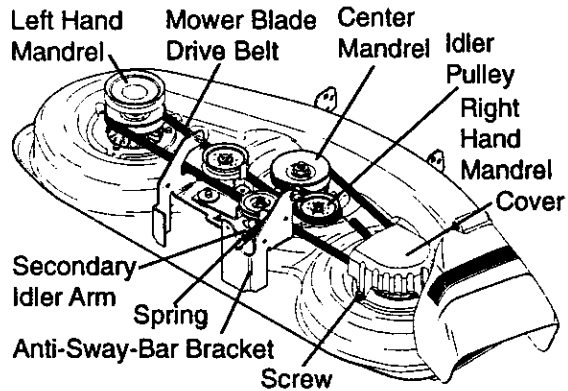

TO ADJUST BRAKE

Your tractor is equipped with an adjustable brake system which is mounted on the side of the transaxle.

If tractor requires more than six (6) feet stopping distance at high speed in highest gear, then brake must be adjusted.

- Depress clutch/brake pedal and engage parking brake.
- Measure distance between brake operating arm and nut "A" on brake rod.
- If distance is other than 1-9/16", loosen jam nut and turn nut "A" until distance becomes 1-9/16". Retighten jam nut against nut "A".
- Road test tractor for proper stopping distance as stated above. Readjust if necessary. If stopping distance is still greater than six (6) feet in highest gear, further maintenance is necessary. Contact your nearest authorized service center/department.

TO REPLACE MOWER BLADE DRIVE BELT

Park the tractor on level surface. Engage parking brake.

- Remove mower drive belt (See "TO REPLACE MOWER DRIVE BELT" in this section of this manual).
- Remove mower (See "TO REMOVE MOWER" in this section of this manual).
- Remove four screws from right hand mandrel cover and remove cover. Unhook spring from bolt on mower housing.
- Carefully roll belt off right hand mandrel pulley.
- Remove belt from center mandrel pulley, idler pulley, and left hand mandrel pulley.
- Remove any dirt or grass which may have accumulated around mandrels and entire upper deck surface.
- Check secondary idler arm and idler to see that they rotate freely.
- Be sure spring is hooked in secondary idler arm and sway-bar bracket.
- Install new belt in lower groove of left hand mandrel pulley, idler pulley, and center mandrel pulley as shown.

With Parking Brake "Engaged"

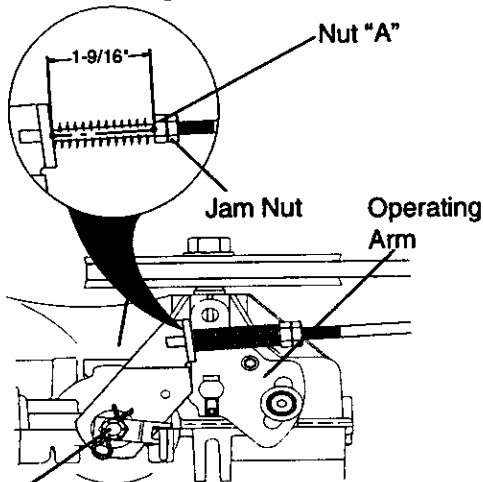

Do Not touch this nut. If further brake adjustment is necessary contact your nearest authorized service center/department

TO REPLACE MOTION DRIVE BELT

Park the tractor on level surface. Engage parking brake. For assistance, there is a belt installation guide decal on bottom side of left footrest.

- Remove mower (See "TO REMOVE MOWER" in this section of this manual.)
- Disconnect clutch wire harness.
- Remove clutch locator.
- Remove belt from stationary idler and clutching idler.
- Pull belt slack toward rear of tractor. Carefully remove belt upwards from transmission input pulley and over cooling fan blades.
- Pull belt toward front of tractor and remove downwards from around electric clutch.
- Install new belt by reversing above procedure.

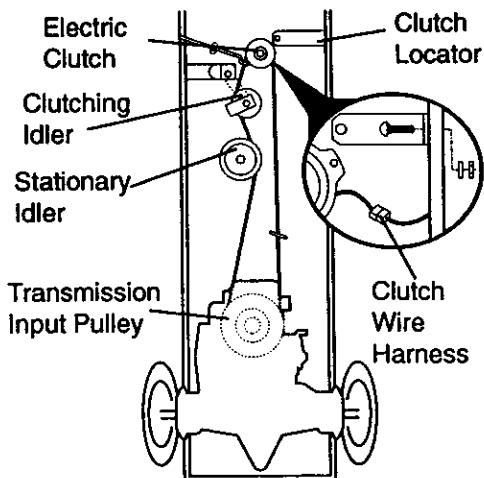

TRANSAXLE MOTION CONTROL LEVER NEUTRAL ADJUSTMENT

The motion control lever has been preset at the factory and adjustment should not be necessary.

- Loosen adjustment bolt in front of the right rear wheel, and lightly tighten.
- Start engine and move motion control lever until tractor does not move forward or backward.
- Hold motion control lever in that position and turn engine off.
- While holding motion control lever in place, loosen the adjustment bolt.
- Move motion control lever to the neutral (N) (lock gate) position.
- Tighten adjustment bolt securely.

NOTE: If additional clearance is needed to get to adjustment bolt, move mower deck height to the lowest position.

After above adjustment is made, if the tractor still creeps forward or backward while motion control lever is in neutral position, follow these steps:

- Loosen the adjustment bolt.
- Move the motion control lever 1/4 to 1/2 inch in the direction it is trying to creep.
- Tighten adjustment bolt securely.
- Start engine and test.
- If tractor still creeps, repeat above steps until satisfied.

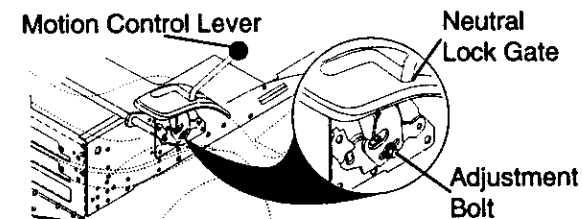

TRANSMISSION REMOVAL/REPLACEMENT

Should your transmission require removal for service or replacement, it should be purged after reinstallation and before operating the tractor. See "PURGE TRANSMISSION" in the Operation section of this manual.

TO ADJUST STEERING WHEEL ALIGNMENT

If steering wheel crossbars are not horizontal (left to right) when wheels are positioned straight forward, remove steering wheel and reassemble per instructions in the Assembly section of this manual.

FRONT WHEEL TOE-IN/CAMBER

The front wheel toe-in and camber are not adjustable on your tractor. If damage has occurred to affect the front wheel toe-in or camber, contact your nearest authorized service center/department.

TO REMOVE WHEEL FOR REPAIRS

- Block up axle securely.
- Remove axle cover, retaining ring and washers to allow wheel removal (rear wheel contains a square key - Do not lose).
- Repair tire and reassemble.
- On rear wheels only: align grooves in rear wheel hub and axle. Insert square key.
- Replace washers and snap retaining ring securely in axle groove.
- Replace axle cover.

NOTE: To seal tire punctures and prevent flat tires due to slow leaks, tire sealant may be purchased from your local parts dealer. Tire sealant also prevents tire dry rot and corrosion.

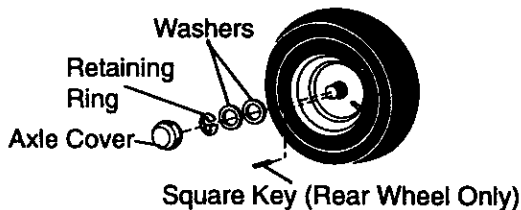

TO START ENGINE WITH A WEAK BATTERY

CAUTION: Lead-acid batteries generate explosive gases. Keep sparks, flame and smoking materials away from batteries. Always wear eye protection when around batteries.

If your battery is too weak to start the engine, it should be recharged. (See "BATTERY" in the MAINTENANCE section of this manual).

If "jumper cables" are used for emergency starting, follow this procedure:

IMPORTANT: Your tractor is equipped with a 12 volt negative grounded system. The other vehicle must also be a 12 volt negative grounded system. Do not use your tractor battery to start other vehicles.

TO ATTACH JUMPER CABLES -

- Connect each end of the RED cable to the POSITIVE (+) terminal of each battery, taking care not to short against chassis.
- Connect one end of the BLACK cable to the NEGATIVE (-) terminal of fully charged battery.
- Connect the other end of the BLACK cable to good CHASSIS GROUND, away from fuel tank and battery.

TO REMOVE CABLES, REVERSE ORDER -

- BLACK cable first from chassis and then from the fully charged battery.
- RED cable last from both batteries.

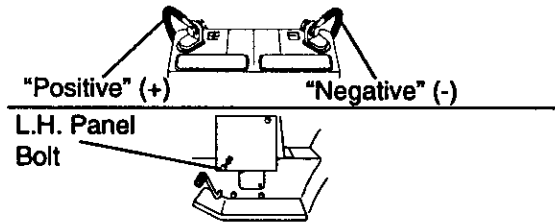

REPLACING BATTERY

CAUTION: Do not short battery terminals by allowing a wrench or any other object to contact both terminals at the same time. Before connecting battery, remove metal bracelets, wristwatch bands, rings, etc.

Positive terminal must be connected first to prevent sparking from accidental grounding.

- Lift hood to raised position.
- Remove terminal guard.
- Disconnect BLACK battery cable then RED battery cable and carefully remove battery from tractor.
- Install new battery with terminals in same position as old battery.
- Reinstall terminal guard.
- First connect RED battery cable to positive (+) battery terminal with hex bolt and keps nut as shown. Tighten securely.
- Connect BLACK grounding cable to negative (-) battery terminal with remaining hex bolt and keps nut. Tighten securely.
- Close terminal access doors.
- Close hood.

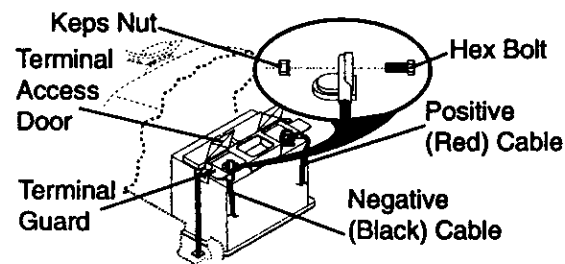

TO REPLACE HEADLIGHT BULB

- Raise hood.
- Pull bulb holder out of the hole in the backside of the grill.
- Replace bulb in holder and push bulb holder securely back into the hole in the backside of the grill.
- Close hood.

INTERLOCKS AND RELAYS

Loose or damaged wiring may cause your tractor to run poorly, stop running, or prevent it from starting.

- Check wiring. See electrical wiring diagram in the Repair Parts section.

TO REPLACE FUSE

Replace with 30 amp automotive-type plug-in fuse. The fuse holder is located behind the dash.

TO REMOVE HOOD AND GRILL ASSEMBLY

- Raise hood.
- Unsnap headlight wire connector.
- Stand in front of tractor. Grasp hood at sides, tilt toward engine and lift off of tractor.
- To replace, reverse above procedure.

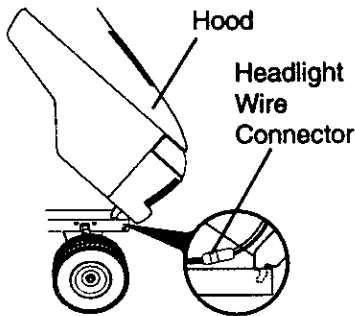

ENGINE

Maintenance, repair, or replacement of the emission control devices and systems, which are being done at the customer's expense, may be performed by any non-road engine repair establishment or individual. Warranty repairs must be performed by an authorized engine manufacturer's service outlet.

TO ADJUST THROTTLE CONTROL CABLE

The throttle control has been preset at the factory and adjustment should not be necessary. Check adjustment as described below before loosening cable. If adjustment is necessary, proceed as follows:

- With engine not running, move throttle control lever to fast position.
- Check that swivel is against stop. If it is not, loosen cable clamp screw and pull cable back until swivel is against stop. Tighten cable clamp screw securely.

TO ADJUST CHOKE CONTROL

The choke control has been preset at the factory and adjustment should not be necessary. Check adjustment as described below before loosening cable. If adjustment is necessary, proceed as follows:

- With engine not running, move choke control (located on dash panel) to full choke position.
- Loosen knob and remove cover assembly

bly from air cleaner.

- Choke should be closed. If it is not, loosen casing clamp screw and move choke cable until choke is completely closed. Tighten casing clamp screw securely.
- Replace air cleaner cover assembly and tighten knob.

TO ADJUST CARBURETOR

Your carburetor is not adjustable. If your engine does not operate properly due to suspected carburetor problems, take your tractor to an authorized service center for repair and/or adjustment.

High speed stop is factory adjusted. Do not adjust - damage may result.

IMPORTANT: Never tamper with the engine governor, which is factory set for proper engine speed. Overspeeding the engine above the factory high speed setting can be dangerous. If you think the engine-governed high speed needs adjusting, contact your nearest AUTHORIZED service center/department, which has proper equipment and experience to make any necessary adjustments.

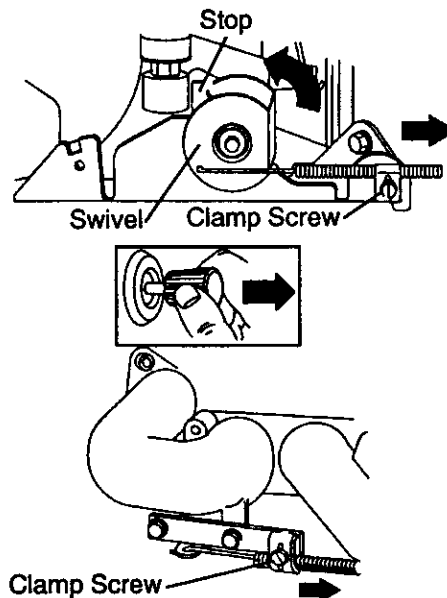

STORAGE

Immediately prepare your tractor for storage at the end of the season or if the tractor will not be used for 30 days or more.

▲ CAUTION: Never store the tractor with gasoline in the tank inside a building where fumes may reach an open flame or spark. Allow the engine to cool before storing in any enclosure.

TRACTOR

Remove mower from tractor for winter storage. This will allow you to clean it thoroughly. Remove all dirt, grease, leaves, etc. Store in a clean, dry area.

- Clean entire tractor (See "CLEANING" in the Maintenance section of this manual).
- Inspect and replace belts, if necessary (See belt replacement instructions in the Service and Adjustments section of this manual).
- Lubricate as shown in the Maintenance section of this manual.
- Be sure that all nuts, bolts and screws are securely fastened. Inspect moving parts for damage, breakage and wear. Replace if necessary.
- Touch up all rusted or chipped paint surfaces; sand lightly before painting.

BATTERY

- Fully charge the battery for storage.
- After a period of time in storage, battery may require recharging.
- To help prevent corrosion and power leakage during long periods of storage, battery cables should be disconnected and battery cleaned thoroughly (see "TO CLEAN BATTERY AND TERMINALS" in the Maintenance section of this manual).
- After cleaning, leave cables disconnected and place cables where they cannot come in contact with battery terminals.
- If battery is removed from tractor for storage, do not store battery directly on concrete or damp surfaces.

ENGINE

FUEL SYSTEM

IMPORTANT: It is important to prevent gum deposits from forming in essential fuel system parts such as carburetor, fuel filter, fuel hose, or tank during storage.

Also, experience indicates that alcohol blended fuels (called gasohol or using ethanol or methanol) can attract moisture which leads to separation and formation of acids during storage. Acidic gas can damage the fuel system of an engine while in storage.

- Drain the fuel tank.
- Start the engine and let it run until the fuel lines and carburetor are empty.
- Never use engine or carburetor cleaner products in the fuel tank or permanent damage may occur.
- Use fresh fuel next season.

NOTE: Fuel stabilizer is an acceptable alternative in minimizing the formation of fuel gum deposits during storage. Add stabilizer to gasoline in fuel tank or storage container. Always follow the mix ratio found on stabilizer container. Run engine at least 10 minutes after adding stabilizer to allow the stabilizer to reach the carburetor. Do not drain the gas tank and carburetor if using fuel stabilizer.

ENGINE OIL

Drain oil (with engine warm) and replace with clean engine oil. (See "ENGINE" in the Maintenance section of this manual).

CYLINDER (S)

- Remove spark plug(s).
- Pour one ounce of oil through spark plug hole(s) into cylinder(s).
- Turn ignition key to "START" position for a few seconds to distribute oil.
- Replace with new spark plug(s).

OTHER

- Do not store gasoline from one season to another.
- Replace your gasoline can if it starts to rust. Rust and/or dirt in your gasoline will cause problems.
- If possible, store your tractor indoors and cover it to give protection from dust and dirt.
- Cover your tractor with a suitable protective cover that does not retain moisture. Do not use plastic. Plastic cannot breathe, which allows condensation to form and cause your tractor to rust.

IMPORTANT: Never cover tractor while engine and exhaust areas are still warm.

TROUBLESHOOTING CHART

PROBLEM	CAUSE	CORRECTION
Will not start	<ul style="list-style-type: none"> • Out of fuel. • Engine not "CHOKED" properly. • Engine flooded. • Bad spark plug. • Dirty air filter. • Dirty fuel filter. • Water in fuel. • Loose or damaged wiring. • Carburetor out of adjustment. • Engine valves out of adjustment. 	<ul style="list-style-type: none"> • Fill fuel tank. • See "TO START ENGINE" in Operation section. • Wait several minutes before attempting to start. • Replace spark plug. • Clean/replace air filter. • Replace fuel filter. • Drain fuel tank and carburetor, refill tank with fresh gasoline and replace fuel filter. • Check all wiring. • See "To Adjust Carburetor" in Service and Adjustments section. • Contact an authorized service center.
Hard to start	<ul style="list-style-type: none"> • Dirty air filter. • Bad spark plug. • Weak or dead battery. • Dirty fuel filter. • Stale or dirty fuel. • Loose or damaged wiring. • Carburetor out of adjustment. • Engine valves out of adjustment. 	<ul style="list-style-type: none"> • Clean/replace air filter. • Replace spark plug. • Recharge or replace battery. • Replace fuel filter. • Drain fuel tank and refill with fresh gasoline. • Check all wiring. • See "To Adjust Carburetor" in Service and Adjustments section. • Contact an authorized service center.
Engine will not turn over	<ul style="list-style-type: none"> • Clutch/brake pedal not depressed. • Attachment clutch is engaged. • Weak or dead battery. • Blown fuse. • Corroded battery terminals. • Loose or damaged wiring. • Faulty ignition switch. • Faulty solenoid or starter. • Faulty operator presence switch(es). 	<ul style="list-style-type: none"> • Depress clutch/brake pedal. • Disengage attachment clutch. • Recharge or replace battery. • Replace fuse. • Clean battery terminals. • Check all wiring. • Check/replace ignition switch. • Check/replace solenoid or starter. • Contact an authorized service center.
Engine clicks but will not start	<ul style="list-style-type: none"> • Weak or dead battery. • Corroded battery terminals. • Loose or damaged wiring. • Faulty solenoid or starter. 	<ul style="list-style-type: none"> • Recharge or replace battery. • Clean battery terminals. • Check all wiring. • Check/replace solenoid or starter.
Loss of power	<ul style="list-style-type: none"> • Cutting too much grass/too fast. • Throttle in "CHOKE" position. • Build-up of grass, leaves and trash under mower. • Dirty air filter. • Low oil level/dirty oil. 	<ul style="list-style-type: none"> • Set in "Higher Cut" position/reduce speed. • Adjust throttle control. • Clean underside of mower housing. • Clean/replace air filter. • Check oil level/change oil.

TROUBLESHOOTING CHART

PROBLEM	CAUSE	CORRECTION
Loss of power (cont'd)	<ul style="list-style-type: none"> Faulty spark plug. Dirty fuel filter. Stale or dirty fuel. Water in fuel. Spark plug wire loose. Dirty engine air screen/fins. Dirty/clogged muffler. Loose or damaged wiring. Carburetor out of adjustment. Engine valves out of adjustment. 	<ul style="list-style-type: none"> Clean and regap or change spark plug. Replace fuel filter. Drain fuel tank and refill with fresh gasoline. Drain fuel tank and carburetor, refill tank with fresh gasoline and replace fuel filter. Connect and tighten spark plug wire. Clean engine air screen/fins. Clean/replace muffler. Check all wiring. See "To Adjust Carburetor" in Service and Adjustments section. Contact an authorized service center.
Excessive vibration	<ul style="list-style-type: none"> Worn, bent or loose blade. Bent blade mandrel. Loose/damaged part(s). 	<ul style="list-style-type: none"> Replace blade. Tighten blade bolt. Replace blade mandrel. Tighten loose part(s). Replace damaged parts.
Engine continues to run when operator leaves seat with attachment clutch engaged	<ul style="list-style-type: none"> Faulty operator-safety presence control system. 	<ul style="list-style-type: none"> Check wiring, switches and connections. If not corrected, contact an authorized service center/department.
Poor cut - uneven	<ul style="list-style-type: none"> Worn, bent or loose blade. Mower deck not level. Buildup of grass, leaves, and trash under mower. Bent blade mandrel. Clogged mower deck vent holes from buildup of grass, leaves, and trash around mandrels. 	<ul style="list-style-type: none"> Replace blade. Tighten blade bolt. Level mower deck. Clean underside of mower housing. Replace blade mandrel. Clean around mandrels to open vent holes.
Mower blades will not rotate	<ul style="list-style-type: none"> Obstruction in clutch mechanism. Worn/damaged mower drive belt. Frozen idler pulley. Frozen blade mandrel. 	<ul style="list-style-type: none"> Remove obstruction. Replace mower drive belt. Replace idler pulley. Replace blade mandrel.
Poor grass discharge	<ul style="list-style-type: none"> Engine speed too slow. Travel speed too fast. Wet grass. Mower deck not level. Low/uneven tire air pressure. Worn, bent or loose blade. 	<ul style="list-style-type: none"> Place throttle control in "FAST" position. Shift to slower speed. Allow grass to dry before mowing. Level mower deck. Check tires for proper air pressure. Replace/sharpen blade. Tighten blade bolt.

TROUBLESHOOTING CHART

PROBLEM	CAUSE	CORRECTION
Poor grass discharge (cont'd)	<ul style="list-style-type: none"> • Buildup of grass, leaves and trash under mower. • Mower drive belt worn. • Blades improperly installed. • Improper blades used. • Clogged mower deck vent holes from buildup of grass, leaves, and trash around mandrels. 	<ul style="list-style-type: none"> • Clean underside of mower housing. • Replace mower drive belt. • Reinstall blades sharp edge down. • Replace with blades listed in this manual. • Clean around mandrels to open vent holes.
Headlight(s) not working (if so equipped)	<ul style="list-style-type: none"> • Switch is "OFF". • Bulb(s) burned out. • Faulty light switch. • Loose or damaged wiring. • Blown fuse. 	<ul style="list-style-type: none"> • Turn switch "ON". • Replace bulb(s). • Check/replace light switch. • Check wiring and connections. • Replace fuse.
Battery will not charge	<ul style="list-style-type: none"> • Bad battery cell(s). • Poor cable connections. • Faulty regulator (if so equipped). • Faulty alternator. 	<ul style="list-style-type: none"> • Replace battery. • Check/clean all connections. • Replace regulator. • Replace alternator.
Loss of drive	<ul style="list-style-type: none"> • Freewheel control in "disengaged" position. • Motion drive belt worn, damaged or broken. • Air trapped in transmission during shipment or servicing. 	<ul style="list-style-type: none"> • Place freewheel control in "engaged" position. • Replace motion drive belt. • Purge transmission.
Engine "backfires" when turning engine "OFF"	<ul style="list-style-type: none"> • Engine throttle control not set at "SLOW" position for 30 seconds before stopping engine. 	<ul style="list-style-type: none"> • Move throttle control to "SLOW" position and allow to idle for 30 seconds before stopping engine.

TRACTOR -- MODEL NUMBER 917.272140

SCHEMATIC

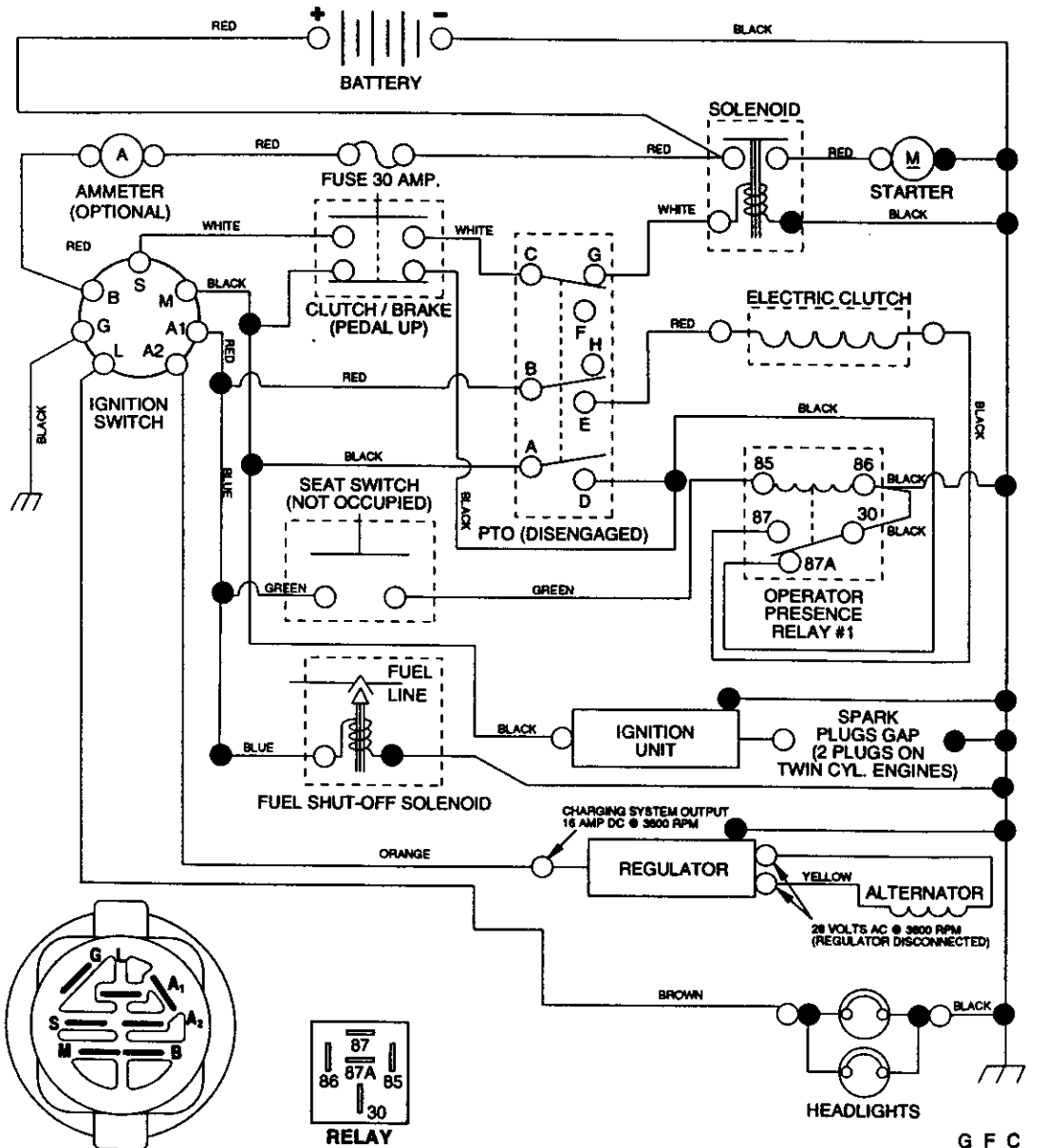

IGNITION SWITCH

POSITION	CIRCUIT	"MAKE"
OFF	M + G + A1	NONE
RUNLIGHT	B + A1	A2 + L
RUN	B + A1	NONE
START	B + S + A1	NONE

WIRING INSULATED CLIPS
 NOTE: IF WIRING INSULATED CLIPS WERE REMOVED FOR SERVICING OF UNIT, THEY SHOULD BE REPLACED TO PROPERLY SECURE YOUR WIRING.

PTO SWITCH

POSITION	CIRCUIT
OFF	C + G, B + H
ON	C + F, B + E, A + D

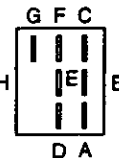

● NON-REMOVABLE CONNECTIONS
 ○ REMOVABLE CONNECTIONS

REPAIR PARTS

TRACTOR -- MODEL NUMBER 917.272140

ELECTRICAL

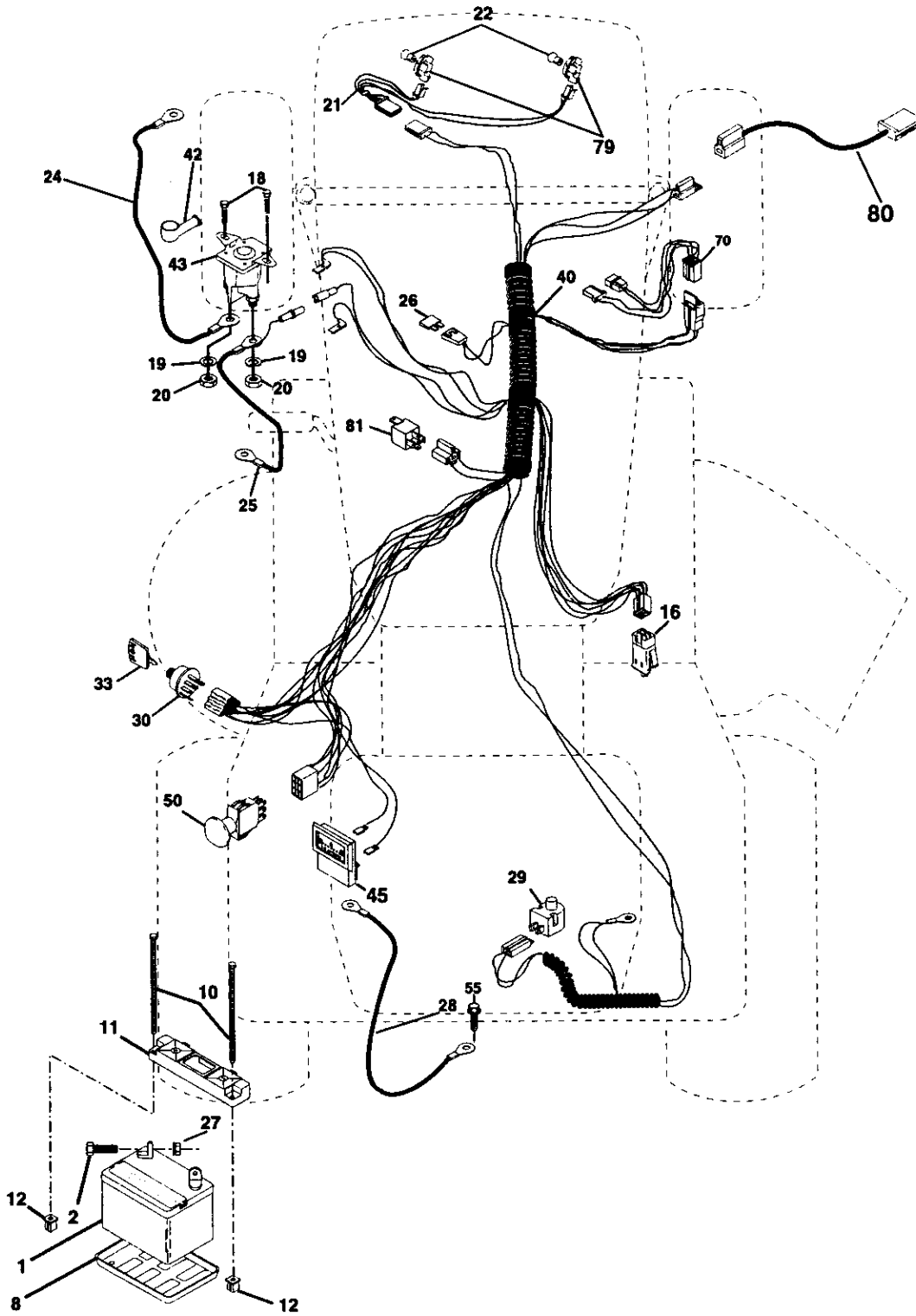

TRACTOR - - MODEL NUMBER 917.272140

ELECTRICAL

KEY	PART	
NO.	NO.	DESCRIPTION
1	163465	Battery
2	74760412	Bolt, Hex 1/4-20 x 3/4
8	7603J	Tray, Battery
10	145211	Bolt, Btr Front 1/4-20 x 7-1/2
11	150109	Holddown Battery Front Mount
12	145769	Nut, Push Nylon Battery Front 1/4
16	153664	Switch Interlock Push-In
18	17720408	Bolt Blk Fin Hex 1/4-20 UNC x 1/2
19	STD551125	Washer, Lock 1/4
20	73350400	Nut, Hex, Jam 1/4-20
21	166184	Harness, Light
22	4152J	Light Bulb
24	8860R	Cable, Battery
25	146148	Cable, Battery
26	166180	Fuse
27	73510400	Nut Keps Hex 1/4-20 Unc
28	145491	Cable, Ground
29	160784	Switch, Seat
30	163968	Switch, Ignition
33	140403	Key, Molded, Craftsman
40	166166	Harness, Ignition
42	131563	Cover, Terminal
43	145673	Solenoid
45	122822X	Ammeter Rectangular 15 Amp
50	154963	Switch Pto 3 Pdt Red Delta 96
55	17490508	Screw Thdrol 5/16-18 x 1/2
70	166668	Harness Engine
79	163996	Socket, Light Bulb
80	146685	Harness Clutch Evx
81	109748X	Relay Asm

NOTE: All component dimensions given in U.S. inches
1 inch = 25.4 mm

TRACTOR - - MODEL NUMBER 917.272140
CHASSIS AND ENCLOSURES

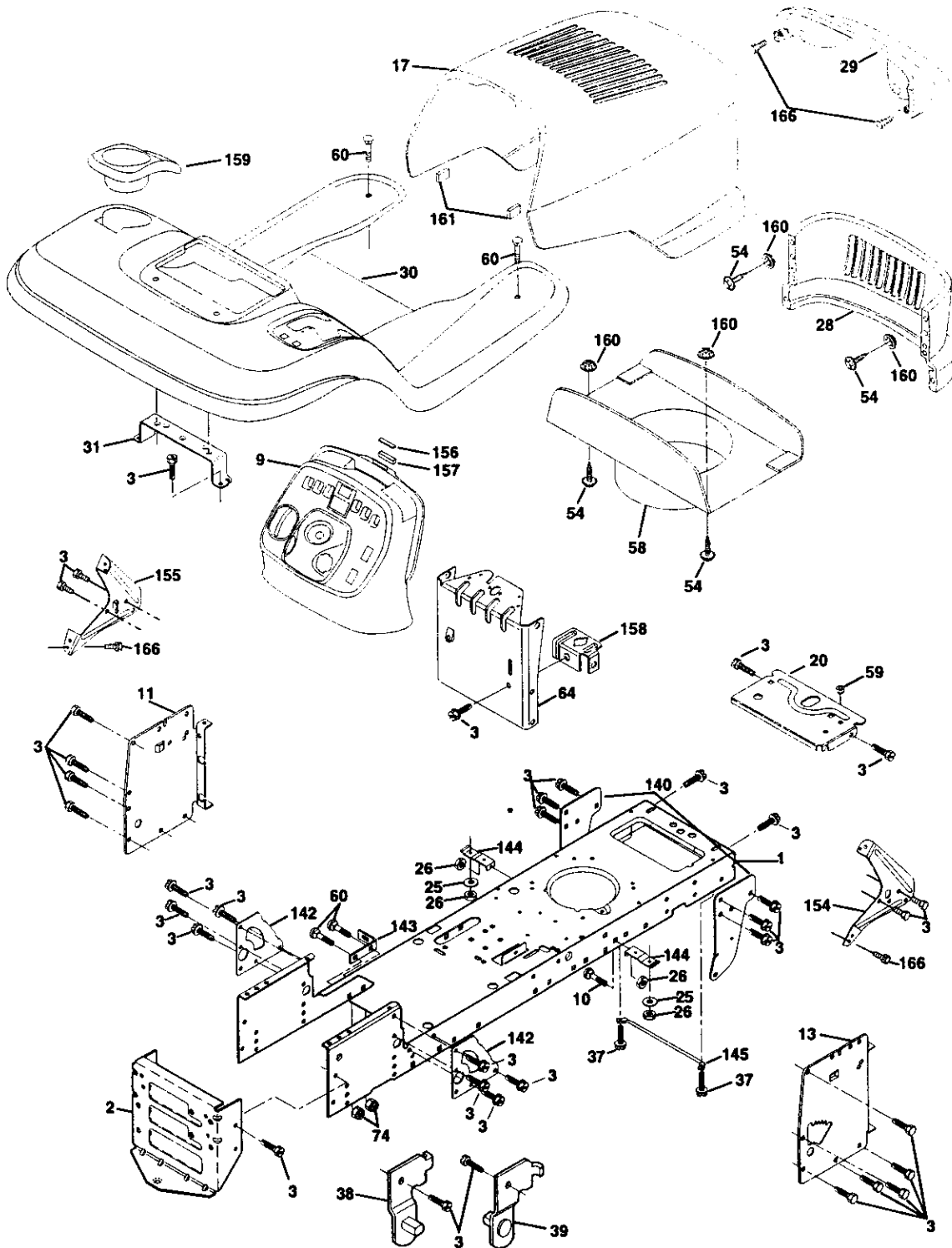

TRACTOR - - MODEL NUMBER 917.272140
CHASSIS AND ENCLOSURES

KEY	PART	
NO.	NO.	DESCRIPTION
1	166819	Chassis
2	140356	Drawbar
3	17490612	Screw, Thd., Roll. 3/8-16 x 3/4 Type TT
9	163976	Dash, Stealth YGTG 2 cyl
10	STD533710	Bolt, Carriage 3/8-16 x 1
11	163455	Panel, Dash, LH
13	163456	Panel, Dash, RH
17	161023X558	Hood Assembly
20	162026	Plate Battery Styt
25	19131312	Washer 13/32 x 13/16 x 12 Gauge
26	STD541437	Locknut, Hex, with Insert 3/8-16 UNC
28	160564X558	Grille, MS-558
29	161235	Lens, Grille
30	154791X558	Fender/Footrest
31	139976	Bracket, Fender/Support
37	17490508	Screw, Thdrol. 5/16-18 x 1/2 TYT
38	139886	Pivot Bracket Assembly, LH, Mower, Rear
39	139887	Pivot Bracket Assembly, RH, Mower, Rear
54	161464	Screw Hex Wshd 8-18 x 7/8
58	161236	Duct Hood Stealth
59	110436X	Bushing, Snap, Split
60	STD533707	Bolt Rdhd Sqnk 3/8-16 UNC x 3/4
64	162025	Dash Lower STYT
74	STD541437	Nut Crownlock 3/8-16 UNC
140	158418	Bracket Suspension Front
142	165867	Plate Reinforcement STLT
143	154966	Backrest Swaybar Chassis
144	154207	Bracket Footrest STLT
145	156524	Rod Pivot Chassis/Hood
154	161897	Bracket Dash Stealth Rh
155	161900	Bracket Dash Stealth Lh
156	163805	Striker Plate Stealth
157	163806	Magnet Stealth Ytgt
158	162037	Parking Brake Bkrt
159	155123X428	Cupholder Stil Blk
160	162967	Fastner Nutpal
161	164655	Extrusion Bumper
166	164863	Screw HwHd Hi-Lo #13-16 x 3/4

NOTE: All component dimensions given in U.S. inches
1 inch = 25.4 mm

TRACTOR -- MODEL NUMBER 917.272140

GROUND DRIVE

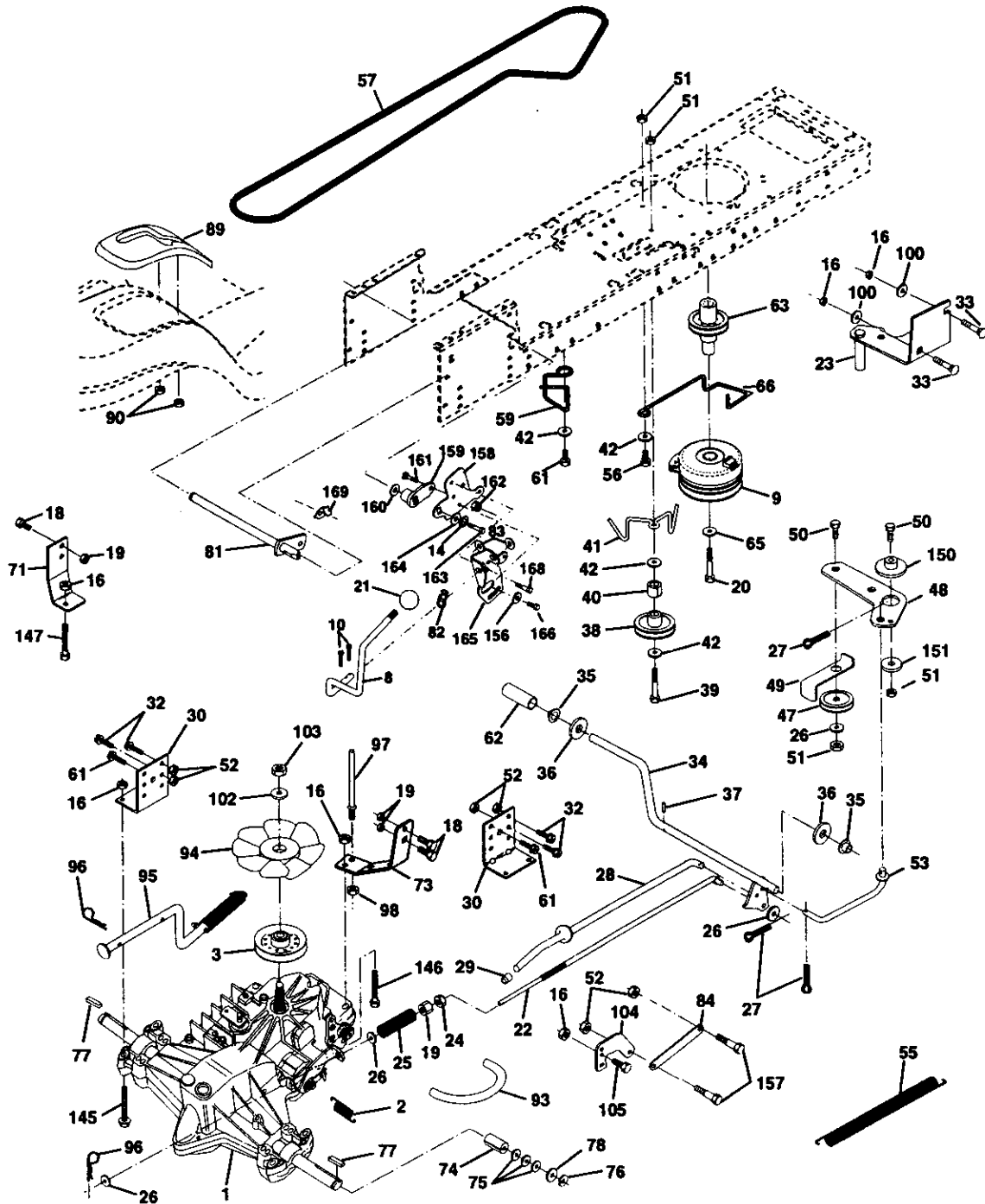

TRACTOR -- MODEL NUMBER 917.2/2140

GROUND DRIVE

KEY NO.	PART NO.	DESCRIPTION	KEY NO.	PART NO.	DESCRIPTION
1	-----	Transaxle (See Breakdown)	66	154778	Keeper Belt Engine Hydro
		Hydro Gear 319-0650	71	140158	Strap Torque Lh Hydro 18/20" T
2	142431	Spring, Return, Brake	73	156347	Strap Torque Rh Hydro 18/20" T
3	143995	Pulley, Transaxle	74	121199X	Spacer, Split
8	165866	Rod Shift Fender	75	121749X	Washer 25/32 x 1-1/4 x 16 Ga
9	160889	Clutch Elec Evx	76	12000001	E-Ring
10	76020416	Pin Cotter 1/8 x 1 CAD	77	123583X	Key, Square
14	10040400	Washer Lock Hvy Helical	78	121748X	Washer 25/32 x 1-5/8 x 16 Gauge
16	73800500	Nut Lock Hex W/Ins. 5/16-18 Unc	81	165591	Shaft Asm. Cross Tapered 650 20
18	74780616	Bolt Fin Hex 3/8-16 Unc x 1 Gr. 5	82	165711	Spring Torsion
19	73800600	Nut Lock Hex W/Wsh 3/8-16 Unc	83	19171216	Washer 17/32 x 3/4 x 16 Ga.
20	150280	Bolt Hex 7/16-20 x 4-1/4 5 Ga.	84	165815	Link Transaxle 0650 LT/YT/STL
21	130564	Knob, Deluxe 1/2-13	89	164890X428	Console, Shift
22	145627	Rod, Brake Hydro	90	124346X	Nut Self-Thd Wsh-hd 1/4 Zinc
23	154978	Bracket Asm Clutch Mtg Evx	93	142564	Line Fuel Hydro 4"
24	73350600	Nut, Hex Jam 3/8-16 Unc	94	140462	Fan, Hydro 7"
25	106888X	Spring, Brake Rod	95	144643	Control Bypass Hydro 20" Tires
26	19131316	Washer	96	4497H	Retainer Spring 1" Zinc/Cad
27	76020412	Pin Cotter 1/8 x 3/4 CAD.	97	140469	Keeper Bolt Rh Hydro 0750 18/20"
28	145204	Rod, Parking Brake	98	73510600	Nut Keps Hex 3/8-16 Unc
29	124236X	Cap, Parking Brake	100	19111216	Washer 11/32 x 3/4 x 16 Ga.
30	130807	Bracket, Transaxle	102	141322	Washer Belleville .501D x 1.50D
32	74760512	Bolt Hex Hd 5/16-18 Unc x 3/4	103	73940800	Nut Hex Jam Toplock 1/4-20 Unf
33	72140506	Bolt Rdhd Sqnk 5/16-18 Unc x 3/4	104	140156	Arm, Control Hydro
34	155071	Shaft, Foot Pedal	105	71070516	Screw Cap Hex 5/16 x 18 x 1
35	120183X	Bearing, Nylon	145	74490540	Bolt Hex Flghd 5/16-18 Gr. 5
36	19211616	Washer	146	74490536	Bolt Fin Hex 5/16-18 unc x 2-1/4
37	1572H	Pin, Roll	147	74490524	Bolt Fin Hex 5/16-18 unc x 1-1/2
38	131494	Pulley, Idler, Flat	150	165850	Bushing Bellcrank Grd Drive
39	74760644	Bolt	151	19133210	Washer 13/32 x 2 x 10 Ga.
40	4470J	Spacer, Split	156	166002	Washer Srted 5/16ID x 1 .125
41	165838	Keeper, Belt Idler	157	153236	Bolt, Shoulder 5/16-18 Unc-2A
42	19131312	Washer 13/32 x 13/16 x 12 Gauge	158	165589	Bracket Shift Mount
47	127783	Pulley, Idler, V-Groove	159	165494	Hub Tapered Flange Shift LT
48	154407	Bellcrank Clutch Gmd Drw Stl	160	19292016	Washer 29/32 x 1-1/4 x 16 Ga.
49	123205X	Retainer, Belt	161	72140406	Bolt Rdhd Sqnk 1/4-20 x 3/4 Gr 5
50	74760624	Bolt	162	73680400	Nut Crownlock 1/4-20 Unc
51	73680600	Nut Crownlock 3/8-16 UNC	163	74780416	Bolt Hex Fin 1/4-20 Unc x 1 Gr 5
52	73680500	Nut, Crownlock 5/16-18 Unc	164	19091010	Washer 5/8 x .281 x 10 Ga.
53	105710X	Link, Clutch	165	165623	Bracket Pivot Lever
55	105709X	Spring, Return, Clutch	166	166880	Screw 5/16-18 x 5/8
56	74760620	Bolt Hex 3/8-16 x 1-1/4	168	165492	Bolt Shoulder 5/16-18 x .561
57	140294	V-Belt, Ground Drive	169	165580	Plate Fastening
59	140312	Keeper, Center Span			
61	17490612	Screw Thdrol. 3/8-16 x 3/4 Ty. TT			
62	8883R	Cover, Pedal			
63	145868	Pulley, Engine			
65	10040700	Washer			

NOTE: All component dimensions given in U.S. inches
1 inch = 25.4 mm

TRACTOR -- MODEL NUMBER 917.272140
STEERING ASSEMBLY

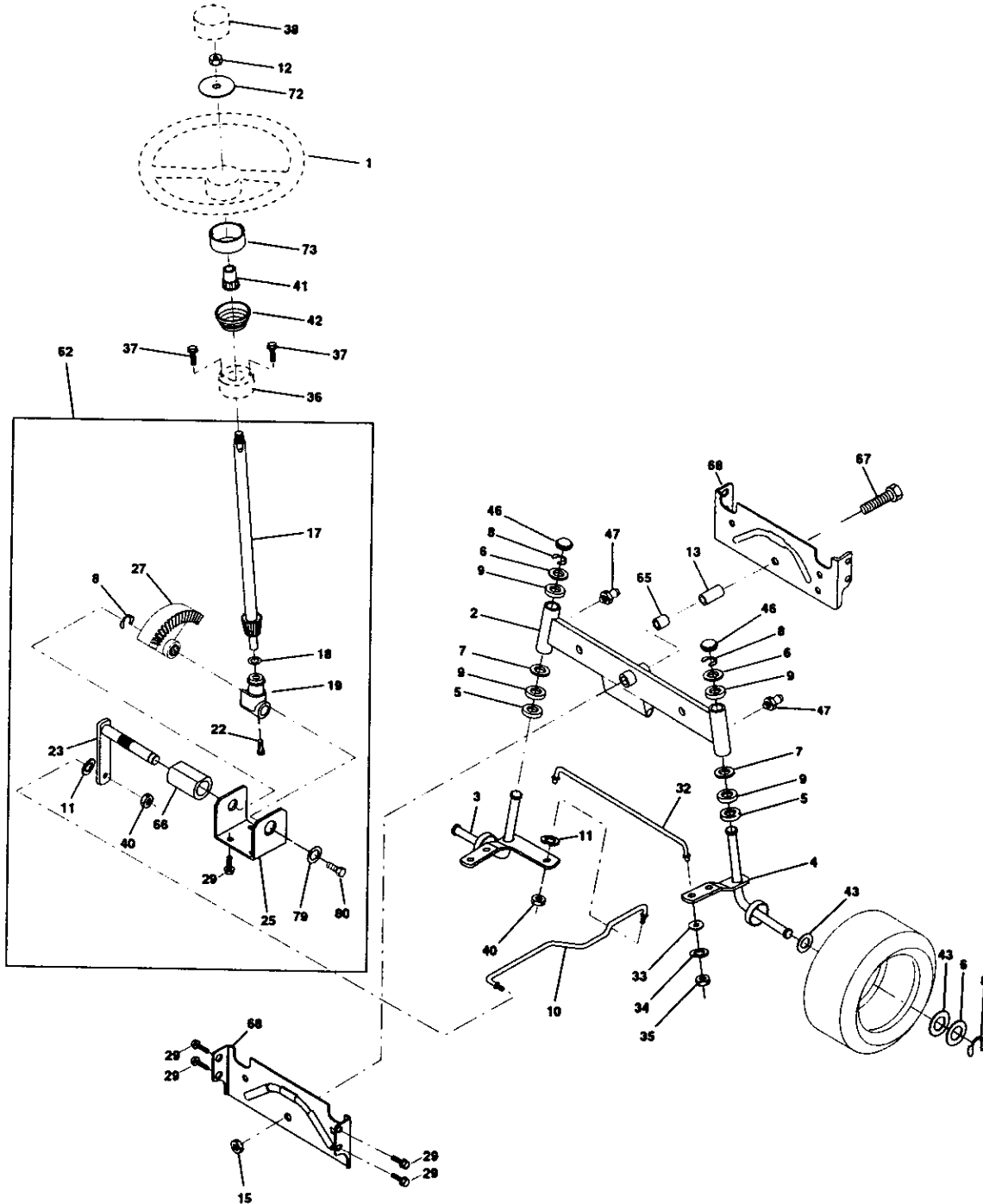

TRACTOR - - MODEL NUMBER 917.272140

STEERING ASSEMBLY

KEY NO.	PART NO.	DESCRIPTION
1	159944X428	Steering Wheel
2	154427	Axle Assembly STMP Dropped STL
3	156483	Spindle Assembly, L.H.
4	157473	Spindle Assembly, R.H.
5	6266H	Bearing, Race, Thrust, Hardened
6	121748X	Washer 25/32 x 1-5/8 x 16 Gauge
7	19272016	Washer 27/32 x 1-1/4 x 16 Gauge
8	12000029	Ring, Klip
9	3366R	Bearing, Steering Column
10	156438	Draglink Extended Stamped
11	STD551137	Washer, Lock
12	73940800	Nut Hex Jam Toplock 1/2-20 Unf
13	154779	Bearing Axle STLT/GT
15	73901000	Nut, Lock, Flange 5/8-11 UNC
17	156543	Shaft Assembly, Steering
18	57079	Washer, Thrust .515 x .750 x .033
19	160395	Support, Shaft
22	165857	Screw Hex Wshhd Torx
23	165851	Pittman Shaft Assembly
25	154406	Bracket, Steering
27	136874	Gear, Sector
29	17490612	Screw, Thd., Roll. 3/8-16 x 3/4
32	139929	Rod, Tie
33	19111216	Washer 11/32 x 3/4 x 16 Ga/
34	STD551131	Washer Lock Hvy Spr. 5/16
35	73810500	Locknut 5/16-24 Unf
36	155105	Bushing, Steering
37	152927	Screw
38	159946X428	Insert, Steering Wheel
40	STD541537	Gripco Nut
41	159945	Adaptor, Steering Wheel
42	163888	Boot, Steering Shaft
43	121749X	Washer 25/32 x 1-1/4 x 16 Gauge
46	121232X	Cap, Spindle
47	6855M	Fitting, Grease
62	167905	Kit Steering Asm Service
65	154780	Spacer Axle
66	154404	Bearing Arm Pittman
67	74781044	Bolt, Fin Hex 5/8-11 UNC x 2-3/4
68	154429	Axle, Brace
72	19182411	Washer 9/16 Id x 1-1/2Od 11 G Zin
73	160135	Steering Sleeve Extension
79	19132012	Washer 13/32 x 1-1/4 x 12 Ga.
80	74950612	Bolt Hex Nylon 3/8-16 x 3/4

NOTE: All component dimensions given in U.S. inches
1 inch = 25.4 mm

TRACTOR - - MODEL NUMBER 917.272140

ENGINE

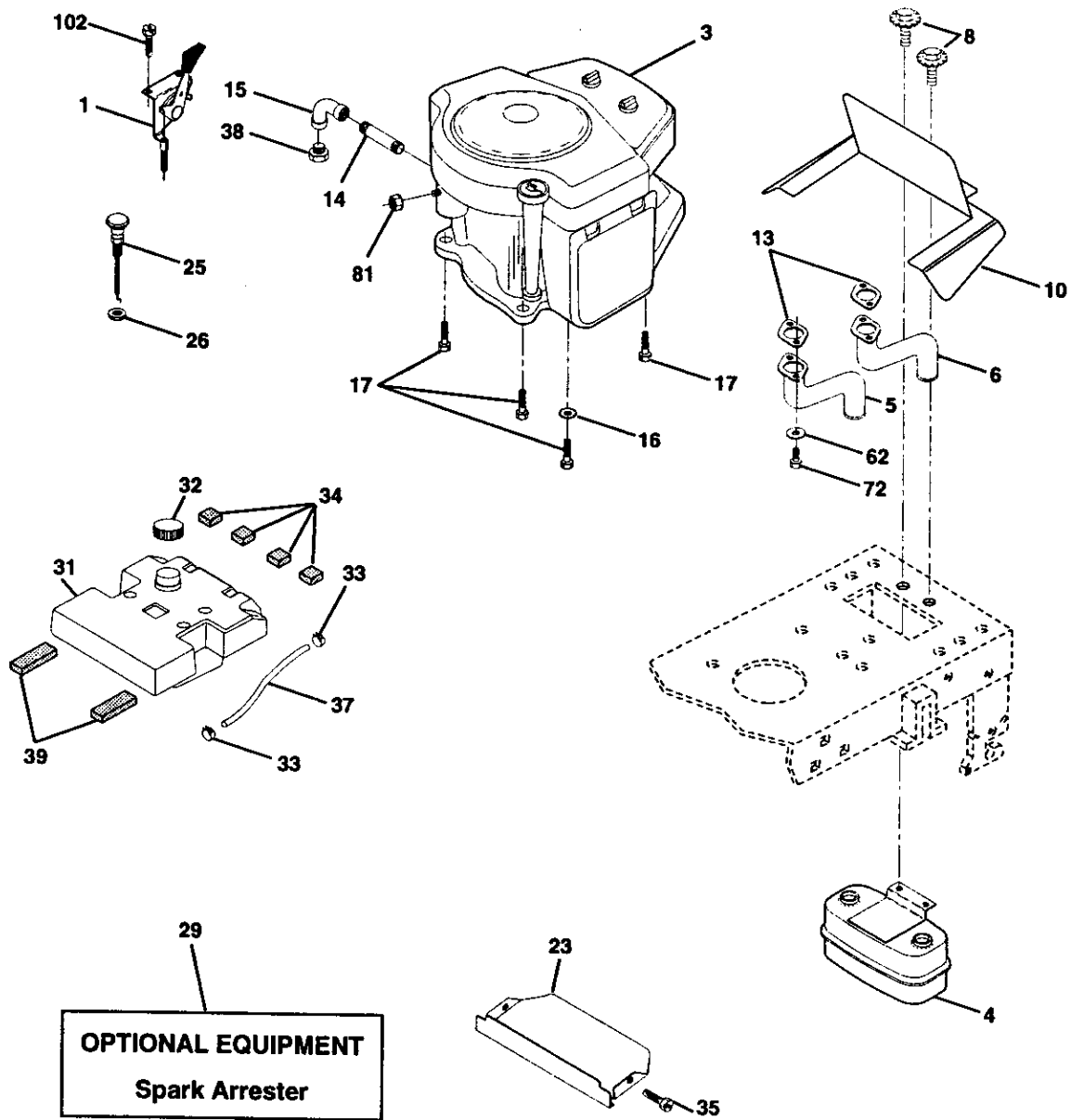

TRACTOR - - MODEL NUMBER 917.272140

ENGINE

KEY NO.	PART NO.	DESCRIPTION
1	164067	Control, Throttle
3	-----	Engine, (See Breakdown) Briggs Model 407777-0121-E1
4	149723	Muffler, Asm Twin Lo-Tone
5	159955	Exhaust Tube Lh
6	160589	Exhaust Tube Rh
8	150176	Bolt 5/16-18 Unc x 3/4 w/Sems
10	162797	Shield Browning B&S Intek II
13	165391	Gasket Muffler
14	13280336	Nipple, Pipe
15	13200300	Elbow, Standard 90°, 3/8-18 NPT
16	STD551237	Washer, Lock
17	17490624	Screw Thdrol 3/8-16 x 1-1/2 TT
23	159880	Shield Brv/Dbr Guard
25	164068	Control Choke
26	73920600	Nut Keps 3/8-24 Unf
29	137180	Arrestor, Spark
31	157103	Tank, Fuel
32	161696	Cap, Fuel Guage
33	123487X	Clamp, Hose
34	106082X	Pad Spacer
35	17490512	Screw Thdrol 5/16-18 x 3-4 Tyl
37	8543R	Line, Fuel
38	-----	Plug, Oil Drain (Order From Engine Manufacturer)
39	109227X	Pad Idler
62	10040500	Washer Lock Hvy Hlcl Spr 5/16
72	71070512	Screw Hex Hd Cap 5/16-18 x 3/4
81	128861	Nut Flange 1/4-20 Starter Nut
101	M73030800	Nut, Flange M801.25
102	164863	Screw Hwhd Hi-Lo #13-16 x 3/4

NOTE: All component dimensions given in U.S. inches
1 inch = 25.4 mm

TRACTOR -- MODEL NUMBER 917.272140

SEAT ASSEMBLY

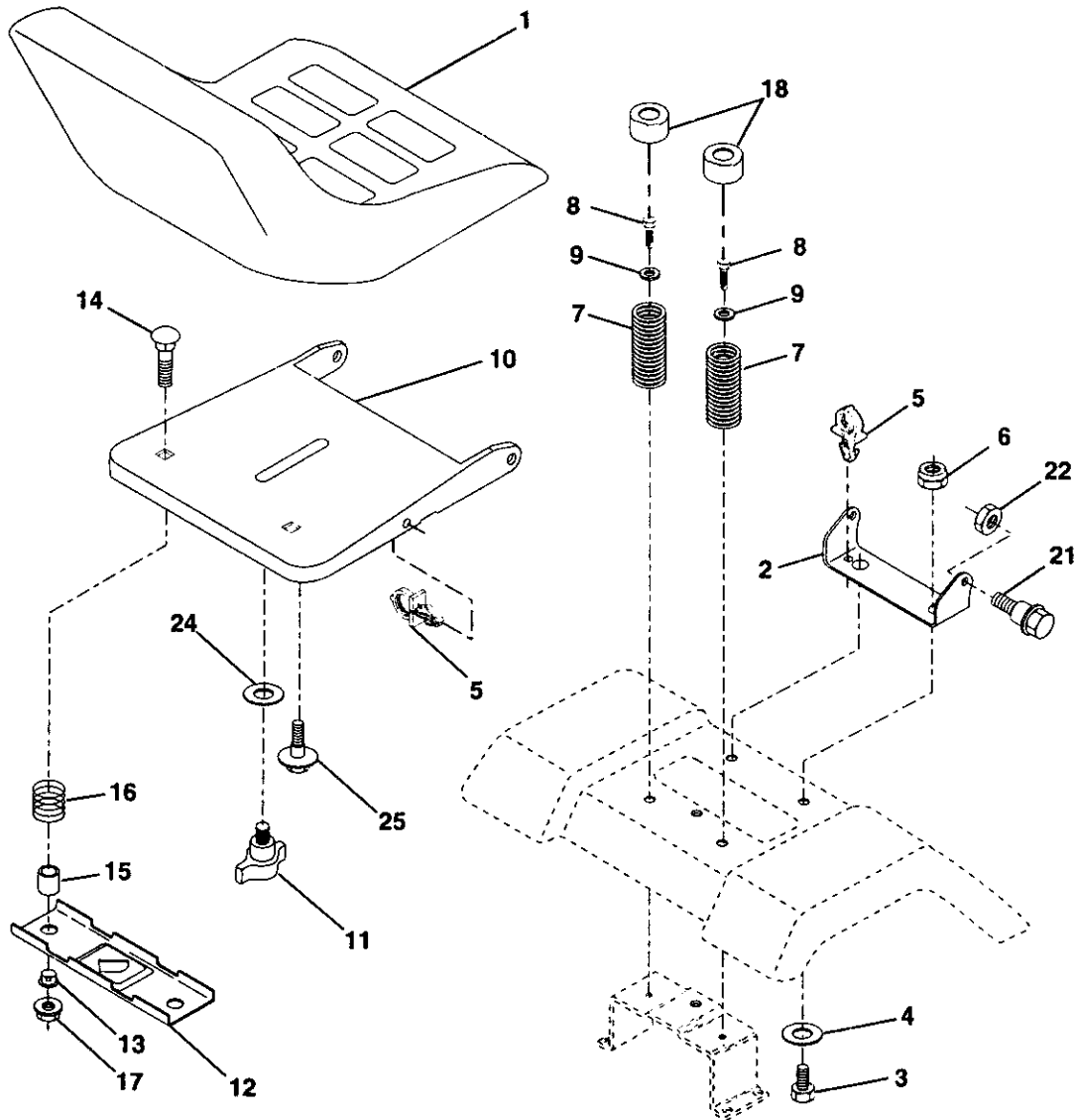

KEY NO.	PART NO.	DESCRIPTION
1	140124	Seat
2	140551	Bracket, Pivot, Seat
3	STD523710	Bolt
4	19131610	Washer 13/32 x 1 x 10 Gauge
5	145006	Clip, Push-In Hinged
6	STD541437	Nut
7	124181X	Spring, Seat
8	17490616	Screw, Thd., Roll. 3/8-16 x 1
9	19131614	Washer 13/32 x 1 x 14 Gauge
10	155925	Pan, Seat Emboss QCK Conn.
11	166369	Knob Seat
12	121246X	Bracket, Switch Mounting

KEY NO.	PART NO.	DESCRIPTION
13	121248X	Bushing, Snap
14	72050412	Bolt, Carriage 1/4-20 x 1-1/2
15	121249X	Spacer, Split .28 x .88
16	123740X	Spring
17	123976X	Locknut, Flange 1/4 Grade 5
18	124238X	Cap Spring Seat
21	153236	Bolt, Shoulder 5/16-18 UNC
22	STD541431	Nut
24	19171912	Washer 17/32 x 1-3/16 x 12 Gauge
25	127018X	Bolt, Shoulder 5/16-18 x .62

NOTE: All component dimensions given in U.S. inches
1 inch = 25.4 mm

TRACTOR - - MODEL NUMBER 917.272140

DECALS

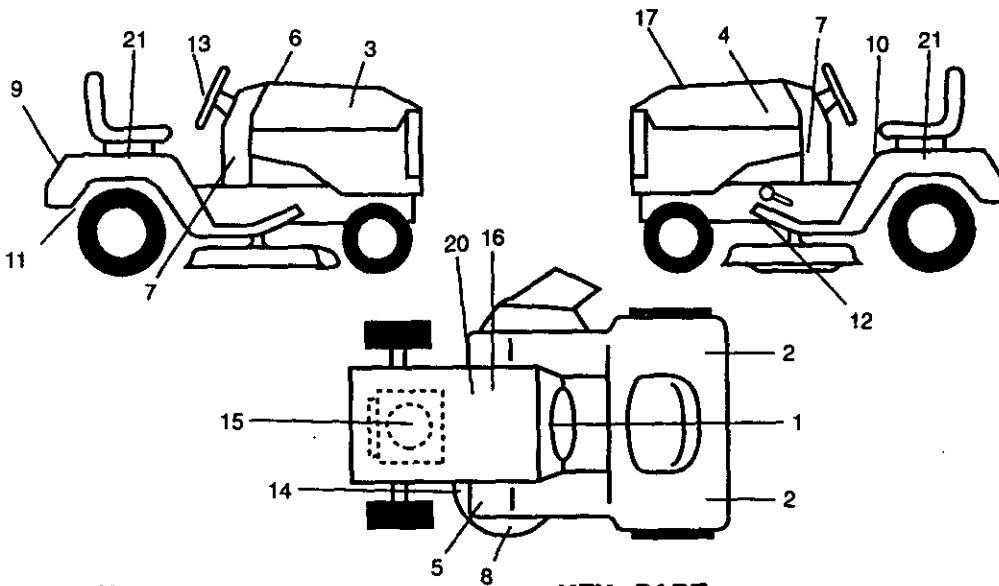

KEY NO.	PART NO.	DESCRIPTION	KEY NO.	PART NO.	DESCRIPTION
1	164094	Decal, Dash, Stealth	13	164065	Decal Strg Wheel
2	106202X	Reflector Tail Light	14	160397	Decal, V-Belt Schematic
3	163916	Decal, Hood, R.H.	15	165399	Decal, HP Engine
4	163917	Decal, Hood, L.H.	16	138047	Decal, Battery Diehard
5	164088	Decal Brake Clutch Stealth	17	167185	Decal, Replacement Srs
6	133644	Decal, Customer Maintenance	20	149516	Decal, Battery Dngr/Psn Eng
7	167330	Decal Dash Pnl Kohler	21	163206	Decal, Fender Side
8	166887	Decal, Deck EZ	--	138311	Decal, Lift Handle
9	163204	Decal, Fender, Craftsman	--	154515	Pad Footrest LH STLT
10	156439	Decal, Fender Danger	--	154516	Pad Footrest RH STLT
11	142341	Decal, Drawbar Cntrl Mvt Hyd Lt	--	168150	Owner's Manual, English
12	146046	Decal, V-Belt Drive Schematic	--	168151	Owner's Manual, Spanish

WHEELS & TIRES

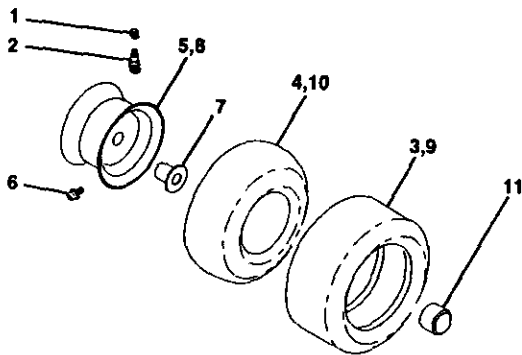

KEY NO.	PART NO.	DESCRIPTION
1	59192	Valve Cap, Tire
2	65139	Stem, Valve
3	106222X	Tire, Front
4	59904	Tube, Front Tire (Not Provided, Service Item Only)
5	106732X427	Rim, Front
6	278H	Fitting, Grease (Front Wheel Only)
7	9040H	Bearing, Flange (Front Wheel Only)
8	106108X427	Rim, Rear
9	122082X	Tire, Rear
10	7152J	Tube, Rear Tire (Not Provided, Service Item Only)
11	104757X	Cap, Axle
--	144334	Sealant, Tire 10 oz.

NOTE: All component dimensions given in U.S. inches
1 inch = 25.4 mm

TRACTOR -- MODEL NUMBER 917.272140

LIFT ASSEMBLY

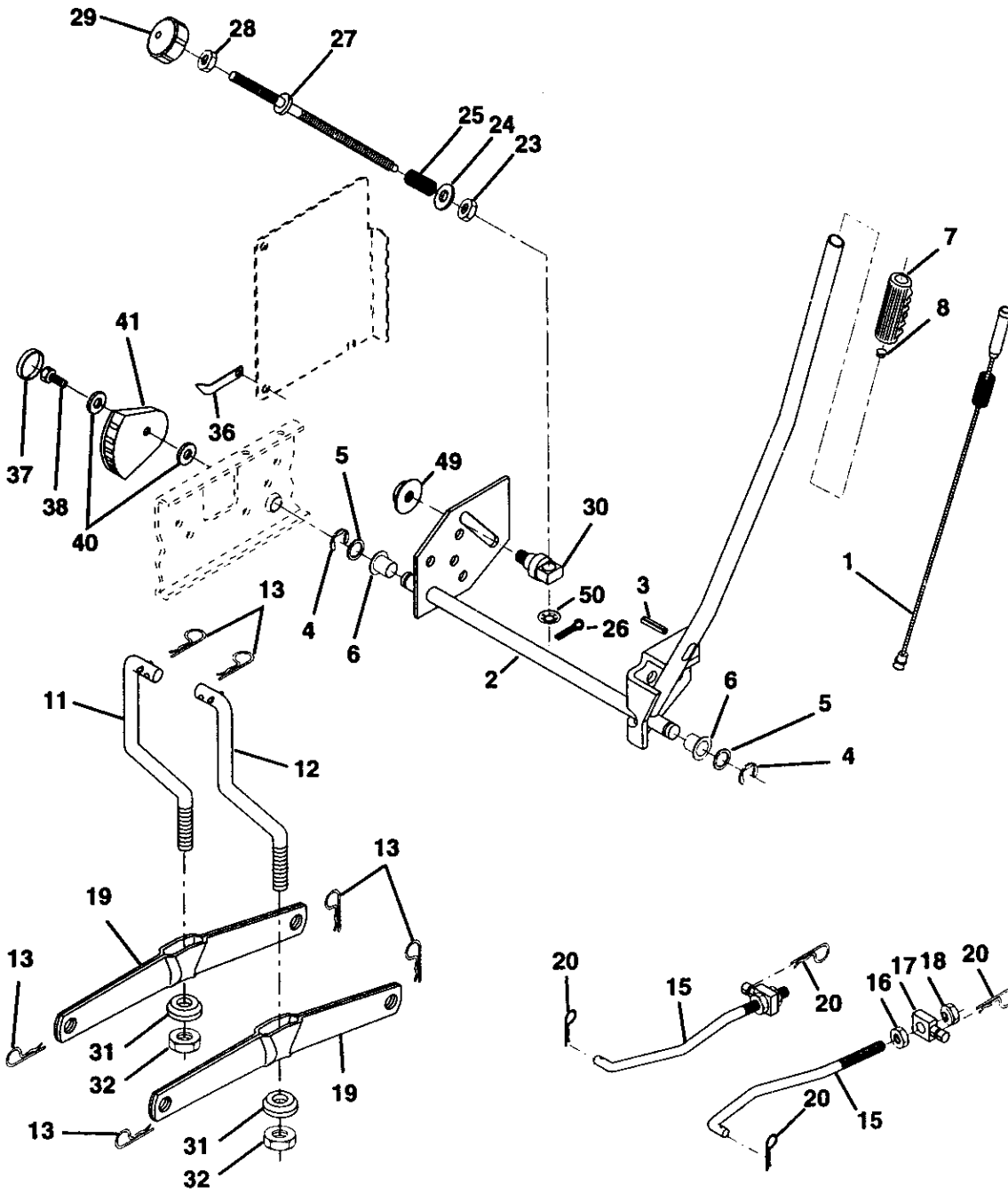

TRACTOR - - MODEL NUMBER 917.272140

LIFT ASSEMBLY

KEY NO.	PART NO.	DESCRIPTION
1	159461	Lift Lever Inner Wire Assembly
2	159476	Shaft Assembly, Lift
3	138284	Pin, Groove
4	12000002	E-Ring
5	19211621	Washer 21/32 x 1 x 21 Gauge
6	120183X	Bearing, Nylon
7	125631X	Grip, Handle, Fluted
8	122365X	Button, Plunger, Red
11	139865	Link, Lift, L.H.
12	139866	Link, Lift, R.H.
13	4939M	Retainer Spring
15	127218	Link, Front
16	73350800	Nut, Hex, Jam 1/2-13 UNC
17	130171	Trunnion
18	73680800	Nut Crownlock 1/2-13 Unc
19	139868	Arm, Suspension, Rear
20	163552	Retainer Spring
23	110807X	Nut Special
24	19131016	Washer 13/32 x 5/8 x 16 Ga.
25	164024	Spring Comp Infinite
26	76020308	Pin Cotter 3/32-1/2
27	164543	Rod Adj Lift Zinc
28	73350600	Nut Hex Jam 3/8-16 unc
29	138057	Knob Infin 3/8-16 unc Blk Sym
30	150233	Trunnion Infin Height
31	140302	Bearing, Pvt, Lift Spherical
32	73540600	Nut, Crownlock 3/8-24
36	155097	Pointer Height Indicator
37	123935X	Plug Hole
38	17490512	Screw Thdrol 5/16-18 x 3/4
40	19112410	Washer 11/32 x 1-1/2 x 10 Ga
41	155098	Indicator Height Slit
49	145212	Nut Hex/Large Lock
50	110452X	Nut Push Phos & Oil

NOTE: All component dimensions given in U.S. inches
1 inch = 25.4 mm

TRACTOR - - MODEL NUMBER 917.272140

MOWER DECK

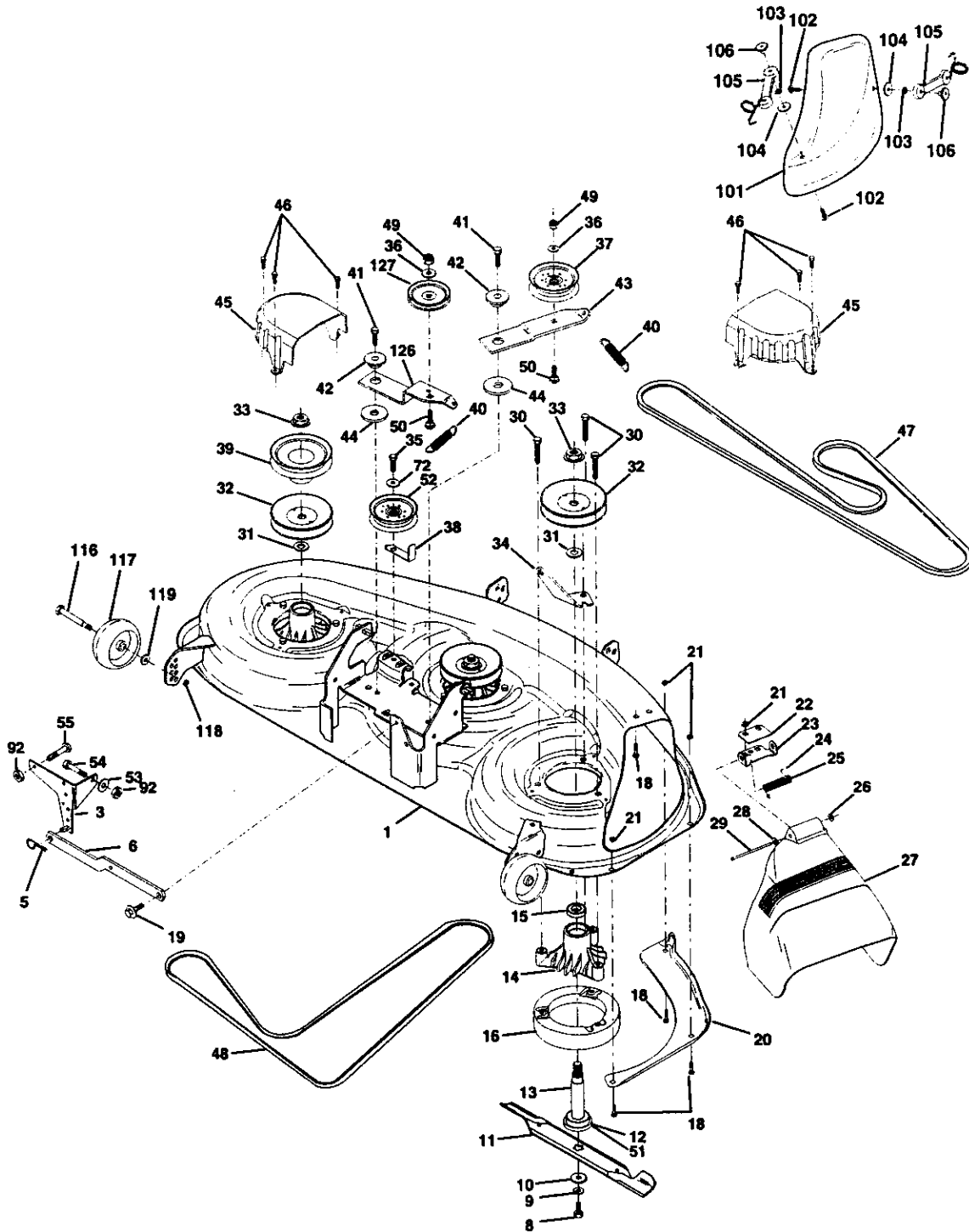

TRACTOR - - MODEL NUMBER 917.272140

MOWER DECK

KEY NO.	PART NO.	DESCRIPTION	KEY NO.	PART NO.	DESCRIPTION
1	164210	Deck Weldment. 46"	40	137273	Spring, Secondary 44/46/50
3	138457	Bracket Asm., Sway Bar			Vent
5	STD624008	Retainer Spring	41	17490620	Screw, Thdroll 3/8-16 x 1-1/4
6	130832	Arm, Suspension, Rear (Sway Bar)			Tytl
8	850857	Bolt, Patched 3/8-24 x 1-1/4 Gr. 8	42	122052X	Spacer, Retainer
9	STD551137	Washer, Lock Hvy., Unplated 3/8	43	144949	Arm, Idler Secondary
10	140296	Washer, Hard Blade, Mower Vented	44	133943	Washer, Hardened
11	163819	Blade, 3-IN-1, 46"	45	145059	Cover, Mandrel Deck
12	129895	Bearing, Ball, Mandrel #6204	46	137729	Screw, Thdroll. 1/4-20 x 5/8
13	137553	Shaft Asm. w/Lower Bearing (Includes Key No. 12)	47	144959	V-Belt, Mower, Secondary
14	137152	Housing, Mandrel	48	148763	V-Belt, Mower, Primary
15	110485X	Bearing, Ball, Mandrel	49	STD541437	Nut, Crownlock 3/8-16 UNC
16	140329	Stripper, Mower Round	50	72110612	Bolt, Carriage 3/8-16 x 1-1/2 Gr. 5
18	STD533106	Bolt, Carriage 5/16-18 x 5/8	51	153390	Washer Felt
19	132827	Bolt, Hex Head, Shoulder 5/16-18	52	156493	Pulley Idler 46" Prim. Drive
20	145055	Baffle, Vortex Mower 46"	53	19131312	Washer 13/32 x 13/16 x 12 Ga
21	STD541431	Nut, Crownlock 5/16-18 UNC	54	74780616	Bolt Fin Hex 3/8-16 Unc x 1 Gr. 5
22	134753	Stiffener, Bracket	55	72140608	Bolt Rdhd Sqnk 3/8-16 Unc x 1
23	131267	Bracket, Deflector	72	19131616	Washer 13/32 x 1 x 16 Ga
24	105304X	Cap, Sleeve	92	STD541437	Nut Lock Hex w/Ins 3/8-16 Unc
25	149287	Spring, Torsion, Deflector	101	145579	Cover, Mulching
26	110452X	Nut, Push	102	71161010	Screw
27	157788	Shield, Deflector Mower	103	STD551110	Washer, Lock #10
28	19111016	Washer 11/32 x 5/8 x 16 Ga.	104	19061216	Washer
29	131491	Rod, Hinge	105	160793	Latch Asm. Bagger
30	157722	Screw, Thd Rolling Washer Head	106	2029J	Nut, Weld
31	129963	Washer, Spacer Mower Vented	116	137644	Bolt, Shoulder
32	153531	Pulley, Mandrel	117	133957	Gauge Wheel
33	137266	Nut, Fig. Top Lock Cntr. 9/16	118	73930600	Nut, Centerlock 3/8-16 UNC
34	144945	Anchor, Spring Deck 46"	119	19121414	Washer 3/8 x 7/8 x 14 Ga.
35	17490628	Screw, Thdroll 3/8-16 x 1-3/4 Tytl	126	144948	Arm, Idler, Primary Deck 46"
36	STD551037	Washer 13/32 x 13/16 x 16 Ga.	127	146763	Pulley, Idler, V-Groove Dim. 4.25
37	131494	Pulley, Idler, Flat	--	166222	Mower Service 46" (Standard Deck - Order separately mulching and guage wheel components Key Nos. 101-106 and 116-119
38	156086	Keeper, Belt, Idler	--	143651	Mandrel Asm 44/50 Service (Includes Key Nos. 8-10, 12-15, 31 and 33)
39	144917	Pulley, Idler, Driven			

NOTE: All component dimensions given in U.S. inches
1 inch = 25.4 mm

TRACTOR - - MODEL NUMBER 917.272140
HYDRO GEAR TRANSAXLE - - MODEL NUMBER 319-0650

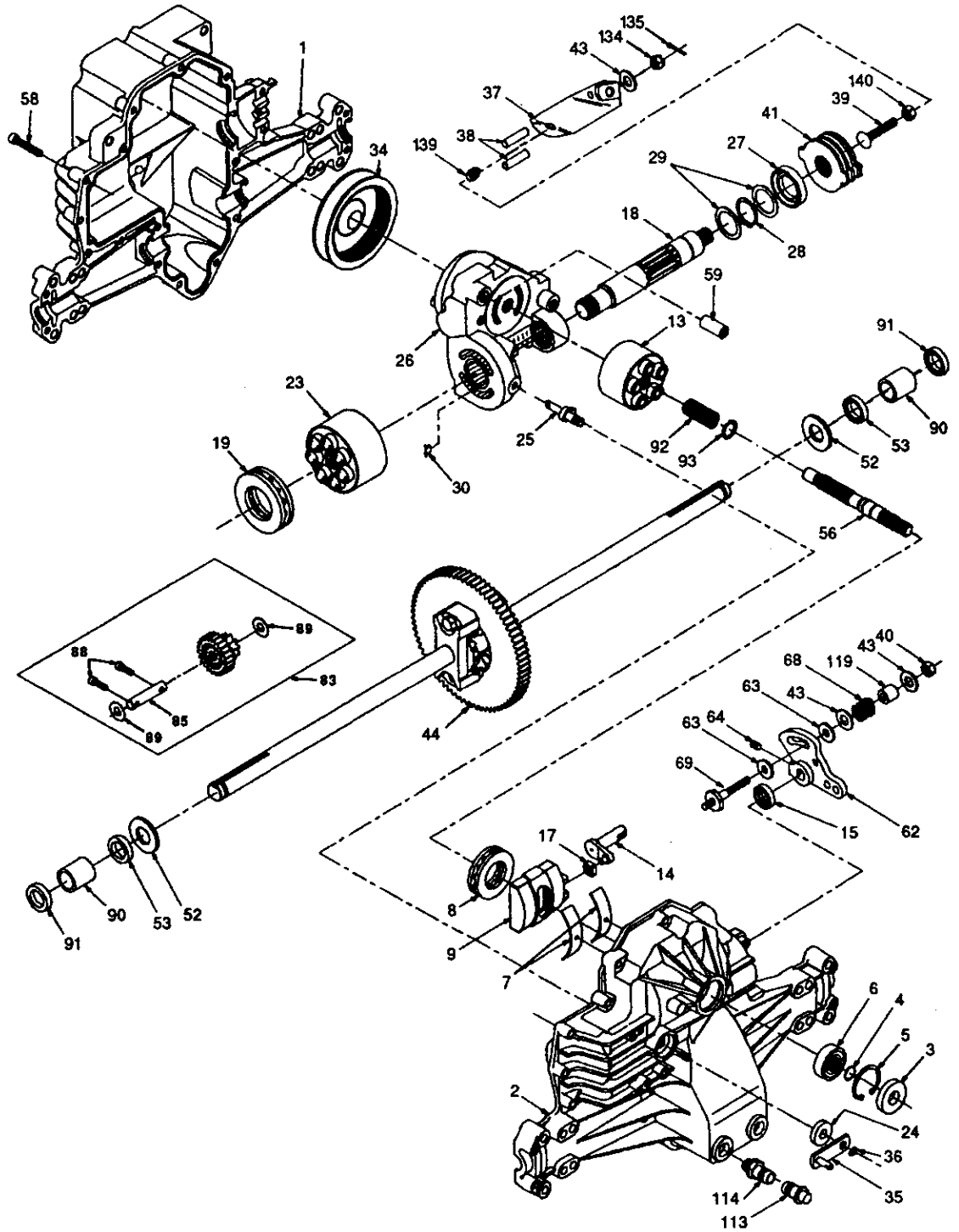

TRACTOR - - MODEL NUMBER 917.272140

HYDRO GEAR TRANSAXLE - - MODEL NUMBER 319-0650

KEY NO.	PART NO.	DESCRIPTION	KEY NO.	PART NO.	DESCRIPTION
1	142930	Housing, Lower	43	142884	Washer 7/16 x 7/8 x .060
2	142931	Assembly, Upper Housing	44	150829	Differential Assembly
3	142932	Seal, Lip	52	142991	Washer 3/4 x 1.5 x .13
4	142928	Ring, Wire Retaining	53	142961	Seal .75 x 1.25 x .250
5	142933	Ring, Retaining	56	142963	Shaft, Input
6	142934	Bearing, Shaft Ball	58	142964	Bolt 1/4-20 x 1.38
7	142935	Bearing, Cradle	59	142965	Pin .5 OD x .43 ID x .750
8	150771	Bearing, Thrust 30 x 52 x 13	62	142966	Arm, Control
9	142937	Swashplate, Variable	63	142967	Puck, Dampener
13	142938	Block, Cylinder Assembly	64	142920	Set Screw
14	142939	Arm, Trunnion	68	142969	Spring
15	142940	Seal, Lip	69	144610	Stud 5/16-24
17	142941	Guide, Slot	83	142971	Jackshaft Assembly
18	150772	Shaft, Motor	85	150806	Jackshaft
19	150773	Bearing, Thrust 42 x 68 x 16	88	142973	Screw, Cap
23	142944	Block, Cylinder Assembly	89	142974	Washer 7/16 x 1 x 1/2
24	142945	Seal, Lip 10 x 25 x 7	90	142975	Sleeve Bearing
25	142946	Actuator, Bypass	91	142976	Seal, Wiper
26	150774	Center Section Assembly Kit	92	142977	Spring, Block
27	142948	Seal, Lip 26 x 42 x 8	93	142978	Washer, Block Thrust
28	142949	Ring, Retaining	113	142917	Cap, Vent Assembly
29	142950	Washer 26 x 35 x 1	114	142918	Fitting, O-Ring Assembly
30	150787	Plate, Bypass	119	142980	Spacer
34	142951	Oil Filter Element	134	144607	Nut, Castle 5/16-24
35	142952	Arm, Bypass	135	144608	Pin, Cotter
36	142953	Ring, Retaining	139	150775	Spring, Compression
37	142954	Arm, Actuating	140	150776	Nut, Hex 5/16-24
38	142955	Pin, Actuating			
39	150777	Bolt 5/16-24 x 1-3/4			
40	150778	Locknut, Hex 5/16-24 UNJC			
41	142958	Brake Rotor/Stator Kit			

NOTE: All component dimensions given in U.S. inches 1 inch = 25.4 mm

TRACTOR - - MODEL NUMBER 917.272140
BRIGGS ENGINE-MODEL NUMBER 407777,TYPE NUMBER 0121-E1

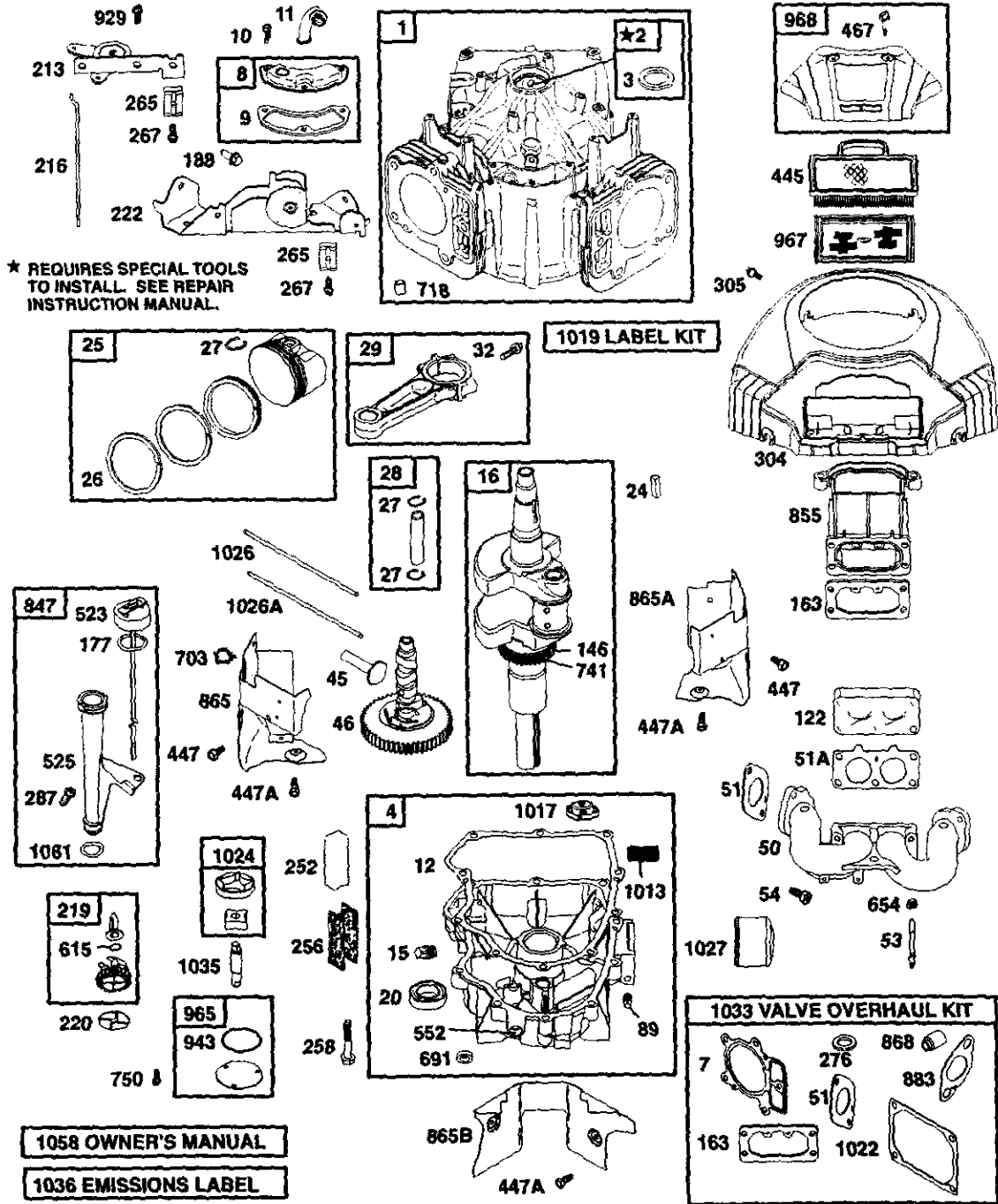

TRACTOR - - MODEL NUMBER 917.272140
BRIGGS ENGINE-MODEL NUMBER 407777,TYPE NUMBER 0121-E1

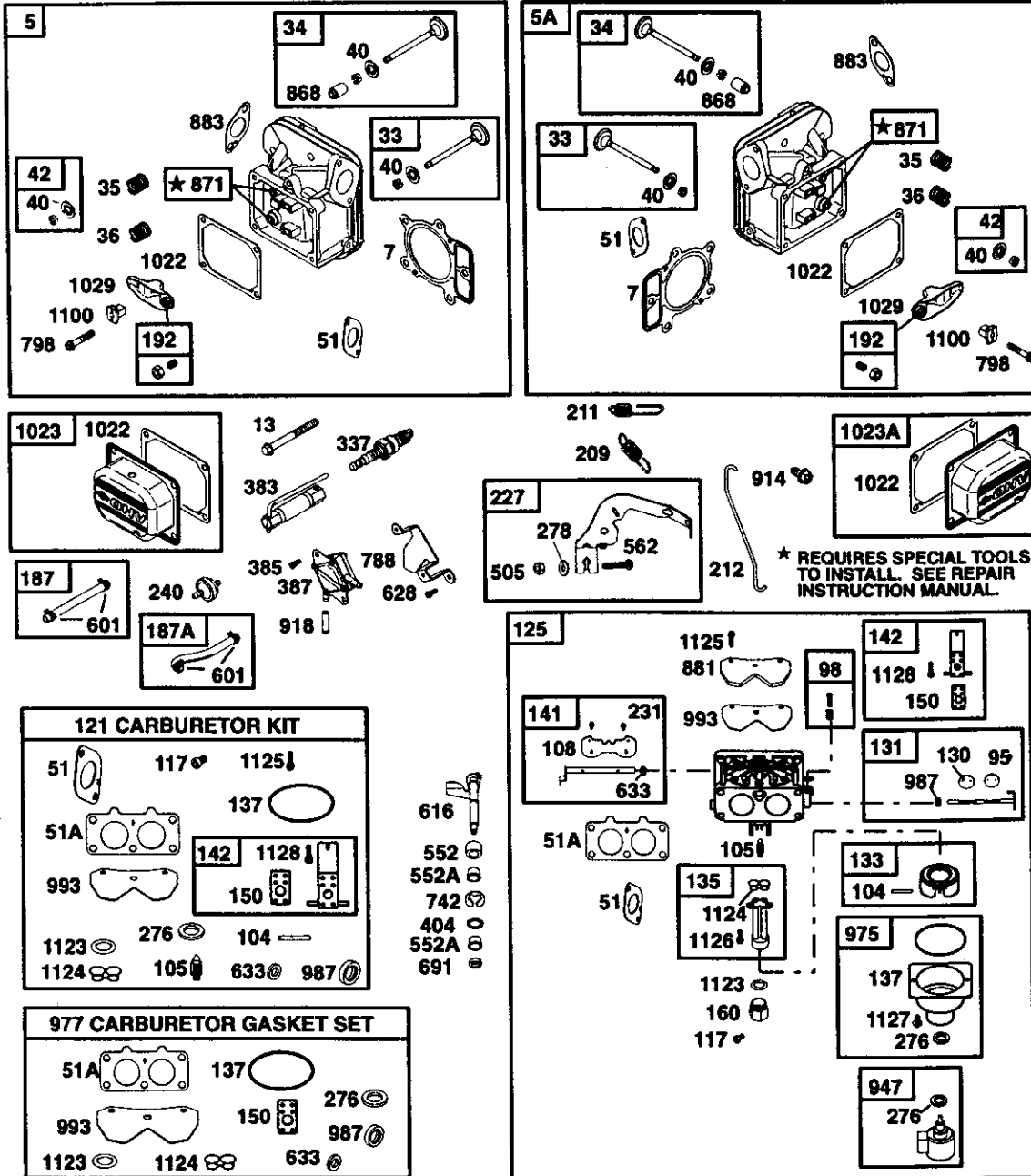

TRACTOR - - MODEL NUMBER 917.272140
BRIGGS ENGINE-MODEL NUMBER 407777,TYPE NUMBER 0121-E1

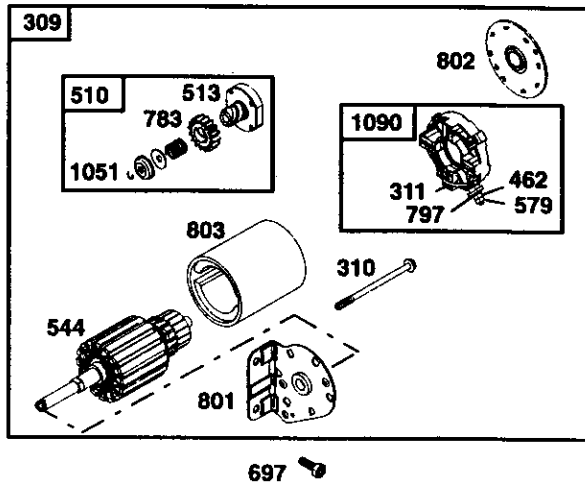
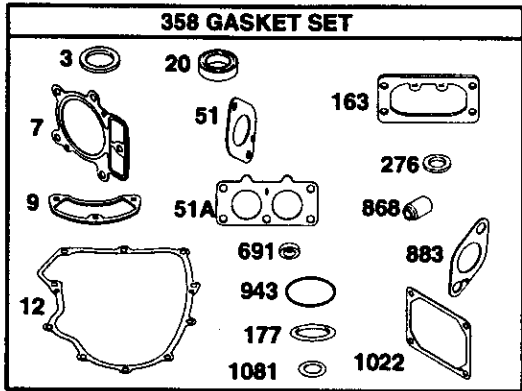
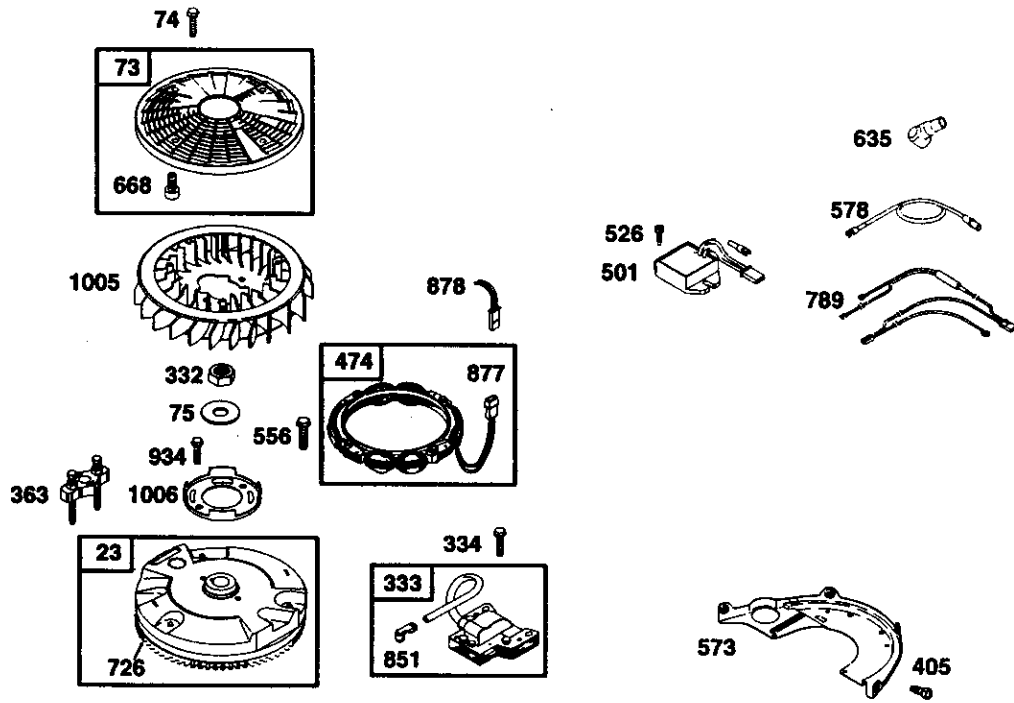

TRACTOR - - MODEL NUMBER 917.272140

BRIGGS ENGINE-MODEL NUMBER 407777,TYPE NUMBER 0121-E1

KEY NO.	PART NO.	DESCRIPTION	KEY NO.	PART NO.	DESCRIPTION
1	690231	Cylinder Assembly	131	499805	Throttle Shaft Kit
2	499585	Bushing-Cylinder	133	499806	Float-Carburetor
3	690926	+ Seal-Oil	135	499803	Fuel Transfer Tube
4	690069	Sump-Engine	137	690994	◆ Gasket-Float Bowl
5	499587	Head-Cylinder No. 1	141	499807	Choke Shaft Kit
5A	499595	Head-Cylinder No. 2	142	499808	● Nozzle-Carburetor
7	690962	+* Gasket-Cylinder Head	146	94388	Key-Timing
8	499601	Breather Assembly	150	281767	◆ Gasket-Nozzle
9	690937	+ Gasket-Breather	160	690996	Retainer-Solenoid
10	690960	Screw (Breather Assy.)	163	691001	+* Gasket-Air Cleaner
11	690942	Tube-Breather	177	691031	+ O-Ring Seal (Dipstick)
12	690945	+ Gasket-Crankcase	187	691050	Line-Fuel (Cut to Required Length)
13	690360	Screw (Cylinder Head)	187A	691049	Line-Fuel
15	690946	Plug-Oil Drain	188	690960	Screw (Control Bracket)
16	691046	Crankshaft	192	690083	Adjuster-Rocker Arm
20	690947	+ Seal-Oil (PTO Side)	209	690018	Spring-Governor
23	691053	Flywheel	211	690019	Spring-Governed Idle
24	690974	Key-Flywheel	212	691020	Link-Throttle
25	499588	Piston Assembly (Std.)	213	691021	Bracket-Choke Control
	499589	Piston Assembly (.010 "O.S.)	216	691022	Link-Choke
	499590	Piston Assembly (.020" O.S.)	219	394348	Gear-Governor
	499591	Piston Assembly (.030" O.S.)	220	690412	Washer (Governor Lever)
26	499604	Ring Set-Piston (Std.)	222	691023	Bracket-Control
	499605	Ring Set-Piston (.010 "O.S.)	227	691048	Control Lever-Governor
	499606	Ring Set-Piston (.020 "O.S.)	231	690718	Screw (Choke Valve)
	499607	Ring Set-Piston (.030 "O.S.)	240	691035	Filter-Fuel
27	690975	Lock-Piston Pin	252	690956	Element-Breather
28	499582	Pin-Piston	256	690957	Retainer-Element
29	499583	Rod-Connecting	258	690308	Screw (Engine Sump)
32	690976	Screw (Connecting Rod)	265	691024	Clamp-Casing
33	499596	Valve-Exhaust	267	691044	Screw (Casing Clamp)
34	499597	Valve-Intake	276	690997	+◆ Sealing Washer
35	690963	Spring-Valve (Intake)	278	690097	Washer (Gov. Control Lever)
36	690963	Spring-Valve (Exhaust)	287	690960	Screw (Dipstick Tube)
40	690964	Retainer-Valve	304	691004	Housing-Blower
42	499586	Keeper-Valve	305	691005	Screw (Blower Housing)
45	690977	Valve Tappet	309	691262	Motor-Starter
46	690978	Cam Shaft	310	691263	Bolt-Starter Motor
48	692714	ShortBlock	311	691264	Brush Set
50	690948	Manifold-Intake	332	690059	Nut (Flywheel)
51	690949	+◆ Gasket-Intake	333	691060	Armature-Magneto
51A	690950	+◆ Gasket-Intake	334	691061	Screw (Armature)
53	690951	Stud (Carburetor)	337	691043	Spark Plug
54	690953	Screw (Intake Manifold)	358	499889	Gasket Set
73	691055	Screen-Rotating	363	691062	Flywheel Puller
74	691057	Screw (Rotating Screen)	383	690966	Wrench-Spark Plug
75	691056	Washer (Flywheel)	385	690960	Screw (Fuel Pump)
89	690238	Plug-Oil	387	691034	Pump-Fuel
95	690718	Screw (Throttle Valve)			
98	499802	Idle Speed Kit			
104	690984	Pin-Float Hinge	+		Included in Gasket Set, Ref. No. 358
105	690985	Valve-Float Needle			Included in Gasket Set, Ref. No. 121
108	690986	Valve-Choke	u		Included in Gasket Set, Ref. No. 977
117	690232	Jet-Main (Standard)	U		Included in Gasket Set, Ref. No. 1033
117	690989	Jet-Main High Altitude)			
121	499811	Carburetor Overhaul Kit			
122	690952	Spacer-Carburetor			
125	499804	Carburetor			
130	690993	Valve-Throttle			

NOTE: All component dimensions given in U.S. inches
1 inch = 25.4 mm

TRACTOR - - MODEL NUMBER 917.272140
BRIGGS ENGINE-MODEL NUMBER 407777,TYPE NUMBER 0121-E1

KEY NO.	PART NO.	DESCRIPTION	KEY NO.	PART NO.	DESCRIPTION
404	690442	Washer (Governor Crank)	868	690968	+* Seal-Valve
405	690960	Screw (Back Plate)	871	690969	Bushing-Guide
445	691007	Filter-Air Cleaner Cartridge	877	399916	Alternator Connector/Wire
447	691003	Screw (Air Guide Cover)	878	691237	Harness-Alternator
447A	690960	Screw (Air Guide Cover)	881	690999	Plate-Cover
462	691261	Washer (Starter Cable)	883	690970	+* Gasket-Exhaust
467	691008	Knob-Air Cleaner	914	690960	Screw (Rocker Cover)
474	691064	Alternator	918	691040	Hose-Vacuum
501	691185	Regulator	929	691003	Screw (Choke Control Bracket)
505	691029	Nut (Gov. Control Lever)	934	691058	Screw (Fan Retainer)
510	497606	Drive-Starter	943	690589	+ O-Ring Seal (Oil Pump Cover)
513	692024	Clutch-Drive	947	499809	Solenoid-Fuel
523	691036	Dipstick	965	499613	Oil Pump Cover
525	691037	Dipstick Tube	967	691016	Filter-Pre-Cleaner
526	690960	Screw (Regulator)	968	499788	Cover-Air Cleaner
544		Armature-Starter (Service with 691262 Starter Motor)	975	499810	Bowl-Float
			977	499812	Gasket Set-Carburetor
552	690552	Bushing-Governor Crank	987	691000	●◆ Seal-Throttle Shaft
552A	690553	Bushing-Governor Crank	993	690234	●◆ Gasket-Plate
556	691183	Screw (Alternator)	1005	691243	Fan-Flywheel
562	690311	Bolt (Gov. Control Lever)	1006	691247	Retainer-Fan
573	691009	Plate-Back	1013	690954	Nipple-Oil Filter
578	691208	Wire Assembly	1017	690770	Oil Pump Screen
579	691029	Nut (Starter Cable)	1019	690103	Label Kit
601	691038	Clamp-Hose	1022	690971	+* Gasket-Rocker Cover
615	690317	Retainer-Governor Shaft	1023	499599	Cover-Rocker (Cyl. No. 1)
616	691045	Crank-Governor	1023A	499600	Cover-Rocker (Cyl. No. 2)
628	690960	Screw (Fuel Pump Bracket)	1024	499054	Pump-Oil
633	690998	●◆ Seal-Choke Shaft	1026	690981	Rod-Push (Steel)
635	691210	Boot-Spark Plug	1026A	690982	Rod-Push (Aluminum)
654	690958	Nut (Carburetor)	1027	690041	Filter-Oil
668	691215	Spacer	1029	690972	Rocker Arm
691	690657	+Governor Shaft Seal	1033	499890	Valve Overhaul Kit
697	690372	Screw (Drive Cap)	1035	691042	Shaft-Pump
703	690010	Clip	1036	499783	Emissions Label
718	690959	Pin-Locator	1051	691265	Ring-Retaining
726	499612	Gear-Ring	1058	273694	Owner's Manual
741	690980	Gear-Timing	1081	691032	+ O-Ring Seal (Dipstick Tube)
742	690328	E-Ring Retainer	1090	691293	Retainer-Brush
750	691033	Screw (Oil Pump Cover)	1100	690973	Rocker Arm Pivot
783	693058	Gear-Pinion	1123	690987	●◆ O-Ring Seal (Solenoid Retainer)
788	691039	Fuel Pump Bracket	1124	690988	●◆ O-Ring Seal-Fuel Transfer Tube
789	691220	Harness-Wiring	1125	690990	● Screw (Cover Plate)
797	693167	Screw (Brush Retainer)	1126	690991	Screw (Fuel Transfer Tube)
798	690967	Screw (Rocker Arm)	1127	690992	Screw (Float Bowl)
801	691283	Cap-Drive	1128	690990	● Screw (Carburetor Nozzle)
802	691286	Cap-End	— —	407777-027-E1	Replacement Engine
803		Housing-Starter (Service with 691262 Starter Motor)			
847	499602	Dipstick/Tube Assembly	+		Included in Gasket Set, Ref. No. 358
851	691234	Terminal-Cable	●		Included in Gasket Set, Ref. No. 121
855	691011	Adapter-Air	*		Included in Gasket Set, Ref. No. 977
865	691012	Cover-Air Guide	*		Included in Gasket Set, Ref. No. 1033
865A	691014	Cover-Air Guide			
865B	691015	● Cover-Air Guide			

NOTE: All component dimensions given in U.S. inches
1 inch = 25.4 mm

SUGGESTED GUIDE FOR SIGHTING SLOPES FOR SAFE OPERATION

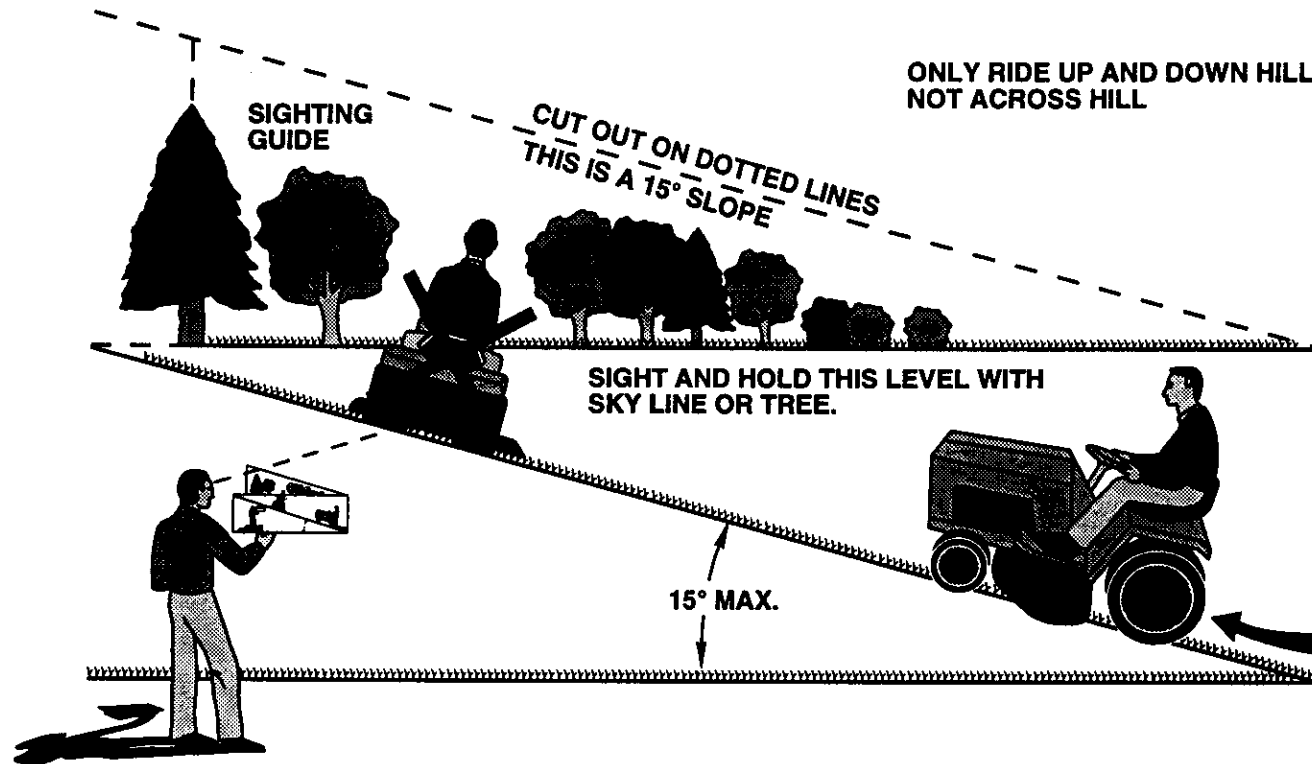

Operate your Tractor up and down the face of slopes (not greater than 15°), never across the face. Make turns gradually to prevent tipping or loss of control. Exercise extreme caution when changing direction on slopes.

For in-home major brand repair service:

Call 24 hours a day, 7 days a week

1-800-4-MY-HOMESM (1-800-469-4663)

Para pedir servicio de reparación a domicilio

1-800-676-5811

In Canada for all your service and parts needs call

Au Canada pour tout le service ou les pièces

1-800-665-4455

For the repair or replacement parts you need:

Call 6 am-11pm CST, 7 days a week

PartsDirectSM

1-800-366-PART (1-800-366-7278)

Para ordenar piezas con entrega a domicilio

1-800-659-7084

**For the location of a Sears Parts and Repair Center
in your area:**

Call 24 Hours a day, 7 days a week

1-800-488-1222

**For information on purchasing a Sears Maintenance
Agreement or to inquire about an existing Agreement:**

Call 9 am-5 pm, Monday - Saturday

1-800-827-6655

