



# OPERATOR'S MANUAL

Riding Mower  
Internal Bagging System  
27.5" Cutting Deck  
Model 247.270170  
Factory No. 13A-325-402



## IMPORTANT: READ SAFETY RULES AND INSTRUCTIONS CAREFULLY

**Warning:** This unit is equipped with an internal combustion engine and should not be used on or near any unimproved forest-covered, brush-covered or grass-covered land unless the engine's exhaust system is equipped with a spark arrester meeting applicable local or state laws (if any). If a spark arrester is used, it should be maintained in effective working order by the operator. In the State of California the above is required by law (Section 4442 of the California Public Resources Code). Other states may have similar laws. Federal laws apply on federal lands. A spark arrester for the muffler is available through your nearest engine authorized service dealer or contact the service department, P.O. Box 368022 Cleveland, Ohio 44136-9722.

**MTD PRODUCTS INC. P.O. BOX 368022 CLEVELAND, OHIO 44136-9722**

PRINTED IN U.S.A.

FORM NO. 770-10201  
(12/98)

## TABLE OF CONTENTS

Content	Page
Finding Model Number .....	2
Calling Customer Support Service .....	2
Safe Operation Practices .....	3
Slope Gauge .....	5
Unpacking .....	6
Contents of Hardware Pack .....	7
Assembly .....	8
Operation .....	12
Service & Adjustments .....	16
Maintenance .....	21
Off-Season Storage .....	23
Trouble-Shooting .....	24
Parts List .....	26

## FINDING MODEL NUMBER

This Operator's Manual is an important part of your new rider mower. It will help you assemble, prepare and maintain your rider mower. Please read and understand what it says.

Before you start to prepare your rider mower for its first use, please locate the model plate and copy the information from it in the space below. The information on the model plate is very important if you need help from your dealer or the MTD customer support department.

- Every rider mower has a model plate. You can locate it by pivoting the cover upward and looking under the frame. A sample model plate is shown below.

XXX-X-XXX-X-XXX    XXXXXXXXXXXXX

**MTD PRODUCTS INC**  
CLEVELAND, OHIO 44136

\_\_\_\_\_ This is where your model number will be.

\_\_\_\_\_ This is where your serial number will be.

Copy the model number here: \_\_\_\_\_

Copy the serial number here: \_\_\_\_\_

## CALLING CUSTOMER SUPPORT SERVICE

- **Locate your rider's model number and serial number** — Record this information in the space provided above. To find your unit's specific model number and serial number, see previous section.
- If you are having difficulty assembling this product or if you have any questions regarding the controls, operation or maintenance of this unit, please call the Customer Support Department. Customer Support can be reached by dialing: **1- 330- 220-4MTD (1-330-220-4683)**

or  
**1- (800)-800-7310**

- Please have your unit's model number and serial number ready when you call.
- Although both numbers are important, you will be asked to enter only the **serial** number before your call can be processed.

# SAFE OPERATION PRACTICES



This symbol points out important safety instructions which, if not followed, could endanger the personal safety and/or property of yourself and others. Read and follow all instructions in this manual before attempting to operate your rider mower. Failure to comply with these instructions may result in personal injury. When you see this symbol—heed its warning.



## **DANGER:**

Your rider mower was built to be operated **according to the rules for safe operation in this manual**. As with any type of power equipment, carelessness or error on the part of the operator can result in serious injury. **If you violate any of these rules, you may cause serious injury to yourself or others.**

## General Operation

- Read, understand, and follow all instructions in the manual and on the machine before starting. Keep this manual in a safe place for future and regular reference and for ordering replacement parts.
- Only allow responsible individuals familiar with the instructions to operate the machine. Know controls and how to stop the machine quickly.
- Do not put hands or feet under cutting deck or near rotating parts.
- Clear the area of objects such as rocks, toys, wire, etc., which could be picked up and thrown by the blade. A small object may have been overlooked and could be accidentally thrown by the mower in any direction and cause injury to you or a bystander. To help avoid a thrown objects injury, keep children, bystanders and helpers at least 75 feet from the mower while it is in operation. Always wear safety glasses or safety goggles during operation or while performing an adjustment or repair, to protect eyes from foreign objects. Stop the blade(s) when crossing gravel drives, walks or roads.
- Be sure the area is clear of other people before mowing. Stop machine if anyone enters the area. Never carry passengers.
- Disengage blade(s) before shifting into reverse and backing up. Always look down and behind before and while backing.
- Be aware of the mower and attachment discharge direction and do not point it at anyone. Do not operate the mower without either the entire grass catcher or the chute guard in place.
- Slow down before turning. Operate the machine smoothly. Avoid erratic operation and excessive speed.
- Never leave a running machine unattended. Always turn off blade(s), place transmission in neutral, set park brake, stop engine and remove key before dismounting.
- Turn off blade(s) when not mowing.
- Stop engine and wait until blade(s) comes to a complete stop before (a) removing grass catcher or unclogging chute, or (b) making any repairs, adjusting or removing any grass or debris.
- Mow only in daylight or good artificial light.
- Do not operate the machine while under the influence of alcohol or drugs.
- Watch for traffic when operating near or crossing roadways.
- Use extra care when loading or unloading the machine into a trailer or truck. This unit should not be driven up or down a ramp onto a trailer or truck under power, because the unit could tip over, causing serious personal injury. The unit must be pushed manually on a ramp to load or unload properly.
- Never make a cutting height adjustment while engine is running, if operator must dismount to do so.
- Wear sturdy, rough-soled work shoes and close-fitting slacks and shirts. Do not wear loose fitting clothes or jewelry. They can be caught in moving parts. Never operate a unit in bare feet, sandals, or sneakers.
- Check overhead clearance carefully before driving under power lines, wires, bridges or low hanging tree branches, before entering or leaving buildings, or in any other situation where the operator may be struck or pulled from the unit, which could result in serious injury.
- Disengage all attachment clutches, thoroughly depress the brake pedal, and shift into neutral before attempting to start engine.
- Your mower is designed to cut normal residential grass of a height no more than 10". Do not attempt to mow through unusually tall, dry grass (e.g., pasture) or piles of dry leaves. Debris may build up on the mower deck or contact the engine exhaust presenting a potential fire hazard.

## Slope Operation

Slopes are a major factor related to loss of control and tip-over accidents which can result in severe injury or death. All slopes require extra caution. If you cannot back up the slope or if you feel uneasy on it, do not mow it.

For your safety, use the slope gauge included as part of this manual to measure slopes before operating this unit on a sloped or hilly area. If the slope is greater than 15° as shown on the slope gauge, do not operate this unit in that area or serious injury could result.

### **Do:**

- Mow up and down slopes, not across.
- Remove obstacles such as rocks, limbs, etc.
- Watch for holes, ruts or bumps. Uneven terrain could overturn the machine. Tall grass can hide obstacles.
- Use slow speed. Choose a low enough gear so that you will not have to stop or shift while on the slope. Always keep machine in gear when going down slopes to take advantage of engine braking action.
- Follow the manufacturer's recommendations for wheel weights or counterweights to improve stability.

- Use extra care with grass catchers or other attachments. These can change the stability of the machine.
- Keep all movement on the slopes slow and gradual. Do not make sudden changes in speed or direction. Rapid engagement or braking could cause the front of the machine to lift and rapidly flip over backwards which could cause serious injury.
- Avoid starting or stopping on a slope. If tires lose traction, disengage the blade(s) and proceed slowly straight down the slope.

#### **Do Not:**

- Do not turn on slopes unless necessary; then, turn slowly and gradually downhill, if possible.
- Do not mow near drop-offs, ditches or embankments. The mower could suddenly turn over if a wheel is over the edge of a cliff or ditch, or if an edge caves in.
- Do not mow on wet grass. Reduced traction could cause sliding.
- Do not try to stabilize the machine by putting your foot on the ground.
- Do not use grass catcher on steep slopes.

#### **Children**

Tragic accidents can occur if the operator is not alert to the presence of children. Children are often attracted to the machine and the mowing activity. Never assume that children will remain where you last saw them.

- Keep children out of the mowing area and in watchful care of an adult other than the operator.
- Be alert and turn machine off if children enter the area.
- Before and when backing, look behind and down for small children.
- Never carry children. They may fall off and be seriously injured or interfere with the safe machine operation.
- Never allow children under 14 years old to operate the machine. Children 14 years and over should only operate machine under close parental supervision and proper instruction.
- Use extra care when approaching blind corners, shrubs, trees or other objects that may obscure your vision of a child or other hazard.
- Remove key when machine is unattended to prevent unauthorized operation.

#### **Service**

- Use extreme care in handling gasoline and other fuels. They are extremely flammable and the vapors are explosive.
  - a. Use only an approved container.
  - a. Never remove fuel cap or add fuel with the engine running. Allow engine to cool at least two minutes before refueling.
  - b. Replace fuel cap securely and wipe off any spilled fuel before starting the engine as it may cause a fire or explosion.
  - c. Extinguish all cigarettes, cigars, pipes and other sources of ignition.
  - d. Never refuel the machine indoors because fuel vapors will accumulate in the area.

- e. Never store the fuel container or machine inside where there is an open flame or spark, such as a gas hot water heater, space heater or furnace.
- Never run a machine inside a closed area.
- To reduce fire hazard, keep the machine free of grass, leaves or other debris build-up. Clean up oil or fuel spillage. Allow machine to cool at least 5 minutes before storing.
- Before cleaning, repairing or inspecting, make certain the blade and all moving parts have stopped. Disconnect the spark plug wire, and keep the wire away from the spark plug to prevent accidental starting.
- Check the blade and engine mounting bolts at frequent intervals for proper tightness. Also, visually inspect blade for damage (e.g., excessive wear, bent, cracked). Replace with blade which meets original equipment specifications.
- Keep all nuts, bolts and screws tight to be sure the equipment is in safe working condition.
- Never tamper with safety devices. Check their proper operation regularly. Use all guards as instructed in this manual.
- After striking a foreign object, stop the engine, remove the wire from the spark plug and thoroughly inspect the mower for any damage. Repair the damage before restarting and operating the mower.
- Grass catcher components are subject to wear, damage and deterioration, which could expose moving parts or allow objects to be thrown. For your safety protection, frequently check components and replace with manufacturer's recommended parts when necessary.
- Mower blades are sharp and can cut. Wrap the blade(s) or wear gloves and use extra caution when servicing blade(s).
- Check brake operation frequently. Adjust and service as required.
- Muffler, engine and belt guards become hot during operation and can cause a burn. Allow to cool down before touching.
- Do not change the engine governor settings or overspeed the engine. Excessive engine speeds are dangerous.
- Observe proper disposal laws and regulations. Improper disposal of fluids and materials can harm the environment and the ecology.
  - a. Prior to disposal, determine the proper method to dispose of waste from your local office of Environmental Protection Agency. Recycling centers are established to properly dispose of materials in an environmentally safe fashion.
  - b. Use proper containers when draining fluids. Do not use food or beverage containers that may mislead someone into drinking from them. Properly dispose of the containers immediately following the draining of fluids.
  - c. DO NOT pour oil or other fluids into the ground, down a drain or into a stream, pond, lake or other body of water. Observe Environmental Protection Agency regulations when disposing of oil, fuel, coolant, brake fluid, filters, batteries, tires and other harmful waste.

# SLOPE GAUGE

USE THIS PAGE AS A GUIDE TO DETERMINE SLOPES WHERE YOU MAY NOT OPERATE SAFELY:

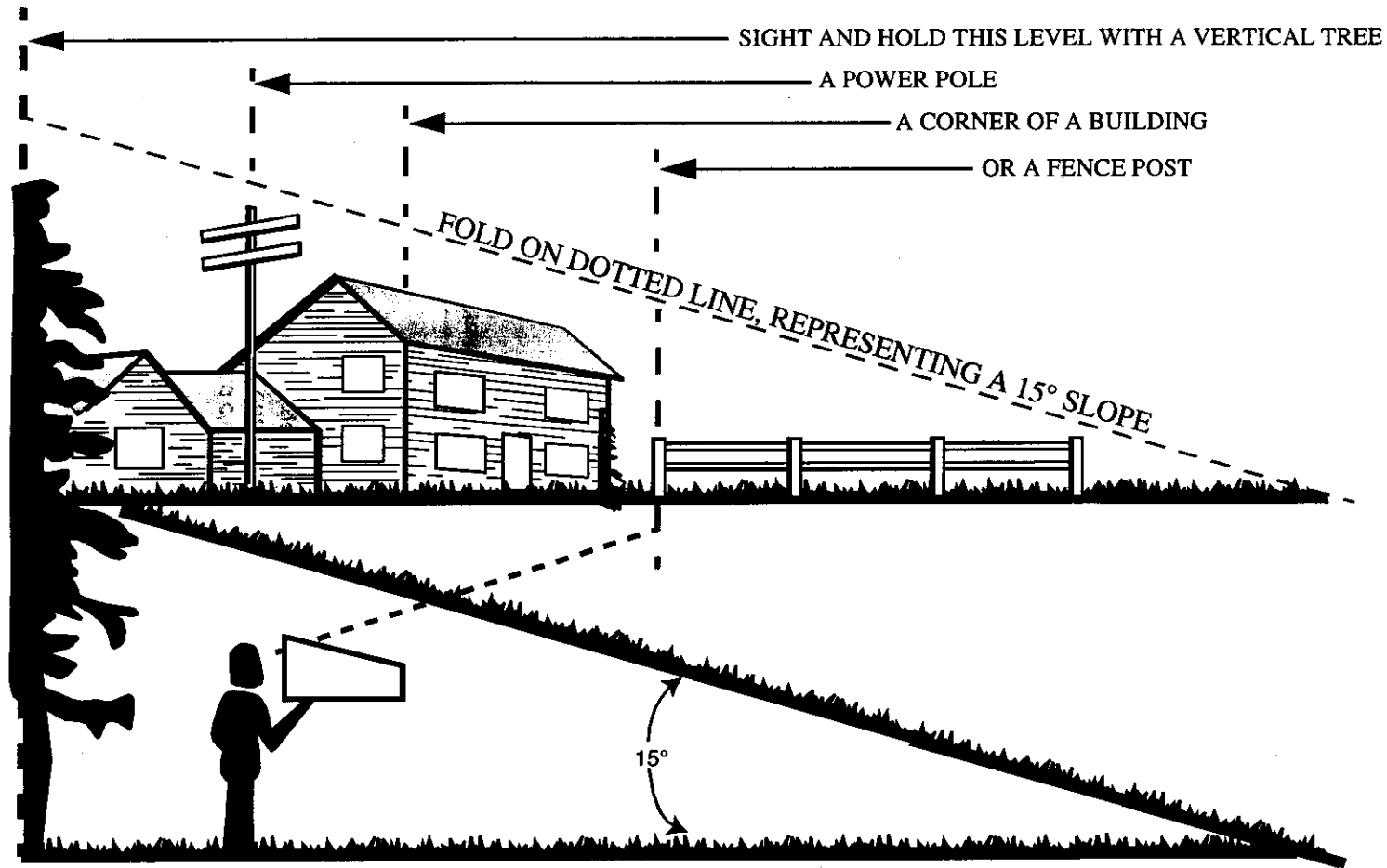

## WARNING

Do not mow on inclines with a slope in excess of 15 degrees (a rise of approximately 2-1/2 feet every 10 feet). A riding mower could overturn and cause serious injury. If operating a walk-behind mower on such a slope, it is extremely difficult to maintain your footing and you could slip, resulting in serious injury. Operate RIDING mowers up and down slopes, never across the face of slopes. Operate WALK-BEHIND mowers across the face of slopes, never up and down slopes.

# UNPACKING

## Removing From Crate

- Remove all screws from bottom of the crate using a 1/4" socket or a flat blade screwdriver.
- Holding the sides of the crate firmly, lift the crate up and keep it aside. Avoid tire punctures.
- Remove and discard plastic bag which covers the unit.
- Lift the rear of the mower and clear the bottom of the crate. Repeat for the front.
- Be sure parking brake is disengaged; roll unit out of the crate's way.

## Loose Parts

You will find the following loose parts in the crate. To identify these parts, see Figure 1. Remove loose parts very carefully so as not to damage or lose any.

1. Steering wheel components: steering wheel, cap, shaft, tube
2. Operator's manual (not shown in Figure 1)
3. Mulching plug & side-discharge chute
4. Oil drain sleeve
5. Battery acid pack\* (not shown in Figure 1)
6. Battery cover
7. Ignition keys (not shown in Figure 1)
8. Steering gear cover
9. Bumper (optional)
10. Hitch Plate (optional)

\* Not included as loose part if unit shipped with wet battery

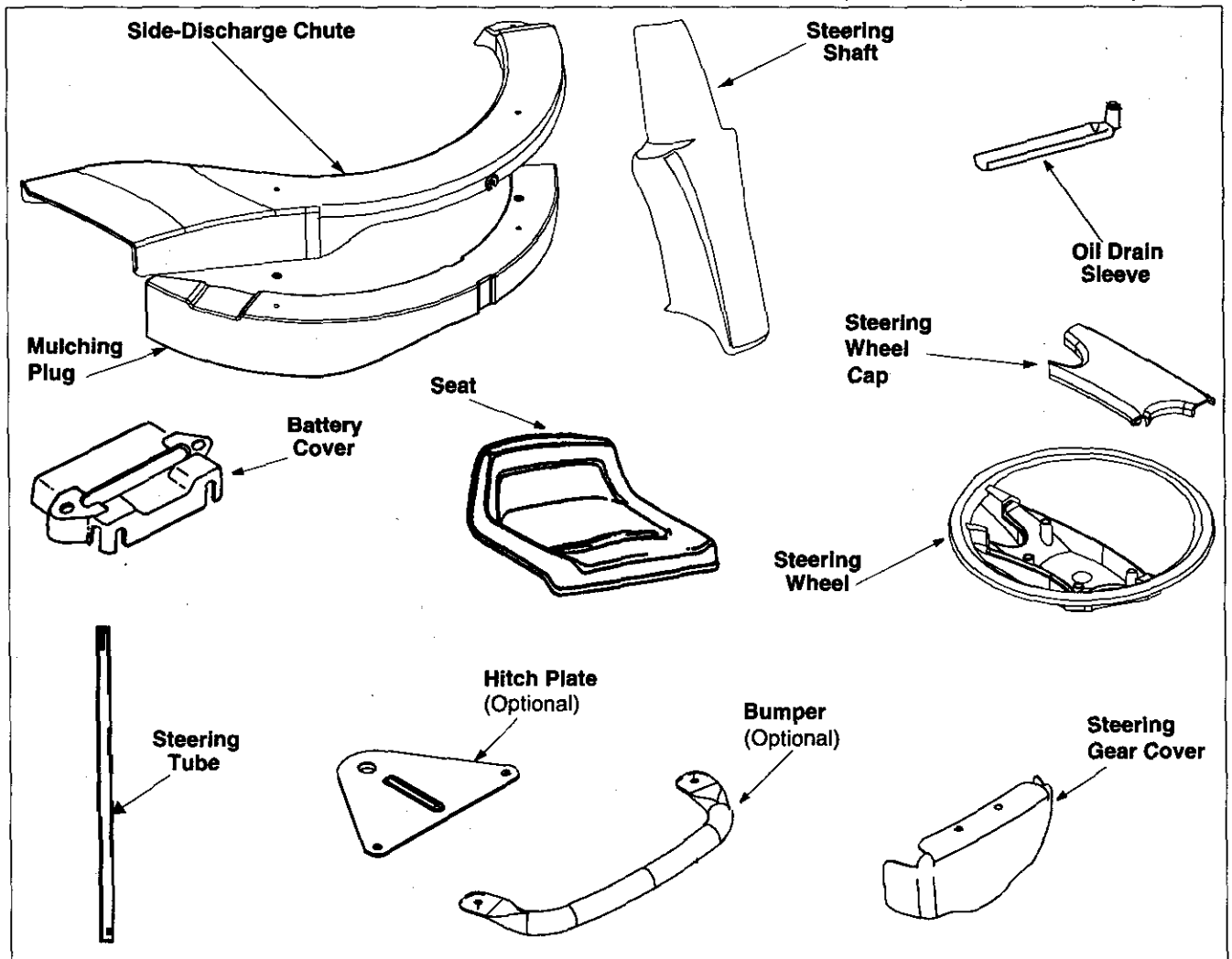

Figure 1

# Contents of Hardware Pack

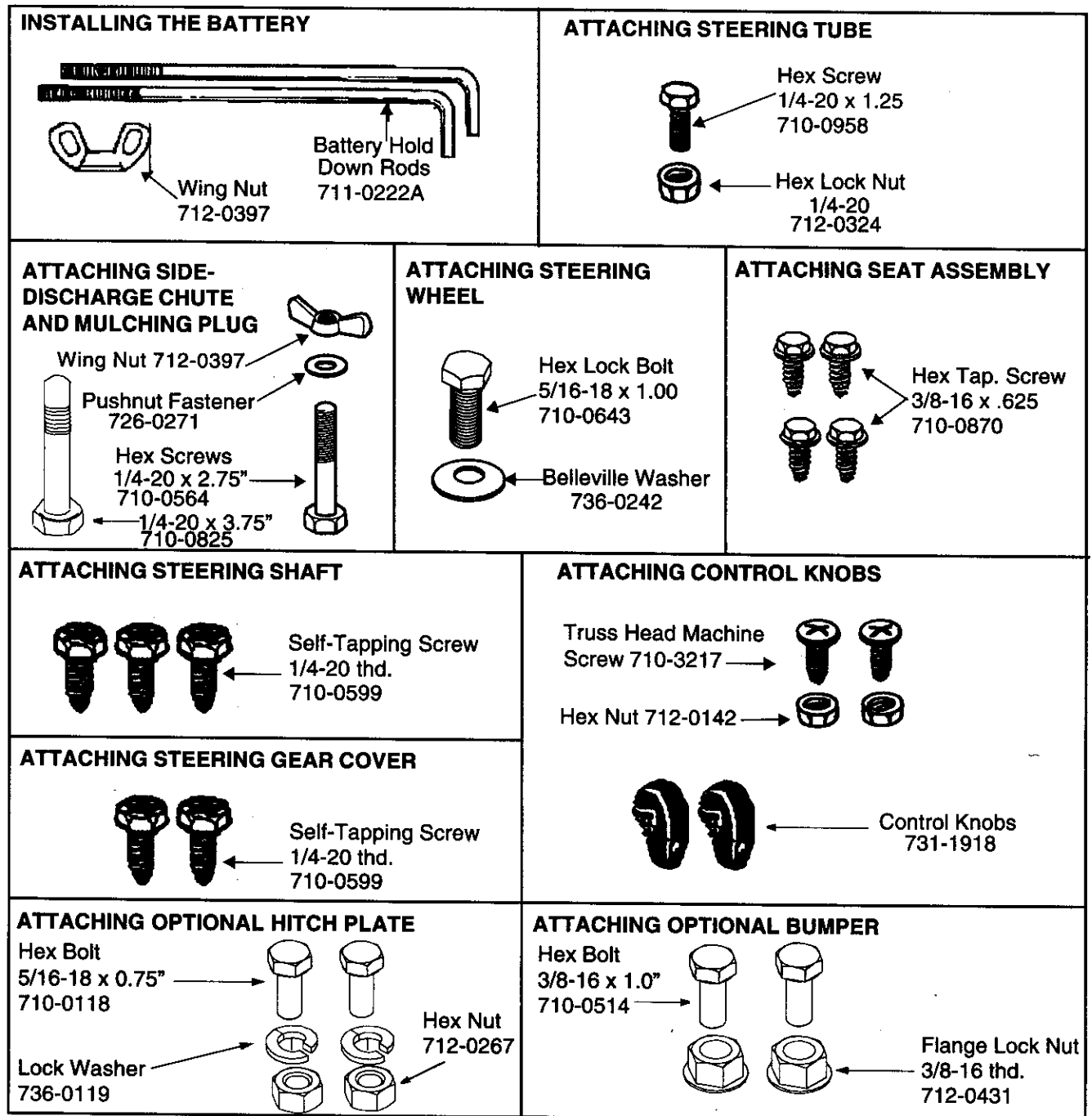

Figure 2

**NOTE:** Reference to front, rear, right or left hand side of the mower is observed from the operating position.

## Items Required For Assembly

1. Fresh Gasoline
2. 7/16" wrench or socket (2)
3. 1/2" socket (1)
4. 9/16" wrench or socket (1)
5. Phillips head screwdriver (1)
6. Flat head screwdriver (1)

**IMPORTANT:** This unit is shipped **WITHOUT GASOLINE** in the engine. Be certain to service engine with gasoline as instructed in the separate engine manual before operating your mower.

- All hardware necessary for assembling your rider mower is included in the hardware pack. See Figure 2 and get familiar with the hardware before starting to assemble unit.

# ASSEMBLY

## Installing Battery



**WARNING:** Battery acid must be handled with great care as **contact with it can burn and blister** the skin. Wear protective clothing (goggles, rubber gloves and apron) when working with it.

Always shield eyes, protect skin and clothing when working near batteries.

Always keep battery **out of reach of children**.

Should battery acid **accidentally splatter into the eyes** or onto the face, rinse the affected area immediately with clean cold water. If there is any further discomfort, seek prompt medical attention.

If **acid spills on clothing**, first dilute it with clean water, then neutralize with a solution of ammonia/ water or baking soda/water.

Since **battery acid is corrosive**, do not pour it into any sink or drain. Before discarding empty electrolyte containers, rinse them with a neutralizing solution.

Never connect or disconnect charger clips to battery while charger is turned on as it **can cause sparks**.

Keep all lighted materials (cigarettes, matches, lighters) away from the battery as the hydrogen gas generated during charging **can be combustible**.

As a further precaution, **only charge the battery in a well-ventilated area**. Make certain venting path of battery (drain tube) is always open.

### Antidote

**External:** Flush with water.

**Internal:** Drink large quantities of water or milk. Follow with milk of magnesia, beaten eggs or vegetable oil. Seek medical help immediately.

**Eyes:** Flush with cool water for at least 15 minutes, then get prompt medical attention.

## Activating the Battery

**IMPORTANT:** *If your rider mower was shipped with a wet battery, that is with the battery already filled with electrolyte, skip the battery set-up section entirely and go to "Installing the Battery" section on page 9.*

**NOTE:** *Continue assembling the rider mower while the battery is standing for 30 minutes (after filling with acid), and later while you are charging the battery.*

Follow the safety precautions mentioned previously. Also remember to take added precaution, as stated below, while activating the battery.



**WARNING:** When not in use, keep the terminal covers in place.

Do not short battery terminals (avoid a connection between the two battery posts or between the positive terminal and the frame of the riding mower).

Before installing battery, remove metal bracelets, wristwatch bands, rings, etc. from your person.

Connect positive terminal first to prevent sparks from accidental grounding.

Do not use the rider mower battery to start other vehicles.

- Carefully remove electrolyte (battery fluid, acid) pack from its box.
- Using a flat head screwdriver, remove the cell caps from the battery.
- Open the carton containing the electrolyte (acid) pack pouch. Cut 1/4" from the spout on top of the acid pack.
- Fill each cell of the battery up to the split ring. Do not exceed the maximum fill level.
- Allow the battery to stand for 30 minutes with the caps off. The electrolyte level may drop due to the chemical reaction in the battery. Add if necessary.
- Do not overfill the battery. Overfilling the battery can cause leakage which can damage your new rider mower.
- Replace the cell caps on the battery.

## Charging the Battery



**WARNING:** While charging the battery, **do not smoke**. Keep the battery away from any sparks. The fumes from the battery acid **can cause an explosion**.

After the battery has been charged, **add only distilled water**. Do not add acid.

- After filling with acid the battery has reached 85% charging capacity. A newly activated battery will reach 100% capacity in 1 to 2.5 hours with a 3 ampere charge.



- A battery charged by the alternator will have the same life as a battery bench charged prior to installation provided that the engine is run for 1 to 2.5 hours with a 3 ampere alternator for the initial charge.

**NOTE:** After battery has been charged, add only distilled water. Do not add electrolyte (battery fluid, acid).

#### Disposing of electrolyte

After filling the cells to the proper level, you may have some extra electrolyte (battery fluid, acid) left over. Follow the steps below for proper disposal.

- Fill the plastic container halfway with tap water. Put two tablespoons of baking soda in the electrolyte/water mix. Fill rest of the container with water.
- Pour the baking soda, water and electrolyte mix down the sink drain under running water.
- Throw the plastic container in the garbage.

**NOTE:** The information listed above is for initial charge. Refer to the Maintenance section of this manual for battery care and charging instructions after regular usage.

#### Installing the battery

- Pivot the cover of the mower upwards as shown in Figure 3.

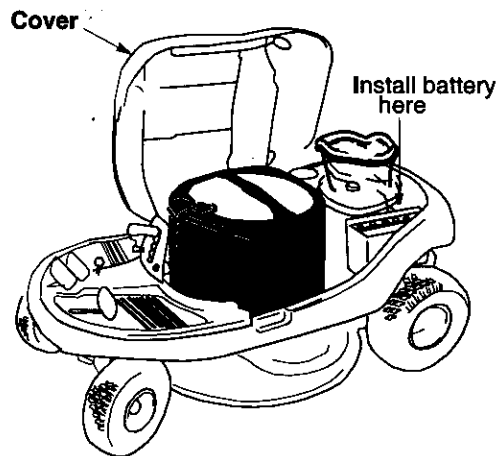

Figure 3

- Place the battery into the battery opening with positive terminal toward the rear of the unit. Make certain both the negative (black) cable and the positive (red) cable are routed up through the battery opening. See Figure 4.
- Attach the positive (red) cable to the positive terminal of the battery. See Figure 4. Secure with hex bolt and nut provided with the battery. Slide rubber boot over the positive terminal.
- Attach negative cable to the negative terminal with a hex bolt and nut provided. See Figure 4.
- Hook the curved end of the hold-down rod

through the hole in the battery tray.

- Pull up on the hold-down rods through the holes on the battery cover and insert one wing nut on each hold-down rod. Tighten the two wing nuts to secure the battery to the unit. See Figure 4.

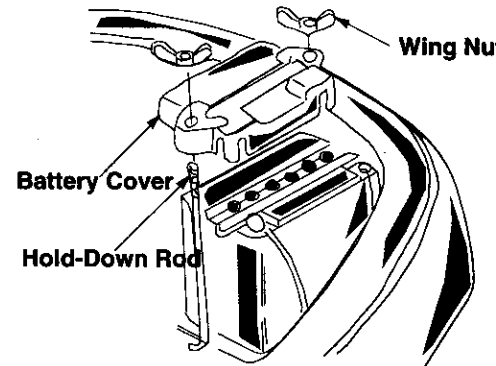

Figure 4

#### Attaching Steering Tube

- Slide the steering tube into the steering support bracket assembly.
- Secure with hex screw and hex inserted lock nut from the hardware pack. See Figure 5.

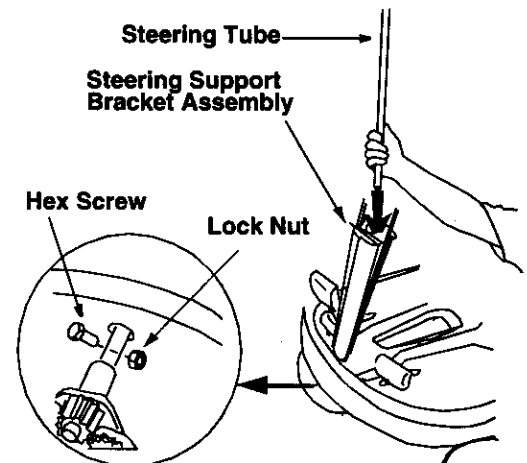

Figure 5

#### Attaching Steering Gear Cover, Optional Bumper & Optional Hitch Plate

- Align the two holes on the steering gear cover with the two corresponding holes on the front frame of the rider. See Figure 6A.
- Insert two self-tapping screws from the hardware pack through these two holes of the gear cover and the frame as shown in Figure 6A. Secure tightly.
- If your rider mower is equipped with the optional **Bumper**, align the two holes at the ends of the tube with the corresponding holes on the front of the rider. See Figure 6B. Insert the two hex bolts from hardware pack as shown and secure with the lock nut.

- Align the holes on the hitch plate with the holes on the rear frame assembly as shown in Figure 6C. Secure on each side with hex bolt, lock washer and hex nut from the hardware pack.

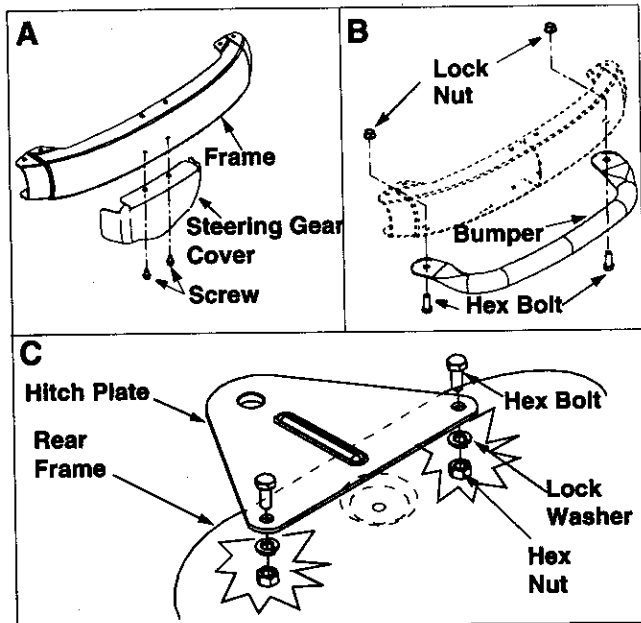

Figure 6

### Attaching Steering Shaft

- Slide the steering shaft over the steering tube and secure with three self-tapping screws from the hardware pack. See Figure 7.

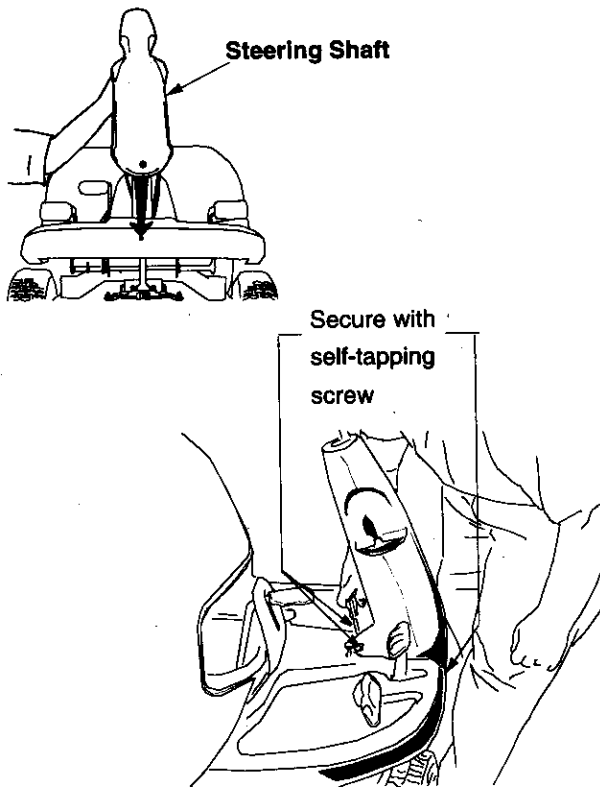

Figure 7

### Attaching Control Knobs

- Attach control knobs to the shift lever and throttle/choke control lever using truss head machine screws and hex nuts. See Figure 8.

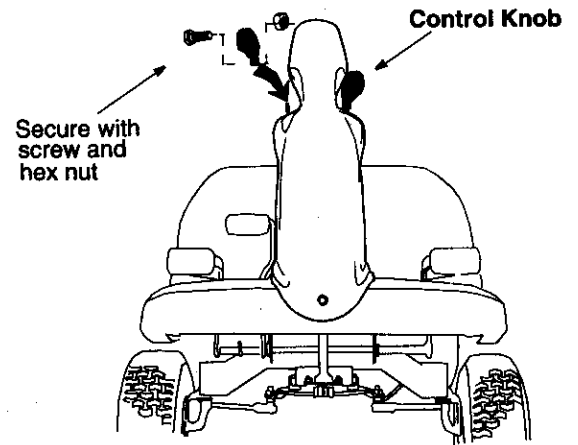

Figure 8

### Attaching Steering Wheel

- With the wheels of the tractor pointing straight forward, place the steering wheel over the steering shaft, positioning the steering wheel as desired. See Figure 9.
- Place the bell washer with the cupped side down over the steering shaft. Secure with hex lock bolt.
- Press the steering wheel insert onto the steering wheel aligning the four tabs in the rear of the steering wheel insert with the four slots in the steering wheel so that the cap fits snugly. See Figure 9.

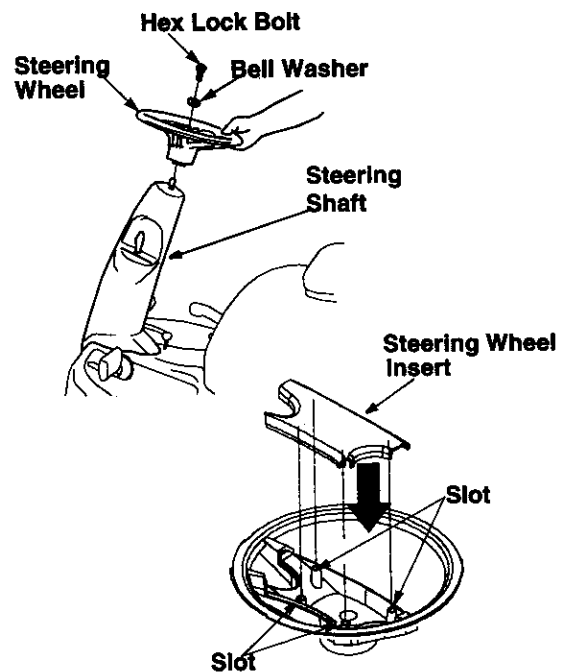

Figure 9

## Attaching Side Discharge Chute

Your riding mower is shipped to you with the grasscatcher fully assembled on the unit. A side discharge chute and a mulching plug are included as loose parts. Follow the instructions below to attach the side-discharge chute.



**WARNING:** Do not operate the mower if any one of the grasscatcher, discharge chute or mulching plug is not firmly installed on the mower.

- Pivot the cover up and lower the cutting height adjustment lever to the lowest position.
- Remove the two wing nuts (A and B in Figure 10) from two ends of the grasscatcher chute.

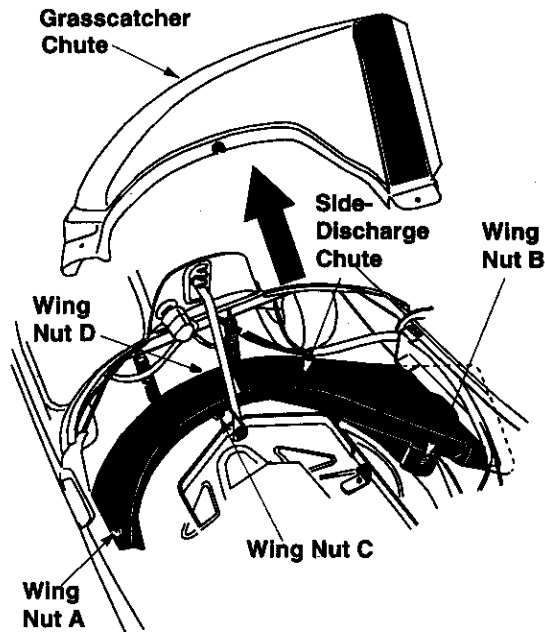

Figure 10

- Loosen the two wing nuts (C and D in Figure 10) in the middle of the chute. Do not remove. All four wing nuts (A, B, C, and D) hold the chute to the deck frame.
- Slide the grasscatcher chute to the right and out of the deck frame.
- Slide the side-discharge chute in and place it on the deck so that the four wing nut positions align with those on the deck.
- Reinsert wing nuts A and B that you had earlier removed. Tighten to secure.
- Tighten the two wing nuts C and D. Check and make sure that the side-discharge chute is properly installed and the hardware tightly secured.

## Attaching Mulch Plug

While operating your rider mower, you have three options: (i) to collect grass clippings in the grasscatcher, (ii) to discharge grass clippings on the

side, or (iii) to mulch grass and recirculate clippings back to the lawn. For the third option, attach the mulching plug to the side-discharge chute and then to the deck.

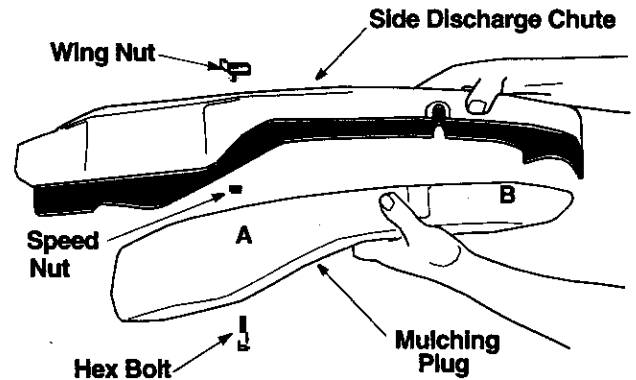

Figure 11

- To assemble the mulching plug, put two hex bolts through the mulching plug at the respective openings.
- Place speed nuts over the hex bolts.
- Insert the plug into the side discharge chute aligning the two slots on the two sides of the side-discharge chute with those on the mulching plug. See Figure 11.
- Place wing nut on each of the hex bolts and thread a few turns. Check that the plug is aligned correctly within the discharge chute.
- Tighten both wing nuts
- To attach the mulching plug now to the unit, follow instructions to attach side discharge chute to the deck.

## Installing Seat and Safety Switch

- Pivot the cover of the mower upwards.
- Align the slots in the frame with the four holes on the bottom of the seat and secure with four self-tapping screws. See Figure 12.
- Align the tabs on the safety switch with the large cut-out on the bottom of the seat, push the safety switch in and turn clockwise to lock. See Figure 12.

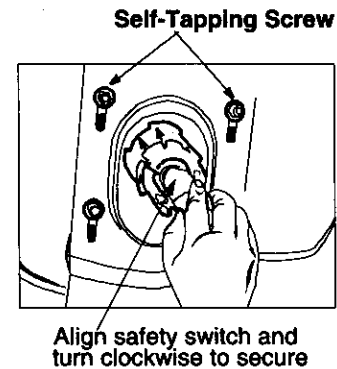

Figure 12

# OPERATION

## Know Your Rider Mower

Compare the illustrations on this page with your rider mower to familiarize yourself with the location of various controls and adjustments. The operation of any rider mower can result in foreign objects being thrown into the operator's eyes, causing severe eye damage. **Always wear safety glasses** before operating the mower, or while performing any adjustments or repairs on it.

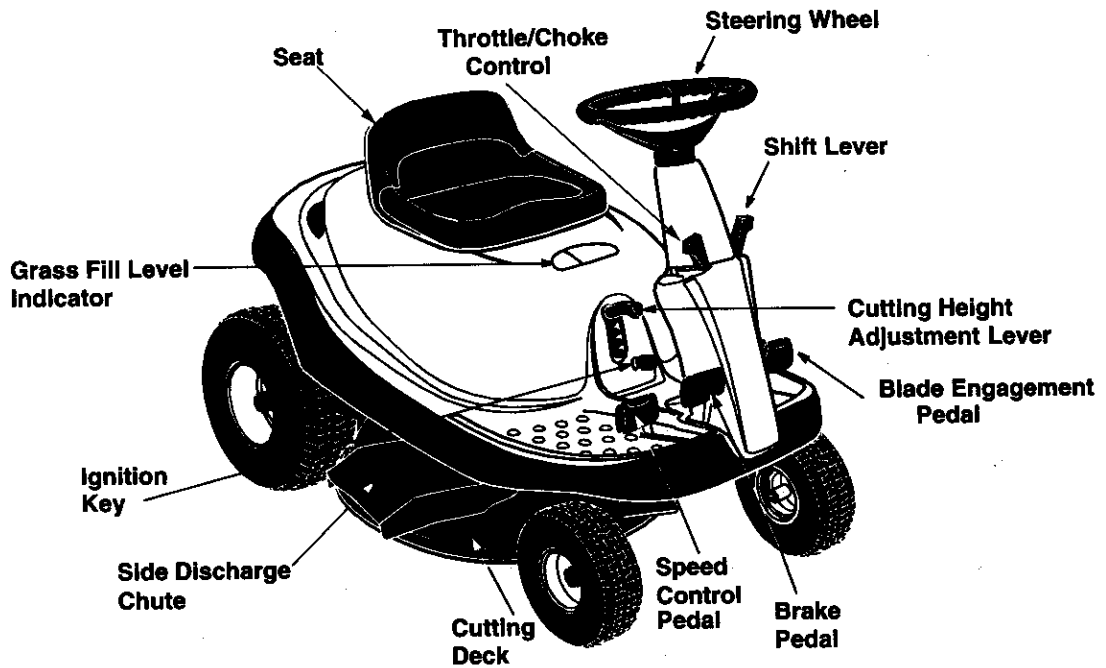

Figure 13

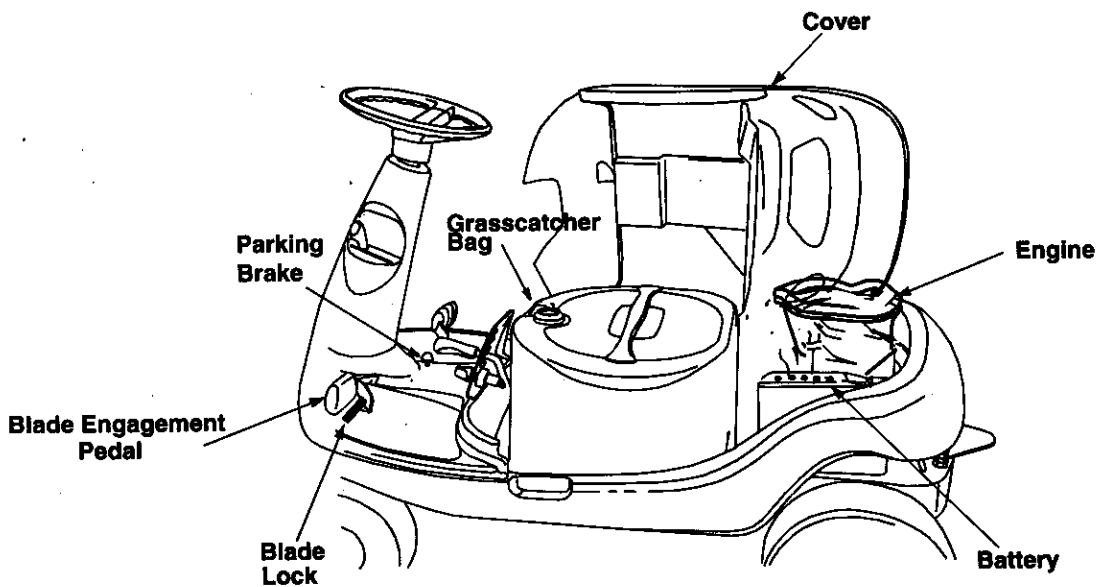

Figure 14

## Know the Controls

(Refer to Figure 13 and Figure 14.)

**Throttle/Choke Control:** Use to regulate the engine speed and to start the engine.

**Speed Control Pedal:** Use to regulate the ground speed of the rider mower.

**Ignition Switch:** Use to turn the engine ON or OFF.

**Shift Lever:** Use to change direction of the mower.

**Grass Fill Level Indicator:** Use to determine the level of grass clipping in the bag and when to stop and empty it.

**Parking Brake:** Use to stop the mower from moving while parked.

**Blade Engagement Pedal:** Use to engage or disengage the blade.

**Blade Lock:** Use to lock blade at the engaged position.

**Cutting Height Adjustment Lever:** Use to raise and lower the cutting deck which determines the cutting height.

**Brake Pedal:** Use to stop the mower's forward or reverse motion.

## Safety Interlock

This unit is equipped with a safety interlock system for your protection. The interlock safety switches are connected to the brake pedal, the blade engagement pedal, the shift lever, and the seat.

The purpose of the safety interlock system is threefold:

- a. to prevent the engine from starting unless the brake pedal is depressed and the blade engagement pedal is disengaged;
- b. to shut off the engine if the blade pedal is not disengaged when the shift lever is put into **reverse**; and
- c. to shut the engine off when the operator leaves the seat without engaging the parking brake.



**WARNING:** To avoid the risk of serious injury, do not operate the rider mower if the interlock system is malfunctioning.

## To Maintain Safety



**WARNING:** It is very important that you maintain safety while operating your rider mower. Observing the caution rules mentioned below will enable you to enjoy your rider mower.

- Avoid serious injury or death.
- Go up and down slopes, not across.
- Avoid sudden turns.
- Do not operate the unit where it could slip or tip.

- If your rider mower stops while going uphill, stop the blade(s) and reverse downhill slowly.
- Do not mow when children or others are around. **Never carry children.**
- Look down and behind before and while reversing.
- Keep safety devices (guards, shields, and switches) in place and working.
- Remove objects that could be thrown by the blade(s).
- Know location and function of all controls.
- Be sure blade(s) and engine are stopped before placing hands or feet near blade(s).
- Before leaving operator's position, disengage blade(s), place the shift lever in neutral, engage parking brake, shut engine off and remove key.

## Stopping Mower

- Release blade engagement pedal all the way.
- Release the speed control pedal and depress the brake pedal.
- When the mower comes to a complete stop, place the shift lever in neutral.
- Engage the parking brake by pulling up on the parking brake knob.
- Turn the ignition key to OFF position and remove the key.

## Using Throttle/Choke Control

The throttle/choke control is used to increase or decrease the speed of the engine. The FAST and the SLOW positions are marked with illustrations of a rabbit and a turtle respectively. See Figure 15.

- For normal operation and when using a grasscatcher, move the throttle/choke control to the FAST position.
- For maximum charging of the battery and also for a cooler engine while running, move the throttle/choke control to the FAST position.
- For transport and to tow pull-behind attachments, move the throttle/choke control to the SLOW position.
- Do not adjust the governor to increase or decrease the engine speed. The governor is set at the factory for maximum engine performance, and should not be altered.

## Using Shift Lever

The shift lever is used to regulate the direction of your rider mower. It can be set at forward, neutral, or reverse settings. These settings, marked as F, N, and R respectively, are located next to the shift lever on the unit. See Figure 15.

- Before you move the shift lever to any of the positions, depress the brake pedal and stop the unit. Keep your foot on the brake pedal.

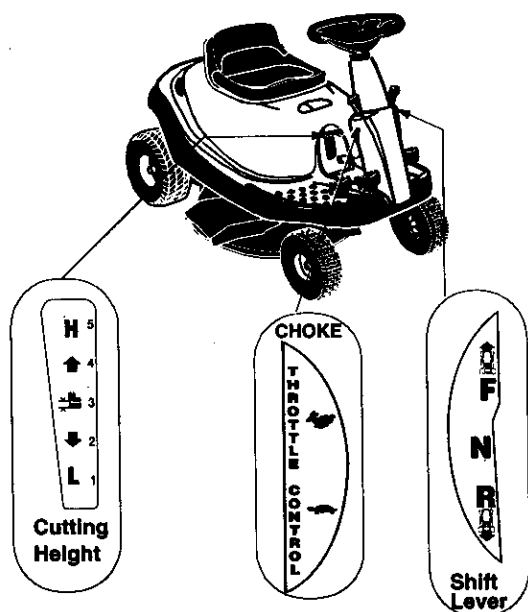

Figure 15

- Move the lever outwards (left) to remove the locking pin from the lever and slide the lever to the position desired. Look at the rear and make sure the path is free of obstacles before positioning the shift lever to the reverse.
- Do not force the shift lever. If it does not shift, release the brake pedal slightly to line up the shifting collar in the transmission, then try to move the shift lever.
- Slowly release the brake pedal and take your foot off the pedal. Always make sure that there is no one in the way when you run the mower.

### Adjusting Cutting Height

The deck cutting height adjustment lever is located on the cover. For a representation of the cutting height positions, refer to Figure 15.

- Pull the lever out of the slot and slide it upward or downward to the desired cutting height.
- Lower the cutting height to mow close to the ground.
- Raise the deck height to the highest position when you ride on a sidewalk or a road.
- To mow tall or thick grass, move the cutting height adjustment lever to the highest position and cut. Then move the lever to a lower position and cut again.

### Using Parking Brake

#### To engage parking brake

- Completely push the brake pedal down and stop the unit.
- With your right foot on the brake pedal, move the shift lever to the neutral position.
- Continuing to hold down the brake pedal with your right foot, pull up the parking brake knob. Make sure the parking brake holds the unit.

- Release the brake pedal. Stop the engine and remove the ignition key. Now your rider mower is parked.

#### To release the parking brake

- Depress the brake pedal. The parking brake will be automatically disengaged.

### Before Starting

Service the engine with gasoline as described in the engine manual.



Never fill fuel tank indoors, or when engine is running or hot. Do not smoke while filling up the gasoline tank.

### Starting Engine

(Refer to Figure 16.)

- Attach the wire to the spark plug.
- Depress the brake pedal with your right foot.
- Set throttle/choke control in the CHOKE position (all the way forward).
- Place the shift lever in the NEUTRAL position.
- Turn the ignition key to the START position. As soon as the engine starts, let the key return to the ON position.
- Move throttle/choke control out of CHOKE position and into FAST throttle position.

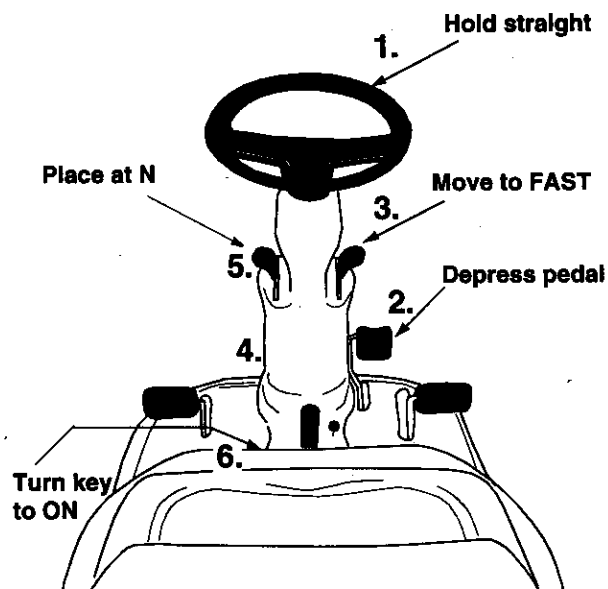

Figure 16

### Starting Mower

- Depress the brake pedal so that the parking brake is disengaged.
- Place the shift lever in either the FORWARD or the REVERSE position as you desire. **Look to the rear and check before backing up.**
- Release the brake pedal.
- Depress the speed control pedal.

- To stop, release the speed control pedal and depress the brake pedal.
- Press the blade engagement pedal downward until the blades are turning. The blades can be engaged either while the mower is in motion or while it is standing.

Your rider mower is equipped with a blade lock to keep the blade engaged without the operator having to depress the blade pedal continuously.

- **To engage the blade lock:** While pressing down on the blade pedal, push the blade lock down with your heel. It should click into the "blade engaged" position. To disengage the blade lock, simply push down on the blade pedal and release the lock.



**WARNING:** When the blades are engaged, keep feet and hands away from the discharge opening, the blades or any part of the deck.

### Stopping Mower

- Release blade engagement pedal all the way.
- Release the speed control pedal and depress the brake pedal.
- When the mower comes to a complete stop, place the shift lever in neutral.
- Engage the parking brake by pulling up on the parking brake knob.
- Turn the ignition key to OFF position and remove the key.

**NOTE:** Do not leave the key in the ON position when you are not operating the mower. Such action will drain the battery dead.

### Grass Fill Level Indicator

This indicator was designed to add convenience to your riding mower. While the mower is running, air will flow through the discharge chute and into the grass catcher. If the grass catcher is **empty**, air flows through easily pushing the ball up. If the grass catcher is **full**, air does not flow through it allowing the ball to fall. So if you see the white ball in the grasscatcher fill level indicator falling down, you should stop the mower and empty the bag.

### To Empty Grasscatcher

- Stop the mower completely, pull up on the parking brake knob and take the ignition key out. Get off the operator's seat.
- Pivot the cover up. Pull up the grasscatcher bag by the handle and take it to the proper disposal site. See Figure 17.
- Hold the bag away from your body. Push down on the bag lever and let the bottom section of the bag fall downwards. The grass clippings will be disposed of from the bottom. See Figure 17.

- Tap the bag on the ground so that the three legs of the bag press against the ground. The bag lever should snap close while you push the bag downwards.
- Replace the bag on to the mower making sure the bag is placed on the flange on top of the discharge chute. Pivot the cover down.

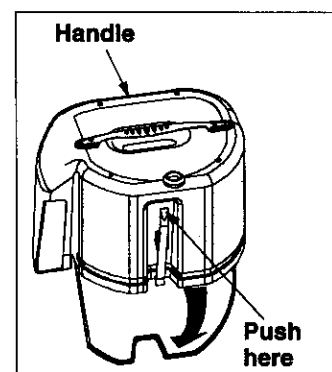
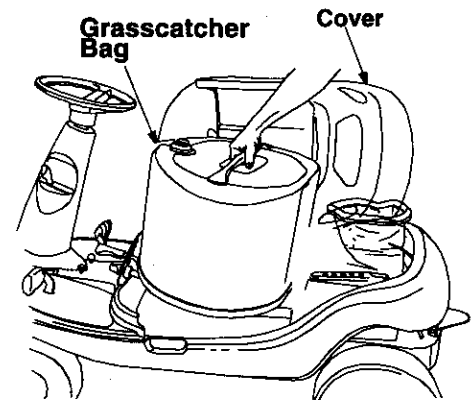

Figure 17

### Using The Mower

Observe the safety rules listed on pages 3-5 and 13 of this manual for safe operation of your mower.

- Before mowing, make sure that the cutting deck is leveled. For deck adjustment, refer to page 20.
- You can engage the blade by pressing on the blade engagement pedal with your left foot while sitting on the operator's seat.
- When mowing an area for the first time, watch out for objects lying on the grass. If you strike a foreign object, stop the engine. Remove wire from spark plug and thoroughly inspect the mower for any damage. Repair the damage before operating it again.
- Avoid scalping the lawn by adjusting the cutting height upwards and/or sharpening the blades.
- Mow at full throttle. Learn the terrain on which you are mowing. For best mowing results, mow only when the grass is dry.

- The recommended mowing pattern is given below:

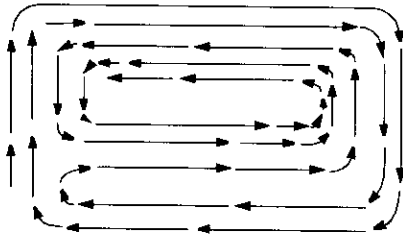

- Mow grass often and in regular intervals so that you can cut only 1/3 of the grass blade in one mowing.
- To empty grass bag, **stop the mower completely**, engage the parking brake, and

- turn the ignition off. This will prevent the hot engine exhaust gas from browning the grass. Many communities no longer haul grass clippings to landfills. Composting the clippings from your grasscatcher is a viable solution. For this you will have to empty the grasscatcher at the designated composting site.
- Your rider mower is equipped with a mulching plug to mulch the grass and recycle into the lawn instead of collecting in the grasscatcher bag.
- Mulch only when the grass is dry. Mulching wet grass may damage the underside of the deck because wet grass tends to stick to it. Clean deck thoroughly if you mulch wet grass.
- For effective mulching, overlap mowing paths so that the clippings are distributed evenly.

## SERVICE & ADJUSTMENTS



**WARNING:** Do not at any time make any adjustment to riding mower without first **stopping engine and disconnecting spark plug wire.**

### Brake Pedal Adjustment

During normal operation of the rider mower, the brake is subject to wear and tear. Check the brake periodically by carrying out the following test:

- Release the parking brake and place the rider mower in neutral. Depress the brake pedal and try to roll the rider mower. The tractor should not move. If the tractor moves, adjust the brake.



**WARNING:** Do not adjust the brake **while the engine is running.** Be sure to **block the wheels** of the rider mower before making any adjustments on the brake cable.

Adjustment to the brake pedal is made at the cable end. See Figure 18.

- Set the parking brake and turn ignition key off.
- Shift the cutting height lever to the lowest position.
- Pivot the cover up and remove the grasscatcher bag and the side-discharge chute or the mulching plug from the mower.
- Disconnect wire from the spark plug.
- Locate the brake cable on the right side under the front housing.
- Using a pair of 1/2" wrenches, loosen the jam nuts and back the cable out to tighten or thread inward to loosen.
- Retighten the jam nuts when proper tension is reached.
- Unlock the parking brake and repeat the test described above. Readjust if necessary.

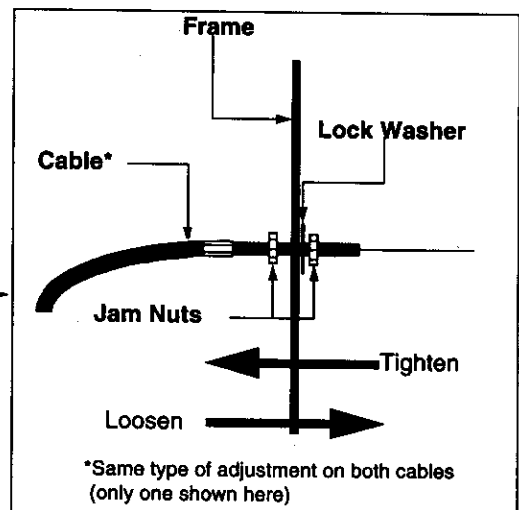
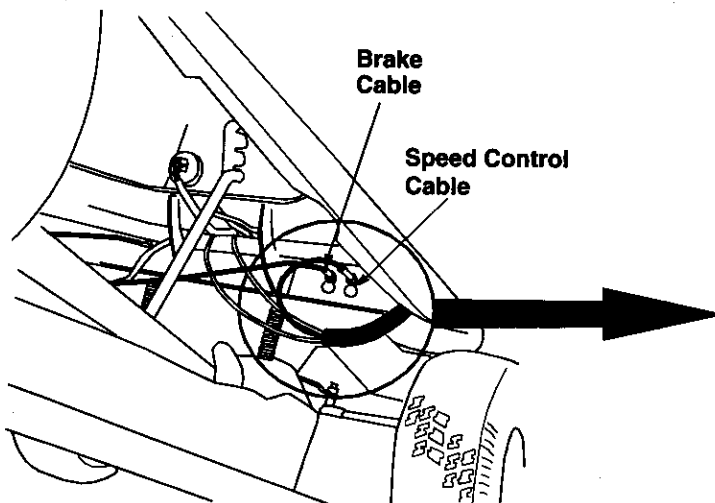

Figure 18



## Speed Control Pedal Adjustment

Adjustment to the speed control pedal is made at the cable end. See Figure 18.

- Set the parking brake and turn ignition key off.
- Shift the cutting height lever to the lowest position.
- Pivot the cover up and remove the grasscatcher bag and the side-discharge chute or the mulching plug from the mower.
- Disconnect wire from the spark plug.
- Locate the speed control cable under the front housing.
- Loosen the jam nuts and back the cable out to tighten or thread inward to loosen.
- Retighten the jam nuts when proper tension is reached.
- Reconnect the spark plug wire and pivot the cover down.

## Seat Adjustment

The seat position on the rider mower can be adjusted to maximize the operator's convenience.

- Stop the mower completely and engage the parking brake. Turn ignition off.
- Pivot the cover up.
- Loosen the four self-tapping screws on the bottom of the seat.
- Slide the seat forward or backward in the slot, and position it as desired.
- Retighten the four screws.

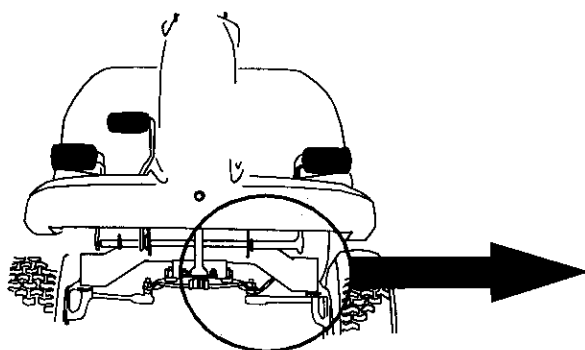

## Wheel Alignment

The front wheels should toe-in 1/16-5/16 inch. To adjust toe-in, follow these steps:

- Remove the 3/8" hex nut which holds the ball joint to the steering segment. See Figure 19.
- Adjust the ball joint in or out until the wheels toe-in approximately 1/16-5/16" (Dimension "B" should be approximately 1/16-5/16" less than dimension "A"). See Figure 19.
- Replace the ball joint into the steering segment, and replace the 3/8" hex nut.

## Blade Brake/PTO Adjustment

The blade engagement pedal should be adjusted so that if you depress it about 3/4" from the front of the slot, it should start engaging the deck belt. The PTO (power take off) switch is located in the blade brake slot on the left side of the upper frame. See Figure 20. The brake engagement pedal needs to make contact with the PTO switch for the engine to start.

Under normal operation, the blade engagement pedal should not require frequent adjustment. However, perform the following test periodically and make sure that it is in fine working condition.

- Pivot the cover up and check if there is enough slack on the deck engagement cable.
- Depress the blade engagement pedal (about 3/4 inch) and check if the belt is engaging.
- If the cable is tight or too loose or the belt is not engaging, adjust the deck engagement cable.

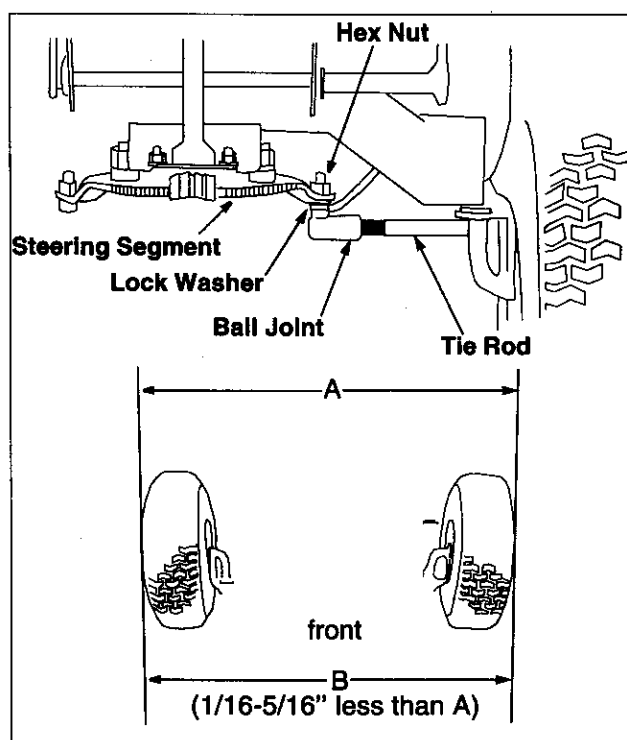
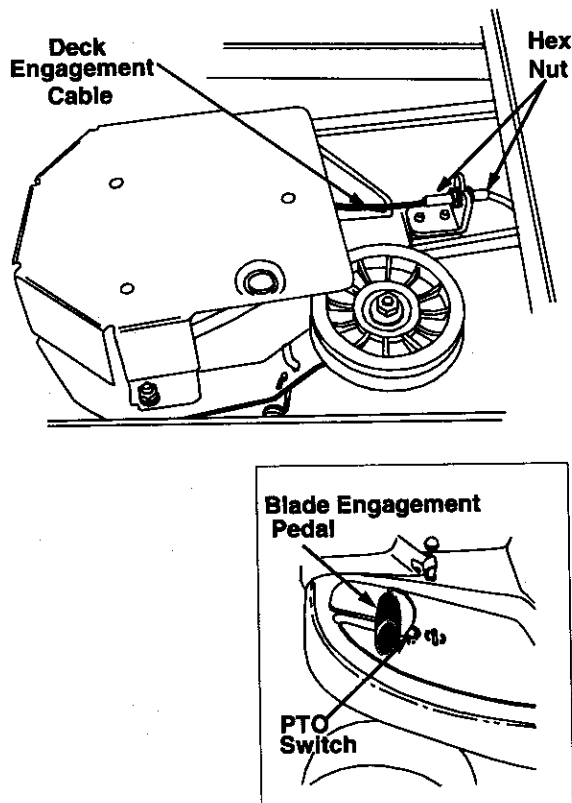

Figure 19

**NOTE:** You will have reached correct adjustment to the deck engagement cable when the cable moves approximately 1/2" off center line in both directions.

Adjustment to the blade brake will have to be made at the cable end. See Figure 20.



**Figure 20**

- If the belt is slipping when you depress the blade engagement pedal about 3/4", loosen the two hex nuts on the cable. See Figure 20.
- If the belt is engaging sooner than when the blade engagement pedal is 3/4" from the PTO switch, tighten both the hex nuts on the cable. See Figure 20.
- Repeat the blade engagement test and readjust if necessary.
- Pivot the cover back to its original position.

### Belt Replacement

There are two drive belts and one deck belt in your rider mower; follow the description below to identify the belts.

1. The lower drive belt goes from the variable speed pulley to the transmission pulley.
2. The upper drive belt goes from the variable speed pulley to the upper sheave of engine pulley.
3. The deck belt goes from the deck pulley to the lower sheave in engine pulley.

- Periodically check to see if these belts are too loose or damaged through wear and tear. If so, replace with new belt. While ordering these belts, refer to the Parts List section in this manual for the correct part number.

### Deck Belt

- Engage the parking brake and turn the ignition off. Pivot the cover up and remove the grasscatcher. Remove the spark plug wire.
- Put the deck at the lowest cutting height by adjusting the cutting height adjustment lever to the lowest position.
- Working from the rear of the mower, remove the hex nut and the lock washer on the right side of the deck belt guard. You will need a 7/16" socket wrench with 6" extension to remove this bolt.

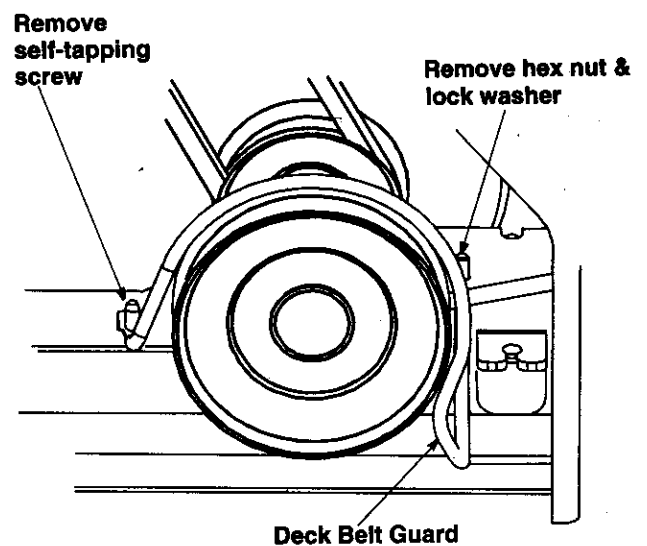

(View from underneath the mower while working from the rear)

**Figure 21**

- Using a 3/8" socket wrench, remove the self-tapping screw that holds opposite side of the deck belt guard. See Figure 21. Push the right side of the deck belt guard forward and let it drop down.
- Using a 1/2" socket wrench, remove two self-tapping screws, lock washer and hex nut that hold the deck belt cover to the deck. See Figure 22. For this, you will have to work from the top left side of the mower. Remove the belt cover.
- Using a 9/16" wrench, loosen the hex nut on the idler pulley. See Figure 22.
- Remove belt from around deck pulley, idler pulley, and the engine pulley.
- Place the new belt around the deck pulley and the engine pulley making sure that the belt is routed inside the belt keepers. There are two

belt keepers under the grasscatcher, one on the idler and the other under the deck belt cover. See Figure 22 .

- Reinstall the deck belt cover and secure with the two self-tapping screws and the lock washer and hex nut.

**NOTE:** Belt keeper "A" must be mounted on the outside of the belt.

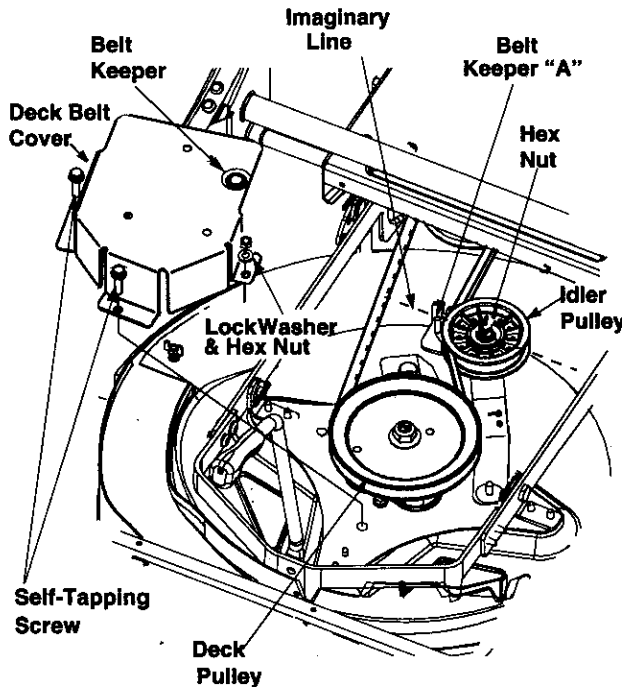

**Figure 22**

- Make sure to align the belt keeper in line with the frame. See Figure 22. **NOTE:** An imaginary line between the belt keeper and idler pulley should be parallel to frame as shown above.
- Again working from under the rear of the mower, reinstall the rear deck belt guard.
- Replace the grasscatcher and pivot the cover back.

#### Lower Variable Speed Belt

- Remove the rear deck belt guard following first five steps for deck belt removal on page 17. Remove belt from the engine pulley.
- Push the spring loaded idler, located on the left side of the transmission, to the right. Remove belt from around the idler and then the transmission pulley. See Figure 23.
- Using a 9/16" socket, remove bolt, spacer and the flat washer from the variable speed pulley. See Figure 23. Drop the pulley down and remove the belt.
- Replace new belt and reassemble following above instructions in reverse order.
- Make sure that the belt is **routed inside of belt keeper**, and the belt keeper is reassembled in

the same location from where it was removed.

#### Upper Variable Speed Belt

- Remove the engine pulley using a 9/16" socket wrench with a 6" extension. The engine pulley is located in front of the transmission.
- Drop the engine pulley down and remove the belt from around it.
- Push the idler bracket to the right and remove the belt. See Figure 23.
- Replace belt and reassemble in reverse order.

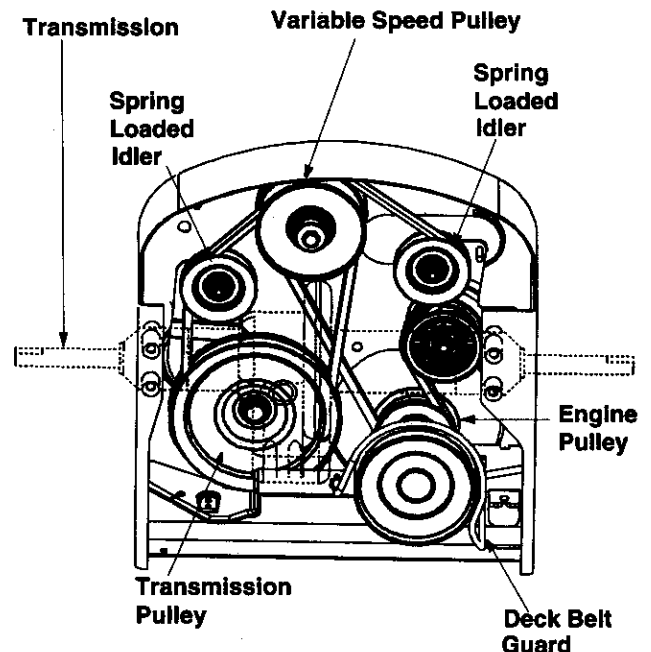

View from underneath the mower while working from the rear

**Figure 23**

#### Fuse Replacement

The fuse is located next to the spark plug under the rear frame. Fuses seldom fail without a reason. If the fuse blows, the source problem must be corrected or the new fuse will blow again.

Check for loose connections in the fuse holder and replace holder if necessary. A dead short may be in the cranking or charging circuit where insulation may have rubbed through and exposed the bare wire. Replace the wire or repair with electrician's tape if the wire strands have not been damaged. Also look for a wire pinched between body panels, burned by the exhaust pipe or muffler, or rubbed against a moving part.

- Stop the rider mower and engage the parking brake. Remove the ignition key.
- Pivot the cover up. Disconnect the spark plug wire and ground it.
- Pull the fuse out of the lead wire.
- Replace with new automotive fuse.
- Make sure to reconnect the spark plug wire before pivoting the cover back.

## Adjusting the Deck

**IMPORTANT:** Please note that the valve stems on the front wheels of this rider mower are on the inside of the wheels.

The front of the deck should be approximately 1/4" to 3/8" lower than the rear of the deck. To maintain that, you may have to adjust the deck pitch. In the case of uneven cut, you will have to level the deck. For both adjustments, follow the steps below:

**NOTE:** Check pressure of all four tires before levelling the deck. Recommended tire pressure is 12 p.s.i.

- Place the deck in the engaged position.
- Loosen the top hex nut out of the three nuts that hold the hex bolt and the ferrule on the deck hanger link assembly. See Figure 24. **Do not try to loosen or tighten the bottom nut.**
- Loosen the second nut up or down as necessary. See Figure 24.
- When desired adjustment is reached, retighten the two nuts.
- Adjust both sides if necessary.

## Cleaning Engine

- Promptly wipe off any fuel or oil spilled on the machine with clean cloth.
- Clean the underside of the blade housing after each mowing. Do not let clippings or debris accumulate around the blade which may cause rust on the deck.
- Using a brush or cloth, remove grass, chaff or debris from the finger guard on the engine daily to prevent overheating of the engine. Do not clean with a forceful spray of water since water contaminates the fuel system.
- Keep the governor linkage, springs and controls free of debris.
- If engine muffler is equipped with spark arrester screen, remove and clean the screen regularly. Replace if damaged or plugged with debris. Clean muffler area and remove any grass or other debris before operating the unit.

## Throttle/Choke Control Adjustment

Refer to separate engine manual.

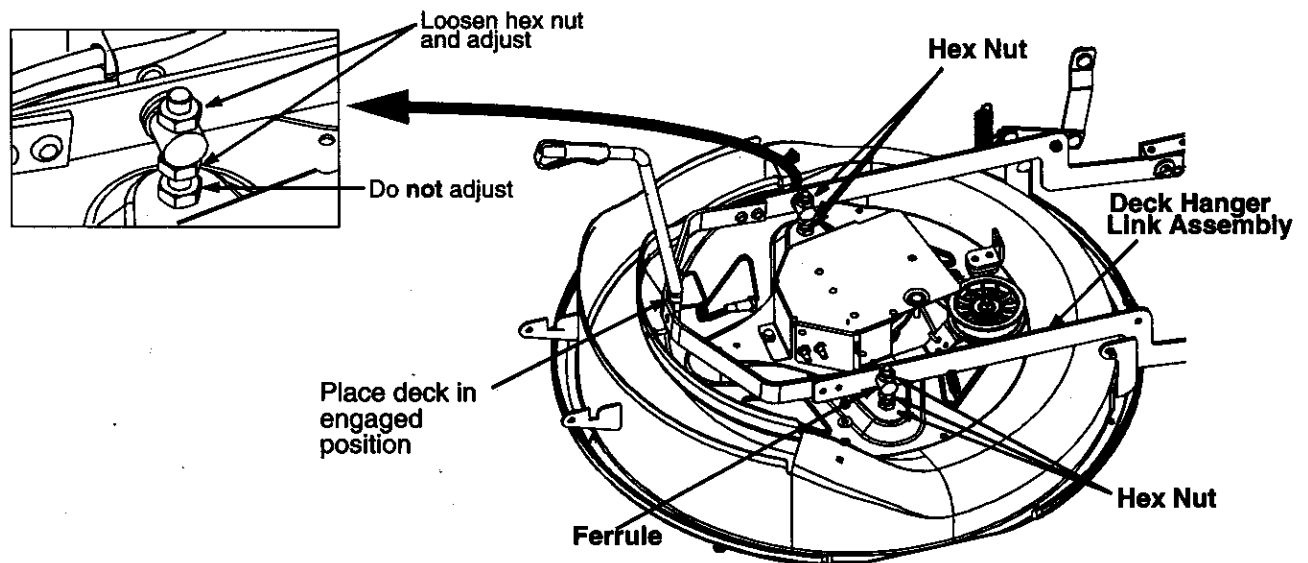

Figure 24

# MAINTENANCE

## General Recommendations

- Always observe safety rules when performing any maintenance.
- The warranty on this rider mower does not cover items that have been subjected to operator abuse or negligence. To receive full value from the warranty, operator must maintain the rider mower as instructed in this manual.
- Changing of engine governed speed will void engine warranty.
- Some adjustments will have to be made periodically to maintain your unit properly.
- Periodically check all fasteners and make sure these are tight.



**WARNING:** Always stop the engine and disconnect the spark plug wire before performing any maintenance or adjustments.

## Cutting Blade

### Removal



**WARNING:** Protect your hands by wearing heavy gloves or using a rag to grasp the cutting blade.

- Remove the 5/8" hex flange nut which holds the blade to the blade spindle.
- Remove blade from the spindle. See Figure 25.

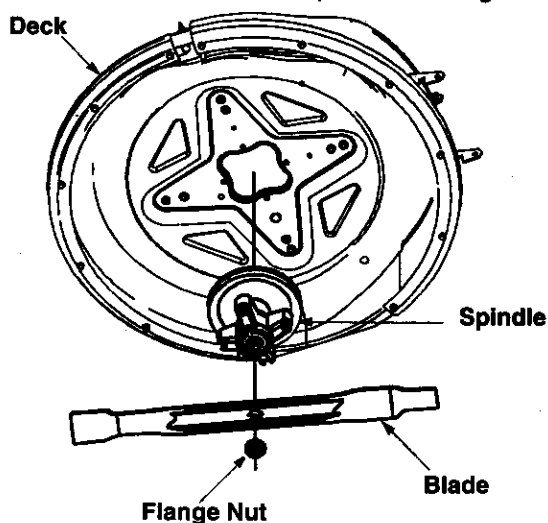

Figure 25

### Sharpening

- When sharpening the blade, follow the original angle of grind as a guide. It is **extremely important** that each cutting edge receives an equal amount of grinding to prevent an unbalanced blade. An unbalanced blade will cause excessive vibration when rotating at high speeds, may cause damage to the mower and could break causing personal injury.
- The blade can be tested for balance by

balancing it on a round shaft screwdriver. Remove metal from the heavy side until it balances evenly.

### Reassembly

- Before reassembling the blade to the unit, lubricate the spindle with light oil (or engine oil).
- Be sure to properly align "star" fitting on blade with "star" on spindle.
- When replacing the blade, be sure to install the blade with the side of the blade marked "Bottom" (or with part number) facing the ground when the mower is in the operating position.
- Blade Mounting Torque: 70/90 foot-pounds maximum.

**NOTE:** To ensure safe operation, all nuts and bolts must be checked periodically for correct tightness.

## Oil Drain Sleeve

Your rider mower has a plastic oil drain sleeve packed with the loose parts for your convenience in draining oil from the crankcase.

- To drain the oil, snap small end of the oil drain sleeve onto oil sump. See Figure 26.
- Remove drain plug and drain oil into a suitable container.

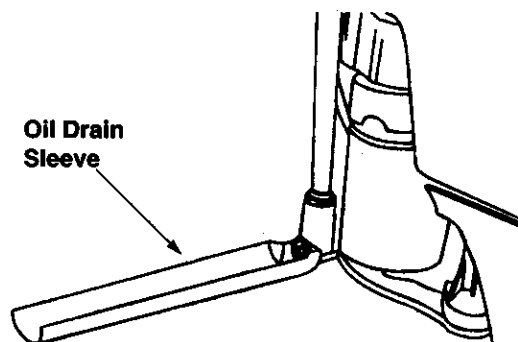

Figure 26

## ENGINE

Refer to the separate engine manual for engine maintenance instructions.

- Maintain engine oil as instructed in the separate engine manual packed with your unit. Read and follow instructions carefully.
- Poor engine performance and flooding usually indicates that the air cleaner should be serviced. Service air cleaner as per the engine manual. Clean frequently under extremely dusty conditions.
- The spark plug should be cleaned and the gap reset once a season. Spark plug replacement is recommended at the start of each mowing

season. Check engine manual for correct plug type and gap specifications.

**NOTE:** Your engine is equipped with a resistor spark plug, When replacing plug, make sure to use resistor type.

### Fuel Filter

Your unit is equipped with a replaceable in-line fuel filter. Replace filter whenever contamination or discoloration is noticed. Order replacement filter through your engine authorized service dealer.

### Lubrication (Refer to Figure 27)

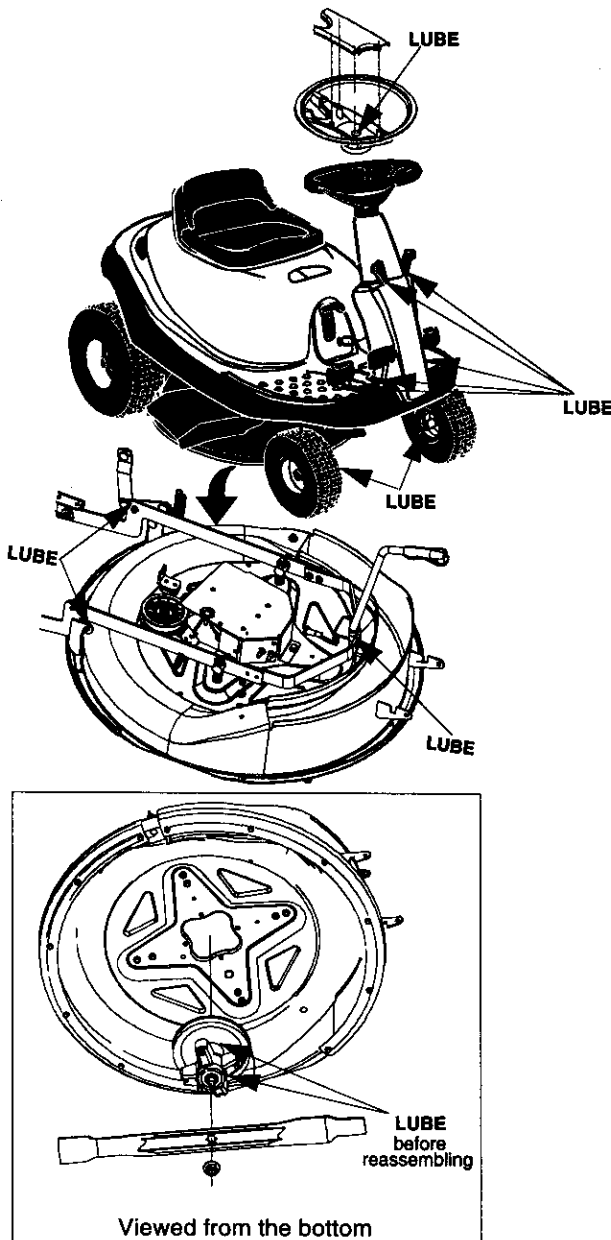

Figure 27: Lubrication Chart

### Blade Assembly

- Lubricate blade assembly and deck spindle only while reassembling the blade either after sharpening or replacement.

### Pivot Points

- Lubricate all pivot points with light oil at least once a season.

### Steering Shaft and Gear

- Lubricate steering shaft and spline at least once a season with light oil.
- Lubricate teeth of the external steering gears with automotive multi-purpose grease every 25 hours of operation or once a season.

### Linkage

- Lubricate all deck linkage and height adjustment linkage with a light oil.

### Front Wheels

- Lubricate at least once a season with automotive multi-purpose grease.

### Engine

- Maintain the engine as recommended in the separate engine manual.

### Battery Care

**NOTE:** If your rider mower was shipped with a wet battery which is maintenance-free, skip the battery care instructions.

### Check fluid level

- Check electrolyte level once a month. If the level falls lower than middle of upper level, add distilled water to restore level. **Never add acid to raise the electrolyte level.**
- After adding water, charge the battery to mix water and electrolyte.
- Always keep the battery clean.
- Apply grease around terminals to prevent corrosion.

**NOTE:** After operating the rider mower for a long period of time, check the fluid level in the battery as it can overheat and lose fluid.

### Battery Recharging

Recharging is necessary if the battery sits unused for longer than one month. Charge battery with a current of 1 to 1.5 amps.



**WARNING:** When removing or installing the battery, follow these instructions to prevent the screwdriver from shorting against the frame.

### Removing the Battery:

- Disconnect the negative cable first, then the positive cable.

### Installing the Battery:

- Place the battery in its assigned position. For location and set-up, refer to Figure 4.
- Connect the positive cable first, then the negative cable.

### Jump Starting:

- First, connect end of one jumper cable to the positive terminal of the good battery, then the other end to the positive terminal of the dead battery.
- Connect the other jumper cable to the negative terminal of the good battery, then to the frame of the unit with the dead battery.



**WARNING:** Failure to use this procedure could cause sparking, and the gas in either battery could explode.

### Cleaning the battery

- Clean the battery by removing it from the unit and washing with baking soda and water

solution. If necessary, scrape the battery terminals with a wire brush to remove deposits. Coat terminals and exposed wiring with grease or petroleum jelly to prevent corrosion.

### Battery Failures

Some common causes for battery failure are: incorrect initial activation, lack of water, adding chemicals other than water after initial activation, undercharging, overcharging, freezing, corroded connections etc. These failures do not constitute warranty.

### Tires

- Recommended operating tire pressure is approximately 12 p.s.i. Maximum tire pressure under any circumstance is 30 p.s.i. Equal tire pressure should be maintained on all tires.
- When installing a tire to the rim, be certain rim is clean and free of rust. Lubricate both the tire and the rim generously. Never inflate to over 30 p.s.i. to seat beads.



**WARNING:** Excessive pressure (over 30 p.s.i.) when seating beads may cause tire/rim assembly to burst with force sufficient to cause serious injury.

## OFF-SEASON STORAGE

If the machine is to be inoperative for a period longer than 30 days, prepare for storage as follows.

### Rider Mower

- Clean the engine and the entire unit thoroughly.
- Lubricate all pivot points. Wipe the entire machine with an oiled rag to protect the surfaces.
- Store unit in a clean, dry area. Do not store next to corrosive materials, such as fertilizer.
- When storing any type of power equipment in an unventilated or metal storage shed, care should be taken to rustproof the equipment. Using a light oil or silicone, coat the equipment, especially any chains, springs, bearings and cables.

### Battery

- Charge battery fully. The battery loses some of its charge each day when the unit is not used. NEVER store battery without a full charge. Recharge battery before returning to service or every two months, whichever occurs first.
- When storing unit for extended periods, disconnect battery cables and remove the battery from the unit.
- Clean dirt and chaff from cylinder, cylinder head fins, blower housing, rotating screen and muffler area.

### Engine

- Refer to the engine manual for storage instructions. Make sure to store the engine properly so that your equipment can work smoothly afterwards.

# TROUBLE SHOOTING

## General Problems

Trouble	Possible Cause	Remedial Action
Excessive vibration	<ol style="list-style-type: none"> <li>1. Bent or damaged blade</li> <li>2. Bent blade.</li> </ol>	<ol style="list-style-type: none"> <li>1. Stop engine immediately. Check all pulleys, blade adapters, keys and bolts for tightness and spindle damage. Tighten or replace any damaged parts.</li> <li>2. Stop engine immediately. Replace damaged blade. Only use original equipment blades.</li> </ol>
Mower will not discharge grass or leaves uncut strips	<ol style="list-style-type: none"> <li>1. Engine speed low.</li> <li>2. Speed selection.</li> <li>3. Cutting height set too low.</li> <li>4. Blades short or dull.</li> </ol>	<ol style="list-style-type: none"> <li>1. Throttle must be set at full throttle.</li> <li>2. Use lower ground speed. Slower the ground speed, better the quality of cut.</li> <li>3. Raise the deck.</li> <li>4. Sharpen or replace blades (uncut strip problem only).</li> </ol>

## Belt Problems

Trouble	Possible Cause	Remedial Action
Broken Belt	<ol style="list-style-type: none"> <li>1. Sudden stop or shock load to belt</li> <li>2. Incorrect belt used</li> <li>3. Belt engaged abruptly</li> <li>4. Defective or damaged belt</li> </ol>	<ol style="list-style-type: none"> <li>1. Inspect rider for cause such as foreign objects stuck in between deck and frame or belt path. Remove obstruction and check * for damage. Replace belt if needed.</li> <li>2. Replace* with proper belt. Check Parts list in this manual for correct part number.</li> <li>3. Engage belt slowly by depressing the blade engagement pedal slowly.</li> <li>4. Replace* with proper belt. Follow instructions in Service and Adjustments section.</li> </ol>
Belt comes off	<ol style="list-style-type: none"> <li>1. Belt too loose; stretched</li> <li>2. Broken or weak idler spring</li> </ol>	<ol style="list-style-type: none"> <li>1. Readjust belt. Replace if needed. Follow instructions for belt replacement in the Service and Adjustments section.</li> <li>2. Replace. Order with correct part number from Parts List in this manual.</li> </ol>
Belt shreds	<ol style="list-style-type: none"> <li>1. Belt guides or guards incorrectly adjusted</li> <li>2. Pulleys not aligned</li> <li>3. Pulley rusted or in otherwise bad condition; frozen bearing</li> </ol>	<ol style="list-style-type: none"> <li>1. Adjust belt guides and guards so that these are approximately 1/16 to 1/8 inch from belt when engaged.</li> <li>2. Realign pulleys to be within approximately 1/16 inch of each other. Check with straight edge. Make sure fastening hardware is tight.</li> <li>3. Replace pulleys. Order with correct part number from the Parts List in this manual. Adjust new pulleys to 1/16 inch.</li> </ol>

\*Do not use a screwdriver to push or pry belt on to pulley. This may damage internal cords.



## Engine Problems

Trouble	Possible Cause	Remedial Action
Engine will not crank	<ol style="list-style-type: none"> <li>1. Safety switch button not depressed</li> <li>2. Battery installed incorrectly</li> <li>3. Battery dead or weak.</li> <li>4. Blown fuse or circuit breaker</li> <li>5. Engine ground wire loose.</li> </ol>	<ol style="list-style-type: none"> <li>1. There are two switches in the starting circuit of your unit. Make sure that the actuator is fully depressing both switch buttons. Brake pedal must be depressed and blade engagement pedal disengaged.</li> <li>2. Install the battery with negative terminal attached to the black ground wire. Attach the positive terminal to the red wire which goes to the solenoid. Charge the battery fully before installation.</li> <li>3. Check fluid level in battery. If fluid level is low, fill to just below split rings with water. Charge with 6 AMP charger until fully charged. If this does not work, replace battery.</li> <li>4. Replace fuse following instructions on page 19.</li> <li>5. Make sure the black ground wire runs from engine to frame or mounting bolt.</li> </ol>
Engine cranks but will not start	<ol style="list-style-type: none"> <li>1. Throttle/choke not in starting position.</li> <li>2. No fuel to the carburetor</li> <li>3. Fuel line or in-line fuel filter plugged</li> <li>4. No spark to spark plug</li> <li>5. Faulty spark plug</li> <li>6. Dirty air cleaner</li> </ol>	<ol style="list-style-type: none"> <li>1. Check owner's guide for correct position for throttle control/choke for starting.</li> <li>2. Gasoline tank empty. Fill with gasoline.</li> <li>3. Remove and clean fuel line. Replace filter if necessary.</li> <li>4. Spark plug lead disconnected. Connect lead. Hold spark plug lead away from engine block about 1/8". Crank engine. There should be a spark. If not, have engine repaired at authorized engine service dealer.</li> <li>5. To test, remove spark plug. Attach spark plug lead to spark plug. Ground the spark plug body against the engine block. Crank the engine. The spark plug should fire at the electrode. Replace if it does not.</li> <li>6. If the air cleaner is dirty, the engine may not start. Clean or replace as recommended by the engine manufacturer.</li> </ol>
Engine smokes	<ol style="list-style-type: none"> <li>1. Engine oil has been overfilled</li> <li>2. Dipstick not seated or broken</li> <li>3. Engine loses crankcase vacuum</li> </ol>	<ol style="list-style-type: none"> <li>1. Check oil level.</li> <li>2. Replace defective part.</li> <li>3. Engine breather defective. Replace.</li> </ol>

**NOTE:** For problems beyond those listed here, please contact the local authorized service dealer or call the Customer Support Service line listed on page 2 of this manual.

# PARTS LIST

## Steering Wheel

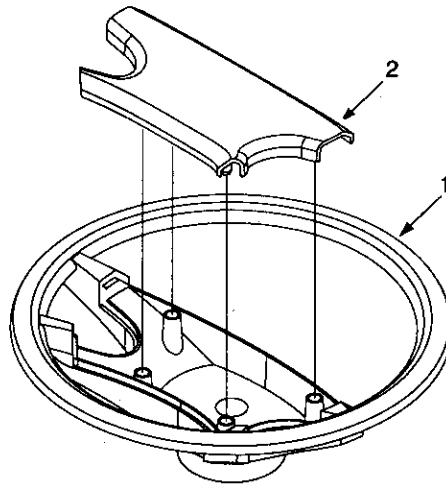

Ref. No.	Part No.	Code	Description
1	731-1869		Steering Wheel: 4 Spoke
2	731-1904		Steering Wheel Cap

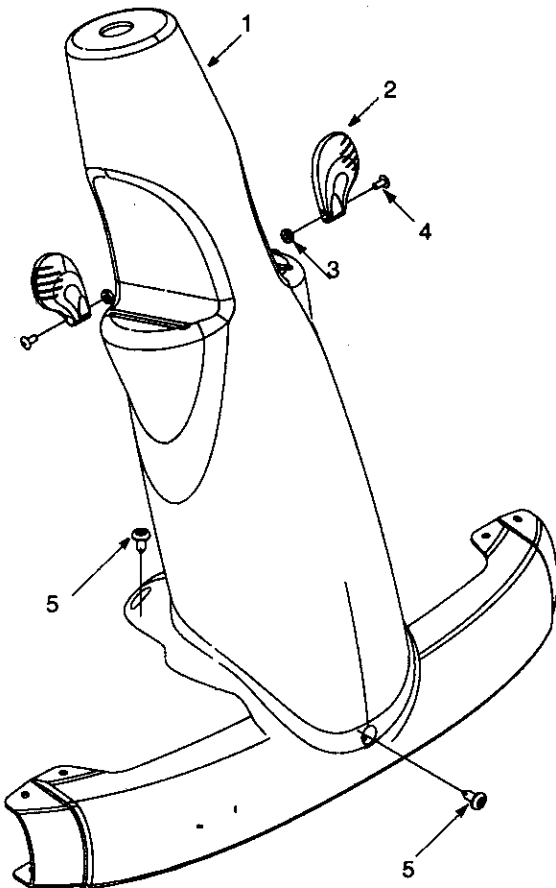

Ref. No.	Part No.	Code	Description
1	731-1877		Steering Column: Green
2	731-1918		Control Knob: Yellow
3	712-0142		Hex Nut 8-32
4	710-3217		Pan Head Machine Screw #8-32
5	710-0599		Hex Screw TT 1/4-20 x .50"

**NOTE:** For painted parts, please refer to the list of color codes below. Please add the applicable color code, wherever needed, to the part number to order a replacement part. For instance, if a part numbered 700-xxxx is painted Oyster Gray, the part number to order would be 700-xxxx-062.

Yard-Man Green: 0665  
 Yard-Man Yellow: 0674  
 Powder Black: 0637

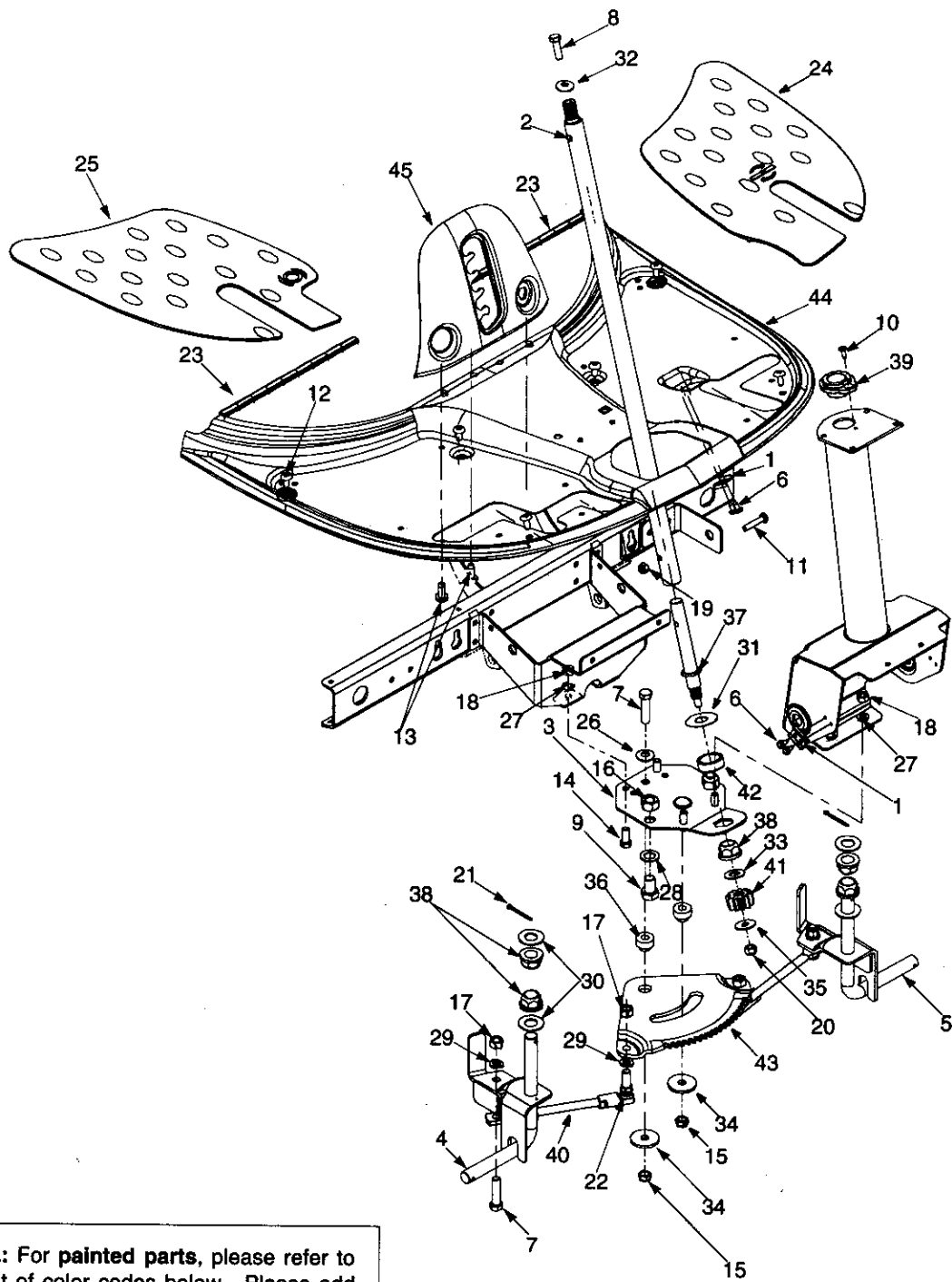

**NOTE:** For painted parts, please refer to the list of color codes below. Please add the applicable color code, wherever needed, to the part number to order a replacement part. For instance, if a part numbered 700-xxxx is painted Oyster Gray, the part number to order would be 700-xxxx-062.

Yard-Man Green: 0665

Yard-Man Yellow: 0674

Powder Black: 0637

Ref. No.	Part No.	Code	Description	Ref. No.	Part No.	Code	Description
1	17962		Switch Plate	22	723-0156		Ball Joint
2	650-0007		Steering Tube Assembly	23	731-0511		Trim Strip
3	683-0033A		Steering Support Bracket	24	735-0265		Floor Pad: LH
4	683-0178A		Front Axle Assembly: RH	25	735-0266		Floor Pad: RH
5	683-0179A		Front Axle Assembly: LH	26	736-0105		Bell Washer
6	710-0224		Hex Screw AB	27	736-0119		Lock Washer
7	710-0459A		Hex Screw 3/8-24 x 1.5" Gr.5 Special	28	736-0160		Flat Washer
8	710-0643		Lock Screw 5/16-18 x 1.0" Gr.5	29	736-0169		Lock Washer
9	710-0689		Hex Screw 1/2-13 x 0.75"	30	736-0187		Flat Washer
10	710-0837		Oval Csunk Screw #10-16 x 0.625"	31	736-0196		Flat Washer
11	710-0958		Hex Screw 1/4-20 x 1.25 Gr.5 Special	32	736-0242		Belleville Washer
12	710-1017		AB Screw 1/4-14 x 0.625"	33	736-0272		Flat Washer
13	710-1611		Self-Tapping Screw 5/16-18 x 0.75"	34	736-0320		Flat Washer
14	710-3008		Hex Screw 5/16-18 x 0.75"	35	736-3078		Flat Washer
15	712-0116		Lock Nut 3/8-24	36	738-0541		Spacer
16	712-0206		Hex Nut 1/2-13	37	738-3089A		Steering Adapter
17	712-0241		Hex Nut	38	741-0225		Hex Flange Bearing
18	712-0267		Hex Nut	39	741-0356		Bearing: Steering Column
19	712-0324		Lock Nut 1/4-20	40	747-0955		Tie Rod
20	712-0411		Lock Nut	41	748-0290		Pinion Gear
21	714-0470		Cotter Pin	42	750-0532		Spacer
				43	783-0411		Gear: Steering Segment
				44	783-0565A		Upper Frame Cover
				45	783-0566A		Lift Plate

# Operation Control

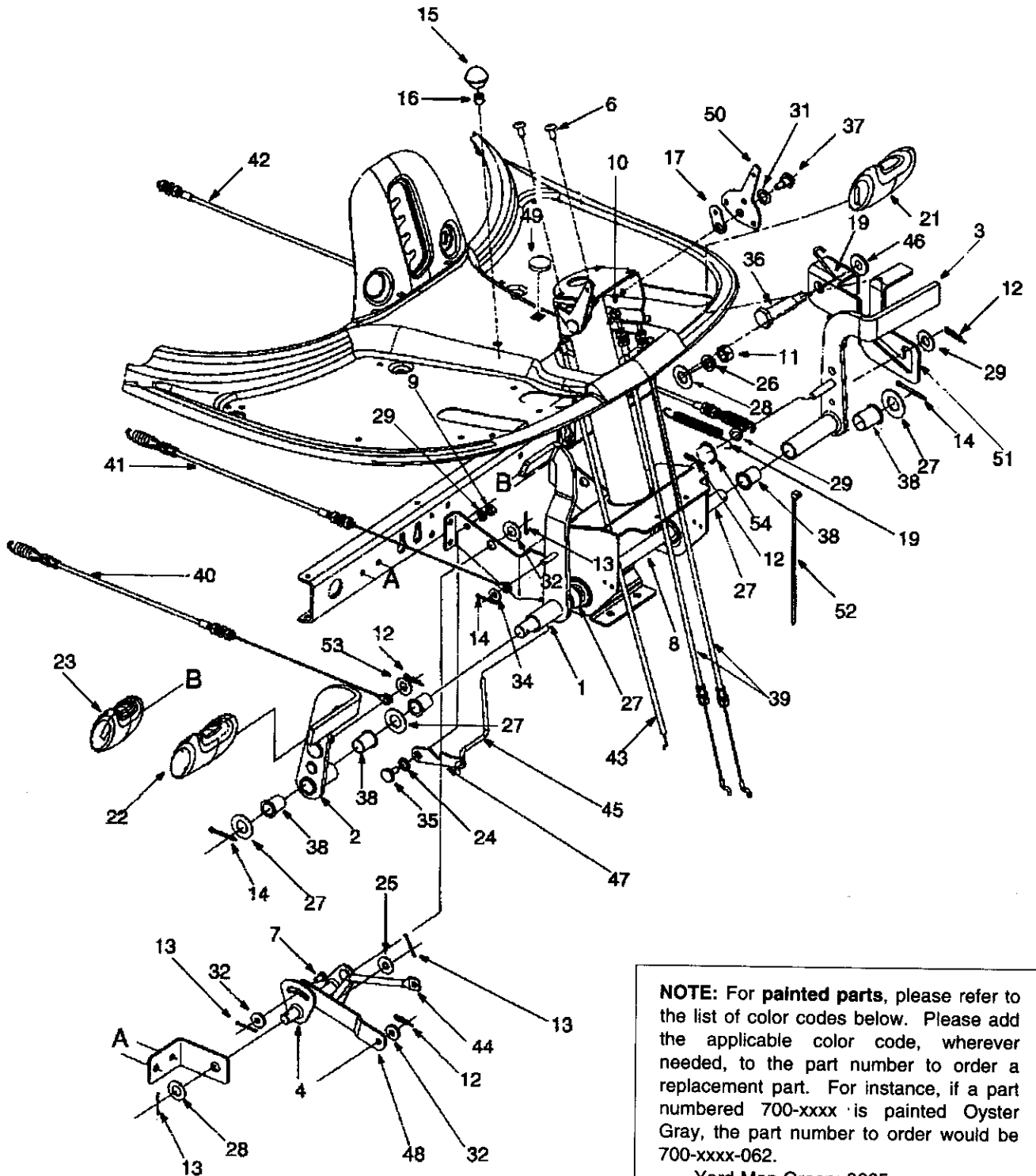

**NOTE:** For **paint**ed parts, please refer to the list of color codes below. Please add the applicable color code, wherever needed, to the part number to order a replacement part. For instance, if a part numbered 700-xxxx is painted Oyster Gray, the part number to order would be 700-xxxx-062.

Yard-Man Green: 0665  
 Yard-Man Yellow: 0674  
 Powder Black: 0637

Ref. No.	Part No.		Description	Ref. No.	Part No.		Description
1	683-0155		Brake Pedal Assembly	30	736-0329		Lock Washer
2	683-0156		Variable Pedal Assembly	31	736-0608		Spring Washer
3	683-0275	N	Deck Pedal Assembly	32	736-3000		Flat Washer
4	683-0161		Shift Cam Assembly	33	736-3019		Flat Washer .531 X 1.062 X .134
6	710-1017		Ab Screw 1/4-14 X .625	34	736-3020		Flat Washer .271 X .630 X .065
7	711-0701		Clevis Pin	35	738-0255		Shoulder Screw .375 Dia X .18
8	711-1156		Shaft	36	738-0373		Shoulder Screw
9	712-0287		Hex Nut 1/4-20	37	738-0974		Shoulder Screw .375 X .380 X 1/4-20
10	712-0324		Lock Nut 1/4-20				
11	712-3017		Hex Nut 3/8-16	38	741-0591		Flange Bearing
12	714-0104		Internal Cotter Pin	39	746-0935A		Shift Cable
13	714-0111		Hairpin Clip	40	746-0936		Variable Drive Cable
14	714-0470		Hairpin Clip	41	746-0937		Brake Cable
15	720-0166		Ball Knob	42	746-0940		Deck Cable
16	731-0405		Snap-on Bushing	43	746-0964		Throttle Choke Cable: 67"
17	731-1913		Stop Lever	44	747-0963		Brake Rod
19	732-0865		Torsion Spring	45	747-0964		Brake Lock Out Rod
20	732-0815		Extension Spring	46	750-0736		Shoulder Spacer
21	735-0262		Deck Pad	47	783-0473		Brake Lock Out Bracket
22	735-0261		Drive Pad	48	783-0525		Self-Propelled Pedal Link
23	735-0263		Brake Pad	49	726-0450		Plug Cap
24	736-0117		Flat Washer 3/8 X .620 X .033	50	783-0593A		Shift Lever
25	736-0159		5/16 Washer	51	783-0794	N	Bracket: Lock-out Pedal
26	736-0169		Lock Washer	52	726-0157		Cable Tie
27	736-0187		Flat Washer	53	736-0300		Flat Washer .406 I.D. x .875 O.D.
28	736-0272		Flat Washer .510 X 1.00 X .060				
29	736-0133		Flat Washer .406 x 1.25 x .10	54	726-0100		Push Cap

# Deck Hanger Link

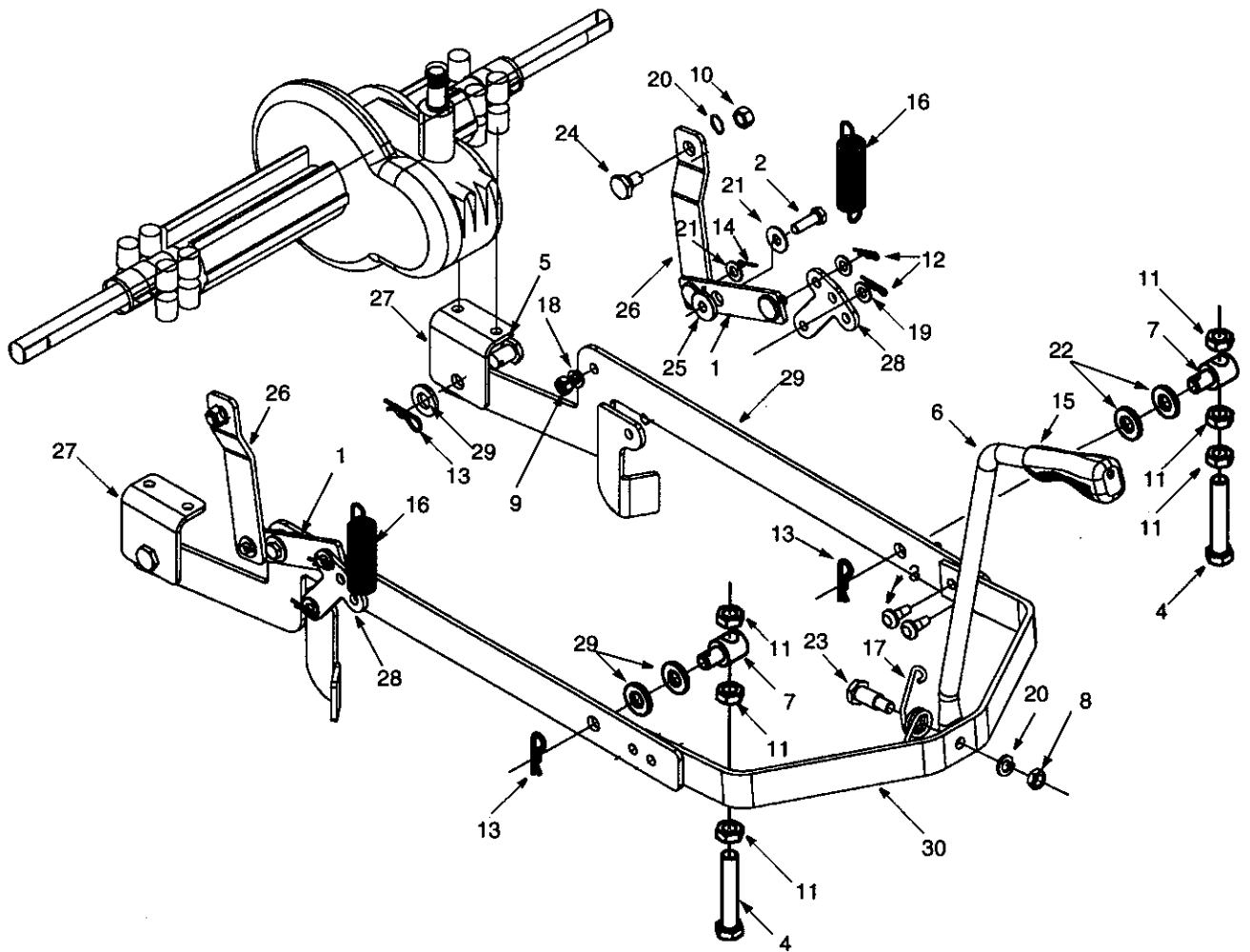

Ref. No.	Part No.	Code	Description	Ref. No.	Part No.	Code	Description
1	683-0152		Pivot Link Assembly	16	732-0829		Extension Spring
2	710-0376		Hex Screw 5/16-18 X 1.00 Gr.5	17	732-0837		Torsion Spring
4	710-3230		Hex Bolt 1/2-13 X 2.75 Gr.5 Special	18	736-0119		Lock Washer 5/16
5	711-0332		Lift Bracket Pin	19	736-0140	N	Flat Washer .385 I.D. x .620 O.D.
6	711-1120		Lift Rod	20	736-0169		Lock Washer
7	711-3319		Ferrule	21	736-0275		Flat Washer 5/16
8	712-3008		Jam Nut 3/8-16 Gr. 5	23	738-0145		Shoulder Screw
9	712-3010		Hex Nut 5/16-18	24	738-0183		Shoulder Screw
10	712-0266		Hex Cent. Lock Nut 3/8-16	25	738-0958		Shoulder Spacer
11	712-3048		Hex Jam Nut 1/2-13 Gr.5	26	783-0435		Upper Deck Link
12	714-0104		Cotter Pin	27	783-0437		Axle Bracket: Rear
13	714-0147		Cotter Pin	28	783-0440		Lower Link
14	714-3010		Cotter Pin	29	736-0257	N	Flat Washer .526 I.D. x 1.262 O.D.
15	720-0298		Handle Grip	30	683-0194		Crossbar Lift Link

# Transaxle Assembly

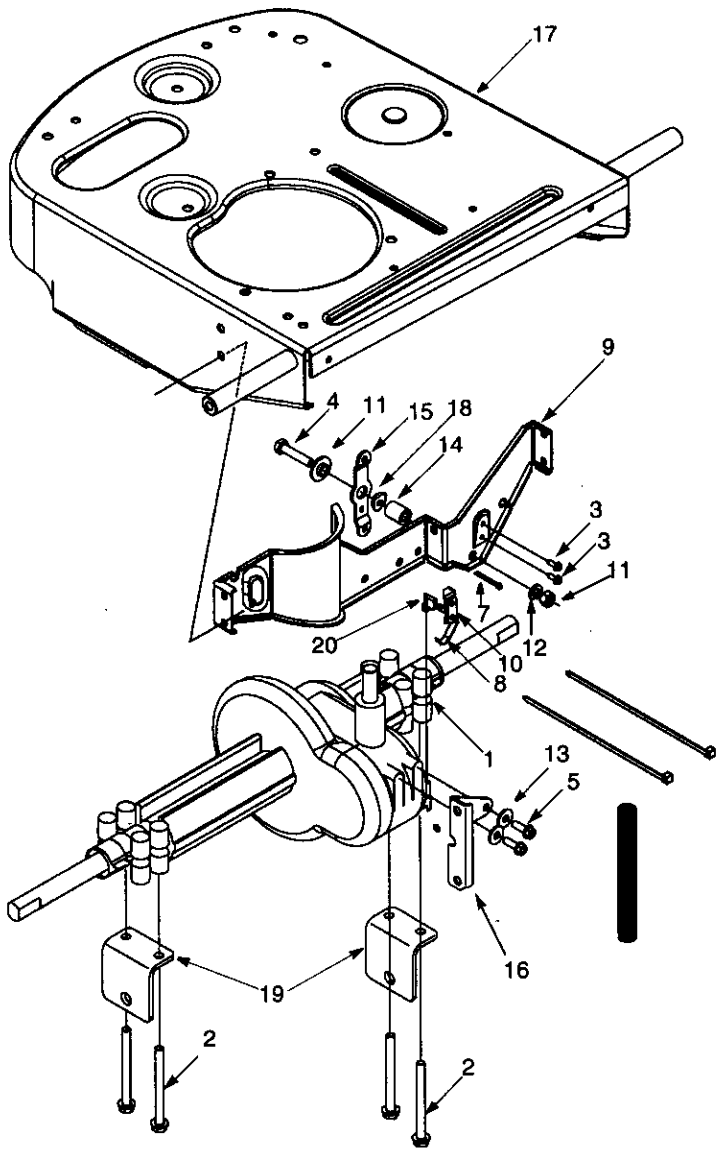

Ref. No.	Part No.	Code	Description
1	629-0865		Harness Assembly Adapter
2	710-1208		Hex TT Screw 5/16-18 x 3.50
3	710-0227		Hex Washer Head Self-Tap.Screw
4	710-0805		Hex Screw 5/16-18 x 1.5 Gr. 5
5	710-0642		Thd. Forming Scr. 1/4-20x .75
6	712-3010		Hex Nut 5/16-18
7	714-0115		Cotter Pin
8	726-0320		Insulator Nut Plate
9	783-0809	N	Transaxle Support Bracket
10	725-1713A		Spring Switch
11	736-0289		Shoulder Bushing
12	736-0119		Lock Washer 5/16
13	736-0173		Flat Washer .28 I.D. x .74 O.D. x .083
14	750-1064		Spacer
15	783-0433A		Shift Lever
16	783-0591		Transaxle Bracket
17	683-0149A		Frame Assembly
18	736-3013		Flat Washer
19	783-0437		Rear Axle Bracket
20	729-0268		Insulation Connector

**NOTE:** For painted parts, please refer to the list of color codes below. Please add the applicable color code, wherever needed, to the part number to order a replacement part. For instance, if a part numbered 700-xxxx is painted Oyster Gray, the part number to order would be 700-xxxx-062.

Yard-Man Green: 0665  
 Yard-Man Yellow: 0674  
 Powder Black: 0637



# Variable Drive:

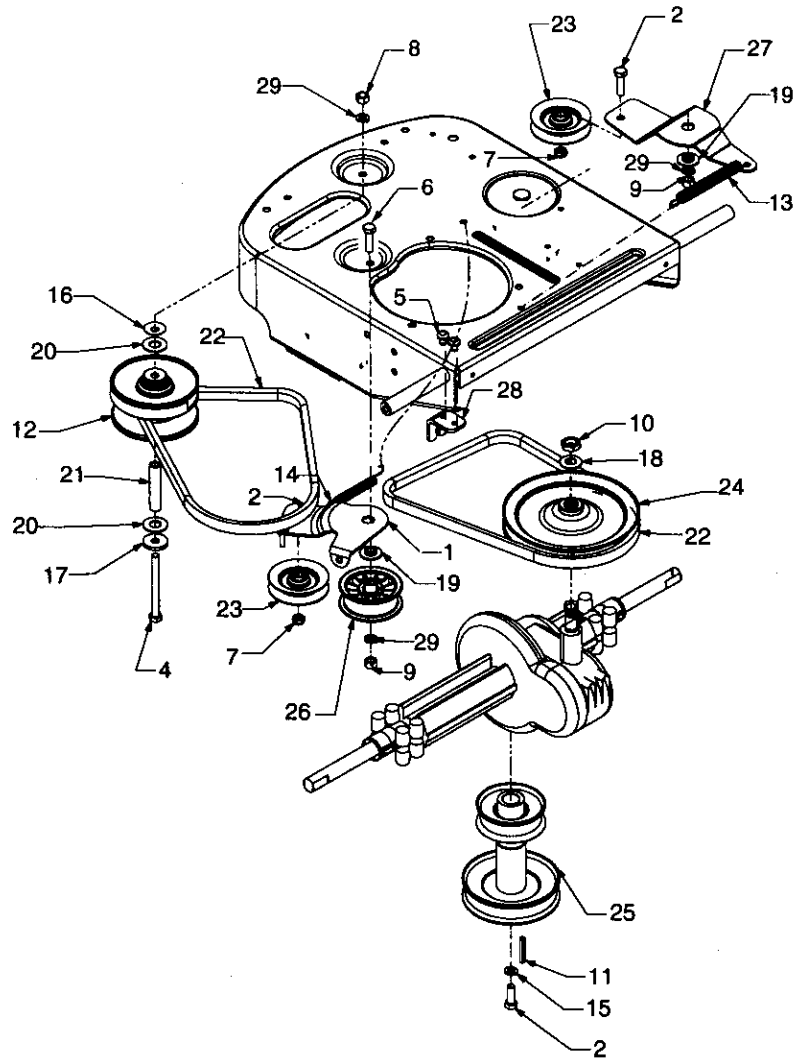

Ref. No.	Part No.	Code	Description	Ref. No.	Part No.	Code	Description
1	683-0147		Idler Bracket Assembly	16	736-0219		Bell Washer .406 I.D. x 1.13 O.D.
2	710-0134		Hex Screw 3/8-24 x 1.00	17	736-0247		Flat Washer 3/8 x 1.25 O.D.
3	710-0191		Hex Screw 3/8-24 x 1.25	18	736-0427		Belleville Washer .567 x 1.125 x .06
4	710-0902		Cap Screw 3/8-24 x 3.75	19	738-0968		Shoulder Spacer
5	710-1611		Pan Head TL Screw 5/16-18 x .75	20	741-0405		Bearing
6	710-3096		Hex Screw 3/8-16 x 2.0 Special	21	750-0705		Spacer
7	712-0116		Jam Lock Nut 3/8-24	22	754-0453		V-Belt
8	712-0241		Hex Nut 3/8-24	23	756-0116		Idler Pulley
9	712-3017		Hex Nut 3/8-16	24	756-0650		Transmission Pulley
10	712-3035		Hex Jam Nut 9/16-18 (Gr. 5)	25	756-0658		Engine Pulley
11	714-0114		Square Key	26	756-0981		Flat Idler Pulley
12	717-0884		Variable Speed Pulley Assembly	27	783-0528		Idler Bracket
13	732-0814		Extension Spring	28	783-0529		Cable Bracket
14	732-0815		Extension Spring	29	736-0169		Lock Washer 3/8 I.D.
15	736-0171		Lock Washer 7/16 I.D.				

# Upper Frame

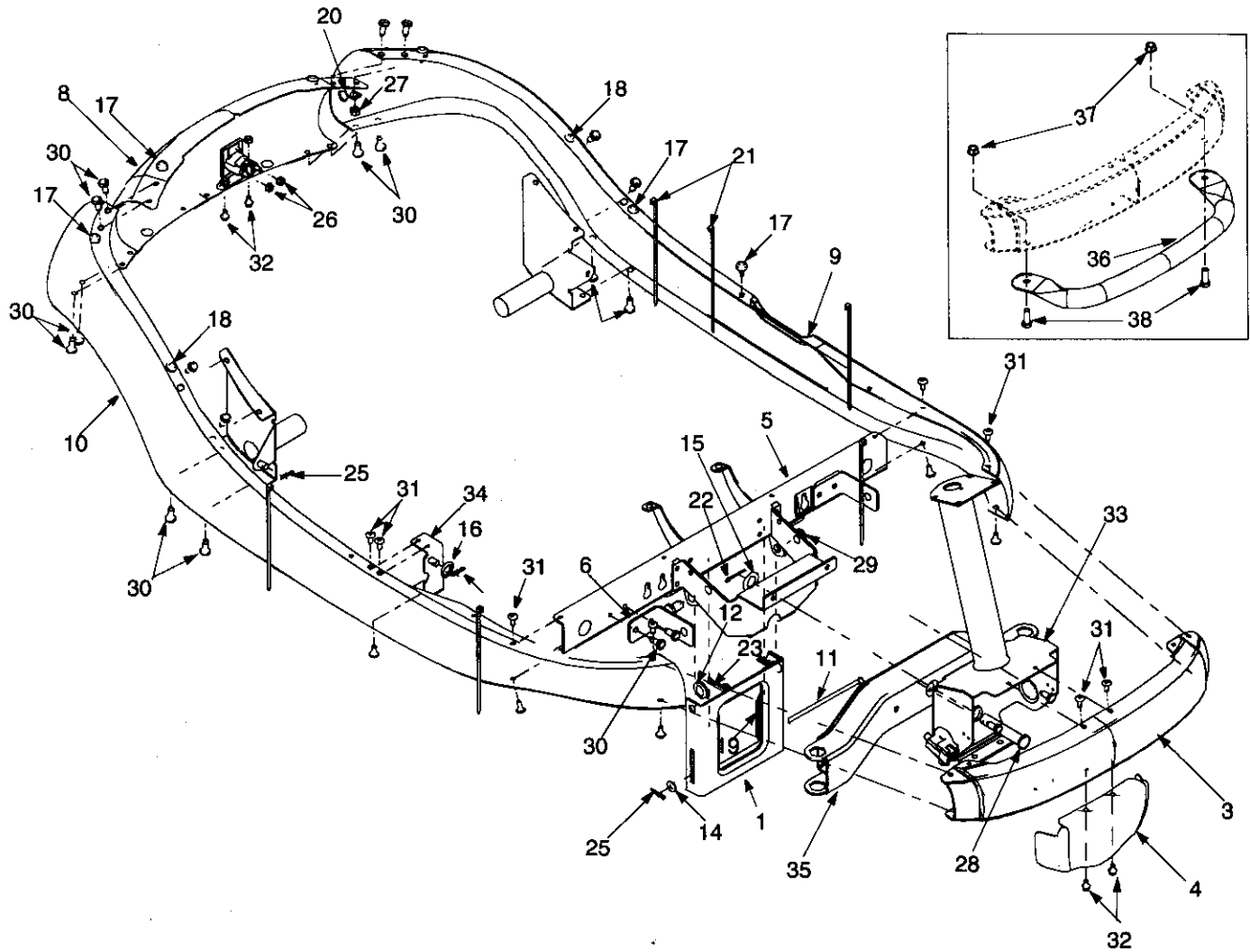

Ref. No.	Part No.	Code	Description	Ref. No.	Part No.	Code	Description
1	783-0605		Deck Stabilizing Bracket	21	725-0157		Cable Tie
3	783-0564A	N	Front Frame: Upper	22	714-0470		Hairpin Clip
4	783-0811	N	Steering Gear Cover	23	714-0147		Hairpin Clip
5	683-0264	N	Front Channel Assembly	25	714-0104		Hairpin Clip
6	783-0554		Cam Bracket	26	712-0271		Hex Nut
8	783-0414A		Frame Rail: Rear	27	712-0265		Hex Nut 1/4-20
9	783-0413		Frame Rail—L.H.	28	711-1165		Clevis Pin
10	783-0412A	N	Frame Rail—R.H.	29	711-0332		Lift Bracket Pin
11	747-0985		Deck Rod	30	710-1611		TT Screw 5/16-18 x .75
12	736-3019		Flat Washer .531 X 1.062 X .134	31	710-1017		Torx Mach. AB Scr. 1/4-14 x 0.625"
14	736-0275		Flat Washer 5/16	32	710-0599		Hex TT Screw 1/4-20
15	736-0187		Flat Washer .64 I.D. X 1.24 X .06	33	683-0163A		Steering Support Bracket
16	736-0101		Flat Washer 3/8 X 1.00 X .030	34	683-0160		Pivot Bracket Ass'y.: Hood
17	735-0271		Rubber Bumper	35	683-0142		Pivot Bar Assembly
18	735-0199A		Rubber Bumper	36	749-1099	N	Front Bumper (Optional)
19	732-0829		Extension Spring	37	712-0431		Lock Nut 3/8-16*
20	726-0272		Clamp: 9/16 dia.	38	710-0514		Hex Bolt 3/8-16 x 1.0" Gr. 5*

\*Applicable only with the optional bumper tube (reference no. 36)

# Frame Assembly

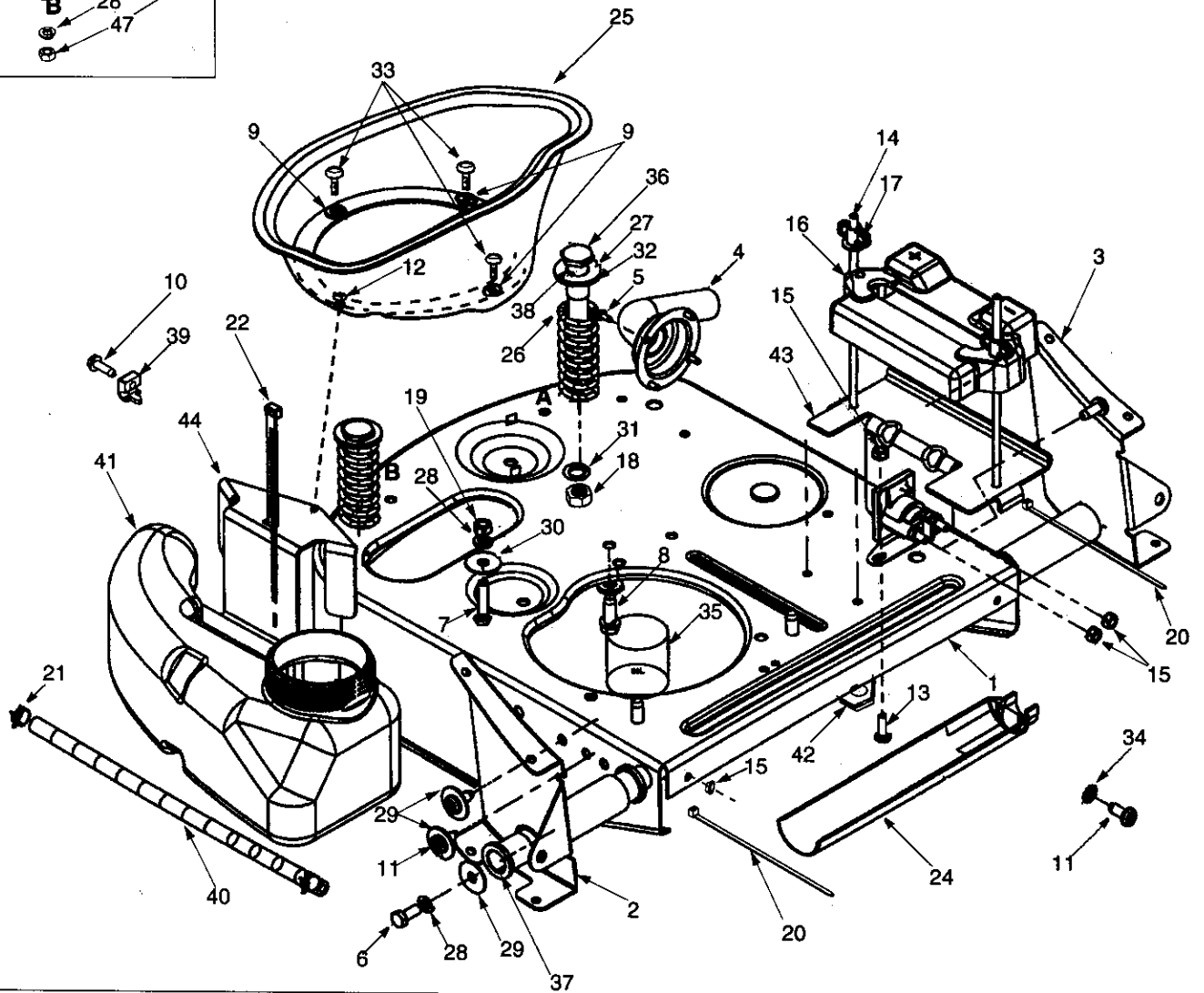
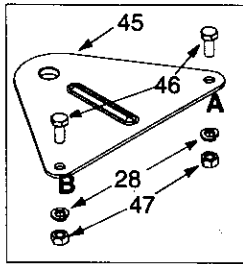

**NOTE:** For painted parts, please refer to the list of color codes below. Please add the applicable color code, wherever needed, to the part number to order a replacement part. For instance, if a part numbered 700-xxxx is painted Oyster Gray, the part number to order would be 700-xxxx-062.

Yard-Man Green: 0665  
 Yard-Man Yellow: 0674  
 Powder Black: 0637

Ref. No.	Part No.	Code	Description	Ref. No.	Part No.	Code	Description
1	683-0149A		Frame Assembly	23	731-0708		Battery Cover
2	683-0190		Frame Rail Support: RH	24	731-1682A		Oil Drain Sleeve
3	683-0191		Frame Rail Support: LH	25	731-1945		Engine Duct
4	683-0192		Muffler Pipe Extension	26	732-3080		Compression Spring
5	710-0148		Hex Fl. Screw #8-32 x 0.375	27	735-0273		Rubber Washer
6	710-0157		Hex Screw 5/16-24 x .75" Gr.5	28	736-0119		Lock Washer
7	710-0624		Hex Screw 5/16-24 x 1.5" Gr.5	29	736-0123		Flat Washer
8	710-0654A		Hex Washer Head TT Screw 3/8-16 x 1.0"	30	736-0159		5/16 Washer
9	710-0871		Hex Slot Sems Screw #10-32 x 0.38	31	736-0169		Lock Washer
10	710-1237		Hex Washer TT Screw #10-32 x 0.625"	32	736-0188		Flat Washer
11	710-1611		TT Screw 5/16-18 x 0.75"	33	736-0400		Flat Washer
12	710-1653		Machine Screw #10-32 x 0.5"	34	736-0607		Lock Washer
13	710-3015		Hex Screw 1/4-20 x 0.75"	35	737-0169		Motor Oil
14	711-0222A		Battery Hold-down Rod	36	738-0960		Shoulder Screw
15	712-0271		Hex Sems Nut 1/4-20	37	741-0516		Flange Bearing
16	712-0291		Lock Nut 1/4-20	38	741-0591		Flange Bearing
17	712-0397		Wing Nut with Bell Washer	39	751B213146		Throttle Casing Clamp
18	712-3017		Hex Nut	40	751-0535		Fuel Line Hose
19	712-3057		Hex Nut 5/16-24 Gr.5	41	751-0656		Fuel Tank
20	725-0157		Cable Tie	42	783-0417		Transaxle Support Bracket
21	726-0205		Hose Clamp	43	783-0624		Battery Bracket
22	726-0209		Cable Tie	44	783-0630		Fuel Tank Bracket
				45	783-0561		Hitch Plate (Optional)
				46	710-0118		Hex Bolt*
				47	712-0267		Hex Nut*

\*Applicable only with the optional hitch plate (reference no. 45)

# Hood Assembly

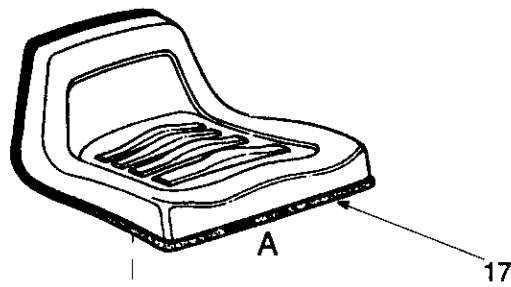

**NOTE:** For **paint**ed parts, please refer to the list of color codes below. Please add the applicable color code, wherever needed, to the part number to order a replacement part. For instance, if a part numbered 700-xxxx is painted Oyster Gray, the part number to order would be 700-xxxx-062.

Yard-Man Green: 0665  
 Yard-Man Yellow: 0674  
 Powder Black: 0637

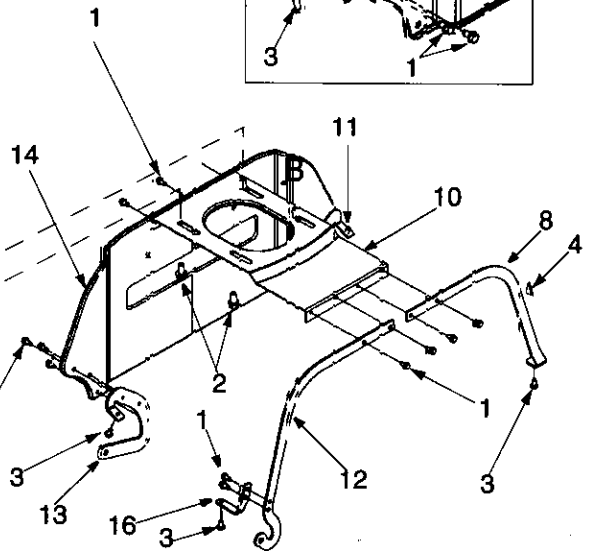
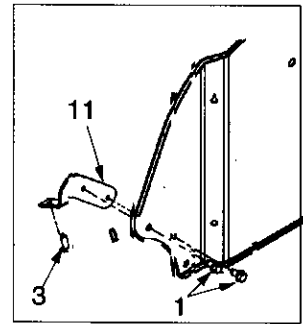
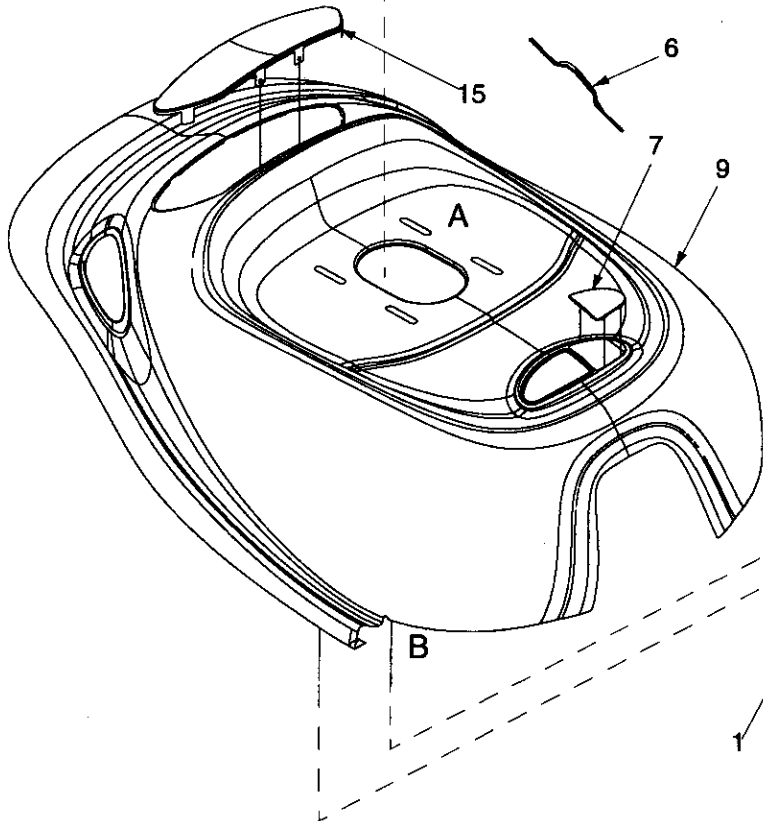

Ref. No.	Part No.	Code	Description	Ref. No.	Part No.	Code	Description
1	710-0599		Hex Hd. TT Screw 1/4-20 x 0.5	9	783-0445		Hood
2	710-0870		Hex Washer Hd. TT Screw 3/8-16 x 0.62	10	783-0446		Plate: Hood
3	710-1017		Torx Head AB screw 1/4-14 x 0.625	11	783-0447		Hood Bracket
4	720-0238		Rod End Grip	12	783-0448		Hood Bracket: Reinforcement
5	720-3026		Edge Trim	13	783-0449		Hinge Bracket: Rear
6	731-0511		Trim Strip	14	783-0451A		Pivot Plate: Rear Hood
7	731-1691		Grass Bag Lens	15	783-0545		Hood Screen
8	783-0410		Bracket Reinforcement: Hood	16	783-0562		Hinge Bracket: Front
				17	757-0364A		Seat

# Wheel Assembly

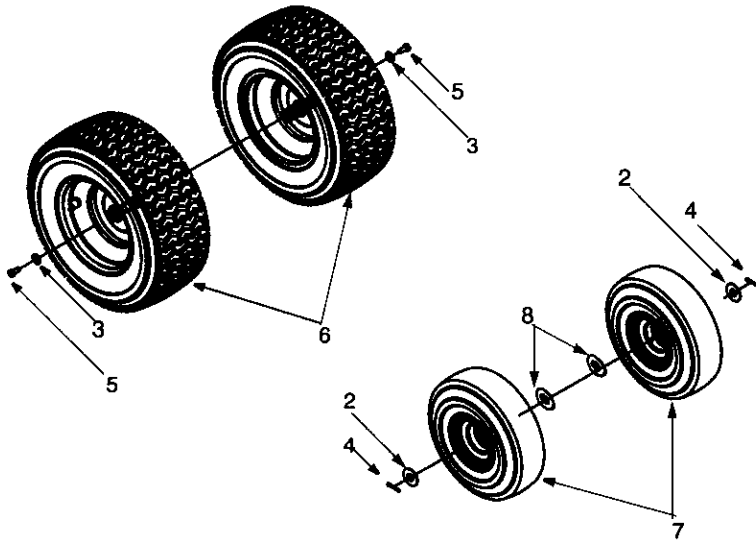

Ref. No.	Part No.	Code	Description
1	737-0288		Grease Fitting (Not Shown)
2	736-0285		Flat Washer .635 x 1.589 x .060
3	736-0242		Bell Washer .345 I.D. x .88 O.D. x .06
4	714-0115		Hairpin Clip
5	710-0627		Hex Screw 5/16-24 x .75
6	634-0139		Rear Wheel 16.0 x 6.5 x 8.0
7	634-0169		Front Wheel 11.0 x 4.0 x 4.0
8	736-0366	N	Flat Washer 5/8 I.D. x 1.0 O.D.

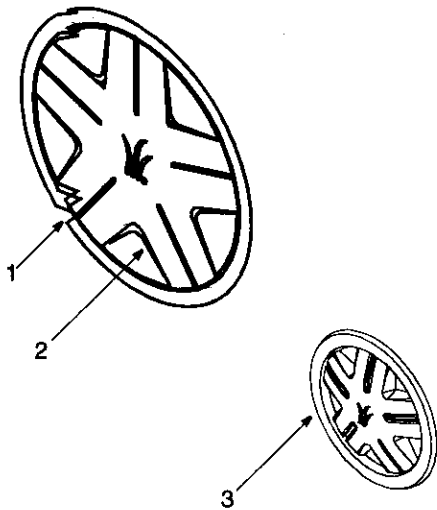

Ref. No.	Part No.	Code	Description
1	727-0425A		Spring Clip
2	731-1825		Hubcap: Yellow—4.0"
3	734-1788A		Hubcap: Yellow—8"

# Three-In-One Mowing Deck

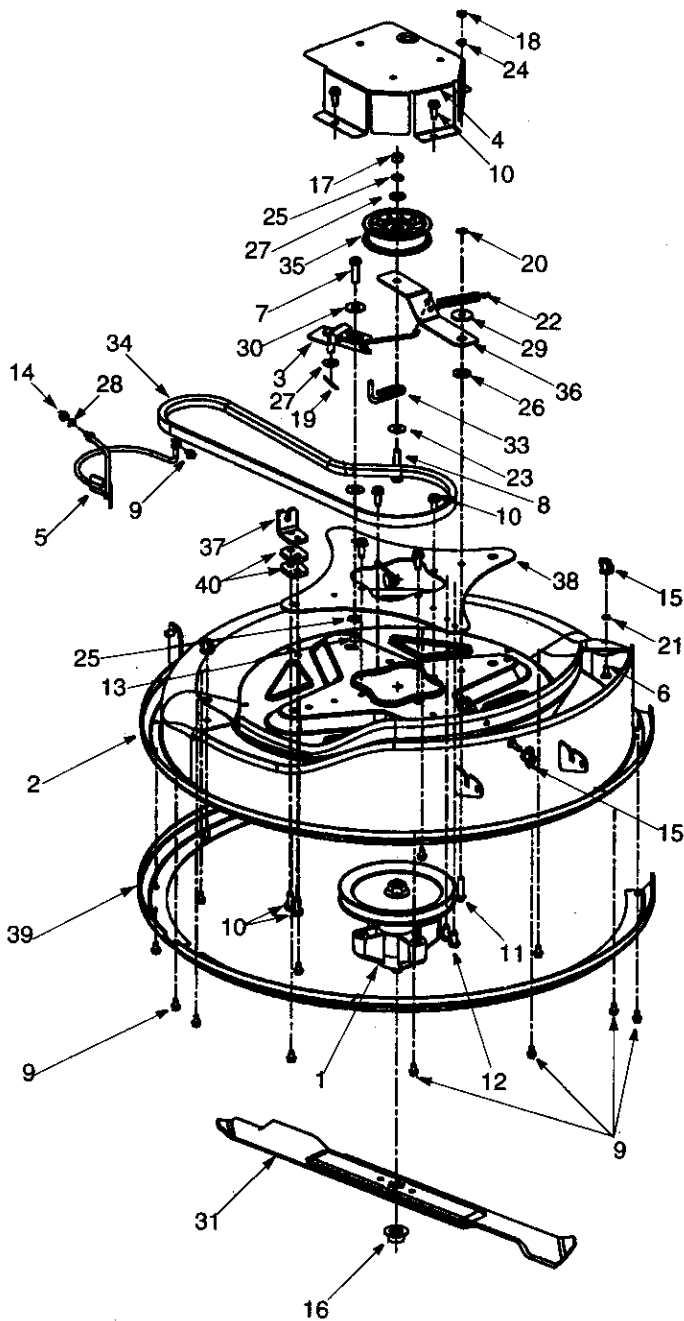

**NOTE:** For painted parts, please refer to the list of color codes below. Please add the applicable color code, wherever needed, to the part number to order a replacement part. For instance, if a part numbered 700-xxx is painted Oyster Gray, the part number to order would be 700-xxx-062.

Yard-Man Green: 0665  
 Yard-Man Yellow: 0674  
 Powder Black: 0637

Ref. No.	Part No.	Code	Description
1	618-0250		Spindle Assembly
2	683-0150C	N	Deck Assembly
3	683-0159		Brake Bracket Assembly
4	683-0173		Deck Belt Cover
5	747-1172	N	Belt Keeper
6	710-0134		Carriage Screw 1/4-20 x .62
7	710-0191		Hex Bolt 3/8-24 x 1.25 Grade 8
8	710-0347		Hex Screw 3/8-16 x 1.75 Gr. 5
9	710-0599		Self-Tapping Washer Head Hex Screw 1/4-20 x .5
10	710-0650		Hex Washer Self-Tapping Screw 5/16-18 x .75
11	710-0672		Hex Cap Scr. 5/16-24 x 1.25 (Gr. 5)
12	710-1611		Torx Head Screw 5/16-18 x .75
13	712-0241		Hex Nut 3/8-24
14	712-0287		Hex Nut 1/4-20
15	712-0397		Wing Nut With Bell Washer
16	712-0417A		Flange Nut 5/8-18
17	712-3017		Hex Nut 3/8-16
18	712-3057		Hex Nut 5/16-24
19	714-0470		Cotter Pin
20	726-0201		Speed Nut
21	726-0233		Push Nut
22	732-0429A		Extension Spring
23	736-0101		Flat Washer 3/8 x 1.00 x .030
24	736-0119		Lock Washer 5/16
25	736-0169		Lock Washer 3/8
26	736-0289		Bushing
27	736-0300		Flat Washer .406 x .875 x .059
28	736-0329		Lock Washer
29	736-0343		Flat Washer .330 x 1.25 x .120
30	738-0968		Spacer
31	742-0651		Three-in-one Blade
32	747-0957		Link Rod
33	747-0972		Belt Keeper
34	754-0754		V Belt
35	756-0627		Flat Idler Pulley
36	783-0463		Idler Bracket
37	783-0529		Cable Bracket
38	783-0569A		Deck Plate
39	783-0781	N	Deck Skirt
40	783-0594		Deck Cable Bracket

# Deck Accessory—Three-In-One

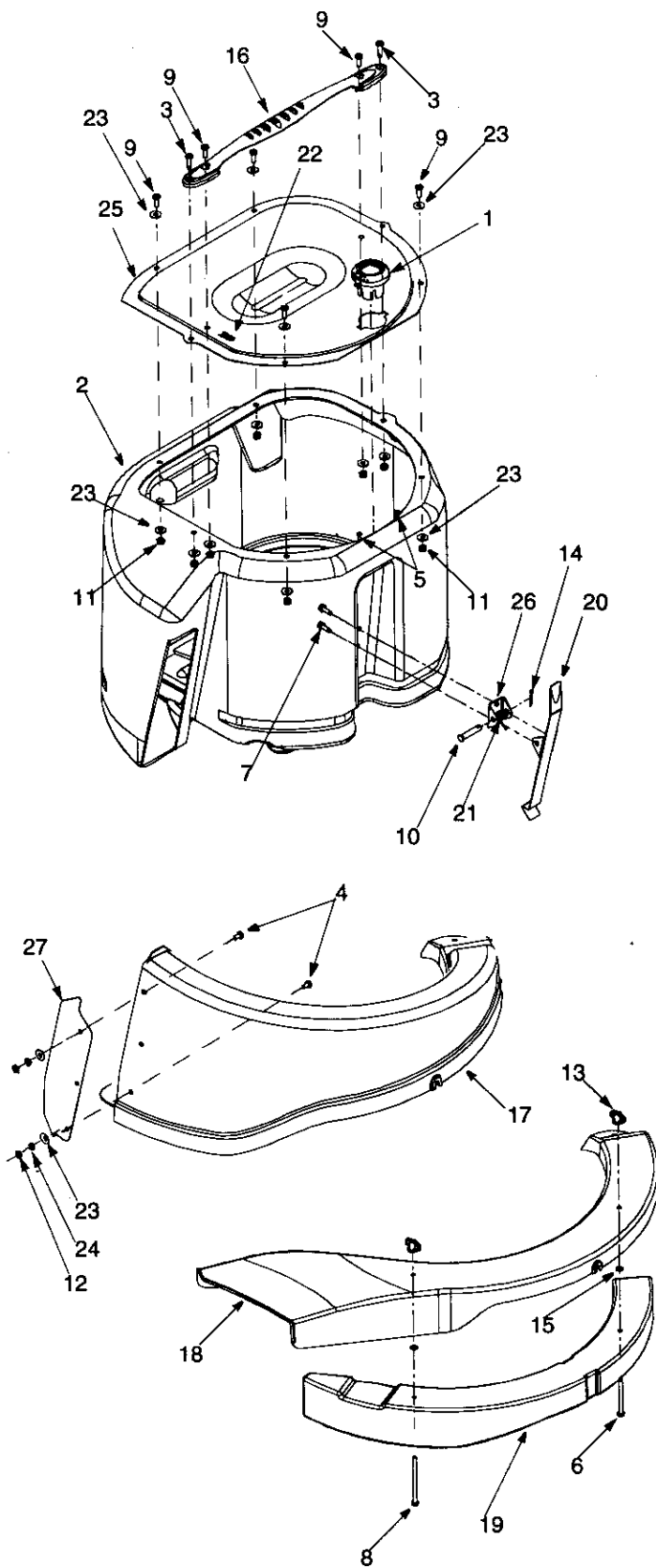

Ref. No.	Part No.	Code	Description
1	631-0060	N	Flow Indicator Assembly
2	631-0080		Grass Bag Assembly
3	710-0166		Machine Screw 1/4-20 x 1.0
4	710-0286		Machine Screw 1/4-20 x 0.5"
5	710-0456		Hex Screw #10-16 x 0.5"
6	710-0564		Hex Screw 1/4-20 x 2.75"
7	710-0642		Self-Tapping Screw 1/4-20 x 0.75"
8	710-0825		Hex Screw 1/4-20 x 3.75"
9	710-0924		Machine Screw 1/4-20 x 0.75"
10	711-0415		Clevis Pin
11	712-0271		Hex Sems Nut 1/4-20
12	712-0298		Jam Nut
13	712-0397		Wing Nut
14	714-0115		Cotter Pin
15	726-0271		Speed Nut
16	731-1441		Bag Handle
17	731-1743A		Discharge Chute: Grass Bag
18	731-1744		Side-Discharge Chute
19	731-1745A		Mulching Plug
20	732-0839		Bag Release Lever
21	732-0841		Torsion Spring
22	732-0854		Clip Spring
23	736-0173		Flat Washer
24	736-0329		Lock Washer
25	783-0544		Grass Bag Screen
26	783-0575A		Pivot Bracket
27	783-0645		Deflector Plate



# Wire Diagram

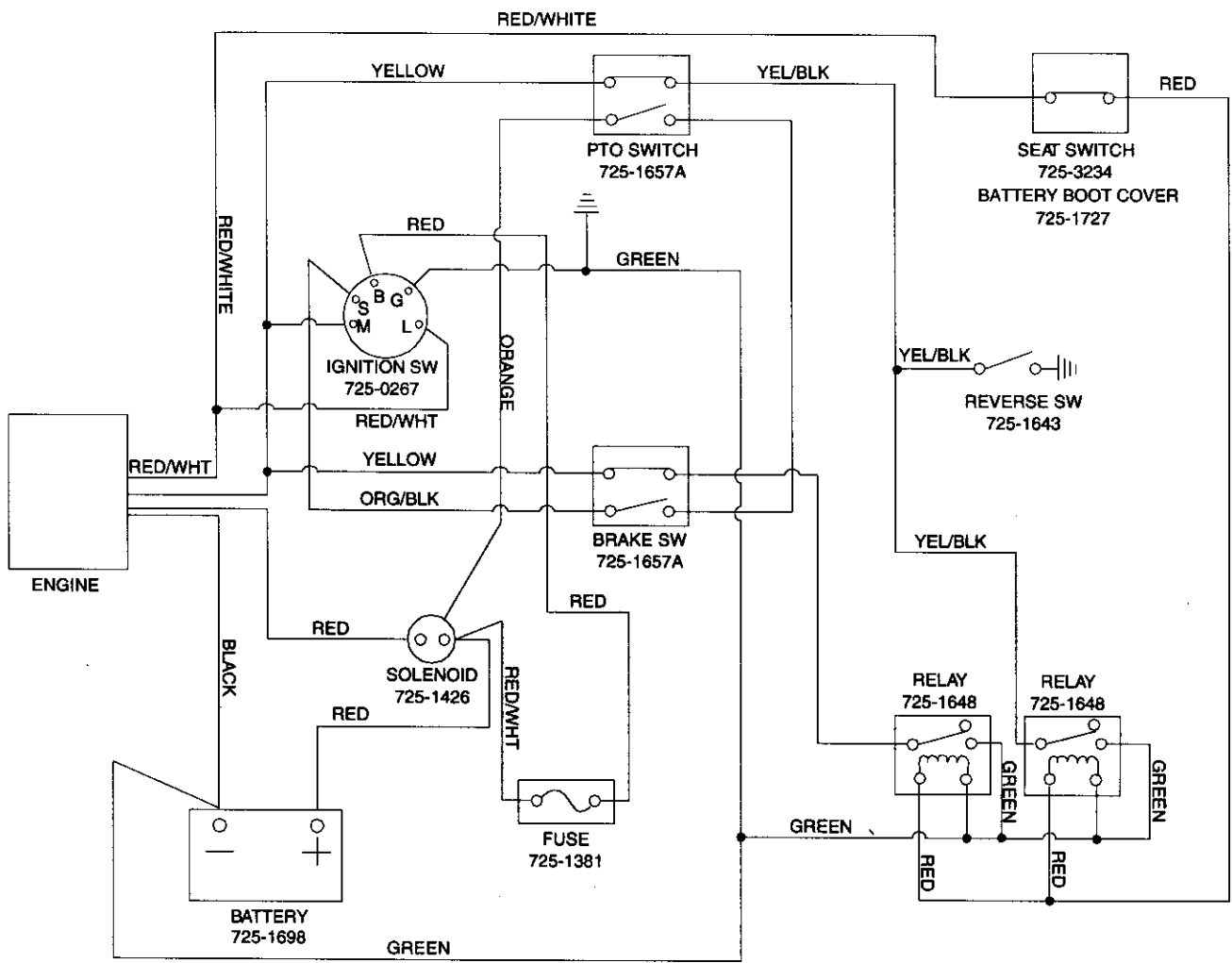

**COMPLETE WIRE HARNESS (629-0902)**

Single Speed Transmission—L.H. (Part No. 618-0251A)

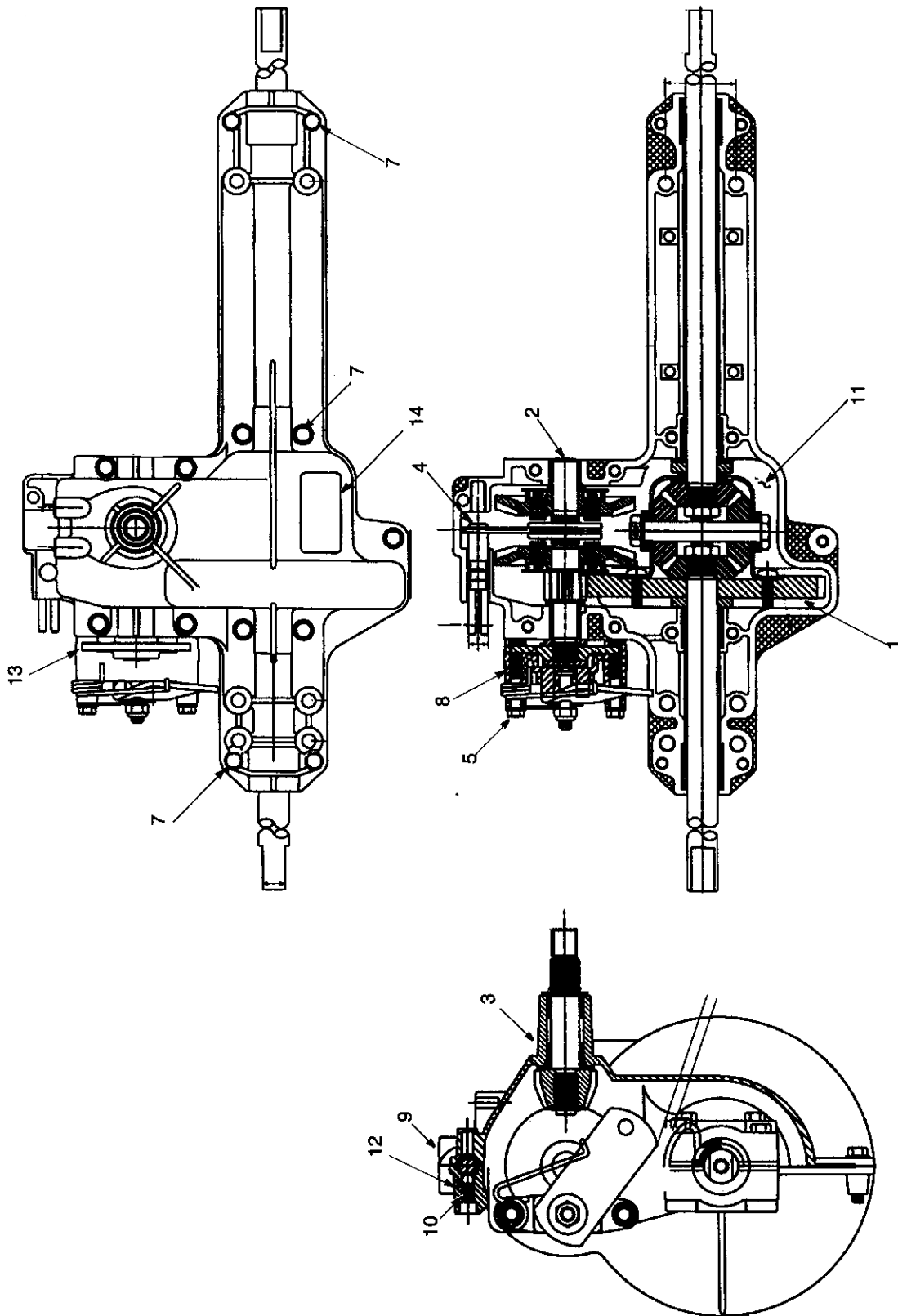

Ref. no.	Part No.	Code	Description
1	618-0232		Differential Assembly: Single Speed
2	618-0248		Drive Shaft assembly: LH Brake
3	618-0072B		Upper Housing Assembly
4	611-0114		Detent Shaft Assembly
5	661-0006		Brake Yoke Assembly: LH
6	710-1206		Hex Washer Hd. TT Screw 1/4-20 x 2.37 Gr.5
7	710-1325		Hex Washer Hd. TT Screw 1/4-20 x 1.65
8	717-0678		Brake Puck
9	719-0313B		Lower Housing
10	732-0863		Spring Detent
11	737-0148		Grease
12	741-0862		Ball Detent
13	761-0202		Brake Disc
14	777-6318		Label

# MANUFACTURER'S LIMITED WARRANTY FOR:



For TWO YEARS from the date of retail purchase within the United States of America, its possessions and territories, MTD PRODUCTS INC will, at its option, repair or replace, for the original purchaser, free of charge, any part or parts found to be defective in material or workmanship. This warranty covers units which have been operated and maintained in accordance with the operating instructions furnished with the unit, and which have not been subject to misuse, abuse, commercial use, neglect, accident, improper maintenance or alteration.

Normal wear parts or components thereof are subject to separate terms as noted below in the "No Fault Ninety Day Consumer Warranty" clause.

All normal wear part failures will be covered on this product for a period of 90 days regardless of cause. After 90 days, but within the two year period, normal wear parts failures will be covered ONLY IF caused by defects in material or workmanship of OTHER component parts. Normal wear parts are defined as batteries\*, belts, blades, blade adapters, grass bags, rider deck wheels, seats, snow thrower skid shoes, shave plates and tires.

**How to obtain service:** Warranty service is available, with proof of purchase, through your local authorized service dealer. To locate the dealer in your area, please check the yellow pages or contact the Customer Service Department of MTD PRODUCTS INC, P. O. Box 368022, Cleveland, Ohio 44136-9722. Phone 1 (800) 800-7310. The return of a complete unit will not be accepted by the factory unless prior written permission has been extended by the Customer Service Department of MTD PRODUCTS INC.

**Transportation charges:** Transportation charges for the movement of any power equipment unit or attachment are the responsibility of the purchaser.

**Units exported out of the United States:** MTD PRODUCTS INC does not extend any warranty for

products sold or exported outside of the United States of America, its possessions and territories, except those sold through MTD PRODUCTS INC's authorized channels of export distribution.

#### **Other Warranties:**

1. The engine or component parts thereof carry separate warranties from their manufacturers. Please refer to the applicable manufacturer's warranty on these items.
2. \*Batteries are covered by a 90-day replacement warranty.
3. Log splitter pumps, valves and cylinders or component parts thereof are covered by a one year warranty.
4. All other warranties, express or implied, including any implied warranty of merchantability or fitness for a particular purpose, are hereby expressly disclaimed in their entirety.
5. The provisions as set forth in this warranty provide the sole and exclusive remedy of MTD PRODUCTS INC's obligations arising from the sales of its products. MTD PRODUCTS INC will not be liable for incidental or consequential loss or damage.

**How state law relates to this warranty:** This limited warranty gives you specific legal rights, and you may also have other rights which vary from state to state. Certain disclaimers are not allowed in some states and therefore they may not apply to you under all circumstances.

**NOTE:** This warranty does not cover routine maintenance items such as lubricants, filters, blade sharpening and tune-ups, or adjustments such as brake adjustments, clutch adjustments or deck adjustments. Nor does this warranty cover normal deterioration of the exterior finish due to use or exposure.