

Fisher & Paykel

Installation Instructions

DishDrawer™

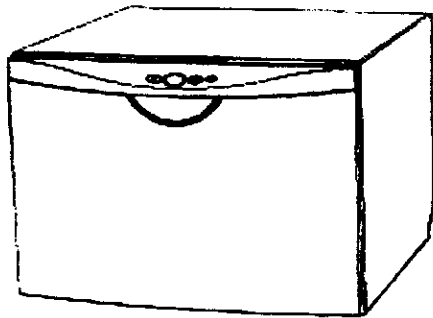

DS602 (Prefinished)

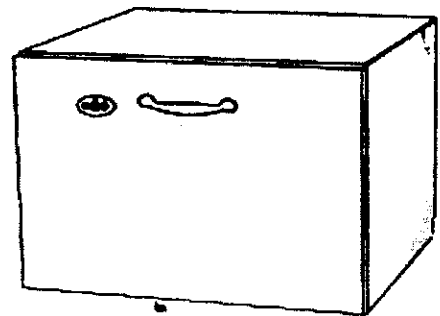

DS602I (Integrated)

Part No. 525854/B

Models DS602 DS602I

NOTE TO THE INSTALLER

- Be sure to leave these instructions with the Customer.
- Ensure this appliance is properly grounded.

NOTE TO THE CONSUMER

- Keep these Installation Instructions with your Use & Care Manual for future reference.



IMPORTANT

- Read these Instructions completely and carefully.
- Observe all governing Codes and Ordinances.



WARNING

- These Instructions are intended as a guide only.
- It is the responsibility of the plumber and electrician to ensure that each installation complies with all Codes and Ordinances.
- Installation of this DishDrawer requires basic mechanical and electrical skills.
- The installer is responsible for the DishDrawer installation. Improper installation is not covered under the Express Warranty Form.



IMPORTANT

- At the completion of the DishDrawer installation, the Installer must perform Final Checks as per Section 8 of these Installation Instructions.

Single DishDrawer

Table of Contents

Section 1	General Information
1.1	Preparation
1.2	Product Specifications
1.3	Cavity Dimensions
1.4	Tools Needed to Install DishDrawer
1.5	Product Parts - Prefinished Single
1.6	Product Parts - Integrated Single
Section 2	Electrical, Plumbing & Drainage Information
2.1	Electrical
2.2	Grounding Instructions
2.3	Plumbing - Water Supply
2.4	Plumbing - Drainage Options
Section 3	Fitting the Single DishDrawer
3.1	Single DishDrawer Mounting Hole Locations
3.2	Connecting the Services
3.3	Flexible Extrusion Attachment for 24" Cavity
Section 4	Inserting Single DishDrawer Into Cavity
Section 5	Information for Cabinet Maker for Integrated DishDrawer
5.1	Points to Consider
5.2	Integrated Overview
5.3	Integrated Drawer Front Dimensions
5.4	Shelf & Integrated Drawer Front Preparation
Section 6	Integrated Drawer Front Installation
6.1	Changing the Integrated Badge Enclosure
6.2	Disassembling the Integrated Badge Assembly
6.3	Assembling the Integrated Badge
6.4	Fitting the Badge, Handle & Mounting Panel to the Drawer Front
6.5	Fitting the Drawer Front to the DishDrawer
Section 7	Final Fitting For Single DishDrawer
Section 8	Final Checks
8.1	Installation Wet Test
8.2	Troubleshooting

SECTION 1



WARNING

Before installing the DishDrawer, remove the house fuse or open the circuit breaker.

Ensure all water connections are turned OFF.



WARNING

The DishDrawer **MUST** be installed to allow for future removal from the enclosure if service is required.

GENERAL INFORMATION

STEP 1.1 PREPARATION

Ensure the DishDrawer enclosure is prepared for installation.

Remove all packaging and materials supplied with the DishDrawer.

If you have any questions concerning the installation of this DishDrawer, contact:

Fisher & Paykel Customer Care Centre
TOLL FREE 1-888-9-FNP USA
TOLL FREE 1-888-9-367 872
Fax (714) 829 8699
WWW.FISHERPAYKEL.COM

22982 Alcalde Drive
Suite 201
Laguna Hills
CA 92653 USA

STEP 1.2 PRODUCT SPECIFICATIONS

Weight - Full	93lb (Prefinished)
- Empty	62lb (Prefinished)
Electrical	110-120VAC 3 pin socket outlet
Drying	Residual Heat & Fan Assisted
Water Connection	Recommended Hot 140°F Max.
Water Pressure	Maximum 120 p.s.i. Minimum 4.3 p.s.i.

(Water pressure below 7 p.s.i. may need the electronics re-programmed by a Service Person at the time of installation)

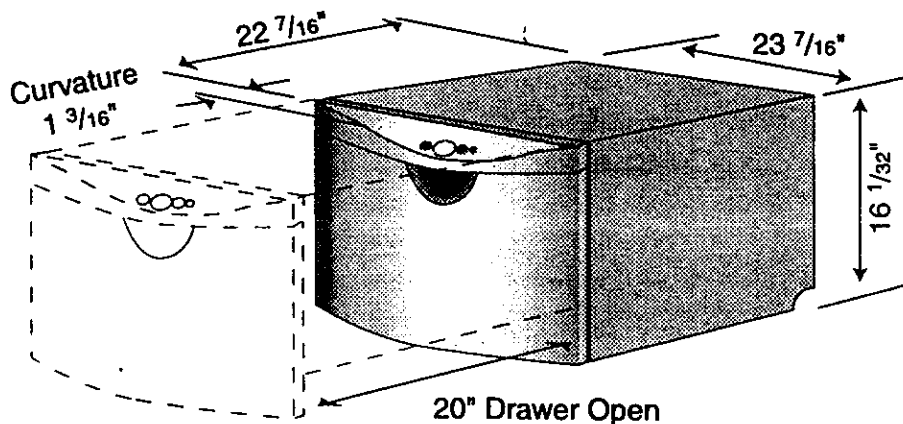

STEP 1.3 CAVITY DIMENSIONS

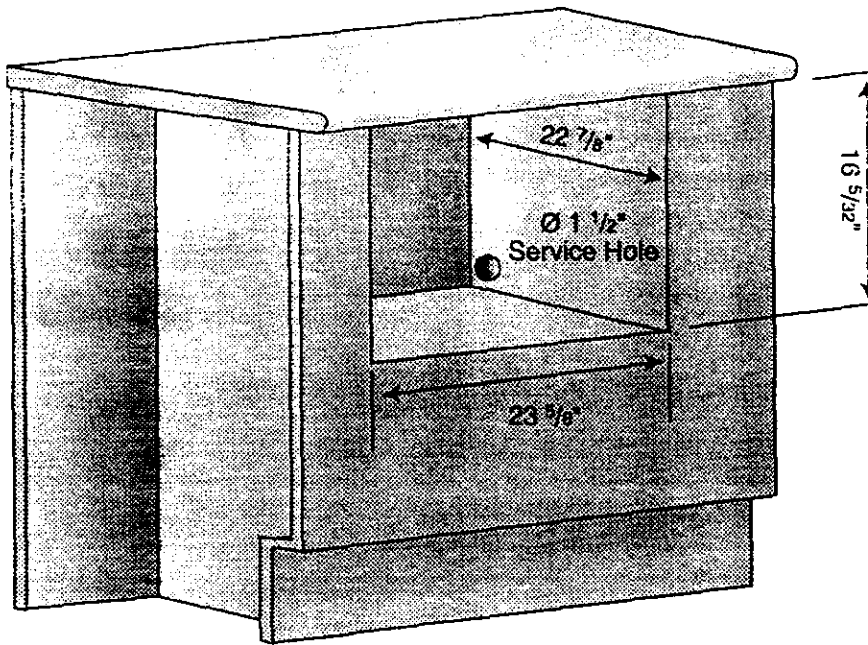

! IMPORTANT

Where the DishDrawer is in an under counter situation, i.e. built into a kitchen unit, it is recommended that bare wood surrounding the DishDrawer is sealed with an oil based paint or polyurethane to prevent possible steam damage.

! IMPORTANT

If mounting the DishDrawer near the bottom of the cabinet, ensure there is adequate room underneath the supporting cabinet to tighten bolts.

! IMPORTANT

Ensure the cavity sides are plumb (vertical) as this will assist with leveling the DishDrawer.

! IMPORTANT

Ensure the Services Hole is as close as possible to the rear corner of the cabinet. The hole can be located on either side depending on the location of the services.

! IMPORTANT

Ensure that there is a 2" gap between adjacent cabinetry and sides of drawers.

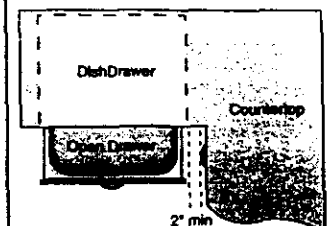

STEP 1.4 TOOLS NEEDED TO INSTALL DISHDRAWER

- Wooden Chopping Board
- Level
- Safety Glasses
- Utility Knife
- Pencil
- Drill & Drill Bits ($\frac{3}{16}$ ", $\frac{1}{16}$ " & $\frac{1}{32}$ ")
- Sandpaper
- Tape Measure
- Square
- Ruler
- Phillips Screwdriver
- Pliers
- Adjustable Wrenches (x2)
- $\frac{7}{32}$ " (6mm) Allen Key (Integrated Models)
- Router (Integrated Models)
- Jigsaw (Integrated Models)

STEP 1.5 PRODUCT PARTS - PREFINISHED SINGLE

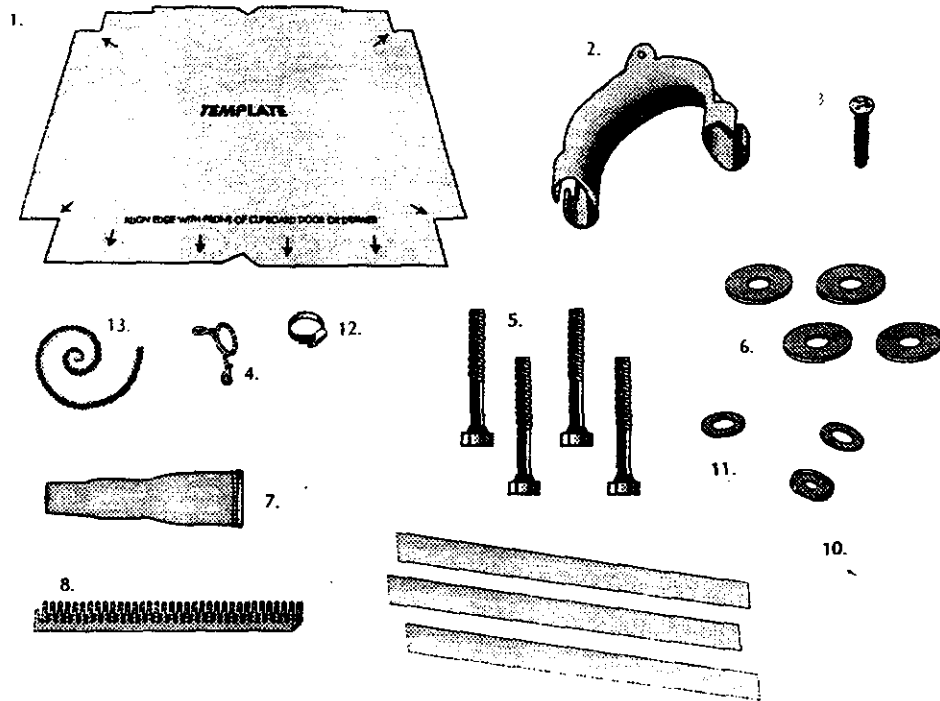

1. Foot Template - Single (1)
2. Drain Hose Support (1)
3. Screw (1)
4. Wire Clip (1)
5. M8 Bolts (4)
6. Washers (4)
7. Single Connector (1)
8. Edge Protector (1)
9. Flexible Extrusion (3)
10. Solderless Lug & Washer (1)
11. Inlet Hose Washer (1)
12. Hose Clamp (1)
13. Seal Lower Cabinet (1)

STEP 1.6 PRODUCT PARTS - INTEGRATED SINGLE

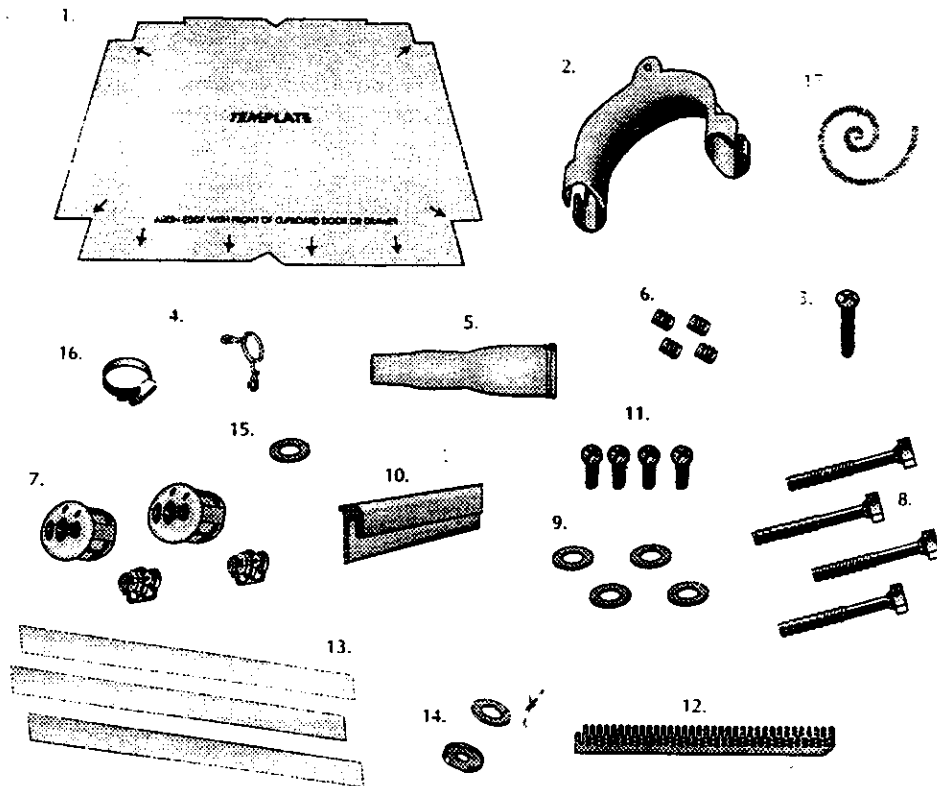

1. Template (Single 1)
2. Drain Hose support (1)
3. Screw (1)
4. Wire Clip (1)
5. Single Connector (1)
6. Mounting Bracket Nuts (4)
7. Badge Kit (2)
8. M8 Bolts (4)
9. Washers (4)
10. Seal (1)
11. Door Screws (4)
12. Edge Protector (1)
13. Flexible Extrusion (3)
14. Solderless Lug & Washer (1)
15. Inlet Hose Washer (1)
16. Hose Clamp (1)
17. Seal Lower Cabinet (1)

SECTION 2

ELECTRICAL, PLUMBING & DRAINAGE INFORMATION



WARNING

Improper connection of the equipment-grounding conductor can result in a risk of electric shock. Check with a qualified electrician or service representative if you are in doubt as to whether the appliance is properly grounded.

Do not modify the plug provided with the appliance - if it will not fit the outlet, have a proper outlet installed by a qualified electrician.



WARNING

The Drain Hose Support must be at least 30" above the floor to prevent siphoning of the water during the wash cycle.

It is recommended that the Drain Hose Support is secured in place using the screw tab.

Ensure that the drain hoses are fully extended.

STEP 2.1 ELECTRICAL



Care should be exercised when the appliance is installed or removed, to reduce the likelihood of damage to the power supply cord.

If the power supply cord is damaged, it must be replaced by the Manufacturer, its Service Agent or a similarly qualified person, in order to avoid a hazard.

The power supply receptacle for the appliance should be installed in a cabinet or on a wall adjacent to the undercounter space in which the appliance is to be installed.

The power supply receptacle should be positioned between 6" and 18" from the cabinet opening of the DishDrawer.

STEP 2.2 GROUNDING INSTRUCTIONS



This appliance must be grounded. In the event of malfunction or breakdown, grounding will reduce the risk of electric shock by providing a path of least resistance for electric current.

This appliance is equipped with a cord having an equipment-grounding conductor and a grounding plug. The plug must be plugged into an appropriate outlet that is installed and grounded in accordance with all local Codes & Ordinances.

STEP 2.3 PLUMBING - WATER SUPPLY



- a) The water connection is to be made to a hot water supply only. Ensure the water temperature is not greater than 140°F.
- b) A readily accessible shut off valve must be installed in the supply pipe.
- c) The water supply pressure is to be between 4.3 p.s.i. minimum and 120 p.s.i. maximum.
- d) The inlet supply hose must be connected to the water supply using a 3/8" compression type water supply fitting.
- e) Ensure sealing washer supplied with connection hose is fitted.

STEP 2.4 PLUMBING - DRAINAGE OPTIONS

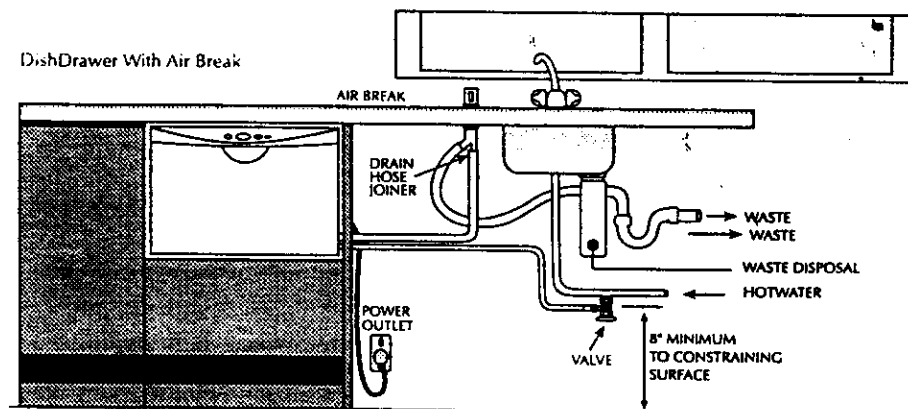
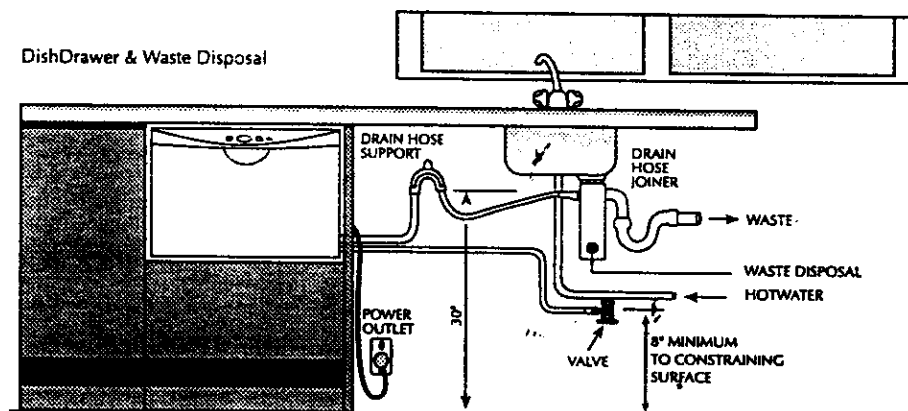
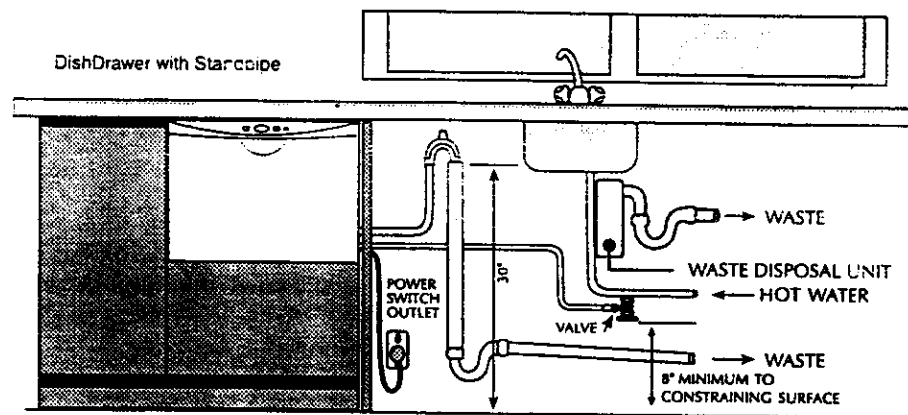

Note: DS602 Prefinished Model is shown. There is no variation in plumbing between DS602 Prefinished Model and DS6021 Integrated Model.

Options 1 and 2 are the preferred options.

SECTION 3

FITTING THE SINGLE DISHDRAWER

STEP 3.1 SINGLE DISHDRAWER MOUNTING HOLE LOCATIONS



TIP

Ensure the cavity is at least 22⁷/₈" deep.



IMPORTANT

For Integrated product with door thickness other than 3/4", the Template position must be adjusted forward or back to allow for this difference.

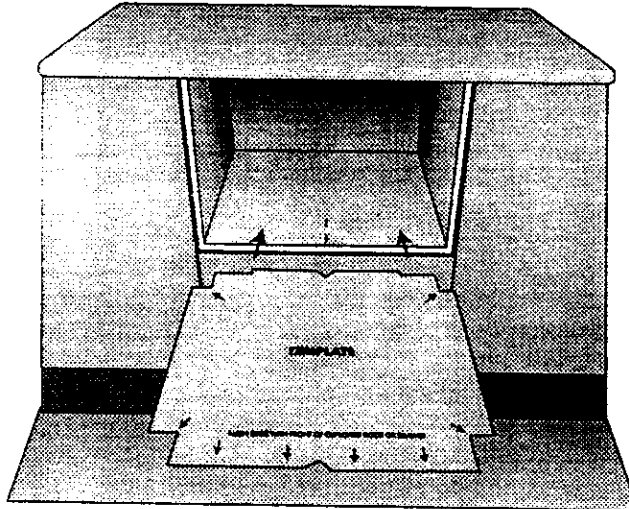

1.

Draw the cavity center line on the supporting cabinetry.

2.

Center Template in cavity using V-notch on the front of the Template.

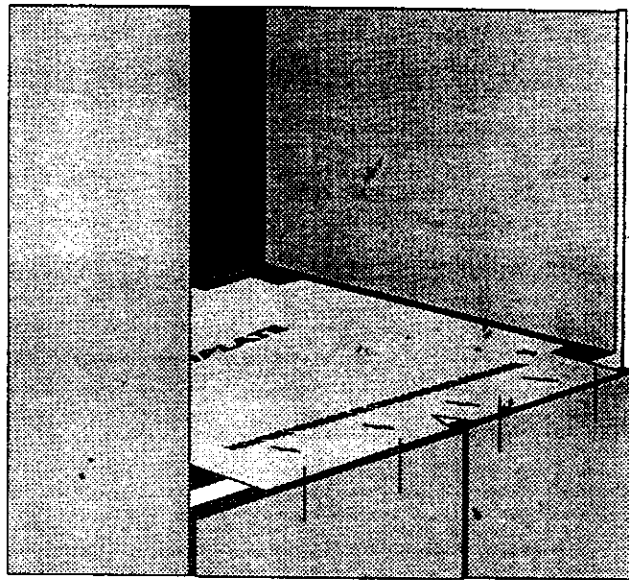

3.

Align front of Template to suit surround of cabinetry.

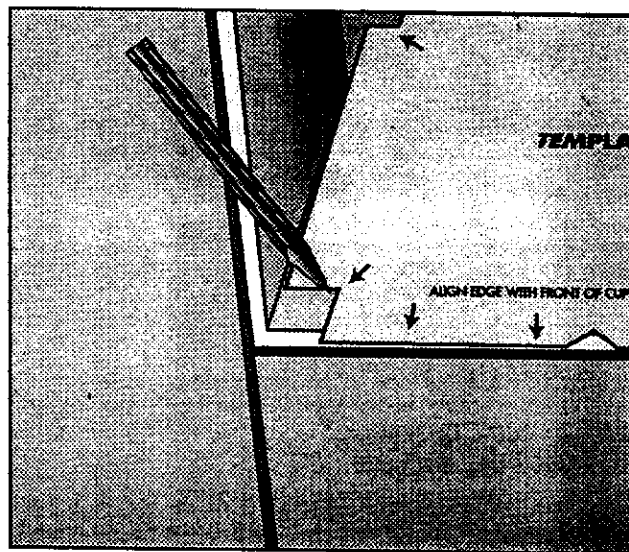

4.

Mark and drill four 15/32" diameter holes as described on Template.

STEP 3.2 CONNECTING THE SERVICES

1.

Feed the Power Cord, Inlet Hose and Drain Hose through the Services Hole. Position the DishDrawer in front of the opening.

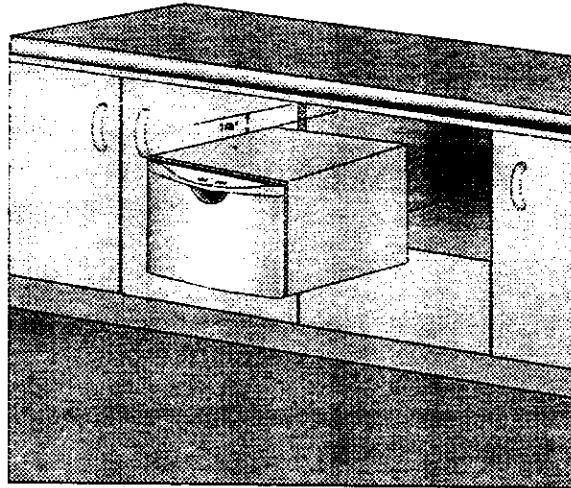

2.

Connect the Inlet Hose to the **HOT WATER SUPPLY**. Ensure the sealing washer supplied with the accessories is fitted.

Hose coupling must be tightened a further half turn after seal contact.

3.

If required, the Drain Hose may be trimmed to a suitable length.

4.

If an air break option is not chosen, then the Drain Hose Support must be used and positioned at least 30" above the floor to prevent siphoning of the water during the wash cycle. (See Step 2.4 - Plumbing - Drainage Options.)

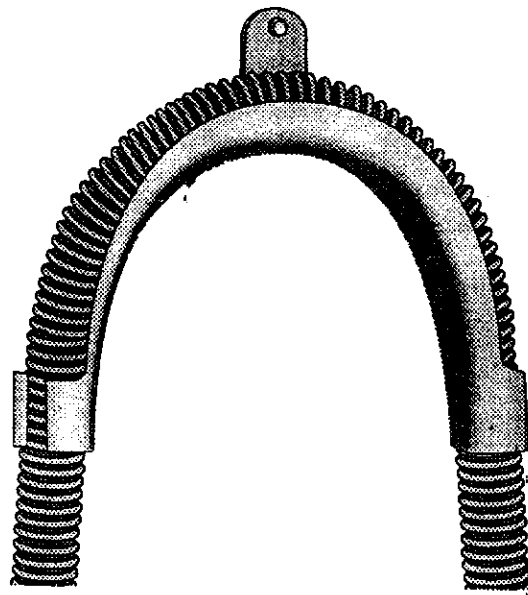

5.

When using a standpipe option, hose should not extend further than 2" down the standpipe in order to prevent siphoning.

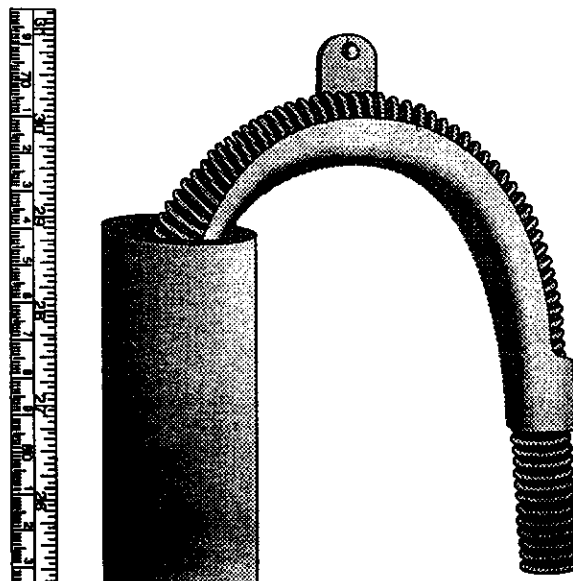

! WARNING

Ensure the edges of the Service Hole are smooth or covered. (See Step 1 - Cavity Dimensions.) If the Service Hole is through a metal partition, the note must be protected with the Edge Protector provided.

! WARNING

DO NOT adjust the length of the Inlet Hose.

💡 TIP

Turn the water valve ON to check for any leaks, before pushing the DishDrawer back into its cavity.

! WARNING

Attach the Drain Hose Support to the cabinet cabinetry to prevent siphoning and to keep the Drain Hose from kinking.

6. If required, trim the Single Connector to the size which matches the waste tee or air break to be used. There are ribs provided to guide cutting.

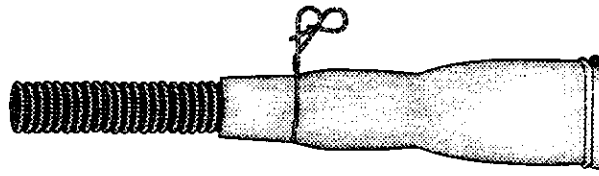

7. When using the Single Connector, the hose should be pushed in firmly, 5 clicks.

Remember to slip the Wire Clip over the Drain Hose before connecting to the Single Connector.

The supplied Wire Clip should be installed between the two positioning ribs on the Single Connector.

Attach Single Connector to waste tee. (See Step 2.5) Ensure snug fit using the supplied hose clamp.

8. Ensure there is a power outlet in reach of the supplied flex. If there is not a suitable outlet available then have one installed by a qualified electrician.

DO NOT modify the power plug supplied with the DishDrawer or use an extension cord, adaptor plug or multiple outlet box.



WARNING

The Product **MUST NOT** be plugged in at this stage.

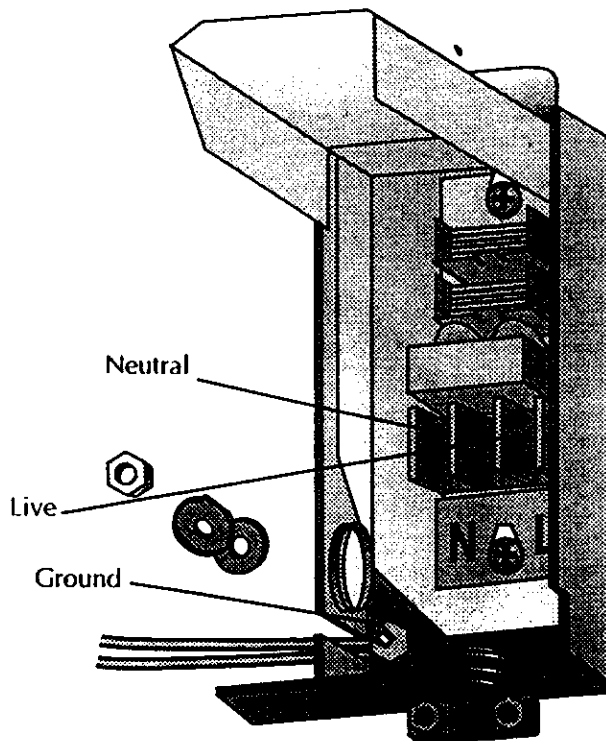

9.

Alternatively, the DishDrawer may be permanently connected to flexible conduit.

Remove the flex and cable clamp. Fit suitable cable clamp for the conduit and terminate the wiring as shown.

Use the solderless lug and washer supplied with the product parts to terminate the ground wire.

STEP 3.3 FLEXIBLE EXTRUSION ATTACHMENT FOR 24" CAVITY

Flexible Extrusions are supplied to enable the installer to help fill any excess space between the sides of the DishDrawer and the cavity. The two lengths of Flexible Extrusion (supplied) should be attached before pushing the DishDrawer into the cavity for final installation. This Extrusion is designed to fit a 24" width cavity.



TIP

Wiring, Plumbing and Services should be completed before attaching the flexible extrusion.

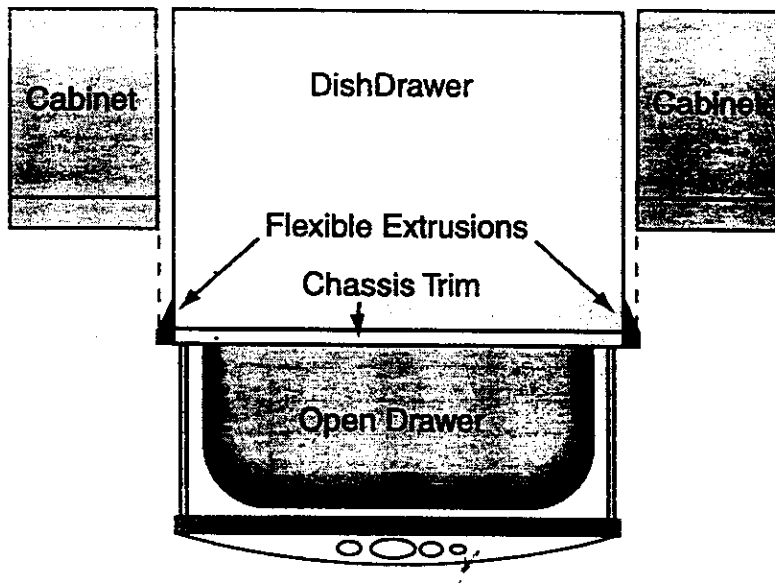

1. Open the drawers, exposing the chassis trim.
2. Remove backing from adhesive tape on Flexible Extrusion.
3. Apply as per drawings, ensuring the curved edge of the Flexible Extrusion fits around the corner of the chassis trim.
4. When checking final fit, ensure DishDrawer is centered and there are even tolerances between DishDrawer and cavity.

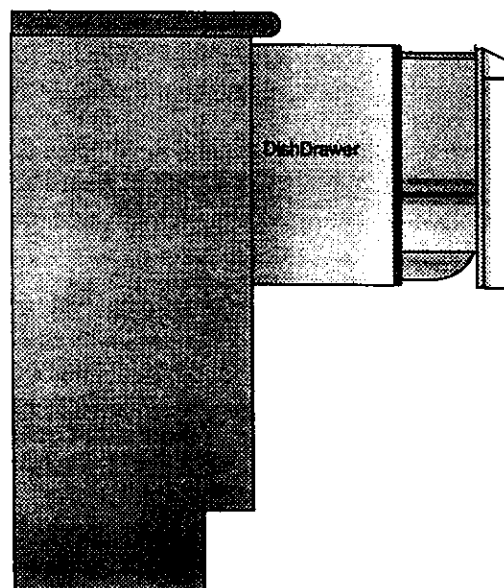

SECTION 4

INSERTING SINGLE DISHDRAWER INTO CAVITY

! WARNING
DO NOT push against the middle of the drawer.

! IMPORTANT
Make sure the inlet and drain hose and main flex are not restricted or damaged by carefully pulling them through the Services Hole as the DishDrawer is being pushed back into the cavity.

! WARNING
The DishDrawer should not support any part of the kitchen cabinetry.

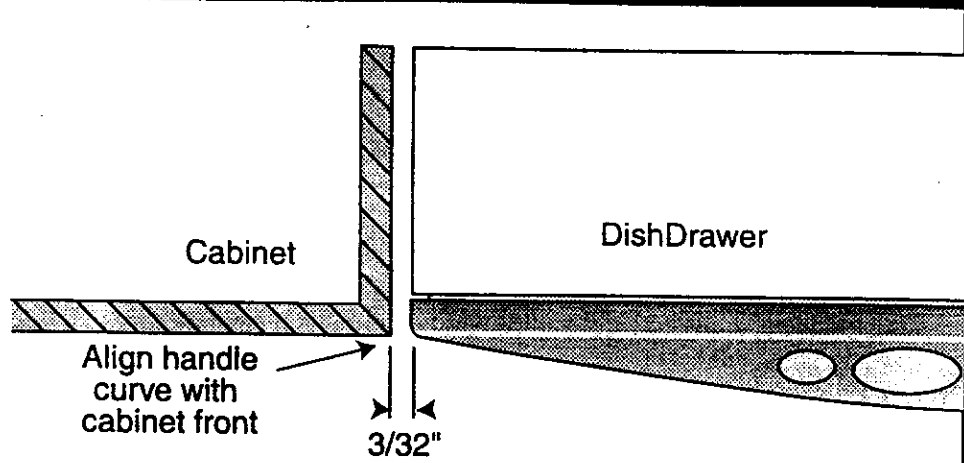

1. Position product to suit joinery ensuring hoses are not kinked or cut.

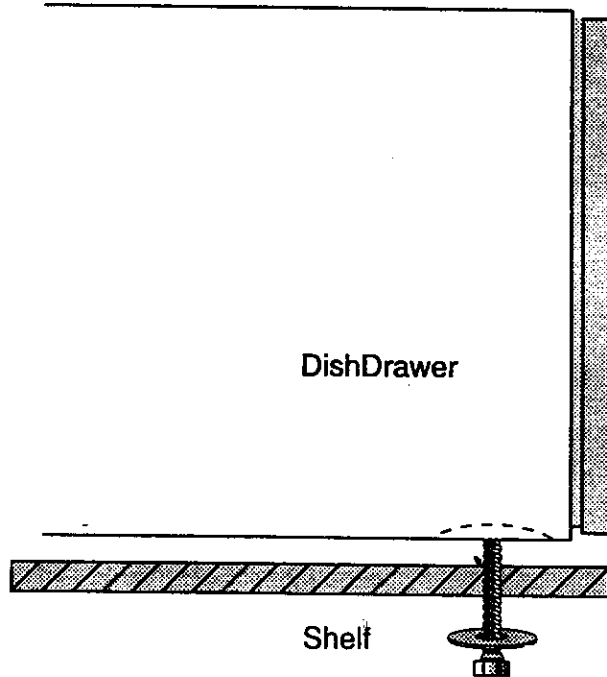

2. Insert M8 bolts and washers through holes in shelf.

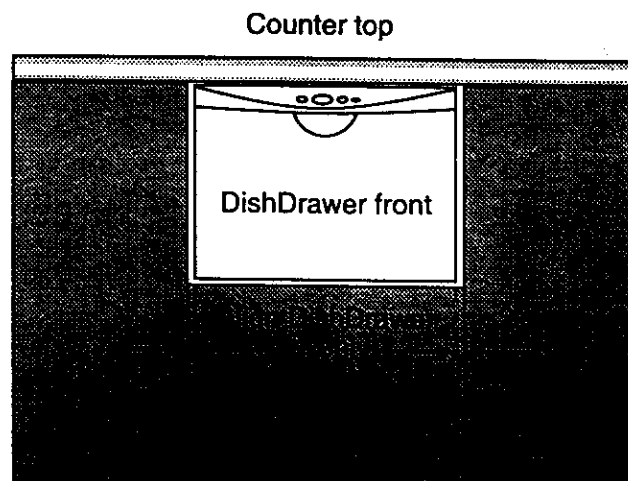

3. Ensure product is correctly positioned and aligned before tightening.

4. For installations where there is a lower drawer, insert the foam seal provided as per Step 5.4 - Option 1.

Refer to Step 8.1 - Installation Wet Test.

INFORMATION FOR CABINET MAKER FOR INTEGRATED DISHDRAWER

SECTION 5

STEP 5.1 POINTS TO CONSIDER

1. Customer / Architect to Specify

- Control Badge position.
- Badge can be located anywhere within the Mounting Zone shown. Handle position will need to be taken into account.
- When mounting the handle ensure fastenings do not protrude beyond the back surface of the Drawer Front.

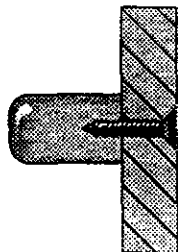

- Drawer Front Panel material and finish measurements are based on $\frac{3}{4}$ " material and cannot be less than $\frac{5}{8}$ " thick.

2. Work Required

- Manufacture of Top Drawer Front Panel.
- Supply and inserting of four bracket screw inserts in Drawer Front Panel.
- Cutting of oval hole for Control Badge in each Drawer Front Panel.



IMPORTANT

Drawer Front material must be suitable for damp conditions or adequately sealed to withstand moisture.

STEP 5.2 INTEGRATED OVERVIEW

! IMPORTANT

Recommended Drawer Front thickness for Integrated product is $\frac{3}{8}$ " to $\frac{3}{4}$ ".

! IMPORTANT

A minimum clearance of $\frac{3}{32}$ " must be maintained between the Drawer Front and existing cabinetry, except between the underside of the Drawer Front and the shelf, where a $\frac{1}{4}$ " clearance is needed for product venting.

! IMPORTANT

Dimensions for W1 and H1 are required prior to making the Drawer Front.

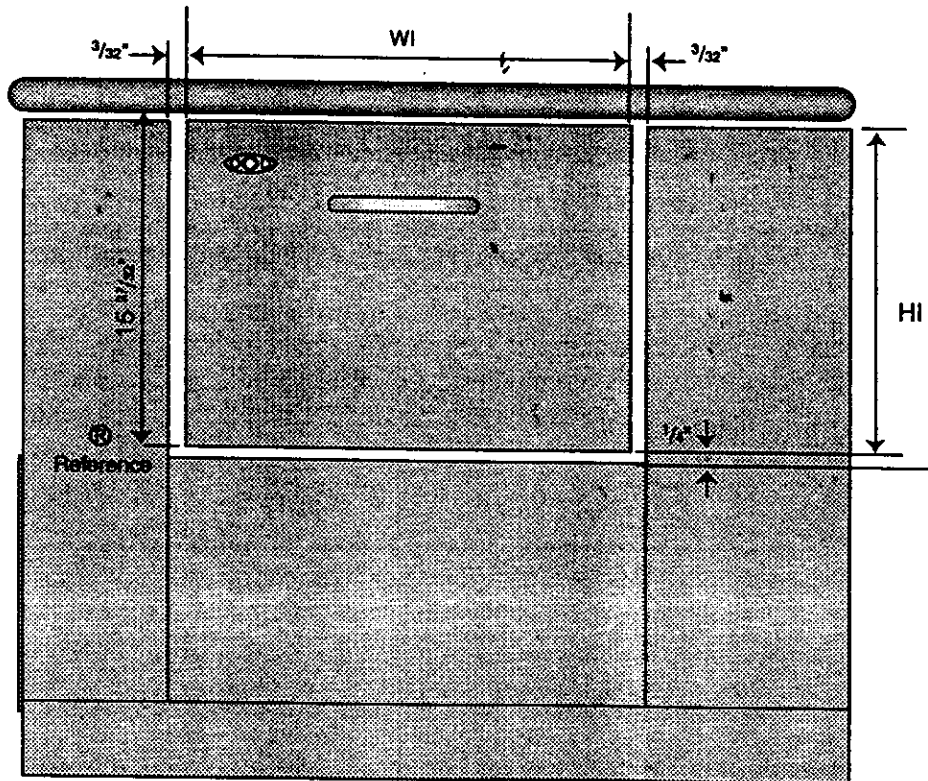
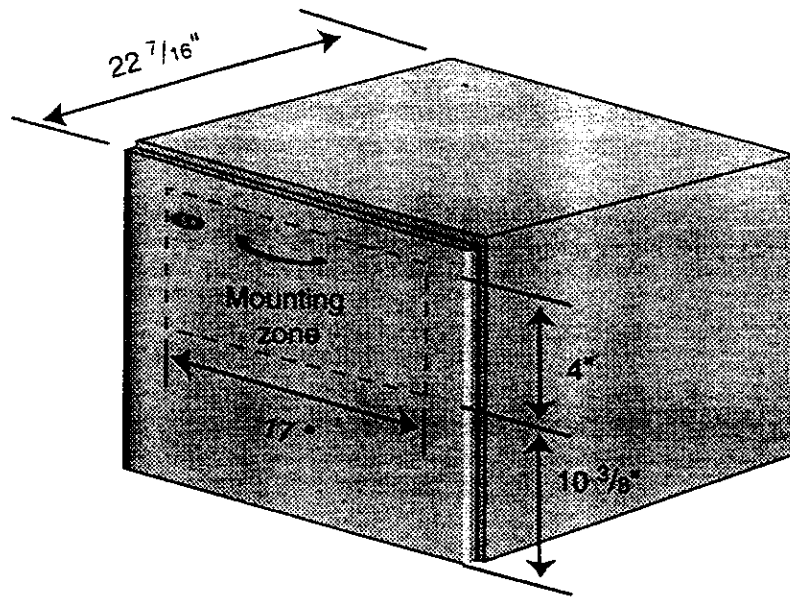

STEP 3.3 INTEGRATED DRAWER FRONT DIMENSIONS

1. Width Measurements (W1)

Measure the width of the cavity at the top and the bottom, using the smaller of the measurements, subtract $\frac{1}{16}$ " ($\frac{3}{32}$ " each side) clearance. This is the width dimension for the Drawer Front.

Note: Allowances must be made if Drawer Fronts are to overlap cabinetry.

2. Drawer Front Height (H1)

Dimensions for the height of the Drawer Front Panel can be obtained by measuring up from the shelf to the height of the adjoining door or cupboard front. Subtract $\frac{1}{4}$ " to give Drawer Front height. The minimum height of the Drawer Front is $15\frac{11}{32}$ "

3. Badge Cutout Dimensions

Cut out Badge Mounting Hole in the chosen position (see Mounting Zone) using the Template diagram below.

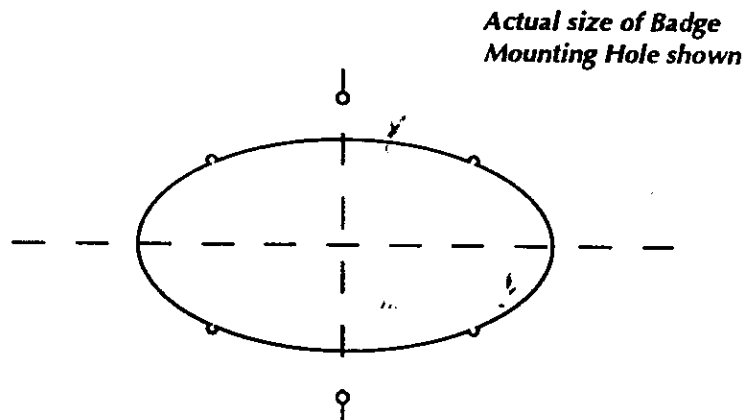

4. Drawer Front Mounting Bracket Nut Holes

Using a $\frac{11}{32}$ " diameter drill bit, drill out the four screw holes in each door panel to a depth of $\frac{9}{16}$ ". Remove burrs.

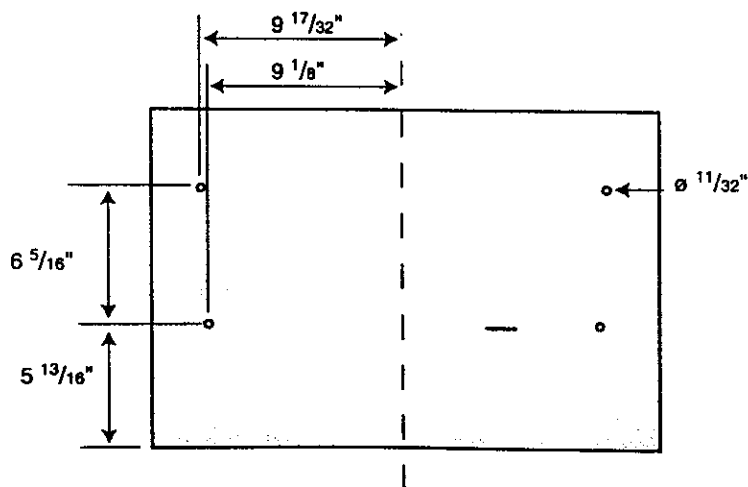

! IMPORTANT

All marking out to be done on the back surface of the Drawer Front.

! CAUTION

Ensure the drill does not damage the face of the Drawer Front.

! IMPORTANT

Accuracy is essential when cutting the Badge Mounting Hole to ensure a neat fit.

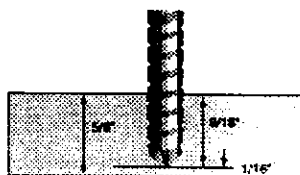

! WARNING

Use of a depth gauge is recommended when drilling out holes for Drawer Front Mounting Panel.



IMPORTANT

A minimum clearance of 1/4" is required between the underside of the Drawer Front and cabinetry below for product venting.

STEP 5.4 SHELF & INTEGRATED DRAWER FRONT PREPARATION

Option 1 and Option 2 show two different styles of cabinetry.

Option 1 shows how to seal cabinetry below the DishDrawer by using a foam seal provided in the accessories.

Option 2 shows cabinetry that does not require sealing.

Option 1

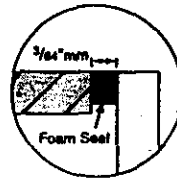
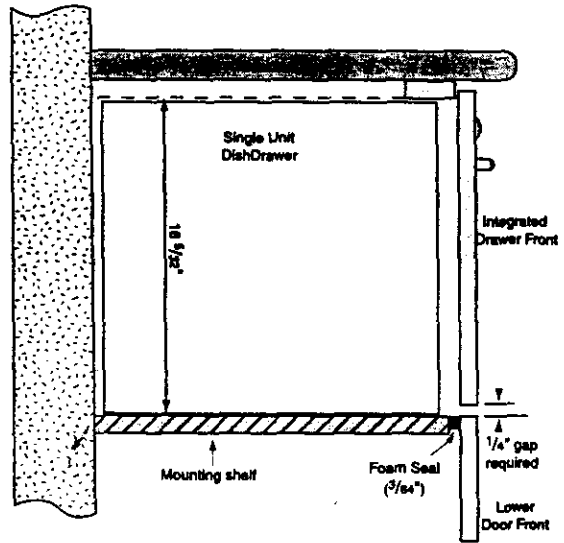

Option 2

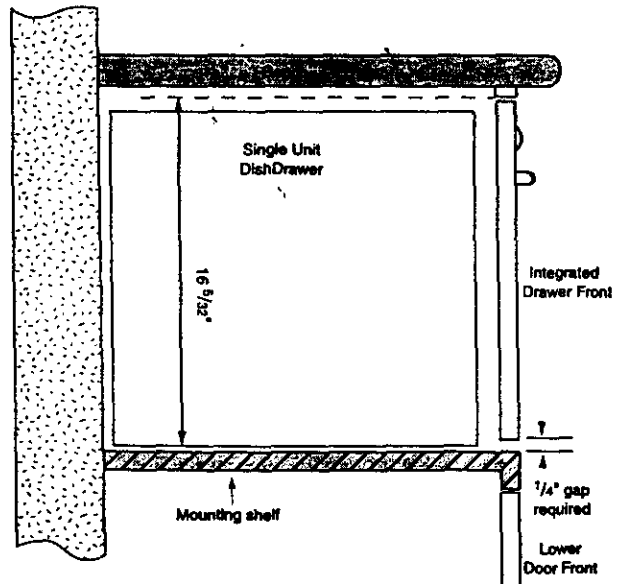

INTEGRATED DRAWER FRONT INSTALLATION SECTION 6

STEP 6.1 CHANGING THE INTEGRATED BADGE ENCLOSURE

There are several different colored Integrated badges to choose from. They include black, chrome, satin & brass. Two color options are provided with your machine, other options are available from your local Dealer.

There are five parts to the Integrated Badge Assembly. They are as follows:

1. Integrated Badge
2. Button Badge
3. Light Pipe
4. Electronics Board
5. Badge Cover

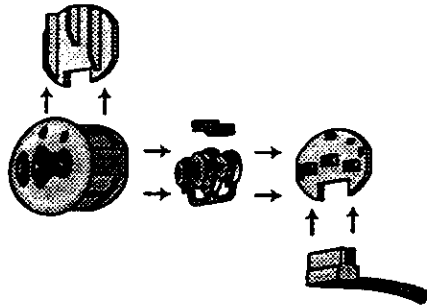

STEP 6.2 DISASSEMBLING THE INTEGRATED BADGE ASSEMBLY

1. Remove Badge Cover from the Integrated Badge.
At the back of the Integrated Badge, slide the Badge Cover away from the wire terminals.
2. Remove Electronics Board.
Gently hold the wires to remove the Electronics Board. Care should be taken not to handle the front or back of the Electronics Board or touch inside the wire terminals.
3. Remove the Light Pipe.
Gently tap the Integrated Badge upside down on a hard surface until the Light Pipe comes away or insert a pen or pencil into the front side of the Integrated Badge to either one of the two small holes.
4. Once you have removed the Electronics Board, Badge Cover and Light Pipe, you can change the color of the Integrated Badge.

STEP 6.3 ASSEMBLING THE INTEGRATED BADGE

1. Insert the Button Badge into the back of the Integrated Badge. Do not break any of the buttons away from the Connection Runner.
2. Insert the Light Pipe into the Integrated Badge.
Insert the Light Pipe with the circular ends into the small holes.
3. Insert the Electronics Board with care, behind the Button Badge.
When installing the Electronics Board, handle only the wires and do not touch the face or back of the Electronics Board or inside the wire terminals.
4. Slide the Badge Cover into the slot on top of the Integrated Badge.

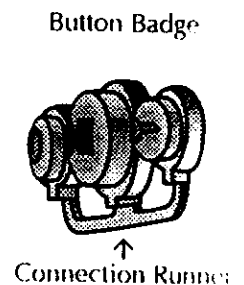



WARNING

Care should be taken in the following steps.



CAUTION

Take care not to damage front surface of panel.

Ensure all cuts are straight and care is taken to avoid damage to the Drawer Front.



CAUTION

Overtightening will damage the Drawer Front.

STEP 6.4 FITTING THE BADGE, HANDLE & MOUNTING PANEL TO THE DRAWER FRONT

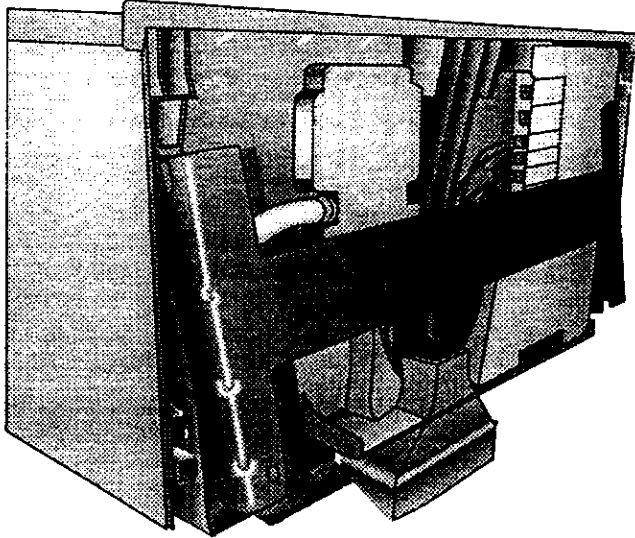

1.
Remove Drawer Front Mounting Panel by withdrawing pins from sides of drawers using long nosed pliers.

2.
Slide Mounting Panel off in a downwards and outwards motion. Remove the badge leads from the Electronics Board before completely removing the Mounting Panel.

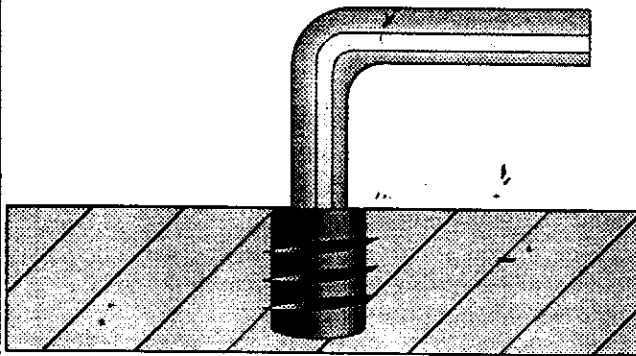

3.
Using an Allen Key, screw in Mounting Bracket Nuts. Remove Burrs. Screw in flush with back surface.

4.
Fit the Door Mounting Panels using the screws supplied.

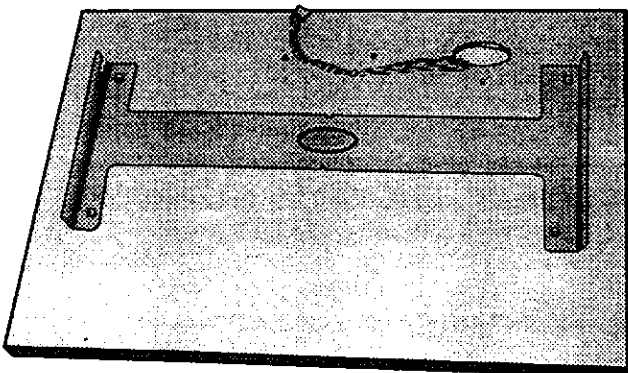

5.
Feed wires through to the back and press badge into hole, if needed adhere badge to Drawer Front with a glue or silicon sealant.

6.
Fit the customer supplied handle. Refer to *Step 6.1 - Points to Consider*.

STEP 6.5 FITTING THE DRAWER FRONT TO THE DISHDRAWER

1.

Fit seal to Drawer.

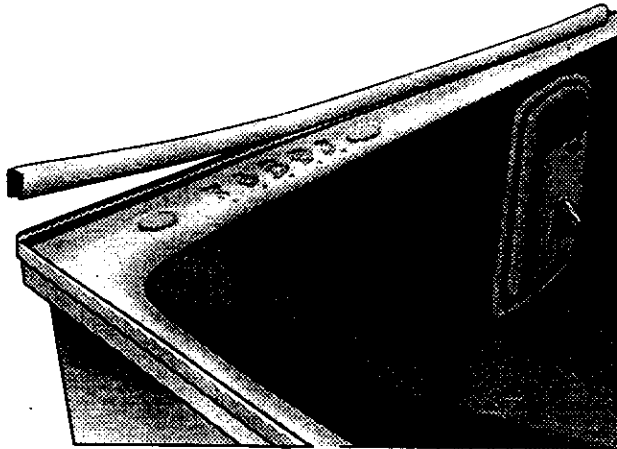

2.

Plug the grounding wire onto the panel.

Connect badge wires to integrated badge port on Electronics Board.

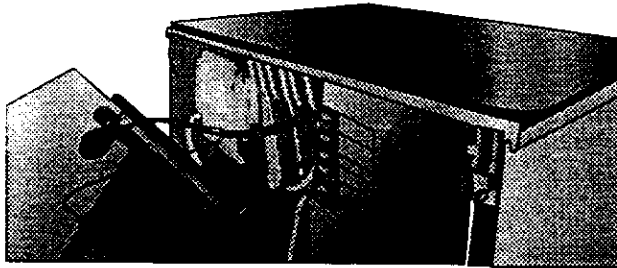

3.

Fit Drawer Front by sliding in an upwards and inwards motion.

4.

Ensure the slide hooks (on slide) are as far forward as possible as shown, then insert pins to lock in place, ensuring that the rib on the pin is vertical.

Check fit of the Drawer Front and adjust if required.

CORRECT

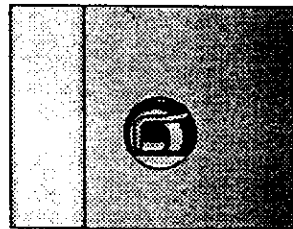

INCORRECT

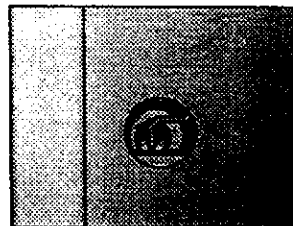

TIP

Use a small amount of liquid soap along the lip of the seal to aid the Drawer Front to slide easily against the seal.



CAUTION

The rubber seal between the Drawer and Drawer Front must be kept in place.



WARNING

The Electronics Board is an electrostatic sensitive device. Ensure you are adequately grounded when connecting or disconnecting the badge by wearing a grounding strap or by grounding yourself.



WARNING

Ensure the product is not plugged in.

Counter top

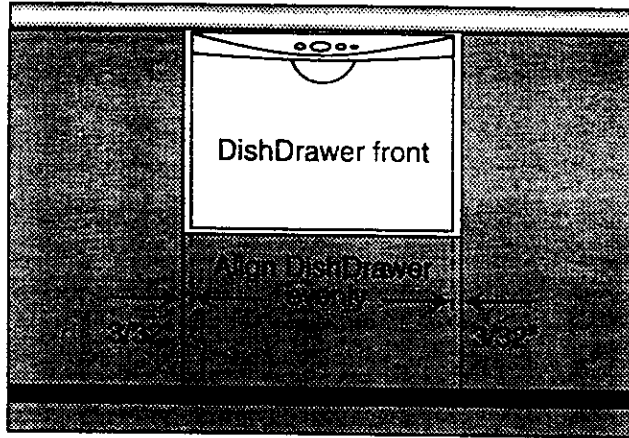

1.

Check final fit of DishDrawer in cavity.

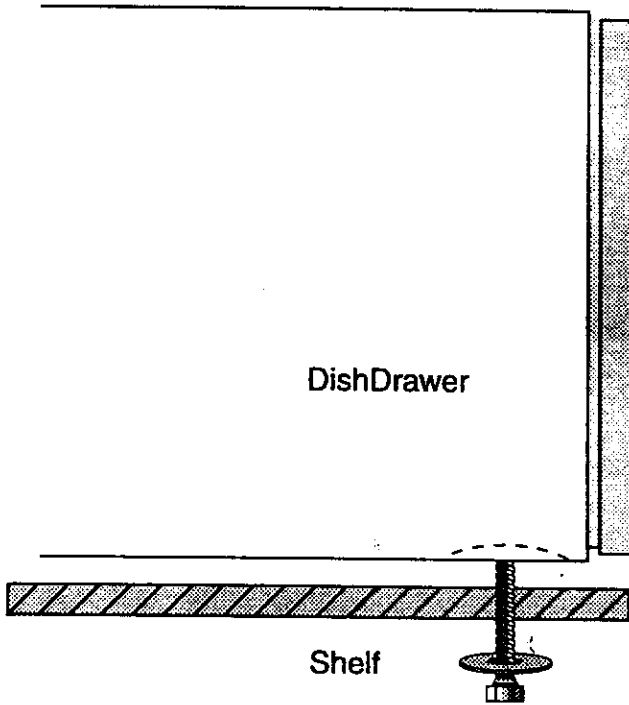

2.

Tighten M8 bolts.



FINAL CHECKS

SECTION 8

STEP 8.1 INSTALLATION WET TEST

1. Ensure product is level, securely fastened to the floor and opens and closes freely.
2. Ensure inlet hose to faucet connection is tightened to specification.
3. Ensure any knockouts or plugs in drain connection have been drilled out and drain connection made to specification.
4. Plug in and turn ON the power and water supply. The DishDrawer should "beep" and light up.
5. Open the drawers of the DishDrawer and check operation of Secondary Control Panel and check sprayarm(s) are in place and free to rotate.
6. Select Rinse program on the Secondary Control Panel and close the drawers.
7. Start the Program by pressing the Start/Pause button.
8. After the program has finished, check underneath the DishDrawer for water leakage. Ensure machine has run and drained correctly.
9. Check water supply and drainage connection for leakage.
10. Repeat for each Drawer.

STEP 8.2 TROUBLESHOOTING

1. Water underneath DishDrawer, check the hose connections and hose for leaks.
 2. Water around water supply and drainage connections - check connections, existing plumbing and hoses for leaks.
 3. Excessive water remaining above the filter plate, after the rinse cycle, check for kinked drain hoses or blocked waste connection.
 4. No water supply, check water is on and there is water pressure.
 5. If a fault occurs, consult the Problem Solver Section of the Use & Care Manual.
 6. If unable to resolve, contact Customer Care Center.
-  Ensure Power is connected and is switched ON.
-  Ensure the water supply is connected and ON.

LEAVE **ALL** LITERATURE WITH THE CUSTOMER.

