

Owner's Manual

CRAFTSMAN

24 in. 2 speed SCROLL SAW

Model No.
315.216230

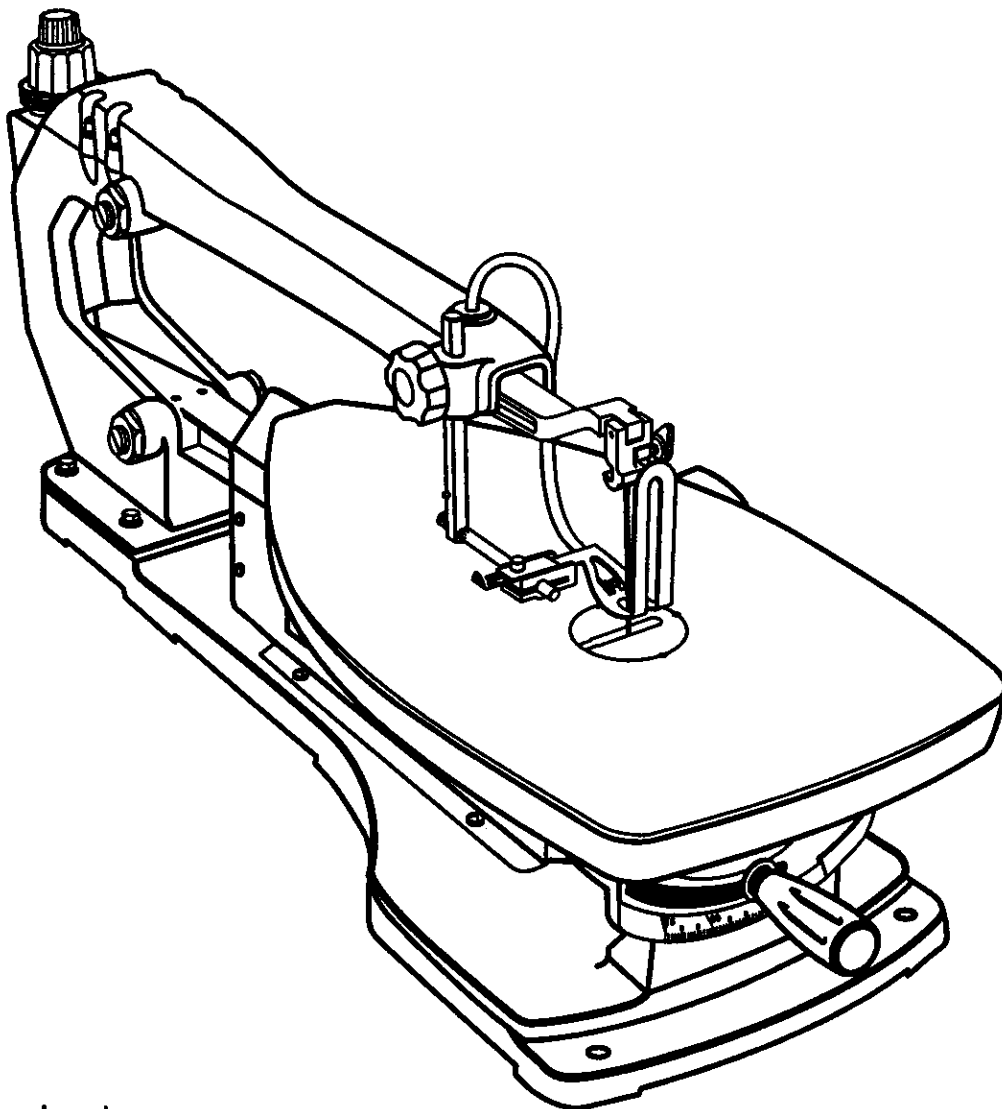

Save this manual for
future reference.

▲ CAUTION: Read and
follow all Safety Rules and
Operating Instructions before
first use of this product.

Customer Help Line
1-800-932-3188

Sears, Roebuck and Co., Hoffman Estates, IL 60179 USA
Visit the Craftsman web page: www.sears.com/craftsman

972000-527
11-98

- Safety
- Features
- Adjustments
- Operation
- Maintenance
- Parts List



NRTL/C

TABLE OF CONTENTS

■ Table of Contents	2
■ Warranty and Introduction	2
■ Rules For Safe Operation	3 - 5
■ Electrical	6
■ Glossary and Product Specifications	7
■ Unpacking and Tools Needed	8
■ Labels	8 - 9
■ Features	10-11
■ Assembly	11-12
■ Adjustments	12-15
■ Operation	16-18
■ Maintenance	19
■ Troubleshooting	20
■ Exploded View and Repair Parts List	22-27
■ Parts Ordering / Service	28

WARRANTY

FULL ONE YEAR WARRANTY ON CRAFTSMAN SCROLL SAW

If this **CRAFTSMAN** Scroll Saw fails due to a defect in material or workmanship within one year from the date of purchase, Sears will repair it, free of charge.

Contact a Sears Service Center for repair.

If this product is used for commercial or rental purposes, this warranty applies only for 90 days from the date of purchase.

This warranty gives you specific legal rights, and you may also have other rights which vary from state to state.

Sears, Roebuck and Co., Dept. 817WA, Hoffman Estates, IL 60179

INTRODUCTION

Your saw has many features for making cutting operations more pleasant and enjoyable. Safety, performance and dependability have been given top priority in the design of this saw making it easy to maintain and operate.

CAUTION: Carefully read through this entire owner's manual before using your new saw. Pay close attention to the Rules For Safe Operation, and all Safety Alert Symbols including Danger, Warning and Caution. If you use your saw properly and only for what it is intended, you will enjoy years of safe, reliable service.

! Look for this symbol to point out important safety precautions. It means attention!!! Your safety is involved.

! WARNING:



The operation of any power tool can result in foreign objects being thrown into your eyes, which can result in severe eye damage. Before beginning power tool operation, always wear safety goggles or safety glasses with side shields and a full face shield when needed. We recommend Wide Vision Safety Mask for use over eyeglasses or standard safety glasses with side shields, available at Sears Retail Stores.

RULES FOR SAFE OPERATION

The purpose of safety symbols is to attract your attention to possible dangers. The safety symbols, and the explanations with them, deserve your careful attention and understanding. The safety warnings do not by themselves eliminate any danger. The instructions or warnings they give are not substitutes for proper accident prevention measures.

SYMBOL MEANING



SAFETY ALERT SYMBOL:

Indicates danger, warning or caution. May be used in conjunction with other symbols or pictographs.



DANGER: Failure to obey a safety warning will result in serious injury to yourself or to others. Always follow the safety precautions to reduce the risk of fire, electric shock and personal injury.



WARNING: Failure to obey a safety warning can result in serious injury to yourself or to others. Always follow the safety precautions to reduce the risk of fire, electric shock and personal injury.



CAUTION: Failure to obey a safety warning may result in property damage or personal injury to yourself or to others. Always follow the safety precautions to reduce the risk of fire, electric shock and personal injury.

Note: Advises you of information or instructions vital to the operation or maintenance of the equipment.

IMPORTANT

Servicing requires extreme care and knowledge of the system and should be performed only by a qualified service technician. For service we suggest you return the tool to your nearest Sears store for repair. Always use original factory replacement parts when servicing.



WARNING: Do not attempt to operate this tool until you have read thoroughly and understand completely all instructions, safety rules, etc. contained in this manual. Failure to comply can result in accidents involving fire, electric shock, or serious personal injury. Save owner's manual and review frequently for continuing safe operation, and instructing others who may use this tool.



WARNING: Do not connect your scroll saw to a power source until you have assembled and adjusted the saw as described in this manual and have read and understood all precautions and operating instructions in the manual and printed on the tool.

READ ALL INSTRUCTIONS

- **KNOW YOUR POWER TOOL.** Read the owner's manual carefully. Learn the saw's applications and limitations as well as the specific potential hazards related to this tool.
- **GUARD AGAINST ELECTRICAL SHOCK BY PREVENTING BODY CONTACT WITH GROUNDED SURFACES.** For example; pipes, radiators, ranges, refrigerator enclosures.
- **KEEP GUARDS IN PLACE** and in good working order.

- **REMOVE ADJUSTING KEYS AND WRENCHES.** Get in the habit of checking to see that hex keys and adjusting wrenches are removed from tool before turning on the saw.
- **KEEP THE WORK AREA CLEAN.** Cluttered work areas and work benches invite accidents. **DO NOT** leave tools or pieces of wood on the saw while it is in operation.
- **DO NOT USE IN DANGEROUS ENVIRONMENTS.** Do not use power tools near gasoline or other flammable liquids, in damp or wet locations, or expose them to rain. Keep the work area well lit.
- **KEEP CHILDREN AND VISITORS AWAY.** All visitors should wear safety glasses and be kept a safe distance from work area. Do not let visitors contact tool or extension cord while operating.
- **MAKE WORKSHOP CHILD-PROOF** with padlocks and master switches or by removing starter keys.
- **DO NOT FORCE THE TOOL.** It will do the job better and safer at the rate for which it was designed.
- **USE THE RIGHT TOOL.** Do not force the tool or attachment to do a job it was not designed for. Don't use it for a purpose not intended.

RULES FOR SAFE OPERATION (Continued)

- **USE THE PROPER EXTENSION CORD.** Make sure your extension cord is in good condition. When using an extension cord, be sure to use one heavy enough to carry the current your product will draw. An undersized cord will cause a drop in line voltage resulting in loss of power and overheating. A wire gage size (A.W.G.) of at least 18 is recommended for an extension cord 25 feet or less in length. If in doubt, use the next heavier gage. The smaller the gage number, the heavier the cord.
 - **INSPECT EXTENSION CORDS PERIODICALLY** and replace if damaged.
 - **DRESS PROPERLY.** Do not wear loose clothing, gloves, neckties, rings, bracelets, or other jewelry. They can get caught and draw you into moving parts. Rubber gloves and nonslip footwear are recommended. Also wear protective hair covering to contain long hair.
 - **ALWAYS WEAR SAFETY GLASSES WITH SIDE SHIELDS.** Everyday eyeglasses have only impact-resistant lenses; they are **NOT** safety glasses.
 - **PROTECT YOUR LUNGS.** Wear a face or dust mask if the cutting operation is dusty.
 - **PROTECT YOUR HEARING.** Wear hearing protection during extended periods of operation.
 - **SECURE WORK.** Use clamps or a vise to hold work when practical. It's safer than using your hand and it frees both hands to operate tool.
 - **DO NOT OVERREACH.** Keep proper footing and balance at all times.
 - **MAINTAIN TOOLS WITH CARE.** Keep tools sharp and clean for better and safer performance. Follow instructions for lubricating and changing accessories.
 - **DISCONNECT ALL TOOLS.** When not in use, before servicing, or when changing attachments, blades, bits, cutters, etc., all tools should be disconnected from power supply.
 - **AVOID ACCIDENTAL STARTING.** Be sure switch is off when plugging in.
 - **USE RECOMMENDED ACCESSORIES.** The use of improper accessories may cause risk of injury.
 - **NEVER STAND ON TOOL.** Serious injury could occur if the tool is tipped or if the blade is unintentionally contacted.
 - **CHECK DAMAGED PARTS.** Before further use of the tool, a guard or other part that is damaged should be carefully checked to determine that it will operate properly and perform its intended function. Check for alignment of moving parts, binding of moving parts, breakage of parts, saw stability, mounting and any other conditions that may affect its operation. A guard or other part that is damaged must be properly repaired or replaced by a qualified service technician at a Sears store to avoid risk of personal injury.
 - **DIRECTION OF FEED.** Feed work into a blade or cutter against the movement of the blade or cutter only.
 - **NEVER LEAVE TOOL RUNNING UNATTENDED. TURN THE POWER OFF.** Do not leave tool until it comes to a complete stop.
 - **USE ONLY CORRECT BLADES.** Use the right blade size, style and cutting speed for the material and the type of cut. Blade teeth should point down toward the table. Sharp blades minimize stalling and kickback. Correctly adjust blade tension.
 - **TO PROTECT THE OPERATOR** and minimize blade breakage, **ALWAYS** adjust the hold down foot until it rests on top of the workpiece to prevent the workpiece from lifting while cutting, but not so much that the workpiece drags. Never operate the saw with any guard or cover removed. Make sure all guards are operating properly before each use.
 - **KEEP HANDS AWAY FROM CUTTING AREA.** Do not hand hold pieces so small that your fingers go under the blade guard. Never reach underneath work or behind, under, or within three inches of the blade and its cutting path with your hands and fingers for any reason. Do not attempt to remove cut material when blade is moving.
-  **WARNING:** Blades coast after turn off.
- **AVOID PINCHING THE BLADE.** Be cautious when cutting off material which is irregular in cross section. For example, molding must lay flat on the table and not be permitted to rock.
 - **DO NOT ABUSE CORD.** Never yank cord to disconnect it from receptacle. Keep cord from heat, oil, and sharp edges.
 - **INSPECT TOOL CORDS PERIODICALLY** and if damaged, have repaired by a qualified service technician at a Sears store. Stay constantly aware of cord location and keep it well away from the rotating blade.
 - **DO NOT USE TOOL IF SWITCH DOES NOT TURN IT ON AND OFF.** Have defective switches replaced by a qualified service technician at a Sears store.

RULES FOR SAFE OPERATION (Continued)

- **KEEP TOOL DRY, CLEAN, AND FREE FROM OIL AND GREASE.** Always use a clean cloth when cleaning. Never use brake fluids, gasoline, petroleum-based products, or any solvents to clean tool.
- **A LARGE PIECE OF MATERIAL SHOULD BE SUPPORTED** while cutting. To minimize risk of blade pinching and kickback, always support long workpieces. Saw may slip, walk or slide while cutting long or heavy boards.
- **BEFORE MAKING A CUT, BE SURE ALL ADJUSTMENTS ARE SECURE.**
- **BEFORE CHANGING THE SETUP, REMOVING COVERS, GUARDS OR BLADE, UNPLUG THE SAW.**
- **DO NOT FEED THE MATERIAL TOO QUICKLY** while cutting. Do not force the workpiece against the blade.
- **NEVER CUT MORE THAN ONE WORKPIECE AT A TIME.** If making a stacked cut, all of the pieces must be secured to each other with masking tape or double stick tape to make one workpiece. Do not put more than one workpiece on the saw table at a time. Always hold the work firmly against the table. See page 17.
- **AVOID CUTTING NAILS.** Inspect for and remove all nails from lumber before cutting.
- **NEVER PERFORM LAYOUT, ASSEMBLY, OR SETUP WORK ON THE TABLE** while the cutting tool is operating.
- **NEVER TOUCH BLADE** or other moving parts during use.
- **NEVER START A TOOL WHEN THE BLADE IS IN CONTACT WITH THE WORKPIECE.** Clear the table of debris before turning your scroll saw on.
- **ALLOW THE MOTOR TO COME UP TO FULL SPEED** before starting a cut.
- **FIRMLY CLAMP OR BOLT** your scroll saw to a firm, level workbench or table. The most comfortable saw table height is at approximately hip height.
- **AVOID AWKWARD OPERATIONS AND HAND POSITIONS** where a sudden slip could cause your hand to move into the blade. **ALWAYS** make sure you have good balance. Do not cut pieces of material that are too small to hold comfortably in your hand.
- **REPLACEMENT PARTS.** All repairs, whether electrical or mechanical, should be made by qualified service technician at a Sears store or repair center.
- ▲ **WARNING:** When servicing use only identical Craftsman replacement parts. Use of any other parts may create a hazard or cause product damage.
- **NEVER USE IN AN EXPLOSIVE ATMOSPHERE.** Normal sparking of the motor could ignite fumes.
- **DO NOT OPERATE THIS TOOL WHILE UNDER THE INFLUENCE OF DRUGS, ALCOHOL, OR ANY MEDICATION.**
- **STAY ALERT AND EXERCISE CONTROL.** Watch what you are doing and use common sense. **Do not operate tool when you are tired. Do not rush.**
- **MAKE SURE THE WORK AREA HAS AMPLE LIGHTING** to see the work and that no obstructions will interfere with safe operation **BEFORE** performing any work using your saw.
- **ALWAYS TURN OFF SAW** before disconnecting it, to avoid accidental starting when reconnecting to power supply. **NEVER** leave the scroll saw unattended while connected to a power source.
- ▲ **WARNING:** Do not allow familiarity with your saw make you careless. Remember that a careless fraction of a second is sufficient to inflict severe injury.
- **SAVE THESE INSTRUCTIONS.** Refer to them frequently and use to instruct other users. If you loan someone this tool, loan them these instructions also.

SAVE THESE INSTRUCTIONS

EXTENSION CORDS

Use only 3-wire extension cords that have 3-prong grounding plugs and 3-pole receptacles that accept the tool's plug. When using a power tool at a considerable distance from the power source, use an extension cord heavy enough to carry the current that the tool will draw. An undersized extension cord will cause a drop in line voltage, resulting in a loss of power and causing the motor to overheat. Use the chart provided below to determine the minimum wire size required in an extension cord. Only round jacketed cords listed by Underwriter's Laboratories (UL) should be used.

Length of Extension Cord	Wire Size (A.W.G.)
Up to 25 feet	18
26-100 feet	16

When working with the tool outdoors, use an extension cord that is designed for outside use. This is indicated by the letters **WA** on the cord's jacket.

Before using an extension cord, inspect it for loose or exposed wires and cut or worn insulation.

⚠ CAUTION: Keep the cord away from the cutting area and position the cord so that it will not be caught on lumber, tools, or other objects during cutting.

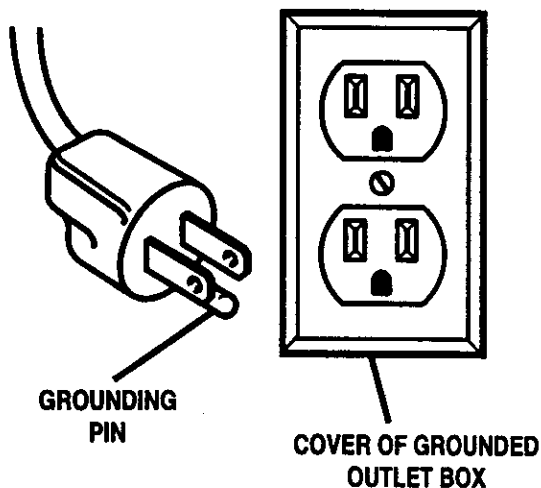

Fig. 1

ELECTRICAL CONNECTION

Your Sears Craftsman Scroll Saw is powered by a precision built electric motor. It should be connected to a **power supply that is 120 volts, 60 Hz, AC only (normal household current)**. Do not operate this tool on direct current (DC). A substantial voltage drop will cause a loss of power and the motor will overheat. If the saw does not operate when plugged into an outlet, double check the power supply.

GROUNDING INSTRUCTIONS

In the event of a malfunction or breakdown, grounding provides a path of least resistance for electric current to reduce the risk of electric shock. This tool is equipped with an electric cord having an equipment-grounding conductor and a grounding plug. The plug must be plugged into a matching outlet that is properly installed and grounded in accordance with all local codes and ordinances.

Do not modify the plug provided. If it will not fit the outlet, have the proper outlet installed by a qualified electrician. Improper connection of the equipment-grounding conductor can result in a risk of electric shock. The conductor with insulation having an outer surface that is green with or without yellow stripes is the equipment-grounding conductor. If repair or replacement of the electric cord or plug is necessary, do not connect the equipment-grounding conductor to a live terminal.

Check with a qualified electrician or service personnel if the grounding instructions are not completely understood, or if in doubt as to whether the tool is properly grounded.

Repair or replace a damaged or worn cord immediately.

This tool is intended for use on a circuit that has an outlet like the one shown in *Figure 1*. It also has a grounding pin like the one shown.

GLOSSARY OF TERMS FOR WOODWORKING

Bevel Cut

A cutting operation made with the table at any angle other than 90° to the blade.

Crosscut

A cutting or shaping operation made across the grain of the workpiece.

Compound Cut

A compound cut is a cut made using a miter angle and a bevel angle at the same time.

Freehand (for scroll saw)

Performing a cut without using a fixture to assure a straight cut (normally a curved or irregular shape).

Gum

A sticky, sap based residue from wood products.

Kerf

The material removed by the blade in a through cut or the slot produced by the blade in a nonthrough or partial cut.

Leading End

The end of the workpiece pushed into the cutting tool first.

Nonferrous Metal

Metal that does not contain iron; such as aluminum, brass, and copper.

Push Stick

A device used to feed the workpiece through the saw blade during narrow ripping type operations and helps keep the operator's hands well away from the blade.

Resin

A sticky, sap base substance that has hardened.

Ripping

A cutting operation along the length of the workpiece.

Saw Blade Path

The area directly in line — over, under, behind, or in front of the blade. As it applies to the workpiece, that area which will be, or has been, cut by the blade.

Set

The distance that the tip of the saw blade tooth is bent (or set) outward from the face of the blade.

SPM

Strokes per minute. Used in reference to blade movement.

Throw-Back

Throwing of a workpiece in a manner similar to a kickback, usually associated with a cause other than the kerf closing, being dropped into the blade, or being placed inadvertently in contact with the blade.

Through Sawing

Any cutting operation where the blade extends completely through the thickness of the workpiece.

Workpiece

The item on which the cutting operation is being done. The surfaces of a workpiece are commonly referred to as faces, ends, and edges.

Worktable

The surface on which the workpiece rests while performing a cutting or sanding operation.

PRODUCT SPECIFICATIONS

Throat	24 in.	Table Size	20-1/2 in. x 11 in.
Motor	120 V, 1.4 amp 60 HZ-AC only	Table Tilt	0° - 47° right
Drive	2 Speed 1725 Strokes per minute 825 Strokes per minute	Overall Dimensions	14 in. W 29-1/2 in. L 15 in. H
Blade Length	5 in. plain or pin	Net Weight	87 lb.

UNPACKING

⚠ WARNING: To prevent accidental starting or electrical shock that could cause possible serious personal injury, assemble all parts to your saw before connecting it to power supply. Saw should never be connected to power supply when you are assembling parts, making adjustments, lubricating, installing or removing blades, cleaning, or when not in use.

- This saw is very heavy. To avoid back injury, get help when lifting the saw.
- Carefully lift saw from the carton and place it on a level work surface.
- Remove pack of 4 extra blades and owner's manual from the carton.

⚠ WARNING: If any parts are missing, do not operate this tool until the missing parts are replaced. Failure to do so could result in possible serious personal injury.

- Do not discard the packing materials until you have carefully inspected the saw, identified all parts, and satisfactorily operated your new saw.

Note: If any parts are damaged or missing, do not attempt to plug in the power cord and turn the switch on until the damaged or missing parts are obtained and are installed correctly.

Your scroll saw table was covered with a lubricant and a cover at the factory to prevent rust. Remove the plastic cover and clean with a soft cloth and a small amount of mineral spirits, or rubbing alcohol. **Do not use acetone, gasoline, or lacquer thinner.** These are dangerous and may also damage plastic and rubber parts of your saw.

Your scroll saw comes completely assembled. A package of 4 extra blades and an owner's manual are included with your saw.

TOOLS NEEDED

The following tools (not included) are needed for adjustments and alignment:

- Small Combination Square
- Adjustable wrench
- Phillips Screwdriver

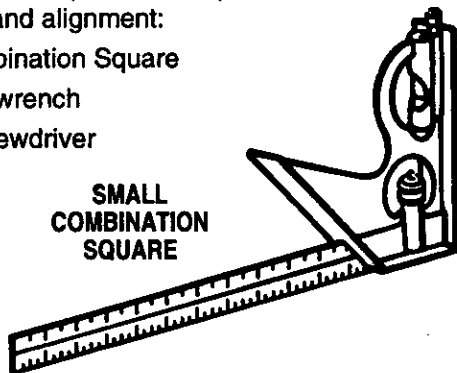

SMALL
COMBINATION
SQUARE

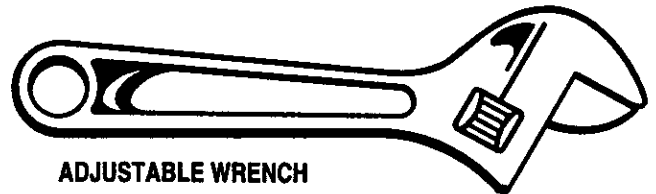

ADJUSTABLE WRENCH



PHILLIPS SCREWDRIVER

Fig. 2

LABELS

The following labels are on the scroll saw with locations indicated.

A.

CRAFTSMAN®

24-in. Scroll Saw

2-Speed

B.

▲ WARNING / ADVERTENCIA

- For your own safety, read instruction manual before operating saw.
- Wear eye protection.
- Install blade with teeth pointing down toward table.
- Keep fingers at safe distance from blade.
- Never leave Scroll Saw work area with power "ON".
- Adjust blade tension by hand (no tool) before turning "ON".
- Hold workpiece firmly against table.
- Make no adjustments until Scroll Saw has come to a complete stop.
- Do not remove cutoff pieces until blade has stopped.
- Maintain proper adjustment of blade tension.
- Do not expose to rain or use in damp locations.
- Para su propia seguridad, lea el manual del usuario antes de usar la sierra Ingletadora.

24 inch Scroll Saw
825 / 1725 SPM 1.4A 120 VOLTS 60 Hz AC ONLY

WARNING: USE IDENTICAL REPLACEMENT PARTS.

MODEL 315.216230 SER. NO.

MADE IN TAIWAN
SEARS, ROEBUCK AND CO.

 UNITED STATES PATENT OFFICE
STATIONARY TOOL

○ Customer Help Line 1-800-932-3188 ○

C.

**▲ WARNING
ADVERTENCIA**

Keep Hands Away From Blade.

Allow Tool To Stop Before Adjusting Blade.

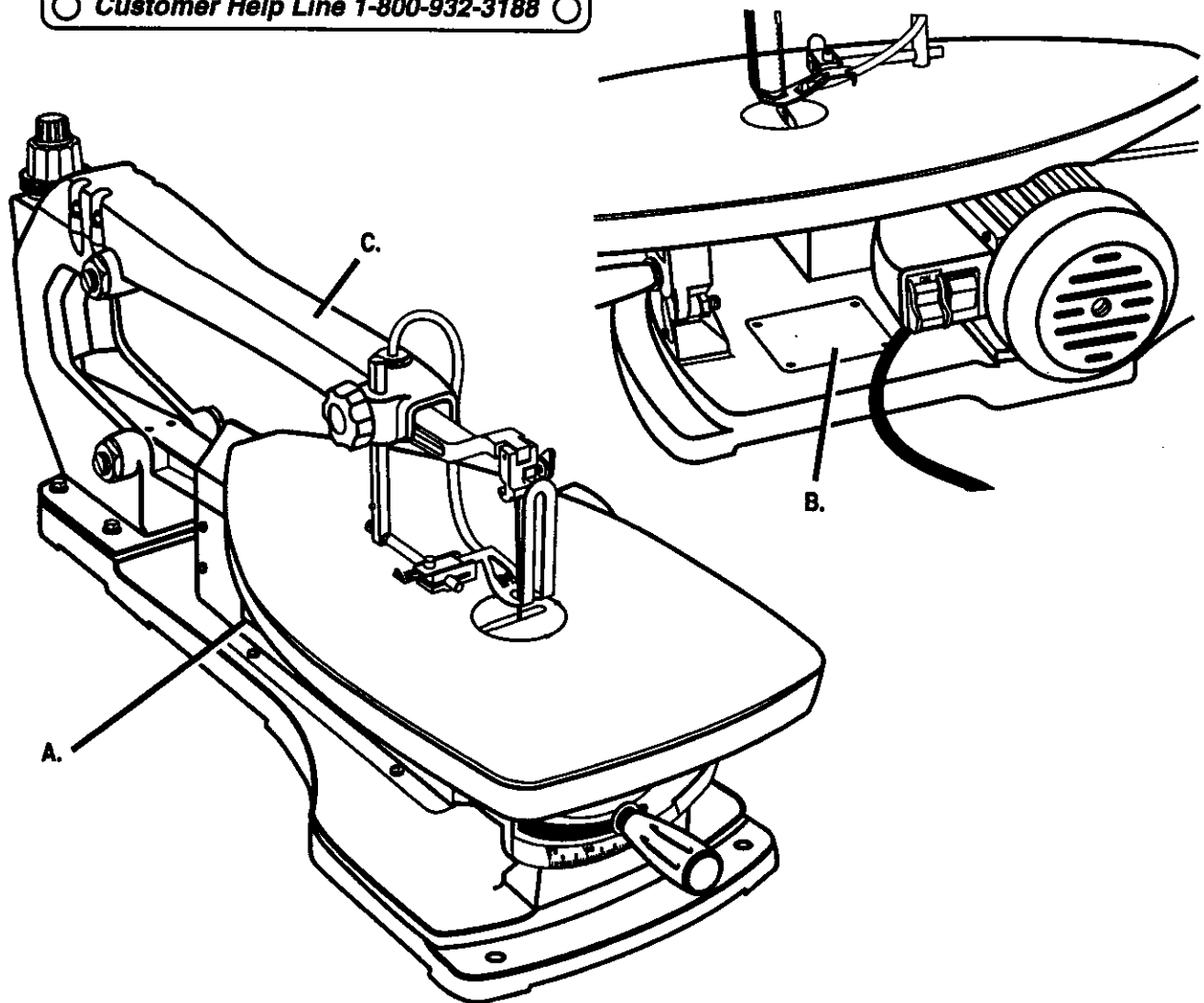



Fig. 3

FEATURES

This versatile heavy-duty scroll saw is great for making toys, puzzles, games, artwork, and jewelry. Because of its cutting capacity, it is a handy do-it-yourself tool. It cuts wood, wood composition products, plastic, and other fibrous material up to 2 inches thick.

KNOW YOUR SCROLL SAW

Before attempting to use your saw, familiarize yourself with all operating features and safety requirements of your Sears Craftsman scroll saw. See Figure 4.

ON/OFF SWITCH

The ON/OFF switch has a switch key locking feature. Remove the switch key and store it in another location to prevent unauthorized use by children and others.

TWO SPEED SWITCH

The speed switch, beside the ON/OFF switch, allows you to choose a high speed of approximately 1725 SPM (Strokes Per Minute) or a low speed of approximately 825 SPM.

TOOLLESS BLADE HOLDERS

Retain and position the blade without the use of additional tools. Use the knobs for plain end blades or use the designed slots for pin type blades.

BLADE TENSION KNOBS

Blade tension is controlled by a dual knob tension control system. The inner (smaller) knob, tension adjusting knob, is for making adjustments of the blade tension. The outer (larger) knob, quick release knob, is used to quickly set and release blade tension to facilitate blade changes.

HOLD DOWN FOOT/BLADE GUARD

The hold down foot should be lowered until it just rests on top of the workpiece to prevent the workpiece from lifting while cutting, but not so much that the workpiece drags. The vertical portion provides a blade guard to prevent accidental blade contact.

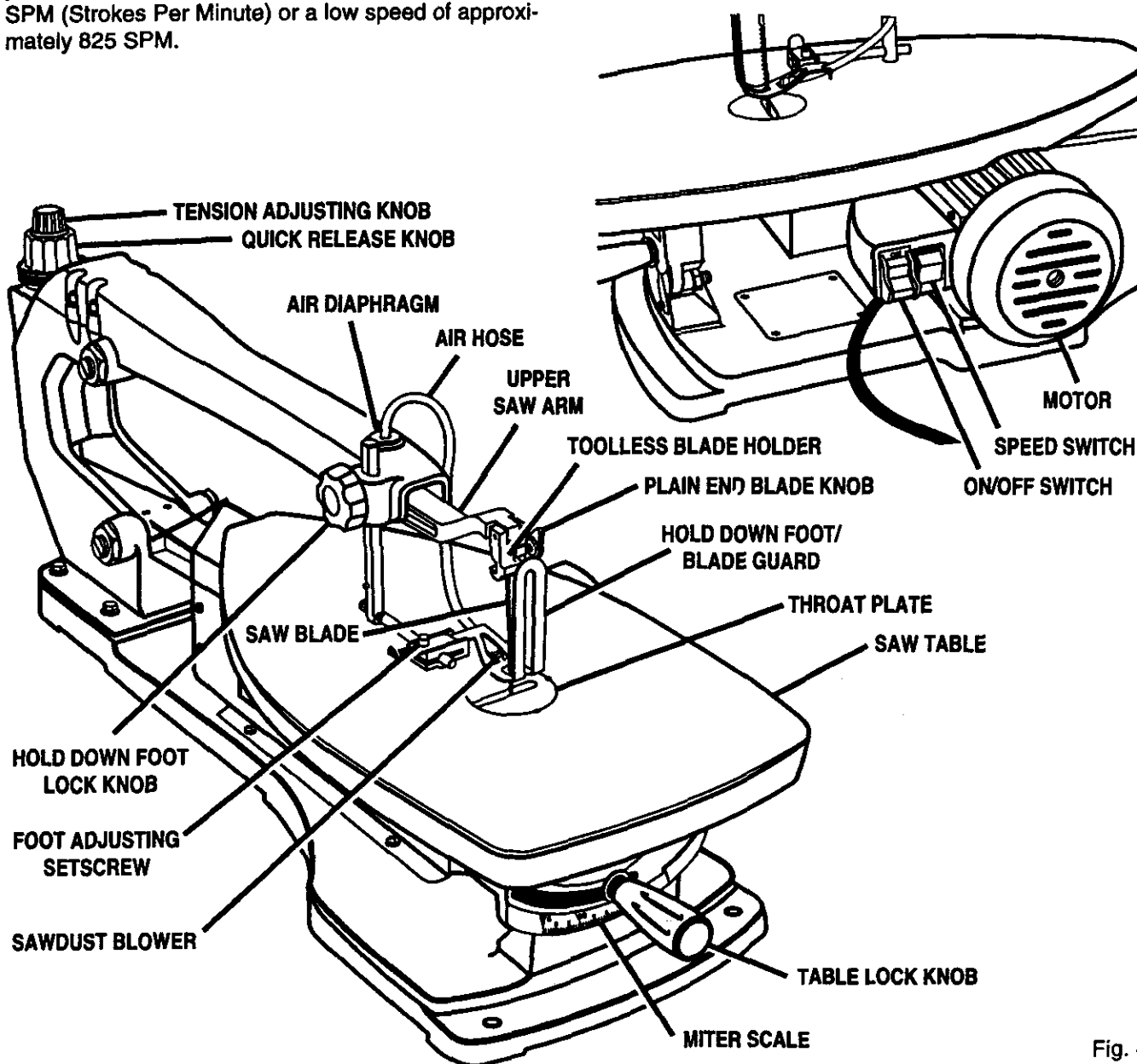

Fig. 4

FEATURES

HOLD DOWN FOOT LOCK KNOB

Allows you to raise or lower the hold down foot/blade guard and secure it at desired heights.

SAWDUST BLOWER

Keeps the line of cut on workpiece clean for more accurate scroll cuts.

SAW TABLE

Your scroll saw has an aluminum saw table that provides a working surface to support your workpiece.

TABLE LOCK KNOB

Allows you to tilt the table and lock it at the desired angle up to 47 degrees.

BEVEL SCALE

The bevel scale and indicator are located on the front of the saw for easy viewing. They show the angle of the table.

ZERO DEGREE STOP FOR TABLE

Allows easy return and fine adjustment of the zero degree relationship between the table and the blade.

ASSEMBLY

Your Craftsman 24 in. scroll saw was fully assembled at the factory. Before operating this tool, it is important to check all alignments and settings. Normal handling during shipment may have changed settings.

WARNING: To avoid serious personal injury from unexpected tool movement, always securely mount scroll saw to a workbench.

MOUNTING SCROLL SAW TO WORKBENCH

See Figure 5.

If the scroll saw is to be used in a permanent application, we recommend that you secure it in a permanent location such as a workbench. When mounting the saw to a workbench, holes should be drilled through the supporting surface of the workbench using dimensions illustrated.

- Each hole in the base of the saw should be bolted securely using 3/8 in. diameter machine bolts, lock washers, and hex nuts (not included). Bolt length should be 1-1/4 in. plus the thickness of the bench top.

- Locate and mark the holes where scroll saw is to be mounted.
- Drill (3) 7/16 in. diameter holes through workbench.
- Place scroll saw on workbench aligning holes in the base with holes drilled in the workbench.
- Insert all three 3/8 in. bolts and tighten securely with lock washers and hex nuts.

Note: All bolts should be inserted from the top. Install the lock washers and hex nuts from the underside of the bench.

Supporting surface where scroll saw is mounted should be examined carefully after mounting to insure that no movement during use can result. If any tipping or walking is noted, secure workbench or supporting surface before beginning cutting operations.

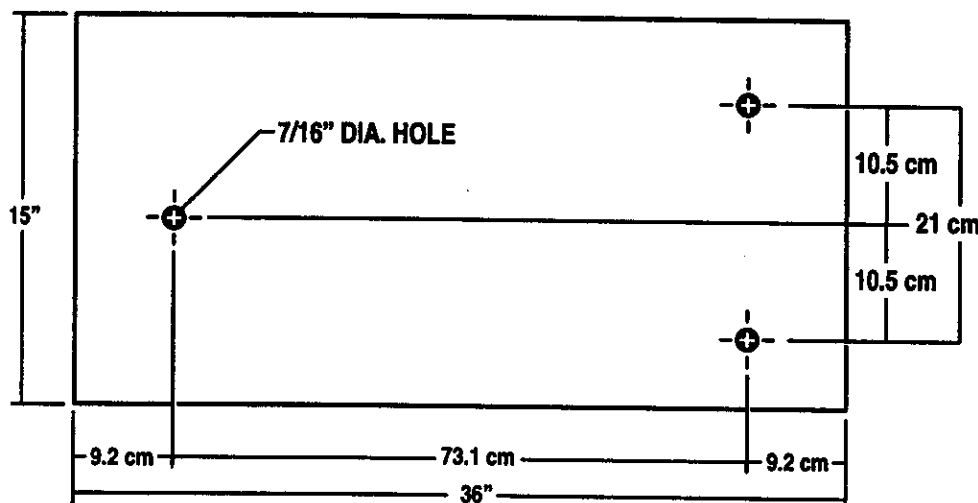

Fig. 5

ASSEMBLY

CLAMPING SCROLL SAW TO WORKBENCH

See Figure 6.

If the scroll saw is to be used in a portable application, we recommend that you fasten it permanently to a mounting board that can easily be clamped to a workbench or other supporting surface. The mounting board should be of sufficient size to avoid tipping of saw while in use.

- Mount saw to board using holes in frame as a template for hole pattern or the diagram in Figure 5. Locate and mark the holes where scroll saw is to be mounted.
- Follow last three steps in previous section called **Mounting Scroll Saw to Workbench**.

Make sure mounting bolts are long enough to go through holes in the saw frame, material being mounted to, lock washers, and hex nuts.

Note: It may be necessary to countersink hex nuts and washers on bottom side of mounting board.

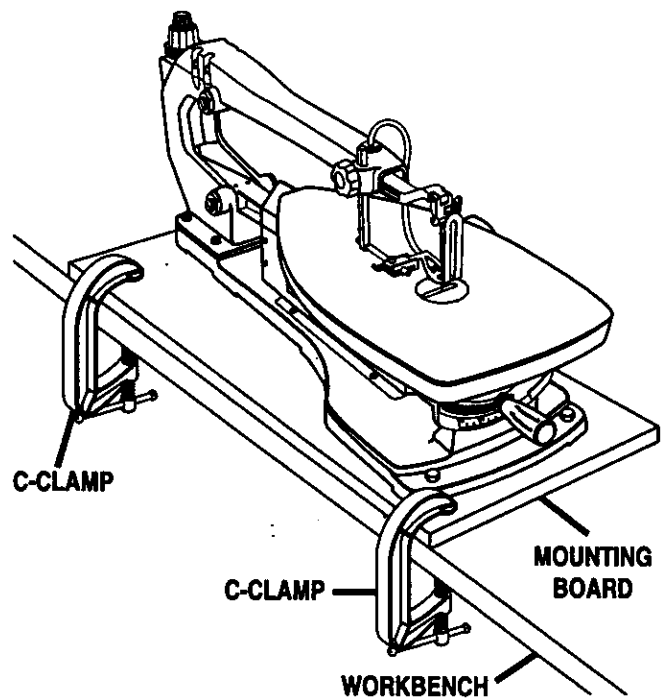

Fig. 6

ADJUSTMENTS

WARNING: To prevent accidental starting that could cause possible serious personal injury, turn off the saw, remove the switch key, and unplug the saw before making any adjustments.

HOLD DOWN FOOT/BLADE GUARD

See Figure 7.

The hold down foot/blade guard should be adjusted so it contacts the top surface of the work being cut. Tighten adjusting knob after adjustment has been made.

- Loosen the hold down foot lock knob.
- Move the hold down foot to the desired position.
- Tighten the hold down foot lock knob.

The tall, front part of the hold down foot acts as a blade guard to prevent accidental contact with the blade.

SAWDUST BLOWER

See Figure 7.

The dust blower is designed and preset to direct air to the most effective point on the cutting line. Be sure hold down foot is properly adjusted to properly secure workpiece and to properly direct air to the cutting surface.

- Insert hose to air diaphragm before starting the saw.

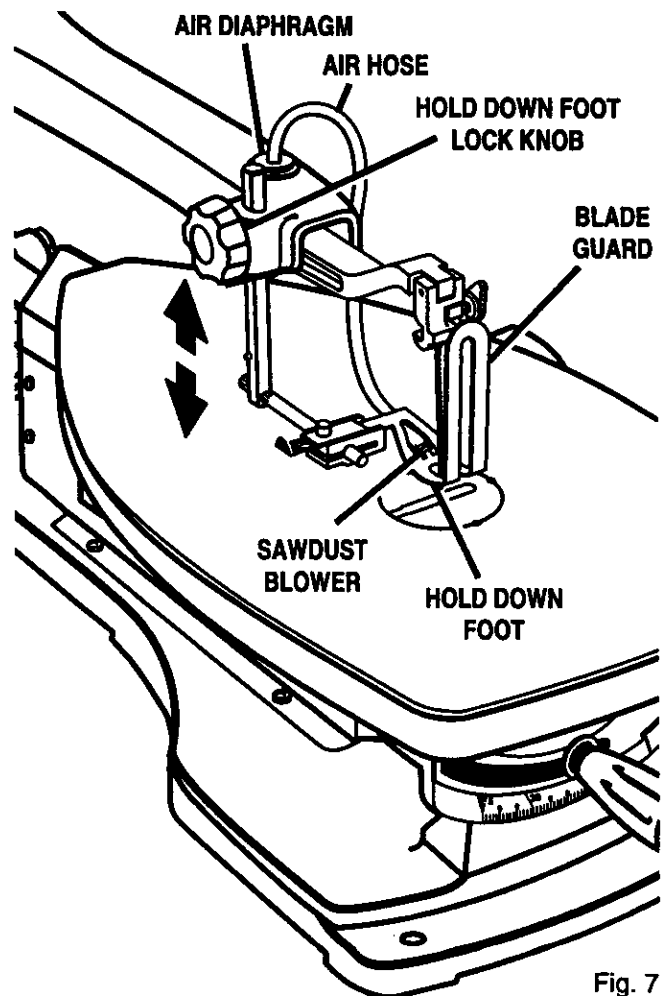

Fig. 7

ADJUSTMENTS

SQUARING TABLE TO THE BLADE

See Figure 8.

- Loosen the hold down foot lock knob and move the hold down rod all the way up. Tighten knob.
- Loosen the table lock knob and move the table until it is approximately perpendicular, or at right angle to the blade.
- Place a small combination square on the table next to the blade to check if the table is 90 degrees to the blade. If adjustment is needed, raise or lower the table until table is approximately 90 degrees to the blade and securely tighten the table lock knob.
- Loosen the screw holding the scale indicator, move indicator to the 0 degree mark and securely tighten screw. Remember, the bevel scale is a convenient guide but should not be relied upon for precision. Make practice cuts on scrap material to determine if your angle settings are correct.
- Adjust the hold down foot to desired position and securely tighten the hold down foot knob.

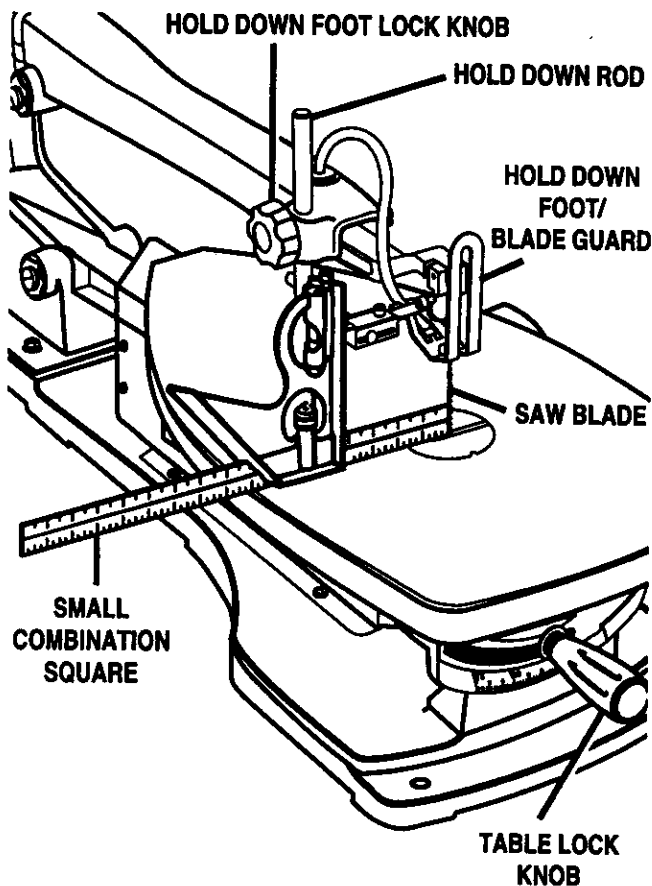

Fig. 8

SETTING THE TABLE FOR HORIZONTAL OR BEVEL CUTTING

See Figures 9 and 10.

A bevel scale is provided under the work table as a convenient guide for setting the approximate table angle for bevel cutting. When greater precision is required, make practice cuts on scrap material and adjust the table as necessary for your requirements. An adjustable zero degree stop is provided to quickly return the table to the zero degree setting.

- Loosen the table lock knob and push down on the right side of the table. If the table stops at 0°, the zero degree stop is properly set. If the table stops somewhere other than zero, then adjust the zero degree stop.

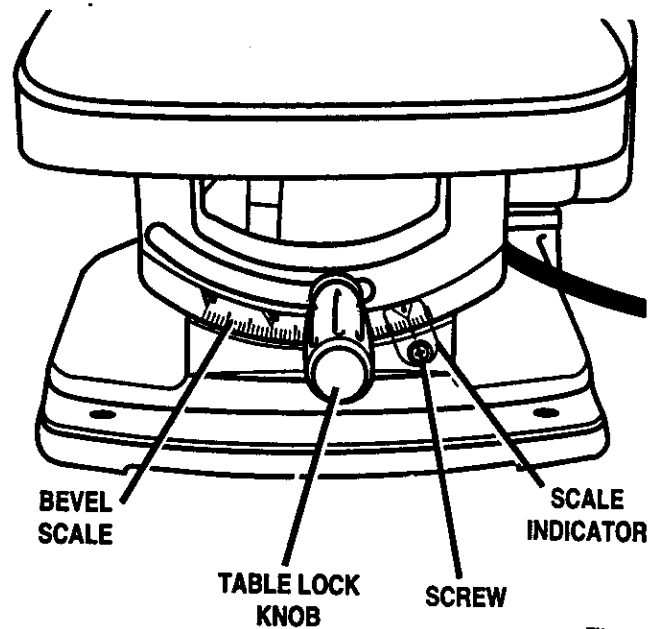

Fig. 9

- To access the zero degree stop, loosen the table lock knob, and tilt the table with the right side all the way up. On top of the motor is a hex nut and hex bolt. See Figure 10. Loosen the hex nut and rotate the hex bolt to raise or lower the bolt as needed to adjust the zero degree stop. Be sure to check to see that the table is square to the blade.

Note: Raise the bolt if you could push the table past the zero on the bevel scale indicator. Lower the bolt if the table will not level out or will not square to the blade.

Now, by returning the table to the zero position, the zero degree stop provides a quick reference to the preset position.

ADJUSTMENTS

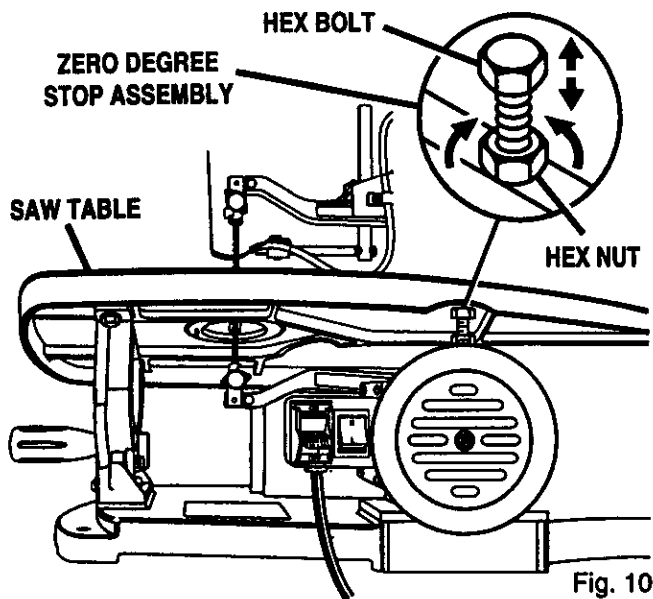

Fig. 10

INSTALLING BLADES

Scroll saw blades wear out quickly and must be replaced frequently for best cutting results. Expect to break some blades while you learn to use and adjust your saw. Blades generally stay sharp for 1/2 hour to 2 hours of cutting, depending on type of material and speed of operation.

Pin End Blades

See Figure 11.

- Turn off the saw, remove the switch key, and unplug the saw from the outlet.

⚠ WARNING: To avoid injury from accidental starting, always turn off the saw, remove the *g* switch key, and unplug the saw before installing, removing or replacing the blade.

- On the top back of the saw, rotate the quick release knob to the left or counterclockwise to loosen blade tension. See Figure 4.
- Remove the throat plate.
- Place blade through the throat plate opening with the teeth of the blade to the front of the saw and pointing down toward the table. Engage the pin into the "V" notch of the lower blade holder.
- Pull up on the blade and push down on the saw arm to engage the upper pin in the "V" notch of the upper blade holder.

Note: If the blade touches the hold down foot on either side then the hold down foot must be adjusted.

- Loosen the foot adjusting setscrew. See Figure 4.
- To center the hold down foot around the saw blade, slide the hold down foot to the side.
- Tighten the foot adjusting knob.

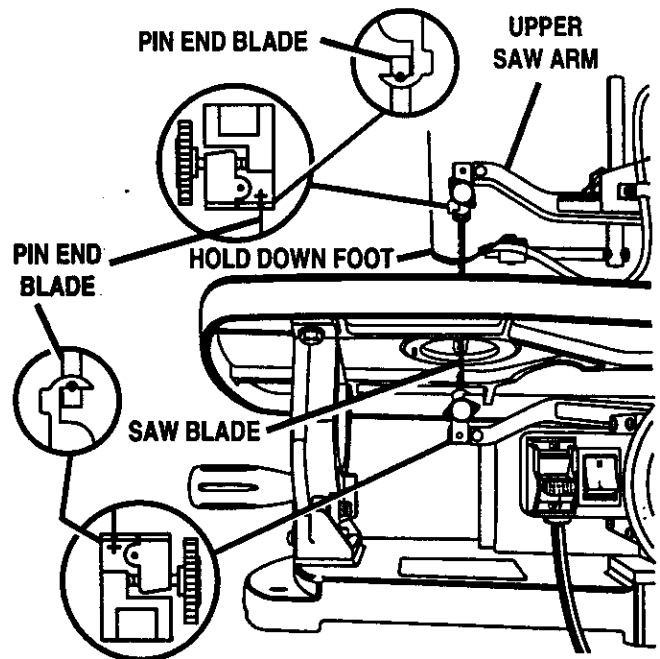

Fig. 11

- To tension the blade, rotate the quick release knob (outer, larger knob) 1/4 turn to the right or clockwise to apply tension to the blade. Fine adjustments of the blade tension may be performed using the tension adjusting knob (inner, smaller knob) at any time, while the blade is under tension or not.

- Replace throat plate.

Plain End Blades

See Figure 12.

- Turn off and unplug the saw from outlet.

⚠ WARNING: To avoid injury from accidental starting, always turn off and unplug the saw before installing, removing, or replacing the blade.

- On the top back of the saw, rotate the quick release knob to the left or counterclockwise to loosen the blade tension. See Figure 4.
- Remove the throat plate.
- Loosen the blade knobs by hand and remove the blade.
- Place new blade through the throat plate opening in the table with the teeth of the blade to the front of the saw and pointing down toward the table. Next, place blade in the lower blade holder into the slot that enlarges as you loosen the blade knob.
- Position blade and securely tighten blade knob.
- Pull up on the blade and down on the upper saw arm to install blade into upper blade holder.

ADJUSTMENTS

Note: If the blade touches the hold down foot on either side then the hold down foot must be adjusted.

- Loosen the foot adjusting knob. *See Figure 13.*
- To center the hold down foot around the saw blade, slide the hold down foot to the side.
- Tighten the foot adjusting knob.
- Position blade and securely tighten blade knob.
- Turn the quick release knob to the right or clockwise to tension the blade.
- Turn the tension adjusting knob to the right, clockwise or to the left, counterclockwise until the blade is in desired tension.
- Replace throat plate.

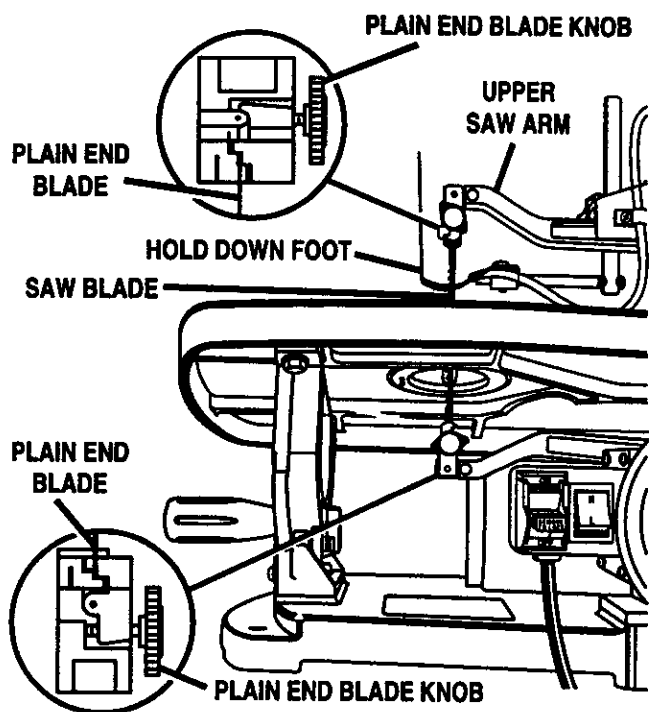

Fig. 12

ADJUSTING BLADE TENSION

See Figures 13 and 14.

- Turn off and unplug the saw.

WARNING: Failure to unplug your saw could result in accidental starting causing possible serious personal injury.

- Tension adjusting knob is on the top of the saw. *See Figure 5.* Rotate the quick release knob (outer, larger knob) 1/4 turn to the left or counterclockwise to release blade tension.

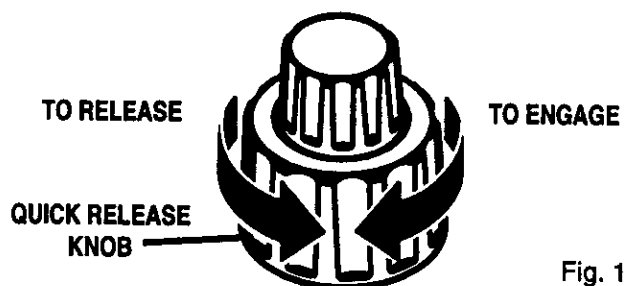

Fig. 13

- Turn tension adjusting knob (upper, smaller knob) to the right or clockwise to increase tension. Turn it to the left or counterclockwise to decrease blade tension.

Note: Adjustments of blade tension can be made at anytime. The quick release knob can be either released or engaged while making adjustments with the tension adjusting knob.

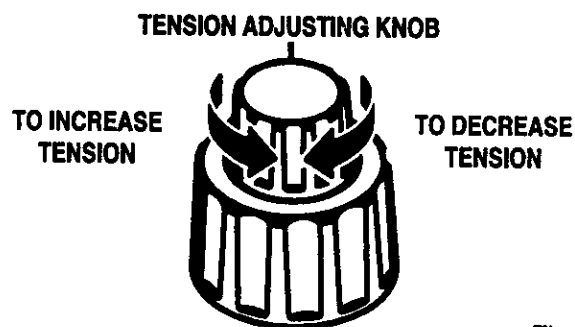

Fig. 14

- Rotate quick release knob to the right or clockwise 1/4 turn to engage tension before using the scroll saw.

Check tension by the sound the blade makes when plucked like a guitar string. This method of adding tension to the blade can be developed with practice and requires knowing your scroll saw.

- Pluck the back straight edge of blade while turning tension adjusting knob. Sound should be a musical note. Sound becomes less flat as tension increases. Sound decreases with too much tension.

Note: Be careful not to over tension the blade. Too much tension may cause blade to break as soon as you start cutting. Too little tension may cause blade to bend or break before teeth wear out.

OPERATION

This scroll saw is designed to cut wood, wood composition products, plastic, and nonferrous metals (aluminum, brass, copper).

WARNING: The operation of any power tool can result in foreign objects being thrown into your eyes, which can result in severe eye damage. To avoid serious personal injury, always wear safety goggles or safety glasses with side shields.

GENERAL OPERATION

Please read and understand the following items concerning your scroll saw before attempting to use the saw.

- There is a learning curve for each person who wants to use this saw. During that period of time, it is expected that some blades will break until you learn how to use and adjust the saw.
- Allow the saw to cut material by guiding the workpiece into the blade as it moves. Do not force the work.
- The blade teeth cut material only on the down stroke.
- You must guide the workpiece into the blade slowly because the teeth of the blade are very small and can only remove material on the down stroke.
- Scroll saw blades wear out and must be replaced frequently for best cutting results. Scroll saw blades generally stay sharp for 1/2 hour to 2 hours of cutting, depending on type of material and speed of operation.
- To get accurate cuts, be prepared to compensate for the blade's tendency to follow the wood grain as you are cutting wood.
- In cutting wood, best results are achieved when cutting wood less than one inch thick.
- When cutting wood thicker than one inch, the user must guide the workpiece very slowly into the blade and take extra care not to bend or twist the blade while cutting.
- When choosing a blade to use with your scroll saw, consider the following carefully:
 - Very fine, narrow blades should be used to scroll cut in thin material 1/4 in. thick or less.
 - Most blade packages state the size or thickness and type of material which that blade is intended to cut. Package should also state the radius, or size of curve, which can be cut with that blade.
 - Wider blades cannot cut curves as tight or small as thinner blades.

- Blades wear faster:
 - When cutting plywood and other laminates.
 - When cutting material thicker than 3/4 in.
 - When cutting hardwood.
 - When side pressure is applied to the blade.

SWITCH

See Figure 14.

Your scroll saw has an easy access power On/Off switch. To lock the switch in the Off position, remove the switch key from the switch. Place the key in a location that is inaccessible to children and others not qualified to use the tool.

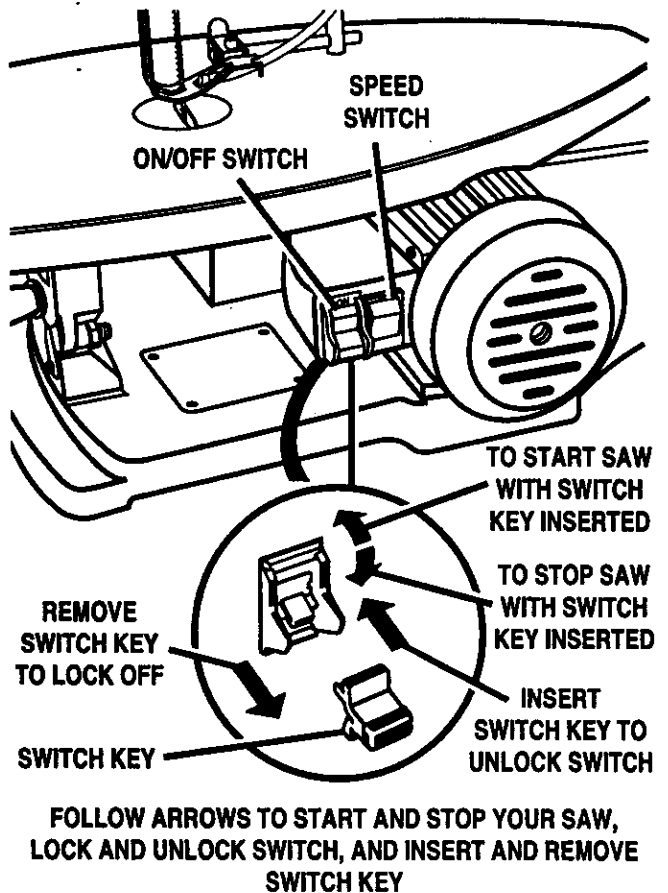

Fig. 14

SPEED SWITCH

See Figure 14.

The speed switch, beside the ON/OFF switch, allows you to choose a high speed of approximately 1725 SPM (Strokes Per Minute) or a low speed of approximately 825 SPM.

- Use the high speed when cutting hard woods, a large radius, or rough cut out.
- Use the low speed when cutting soft woods, a small radius, or intricate details. Slow down when precision cutting is needed.

OPERATION

INTERIOR SCROLL CUTTING

See Figure 15.

- One of the features of a scroll saw is that it can be used to make scroll cuts on the interior of a board without breaking or cutting through the edge or perimeter of the board.
- ⚠ **WARNING:** To avoid possible serious injury from accidental starting, always turn the switch OFF, remove the switch key, and remove plug from power source outlet before removing or replacing the blade.
- To make interior cuts in a board, remove the scroll saw blade as explained in the **Installing Blades** section on page 14.
- Drill a 1/4 in. hole in the board to be used to make interior cuts.
- Place the board on the saw table with the hole in the board over the access hole in the table.
- Install blade through hole in board then adjust the hold down foot and the blade tension. See pages 14 and 15.
- When finished making the interior scroll cuts, simply remove the blade from the blade holders as described in the **Installing Blades** section, and remove the board from the table.

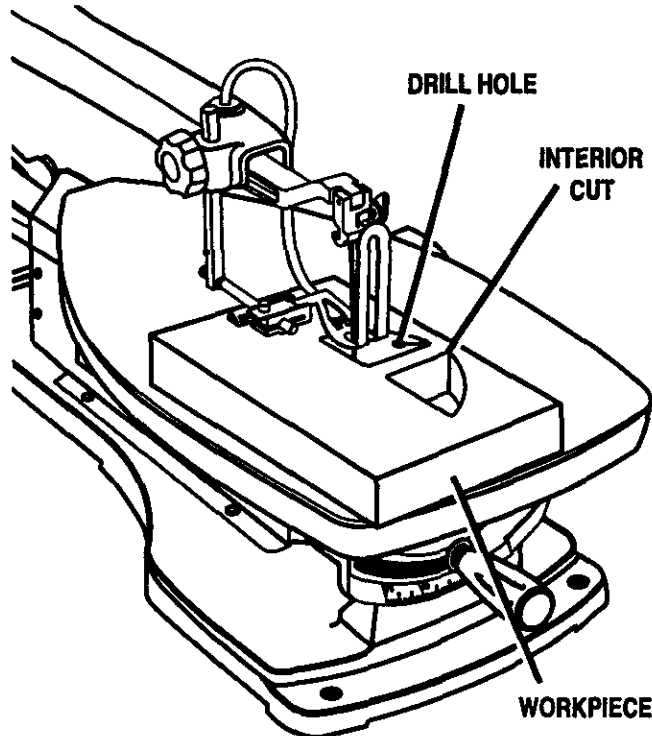

Fig. 15

STACK CUTTING

See Figure 16.

After becoming well acquainted with your saw through practice and experience, you may wish to try stack cutting. Stack cutting may be used when several identical shapes need to be cut. Several pieces of wood may be stacked on top and secured to each other before cutting. The wood pieces may be joined together by placing double sided tape between each piece or by wrapping masking tape around the corners or ends of the stacked wood. You must attach the stacked pieces of wood to each other so they will move on the table as a single piece of material.

- ⚠ **WARNING:** To avoid possible, serious personal injury, do not cut more than one loose piece of material at a time.

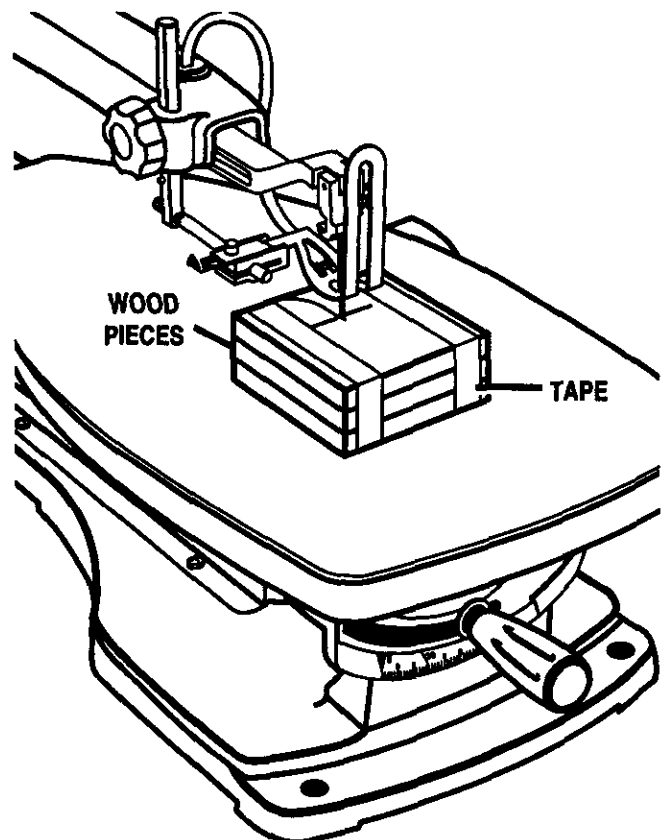

Fig. 16

- ⚠ **CAUTION:** If the blade is jammed due to aggressive cutting, and the motor stalls, turn off the power switch. Remove wood. Turn saw back on to resume cutting.

OPERATION

CHOICE OF BLADE AND SPEED

The scroll saw accepts a wide variety of blade widths and thicknesses for cutting wood and other fibrous materials. Your saw uses 5 inch long blades of either the pin end or the plain end style. The blade width and thickness and the number of teeth per inch to use are determined by the type of material and the size of the radius being cut. A full selection of scroll saw blades are available through Sears Retail Stores.

Note: As a general rule, always select narrow blades for intricate curve cutting, and wide blades for straight and large curve cutting.

Teeth/inch	Width	Thickness	Speed	Material Cut
10 - 14	.110 - .045 in.	.020 - .015 in.	Hi	Popular size for cutting hard and soft woods 3/16 in. up to 2 in. Plastics, paper, felt, bone, etc.
15 - 20	.110 - .032 in.	.020 in.	Hi/Lo	Wood, plastics, extremely thin cuts on materials 1/4 in. to 1/2 in. thick.
18 - 46	.040 - .015 in.	.020 - .012 in.	Lo	For tight radius work in thin materials 3/32 in. to 1/8 in. wood, veneer, bone, fiber, ivory, plastic, etc.

BEFORE EACH USE:

- **INSPECT YOUR SAW.** Disconnect the saw. To avoid injury from accidental starting, turn the switch OFF and unplug the saw before changing the setup or removing covers, guards, or blade.
- **INSPECT YOUR WORKPIECE.** Make sure there are no nails or foreign objects in the workpiece to be cut.
- **USE EXTRA CAUTION WITH LARGE, VERY SMALL, OR AWKWARD WORKPIECES.**
 - Never use this tool to cut pieces too small to hold by hand.
 - Always use extra supports (tables, saw horses, blocks, etc.) for any workpiece large enough to tip when not held down to the table top.
 - Never use another person as a substitute for a table extension, or as additional support for a workpiece or to help feed, support, or pull the workpiece.
 - When cutting an irregularly shaped workpiece, plan your work so it will not pinch the blade. A piece of molding, for example, must lay flat or be held by a fixture or jig that will not let it twist, rock, or slip while being cut.
 - Properly support round material such as dowel rods. They have a tendency to roll during a cut, causing the blade to "bite." To avoid this, always use a "v" block.
- Clear everything except the workpiece and related support devices off the table before plugging into power and turning the saw on.
- **PLAN THE WAY YOU WILL HOLD THE WORKPIECE FROM START TO FINISH.** Do not hand hold pieces so small that your fingers will go under the work hold-down.
- **BEFORE FREEING ANY JAMMED MATERIAL:**
 - Turn switch OFF.
 - Wait for all moving parts to stop.
 - Unplug the saw.
- **WHEN BACKING OUT OF THE WORKPIECE, THE BLADE MAY BIND IN THE KERF (CUT). THIS IS USUALLY CAUSED BY SAWDUST CLOGGING UP THE KERF. IF THIS HAPPENS:**
 - Turn switch OFF.
 - Wait for all moving parts to stop.
 - Unplug the saw.
 - Remove the blade from the blade holders.
 - Remove the workpiece with blade from the table.
 - Remove blade from workpiece.



WARNING: Before removing loose pieces from the table, turn saw off and wait for all moving parts to stop to avoid serious personal injury.

MAINTENANCE

- WARNING:** When servicing, use only identical Craftsman replacement parts. Use of any other part may create a hazard or cause product damage.
- WARNING:** To prevent accidental starting that could cause possible serious personal injury, turn off and unplug the saw before maintaining or lubricating your scroll saw.

GENERAL MAINTENANCE

- Keep your Scroll Saw clean.
- After cleaning the table top initially, apply a thin coat of automobile type (paste) wax to the table top so the wood slides easily while cutting.

ARM BEARINGS

See *Figure 17*.

Lubricate the arm bearings after every 50 hours of use or whenever there is a squeak coming from the bearings.

- Carefully place the saw on its side as shown in *Figure 17*.
- Squirt a few drops of SAE20 oil in the small hole in the middle of the slot. Lubricate both upper arm and lower arm bearings. Let oil soak in overnight, remaining in this position.

- WARNING:** If the power cord is worn, cut, or damaged in any way, have it replaced immediately by a qualified service technician at a Sears store to avoid risk of personal injury.

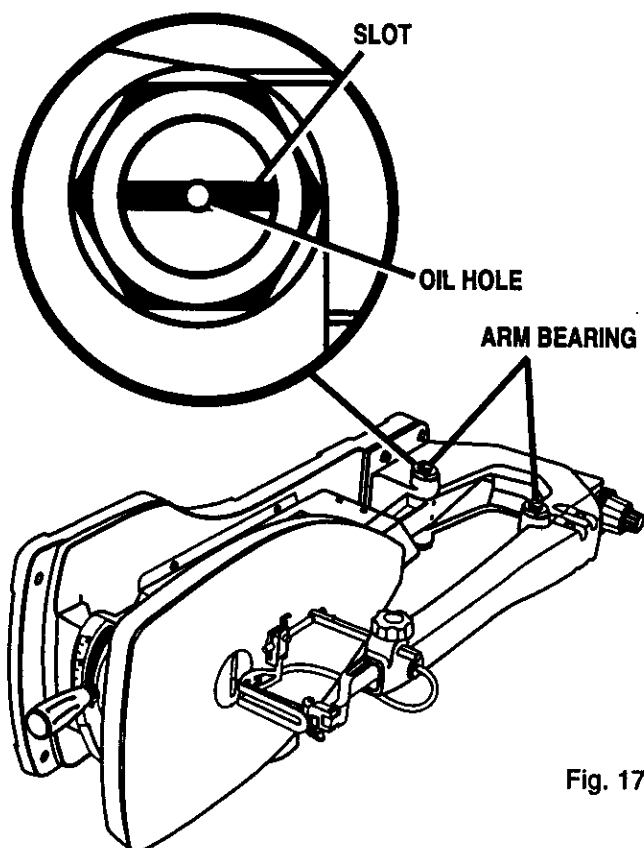

Fig. 17

TROUBLESHOOTING

⚠ WARNING: For your own safety, turn switch **OFF** and remove plug from power outlet before adjusting or aligning your scroll saw.

PROBLEM	CAUSE	SOLUTION
Motor will not run.	<ol style="list-style-type: none"> 1. Problem with ON-OFF switch, power cord, or outlet. 2. Motor Defective. 3. Motor stalled due to blade jammed in wood. 	<ol style="list-style-type: none"> 1. Have worn parts replaced before using Scroll Saw again. Have the proper outlet installed by a qualified electrician. 2. Do not attempt any repair. Have repaired by a qualified service technician at a Sears store or repair center. 3. Turn off the power switch. Remove wood. Turn saw back on to resume cutting.
Blades breaking.	<ol style="list-style-type: none"> 1. Too much tension. 2. Feeding too quickly. 3. Wrong blade. 4. Blade twisting in wood. 	<ol style="list-style-type: none"> 1. Adjust tension. 2. Reduce feed rate. 3. Narrow blades for cutting thin wood or tight corners and turns, wide blades for thicker wood or wide turns. 4. Reduce side pressure on blade, check blade tension.
Vibration (there is always some vibration when the saw is running).	<ol style="list-style-type: none"> 1. Improper mounting of saw. 2. Mounting surface. 3. Loose table or table resting against motor. 4. Loose motor mounting. 	<ol style="list-style-type: none"> 1. Check mounting. 2. Check mounting in manual. 3. Tighten table lock knob. 4. Tighten mounting screws.
Blade runout (blade not properly aligned with arm motion).	<ol style="list-style-type: none"> 1. Blade holders out of line. 	<ol style="list-style-type: none"> 1. Realign blade.

CRAFTSMAN SCROLL SAW - MODEL NO. 315.216230

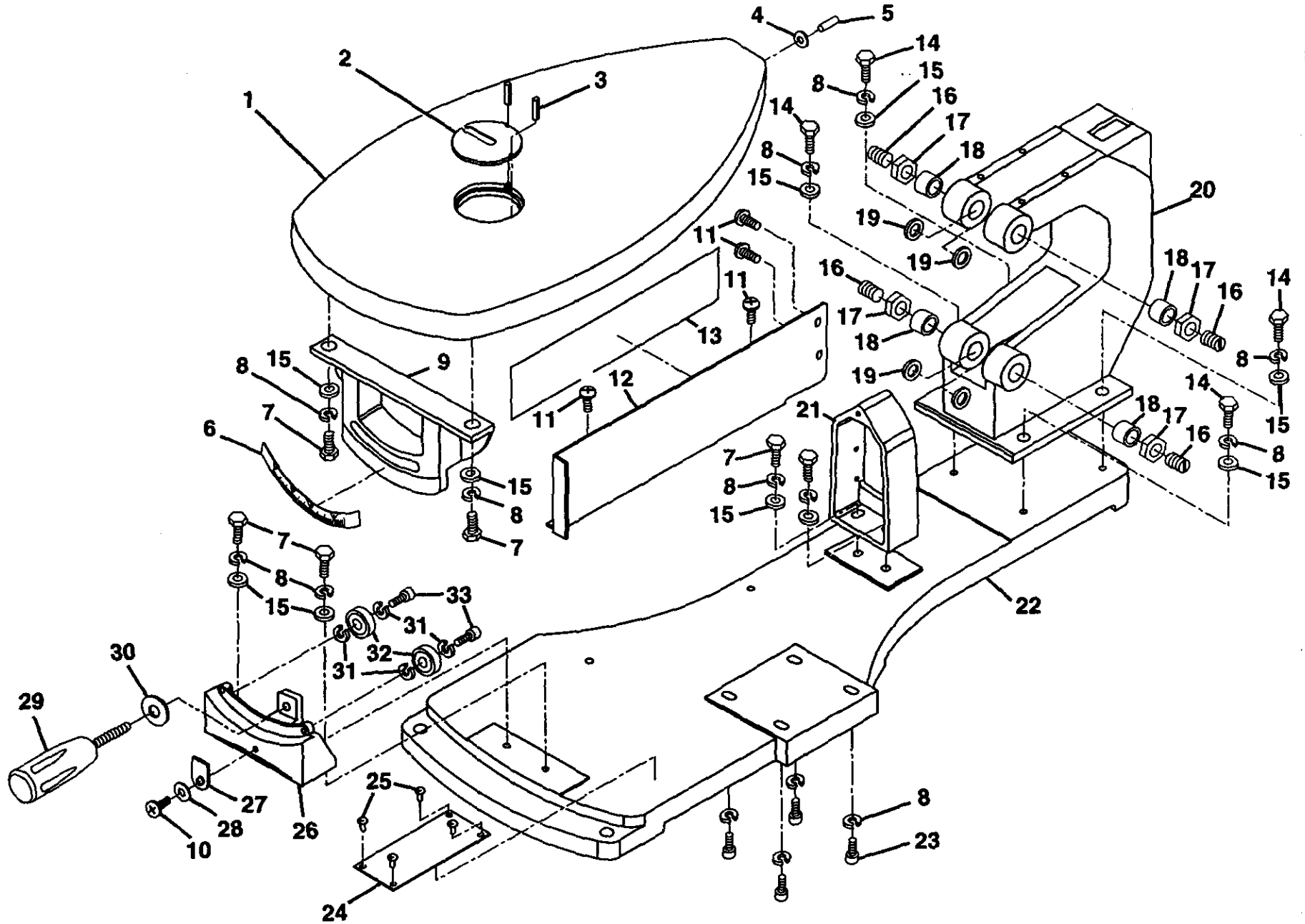

FIGURE A

PARTS LIST FOR FIGURE A

Key No.	Part Number	Description	Quan.	Key No.	Part Number	Description	Quan.
1	977115-001	Table	1	18	977123-001	Shaft Bushing.....	4
2	977159-001	Table Insert	1	19	977160-001	Thrust Washer.....	4
3	977166-001	Spring Pin (M3 x 10)	2	20	977146-001	Body	1
4	STD851005 **	Washer (M5)	1	21	977161-001	Rear Table Support	1
5	977150-001	Table Pivot Pin	1	22	977107-001	Base	1
6	977131-001	Label (Angle).....	1	23	977172-001 *	Cap Screw (M8 x 20)	4
7	STD523107 **	Screw (Hex 5/16-18 x 3/4 in.)	6	24	977125-001	Warning/Data Label	1
8	STD551131 **	Spring Washer (5/16 in.)	14	25	980752-001	Rivet	2
9	977129-001	Table Angle Support.....	1	26	977114-001	Base Angle Support	1
10	STD511003 *	Screw (10-24x 3/8 in. Rd. Hd.).....	1	27	977157-001	Indicator	1
11	980751-001	Screw	4	28	STD551010 **	Flat Washer	1
12	977128-001	Cover (Side).....	1	29	977116-001	Knob.....	1
13	977135-001	Logo Label	1	30	STD551031 **	Flat Washer	1
14	STD523110 *	Screw (5/16-18 x 1 in. Hex Hd.).....	4	31	STD551025 **	Spring Washer (1/4 in.)	4
15	STD551031	Washer (Flat 5/16 in.).....	10	32	977158-001	Ball Bearing (607zz).....	2
16	977144-001 *	Arbor Adjustment Screw	4	33	977165-001	Cap Screw (1/4-20 x 5/8 in.)	2
17	977145-001 *	Lock Nut.....	4				

23

* Standard Hardware Item — May Be Purchased Locally

** Available From Division 98 - Source 980.00

*** Available at your nearest Sears Retail Store.

CRAFTSMAN SCROLL SAW – MODEL NO. 315.216230

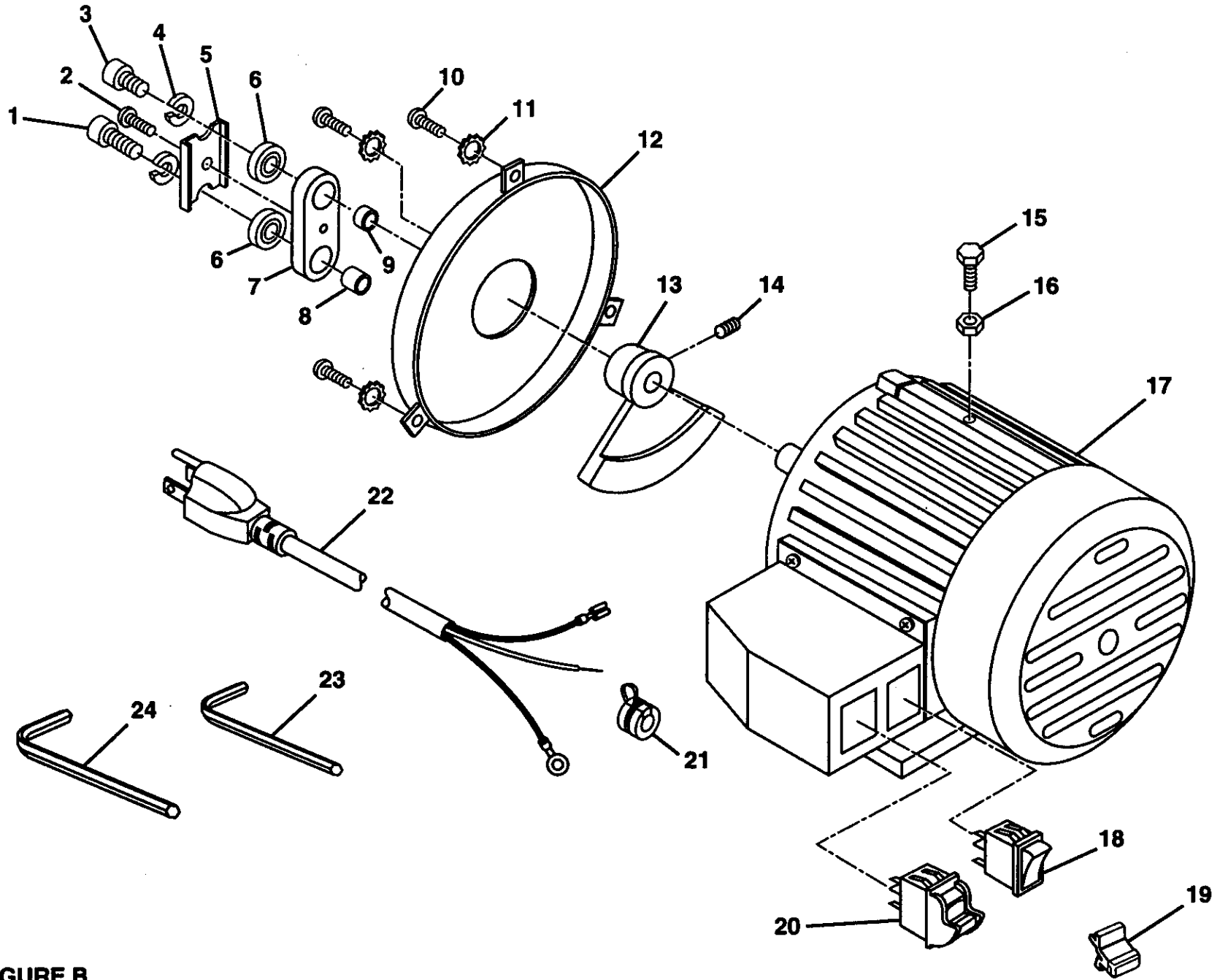

24

FIGURE B

PARTS LIST FOR FIGURE B

Key No.	Part Number	Description	Quan.	Key No.	Part Number	Description	Quan.
1	977164-001	* Cap Screw (3/16-24 x 1")	1	13	977111-001	Balance Weight	1
2	977163-001	* Screw (M3 x 8)	1	14	STD502502	* Set Screw (1/4-20 x 1/4 in.)	1
3	980753-001	Cap Screw (M5 x 8 x 20)	1	15	STD522510	* Screw (1/4-20 x 1 in. Hex. Hd.)	1
4	STD852005	* Lock Washer (M5)	2	16	STD541025	* Hex Nut (1/4-20)	1
5	977108-001	Connecting Rod Cover	1	17	977137-001	Motor (Includes Key Nos. 18, 20, 22)	1
6	977126-001	Ball Bearing	2	18	977112-001	Switch (2-speed)	1
7	977109-001	Connecting Rod	1	19	989039-002	Switch Key	1
8	977127-001	Lower Spacer	1	20	612444-001	Switch (On/Off/with key)	1
9	977136-001	Upper Spacer	1			(Includes Key No. 19)	
10	977155-001	* Screw (M 4 x 10 Rd. Hd.)	3	21	977156-001	Strain Relief Bushing	1
11	980754-001	Star Washer	3	22	977148-001	Power Cord	1
12	977110-001	Guard	1	23	977176-001	Hex Key (M2)	1
				24	977177-001	Hex Key (M4)	1

25

* Standard Hardware Item — May Be Purchased Locally

** Available From Division 98 - Source 980.00

*** Available at your nearest Sears Retail Store.

CRAFTSMAN SCROLL SAW - MODEL NO. 315.216230

26

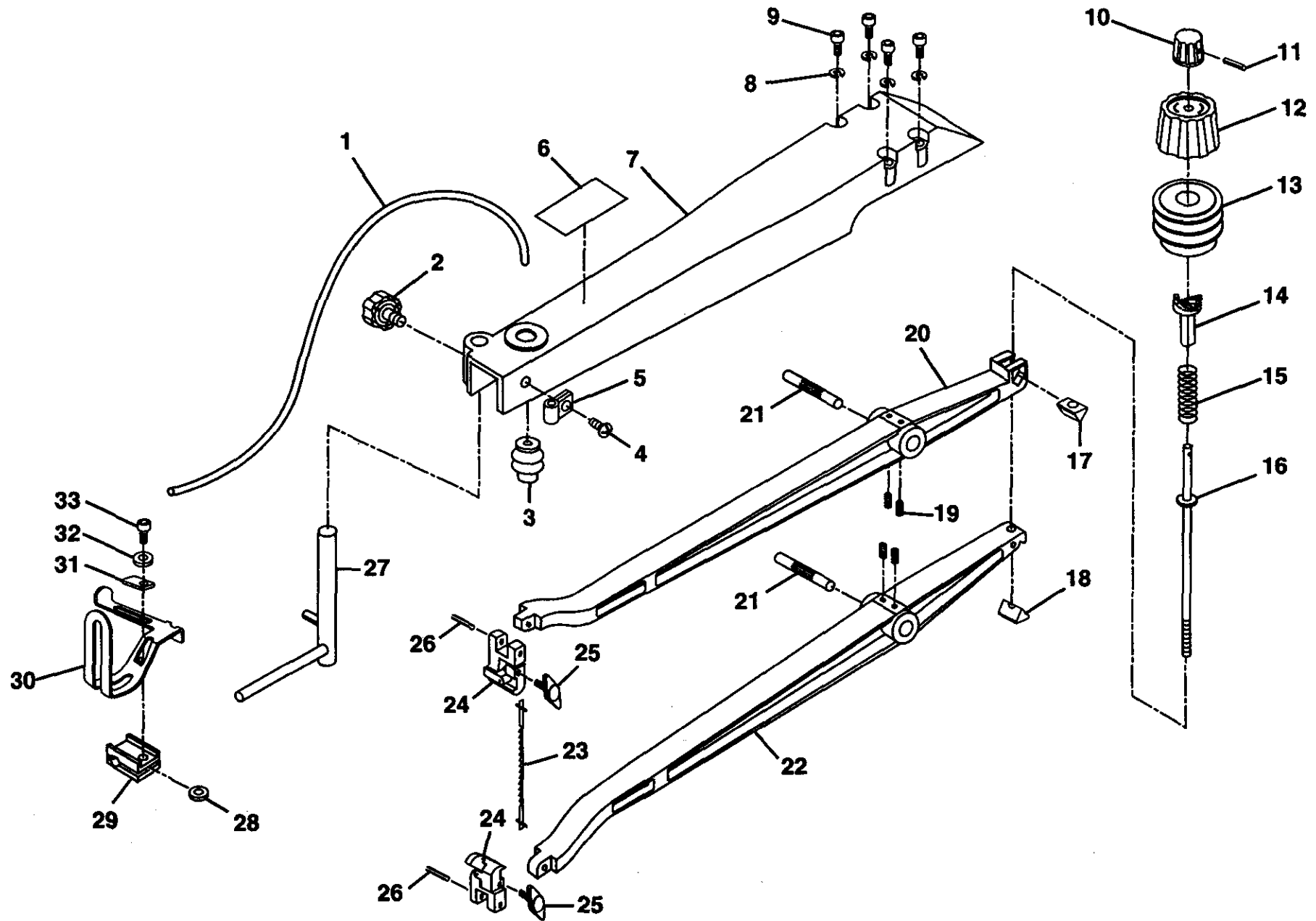

FIGURE C

PARTS LIST FOR FIGURE C

Key No.	Part Number	Description	Quan.	Key No.	Part Number	Description	Quan.
1	977119-001	Tube	1	18	977124-001	Rocker (Lower)	1
2	977133-001	Knob	1	19	STD502505 *	Set Screw (1/4-20 x 1/2 in.)	4
3	977134-001	Bellows	1	20	977139-001	Upper Arm	1
4	STD511003 *	Screw (10-24x 3/8 in. Rd. Hd.)	1	21	977141-001	Shaft	2
5	977162-001	Clamp	1	22	977132-001	Lower Arm	1
6	977147-001	Warning Label (Top)	1	23	***	Saw Blade	2
7	977140-001	Arm Cover	1	24	977154-001	Blade Holder	2
8	STD551025 **	Spring Washer (1/4 in.)	4	25	977175-001	Blade Lock Knob	2
9	977170-001 *	Cap Screw (1/4-20 x 1 in.)	4	26	977169-001	Spring Pin (M5 x 22)	2
10	977182-001	Tension Knob	1	27	977138-002	Support Rod Assembly	1
11	977171-001	Spring Pin (M3.5 x 24)	1	28	980755-001	Flat Washer	1
12	977181-001	Quick Release Knob	1	29	977152-001	Foot Support	1
13	977121-001	Rubber Boot	1	30	977117-001	Hold Down Foot	1
14	977183-001	Cam	1	31	977151-001	Upper Clamp Spacer	1
15	977120-001	Spring	1	32	STD852005 **	Flat Washer (M5)	1
16	977143-001	Blade Tension Rod	1	33	977167-001 *	Cap Screw (M5 x 16)	1
17	977142-001	Rocker (Upper)	1		972000-527	Owner's Manual	

27

* Standard Hardware Item — May Be Purchased Locally

** Available From Division 98 - Source 980.00

*** Available at your nearest Sears Retail Store.

For in-home major brand repair service:

Call 24 hours a day, 7 days a week

1-800-4-MY-HOMESM (1-800-469-4663)

Para pedir servicio de reparación a domicilio – 1-800-676-5811

In Canada for all your service and parts needs call – **1-800-665-4455**
Au Canada pour tout le service ou les pièces

For the repair or replacement parts you need:

Call 6 am – 11 pm CST, 7 days a week

PartsDirectSM

1-800-366-PART (1-800-366-7278)

Para ordenar piezas con entrega a domicilio – 1-800-659-7084

For the location of a Sears Parts and Repair Center in your area:

Call 24 hours a day, 7 days a week

1-800-488-1222

**For information on purchasing a Sears Maintenance Agreement
or to inquire about an existing Agreement:**

Call 9 am – 5 pm, Monday – Saturday

1-800-827-6655



The Service Side of Sears